



US006398929B1

(12) **United States Patent**  
**Chiang et al.**

(10) **Patent No.:** **US 6,398,929 B1**  
(45) **Date of Patent:** **Jun. 4, 2002**

(54) **PLASMA REACTOR AND SHIELDS GENERATING SELF-IONIZED PLASMA FOR SPUTTERING**

*Primary Examiner*—Rodney G. McDonald  
(74) *Attorney, Agent, or Firm*—Law Offices of Charles Guenzer

(75) **Inventors:** **Tony P. Chiang**, San Jose; **Yu D. Cong**, Sunnyvale; **Peijun Ding**, San Jose; **Jianming Fu**, San Jose; **Howard H. Tang**, San Jose; **Anish Tolia**, San Jose, all of CA (US)

(57) **ABSTRACT**

A DC magnetron sputter reactor for sputtering copper, its method of use, and shields and other parts promoting self-ionized plasma (SIP) sputtering, preferably at pressures below 5 milli Torr, preferably below 1 milli Torr. Also, a method of coating copper into a narrow and deep via or trench using SIP for a first copper layer. SIP is promoted by a small magnetron having poles of unequal magnetic strength and a high power applied to the target during sputtering. The target power for a 200 mm wafer is preferably at least 10 kW; more preferably, at least 18 kW; and most preferably, at least 24 kW. Hole filling with SIP is improved by long-throw sputtering in which the target-to-substrate spacing is at least 50% of substrate diameter, more preferably at least 80%, most preferably at least 140%. The SIP copper layer can act as a seed and nucleation layer for hole filling with conventional sputtering (PVD) or with electrochemical plating (ECP). For very high aspect-ratio holes, a copper seed layer is deposited by chemical vapor deposition (CVD) over the SIP copper nucleation layer, and PVD or ECP completes the hole filling. The copper seed layer may be deposited by a combination of SIP and high-density plasma sputtering. For very narrow holes, the CVD copper layer may fill the hole. Preferably, the plasma is ignited in a cool process in which low power is applied to the target in the presence of a higher pressure of argon working gas. After ignition, the pressure is reduced, and target power is ramped up to a relatively high operational level to sputter deposit the film.

(73) **Assignee:** **Applied Materials, Inc.**, Santa Clara, CA (US)

(\*) **Notice:** Subject to any disclaimer, the term of this patent is extended or adjusted under 35 U.S.C. 154(b) by 0 days.

(21) **Appl. No.:** **09/414,614**

(22) **Filed:** **Oct. 8, 1999**

(51) **Int. Cl.<sup>7</sup>** ..... **C23C 14/34**

(52) **U.S. Cl.** ..... **204/298.11**

(58) **Field of Search** ..... 204/298.11

(56) **References Cited**

**U.S. PATENT DOCUMENTS**

- 5,658,442 A \* 8/1997 Van Gogh et al. .... 204/298.12
- 5,690,795 A \* 11/1997 Rosenstein et al. .... 204/192.1
- 5,736,021 A 4/1998 Ding et al. .... 204/298.11
- 5,879,523 A 3/1999 Wang et al. .... 204/298.11

**FOREIGN PATENT DOCUMENTS**

EP 0 878 843 11/1998

\* cited by examiner

**22 Claims, 6 Drawing Sheets**

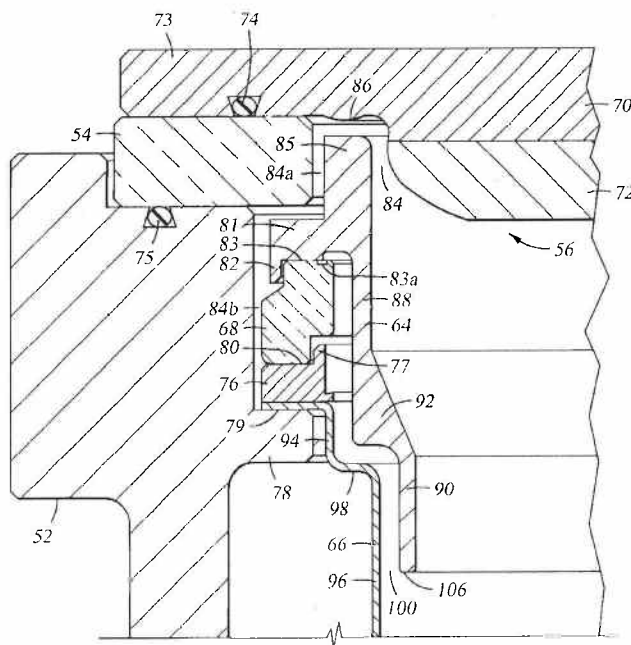

*Fig. 1*  
(PRIOR ART)

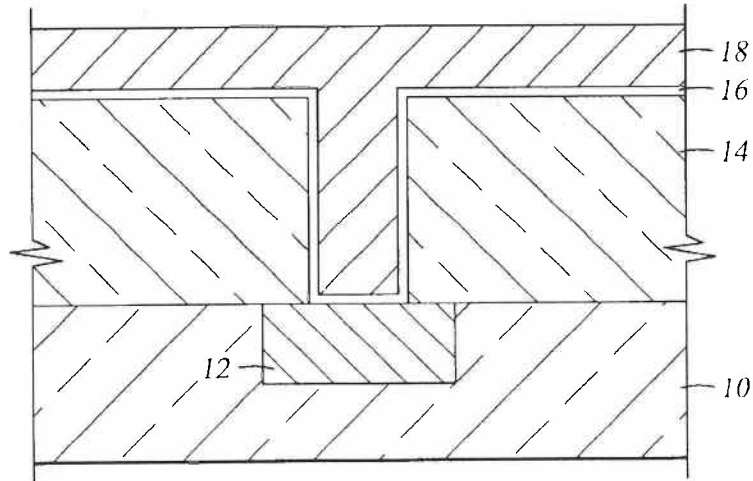

*Fig. 2*  
(PRIOR ART)

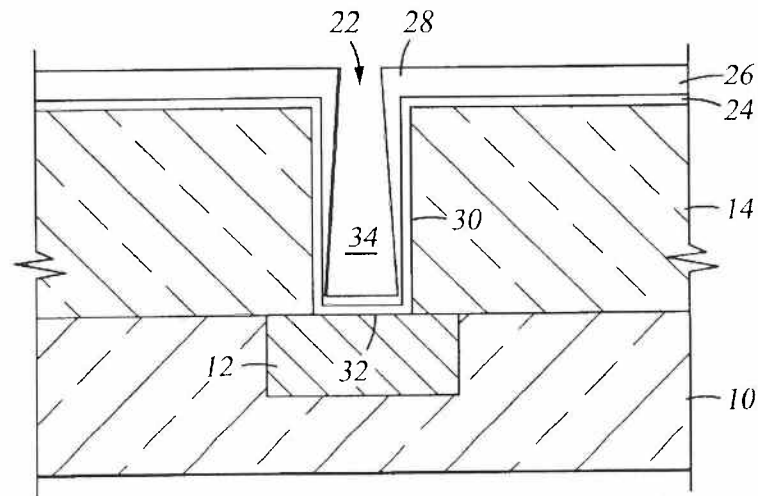

*Fig. 3*  
(PRIOR ART)

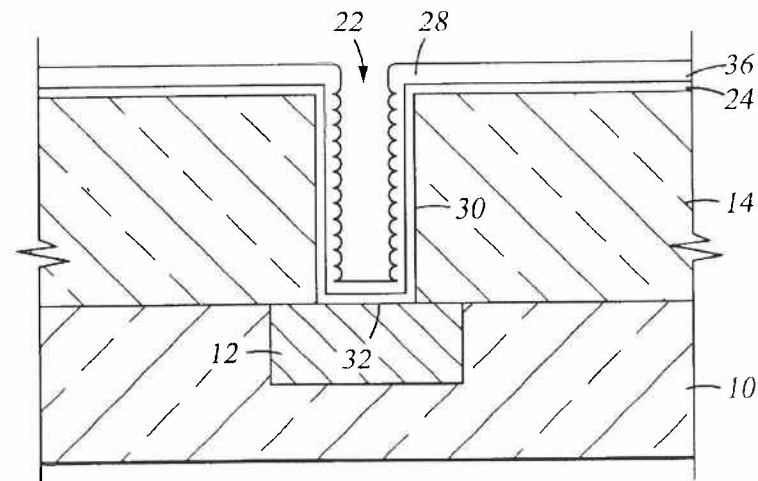

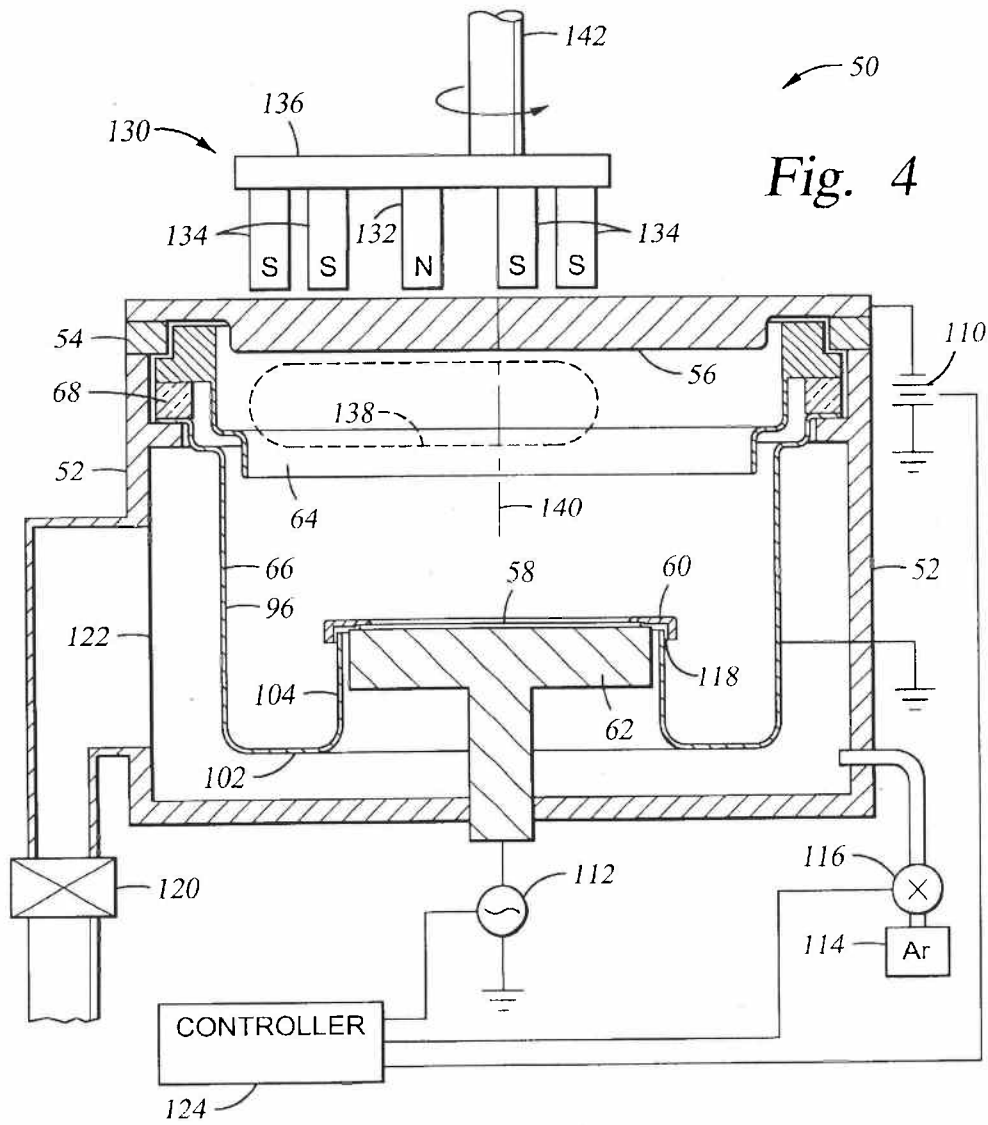

Fig. 4

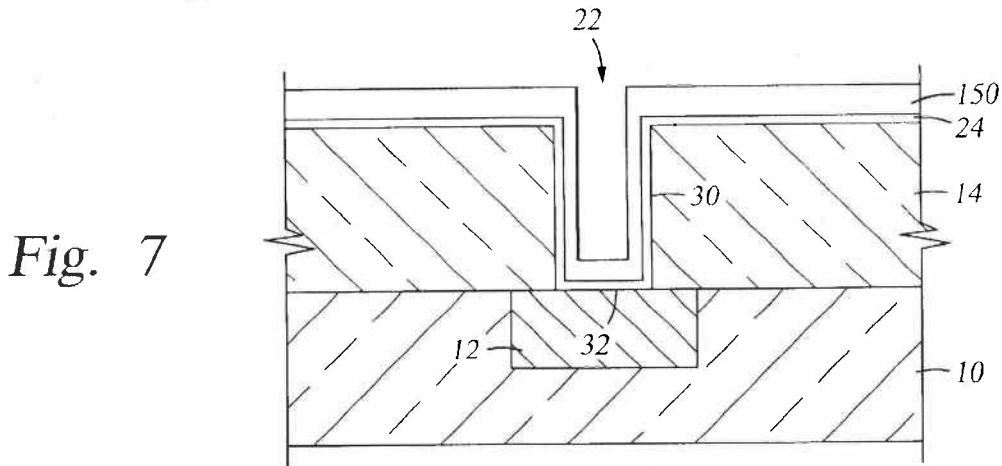

Fig. 7

Fig. 5

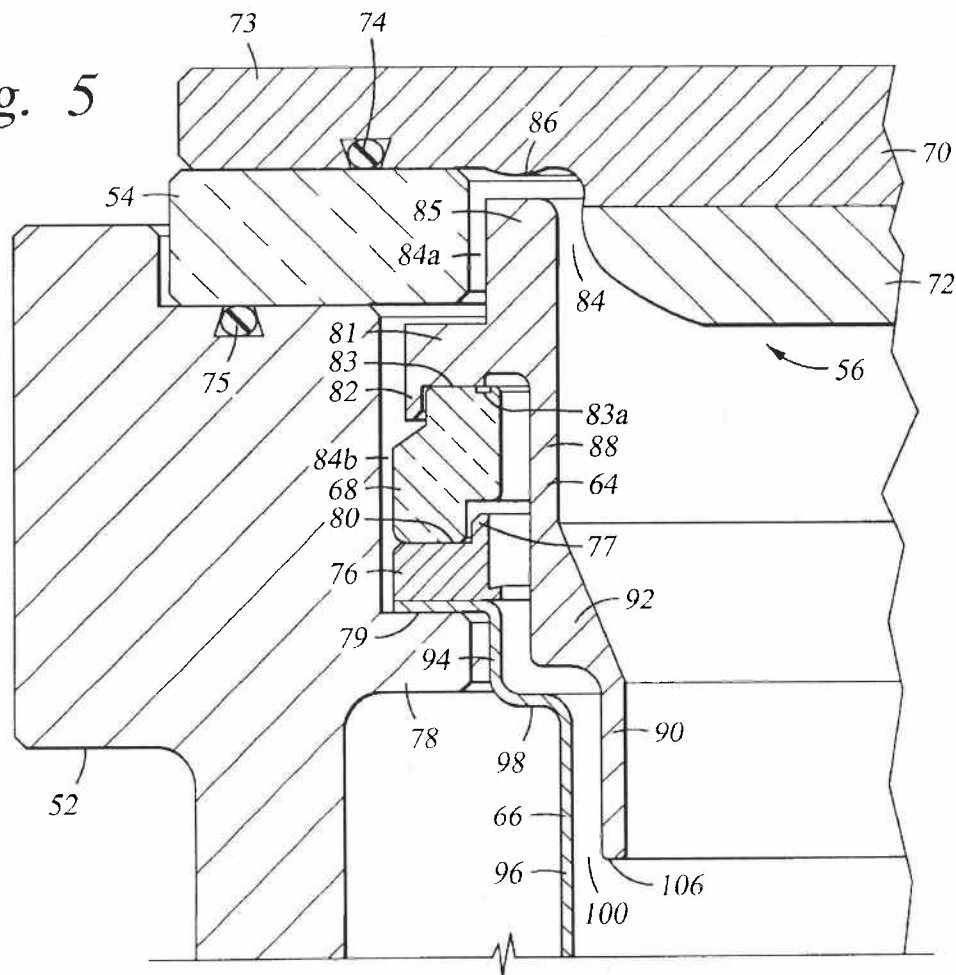
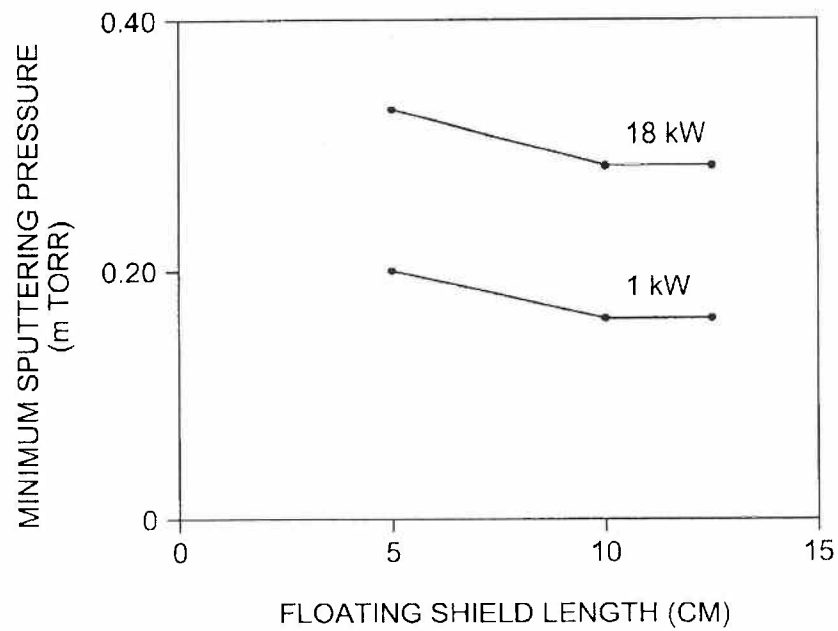

Fig. 6



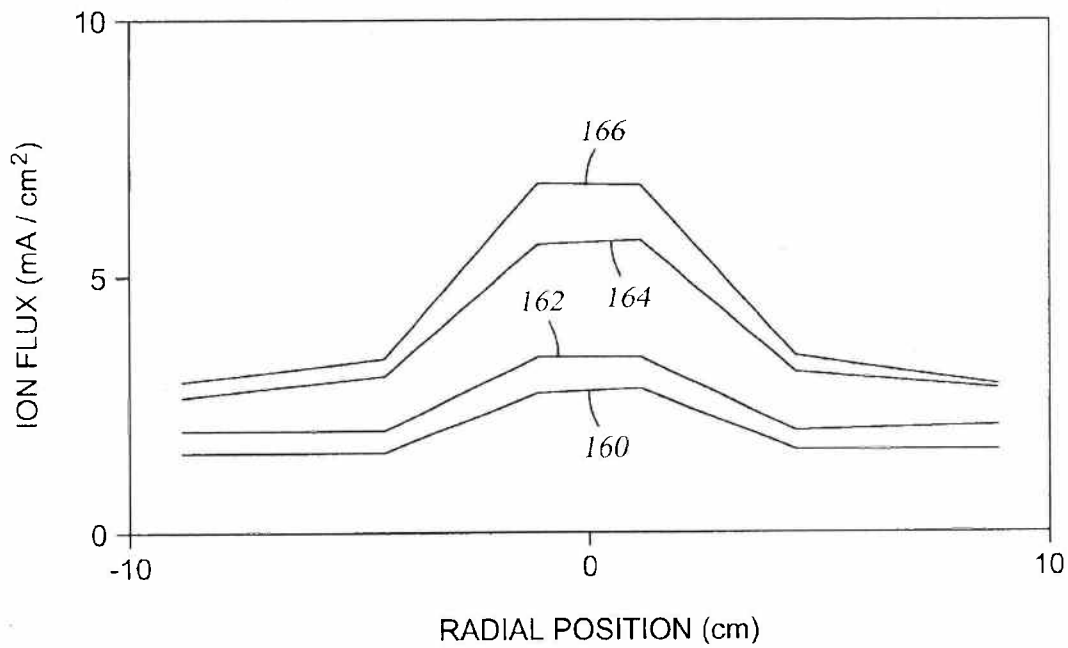

Fig. 8

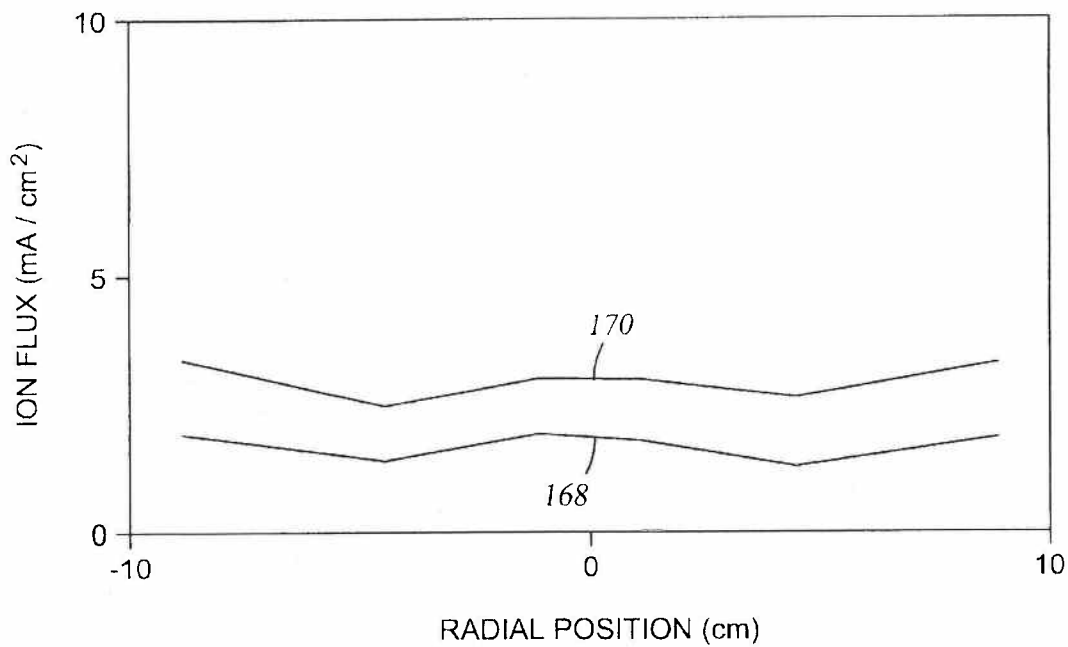

Fig. 9

# Explore Litigation Insights

Docket Alarm provides insights to develop a more informed litigation strategy and the peace of mind of knowing you're on top of things.

## Real-Time Litigation Alerts



Keep your litigation team up-to-date with **real-time alerts** and advanced team management tools built for the enterprise, all while greatly reducing PACER spend.

Our comprehensive service means we can handle Federal, State, and Administrative courts across the country.

## Advanced Docket Research



With over 230 million records, Docket Alarm's cloud-native docket research platform finds what other services can't. Coverage includes Federal, State, plus PTAB, TTAB, ITC and NLRB decisions, all in one place.

Identify arguments that have been successful in the past with full text, pinpoint searching. Link to case law cited within any court document via Fastcase.

## Analytics At Your Fingertips



Learn what happened the last time a particular judge, opposing counsel or company faced cases similar to yours.

Advanced out-of-the-box PTAB and TTAB analytics are always at your fingertips.

## API

Docket Alarm offers a powerful API (application programming interface) to developers that want to integrate case filings into their apps.

## LAW FIRMS

Build custom dashboards for your attorneys and clients with live data direct from the court.

Automate many repetitive legal tasks like conflict checks, document management, and marketing.

## FINANCIAL INSTITUTIONS

Litigation and bankruptcy checks for companies and debtors.

## E-DISCOVERY AND LEGAL VENDORS

Sync your system to PACER to automate legal marketing.