

Fundamentals of Automatic Control

Robert C. Weyrick
Community and Technical College
The University of Akron

McGraw-Hill Book Company

New York	Montreal
St. Louis	New Delhi
Dallas	Panama
San Francisco	Paris
Düsseldorf	São Paulo
Johannesburg	Singapore
Kuala Lumpur	Sydney
London	Tokyo
Mexico	Toronto

TJ
213
W43

134771

ess Cataloging in Publication Data

C
of automatic control.

ontrol. I. Title.

74-10896

-1

ALS OF AUTOMATIC CONTROL

975 by McGraw-Hill, Inc. All rights reserved.

United States of America. No part of this publication

uced, stored in a retrieval system, or transmitted, in

any means, electronic, mechanical, photocopying, recording,

without the prior written permission of the publisher.

0 K P K P 7 8 3 2 1 0 9 8 7 6 5

To my mother

his book were Alan W. Lowe and
g, the designer was Tracy A. Glasner,
on was supervised by Valerie Klima and Laurence Charnow.
dallion by York Graphic Services, Inc.
nd bound by Kingsport Press, Inc.

DOCKET
ALARM

Find authenticated court documents without watermarks at docketalarm.com.

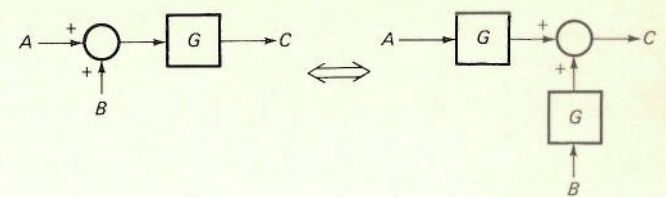

Figure 1-10 Moving summing point around a block

a system diagram to effect simplification is termed *block-diagram algebra* since it is analogous to simplifying algebraic equations. However, reducing a block diagram has the advantage of providing a better understanding of the interrelationships of the various elements in the system as compared to simplifying the system equations.

The combining of cascaded blocks into a single block, as described in Sec. 1-5, is obviously one step toward simplification. As another possibility, it is sometimes useful to move a summing point around a block as indicated in Fig. 1-10. Note that the inputs A and B are introduced through blocks incorporating the function G around which the summing point was moved. Applying the distributive property of algebra, we see that $C = (A + B)G = AG + BG$. Thus the two diagrams are equivalent.

Table 1-1 gives a number of transformations useful in simplifying block diagrams. These transformations can be verified by showing that the outputs from the two equivalent diagrams are the same. Note that the original and equivalent identities can be used interchangeably.

1-7 CLOSED-LOOP TRANSFER FUNCTION

Since certain functions and types of variables are commonly associated with feedback control systems, a generalized block diagram may be formulated and the associated closed-loop transfer function derived. Some standardization of the symbols and terminology relating to feedback control systems has been achieved and is used in this case.

Figure 1-11 is a general block diagram of a closed-loop control system. It is important that the terms used in this diagram be clearly understood.

System Variables

The *desired value V* is an external signal applied to the system to command a specific output from the process. The desired value is sometimes called the *system command* or *set point*.

Elements of automatic control

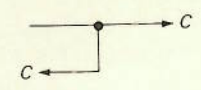

Figure 1-8 Takeoff-point representation

es being combined at a summing point must be in the same ample, two voltages may be combined but a voltage and nnot be brought together. Any number of variables may ming point.

point is used when the output of a block is applied to two ks. A takeoff point is simply represented by a dot as shown

ite the block-diagram representation of a system, let us ne the oven-temperature control described in the preceding system is shown in block-diagram form in Fig. 1-9. In this diagram the various blocks may be identified with elements a. In addition the units associated with the transfer function k are shown in parentheses.

diagram tends to clarify the physical understanding of the provides a convenient basis for system analysis. We shall t block diagrams are useful in pointing out the similarity parently unrelated systems. It should be emphasized that onnecting one block with another represent the flow of rmation within the system. The main sources of energy for eed not be included in the block diagram.

1-6 SIMPLIFICATION OF BLOCK DIAGRAMS

diagram that is initially drawn for a system may contain ber of blocks and signal paths and be more complicated rable. In such cases a simplification may be performed to block diagram to a form with fewer blocks. Rearranging

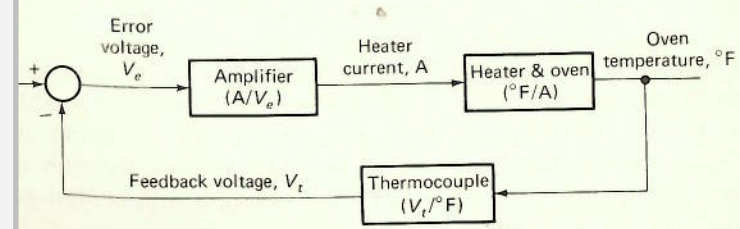

Figure 1-9 Block diagram of oven-temperature control

TABLE 1-1 BLOCK-DIAGRAM IDENTITIES

Configuration	Original	Equivalent
Series blocks		
Parallel blocks		
Summing point block		
Summing point block		
Summing point block		
Summing point block		
Summing point block		
Closed-loop system		

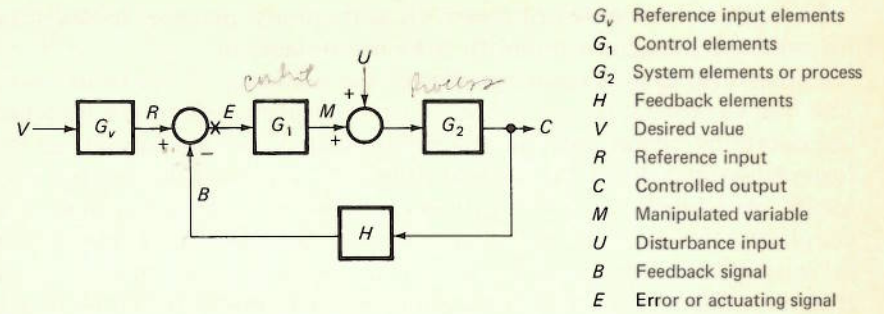

Figure 1-11 General block diagram of control system

The reference input R is derived from the desired value and is a signal external to the control loop. It serves as the reference of comparison for the feedback signal.

The controlled output C is the process quantity being controlled. The manipulated variable M is the control signal which the control elements apply to the process.

The feedback signal B is a signal which is a function of the controlled output and which is summed with the reference input.

The error or actuating signal E is the algebraic difference between the reference input and feedback signals and provides the signal applied to the control elements.

The disturbance input U is an unwanted input signal to the system that tends to cause the controlled output to differ from the value commanded by the reference input. Disturbance inputs are due to changes in the load on the system. For example, a change in the ambient temperature surrounding the oven described in Sec. 1-3 is a disturbance since it changes the heat input required by the oven. Obviously the response of the system to a disturbance input should be minimal.

System Elements

The reference input elements G_v convert the desired value to a reference input signal.

The control elements G_1 , sometimes called the controller, are the components that act on the error signal and generate a control signal to the process.

The feedback elements H are the components required to measure or sense the value of the controlled output and convert it to a usable feedback signal.