



US 20050004523A1

(19) **United States**

(12) **Patent Application Publication** (10) **Pub. No.: US 2005/0004523 A1**

Osborne et al. (43) **Pub. Date: Jan. 6, 2005**

(54) **SMALL GAUGE NEEDLE
CATHETERIZATION APPARATUS**

Publication Classification

(75) Inventors: **Thomas A. Osborne**, Bloomington, IN (US); **David G. Burton**, Bloomington, IN (US)

(51) **Int. Cl.⁷** **A61M 5/178**

(52) **U.S. Cl.** **604/164.01**

Correspondence Address:
**INDIANAPOLIS OFFICE 27879
BRINKS HOFER GILSON & LIONE
ONE INDIANA SQUARE, SUITE 1600
INDIANAPOLIS, IN 46204-2033 (US)**

(57) **ABSTRACT**

An apparatus for percutaneous catheterization. The apparatus comprises a catheter, and an inner cannula received within the lumen of the catheter. The inner cannula has a distal portion that tapers toward the distal end, and is sized to extend through the distal opening of the catheter to provide a generally smooth diametrical transition between the distal end of the catheter and the distal open end of the inner cannula. A stiffening cannula is sized to be received in the lumen of the inner catheter, and has an inner diameter sized to receive a wire guide therethrough. The stiffening cannula as a distal section of greater flexibility than the flexibility of a proximal section for providing kink resistance to the apparatus.

(73) Assignee: **Cook Incorporated**

(21) Appl. No.: **10/879,409**

(22) Filed: **Jun. 29, 2004**

Related U.S. Application Data

(60) Provisional application No. 60/484,414, filed on Jul. 2, 2003.

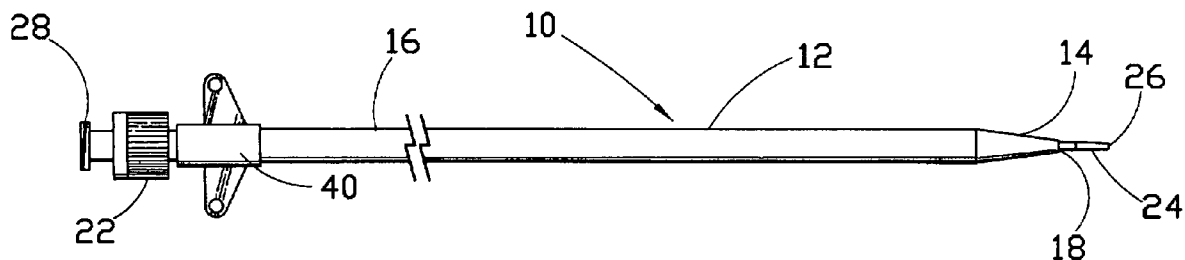

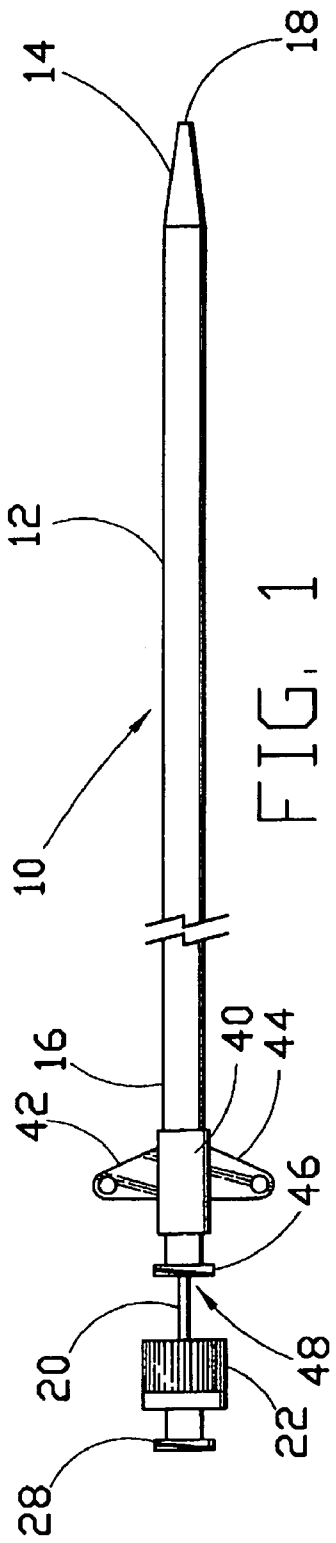

FIG. 1

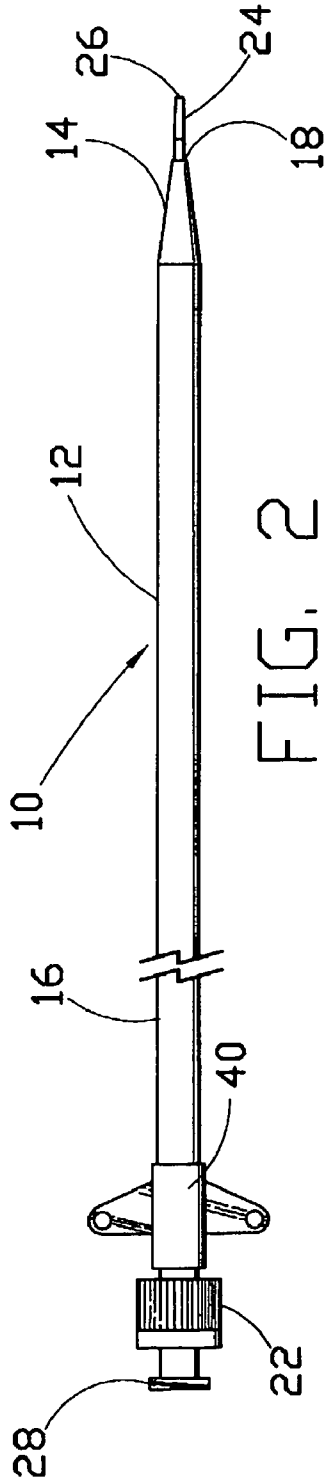

FIG. 2

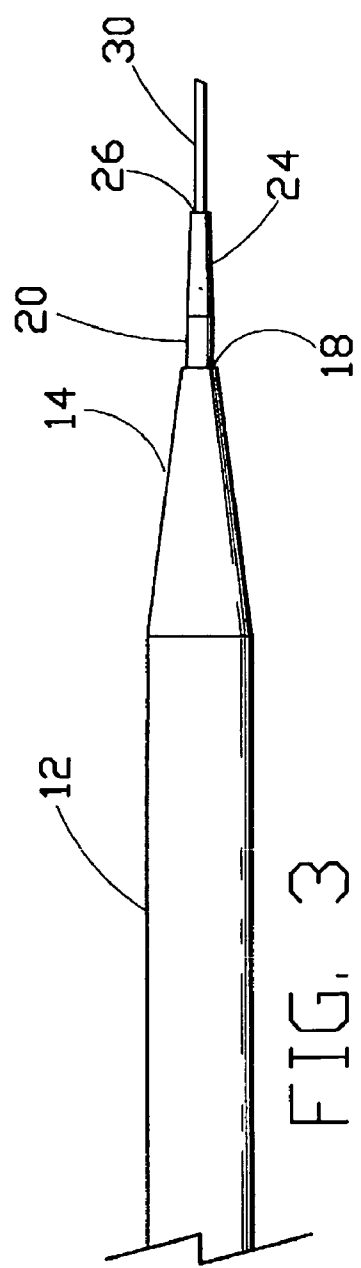
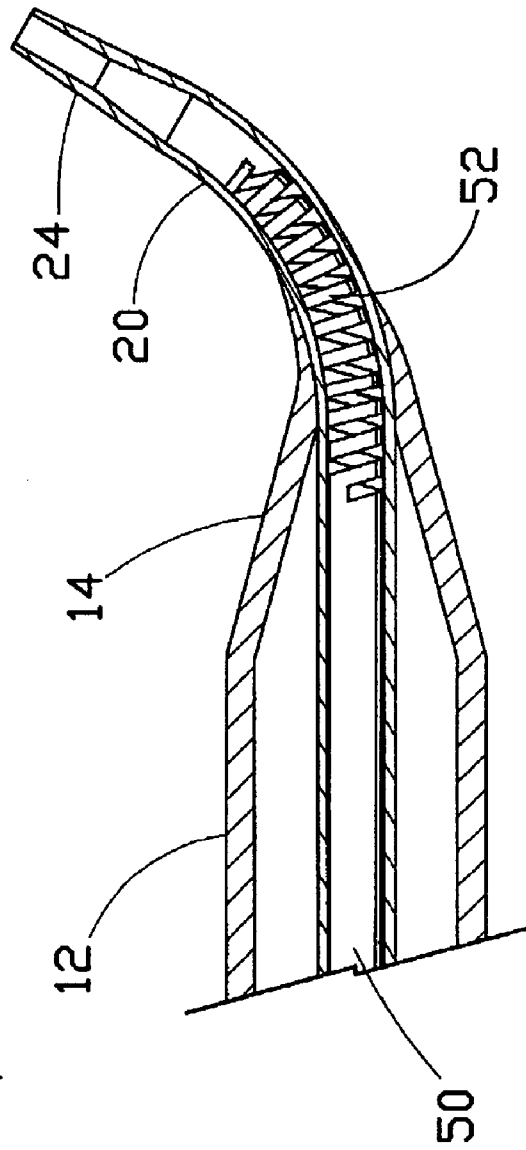
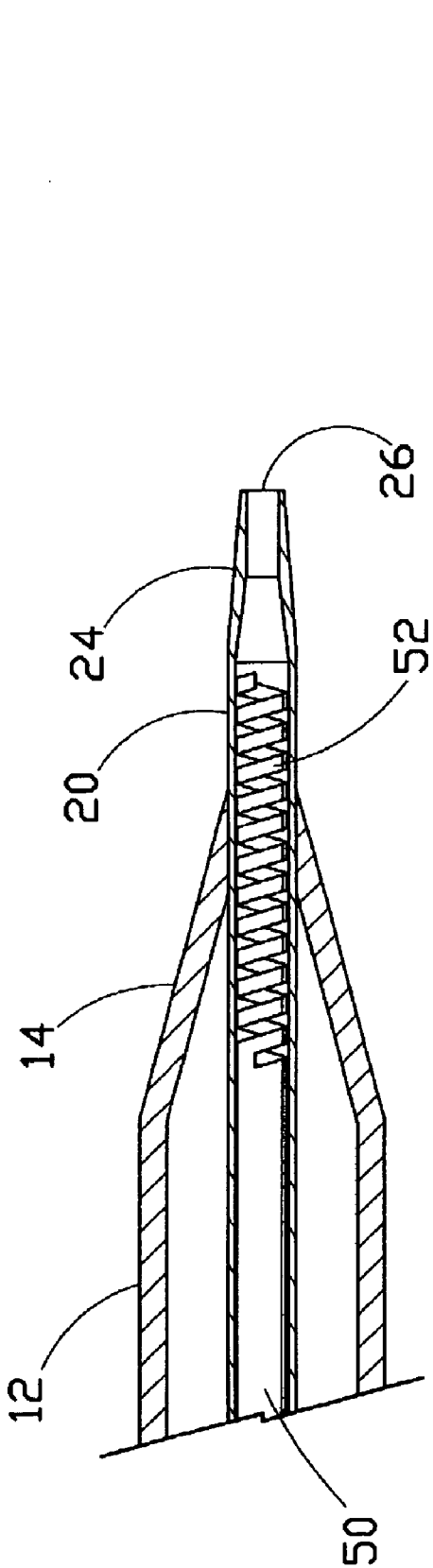
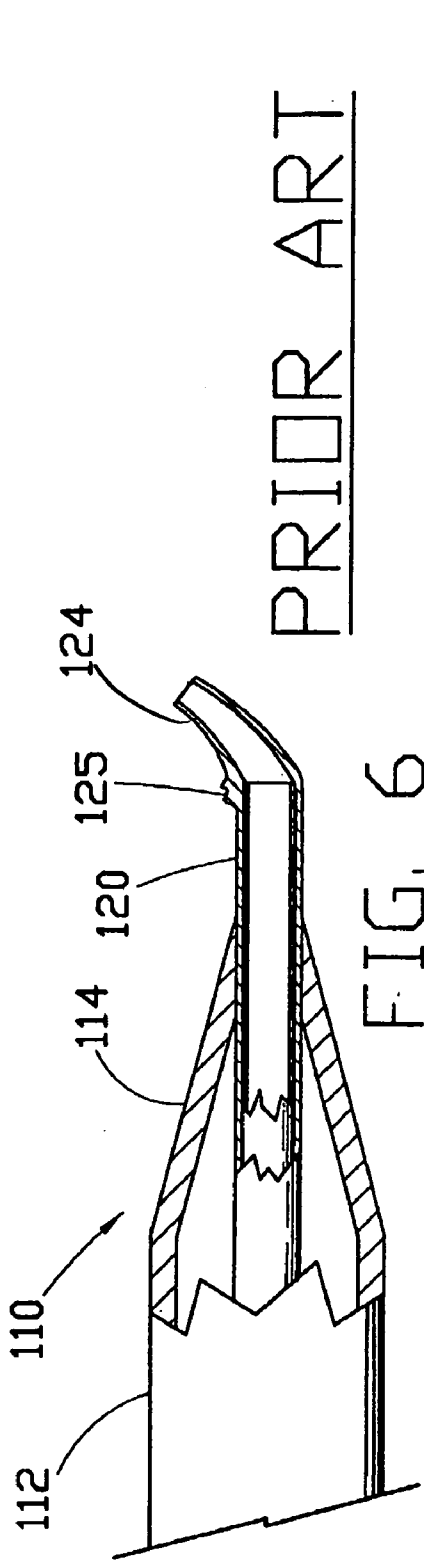
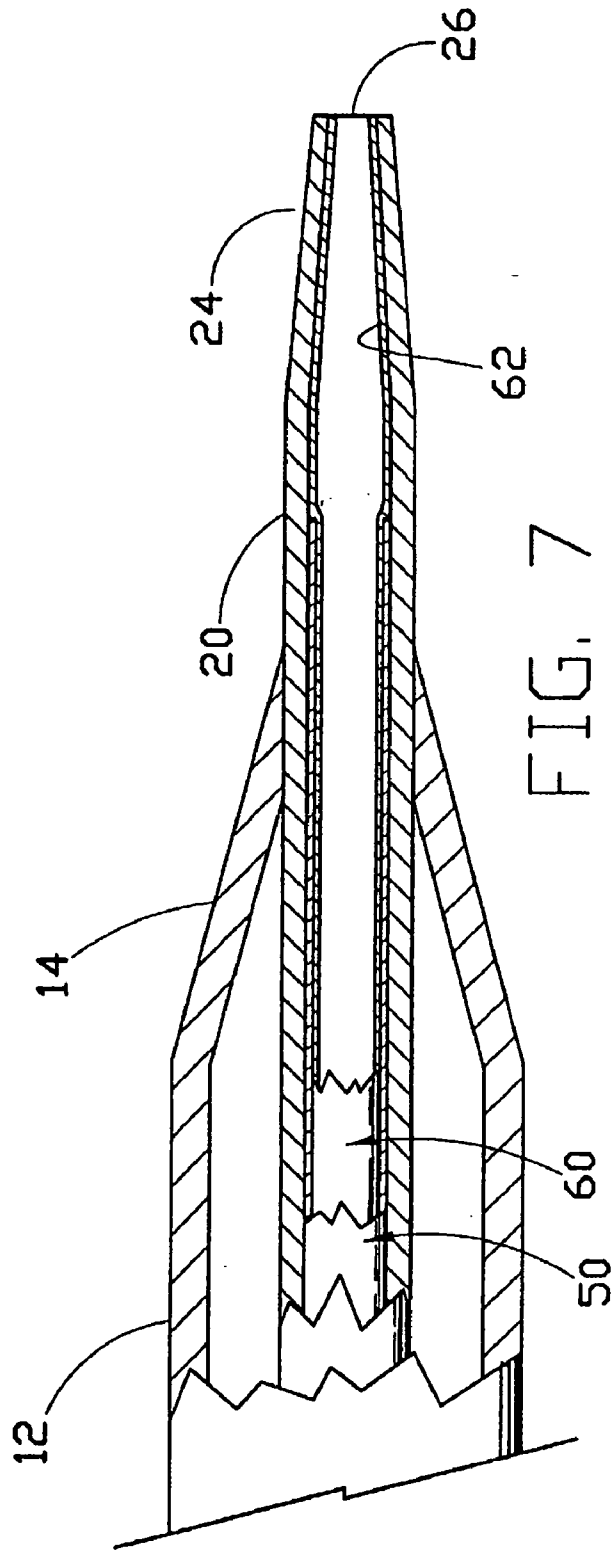

FIG. 3





PRIOR ART



SMALL GAUGE NEEDLE CATHETERIZATION APPARATUS

RELATED APPLICATION

[0001] The present patent document claims the benefit of the filing date under 35 U.S.C. §119(e) of Provisional U.S. Patent Application Ser. No. 60/484,414, filed Jul. 2, 2003, which is hereby incorporated by reference.

BACKGROUND

[0002] 1. Technical Field

[0003] The present application relates to the field of percutaneous catheterization of blood vessels.

[0004] 2. Background Information

[0005] Many medical procedures require the percutaneous placement of a medical device, such as a catheter, in a vein or an artery. Such catheters are used for, among other things, blood pressure monitoring, blood sampling and the administration of drugs and fluids to a patient.

[0006] Typically, such catheters are introduced using the well-known Seldinger percutaneous entry technique. In the Seldinger technique, the physician makes an oblique entry into the vein or artery with a beveled needle. A wire guide is then inserted through the bore of the needle about 5 to 10 cm into the passageway. The needle is thereafter withdrawn, leaving the wire guide in place. The catheter is inserted over the wire guide, and advanced through the skin into the vein or artery at the needle puncture site. Once the catheter is in place, the wire guide is withdrawn.

[0007] Conventional wire guides are normally comprised of a tightly wound helical stainless steel wire coil. In order to have sufficient rigidity to properly support and lead many standard catheters and other interventional devices, such wire guides are typically constructed to have an outer diameter (O.D.) of about 0.035 or 0.038 inch (0.89 or 0.97 mm). The most common sized needle used for initial vascular access and introduction of a standard 0.035 or 0.038 inch wire guide is an 18 gauge (0.052 inch; 1.32 mm O.D.) thin-walled needle. The 18 gauge needle has become the standard needle for use with the Seldinger technique for percutaneous catheterization. However, the outer diameter of an 18 gauge needle is just large enough to cause bleeding or other organ damage if it does not enter the vessel correctly, or if it inadvertently penetrates some other organ.

[0008] Because of the unavoidable tissue trauma that results from insertion of a needle, particularly a lancet beveled needle of the type commonly used in the Seldinger technique, it would be desirable if a smaller needle could be used to effect the initial entry. A 22 or 21 gauge (0.028 inch or 0.032 inch; 0.72 mm or 0.81 mm O.D.) needle has an outer diameter that is small enough that regardless of where the needle goes, only minimal, if any, complications are likely to occur. In addition, needles having smaller outer diameters (such as 22 or 21 gauge needles), are generally provided with a correspondingly shorter bevel at the needle tip compared to the size of the bevel tip of an 18 gauge needle. It is easier to get a short bevel into the lumen of a small vessel than the longer bevel of the 18 gauge needle.

(0.89 mm or 0.97 mm) diameter wire guide therethrough. The largest wire guide that can be easily introduced into such small gauge needles is a wire of 0.018 inch (0.46 mm) outer diameter. However, as stated, many diagnostic and interventional devices need at least a 0.035 inch (0.89 mm), and more preferably a 0.038 inch (0.97 mm), diameter wire guide to be able to optimally introduce and manipulate such devices through the vasculature.

[0009] U.S. Pat. No. 4,650,472 ("the '472 patent"), assigned to the assignee herein, describes a catheterization apparatus which allows a smaller gauge needle, such as a 22 gauge (0.028 inch; 0.72 mm O.D.) needle, to be used for percutaneous insertion of standard catheters and catheter-introducing sheaths of up to a size of at least 9 French (0.118 inch; 3.0 mm). The '472 patent is incorporated by reference herein. In the apparatus described in the '472 patent, a removable inner cannula is provided over the wire guide but inside the catheter. This removable inner cannula has a tapered tip which extends through the distal opening of the catheter, and provides a diametrical transition between the large distal opening of the catheter and an 0.018 inch wire guide. The inner cannula is about 0.038 inch (0.97 mm) O.D., and the catheter is tapered to fit over the inner cannula. The catheter and the inner cannula are inserted into the blood vessel in unison, whereby the smooth diametrical transition of the leading end minimizes the trauma that may otherwise be caused by the insertion of the large diameter catheter over the small diameter wire guide in the absence of such a transition area. Once the catheter is properly positioned within the blood vessel, the inner cannula and the smaller wire guide can be withdrawn, leaving the catheter in place. A 0.035 or a 0.038 inch (0.89 or 0.97 mm) wire guide can then be introduced through the catheter and into the vessel.

[0010] Thus, the apparatus of the '472 patent can be successfully used to percutaneously insert a catheter into a blood vessel using a wire guide and an introducer needle which are much smaller in diameter than the distal opening of the catheter. This ensures good flow characteristics for the catheter and a minimum of tissue trauma to the patient. It also allows for the introduction of larger diagnostic and interventional devices than would otherwise be possible when an initial entry is made with a small diameter needle.

[0011] In many cases when a catheter is to be inserted, it is necessary to make the puncture through tough, fibrous tissue, such as scar tissue, muscle tissue and the like. In such cases it is sometimes desired to further enhance the rigidity or column strength of a two-part dilator system such as that described in the '472 patent, so that the apparatus can be more easily pushed through the puncture site and the vessel wall. In order to enhance this rigidity, it is known to position a thin needle stiffening cannula within the lumen of the inner cannula of the apparatus of the '472 patent. The stiffening cannula generally extends from the proximal end of the apparatus up to about 1 or 2 mm proximal of the distal end opening. This cannula provides extra stiffness to the apparatus without adding significant bulk, complexity or additional parts.

[0012] The apparatus described in the '472 patent, as well as the modified apparatus that includes the stiffening cannula, are available from Cook Incorporated, of Bloomming-

Explore Litigation Insights

Docket Alarm provides insights to develop a more informed litigation strategy and the peace of mind of knowing you're on top of things.

Real-Time Litigation Alerts



Keep your litigation team up-to-date with **real-time alerts** and advanced team management tools built for the enterprise, all while greatly reducing PACER spend.

Our comprehensive service means we can handle Federal, State, and Administrative courts across the country.

Advanced Docket Research



With over 230 million records, Docket Alarm's cloud-native docket research platform finds what other services can't. Coverage includes Federal, State, plus PTAB, TTAB, ITC and NLRB decisions, all in one place.

Identify arguments that have been successful in the past with full text, pinpoint searching. Link to case law cited within any court document via Fastcase.

Analytics At Your Fingertips



Learn what happened the last time a particular judge, opposing counsel or company faced cases similar to yours.

Advanced out-of-the-box PTAB and TTAB analytics are always at your fingertips.

API

Docket Alarm offers a powerful API (application programming interface) to developers that want to integrate case filings into their apps.

LAW FIRMS

Build custom dashboards for your attorneys and clients with live data direct from the court.

Automate many repetitive legal tasks like conflict checks, document management, and marketing.

FINANCIAL INSTITUTIONS

Litigation and bankruptcy checks for companies and debtors.

E-DISCOVERY AND LEGAL VENDORS

Sync your system to PACER to automate legal marketing.