



US 20040236215A1

(19) **United States**

(12) **Patent Application Publication**

Mihara et al.

(10) **Pub. No.: US 2004/0236215 A1**

(43) **Pub. Date: Nov. 25, 2004**

(54) **CATHETER**

Publication Classification

(75) Inventors: **Nobuaki Mihara**, Shizuoka (JP);
Makoto Muto, Saitama (JP)

(51) **Int. Cl.⁷ A61B 6/00**

(52) **U.S. Cl. 600/434; 604/528; 604/529**

Correspondence Address:

BURNS DOANE SWECKER & MATHIS L L P

POST OFFICE BOX 1404

ALEXANDRIA, VA 22313-1404 (US)

(57) **ABSTRACT**

Disclosed is a catheter for penetrating a stenotic lesion occurred in a lumen in a human body, including:

a linear wire; and

a tubular body placed on a distal end side of the wire and allowing a guide wire to be inserted through its hollow portion.

(73) Assignee: **TERUMO KABUSHIKI KAISHA**,
Shibuya-ku (JP)

(21) Appl. No.: **10/798,400**

(22) Filed: **Mar. 12, 2004**

(30) **Foreign Application Priority Data**

Mar. 14, 2003 (JP) 2003-070808

The catheter of the present invention is excellent in push-in property, capable of easily and rapidly penetrating a stenotic lesion, and capable of being exchanged with a balloon catheter easily and rapidly.

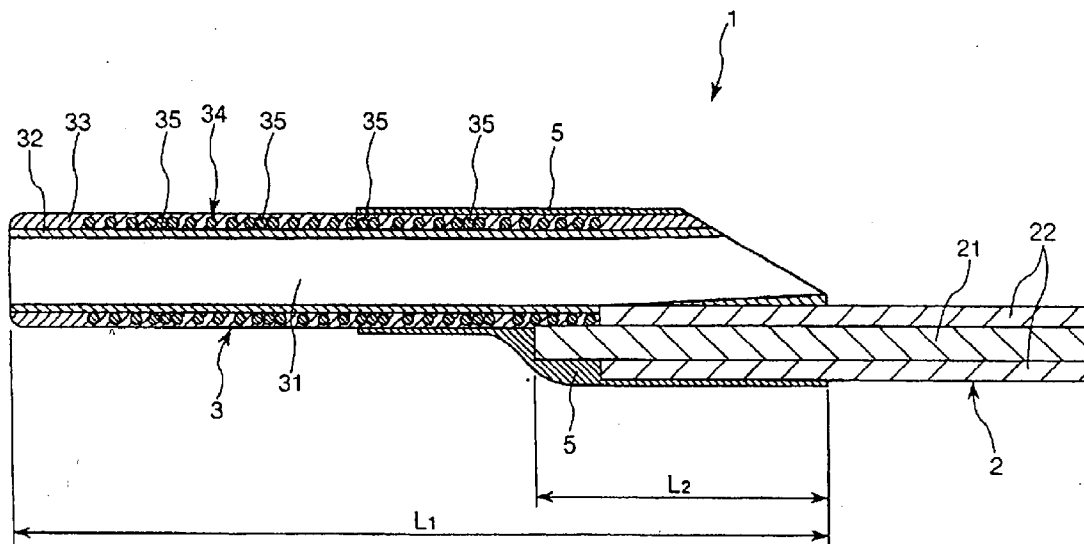

FIG. 1

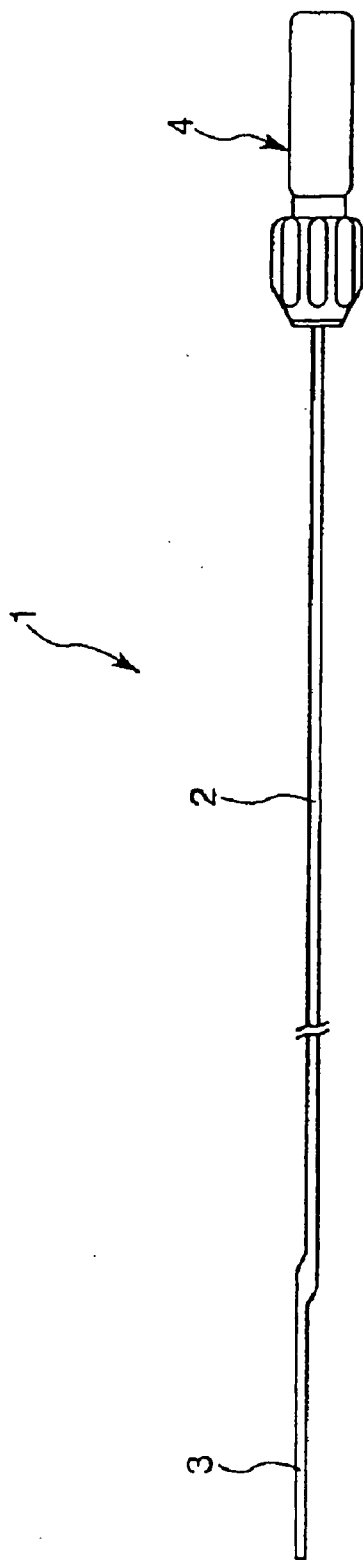

FIG. 2

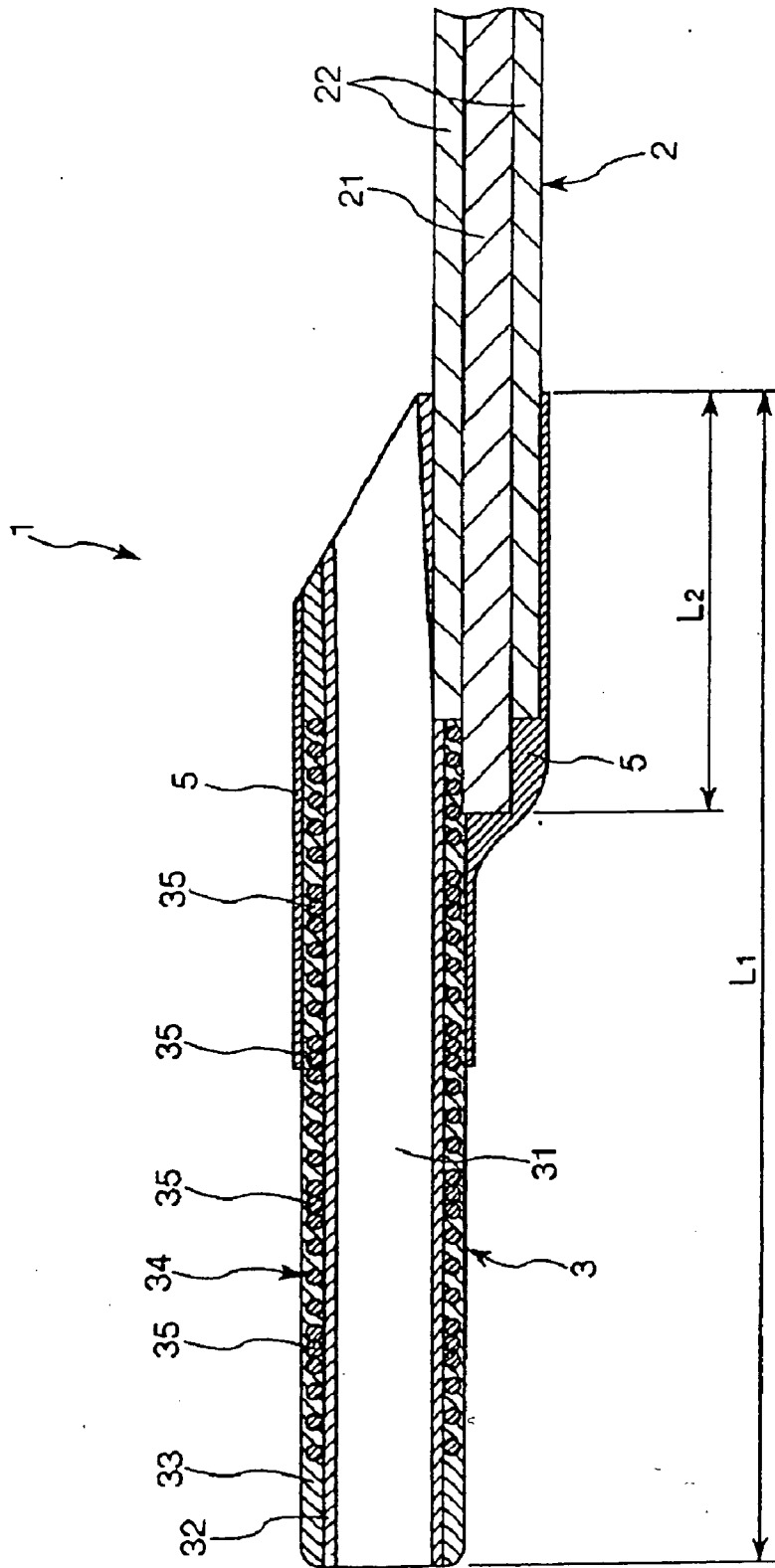
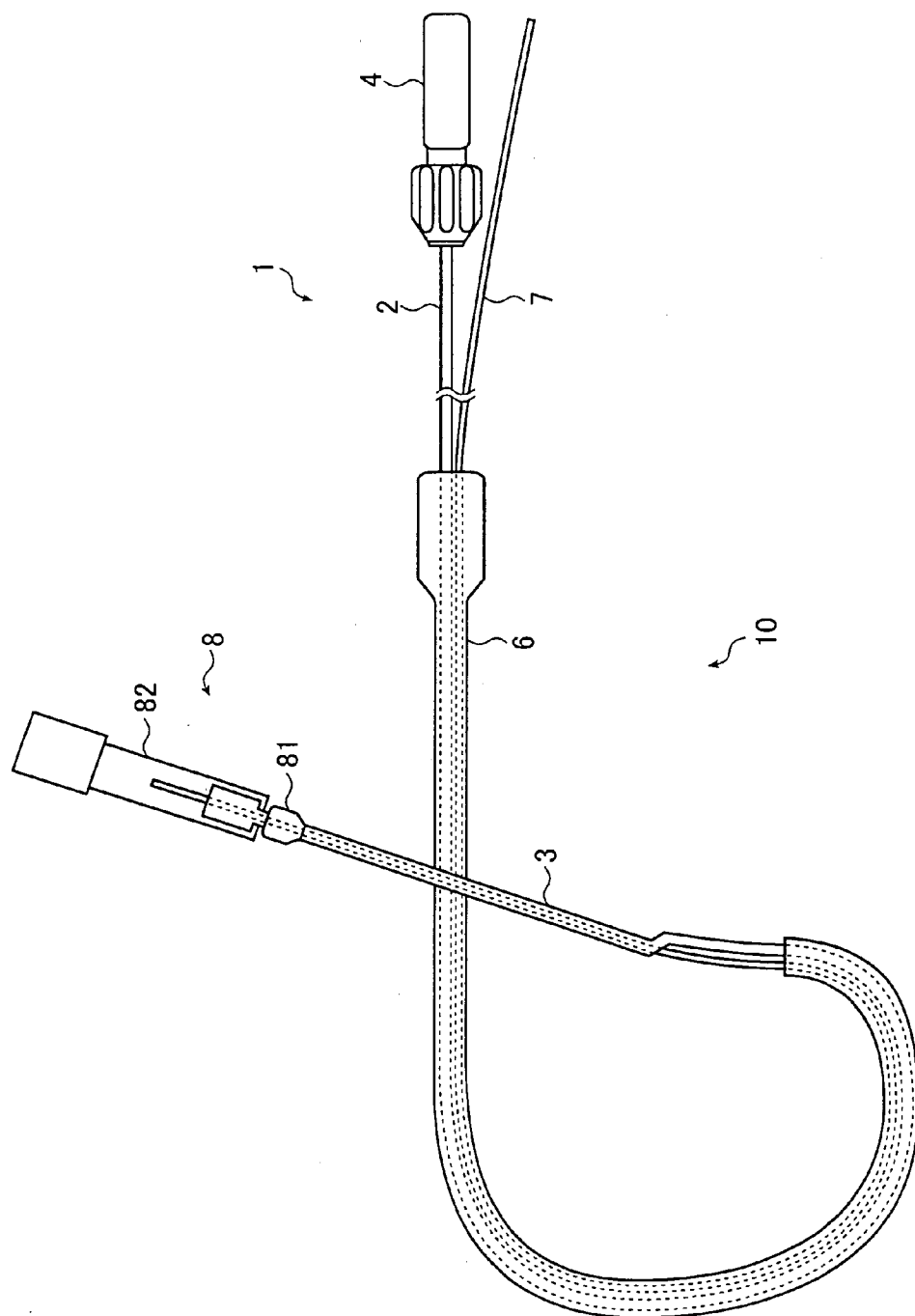

FIG. 3



CATHETER

BACKGROUND OF THE INVENTION

[0001] 1. Field of the Invention

[0002] The present invention relates to a catheter for penetrating a stenotic lesion or an occluded lesion occurred formed in a lumen in the human body.

[0003] 2. Related Background Art

[0004] For example, in the case where stenosis or occlusion is occurred in a lumen in the human body, such as a blood vessel, a bile duct, a trachea, an esophagus, or an urethra, a treatment for opening the stenosis or occlusion to recover the functions of these organs is required. Angioplasty applied to an ischemic heart disease will be described as an example of such a treatment.

[0005] Owing to the rapid increase in number of patients of ischemic heart diseases (angina pectoris, myocardial infarct, etc.) due to westernization of dietary habits in Japan, percutaneous transluminal coronary angioplasty (PTCA) is performed as a method for alleviating such diseases and is rapidly spreading. The PTCA is the following procedure. A small incision is formed in an artery of a leg or an arm of a patient, and an introducer sheath (introduction unit) is placed therein. While a guide wire is allowed to travel first through a lumen of the introducer sheath, a long hollow tube called a guide catheter is inserted in a blood vessel, and placed at an entrance of a coronary artery. After that, the guide wire is pulled out, and another guide wire and a balloon catheter are inserted in a lumen of the guide catheter. While the guide wire is allowed to travel first, the balloon catheter is allowed to proceed to a lesion (stenotic lesion part or occluded lesion) of the coronary artery of the patient by visualization with an X-ray. A balloon is positioned in the lesion. A doctor inflates the balloon at that position once or a plurality of times at a predetermined pressure for about 30 to 60 seconds. As a result, the lumen of the blood vessel in the lesion is opened, whereby the amount of blood flowing through the lumen of the blood vessel increases.

[0006] However, in the case where the stenosis of a lesion is tight, and the lesion is substantially occluded, a balloon catheter may not be able to pass through the lesion.

[0007] Thus, a catheter (for penetrating a coronary artery) for previously penetrating a lesion before inserting a balloon catheter has been developed (e.g., see JP 2002-301161 A). This catheter has a tubular body having a guide wire lumen and a port provided on a proximal end side of the tubular body, and is configured so as to insert a guide wire in the guide wire lumen from the port.

[0008] However, according to the catheter described in JP 2002-301161 A, the guide wire lumen is formed over the entire length of the catheter. Therefore, to exchange the catheter with a balloon catheter with the guide wire placed in the blood vessel, it is required that the length of the guide wire be set to be twice or more the entire length of the catheter. When the catheter is pulled out from the blood vessel, it is required that the catheter be operated along such a long guide wire as described above. The requirement

[0009] Furthermore, the catheter described in JP 2002-301161 A is composed of a hollow tubular member over the entire length, so that the catheter is highly soft (flexible) over the entire length. Therefore, a push-in force applied from a hand side (port) is difficult to be transmitted, and the catheter may have difficulty in penetrating stenotic lesion.

SUMMARY OF THE INVENTION

[0010] An object of the present invention is to provide a catheter excellent in push-in property, capable of easily and rapidly penetrating a stenotic lesion, and capable of being exchanged with a balloon catheter easily and rapidly.

[0011] The above-mentioned object is achieved by the following (1) to (10).

[0012] (1) A catheter for penetrating a stenotic lesion occurred in a lumen in a human body, including:

[0013] a linear wire; and

[0014] a tubular body placed on a distal end side of the wire and allowing a guide wire to be inserted through its hollow portion.

[0015] (2) The catheter according to the above (1), in which the wire has a metal wire and a covering layer composed of a resin material covering an outside of the metal wire.

[0016] (3) The catheter according to the above (1) or (2), in which the wire has a surface layer composed of a hydrophilic material covering an outer surface of the wire.

[0017] (4) The catheter according to any one of the above (1) to (3), in which the tubular body includes a plurality of markers each having a visualization property arranged in a longitudinal direction.

[0018] (5) The catheter according to any one of the above (1) to (4), in which the tubular body has an inner layer positioned on an inner circumferential side, an outer layer formed on an outer circumferential side of the inner layer, and a reinforcing body placed between the inner layer and the outer layer.

[0019] (6) The catheter according to any one of the above (1) to (5), further including an operation portion placed on a proximal end side of the wire.

[0020] (7) The catheter according to the above (6), in which the operation portion can be adjusted and fixed for its position with respect to the wire.

[0021] (8) The catheter according to the above (6), in which the operation portion is adhered to the wire.

[0022] (9) The catheter according to any one of the above (1) to (8), in which the tubular body is placed with its center decentered with respect to a center of the wire.

[0023] (10) The catheter according to any one of the above (1) to (9), in which the wire is connected to the tubular body under a condition that a distal end portion of the wire partially overlaps with a proximal end portion of the tubular body.

[0024] As described below, the catheter of the present invention has an excellent push-in property. Therefore, a push-in force applied from a proximal end side is transmitted to a distal end portion exactly, and as a result, the catheter

Explore Litigation Insights

Docket Alarm provides insights to develop a more informed litigation strategy and the peace of mind of knowing you're on top of things.

Real-Time Litigation Alerts



Keep your litigation team up-to-date with **real-time alerts** and advanced team management tools built for the enterprise, all while greatly reducing PACER spend.

Our comprehensive service means we can handle Federal, State, and Administrative courts across the country.

Advanced Docket Research



With over 230 million records, Docket Alarm's cloud-native docket research platform finds what other services can't. Coverage includes Federal, State, plus PTAB, TTAB, ITC and NLRB decisions, all in one place.

Identify arguments that have been successful in the past with full text, pinpoint searching. Link to case law cited within any court document via Fastcase.

Analytics At Your Fingertips



Learn what happened the last time a particular judge, opposing counsel or company faced cases similar to yours.

Advanced out-of-the-box PTAB and TTAB analytics are always at your fingertips.

API

Docket Alarm offers a powerful API (application programming interface) to developers that want to integrate case filings into their apps.

LAW FIRMS

Build custom dashboards for your attorneys and clients with live data direct from the court.

Automate many repetitive legal tasks like conflict checks, document management, and marketing.

FINANCIAL INSTITUTIONS

Litigation and bankruptcy checks for companies and debtors.

E-DISCOVERY AND LEGAL VENDORS

Sync your system to PACER to automate legal marketing.