

John Leonard: Professional Background



Education:

- University of Pennsylvania, BSEE (1983-87)
- University of Oxford, DPhil (1987-91) [Mobile Robotics]

History of MIT Positions:

- MIT Sea Grant AUV Lab 1991-1996
- Dept. of Ocean Engineering 1996-2004
- Dept of Mechanical Engineering in 2005-present
- Computer Science and Artificial Intelligence Laboratory

Current Responsibilities:

- Area Head for Ocean Science and Engineering
- Director, Ford-MIT Alliance

Research Interests:

- Mapping, Navigation, and Control of Autonomous Marine Vehicles

Source Code

- **Source code is a set of computer instructions**
- **Includes comments**
- **Written using a human-readable computer language**

```
#include <stdio.h>

/* a simple C program to print out "hello, world" */

main()
{
    printf("hello, world\n");
}
```

DigiFIN: Lateral Control Software Overview

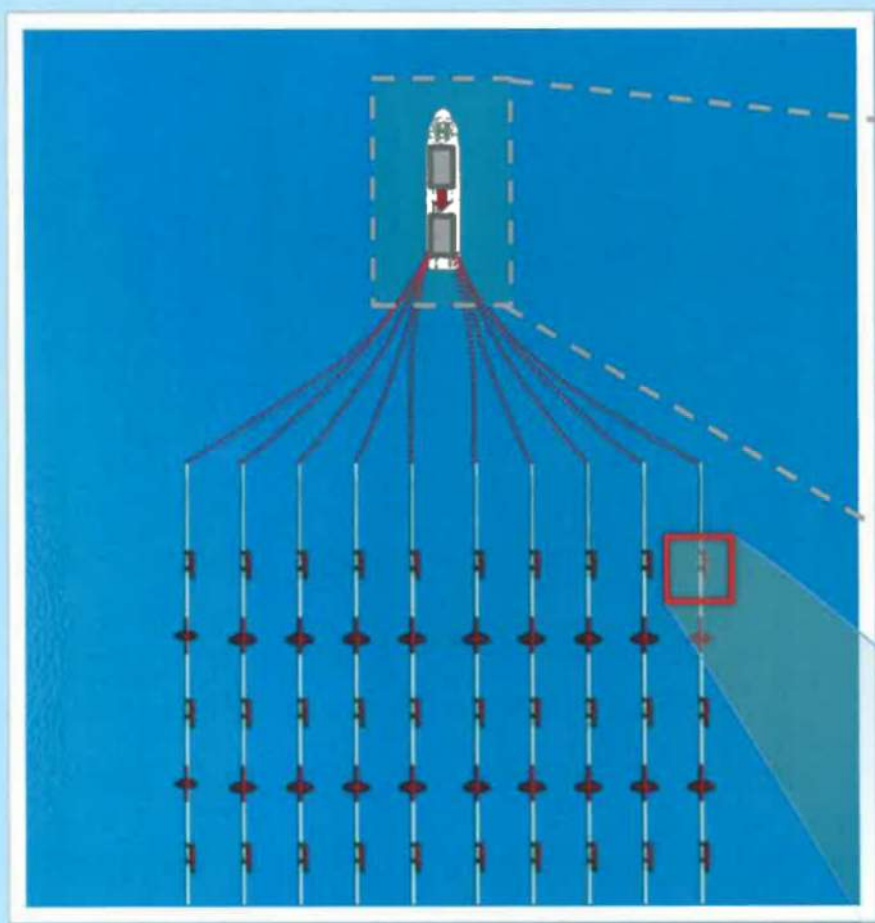

DigiFIN Hardware & Software

Motors Ac

1101101110 01100011101110000101 0011110000111100111101110000011100110001111011110001

Hardware

- Sensors
 - Temperature
 - Depth
 - Wing Angle
 - Pitch
 - Roll
- Motor
- Microcontroller

Software

- C Language
- Assembler
- Fin Commands
- Backoff Algorithm
- Out Of Bounds Conditions

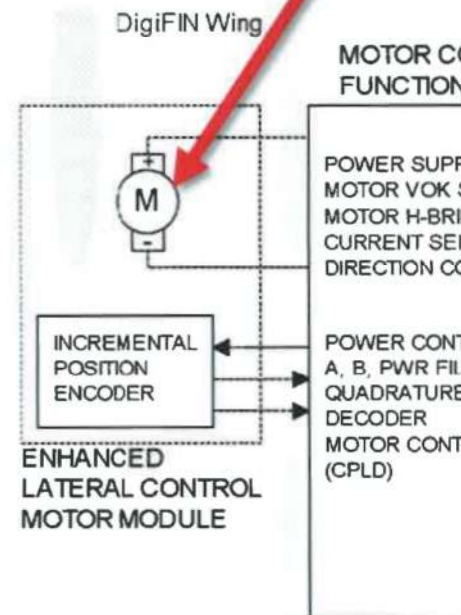

Explore Litigation Insights

Docket Alarm provides insights to develop a more informed litigation strategy and the peace of mind of knowing you're on top of things.

Real-Time Litigation Alerts



Keep your litigation team up-to-date with **real-time alerts** and advanced team management tools built for the enterprise, all while greatly reducing PACER spend.

Our comprehensive service means we can handle Federal, State, and Administrative courts across the country.

Advanced Docket Research



With over 230 million records, Docket Alarm's cloud-native docket research platform finds what other services can't. Coverage includes Federal, State, plus PTAB, TTAB, ITC and NLRB decisions, all in one place.

Identify arguments that have been successful in the past with full text, pinpoint searching. Link to case law cited within any court document via Fastcase.

Analytics At Your Fingertips



Learn what happened the last time a particular judge, opposing counsel or company faced cases similar to yours.

Advanced out-of-the-box PTAB and TTAB analytics are always at your fingertips.

API

Docket Alarm offers a powerful API (application programming interface) to developers that want to integrate case filings into their apps.

LAW FIRMS

Build custom dashboards for your attorneys and clients with live data direct from the court.

Automate many repetitive legal tasks like conflict checks, document management, and marketing.

FINANCIAL INSTITUTIONS

Litigation and bankruptcy checks for companies and debtors.

E-DISCOVERY AND LEGAL VENDORS

Sync your system to PACER to automate legal marketing.