

Ex. PGS 1051

ACOUSTIC POSITIONING OF OCEANOGRAPHIC INSTRUMENTS

D.L. McKeown

Atlantic Oceanographic Laboratory
Bedford Institute of Oceanography
Dartmouth, Nova Scotia, Canada

SUMMARY

An acoustic technique for positioning oceanographic instruments in three dimensions at any point in the water column or on the ocean floor is described. The system utilizes an array of acoustic transponders on the sea floor and an acoustic source controlled by an internal clock installed on the device to be positioned. Particular consideration is given to the problem of operating such a system in areas of very rugged topography where direct acoustic paths from instrument to transponder may be obscured. Accuracy and repeatability of the technique utilizing both direct and surface reflected acoustic paths between instrument and transponder are examined experimentally. Results of an experiment to position a bottom sampling device utilizing such a multipath are presented.

INTRODUCTION

Modern oceanographic studies such as surveys with submersible or bottom sampling devices have created a demand for precise underwater navigation and positioning systems. The most practical means of achieving precise positional measurement under the ocean's surface is through the use of acoustic techniques classified as short-baseline and long-baseline acoustic positioning systems. In its minimum configuration, the former utilizes one ocean floor acoustic marker, one acoustic marker on the device to be positioned, and a hydrophone array on the support vessel and the latter two or more acoustic bottom markers, an acoustic source on the instrument to be positioned, and a single shipboard transducer. Methods of utilizing short baseline and long baseline systems have been described in the literature.¹

Within the past few years, a need has arisen at the Bedford Institute of Oceanography for a system capable of positioning instruments and equipment in the ocean and on the ocean floor with a relative accuracy or repeatability of better than 20 metres. The system must operate without any hard-wire connection to the surface, function with instruments generating significant acoustic noise, and operate in regions of very rugged bottom topography such as the Mid-Atlantic Ridge.

POSITIONING SYSTEM

The positioning technique chosen is based on the long baseline range-range concept, that is, slant ranges from a ship and instrument to two or more acoustic markers on the ocean floor are measured to determine their positions. It has been shown^{1,2} that such a system is the best choice for precision surveying and navigation. One additional advantage over short baseline bearing-bearing or range-bearing systems is that extensive nonportable transducer installations aboard ship are avoided, making the

system readily transferable between ships. The acoustic bottom markers may be either beacon pingers which emit acoustic energy at predetermined times controlled by an internal clock or acoustic transponders which respond to external acoustic interrogations but the latter are more suitable as bottom markers for this type of application because of their longer operating life on internal power sources and freedom from long-term clock drift. The acoustic unit on the instrument to be positioned may also be either a transponder or a beacon pinger. A beacon pinger was chosen since it is unaffected by high acoustic noise fields the instrument may generate and can be readily resynchronized with a shipboard clock periodically to avoid clock drift problems.

The interrogation cycle is shown in Figure 1. At time $T = 0$, the ship interrogates both transponders at a frequency f_c . Only two transponders, A and B, are shown although three are required for an unambiguous fix. Each transponder replies at its own unique frequency, f_A and f_B , to permit identification thus measuring slant ranges S_{AS} and S_{BS} . Ship position can then be found by an iterative least squares solution. Prior to deployment, a clock in the pinger attached to the instrument to be positioned is synchronized with a shipboard clock. It emits acoustic pulses at a repetition rate of τ seconds at time $T = \tau/2 + N\tau$, where N is an integer. This acoustic pulse, at a frequency f_c , interrogates the transponders which respond at frequencies f_A and f_B . Aboard ship, the instant of interrogation is known, hence, slant ranges S_{PS} , S_{PAS} and S_{PBS} are measured. After making appropriate allowance to S_{AS} for ship movement during the interval $\tau/2$, the slant range from pinger to transponder A is

$$S_{PA} = S_{PAS} - S_{AS} \quad (1)$$

and similarly slant ranges to all other transponders can be determined. Instrument position can then be found by an iterative least squares solution. If only two transponders are successfully interrogated and it is known which side of the transponder A, B baseline ship and instrument are on, their positions can be found more quickly by solving a set of spherical equations centered on the ship and transponders.

SOUND VELOCITY AND REFRACTION

The slant range measurements described above are actually travel time measurements. To convert these measured travel times to true slant ranges, sound velocity variations in the working area must be measured and each travel time converted to slant range through applications of Snell's Law to correct for refraction effects. A simpler procedure is to multiply each travel time by an appropriate value

of harmonic mean sound velocity.³ In all experiments to date, this latter approach has led to slant range errors of less than 7 metres, the peak occurring at about 6000 metres range, for ship-transponder paths and 2.5 metres error for pinger-transponder paths once the pinger is below the thermocline.

OPERATION IN RUGGED TOPOGRAPHY

In areas such as the Mid-Atlantic Ridge, bottom topography is extremely rugged, thus, there is every likelihood that pinger-transponder paths will be obscured. The transponder could be suspended sufficiently far off the bottom to 'see' over such obstructions but its position would then become uncertain. Alternately, a surface reflected or multipath signal between pinger and transponder could be used. For a pinger at (X_p, Y_p, Z_p) and a transponder at (X_T, Y_T, Z_T) , as shown in Figure 2, it can be demonstrated that the measured pinger-surface-transponder slant range, S_{PRT} , is

$$S_{PRT} = [(X_p - X_T)^2 + (Y_p - Y_T)^2 + (Z_p + Z_T + 2D)^2]^{1/2} \quad (2)$$

and the equivalent direct slant range S_{PT} is

$$S_{PT} = [(S_{PRT})^2 - 4(Z_T + D)(Z_p + D)]^{1/2} \quad (3)$$

where the reference plane for depth is a horizontal plane through the shipboard transducer at depth D .

SYSTEM HARDWARE

The acoustic transponders used are American Machine and Foundry (AMF) Model 322 units interrogated at a common frequency of 11 kHz and replying at unique frequencies from 9 to 13 kHz. They are fitted with buoyancy in the form of six 0.4-metre Corning Glass spheres, a radio beacon and a flashing light to permit recovery. The beacon pinger is an AMF Model 360 unit with an internal clock having a drift rate equivalent to 0.75 metres per day, provision for synchronization with an external clock, a repetition rate selectable from 10 to 100 seconds, and an output frequency of 11 kHz. The shipboard system is illustrated in Figure 3. The interrogation cycle is controlled by the clock and control unit. Acoustic signals are received and converted to binary coded decimal (BCD) slant ranges by an AMF Model 205 four-channel range-range receiver. These slant ranges are recorded in a number of formats as shown, as well as routed to a digital computer for real-time positioning. Several different transducer installations have been used successfully including a special purpose hull-mounted transducer, a standard 12 kHz echo sounder transducer, and a transducer mounted in a 1.22 metre Braincon V-fin.

ABSOLUTE ACCURACY

To test absolute positioning accuracy of the system, the pinger was attached to a Guildline Model 8100 conductivity-temperature-depth (CTD) instrument capable of measuring instrument depth with an accuracy of 2 metres. The instrument package

was lowered to 1000 metres and raised in 100-metre increments. At each depth, a number of acoustic interrogations were completed and pinger depth computed. Absolute depth measurement accuracy of the system defined as the standard deviation of the differences between mean change in depth measured acoustically and change in depth determined by the CTD for 20 samples was 8.4 metres, every pinger-transponder path being a direct one of the type shown in Figure 1. This error in depth determination is caused by transponder survey and range measurement errors and has been dealt with elsewhere.^{3,4}

REPEATABILITY, DIRECT AND SURFACE REFLECTED PATHS

An important parameter of an acoustic positioning system is its repeatability or ability to define the relative positions of sample stations particularly in the case of surface reflected signals. To assess repeatability, the mean acoustic depth of the Guildline CTD used in the above experiment was found at each depth increment and the difference between this depth and each individual measurement of depth computed. The standard deviation of these differences, a measure of repeatability, was 3.0 m for 482 samples.

A second experiment was carried out to examine the repeatability of three-dimensional instrument positioning and slant range measurement. A pinger, P, was moored on the bottom within a transponder triad as shown in Figure 4. The ship then steamed back and forth through this triad determining its position relative to both the acoustic transponders and radar transponders located at geodetic stations on shore as well as recording the pinger-acoustic transponder-ship slant ranges. The absolute positions of the acoustic transponders and pinger were determined by a technique described previously.^{3,4} Knowing the absolute position of the ship, transponders, and pinger, it was possible to compute the expected direct and surface reflected pinger-transponder slant ranges. Virtually all successful interrogations between the pinger and transponder ATB-3 were a result of surface reflected signals. Occasional surface reflected interrogations of transponders ATB-1 and 2 were also noted. Three-dimensional pinger coordinates and slant ranges from pinger to transponders were computed for all successful direct and surface reflected interrogations as summarized in Table 1.

No constraints were placed on ship movement during this experiment, thus, a significant portion of the fixes occurred when the ship was on or near a baseline as it passed back and forth through the triad. Such fixes introduce considerable positional error leading to a poorer repeatability than in the Guildline CTD comparison experiment where a more optimum geometry was chosen. Table 1 indicates that pinger coordinates determined by direct and surface reflected slant range measurements agree within 10 metres and the total root-mean-square variation in position does not exceed 17.6 metres in either case. The measured pinger-transponder ATB-1 and ATB-2 slant ranges show a significantly lower standard deviation than pinger to ATB-3 surface reflected slant ranges. It has been shown that range measurement accuracy is directly proportional to signal-to-noise ratio at the receiver.³ The surface reflected path has a poorer signal-to-noise ratio than direct path because of

TABLE 1. PINGER COORDINATES FOR DIRECT AND SURFACE REFLECTED INTERROGATIONS

Coordinate	No. of Fixes	Direct		Surface Reflected			#1 - #2 (m)
		Mean #1 (m)	Std. Dev. (m)	No. of Fixes	Mean #2 (m)	Std. Dev. (m)	
X _p	760	2181.6	12.6	899	2187.1	12.1	-5.5
Y _p	760	3171.4	9.4	899	3181.3	9.7	-9.9
Z _p	760	2220.6	8.0	899	2218.2	8.4	+2.4
Slant 1-P	1496	1987.9	6.6	38	2002.9*	19.4	-15.0
Slant 2-P	1413	1626.3	5.1	9	1621.8*	12.3	+4.5
Slant 3-P	5	2866.0	12.6	863	2874.7*	14.9	-8.7

* These are equivalent direct slant ranges as determined from equation (3) and pinger depth = 2218.2 metres.

increased attenuation due to longer path length.

A POSITIONING EXPERIMENT

To test the principles outlined above, an experiment was conducted in which a sampling station on the bottom at a depth of 2714 metres was chosen to generate a surface reflected path between pinger and transponder ATB-1 at a depth of 2397 metres. Onset of multipath condition was predicted to occur at a depth of 2490 metres from an examination of the cross-section of bottom topography between the drilling station and ATB-1 as shown in Figure 5. The second transponder was moored 5592 metres from ATB-1 at a depth of 2290 metres. There were no obstructions between the sample station and this transponder, hence, all interrogations were successfully completed by a direct path between pinger and transponder. The variation in ship and drill (pinger) northing and easting and drill depth as it was deployed and recovered are shown in Figure 6. The onset and cessation of multipath interrogations occurred at 2501 metres and 2515 metres pinger depth respectively as predicted from Figure 5. There was a 'cross-over' during which alternate direct and multipath signals were obtained from the pinger-ATB-1 path. Figure 6 shows that, in this region, horizontal positioning by the surface reflected path was poor initially but improved at greater pinger depths. Little cross-over error was noted in pinger depth. It was found that application of exact refraction corrections instead of using harmonic mean sound velocity to convert travel time to slant range did not significantly improve the 'cross-over' error. Computer simulations for the geometry of this station indicated that the 'cross-over' region was not caused by the algorithms used, errors in slant range measurement, or errors in determining transponder baseline length. Simulated errors in transponder or shipboard transducer depths caused the northing and easting of the drill position to be displaced upon onset of a multipath signal but did not produce the form of 'cross-over' distortion illustrated in Figure 6.

SUMMARY AND CONCLUSIONS

It has been shown that an oceanographic instrument or bottom sampling device can be positioned in three dimensions by fitting it with a suitable acoustic pinger and utilizing ocean floor acoustic transponders. In areas of very rugged topography such as the Mid-Atlantic Ridge, positioning is readily accomplished

by means of a surface reflected interrogation between pinger and transponder. The alternate solution of suspending the transponder high enough off the bottom to avoid blind areas is not viable since its position becomes very uncertain. The onset of multipath can be determined by plotting a cross-section of the bottom topography from pinger to transponder or monitoring pinger transponder slant ranges as the instrument is lowered from the surface. In all 39 lowerings of bottom sampling devices to date in rugged topography, such a multipath has been detected and used successfully for positioning. If no constraints are placed on ship movement relative to the transponder array, repeatability of pinger position is 17.6 metres by both direct and surface reflected signals from pinger to transponder. If fix geometry is optimized, that is, neither ship nor pinger near a baseline, absolute accuracy of depth measurement by direct signal path is 8.4 metres and repeatability 3.0 metres. There is a region of 'cross-over' between direct and surface reflected paths in which positioning is poor. No explanation for this 'cross-over' region has been found yet. Positioning in this region should be avoided by choosing transponder positions relative to sample stations such that the latter do not require positioning at depths corresponding to this 'cross-over' region.

REFERENCES

1. Van Clacar, H., "Acoustic position reference methods for offshore drilling," Offshore Technology Conference Proc., Houston, Texas, May 18-21, 1969, Vol. II, pp. 467-482.
2. Fain, G., "Error analysis of several bottom referenced navigation systems for small submersibles," Proc. 5th Annual Marine Technology Society Conference, Washington, D.C., June 15-18, 1969.
3. McKeown, D.L., "Survey techniques for acoustic positioning arrays," submitted to Navigation, Journal of the Institute of Navigation, 1974.
4. McKeown, D.L., and R.M. Eaton, "An experiment to determine the repeatability of an acoustic range-range positioning system," to be presented at the International Symposium on Applications of Marine Geodesy, Columbus, Ohio, June 3-5, 1974.

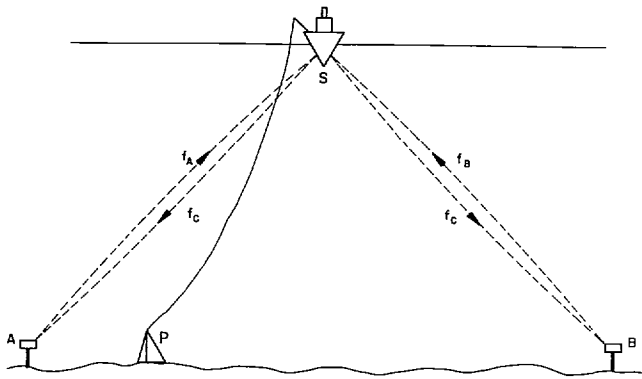

a) SHIP-TRANSPONDER-SHIP INTERROGATION AT T=0

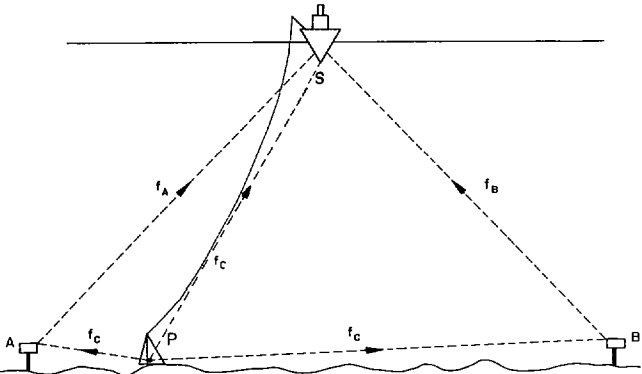

b) PINGER-TRANSPONDER-SHIP INTERROGATION AT T=0+T/2

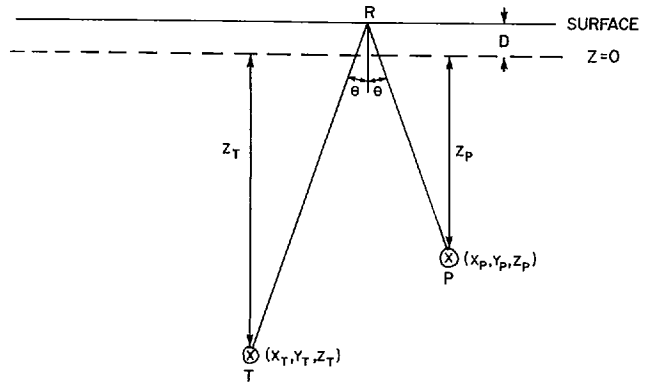
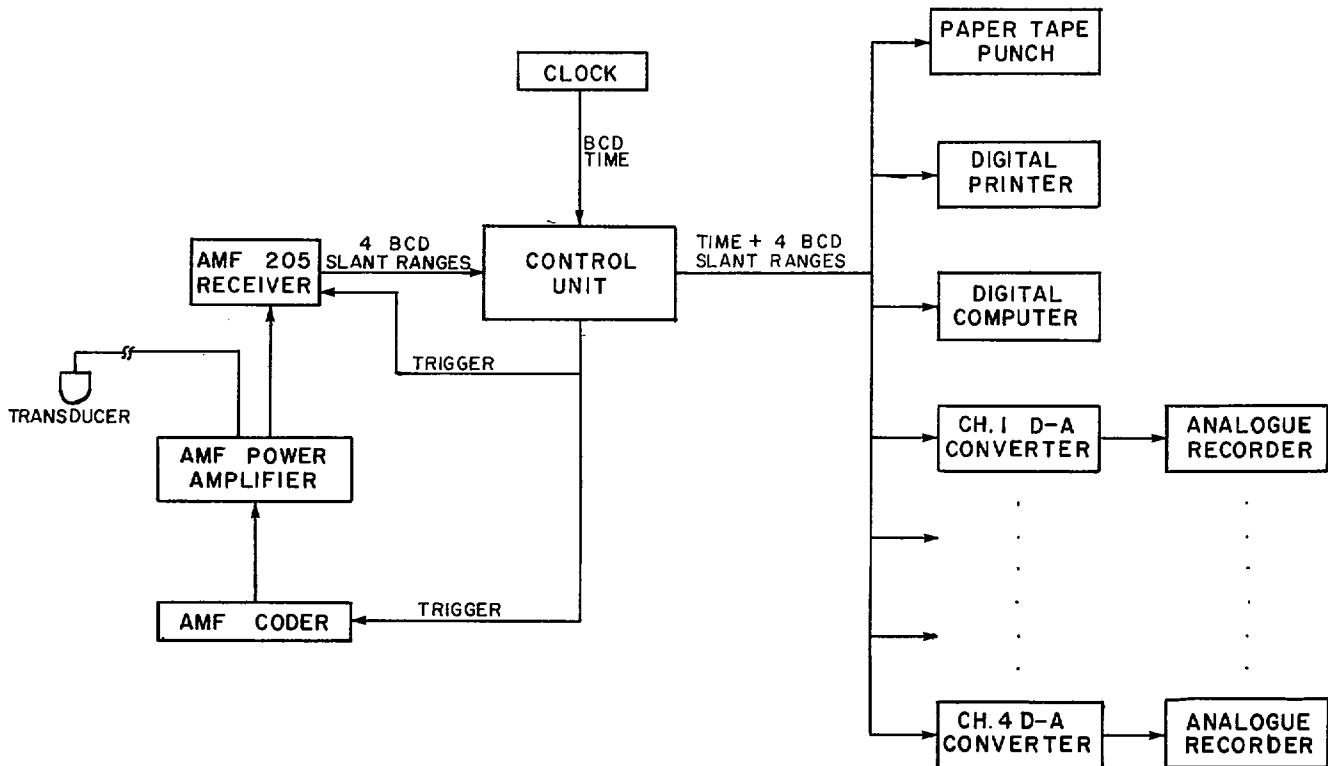

Figure 2. Surface reflected pinger (P) - surface (R) - acoustic transponder (T) signal path.

Figure 1. Acoustic signal paths for ship and pinger interrogations.



Explore Litigation Insights

Docket Alarm provides insights to develop a more informed litigation strategy and the peace of mind of knowing you're on top of things.

Real-Time Litigation Alerts



Keep your litigation team up-to-date with **real-time alerts** and advanced team management tools built for the enterprise, all while greatly reducing PACER spend.

Our comprehensive service means we can handle Federal, State, and Administrative courts across the country.

Advanced Docket Research



With over 230 million records, Docket Alarm's cloud-native docket research platform finds what other services can't. Coverage includes Federal, State, plus PTAB, TTAB, ITC and NLRB decisions, all in one place.

Identify arguments that have been successful in the past with full text, pinpoint searching. Link to case law cited within any court document via Fastcase.

Analytics At Your Fingertips



Learn what happened the last time a particular judge, opposing counsel or company faced cases similar to yours.

Advanced out-of-the-box PTAB and TTAB analytics are always at your fingertips.

API

Docket Alarm offers a powerful API (application programming interface) to developers that want to integrate case filings into their apps.

LAW FIRMS

Build custom dashboards for your attorneys and clients with live data direct from the court.

Automate many repetitive legal tasks like conflict checks, document management, and marketing.

FINANCIAL INSTITUTIONS

Litigation and bankruptcy checks for companies and debtors.

E-DISCOVERY AND LEGAL VENDORS

Sync your system to PACER to automate legal marketing.