



US006701673B1

(12) **United States Patent**
Kessler et al.

(10) **Patent No.:** US 6,701,673 B1
(45) **Date of Patent:** Mar. 9, 2004

(54) **OPENABLE AND CLOSABLE MOTOR VEHICLE WINDOW**

(75) Inventors: **Michael Kessler**, Offenbach (DE); **Peter Hagedorn**, Seeheim-Jugenheim (DE); **Hans Jürgen Salzburger**, Neunkirchen (DE); **Ansgar Wilbrand**, Rees-Haldern (DE)

(73) Assignee: **Brose Fahrzeugteile GmbH & Co. KG**, Coburg (DE)

(*) Notice: Subject to any disclaimer, the term of this patent is extended or adjusted under 35 U.S.C. 154(b) by 0 days.

(21) Appl. No.: **08/481,199**

(22) Filed: **Jun. 7, 1995**

Related U.S. Application Data

(63) Continuation of application No. 08/060,906, filed on May 12, 1993, now abandoned.

(30) **Foreign Application Priority Data**

May 13, 1992 (DE) 42 15 744

(51) **Int. Cl.**⁷ **E06B 3/00**

(52) **U.S. Cl.** **49/506**; 49/28

(58) **Field of Search** 49/26, 27, 28, 49/506

(56) **References Cited**

U.S. PATENT DOCUMENTS

- 3,727,348 A * 4/1973 Steinmann et al. 49/28
- 4,023,156 A * 5/1977 Galvin 340/274 R
- 4,351,016 A * 9/1982 Felbinger 49/28 R
- 4,458,445 A * 7/1984 Sauer et al. 49/26
- 5,229,748 A * 7/1993 Ehringer et al. 340/566
- 5,410,227 A * 4/1995 Toyozumi et al. 49/26

FOREIGN PATENT DOCUMENTS

DE	2246337	4/1974	
DE	2432063	1/1976	
DE	2127207	* 6/1978 49/28
DE	2719955	11/1978	
DE	3034118	3/1982	
DE	3136746	6/1983	
DE	3528380	2/1987	
DE	3236631	3/1988	
DE	3712950	11/1988	
DE	3438050	4/1989	
GB	1347474	* 2/1974 49/28

OTHER PUBLICATIONS

Dr. Dan Russell, "Acoustics Animations", Acoustics and Vibrations Animations page, <http://WWW.gmi.edu>, 2001.

* cited by examiner

Primary Examiner—Jerry Redman

(74) *Attorney, Agent, or Firm*—Christie, Parker & Hale, LLP

(57) **ABSTRACT**

Device for restricting or controlling and regulating the movement of remote-controlled parts, more particularly parts of a vehicle bodywork as well as a process for operating the device. The device and process can be used with particular advantage as a collision protection for window winders, sunroofs, doors or flaps, more particularly in connection with electrical displacement devices for motor vehicles. The device is characterized by an actuator and a sensor which are mounted on a cohesive uninterrupted transmission path which is a constituent part of the closing surface area of the remote-controlled part and/or of the fixed part interacting therewith. The arrangement is selected so that a part of the energy supplied by actuator is converted into acoustic surface waves which can scatter over the transmission path and can be received by the sensor.

20 Claims, 6 Drawing Sheets

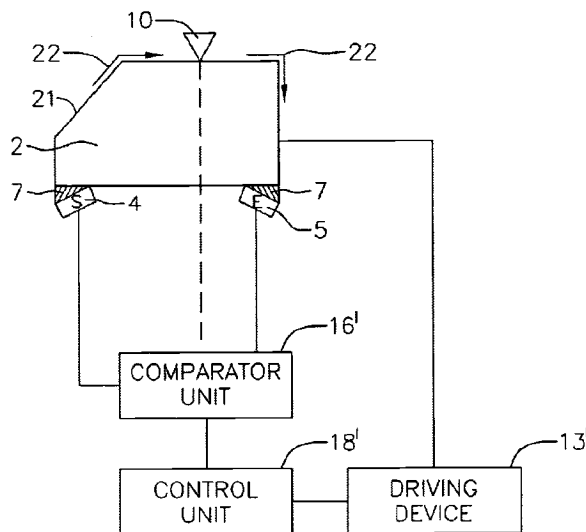

UUSI, LLC
Exhibit 2032

WEBASTO ROOF
SYSTEMS, INC.
Petitioner
v.
UUSI, LLC
Patent Owner

Case:
IPR2014-00648
Patent: 8,217,612

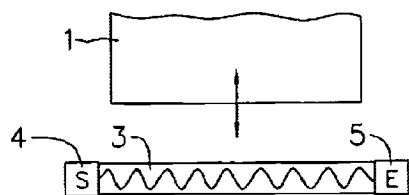

FIG. 1a

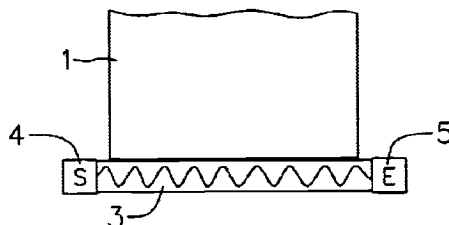

FIG. 1b

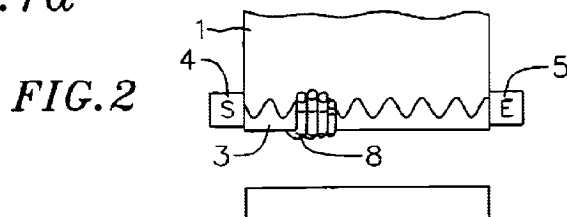

FIG. 2

FIG. 3a

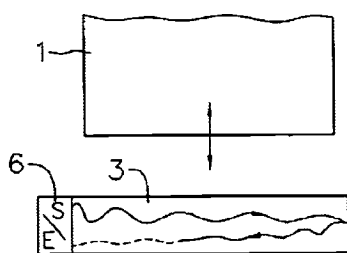

FIG. 3b

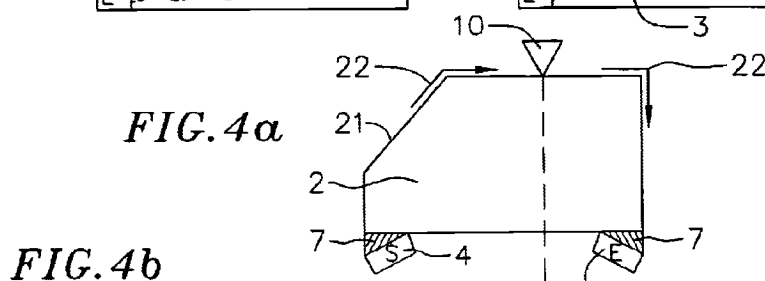
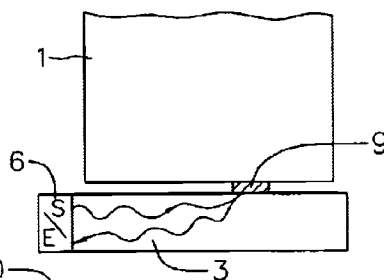

FIG. 4b

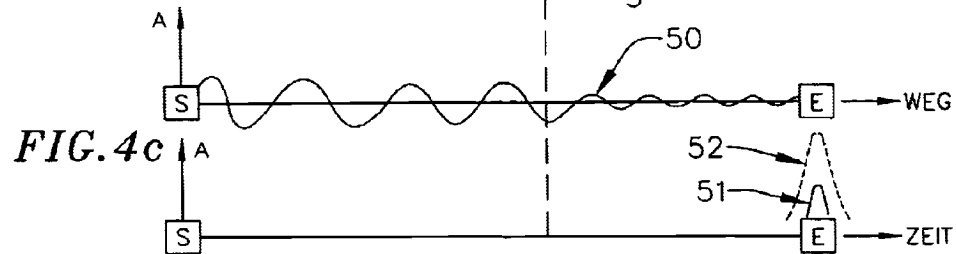
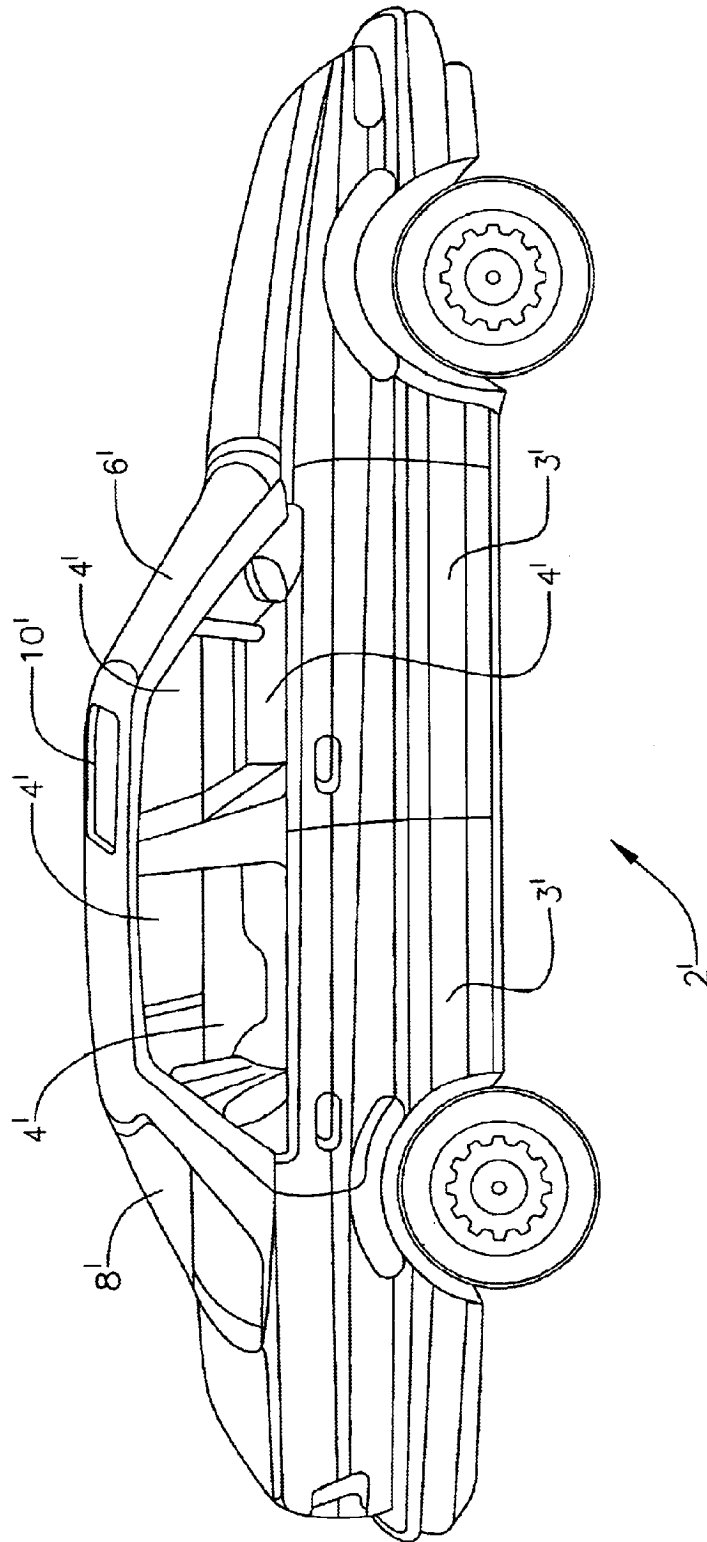

FIG. 4c

FIG. 1aa



U.S. Pat. No. 6,701,673 B1

FIG. 1 ab

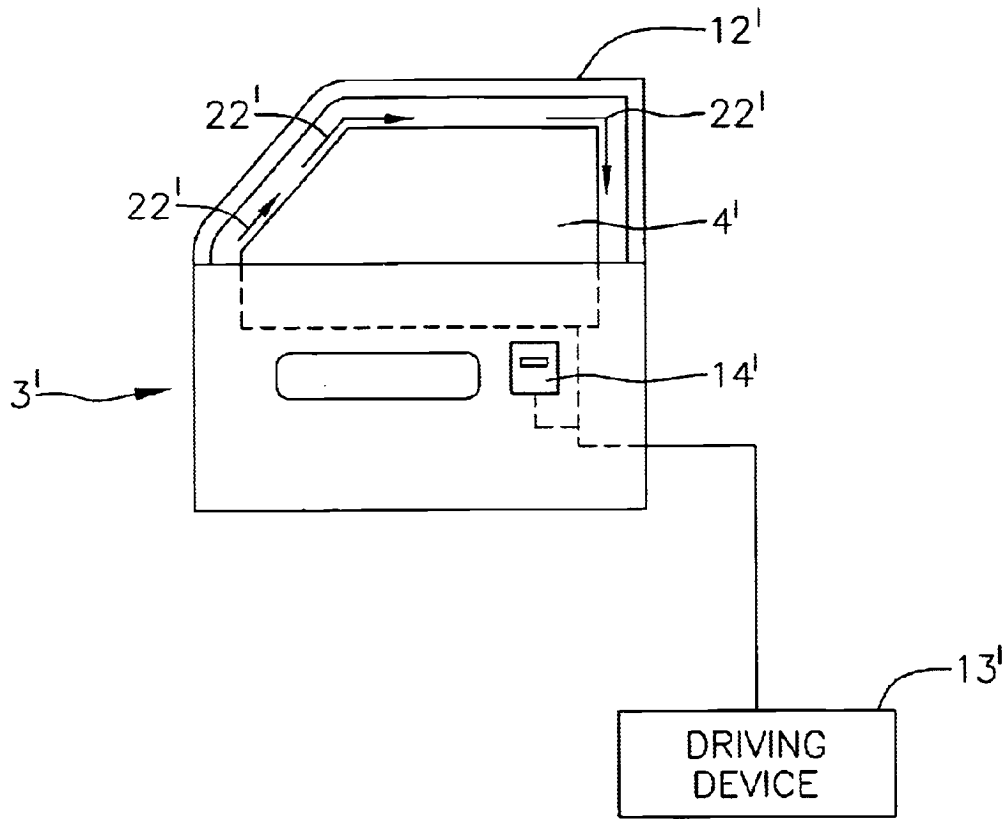

U.S. PATENT

FIG. 4a'

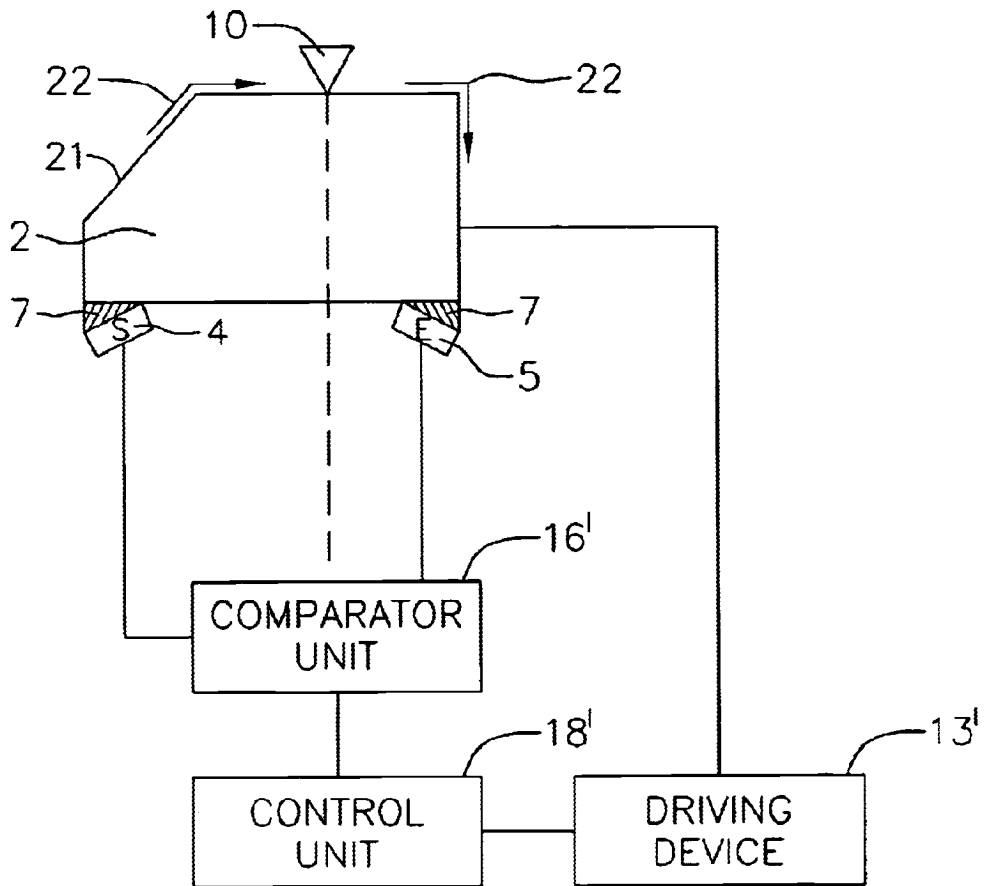

Explore Litigation Insights

Docket Alarm provides insights to develop a more informed litigation strategy and the peace of mind of knowing you're on top of things.

Real-Time Litigation Alerts



Keep your litigation team up-to-date with **real-time alerts** and advanced team management tools built for the enterprise, all while greatly reducing PACER spend.

Our comprehensive service means we can handle Federal, State, and Administrative courts across the country.

Advanced Docket Research



With over 230 million records, Docket Alarm's cloud-native docket research platform finds what other services can't. Coverage includes Federal, State, plus PTAB, TTAB, ITC and NLRB decisions, all in one place.

Identify arguments that have been successful in the past with full text, pinpoint searching. Link to case law cited within any court document via Fastcase.

Analytics At Your Fingertips



Learn what happened the last time a particular judge, opposing counsel or company faced cases similar to yours.

Advanced out-of-the-box PTAB and TTAB analytics are always at your fingertips.

API

Docket Alarm offers a powerful API (application programming interface) to developers that want to integrate case filings into their apps.

LAW FIRMS

Build custom dashboards for your attorneys and clients with live data direct from the court.

Automate many repetitive legal tasks like conflict checks, document management, and marketing.

FINANCIAL INSTITUTIONS

Litigation and bankruptcy checks for companies and debtors.

E-DISCOVERY AND LEGAL VENDORS

Sync your system to PACER to automate legal marketing.