

Engineers, Part F: Journal of Rail and Rapid Transit

<http://pif.sagepub.com/>

Diesel Locomotive Reliability Improvement by System Monitoring

K N Fry

Proceedings of the Institution of Mechanical Engineers, Part F: Journal of Rail and Rapid Transit 1995 209: 1

DOI: 10.1243/PIME_PROC_1995_209_248_02

The online version of this article can be found at:

<http://pif.sagepub.com/content/209/1/1>

Published by:



<http://www.sagepublications.com>

On behalf of:



[Institution of Mechanical Engineers](http://www.institutionofmechanicalengineers.org)

Additional services and information for *Proceedings of the Institution of Mechanical Engineers, Part F: Journal of Rail and Rapid Transit* can be found at:

Email Alerts: <http://pif.sagepub.com/cgi/alerts>

Subscriptions: <http://pif.sagepub.com/subscriptions>

Reprints: <http://www.sagepub.com/journalsReprints.nav>

Permissions: <http://www.sagepub.com/journalsPermissions.nav>

>> [Version of Record](#) - Jan 1, 1995

[What is This?](#)

Diesel locomotive reliability improvement by system monitoring

K N Fry, BSc

British Rail Research, Railway Technical Centre, Derby

System monitoring for reliability (SMR) involves monitoring critical parts of a vehicle and informing the owning business of an impending fault. Diesel locomotives offer the largest opportunity for such systems and British Rail Research has developed a system designed to improve Class 47 locomotive reliability.

The vehicle-mounted equipment comprises a computer that continuously monitors the condition of the vehicle through sensors at key points. The computer is connected to a radio telephone and modem and a GPS satellite navigator. The key elements in the success of the system are the automated analysis of data on-board the vehicle and its ability to call for help ahead of the occurrence of service failures. The business interface is through a Windows based information display which runs on a personal computer connected to the public telephone network. This controls the display of messages from monitored vehicles and allows vehicles to be interrogated to check on current condition.

When fully implemented, a reduction in technical casualties of 40 per cent is anticipated. There are additional financial benefits from efficiency improvements and vehicle maintenance cost savings.

Key words: system monitoring for reliability, diesel locomotives

1 INTRODUCTION

The Vehicle Systems Unit of British Rail Research has undertaken a series of projects over many years concerned with the development of condition monitoring for railway rolling stock and diesel locomotives in particular. This work has recently concentrated on the development of systems to improve the reliability of vehicles. System monitoring for reliability (SMR) is the name given to monitoring critical parts of a vehicle in order to improve its reliability by informing the owning business of an impending fault.

This paper describes the development of a system for monitoring Class 47 locomotives. It begins with the guiding philosophy for SMR. It then goes on to describe the component parts; the on-board equipment and analysis of data; the communication of information to and from the vehicle; and the information display system. Finally, there is a review of the current position.

The MS was received on 25 November 1993 and was accepted for publication on 22 December 1994.

2 PHILOSOPHY OF SYSTEM MONITORING FOR RELIABILITY

2.1 The economic background

Studies into maintenance and maintenance-related costs of typical types of rolling stock have been undertaken to determine the most cost-effective areas for the application of condition monitoring and diagnostic systems. The four main vehicle types used by British Rail have been examined; diesel locomotives, electric locomotives, diesel and electric multiple units.

The costs have been broken down by vehicle system and subsystem into five areas, three directly associated with maintenance; exams, repairs and overhauls and two indirectly related; the cost of unreliability and unavailability. The results, given in Fig. 1, show that the largest total cost is for diesel locomotives, and the largest element of this total is the cost of unreliability.

Examination of the reasons for unreliability showed that the total is made up of a small number of causes (see Fig. 2), many of which are easily monitored and

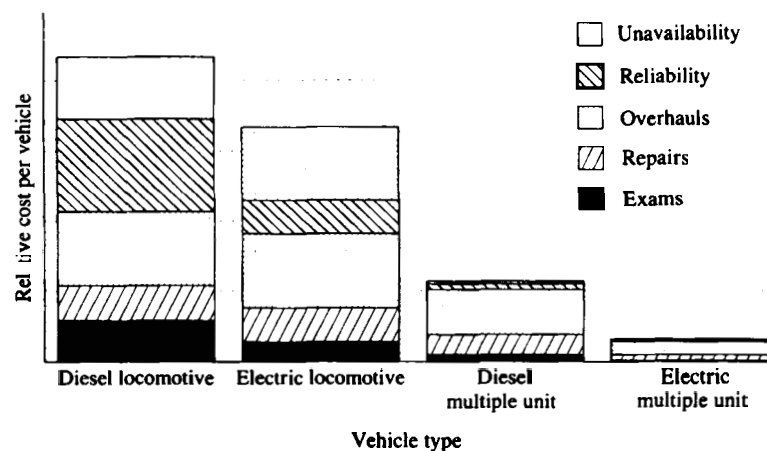

Fig. 1 Rolling stock maintenance and maintenance-affected costs

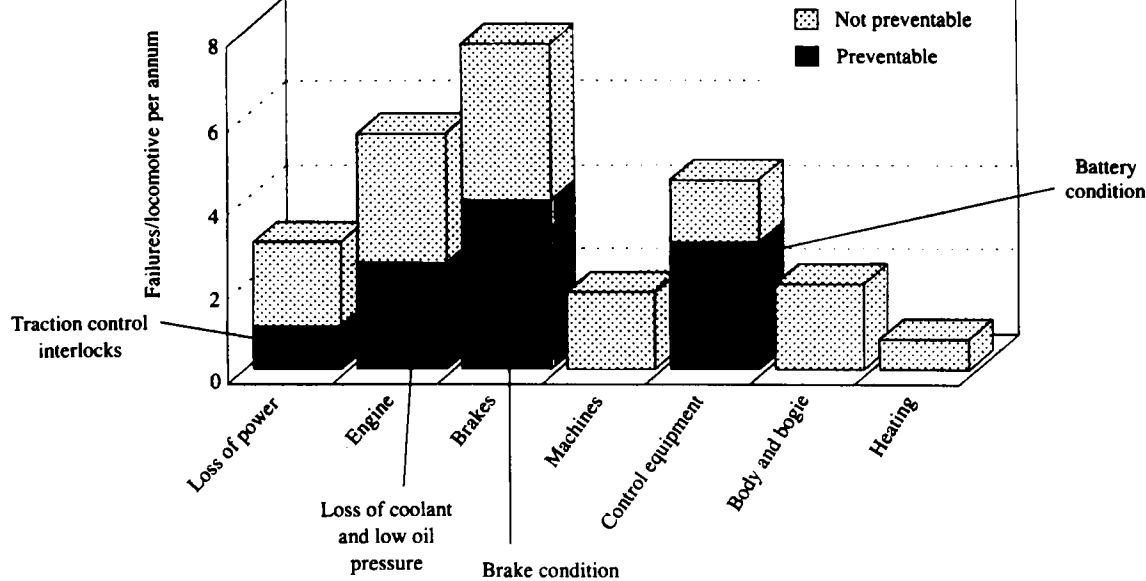

Fig. 2 Causes of Class 47 failures in service

allow warning to be given. About 40 per cent are considered preventable through appropriate monitoring and notification of impending failure.

2.2 Reliability emphasis

The factors described in Subsection 2.1 led to the concept of system monitoring for reliability which is specifically aimed at reducing in-service failure of equipment rather than reducing maintenance costs or increasing availability. This very specific approach gives a number of advantages:

- (a) the number of measurands is significantly reduced;
- (b) the maintenance philosophy of the vehicles does not change, so it is quicker and easier to implement;
- (c) data analysis is generally easier since faults severe enough to cause a vehicle to fail are more easily identified than the comparatively smaller changes associated with a need for maintenance.

2.3 Importance of on-board analysis

Most approaches to vehicle monitoring have involved fitting data logging equipment and analysing the data after they have been downloaded. This requires the routine download of a large amount of data, the majority of which will indicate that the vehicle is healthy. It also introduces a delay in fault identification and will miss the majority of faults likely to affect service reliability on a daily basis.

An emphasis on reliability improvement requires that in order to achieve a fast response to developing faults, the analysis of data must be automated and done on-board the vehicle; the vehicle must also be able to call for help. It is this requirement for a high degree of vehicle system 'intelligence', in conjunction with a communications system where the vehicle can call for help or be called at any time that is the key to successful SMR.

The move towards an 'intelligent vehicle' gives two other major benefits. Firstly, it considerably reduces the

amount of data requiring transmission, which is particularly advantageous where communication is by radio. Secondly, it opens up the possibility of providing information to the driver or train crew in those situations where it can be usefully acted upon.

The provision of a continuous communications link between the owning business and an 'intelligent vehicle' allows information on condition to be provided on demand. Such vehicle interrogation may be useful as a check on condition just prior to assignment or for monitoring the development of a fault already reported.

2.4 Information required

System monitoring is really only half the story. In order for the service reliability to be improved not only must information about a fault be provided, but the information must be suitably acted upon in order to remedy the situation. If appropriate action is not carried out, the vehicle will fail just as it would without monitoring. In this respect the presentation of information to the end user is of paramount importance.

An important part is the information content. The majority of rolling stock is maintained by means of component replacement to facilitate rapid return to service and so the information provided should support this philosophy. In other words, faults in equipment need only be diagnosed down to the level of 'replaceable unit' or the level of action required to allow the vehicle to continue running, such as 'top up with coolant'. Diagnosis to this depth is particularly important in the case of a vehicle reporting a developing fault but a long way from a repair depot. Should the vehicle be brought back to the depot, repaired at an outstation, repaired by a mobile maintenance team or left for a while? If the vehicle does need to return to depot, diagnosis to replaceable unit level allows an indication beforehand of what spares and depot resources are required (for example, under cover, crane, pit, manpower etc.) This speeds up repair time considerably. Similarly, if a mobile maintenance team needs to be sent to the vehicle they will know what equipment to take with them.

Information from the system is sent to the business maintenance controllers. They respond to calls from outstations reporting problems with vehicles and arrange repair or a replacement vehicle.

For fault diagnosis, messages should be sent from the vehicle immediately, but this is not necessarily the case when prognosis is involved. There are situations where, if the existing set of circumstances were to continue, the vehicle would fail, but the fault may be naturally remedied before it occurs. For example, a battery draining with the engine stopped may be just about to be charged following an engine start, or a vehicle with a coolant leak may be just running on to a depot to have its coolant topped up. In these circumstances the approach has been to define a failure limit and make predictions of the remaining time to failure. Messages can then be generated a set time before failure is estimated. The maintenance controller can then decide on whether the fault will require action based upon the duty of the vehicle.

3 ON-BOARD SYSTEM

3.1 Equipment fitted

The vehicle-mounted equipment comprises a computer that continuously monitors the condition of the vehicle through sensors at key points. The computer is connected to a radio telephone and modem allowing the system to ring out with fault messages or be interrogated by the owning business at any time. The com-

puter knows the vehicle's position through connection to a GPS satellite navigator.

The equipment is housed in three rugged steel enclosures sealed to IP66 and protected against the electromagnetic environment of the locomotive. Also fitted are a number of transducers mounted directly on to existing components, some small enclosures containing transducers and appropriate interconnection via high specification cable sealed into flexible conduit. Two aerials are also used, a short whip aerial mounted on the end of the vehicle, and a small flat antenna mounted on the roof for the GPS navigator. This equipment is designed to retrofit into the vehicle without interfering with its normal operation and maintenance. A general schematic is shown in Fig. 3.

3.1.1 Computer

Hardware. The on-board computer is an industry standard VME bus-based system made up of single height eurocards. The use of the VME bus standard allows a system to be made up in a very modular and flexible way using equipment from one or a number of suppliers. The system can be easily expanded to include additional processing power, memory, communications or monitoring channels.

Software. Most computers use an operating system as the master supervisor of their resources; memory, processing time and input/output devices such as sensors, modems and disk drives. The operating system also provides an interface between the computer and the

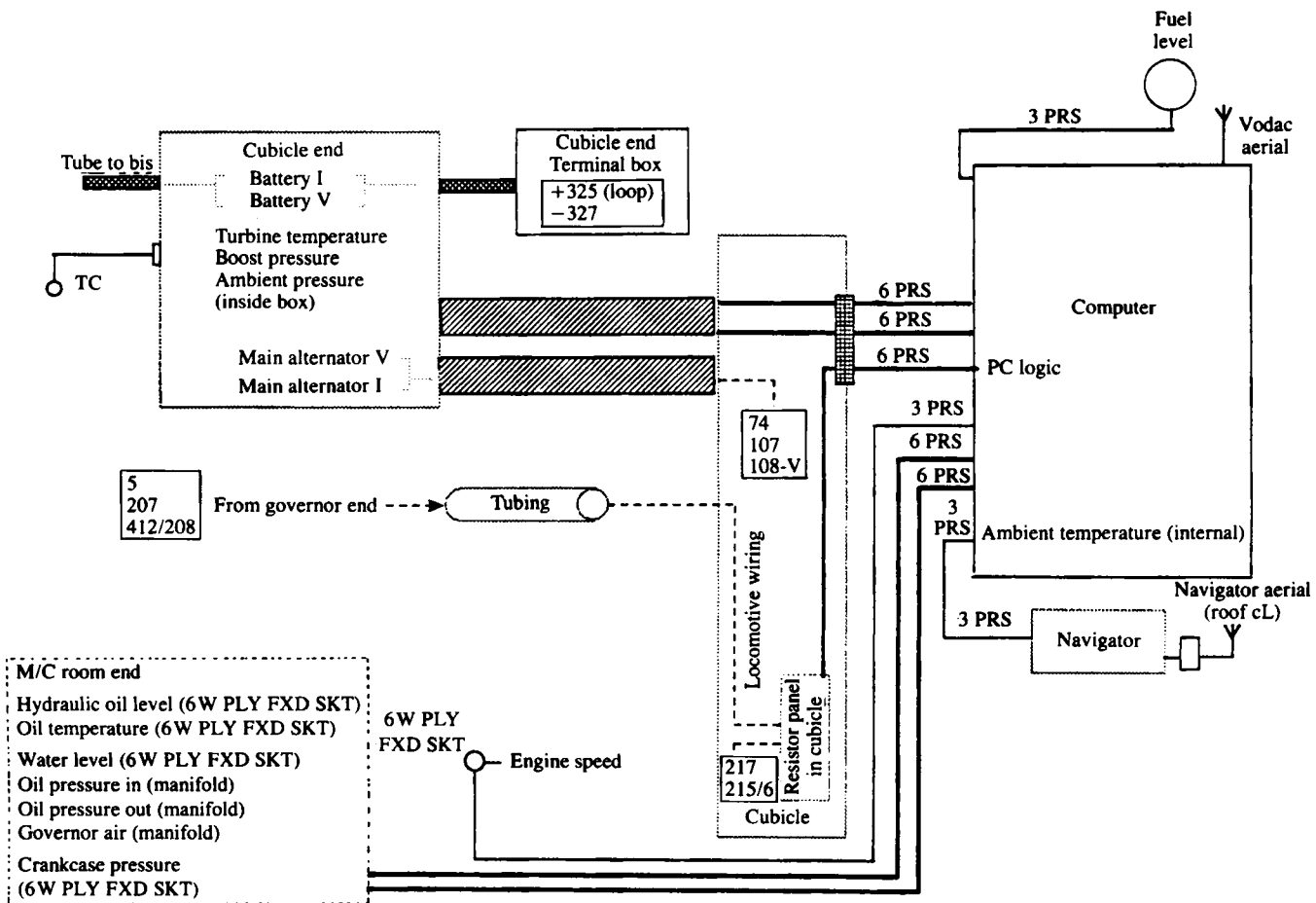

Fig. 3 Monitoring equipment general arrangement

user, managing the basic operations of the system, loading and executing programs, managing input/output, managing a directory of files and allocating memory. Application programs performing data analysis, data storage and communications all sit on top of the operating system and call on it to perform low-level tasks.

The operating system used in the on-board computer is OS-9. This is a multi-tasking operating system similar to UNIX but specifically developed for use in real time embedded systems.

Multi-tasking means that several programs may run apparently simultaneously, by rapidly switching from one program to the next many times per second. This capability is used extensively for the on-board software. It considerably simplifies the task of managing data analysis, allowing for example, communications over the radio telephone to occur while analysing data from the oil system, while reading the position from the navigator, while storing vehicle operating data to file, etc. Each task can be written as a separate program simplifying development and testing, and removing any risk of programs interfering with each other.

3.1.2 Cellular radio telephone and modem

The computer is connected to a Racal Vodafone cellular radio telephone and modem. Modems for cellular radio require a special error correction protocol, cellular data link control (CDLC), which gives 100 per cent error-free data transmission at speeds up to 2400 bits per second. The modem is configured for auto-dial and auto-answer allowing the vehicle to call out or be called at any time. Development of additional hardware and a consider-

able amount of software has been necessary to ensure reliable phone management across the two-way link.

3.1.3 GPS satellite navigator

The vehicle is equipped with a 'Navstar' XR5 GPS receiver which gives satellite-based positioning. Position information from the receiver, accurate to a mean error of 28 metres, is available to the on-board computer through a serial data link. The latitude and longitude is converted to eastings and northings by the computer.

3.2 Data analysis

The general structure of the data analysis performed is shown in Fig. 4. This structure separates the data analysis from the hardware allowing more generalized program modules to be produced.

The program 'logger' reads all the sensors and the vehicle location from the satellite navigator and writes the data to a global buffer. The buffer holds all the measurements made over the last minute.

The program 'validate' takes information from the measurement buffer and places it in a second, similar buffer after:

- converting it to engineering units;
- adjusting it for the value of supply voltage existing at the time;
- checking it against limits to ensure validity

'Validate' also sets 'flags' to identify engine operating status and transducer and power supply faults.

The analysis programs for individual systems then simply extract data from this buffer when their own criteria for analysis are met, for example the engine has

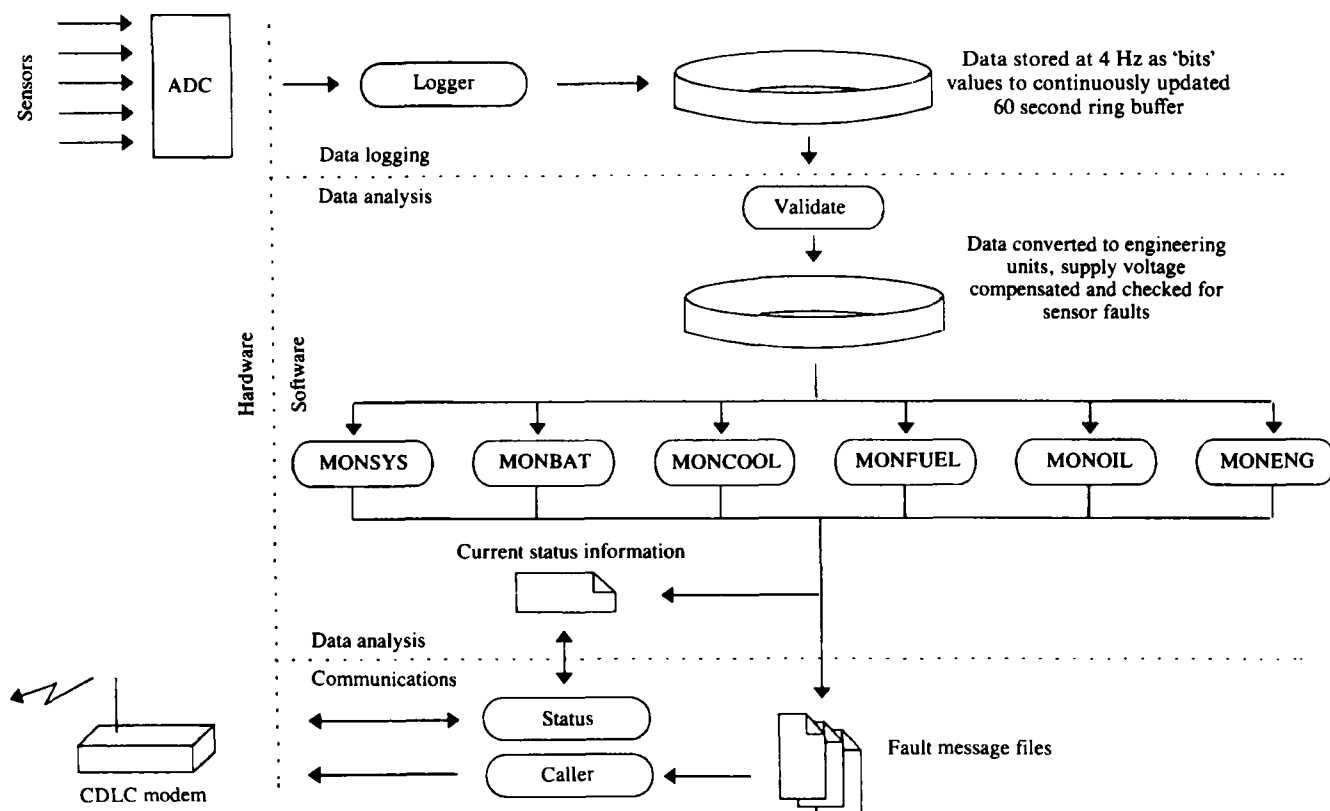

Fig. 4 Structure of DEMON SMR47 software

Explore Litigation Insights

Docket Alarm provides insights to develop a more informed litigation strategy and the peace of mind of knowing you're on top of things.

Real-Time Litigation Alerts



Keep your litigation team up-to-date with **real-time alerts** and advanced team management tools built for the enterprise, all while greatly reducing PACER spend.

Our comprehensive service means we can handle Federal, State, and Administrative courts across the country.

Advanced Docket Research



With over 230 million records, Docket Alarm's cloud-native docket research platform finds what other services can't. Coverage includes Federal, State, plus PTAB, TTAB, ITC and NLRB decisions, all in one place.

Identify arguments that have been successful in the past with full text, pinpoint searching. Link to case law cited within any court document via Fastcase.

Analytics At Your Fingertips



Learn what happened the last time a particular judge, opposing counsel or company faced cases similar to yours.

Advanced out-of-the-box PTAB and TTAB analytics are always at your fingertips.

API

Docket Alarm offers a powerful API (application programming interface) to developers that want to integrate case filings into their apps.

LAW FIRMS

Build custom dashboards for your attorneys and clients with live data direct from the court.

Automate many repetitive legal tasks like conflict checks, document management, and marketing.

FINANCIAL INSTITUTIONS

Litigation and bankruptcy checks for companies and debtors.

E-DISCOVERY AND LEGAL VENDORS

Sync your system to PACER to automate legal marketing.