

Asymmetric bipolar pulsed DC: the enabling technology for reactive PVD

J. Sellers *

ENI, 4150 Freidrich Ln., Suite J, Austin, TX 78744, USA

Abstract

The use of reactive DC sputtering for the deposition of insulators from conductive targets has been limited by the intrinsic problem of target poisoning and the consequent arcing and process instabilities. The need to deposit high quality dielectric films rapidly is becoming more important as technology pushes forward. Asymmetric bipolar pulsed DC eliminates target poisoning through preferential sputtering, enabling existing PVD tools to produce the high-quality, low-defect dielectric films needed for next generation processes. Typical films being produced with asymmetric bipolar pulsed DC from metallic targets include Al_2O_3 , AlN , SiO_2 , SiN , Ta_2O_5 , DLC , TaN , TiN and ITO . The mechanisms of target poisoning and dielectric arcing are explained in this paper, and solutions are given. © 1998 Published by Elsevier Science S.A.

Keywords: Sputter; Reactive; Magnetron; Thin film; PVD

1. Introduction

Asymmetric bipolar pulsed DC technology has been quickly proving its effectiveness in a wide variety of standard and reactive sputtering applications. Acceptance of this technology has been extremely rapid due to its elimination of many long-standing process limitations. Asymmetric bipolar pulsed DC was specifically developed to optimize the deposition of insulating films from conductive targets with reactive sputtering. Further, it is important to understand that this technology did not evolve as an afterthought to control arcing: rather, it was conceived with a definite understanding of the electrical and physical process requirements. This understanding led to a unique solution in which the power source is given the dual properties of a current source and a voltage source, depending on which plasma constituent is being driven. Thus, both ions and electrons are driven in their optimal manner, and the plasma's asymmetry of masses (ions versus electrons) is matched by the supply's source dual characteristics (current source (forward sputter) versus voltage source (reverse bias)). Films successfully reactively sputtered with this technology include Al_2O_3 , Ta_2O_5 , BST , PZT , Ta_2O_5 , TaN , TiO_2 , TiN and ITO . Additional applications for

the technique include etching/cleaning, CVD bias, and substrate bias for sputtered films.

2. Target poisoning

The key to the successful production of insulating films from metallic targets is the elimination of target poisoning. Poisoning is the build-up of insulating layers on the target surface. In simple metallic sputtering, the target (or cathode) is driven by the sputtering supply to a specific DC voltage based on the power, chamber pressure, magnetron design, etc. This voltage accelerates the argon ions into the target with sufficient kinetic energy to cause them to knock atoms from the target. The freed target atoms then condense on the substrate to form the desired film. The free atoms also deposit on the walls of the chamber and back on the target. In pure metallic sputtering, this redeposition on the target does not represent a problem, since the target and the redeposited atoms are the same material. But in reactive sputtering, the deposited film is a compound, and therefore a different material to the target. For example, aluminium oxide, a ceramic, has properties which are quite different from metallic aluminium. If the reactive film is an insulator, such as aluminum oxide, then the situation becomes intolerable.

When an insulator is deposited on the surface of the

* Corresponding author. Tel: +1 512 4622191; Fax: +1 512 24629411.

target, a capacitor is formed (see Fig. 1). The target acts as one conductor, the plasma acts as the other conductor, and the insulating film forms the dielectric of the capacitor. DC current cannot flow through a capacitor. This results in two problems. First, current flow is ion current, and therefore, if no argon ions strike the area, then no target atoms can be freed and no sputtering can occur. Consequently, this area of the target is poisoned. Second, the parasitic capacitor may not have enough dielectric capability to charge all the way up to the applied voltage. If not, the breakdown of the insulator will cause a sudden release of charge carriers, forcing the local current density to increase into the arc discharge region, which results in arcing with all its attendant particulate problems.

Asymmetric bipolar pulsed DC is the optimum solution to the target poisoning problem because it sets up conditions which cause the insulators on the target to be sputtered first and with a higher sputter yield than the base material (a mechanism called preferential sputtering). This eliminates target poisoning by removing the cause.

3. Preferential sputtering

Preferential sputtering is accomplished by adding a reverse voltage bias pulse to the normal DC waveform (see Fig. 2). First, if typical sputtering runs at about

-400 V, then the conditions are as shown. Argon ions accelerate towards the target at -400 V, striking the target and sputtering the aluminum. However, the redeposited insulating film on the target behaves in a very different manner. As the film forms, it tends to collect low-energy ions on its surface, charging the parasitic capacitor towards the applied voltage. As capacitor voltage climbs, the available energy with which the ions can strike the insulator is decreased by the voltage on the capacitor, thus reducing the likelihood of the film being sputtered off. Even worse, as the charge builds up, the ions are actually repelled by the electrostatic repulsion of the Ar^+ ions and the positive capacitor voltage. Next, the polarity is rapidly reversed to about +100 V (see Fig. 3), causing the plasma-facing surface of the dielectric film (parasitic capacitor) to be charged up to the opposite polarity (-100 V). The magic occurs as the reverse pulse ends and the voltage returns to sputter mode (-400 V), as shown in Fig. 4. Since the plasma side of the parasitic capacitor is now charged to -100 V, when the target reaches -400 V the effective voltage on the plasma side of the parasitic cap is -500 V. Thus, the argon ions are drawn by electrostatic attraction to the insulators, and strike with extra energy (500 V versus 400 V), thereby sputtering the insulators off the target first, eliminating target poisoning.

The effectiveness of asymmetric bipolar pulsed DC is also dependent on pulse frequency. The charging pulses must occur frequently enough to prevent the build-up

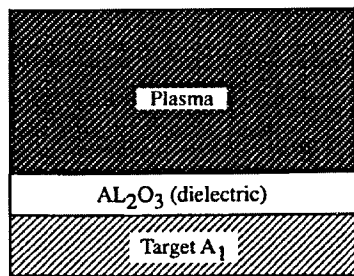

Fig. 1. Fundamental capacitor model.

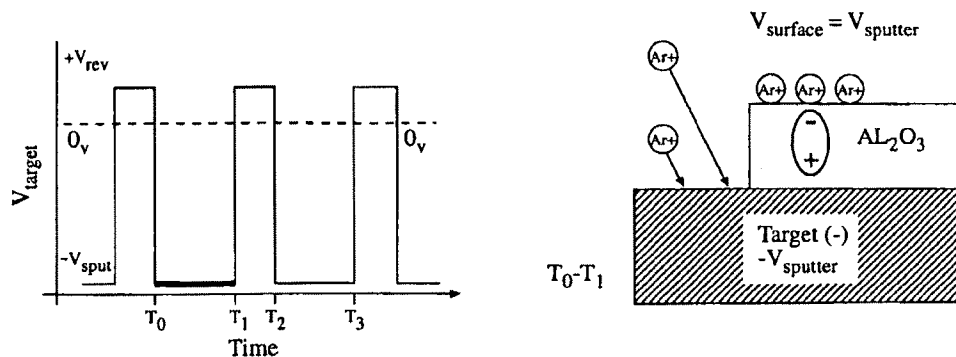
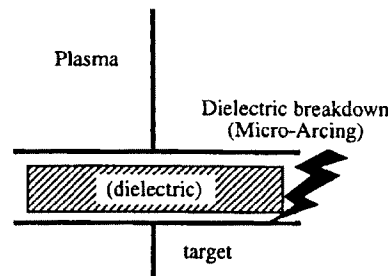

Fig. 2. Normal sputter mode.

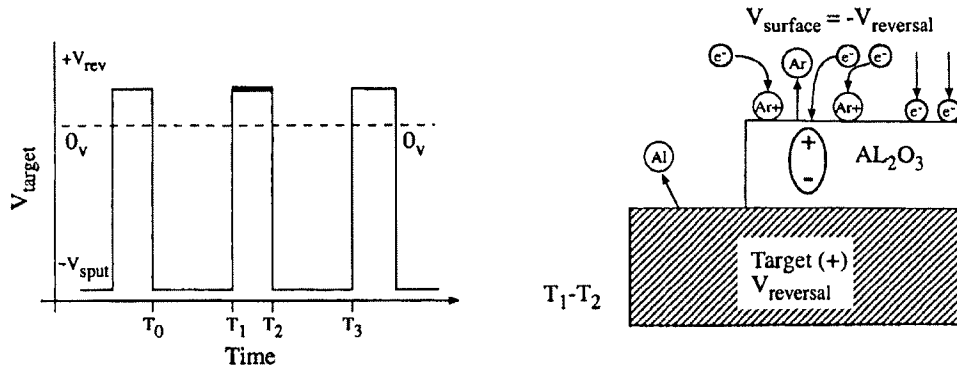

Fig. 3. Reversal mode.

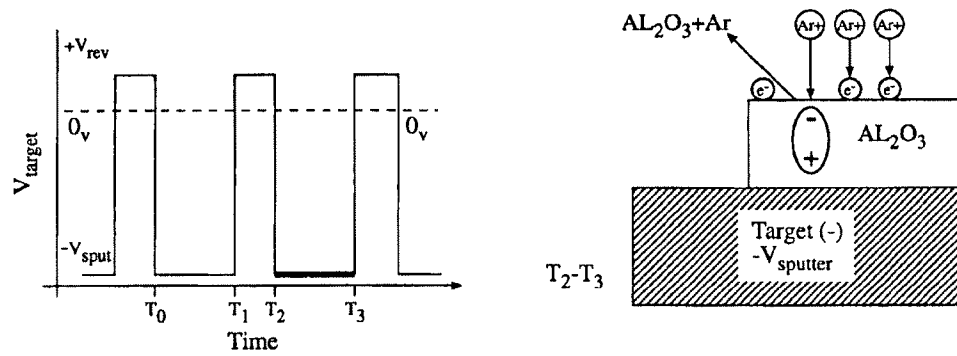

Fig. 4. Return to sputter mode.

of voltage on the parasitic capacitors from exceeding their breakdown [1]. Typical process frequencies are 80–150 kHz. As this technology has been applied to materials other than true insulators, it has become clear that preferential sputtering is also effective for resistive films. Slightly higher frequencies are needed due to the tendency of the resistive film to self-discharge. TaN, TiN and ITO seem to work best at around 150–180 kHz. The value of the reverse bias voltage is critical. It must be chosen to be low enough not to generate backsputtering, and yet high enough to maintain preferential sputtering. Experience on many different chambers has shown 75–100 V to be effective and safe. Full bipolar pulses have enough voltage to sputter in both directions. Clearly, if there is enough voltage to sputter one way, then there is enough to sputter in the other direction also. Most magnetrons are asymmetrical in their voltage withstand, and will tolerate up to about +150 V.

4. Deposition rate

It is equally critical to return to forward current (ion current) flow as quickly as possible after the reverse bias pulse in order to maximize the deposition rate. This drives the requirement for the forward sputter power to

be driven by a very stiff current source, giving a constant current regardless of the voltage required, and allowing the full forward current to be re-established immediately. These opposite drive requirements reflect the asymmetrical nature of the plasma itself (i.e. electron mass versus ion mass).

In actual use, asymmetric bipolar pulsed DC technology has demonstrated reactive deposition rates of 60–100% of the metallic deposition rate [3]. A typical example would be reactive TaN film (see Table 1). This is a much higher rate than any competitive technology. Bipolar dual cathode systems have difficulty approaching 50% due to the lost duty cycle in the transitions from positive to negative sputter voltage. Also, they require two magnetron target assemblies (see

Table 1
Rate and uniformity comparison (TaN)

Technique	Rate	Uniformity (%)
RF diode	1.06	2
RF magnetron	2.00	11.2
DC magnetron	3.53	Not long-term stable
Pulse DC magnetron	3.48	1.97

Fig. 5). Asymmetric bipolar pulsed DC technology was optimized to sputter insulators from a conductive target.

5. Uniformity enhancement

Asymmetric bipolar pulsed DC technology has proven to be particularly beneficial for the enhancement of film qualities. Film uniformity (deposition uniformity and film characteristics) has demonstrated benefits from the use of pulsed DC techniques. There are two mechanisms at work in these results. First, in the case of a complex film (the deposited film is a compound), the additional ionization of the pulsed plasma results in a hotter (greater electron temperature) and more chemically active plasma, which tends to improve the consistency of the film chemistry. This ionization enhancement comes from the high-frequency (edge rates) and the mid-frequency (pulse rate) components of the waveforms. The second mechanism is the effects of peak to average power ratio on the deposition pattern. The greater the power applied to a magnetron, the wider the erosion zone (race track). This occurs due to the opposing electrostatic and electromagnetic forces of the magnetron and the plasma ions. The magnetron has a preferred location for the ions to strike due to the geometry of the intersection of the electrical and magnetic fields. This "sweet spot" is located at the juncture of the peak magnetic and electrical fields, at the point where $E \times B$ is a maximum (see Fig. 6). At low power density the ions will simply form a narrow ring at this "sweet spot" radius, resulting in a very narrow erosion zone. As the power is increased, the ions begin to crowd together in the "sweet spot", but the electrostatic repulsion for the like-charged ions forces them to stay apart. Thus, the ions are forced into a widening pattern around the "sweet spot" radius (see Fig. 7). As the ions are forced apart, the additional energy required to generate ionization at the lower magnetic field intensity is compensated by an increase in plasma voltage. As the erosion zone (race track) becomes wider, the deposition pattern at the substrate also becomes more uniform. Another effect

ron and the plasma ions. The magnetron has a preferred location for the ions to strike due to the geometry of the intersection of the electrical and magnetic fields. This "sweet spot" is located at the juncture of the peak magnetic and electrical fields, at the point where $E \times B$ is a maximum (see Fig. 6). At low power density the ions will simply form a narrow ring at this "sweet spot" radius, resulting in a very narrow erosion zone. As the power is increased, the ions begin to crowd together in the "sweet spot", but the electrostatic repulsion for the like-charged ions forces them to stay apart. Thus, the ions are forced into a widening pattern around the "sweet spot" radius (see Fig. 7). As the ions are forced apart, the additional energy required to generate ionization at the lower magnetic field intensity is compensated by an increase in plasma voltage. As the erosion zone (race track) becomes wider, the deposition pattern at the substrate also becomes more uniform. Another effect

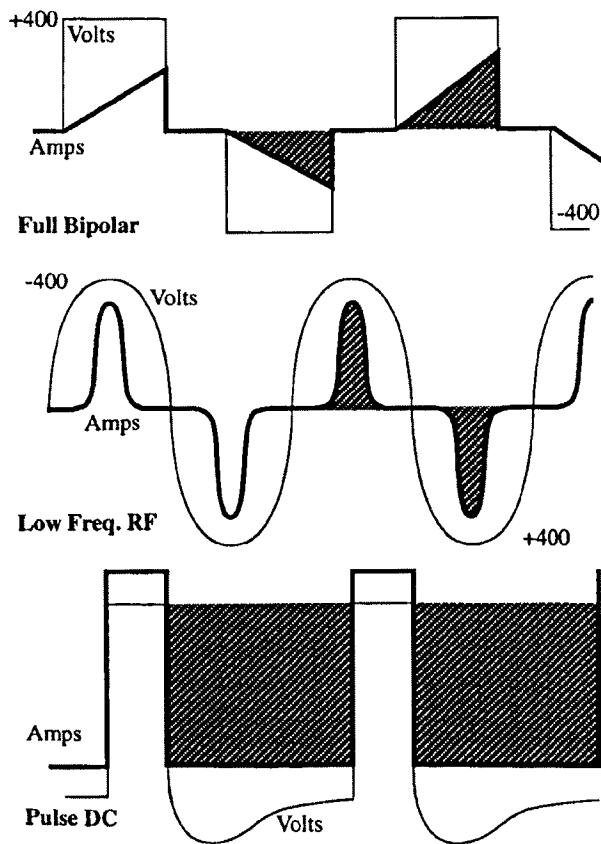

Fig. 5. Waveform comparison curves.

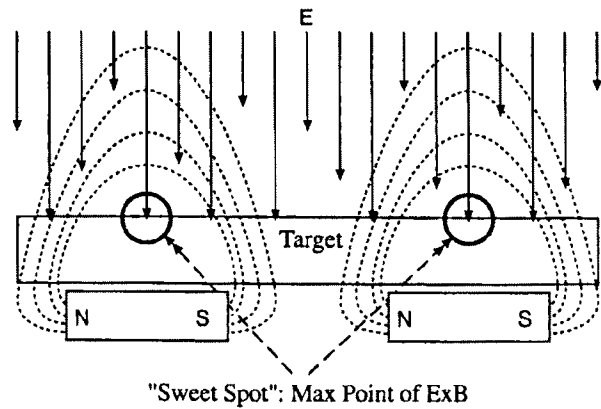

Fig. 6. "Sweet spot".

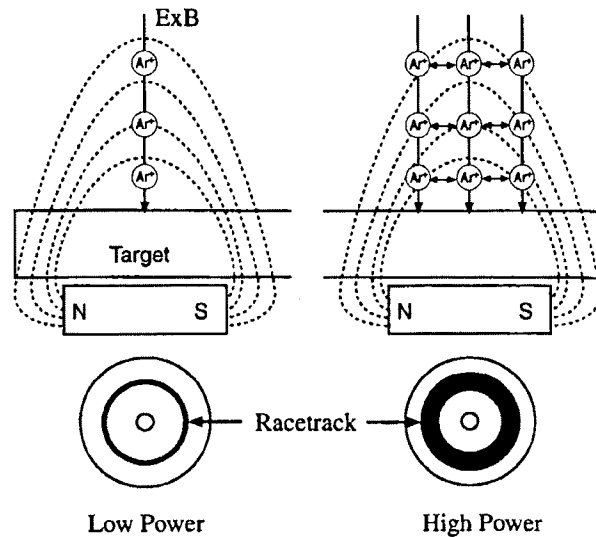

Fig. 7. Uniformity.

Table 2
Pulse DC etch results

Run	Substrate	Contaminant	Press (mT)	Frequency (kHz)	PW (μ s)	Power (W)	Approx. etch rate (nm s^{-1})
1	Silicon	Al_2O_3	30	162	1.32	192	0.02
2	Silicon	Al_2O_3	70	162	1.3	193	0.01
3	Silicon	Al_2O_3	46	185	1.2	308	0.056
4	Steel	Light oils	33	215	1.01	385	0.2
5	Steel	Heavy rust	39	215	1.01	413	0.2
6	Steel	Heavy rust	75	63	1.6	120	0.05

of the high power density ion crowding is an increase in the ionization of the sputtered material. This is caused by an increase in collisions between the freed target atoms and the incoming argon ions. As the density of freed target material and ions increases, the frequency of collisions between ions and molecules also increases. These effects are applicable to asymmetric bipolar pulsed DC simply due to the high peak to average power ratios attainable with the technology (see Fig. 8).

6. Other applications

6.1. Etching/cleaning

Just as it can remove insulating coatings from conductive sputter targets, asymmetric bipolar pulsed DC technology can remove non-conductive contamination from steel tools, silicon wafers and other conductive materials (see Table 2).

6.2. Bias/source

The AC characteristics of the technology also allow it to be applied to substrate bias of insulating CVD

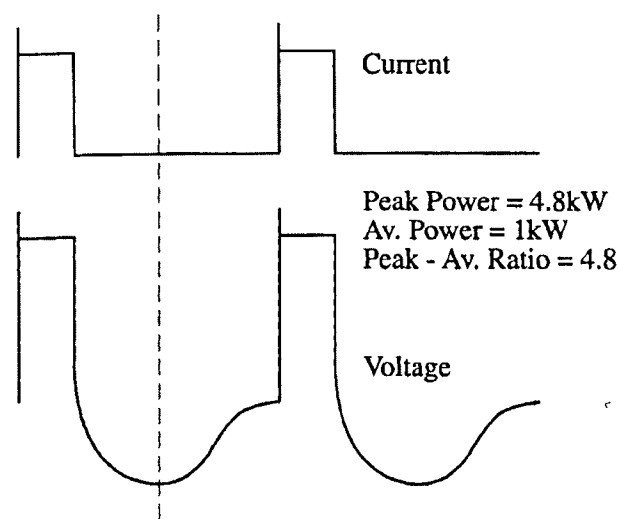

Fig. 8. Peak power.

processes. Work is presently in progress to harness the clear benefits of the technique, which include no RF, no RF match, direct DC-type control of the substrate bias energy and the rate improvements due to the increased bias duty factor. Several types of films, including DLC and B_4C , have shown benefit from asymmetric bipolar pulsed DC bias.

Additionally, the use of substrate bias can allow the elimination of some adhesion layers due to the enhancement of adhesion levels achieved by the use of high-energy bias during the growth of the sputtered films. The mechanisms of this adhesion enhancement are the dual effects of surface activation of the substrate through pre-etching and the additional energy available to the growing film from the substrate ion current. As the film begins to form, the early stages of formation are the most critical to the characteristics of the film, since the first layer will tend to set the form (crystallography) and adhesion for the entire film [2,4]. The addition of energy to this early film growth allows the atoms to achieve greater mobility and find the low-energy wells on the substrate surface where the adhesion will be maximized. Also, the high flux of energetic ions will tend to wash away any poorly adhered film atoms. These effects are also enhanced because of the increased ionization of the asymmetric bipolar pulsed DC. Strongly ionized film atoms can be implanted into the substrate due to the bias energy adding to the energy of the film atoms. Clearly, there is never a “free lunch”, so the negative effect of using high-energy bias is a reduction in the overall deposition rate due to the resputtering of the growing film. The use of bias to generate crystalline films at low substrate temperatures is also progressing well.

7. Conclusion

Asymmetric bipolar pulsed DC technology is the future of DC plasma processing because of its ability to extend the range of DC processes and to broaden the use of sputtered film applications into entirely new markets.

Explore Litigation Insights

Docket Alarm provides insights to develop a more informed litigation strategy and the peace of mind of knowing you're on top of things.

Real-Time Litigation Alerts



Keep your litigation team up-to-date with **real-time alerts** and advanced team management tools built for the enterprise, all while greatly reducing PACER spend.

Our comprehensive service means we can handle Federal, State, and Administrative courts across the country.

Advanced Docket Research



With over 230 million records, Docket Alarm's cloud-native docket research platform finds what other services can't. Coverage includes Federal, State, plus PTAB, TTAB, ITC and NLRB decisions, all in one place.

Identify arguments that have been successful in the past with full text, pinpoint searching. Link to case law cited within any court document via Fastcase.

Analytics At Your Fingertips



Learn what happened the last time a particular judge, opposing counsel or company faced cases similar to yours.

Advanced out-of-the-box PTAB and TTAB analytics are always at your fingertips.

API

Docket Alarm offers a powerful API (application programming interface) to developers that want to integrate case filings into their apps.

LAW FIRMS

Build custom dashboards for your attorneys and clients with live data direct from the court.

Automate many repetitive legal tasks like conflict checks, document management, and marketing.

FINANCIAL INSTITUTIONS

Litigation and bankruptcy checks for companies and debtors.

E-DISCOVERY AND LEGAL VENDORS

Sync your system to PACER to automate legal marketing.