

Transactions of the Institute of Measurement and Control

<http://tim.sagepub.com/>

Integrated microprocessor control of a hybrid i.c. engine/battery-electric automotive power train

P.W. Masding and J.R. Bumby

Transactions of the Institute of Measurement and Control 1990 12: 128

DOI: 10.1177/014233129001200303

The online version of this article can be found at:

<http://tim.sagepub.com/content/12/3/128>

Published by:



<http://www.sagepublications.com>

On behalf of:



Institute of Measurement and Control

[The Institute of Measurement and Control](http://www.imc.ac.uk)

Additional services and information for *Transactions of the Institute of Measurement and Control* can be found at:

Email Alerts: <http://tim.sagepub.com/cgi/alerts>

Subscriptions: <http://tim.sagepub.com/subscriptions>

Reprints: <http://www.sagepub.com/journalsReprints.nav>

Permissions: <http://www.sagepub.com/journalsPermissions.nav>

Citations: <http://tim.sagepub.com/content/12/3/128.refs.html>

>> [Version of Record](#) - Jan 1, 1990

[What is This?](#)

Integrated microprocessor control of a hybrid i.c. engine/battery-electric automotive power train

by P.W. Masding, BSc, PhD and J.R. Bumby, BSc, PhD, CEng, MIEE

This paper describes the development of a fully integrated microprocessor control system for a hybrid i.c.-engine/battery-electric automotive power train. Torque control systems for the internal-combustion engine and the electric-traction motor are designed using digital transfer functions and indirect methods of torque measurement. Root-locus methods are used in all designs to provide fast, critically damped closed-loop response. In all cases simple proportional-plus-integral control proved sufficient to achieve this. An overall cycle speed controller allows the laboratory test system to be exercised over any test driving cycle and offers the ability to carry out sophisticated power sharing and transmission shifting strategies.

Keywords: Hybrid vehicles, automotive power train control, microprocessor control, electric vehicles, i.c.-engines

Symbols

a	Zero of $g_c(w')$
f_c	Counter value from flywheel speed probe
f_t	Number of teeth on the flywheel speed probe gear
g	Gain of $g_c(w')$
$g_c(w')$	P+I Controller in w' -plane form
$g_c(z)$	Bilinear discretisation of $g_c(w')$
i_a	Armature current, A
i_f	Field current, A
J	Flywheel inertia, kg m^2
K	Constant relating dynamometer speed to load
K_c	Flywheel count to road speed conversion factor
k_i	$gaT_s/2$
M_{eq}	Equivalent vehicle mass, kg
N	Speed, rev/min
p_m	Inlet manifold depression, mbar
r_f	Final drive ratio
r_w	Vehicle wheel radius, m
T_{em}	Motor torque, Nm
T_f	Torque in gearbox output shaft, Nm
T_{ic}	Engine torque, Nm
t_r	Controller design criteria, rise time, s
T_s	Control system base sampling period (20 ms)

θ	Engine throttle position, 0.9° steps
θ_d	Demand throttle position, 0.9° steps
θ_m	Motor accelerator demand
ξ	Controller design criteria damping factor
σ	Real part of closed-loop pole
w_d	Damped frequency, rad/s

1. Introduction

In this paper some of the control problems encountered in designing and operating a 'drive-by-wire' hybrid internal-combustion (i.c.) engine/battery-electric vehicle are examined. With two power sources in the drive train, considerable flexibility in design and control of the complete system is possible. Various drive train arrangements have been investigated in previous computer-aided-design studies (Willis and Radtke, 1985; Burke and Somuah, 1980) but most have favoured the parallel hybrid arrangement illustrated by Fig 1. This mechanical configuration consists of an i.c.-engine and an electric traction motor connected mechanically in parallel so that both power sources are capable of driving the road wheels directly. The advantages of such a hybrid drive system stem from its versatility in being able to operate in pure electric mode in urban areas yet retaining an i.c.-engine for high-speed operation and long-range capability. By correct design, such a drive arrangement not only has the potential to reduce exhaust emissions in the urban environment substantially, but also of substituting up to 70% of the petroleum fuel used by the average road user (Forster and Bumby, 1988; Sandberg, 1980). Precisely how much petroleum substitution is achieved depends on the individual vehicle use pattern.

To realise the full potential of the hybrid drive, integrated control of both the prime movers and the common transmission is required. The problems associated with the development of such an integrated control system can be divided into two parts: mode selection; and component control. Mode selection is concerned with deciding whether the vehicle should run in an electric mode, an i.c.-engine mode or whether the i.c.-engine and the electric motor should provide propulsion torque together. Selecting which of the many possible operational modes to use under given operating conditions is a complex problem and interacts strongly with the basic design of the hybrid power train. An optimisation study of these problems based on a computer simulation of different hybrid-vehicle

School of Engineering and Applied Science, University of Durham, South Road, Durham DH1 3LE, England

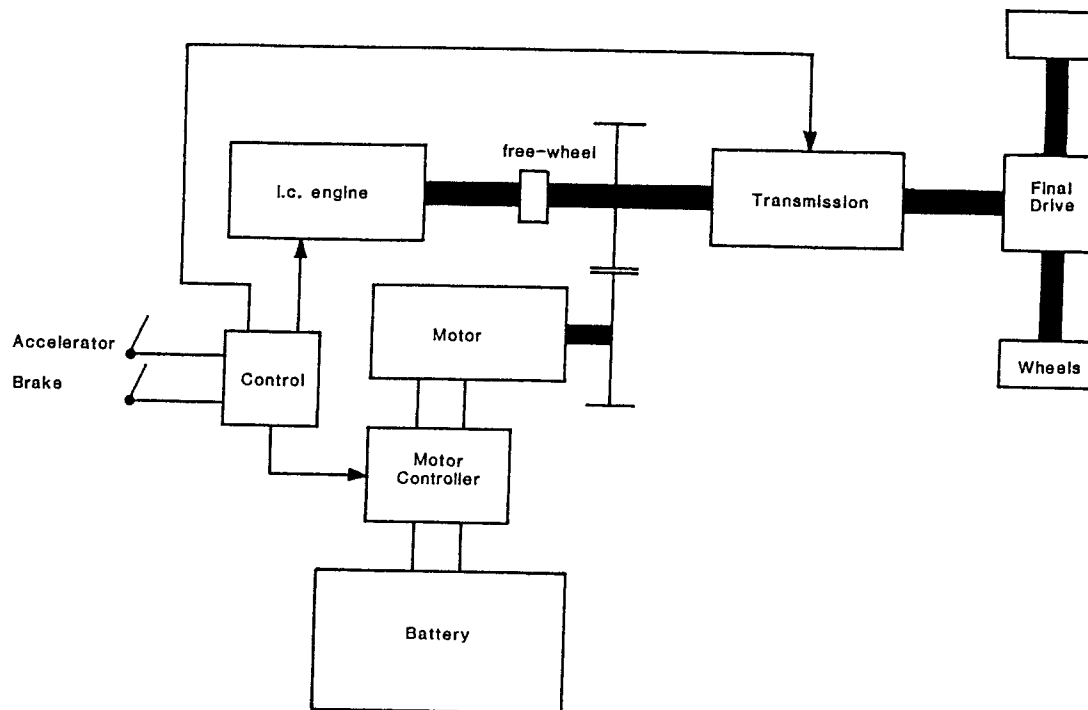

Fig 1 Parallel hybrid electric vehicle drive train

power-train configurations, component ratings and control strategies is discussed in some detail in Bumby and Forster (1987). The end result of the optimisation process is a mode controller which receives, as input, the driver's brake and accelerator signals and then adjusts the torque demand to the engine and motor to meet the total demand. In addition, it controls the gearbox, since selection of the correct gear ratio, to define engine/motor speed, has a critical effect on their efficiencies.

Once the mode controller has decided on a gear ratio and torque demand to be met by each of the prime movers, it is necessary then to design individual components controllers which operate the engine, motor and gearbox so that they meet the appropriate demand as quickly as possible and, when necessary, also allow smooth transition between modes. Earlier work has examined the control problems relating to automation of discrete ratio transmission units (Masding *et al.*, 1988). Conventional discrete ratio transmissions are ideal for this purpose since they offer the highest efficiency of any transmission system, and for this reason automation of such transmissions is attracting considerable attention (Main *et al.*, 1987; Busca *et al.*, 1979).

In this paper the additional component control problems relating to engine and motor torque control and smooth engine starting are addressed. One earlier system which tackled these problems was built in the USA by The General Electric Co. during the Electric and Hybrid Vehicle initiative and resulted in a microprocessor-controlled prototype hybrid car (Trummel and Burke, 1983; Somuah *et al.*, 1983). On the basis of preliminary design studies, this vehicle used an i.c.-engine and an electric traction motor connected mechanically in parallel. Control of the electric traction system was achieved by a chopper in the field

circuit and series/parallel battery switching to vary the armature voltage. Starting resistances and clutch slip were thus necessary to move the vehicle from rest. In the present work, power electronic armature and field choppers are used to give smooth, efficient motor performance over the whole operating range and to remove the need for a clutch system. This same electric drive system has been successfully used in an operational all-electric van produced by Lucas Chloride and Bedford (Manghan and Edwards, 1983). Bose *et al.* (1984) describe the control methods adopted in the HTV-1 but concentrate solely on transfer functions developed in the s -domain. In contrast, the control systems for the engine and motor presented in this paper make extensive use of digital models which have been previously developed to describe their dynamic characteristics (Masding and Bumby, 1990a; 1990b).

Satisfactory performance of the completed controllers is confirmed by using an extensive laboratory test facility. The test facility is a full-scale version of a parallel hybrid drive train using a 35 kW i.c.-engine and a 32 kW D.C. traction motor as prime movers. Both the engine and motor are coupled to a 4-speed synchromesh gearbox via a toothed drive belt. To the rear of the gearbox a flywheel-and-dynamometer combination provide a simulation of the loadings due to vehicle inertia and aerodynamic/tyre drag, respectively. Control of the laboratory system is carried out by an M68000 microprocessor system which is responsible for receiving data from the extensive range of transducers round the rig and responding with appropriate control signals to the throttle servosystem, power electronics and gearbox. This system allows the control algorithms developed in this paper to be fully tested under operational conditions as well as in simulation. A complete description of the test bed facility is given in Bumby and Masding (1988).

TABLE 1: Possible operating modes for the parallel hybrid vehicle

Mode	Description
Electric mode	All propulsion power supplied by the electric traction system
I.C.-engine mode	All propulsion power supplied by the i.c.-engine
Primary electric mode	The electric traction system provides the principle torque, but when necessary its maximum torque is augmented by the engine
Primary i.c.-engine mode	The i.c.-engine provides the principal torque, but when necessary its maximum torque is augmented by the motor
Hybrid mode	Both the i.c.-engine and the electric traction system provide torque split between them in some way
Battery charge mode	The i.c.-engine provides both the propulsion power and power to charge the batteries, with the traction motor acting as a generator
Regenerative braking	During braking the vehicle kinetic energy is returned to the battery with the traction motor acting as a generator
Accelerator 'kick-down'	Essentially a primary i.c.-engine mode when full engine torque is allowed to give maximum acceleration

2. Hybrid-vehicle control modes

The different operating modes available with a hybrid drive system are summarised in Table 1. In general, the electric mode can be used in urban areas, for short journeys and when the engine load would be small giving rise to low engine efficiency. It is always used for moving the vehicle away from rest, since a conventional clutch system is not included. When the drive-train speed exceeds 1000 rev/min, the engine can be started and synchronised with the moving drive train to provide additional power if required. Such operation is possible owing to a free-wheel unit in the engine drive line which allows the engine to remain stationary when the rest of the drive train is in motion. Primary i.c.-engine mode is used when vehicle speed and loading are both high, which gives high engine efficiency. When necessary, the engine torque can be augmented by the motor for rapid acceleration or hill climbing. Typically, the motor will be used to provide extra power if the engine output would otherwise exceed 90% of maximum, since this leads to inefficiency. Over journeys with an exceptionally large amount of acceleration or hill climbing, the battery state of charge may become very low, but this can not be allowed to continue until the batteries are completely depleted, since the vehicle would then be unable to move away from rest. To counter this problem, a negative torque may be scheduled from the motor so that the engine both drives the wheels and charges the traction batteries. As discussed in Bumby and Forster (1987), this mode is necessary but has low overall efficiency and so should be avoided if at all possible.

The final two modes are the regenerative braking mode and the accelerator 'kick down' mode. The latter provides the driver with full power from both the engine and the traction motor and is intended mainly for use in emergency conditions when all economy considerations are overridden. Finally, regenerative braking is used whenever the vehicle is braked, in order to recover some of the kinetic energy of the vehicle and return it to the batteries. Having the motor connected to the drive train permanently means that regenerative braking is always immediately available.

All the above operating modes pose common control problems in that, after a particular mode has been chosen, it must be possible to schedule and control the torque output of both the engine and motor. In addition, to provide smooth transition between modes it is necessary to start and synchronise the engine with a moving drive train accurately. Torque scheduling is the responsibility of the overall vehicle-mode controller on the basis of a strategy arising from the optimisation study mentioned earlier; however, in this paper the secondary problem of individual component control to achieve the desired torques and to start the engine is addressed.

3. Controller design

Experience has shown that robust controllers suitable for all the applications in the hybrid vehicle can be produced using proportional-plus-integral control. Such controllers can give satisfactory performance not only for torque control of both prime movers but, in addition, for engine speed on no-load and overall speed control through a cycle. An advantage of these low-order controllers is their speed of execution: during a typical driving cycle the main computer takes only 3 ms to carry out cycle speed and prime-mover torque-control calculations. High speed and accurate computation is encouraged by the use of 32-bit integer arithmetic throughout. All controller design is carried out in the w' -plane using root-locus pole placement methods. Z-transfer functions are mapped into this plane by the transformation pair

$$w' = \frac{2}{T_s} \left(\frac{z-1}{z+1} \right) \quad \dots(1)$$

$$z = \frac{w' + 2/T_s}{w' - 2/T_s} \quad \dots(2)$$

where T_s is the sampling period. Owing to the similarity between the s and w -planes, the proportional-plus-integral controller retains its usual form:

$$g_c(w') = g \left(\frac{w' + a}{w'} \right) \quad \dots(3)$$

Acceptable closed-loop performance is defined in terms of the rise time, t_r , and the damping factor ξ . These are defined for a second-order system by the equations:

$$w' = \sigma \cdot jw_d \quad \dots(4)$$

$$w_d = \frac{\cos^{-1}(-\xi)}{t_r} \quad \dots(5)$$

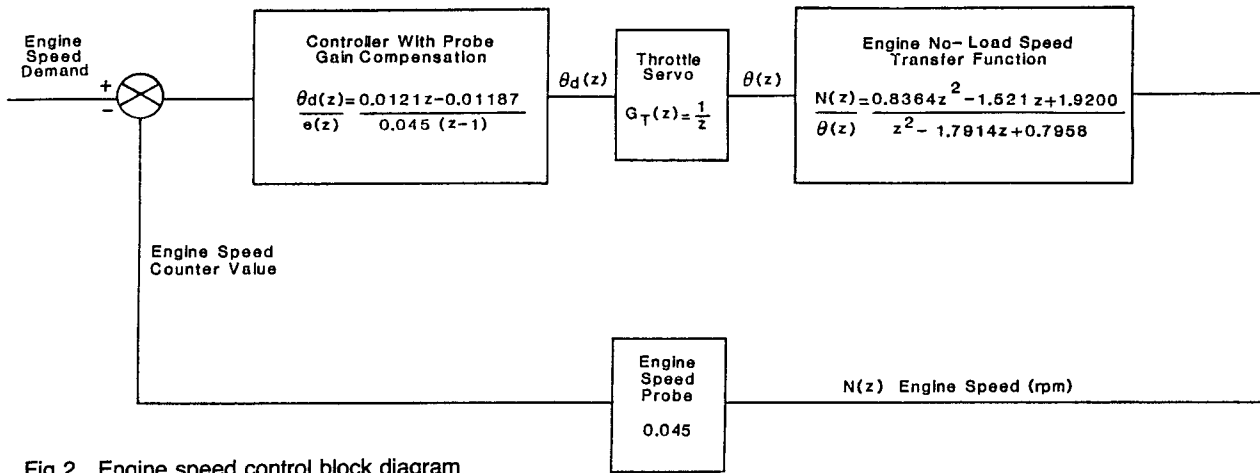

Fig 2 Engine speed control block diagram

$$\sigma = \frac{w_d}{\tan(\cos^{-1}(-\xi))} \quad \dots(6)$$

By choosing a suitable rise time for a specific controller and adopting $\xi = 0.707$ for critical damping in all cases, the position of the required closed-loop poles is defined. These pole locations can only be used as an initial guide, however, because in reality the plant does not produce a second-order closed-loop system. Fine tuning of the controller design is achieved by an iterative process. Eqn (3) can be transformed back into the z -plane by the reverse mapping of Eqn (1) to give

$$g_c(z) = \frac{(g + k_i)z + (k_i - g)}{z - 1} \quad \dots(7)$$

where $k_i = gaT_s/2$. From this equation comes the discrete direct realisation for the controller output u_k

$$u_k = u_{k-1} + (g + k_i)e_k + (k_i - g)e_{k-1} \quad \dots(8)$$

When referring to plant transfer functions for the control of both engine and motor torque, the coefficients that are quoted apply to the following general discrete transfer function

$$\frac{y(z)}{u(z)} = \frac{b_0 + b_1z^{-1} + \dots + b_mz^{-m}}{1 - a_1z^{-1} - \dots - a_nz^{-n}} \quad \dots(9)$$

4. Engine starting and speed synchronisation

Whenever the hybrid vehicle is operating in an all-electric mode or is stationary, the i.c.-engine will be uncoupled from the drive train by means of the one-way clutch. Since in either of these situations the engine is not required to provide torque, the most obvious strategy is to shut it down entirely in order to conserve petroleum fuel. Adopting this strategy means that the next time the engine is required it must be started and synchronised with the moving, and possibly accelerating, drive train, before it can replace or augment the torque supplied by the electric traction system. Consequently, a starting system is required which has fast response and no tendency to overshoot the prevailing drive-train speed, thus avoiding a shock torque in the drive shaft as the one-way clutch is engaged. Design of such a control system uses the transfer function relating throttle position to engine

speed identified in Masding and Bumby (1990a) and repeated as

$$\frac{\Delta N(z)}{\Delta \theta(z)} = \frac{0.838 - 1.510z^{-1} + 1.922z^{-2}}{1 - 1.790z^{-1} + 0.795z^{-2}} \quad \dots(10)$$

When this is connected to the required control algorithm and throttle servo-system, the block diagram of Fig 2 is produced.

For large changes in throttle demand – that is, greater than four steps per sample period – the throttle-position transfer function, $G_T(z)$, is non-linear as explained in Masding and Bumby (1990a). However, for design purposes, small variations in throttle demand are assumed when $G_T(z)$ reduces to $1/z$ producing a linear system which can be transformed to the w' plane for controller design. In order to produce an acceptably short synchronisation time for the engine, a system rise time of $t_r = 0.5$ s and critical damping are chosen as the design criteria. By Eqns (4)–(6) this suggests closed-loop poles $w' = 4.71 \pm j4.71$. Fig 3 shows the compensated system root locus with the controller

$$g_c(w') = 0.012 \left(\frac{w' + 1.1}{w'} \right) \quad \dots(11)$$

With this controller the presence of the closed-loop

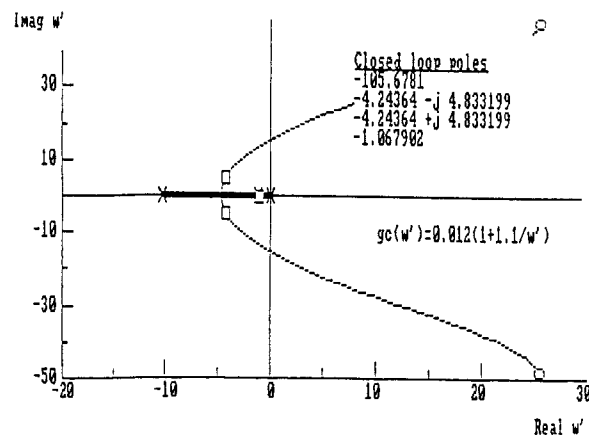

Fig 3 Compensated root locus for control of engine speed on no-load

Explore Litigation Insights

Docket Alarm provides insights to develop a more informed litigation strategy and the peace of mind of knowing you're on top of things.

Real-Time Litigation Alerts



Keep your litigation team up-to-date with **real-time alerts** and advanced team management tools built for the enterprise, all while greatly reducing PACER spend.

Our comprehensive service means we can handle Federal, State, and Administrative courts across the country.

Advanced Docket Research



With over 230 million records, Docket Alarm's cloud-native docket research platform finds what other services can't. Coverage includes Federal, State, plus PTAB, TTAB, ITC and NLRB decisions, all in one place.

Identify arguments that have been successful in the past with full text, pinpoint searching. Link to case law cited within any court document via Fastcase.

Analytics At Your Fingertips



Learn what happened the last time a particular judge, opposing counsel or company faced cases similar to yours.

Advanced out-of-the-box PTAB and TTAB analytics are always at your fingertips.

API

Docket Alarm offers a powerful API (application programming interface) to developers that want to integrate case filings into their apps.

LAW FIRMS

Build custom dashboards for your attorneys and clients with live data direct from the court.

Automate many repetitive legal tasks like conflict checks, document management, and marketing.

FINANCIAL INSTITUTIONS

Litigation and bankruptcy checks for companies and debtors.

E-DISCOVERY AND LEGAL VENDORS

Sync your system to PACER to automate legal marketing.