

IPR2014-00570

Introduction

- U.S. Patent No. 8,214,097
- Ground 6 (§ 103):
 - Challenged claims: 30, 31, 35, 36, 39
 - Asserted Art: Severinsky and Anderson
- Ground 7 (§ 103):
 - Challenged claim: 32
 - Asserted Art: Severinsky, Anderson, and Yamaguchi
- Ground 8 (§ 103):
 - Challenged claim: 33
 - Asserted Art: Severinsky, Anderson, Yamaguchi and Katsuno

Introduction to the '097 Patent

- The '097 Patent is directed to hybrid vehicles and control systems thereof.
- The '097 Patent describes a hybrid control strategy for:
 - limiting the rate of increase of the engine's output torque such that the combustion of fuel occurs at a substantially stoichiometric air-fuel ratio
 - and using the electric motor to meet any shortfall in torque required to operate the vehicle in response to the operator's command.
- The '097 Patent describes a hybrid control strategy that allows for starting the engine at a substantially stoichiometric air-fuel ratio.

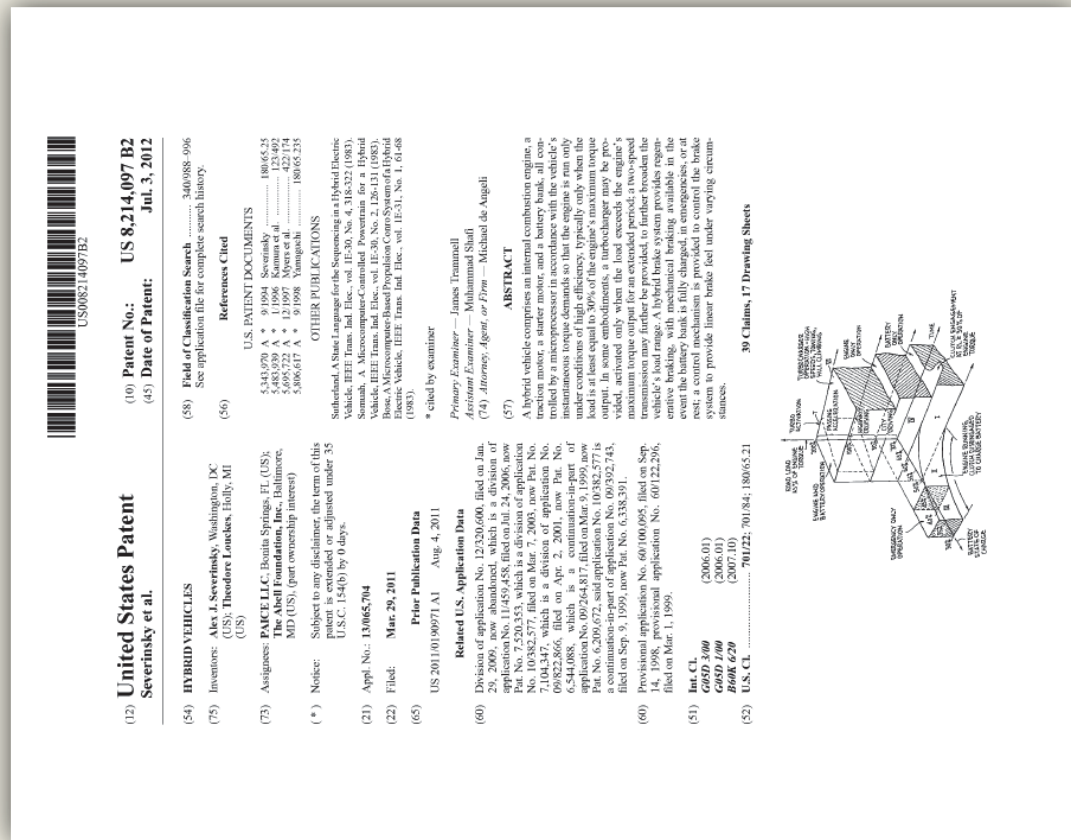

Introduction to the '097 Patent

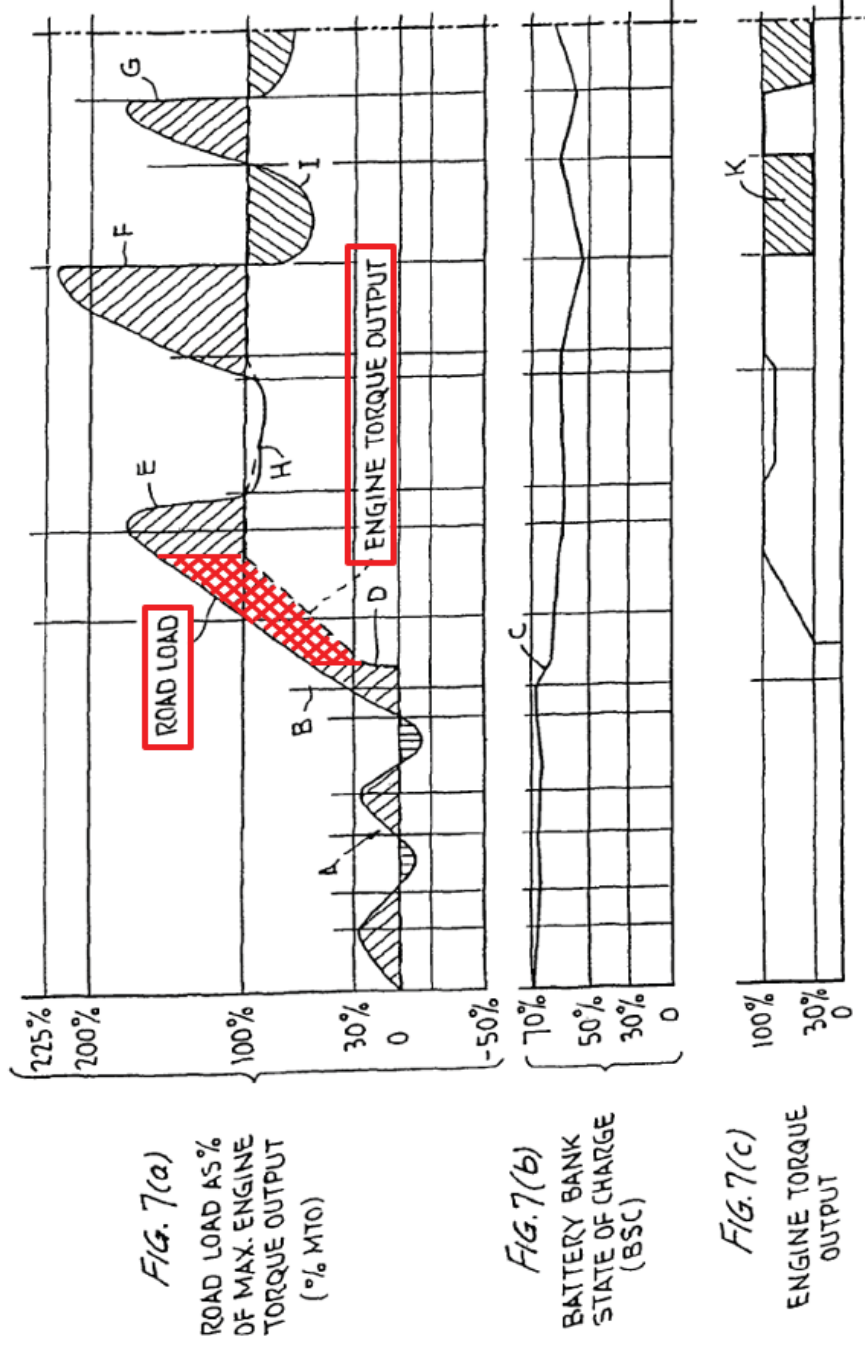

“The rate of change of the engine’s torque output is limited, e.g., to 2% or less per revolution, as indicated by noting that the dashed line in FIG. 7(a), indicating the instantaneous engine output torque, lags the solid line indicating the vehicle’s instantaneous torque requirement. Thus limiting the rate of change of engine output torque is preferred to limit undesirable emissions and improve fuel economy”

'097 Patent at 38:62-39:1

'097 Patent at Fig. 7.

Introduction to the '097 Patent

- As shown in Figure 7(a) starting at point D, the rate of increase of the engine's output torque is limited so as to maintain substantially stoichiometric combustion. '097 patent at 38:62-65; see also Ex. 2002 at ¶35.

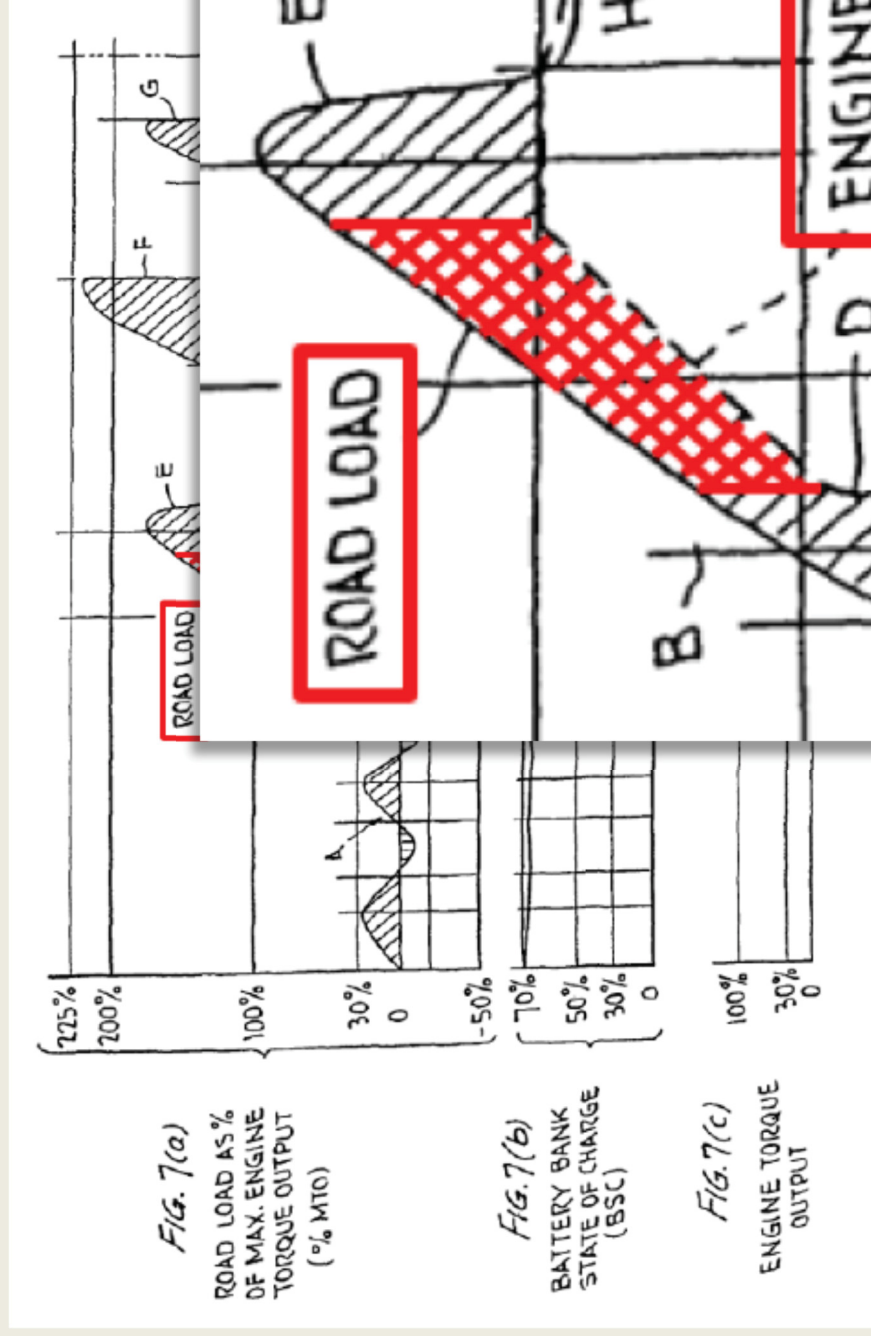

'097 Patent at Fig. 7.

Introduction to the '097 Patent

- When this occurs, the engine's output torque does not meet the road load, and the electric motor provides the balance of the torque to propel the vehicle (as shown by the red cross-hatched area). Ex. 2002 at ¶35.

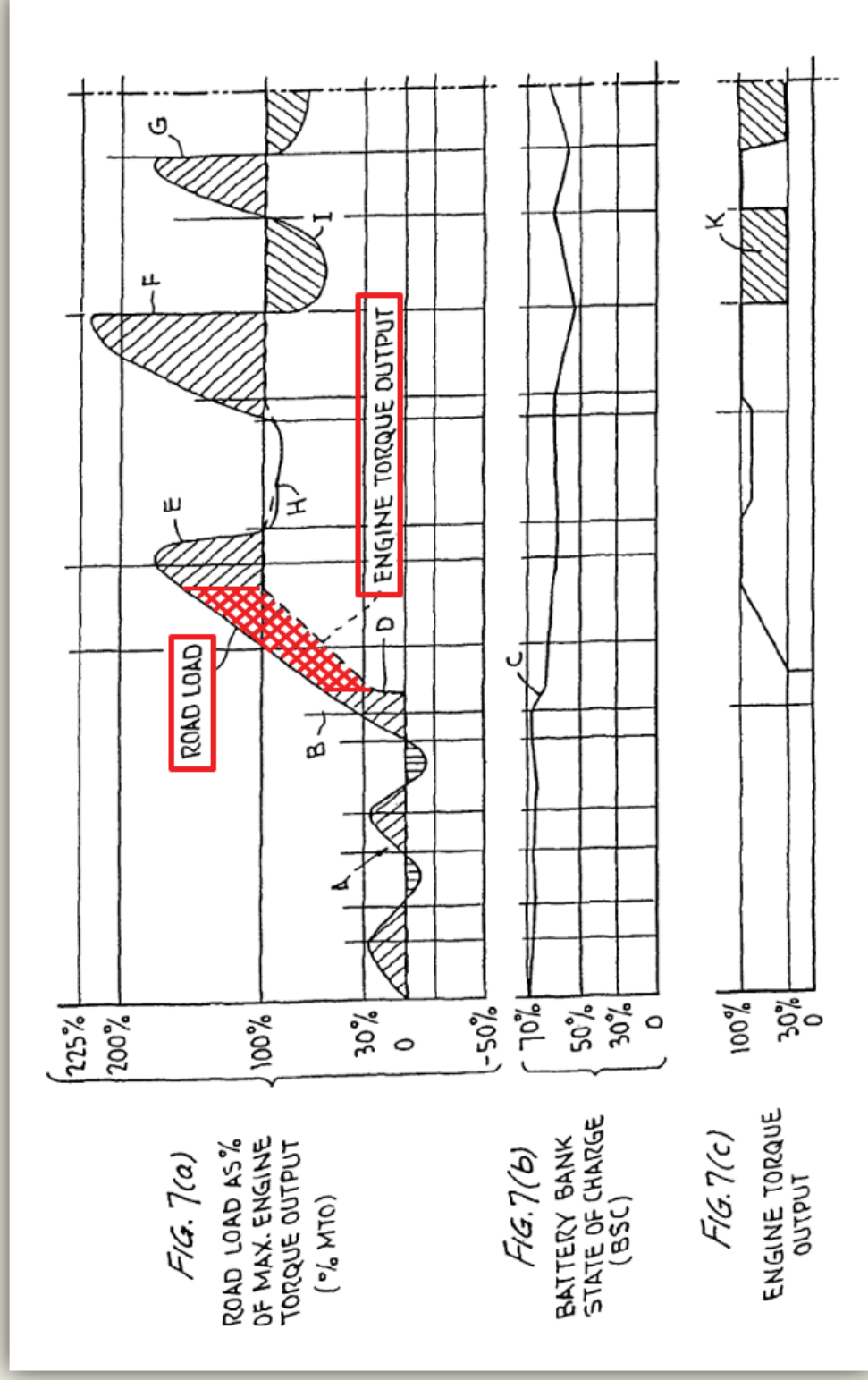

'097 Patent at Fig. 7.

'097 Patent Claim 30 Introduction

30. A hybrid vehicle, comprising:
an internal combustion engine operable to propel the hybrid vehicle by providing torque to the one or more wheels, wherein said engine has an inherent maximum rate of increase of output torque;
at least one electric motor operable to propel the hybrid vehicle by providing torque to the one or more wheels; a battery coupled to the at least one electric motor, operable to provide electrical power to the at least one electric motor; and
a controller, operable to control the flow of electrical and mechanical power between the engine, the at least one electric motor, and the one or more wheels, responsive to an operator command;
wherein said controller controls said at least one electric motor to provide additional torque when the amount of torque being provided by said engine is less than the amount of torque required to operate the vehicle; and
wherein said controller controls said engine such that a rate of increase of output torque of said engine is limited to less than said inherent maximum rate of increase of output torque, and wherein the controller is operable to limit the rate of change of torque produced by the engine such that combustion of fuel within the engine occurs at a substantially stoichiometric ratio.

Claim 30 requires that the controller limit the rate of increase of output torque of the engine to less than the inherent maximum rate of increasing of output torque resulting in substantially stoichiometric fuel combustion

'097 Patent, Claim 30.

Introduction to the Prior Art

- Severinsky (Ex. 1009) shares a common inventor with the '097 Patent.
- Directed to a parallel hybrid architecture.
- Discloses three primary modes:
 - Motor only (“low speed”)
 - Engine only (“highway cruising”)
 - Motor + Engine (“high-speed acceleration and/or hill climbing”)



US005343970A
United States Patent [19] **5,343,970**
Severinsky [45] **Date of Patent:** **Sep. 6, 1994**

[54] **HYBRID ELECTRIC VEHICLE**
 [76] **Inventor:** Alex J. Severinsky, 10904 Pobbie Run, Silver Spring, Md. 20902
 [21] **Filed:** Sep. 21, 1992
 [53] **Int. Cl.:** B60K 6/04
 [58] **Field of Search:** 180/65.2; 180/65.6; 180/65.6; 180/65.7; 65.3; 65.4; 180/65.6; 165; 60/716, 718, 4737A, 3, 8, 9

References Cited
 U.S. PATENT DOCUMENTS
 3,525,874 8/1970 Toy 180/65.2
 3,585,317 3/1973 Yaman et al. 180/65.2
 3,732,751 5/1973 Brennan et al. 180/65.2
 3,791,475 2/1974 Rosen 180/65.2
 3,854,472 4/1975 Duan 180/65.4
 3,923,115 12/1975 Halling 180/65.2
 4,062,056 8/1978 Horvinski 180/65.2
 4,148,192 4/1979 Cummings 180/65.2
 4,180,138 12/1979 Shea 180/65.2
 4,205,254 12/1981 Monson et al. 180/65.2
 4,313,080 1/1982 Park 180/65.2
 4,331,405 9/1982 Felde et al. 180/65.2
 4,354,144 10/1982 McCarthy 180/65.4
 4,405,029 9/1983 Hunt 180/65.2
 4,407,132 10/1983 Kawakasa et al. 180/65.4
 4,438,542 3/1984 Kenyon 180/65.2
 4,470,476 9/1984 Hunt 180/65.2
 4,533,011 8/1985 Heideneyer et al. 180/65.2
 4,578,855 4/1986 Melian 180/65.4

OTHER PUBLICATIONS
 SAE Technical Paper Series 891659, Bullock, Jr., SAE Technical Paper Series 910247, Kalberlah, pp. 69-78, Feb. 25-Mar. 1, 1991.
Prinzip Examiner—Margaret A. Focartino
Assistant Examiner—Peter C. English

ABSTRACT
 An improved hybrid electric vehicle includes an internal combustion engine and an electric motor. Both the motor and the engine provide torque to drive the vehicle directly through a controllable torque transfer unit. Typically at low speeds or in traffic, the electric motor provides the torque to drive the vehicle. The electric motor under acceleration and during hill climbing both the engine and the motor provide torque to drive the vehicle and in steady state highway cruising, the internal combustion engine alone drives the vehicle. The internal combustion engine provides the torque to drive the vehicle at maximum fuel efficiency during highway cruising. The motor is operable as a generator to charge the batteries as needed and also for regenerative braking. No transmission is employed. The motor operates at substantially constant speed and has a rated power at least equal to that of the internal combustion engine. In this manner a cost efficient vehicle is provided, suffering no performance disadvantage compared to conventional vehicles.

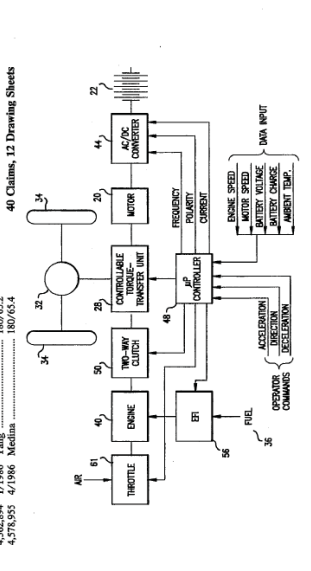

40 Claims, 12 Drawing Sheets
 Page 1 of 27
 FMC 1009

Introduction to Anderson

- Anderson (Ex. 1006) is directed to a discussion of how engine [APU] characteristics affect the design of a hybrid strategy
- While Anderson considers both parallel and series vehicles, Anderson's emissions-related strategy is explicitly limited to series architectures.

Downloaded from SAE International by John Bradford, Friday, December 06, 2013 06:15:49 PM

SAE TECHNICAL
PAPER SERIES

950493

The Effects of APU Characteristics on the Design of Hybrid Control Strategies for Hybrid Electric Vehicles

Catherine Anderson and Erin Pettit
AeroVironment

Reprinted from: Design Innovations in
Electric and Hybrid Electric Vehicles
(SP-1089)

SAE The Engineering Society
For Advancing Mobility
Land Sea Air and Space
INTERNATIONAL

400 Commonwealth Drive, Warrendale, PA 15096-0001 U.S.A. Tel: (412) 776-4841 Fax: (412) 776-5760

International Congress and Exposition
Detroit, Michigan
February 27 - March 2, 1995

Page 1 of 9

FMC 1006

**Ground 6 - Severinsky and Anderson Do Not Disclose
or Render Obvious Claims 30, 31, 35, 36, 39
of the '097 Patent**

Ground 6: No motivation to combine Severinsky and Anderson

Ford's proposed combination

30. A hybrid vehicle, comprising:
an internal combustion engine operable to propel the hybrid vehicle by providing torque to the one or more wheels, wherein said engine has an inherent maximum rate of increase of output torque;
at least one electric motor operable to propel the hybrid vehicle by providing torque to the one or more wheels; a battery coupled to the at least one electric motor, operable to provide electrical power to the at least one electric motor; and
a controller, operable to control the flow of electrical and mechanical power between the engine, the at least one electric motor, and the one or more wheels, responsive to an operator command;
wherein said controller controls said at least one electric motor to provide additional torque when the amount of torque being provided by said engine is less than the amount of torque required to operate the vehicle; and
wherein said controller controls said engine such that a rate of increase of output torque of said engine is limited to less than said inherent maximum rate of increase of output torque, and wherein the controller is operable to limit the rate of change of torque produced by the engine such that combustion of fuel within the engine occurs at a substantially stoichiometric ratio.

**Allegedly Satisfied
by Severinsky**

**Allegedly Satisfied
by Anderson**

Severinsky and Anderson cannot be combined in the manner asserted by Ford

Parallel

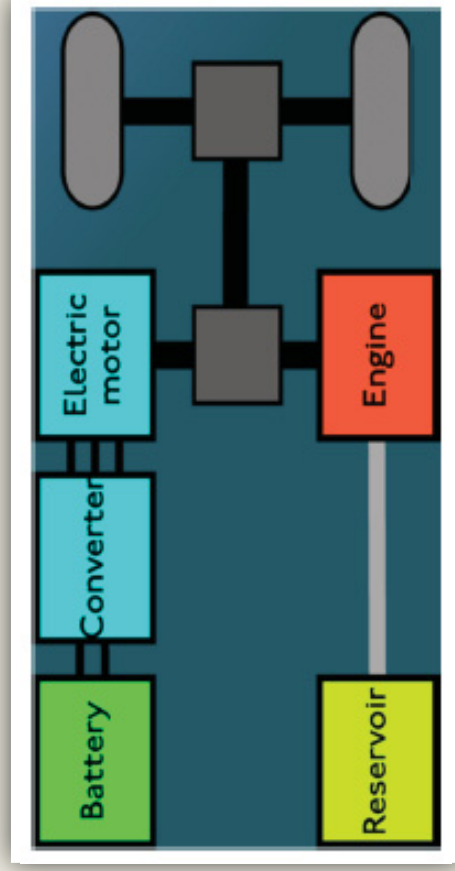

Series

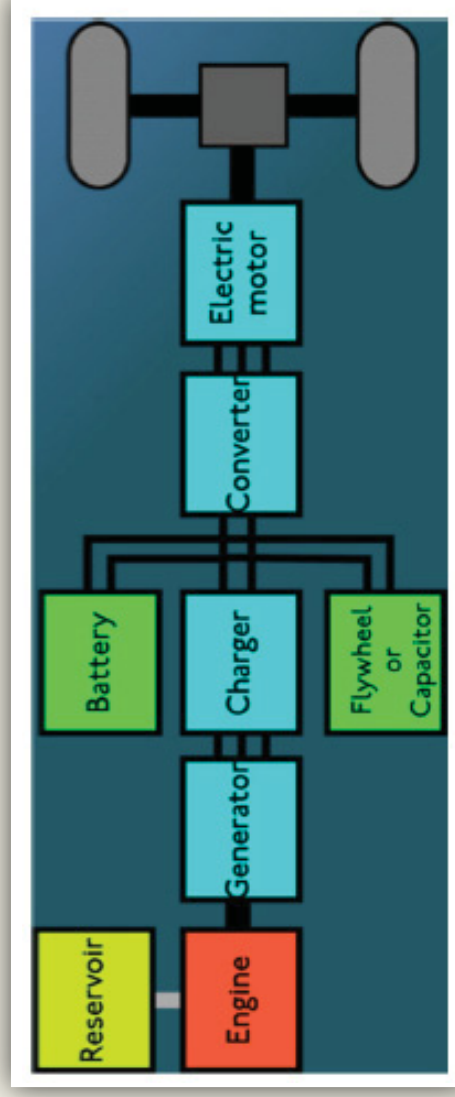

Severinsky and Anderson cannot be combined in the manner asserted by Ford

Parallel

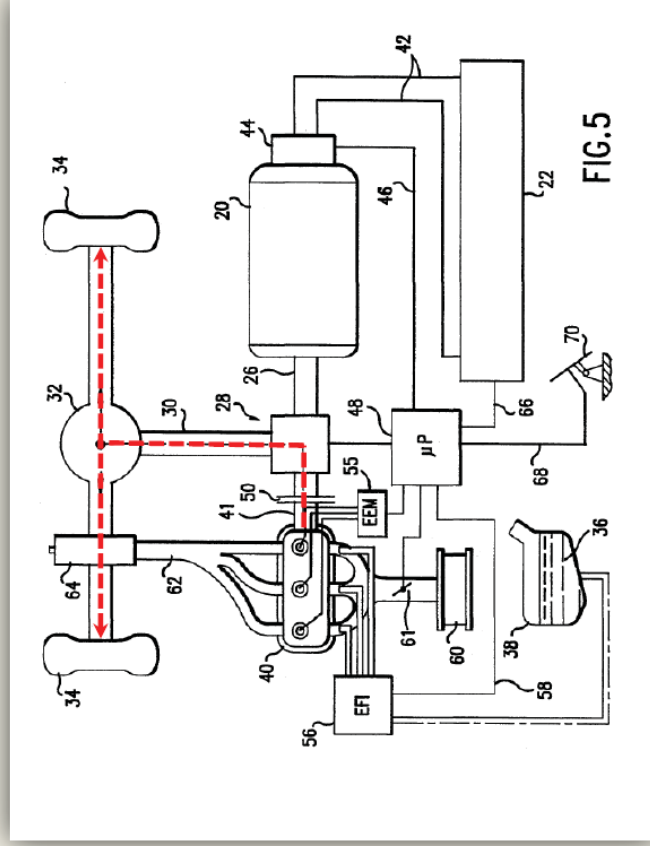

Severinsky, Ex. 1009 at Fig. 5; Ex. 2002 at ¶ 55.

Series

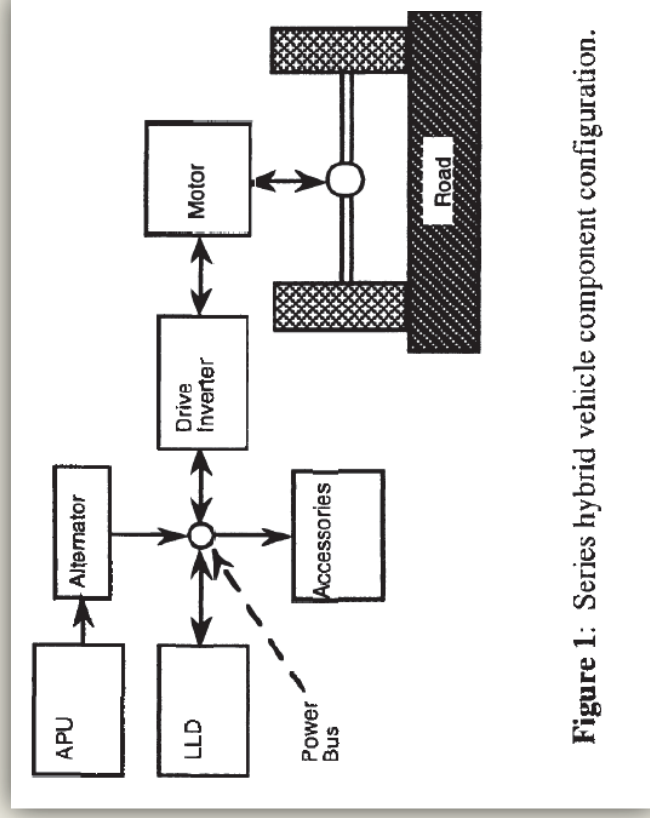

Figure 1: Series hybrid vehicle component configuration.

Anderson, Ex. 1006 at Fig. 1; Ex. 2002 at ¶ 59.

Severinsky and Anderson cannot be combined in the manner asserted by Ford

- Anderson is focused on the design of a strategy for a power assist hybrid, which is a series hybrid system. Ex. 2002 at ¶¶70, 80.
- In a series system, the engine is not connected to the drive train. Instead, the engine generates electric power, which is then used by a motor that is connected to the drive train. *Id.* at ¶48, 83.
- Thus, the engine is not required to respond to changing operator commands (and in fact cannot). *Id.*
- Thus, the control of the engine is not time sensitive. *Id.*
- The engine can run at predefined constant power levels to charge the battery independent from operator commands. *Id.*

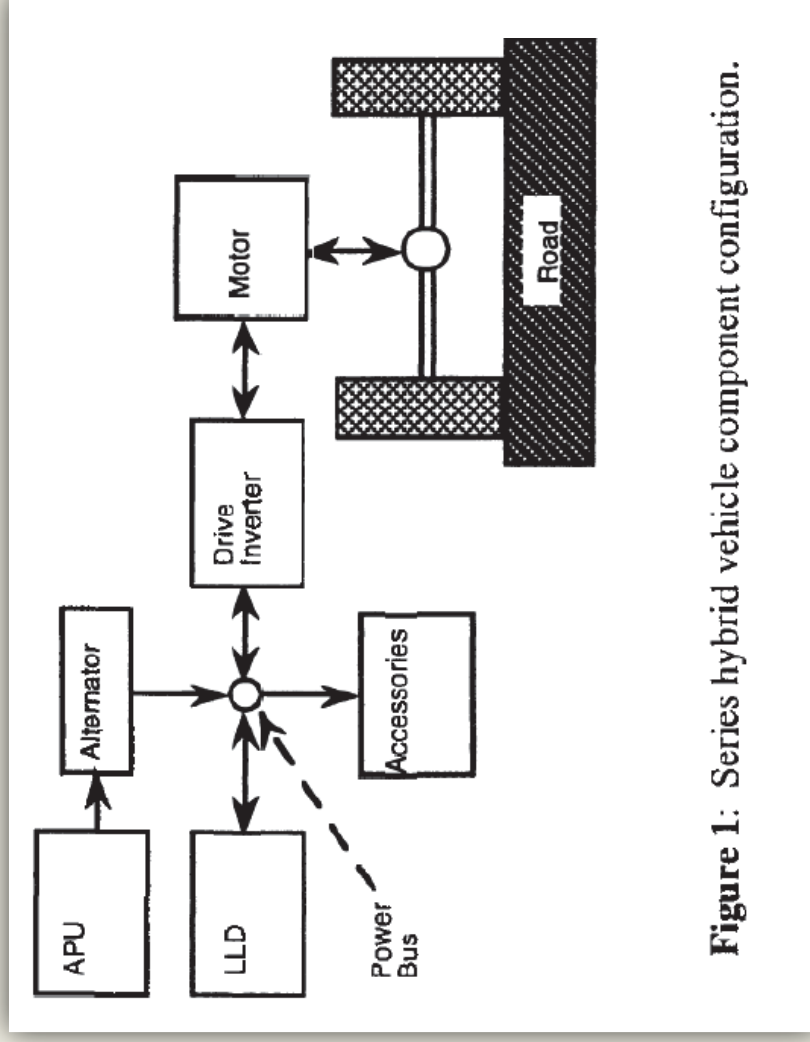

Figure 1: Series hybrid vehicle component configuration.

Anderson, Ex. 1006 at Fig. 1; Ex. 2002 at ¶ 55.

Severinsky and Anderson cannot be combined in the manner asserted by Ford

- Anderson's disclosure regarding emissions is directed to a series hybrid. Ex. 2002 at ¶¶ 66, 70-72.

Discussion of "hybrid strategy"

Emissions - Frequently, one of the principle aims of a hybrid vehicle is to reduce vehicle emissions to ULEV (Ultra Low Emission Vehicle) levels. Consequently, APU emissions are very important for system success. In general, emissions are minimized when a stoichiometric air to fuel ratio is maintained by a closed loop feedback system (using an oxygen sensor for feedback). In some operating regimes, such as engine starts and transients, the stoichiometric ratio is very difficult to maintain resulting in an increase in emissions.

During a cold-start, the engine must run rich to achieve sufficient vaporization of the fuel. Rich running results in high hydrocarbons (HC) and carbon monoxide (CO) emissions, but low nitrogen oxides (NOx) emissions. A hot-start has many of the same problems as a cold start, but the time duration before the engine and catalytic converter warm up is much shorter. A hybrid strategy which minimizes engine cycling will minimize start-related emissions, but that may require that the engine have a higher turn-down ratio.

Transients present an emissions problem that is largely related to the speed of the transient. The closed loop feedback system that maintains the stoichiometric air fuel ratio is sufficient during quasi-steady state modes, however, it can only react as fast as the O₂ levels can be sensed. If the transient is too fast, the engine may run rich, increasing CO and HC emissions, or lean, increasing NOx emissions. Some of this effect can be reduced using a hybrid strategy that only allows slow transients, but this places greater strain on the LLD.

As a series hybrid vehicle decouples both the speed and the power of the APU from the speed and power requirement at the wheels, this extra degree of freedom can also be used to reduce emissions. For a given required power output, there are many combinations of speed and torque that could be used to provide that power. If the engine is run in a low speed, high load state, the fuel efficiency, noise, and hydrocarbon emissions are all improved. At high loads, however, the NOx emissions are high and traditional NOx reducing measures such as Exhaust Gas Recirculation (EGR) are more difficult. Choosing this optimum engine operating point as a function of power is an important design consideration but it is not necessarily part of the hybrid strategy design.

Anderson, Ex. 1006 at 7.

Severinsky and Anderson cannot be combined in the manner asserted by Ford

- Anderson's only disclosure of an actual hybrid strategy used to reduce emissions is for a series hybrid vehicle. Ex. 2002 at ¶72.
- Anderson's series strategy is premised on the output of the engine being decoupled from the wheels.

Parties dispute whether this sentence applies to series, parallel, or both

Strategy explicitly tied to series hybrid vehicles

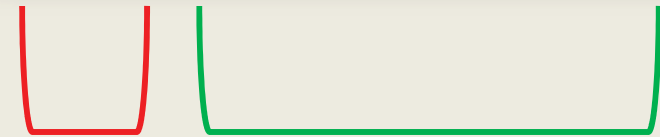

and HC emissions, or lean, increasing NOx emissions. Some of this effect can be reduced using a hybrid strategy that only allows slow transients, but this places greater strain on the LLD.

As a series hybrid vehicle decouples both the speed and the power of the APU from the speed and power requirement at the wheels, this extra degree of freedom can also be used to reduce emissions. For a given required power output, there are many combinations of speed and torque that could be used to provide that power. If the engine is run in a low speed, high load state, the fuel efficiency, noise, and hydrocarbon emissions are all improved. At high loads, however, the NOx emissions are high and traditional NOx reducing measures such as Exhaust Gas Recirculation (EGR) are more difficult. Choosing this optimum engine operating point as a function of power is an important design consideration but it is not necessarily part of the hybrid strategy design.

Anderson, Ex. 1006 at 7; Ex. 2002 at ¶ 71.

Severinsky and Anderson cannot be combined in the manner asserted by Ford

Contrary to Paice's argument, Anderson expressly describes the engine's "transient capabilities" in terms of "power output" and "combinations of speed and torque" for enabling greater optimization of the hybrid vehicle's powertrain. Ex. 1006 at 7 (emphasis added).

IPR '570, Paper No. 10, Institution Decision at 10.

Strategy explicitly tied to series hybrid vehicles

As a series hybrid vehicle decouples both the speed and the power of the APU from the speed and power requirement at the wheels, this extra degree of freedom can also be used to reduce emissions. For a given required power output, there are many combinations of speed and torque that could be used to provide that power. If the engine is run in a low speed, high load state, the fuel efficiency, noise, and hydrocarbon emissions are all improved. At high loads, however, the NOx emissions are high and traditional NOx reducing measures such as Exhaust Gas Recirculation (EGR) are more difficult. Choosing this optimum engine operating point as a function of power is an important design consideration but it is not necessarily part of the hybrid strategy design.

Anderson, Ex. 1006 at 7.

Severinsky and Anderson cannot be combined in the manner asserted by Ford

- As to the disputed sentence...

Parties dispute whether this sentence applies to series, parallel, or both

Strategy explicitly tied to series hybrid vehicles

and HC emissions, or lean, increasing NOx emissions. Some of this effect can be reduced using a hybrid strategy that only allows slow transients, but this places greater strain on the LLD.

As a series hybrid vehicle decouples both the speed and the power of the APU from the speed and power requirement at the wheels, this extra degree of freedom can also be used to reduce emissions. For a given required power output, there are many combinations of speed and torque that could be used to provide that power. If the engine is run in a low speed, high load state, the fuel efficiency, noise, and hydrocarbon emissions are all improved. At high loads, however, the NOx emissions are high and traditional NOx reducing measures such as Exhaust Gas Recirculation (EGR) are more difficult. Choosing this optimum engine operating point as a function of power is an important design consideration but it is not necessarily part of the hybrid strategy design.

Anderson, Ex. 1006 at 7; Ex. 2002 at ¶ 71.

Severinsky and Anderson cannot be combined in the manner asserted by Ford



- Mr. Hannemann explains that the disputed sentence excludes parallel hybrids.

Anderson's suggestion that some of this effect can be reduced using a hybrid strategy that only allows slow transients makes clear that it is not referring to the "following" strategy or to a parallel hybrid system. As noted above, Anderson teaches that the engine must perform fast transients when using the "following" strategy and that a parallel hybrid system always uses the "following" control strategy. *Id.* at 5.

Ex. 2002 at ¶ 70.

The other extreme commands the APU to follow the actual wheel power whenever possible (similar to a conventional automobile). Using this strategy, the LLD cycling will diminish, and the losses associated with charge and discharge will be minimized. The APU, however, must then operate over its entire range of power levels and perform fast power transients, both of which can adversely affect engine efficiency and emissions characteristics. Figure 6 shows the APU and LLD power requirements generated by this "following" mode for the same wheel power curve shown in figure 4. It should be noted that this is the mode a parallel hybrid vehicle always uses.

Anderson, Ex. 1006 at 5.

Some of this effect can be reduced using a hybrid strategy that only allows slow transients, but this places greater strain on the LLD.

Anderson, Ex. 1006 at 7.

Severinsky and Anderson cannot be combined in the manner asserted by Ford

- Dr. Stein's declaration testimony:

Declaration Testimony

A person having ordinary skill in the art would have understood that Anderson's statements: "[s]ome of this effect can be reduced using a hybrid strategy that only allows slow transients, but this places greater strain on the LLD", and "[e]missions characteristics may then be included by slowing down the engine transient response time" simply mean that a parallel HEV can reduce the transient emissions problem by supplementing the engine output torque with torque from another power source, namely an electric motor which receives electric power from the battery.

IPR '570, Ex. 1002 at ¶ 17.

Severinsky and Anderson cannot be combined in the manner asserted by Ford

- At his deposition, Dr. Stein admitted that the sentence in question is i) unrelated to a particular hybrid vehicle and ii) does not propose a particular hybrid strategy.

Deposition Testimony

14 Q. With that, the sentence you just 15:34:03
15 read that says, "Some of this effect can be 15:34:06
16 reduced using a hybrid strategy that only 15:34:09
17 allows slow transients, but this places greater 15:34:12
18 strain on the LLD," is that referring to a 15:34:16
19 series hybrid or a parallel hybrid? 15:34:19
20 MS. SHAH: Objection, asked and 15:34:22
21 answered, form. 15:34:23
22 A. I would answer as I did before that 15:34:29
23 the paper is about hybrid control strategies 15:34:39
24 and is talking about concepts of hybrid 15:34:43
25 control, showing how you can trade off 15:34:48
1 engineering concepts in the design of these 15:34:51
2 vehicles, and applies to parallel -- to all 15:34:56
3 types of vehicles. 15:35:01

14 Q. So you understand the sentence we're 15:48:11
15 talking about, right? It says: 15:48:14
16 "Some of this effect can be reduced 15:48:18
17 using a hybrid strategy that only allows slow 15:48:20
18 transients, but this places greater strain on 15:48:24
19 the LLD." 15:48:27
20 A. Yes, I see that sentence. 15:48:33
21 Q. Do you see that? 15:48:36
22 A. Yes. 15:48:37
23 Q. Is Anderson referring to a specific 15:48:37
24 hybrid strategy here that addresses the 15:48:40
25 emissions considerations that you've discussed 15:48:46
1 previously? 15:48:48
2 MS. SHAH: Objection, vague. 15:48:52
3 A. I mean the whole paper is about 15:49:07
4 coming up with a hybrid strategy. 15:49:09
5 Q. What is that hybrid strategy? 15:49:15
6 A. There isn't one. It's -- she's 15:49:17
7 suggesting that the space for coming up with 15:49:21
8 your hybrid strategy involves thinking about 15:49:25
9 the trade-off between different variables. 15:49:27
10 different issues as they relate to the 15:49:32
11 performance of a hybrid vehicle. 15:49:36

Ex. 2008 at 8:14 – 9:3.

Ex. 2008 at 16:17 – 17:11.

Severinsky and Anderson cannot be combined in the manner asserted by Ford

- Anderson's statement below means that the methodology of designing a hybrid control strategy and considering the effects of APU and battery characteristics and design trade-offs—can be applied to any type of vehicle. Anderson, Ex. 1006 at 4; Ex. 2002 at ¶64.

The thought processes presented in this paper are sufficiently general that they can be applied to any type of vehicle. To fully explore the flexibility allowed by the hybrid

Anderson, Ex. 1006 at 4.

Severinsky and Anderson cannot be combined in the manner asserted by Ford



Anderson's hybrid strategy to reduce emissions would not work in a parallel hybrid system such as the one disclosed in Severinsky.

Ex. 2002 at ¶ 83.

For example, since the APU in a series hybrid system is decoupled from the wheels and not used to propel the vehicle, the APU can be turned on to run at predefined constant power levels depending on the state of charge of the battery. Thus, APU transients occur less frequently, are predictable, are not time sensitive, can be predefined, and most importantly are not in response to the operator's command. In contrast, since the engine in a parallel hybrid system is used to propel the vehicle, the engine must follow the operator's command for propelling the vehicle and must perform fast transients. The engine transients occur frequently, are unpredictable, are time sensitive, and cannot be predefined in a parallel hybrid system.

Even if Severinsky and Anderson could be combined, Ford fails to provide any rationale supporting such a combination

- Ford's rationale to combine is flawed:

One skilled in the art would have had sufficient motivation to combine the two references as improved control of the stoichiometric air-fuel ratio is directly correlated to increasing fuel economy and reducing noxious emissions. These optimization considerations would have been desired by one of ordinary skill in the art at the time of the invention. (Stein Decl., FMC 1002, ¶397.)

IPR '570, Paper No. 1, Petition at 51.

Even if Severinsky and Anderson could be combined, Ford fails to provide any rationale supporting such a combination

- At his first deposition:
 - Dr. Stein could not answer basic questions regarding the Severinsky control strategy such as “[w]hat control strategy is utilized in the '970 patent” and “[i]s it a control strategy based on the speed of the vehicle.” See, e.g., Ex. 2004 at 272:21-273:3; 273:5-17.
 - When asked if Severinsky uses a “follower” mode strategy:



2 with respect to the '970 patent. 05:55:34
3 Did Dr. Severinsky use a follower 05:55:36
4 mode control structure? 05:55:39
5 A I have not studied in detail to 05:55:57
6 answer the question between that specific 05:55:59
7 follower mode that Anderson discusses and the 05:56:02
8 control modes of operation that the Severinsky 05:56:04
9 patent describes. 05:56:11
10 It wasn't part of my analysis. I 05:56:11
11 wasn't asked to look at that. 05:56:13

Ex. 2004 at 275:25-276:11.

Even if Severinsky and Anderson could be combined, Ford fails to provide any rationale supporting such a combination

- At his second deposition, Dr. Stein still could not describe how a POSITA would implement Anderson's teaching in Severinsky.



9 I'm just trying to figure out in 17:31:55
10 your opinion in which of these modes is one 17:31:57
11 skilled in the art going to apply the teachings 17:32:01
12 of Anderson? 17:32:02
13 MS. SHAH: Objection, vague. 17:32:06
14 A. I think that what I'm trying to show 17:32:35
15 in this paragraph here is that there's a -- one 17:32:37
16 of ordinary skill would recognize similarities 17:32:44
17 and connections between Severinsky's disclosure 17:32:59
18 and Anderson's teachings. 17:33:07

...

9 Q. So sitting here today, can you tell 17:34:32
10 me which one of these modes the Severinsky '970 17:34:34
11 would be modified to include Anderson's 17:34:38
12 teaching regarding limiting emissions? 17:34:43
13 MS. SHAH: Objection, vague. 17:34:50
14 A. I'm not sure what you're asking me 17:34:53
15 to do. You're asking me to design a vehicle by 17:34:55
16 combining the references? 17:34:57

Ex. 2008 at 59:3 – 60:16.

Even if Severinsky and Anderson could be combined, Ford fails to provide any rationale supporting such a combination



23 Q. So sitting here today, based on our 17:46:16
24 discussion of the low speed mode, the highway 17:46:18
25 cruising mode, the high speed/hill climbing 17:46:24
1 mode and the disclosure of the 60 to 90 percent 17:46:27
2 MTO sweet spot, you can't tell me how 17:46:31
3 Severinsky '970 switches from low speed mode to 17:46:36
4 highway cruising mode? 17:46:41
5 A. It was my understanding that the 17:46:42
6 mode selection strategy was not a part of this 17:46:45
7 IPR, and I didn't provide opinions about that 17:46:49
8 in my declaration, first declaration and my 17:47:00
9 reply declaration, which is here, just 17:47:08
10 clarifying issues that you guys brought up. 17:47:14
11 Q. Understood. 17:47:17
12 A. So I don't have any -- I haven't 17:47:18
13 prepared today to talk specifically about what 17:47:22
14 Severinsky does to switch modes. 17:47:26

Ex. 2008 at 66:23 – 67:14.

Even if Severinsky and Anderson could be combined, Ford fails to provide any rationale supporting such a combination

- Dr. Stein admits that in Severinsky's high-speed acceleration/hill climbing mode, both the engine and the motor provide torque to the vehicle because the operator has demanded torque beyond the torque that can be provided by the engine. Ex. 2004 at 162:19-164:16.

the operator's control inputs. Microprocessor 48 monitors the operator's inputs and the vehicle's performance, and activates electric motor 20 when torque in excess of the capabilities of engine 40 is required. Conversely, if

Severinsky, Ex. 1009 at 14:15-18.

Ground 6: Severinsky And Anderson Do Not Disclose Each And Every Claim Limitation of Claim 30

Severinsky And Anderson Do Not Disclose Each And Every Claim Limitation of Claim 30 of the '097 Patent

30. A hybrid vehicle, comprising:
an internal combustion engine operable to propel the hybrid vehicle by providing torque to the one or more wheels, wherein said engine has an inherent maximum rate of increase of output torque;
at least one electric motor operable to propel the hybrid vehicle by providing torque to the one or more wheels; a battery coupled to the at least one electric motor, operable to provide electrical power to the at least one electric motor; and
a controller, operable to control the flow of electrical and mechanical power between the engine, the at least one electric motor, and the one or more wheels, responsive to an operator command;
wherein said controller controls said at least one electric motor to provide additional torque when the amount of torque being provided by said engine is less than the amount of torque required to operate the vehicle; and
wherein said controller controls said engine such that a rate of increase of output torque of said engine is limited to less than said inherent maximum rate of increase of output torque, and wherein the controller is operable to limit the rate of change of torque produced by the engine such that combustion of fuel within the engine occurs at a substantially stoichiometric ratio.

Claim 30 requires that the controller limit the rate of increase of output torque of the engine to less than the inherent maximum rate of increasing of output torque resulting in substantially stoichiometric fuel combustion

'097 Patent, Claim 30

Severinsky and Anderson do not disclose or render obvious all of the limitations of claim 30 of the '097 Patent

Severinsky in view of Anderson fails to disclose or render obvious:

- 1) “wherein said controller controls said engine such that a rate of increase of output torque of said engine is limited.”**
- 2) “output torque of said engine is limited to less than said inherent maximum rate of increase of output torque.”**
- 3) “such that combustion of fuel within the engine occurs at a substantially stoichiometric ratio.”**

Severinsky and Anderson do not disclose or render obvious all of the limitations of claim 30 of the '097 Patent

Severinsky in view of Anderson fails to disclose or render obvious:

- 1) “wherein said controller controls said engine such that a rate of increase of output torque of said engine is limited.”**
- 2) “output torque of said engine is limited to less than said inherent maximum rate of increase of output torque.”**
- 3) “such that combustion of fuel within the engine occurs at a substantially stoichiometric ratio.”**

Severinsky and Anderson do not disclose “wherein the controller controls said engine such that a rate of increase of output torque of said engine is limited . . .”

- **Ford admits that Severinsky does not disclose this limitation**

Severinsky '970 does not explicitly disclose limiting the rate of change of engine output torque or operating the engine at a stoichiometric ratio.

IPR '570, Paper No. 1, Petition at 46.

Severinsky and Anderson do not disclose “wherein the controller controls said engine such that a rate of increase of output torque of said engine is limited . . .”

- Anderson merely teaches choosing engine characteristics (such as transient capabilities, fuel efficiency, and emissions) to design a hybrid control strategy that takes into account battery requirements. Ex. 2002 at ¶108.
- Anderson discloses that the transient capabilities are limited by the inherent mechanical characteristics of the engine itself. *Id.* at ¶109.

APU Transient Capabilities - Mechanically, the transient capabilities of an engine are limited by the inertia involved in increasing or decreasing the engine speed. Although slower transients are desirable for reducing emissions, slow transients can curtail the life of the battery or potentially harm the engine. For example, slow transients can be a serious problem

Anderson, Ex. 1006 at 7.

Severinsky and Anderson do not disclose “wherein the controller controls said engine such that a rate of increase of output torque of said engine is limited . . .”

- **Dr. Stein admitted that Anderson does not even teach a particular hybrid strategy—just a suggestion to consider trade-offs between different variables and issues. Ex. 2008 at 16:17 – 17:11.**

- **Dr. Stein admitted that choosing the size of the engine is part of the hybrid strategy. *Id.* at 30:20 – 33:15.**

- **Dr. Stein could not describe how a POSITA would implement Anderson’s teaching in Severinsky. *Id.* at 59:3 – 60:16.**

3 A. I mean the whole paper is about 15:49:07
4 coming up with a hybrid strategy. 15:49:09
5 Q. What is that hybrid strategy? 15:49:15
6 A. There isn't one. It's -- she's 15:49:17
7 suggesting that the space for coming up with 15:49:21
8 your hybrid strategy involves thinking about 15:49:25
9 the trade-off between different variables, 15:49:27
10 different issues as they relate to the 15:49:32
11 performance of a hybrid vehicle. 15:49:36

Ex. 2008 at 16:17 – 17:11.

Severinsky and Anderson do not disclose or render obvious all of the limitations of claim 30 of the '097 Patent

Severinsky in view of Anderson fails to disclose or render obvious:

- 1) “wherein said controller controls said engine such that a rate of increase of output torque of said engine is limited.”**
- 2) “output torque of said engine is limited to less than said inherent maximum rate of increase of output torque.”**
- 3) “such that combustion of fuel within the engine occurs at a substantially stoichiometric ratio.”**

Severinsky and Anderson do not disclose limiting the rate of increase of engine output torque

- There is no disclosure in Anderson of limiting the rate of increase of engine output torque.
- Anderson merely states that the APU transient characteristics are mechanically limited by inertia relating to increasing and decreasing engine speed, not engine torque. Ex. 2002 at ¶113.

APU Transient Capabilities - Mechanically, the transient capabilities of an engine are limited by the inertia involved in increasing or decreasing the engine speed. Although slower transients are desirable for reducing emissions, slow transients can curtail the life of the battery or potentially harm the engine. For example, slow transients can be a serious problem

Anderson, Ex. 1006 at 7.

Severinsky and Anderson do not disclose limiting the rate of increase of engine output torque

- The most charitable reading of Anderson is that it suggests using the freedom provided in a series hybrid to operate the engine at “given required power output” at a torque/speed point that reduces emissions.

As a series hybrid vehicle decouples both the speed and the power of the APU from the speed and power requirement at the wheels, this extra degree of freedom can also be used to reduce emissions. For a given required power output, there are many combinations of speed and torque that could be used to provide that power. If the engine is run in a low speed, high load state, the fuel efficiency, noise, and hydrocarbon emissions are all improved. At high loads, however, the NOx emissions are high and traditional NOx reducing measures such as Exhaust Gas Recirculation (EGR) are more difficult. Choosing this optimum engine operating point as a function of power is an important design consideration but it is not necessarily part of the hybrid strategy design.

Anderson, Ex. 1006 at 7; Ex. 2002 at ¶ 71.

Severinsky and Anderson do not disclose or render obvious all of the limitations of claim 30 of the '097 Patent

Severinsky in view of Anderson fails to disclose or render obvious:

- 1) “wherein said controller controls said engine such that a rate of increase of output torque of said engine is limited.”**
- 2) “output torque of said engine is limited to less than said inherent maximum rate of increase of output torque.”**
- 3) “such that combustion of fuel within the engine occurs at a substantially stoichiometric ratio.”**

Anderson's disclosure regarding stoichiometry is limited to conventional closed feedback systems

Discussion of conventional (non-hybrid) closed feedback system.

Discussion of "hybrid strategy"

Emissions - Frequently, one of the principle aims of a hybrid vehicle is to reduce vehicle emissions to ULEV (Ultra Low Emission Vehicle) levels. Consequently, APU emissions are very important for system success. In general, emissions are minimized when a **stoichiometric air to fuel ratio** is maintained by a closed loop feedback system (using an oxygen sensor for feedback). In some operating regimes, such as engine starts and transients, the **stoichiometric ratio** is very difficult to maintain resulting in an increase in emissions.

During a cold-start, the engine must run rich to achieve sufficient vaporization of the fuel. Rich running results in high hydrocarbons (HC) and carbon monoxide (CO) emissions, but low nitrogen oxides (NOx) emissions. A hot-start has many of the same problems as a cold start, but the time duration before the engine and catalytic converter warm up is much shorter. A hybrid strategy which minimizes engine cycling will minimize start-related emissions, but that may require that the engine have a higher turn-down ratio.

Transients present an emissions problem that is largely related to the speed of the transient. The closed loop feedback system that maintains the stoichiometric air fuel ratio is sufficient during quasi-steady state modes, however, it can only react as fast as the O₂ levels can be sensed. If the transient is too fast, the engine may run rich, increasing CO and HC emissions, or lean, increasing NOx emissions. Some of this effect can be reduced using a hybrid strategy that only allows slow transients, but this places greater strain on the LLD.

As a series hybrid vehicle decouples both the speed and the power of the APU from the speed and power requirement at the wheels, this extra degree of freedom can also be used to reduce emissions. For a given required power output, there are many combinations of speed and torque that could be used to provide that power. If the engine is run in a low speed, high load state, the fuel efficiency, noise, and hydrocarbon emissions are all improved. At high loads, however, the NOx emissions are high and traditional NOx reducing measures such as Exhaust Gas Recirculation (EGR) are more difficult. Choosing this optimum engine operating point as a function of power is an important design consideration but it is not necessarily part of the hybrid strategy design.

Nowhere does Anderson disclose a hybrid strategy that results in the combustion of fuel within the engine occurring at a substantially stoichiometric ratio.

- Anderson merely states that “some of this effect can be reduced using a hybrid strategy that only allows slow transients.” Anderson at 7; Ex. 2002 at ¶120.
- As discussed previously, Anderson expressly teaches that an engine with slow transient capabilities would not work in a parallel hybrid system. Anderson, Ex. 2002 at ¶120.

Discussion of “hybrid strategy”

Transients present an emissions problem that is largely related to the speed of the transient. The closed loop feedback system that maintains the stoichiometric air fuel ratio is sufficient during quasi-steady state modes, however, it can only react as fast as the O₂ levels can be sensed. If the transient is too fast, the engine may run rich, increasing CO and HC emissions, or lean, increasing NOx emissions. Some of this effect can be reduced using a hybrid strategy that only allows slow transients, but this places greater strain on the LLD.

As a series hybrid vehicle decouples both the speed and the power of the APU from the speed and power requirement at the wheels, this extra degree of freedom can also be used to reduce emissions. For a given required power output, there are many combinations of speed and torque that could be used to provide that power. If the engine is run in a low speed, high load state, the fuel efficiency, noise, and hydrocarbon emissions are all improved. At high loads, however, the NOx emissions are high and traditional NOx reducing measures such as Exhaust Gas Recirculation (EGR) are more difficult. Choosing this optimum engine operating point as a function of power is an important design consideration but it is not necessarily part of the hybrid strategy design.

Anderson, Ex. 1006 at 7.

Severinsky teaches away from operating at stoichiometry

- Severinsky expressly teaches operating in a lean burn mode. Ex. 2002, ¶ 94.
- Severinsky is more concerned with reducing nitrogen emissions. *Id.*

To lower the toxic hydrocarbon and carbon monoxide emissions from combustion, the engine 40 will be operated in lean burn mode (that is, air will be supplied slightly in excess of the amount required for stoichiometric combustion) to achieve complete combustion. To lower nitrogen oxide emissions, the engine will be operated at a lower temperature and thus at slightly reduced thermodynamic efficiency (e.g., 2-3% lower) than is a conventional engine. Only 2 or 3 cylinders will

Severinsky, Ex. 1009 at 12:13-22.

Toxic pollutants such as nitrogen oxides, carbon monoxide and hydrocarbons will be reduced by 200-300% simply through use of less fuel. As indicated above, a further reduction can be obtained by operating the engine in a lean burn mode. Although reduction of the combustion temperature in order to reduce the amount of nitrogen oxides emitted also reduces the thermodynamic efficiency, this technique can still be usefully employed; the improvement in fuel efficiency realized according to the invention is so high that a slight reduction in thermodynamic efficiency resulting in the reduction of the amount of nitrogen oxides emitted can be tolerated without substantial loss in overall economy.

Severinsky, Ex. 1009 at 21:9-13.

Severinsky and Anderson do not disclose or render obvious the controller limitation

30. A hybrid vehicle, comprising:
an internal combustion engine operable to propel the hybrid vehicle by providing torque to the one or more wheels, wherein said engine has an inherent maximum rate of increase of output torque;
at least one electric motor operable to propel the hybrid vehicle by providing torque to the one or more wheels; a battery coupled to the at least one electric motor, operable to provide electrical power to the at least one electric motor; and
a controller, operable to control the flow of electrical and mechanical power between the engine, the at least one electric motor, and the one or more wheels, responsive to an operator command;
wherein said controller controls said at least one electric motor to provide additional torque when the amount of torque being provided by said engine is less than the amount of torque required to operate the vehicle; and
wherein said controller controls said engine such that a rate of increase of output torque of said engine is limited to less than said inherent maximum rate of increase of output torque, and wherein the controller is operable to limit the rate of change of torque produced by the engine such that combustion of fuel within the engine occurs at a substantially stoichiometric ratio.

Claim 30 requires a controller that controls the engine responsive to an operator command and controls the motor to provide additional torque and controls the engine by limiting the rate of increase of output torque to maintain stoichiometry.

‘097 Patent, Claim 30

Severinsky and Anderson do not disclose or render obvious the controller limitation

30. A hybrid vehicle, comprising:
one or more wheels;
an internal combustion engine operable to propel the hybrid vehicle by providing torque to the one or more wheels, wherein said engine has an inherent maximum rate of increase of output torque;
at least one electric motor operable to propel the hybrid vehicle by providing torque to the one or more wheels; a battery coupled to the at least one electric motor, operable to provide electrical power to the at least one electric motor; and
a controller, operable to control the flow of electrical and mechanical power between the engine, the at least one electric motor, and the one or more wheels, responsive to an operator command;
wherein said controller controls said at least one electric motor to provide additional torque when the amount of torque being provided by said engine is less than the amount of torque required to operate the vehicle; and
wherein said controller controls said engine such that a rate of increase of output torque of said engine is limited to less than said inherent maximum rate of increase of output torque, and wherein the controller is operable to limit the rate of change of torque produced by the engine such that combustion of fuel within the engine occurs at a substantially stoichiometric ratio.

Severinsky and Anderson do not disclose the controller limitation

wherein said controller controls said engine such that a rate of increase of output torque of said engine is limited to less than said inherent maximum rate of increase of output torque, and wherein the controller is operable to limit the rate of change of torque produced by the engine such that combustion of fuel within the engine occurs at a substantially stoichiometric ratio.

wherein said controller controls said at least one electric motor to provide additional torque when the amount of torque being provided by said engine is less than the amount of torque required to operate the vehicle.

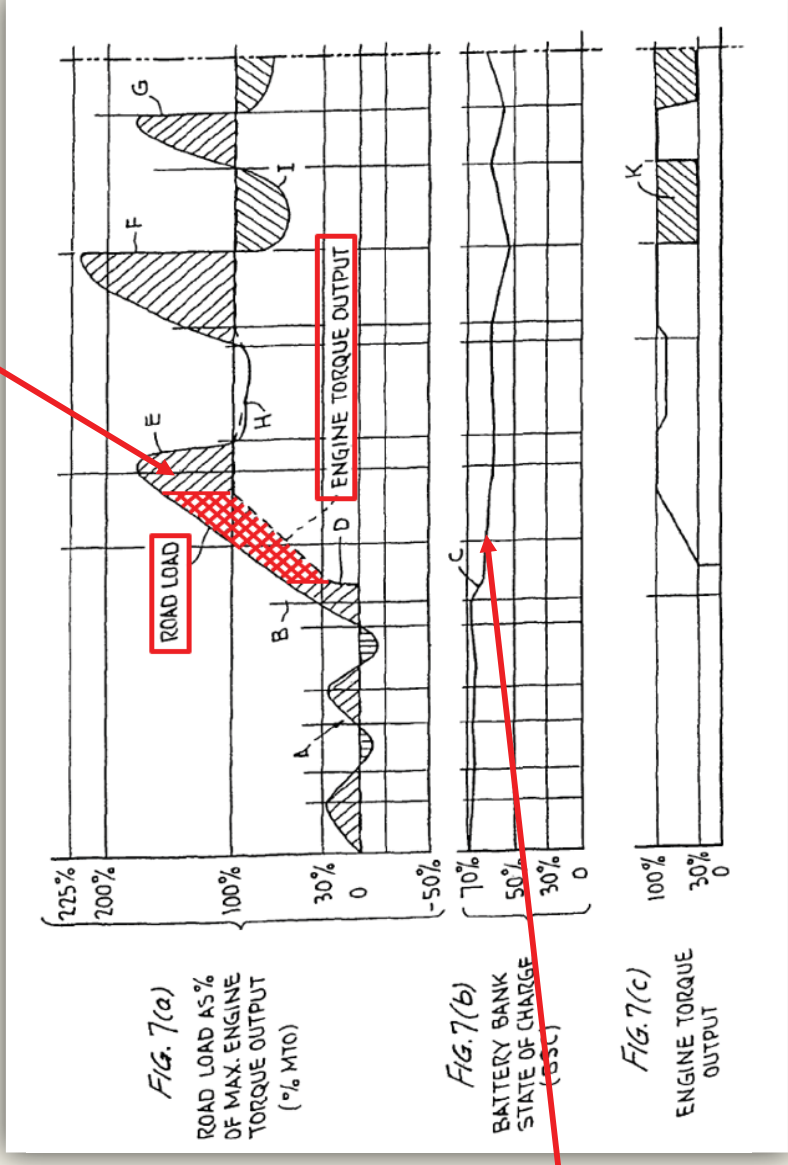

'097 Patent at Fig. 7.

Ground 7: Severinsky, Anderson, And Yamaguchi Do Not Disclose or Render Obvious Claim 32 of the '097 Patent

'097 Patent Claim 32 Introduction

32. The hybrid vehicle of claim **30**, wherein when it is desired to start said engine, said engine is rotated at at least 300 rpm, whereby the engine is heated, prior to supply of fuel for starting the engine.

'097 Patent, Claim 32.

Introduction to Yamaguchi

Yamaguchi (Ex. 1007) is directed to a hybrid vehicle that uses an engine interruption system for stopping and starting the engine during operation.



US005865263A

United States Patent [19]
Yamaguchi et al.

[11] **Patent Number:** 5,865,263
 [45] **Date of Patent:** Feb. 2, 1999

[54] **HYBRID VEHICLE**
 [75] **Inventors:** Koza Yamaguchi; Yoshihazu Yamaguchi; Hiideki Nakashima, all of Aichi-ken, Japan
 [73] **Assignee:** Kabushiki Kaisha Equus Research, Japan

[21] **Appl. No.:** 609,762
 [22] **Filed:** Feb. 23, 1996

[30] **Foreign Application Priority Data**
 Feb. 28, 1995 [JP] Japan 7,003,538
 [51] **Int. Cl.:** B60K 6/00
 [52] **U.S. Cl.:** 180/65.2
 [58] **Field of Search:** 180/65.2, 65.3, 180/65.4, 65.6, 65.8; 364/424.02; 123/179.3

[56] **References Cited**
U.S. PATENT DOCUMENTS
 1,848,091 3/1932 Wither 180/65.2
 3,566,717 3/1971 Bernau et al. 180/65.2
 3,605,622 10/1971 Bernau et al. 180/65.2
 3,861,484 1/1975 Jodan et al. 180/65.2
 4,022,164 5/1977 Fuchs 123/179.3
 4,122,354 10/1978 Howland 123/179.3

FOREIGN PATENT DOCUMENTS
 0570234 5/1993 European Pat. Off. 180/65.4
 4,335,429 6/1982 Kawasaki 180/65.2
 5,169,576 1/1994 Saito 180/65.2
 5,343,070 3/1994 Sawatsky 180/65.2
 5,698,905 12/1997 Bolllein 180/65.4

PRIMARY EXAMINER—Brian L. Johnson
ASSISTANT EXAMINER—Frank Vainaman
ATTORNEY, AGENT, OR FIRM—Lorusso & Lord

ABSTRACT
 A hybrid vehicle has an engine and a generator/motor connected through a planetary gear unit to an output shaft and the output of the engine is distributed between the generator and the output shaft. The vehicle is smoothly started by a driving motor. When vehicle speed V reaches an engine starting speed V*, the speed of generator/motor is changed to cause the engine to rotate, the engine is ignited and driving continues with the output torque produced by the engine supplemented by the driving motor. A hybrid vehicle is provided that has an engine interruption scheme for halting the engine is employed, for example, halting the vehicle while waiting for a traffic signal to change.

19 Claims, 8 Drawing Sheets

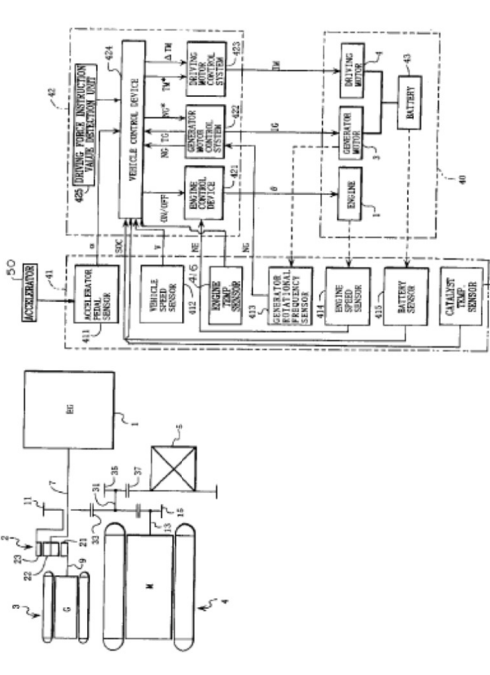

Severinsky teaches away from heating the engine

- Severinsky expressly teaches away from heating the engine. Ex. 2002, ¶123.
- Instead, Severinsky teaches reducing combustion temperature and operating the engine at a lower temperature to lower nitrogen oxide emissions. *Id.*

To lower the toxic hydrocarbon and carbon monoxide emissions from combustion, the engine 40 will be operated in lean burn mode (that is, air will be supplied slightly in excess of the amount required for stoichiometric combustion) to achieve complete combustion. To lower nitrogen oxide emissions, the engine will be operated at a lower temperature and thus at slightly reduced thermodynamic efficiency (e.g., 2-3% lower) than is a conventional engine. Only 2 or 3 cylinders will

Severinsky, Ex. 1009 at 12:13-22.

Ground 8: Severinsky, Anderson, And Katsuno Do Not Disclose or Render Obvious Claim 33 of the '097 Patent

'097 Patent Claim 33 Introduction

33. The hybrid vehicle of claim 32, wherein fuel and air are supplied to said engine at a fuel:air ratio of no more than 1.2 of the stoichiometric ratio for starting the engine.

'097 Patent, Claim 33.

Katsuno (Ex. 1008) is directed to a conventional (i.e., non-hybrid) vehicle.

United States Patent [19] **Patent Number: 4,707,984**
Katsuno et al. [45] **Date of Patent: Nov. 24, 1987**

[54] **DOUBLE AIR-FUEL RATIO SENSOR SYSTEM HAVING IMPROVED RESPONSE CHARACTERISTICS**

[75] **Inventors:** Toshiyasu Katsuno; Toshinari Nagai, both of Saitama; Takashi Yamazaki, both of Saitama, both of Mahama, all of Japan.

[73] **Assignee:** Toyota Jidosha Kabushiki Kaisha, Aichi, Japan.

[21] **Appl. No.:** 856,019

[22] **Filed:** Apr. 11, 1986

[30] **Foreign Application Priority Data**

Apr. 15, 1985 [JP]	Japan	60-78528
Jun. 13, 1985 [JP]	Japan	60-127119
Jun. 17, 1985 [JP]	Japan	60-129905

[51] **Int. Cl.** F02D 41/14

[52] **U.S. Cl.** 60/274; 60/276; 60/285; 123/489; 123/491; 123/440; 489; 589; 491;

[58] **Field of Search** 123/440, 489, 589, 491; 60/276, 285, 274; 364/931,05

[56] **References Cited**

3,959,654	2/1976	Cress	60/276
4,027,477	6/1977	Stoney	60/276
4,130,095	12/1978	Bowler et al.	123/440
4,235,204	11/1980	Ries	123/440
4,234,989	2/1981	Nonimata et al.	123/440
4,395,792	8/1982	Owada et al.	123/440
4,497,296	2/1983	Nakajima et al.	123/489
4,539,938	9/1985	Ito et al.	123/440
4,611,600	7/1986	Henon	123/440
4,571,033	2/1986	Kobayashi et al.	364/431,05

FOREIGN PATENT DOCUMENTS

52-102934	8/1977	Japan
53-103796	9/1978	Japan
55-57562	3/1980	Japan
56-103796	9/1981	Japan
57-32773	7/1982	Japan
57-32774	7/1982	Japan
58-27948	2/1983	Japan
58-48755	3/1983	Japan
58-48756	3/1983	Japan
58-72646	4/1983	Japan
58-13543	8/1983	Japan
58-152147	9/1983	Japan
58-150358	9/1983	Japan
59-26644	2/1984	Japan
59-26638	1/1984	Japan
60-50138	8/1985	Japan
60-53635	3/1985	Japan
61-84330	2/1986	Japan
61-53436	3/1986	Japan

Primary Examiner—Andrew M. Dolinar
Attorney, Agent, or Firm—Pardhurst & Olliff

[57] **ABSTRACT**

In a double air-fuel sensor system including two air-fuel ratio sensors upstream and downstream of a catalyst converter provided in an exhaust gas passage, an air-fuel ratio sensor is provided upstream of the catalyst converter, and the upstream-side air-fuel ratio sensor and the downstream-side air-fuel ratio sensor. The adjustment of the actual air-fuel ratio by the downstream-side air-fuel ratio sensor is prohibited in accordance with a coolant temperature of the engine.

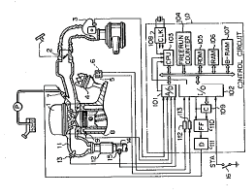

38 Claims, 62 Drawing Figures

Page 1 of 43

FMC 1008

Severinsky in view of Anderson and Katsumo fail to disclose or render obvious claim 33 of the '097 Patent

- Claim 33 specifically requires that fuel and air is supplied at a ratio of no more than 1.2 of the stoichiometric ratio for starting the engine. Ex. 2002 at ¶136.

33. The hybrid vehicle of claim 32, wherein fuel and air are supplied to said engine at a fuel:air ratio of no more than 1.2 of the stoichiometric ratio **for starting the engine**.

'097 Patent, Claim 33.

- Katsumo does not apply any control when the engine is in a starting state. Katsumo, Ex. 1008 at 5:61-64; see also Ex. 2002 at ¶¶139-142.

Severinsky in view of Anderson and Katsuno fail to disclose or render obvious claim 33 of the '097 Patent

- Katsuno operates the engine in “open-loop” when closed loop control conditions are not satisfied (e.g., the engine is in a starting state).

At step 501, it is determined whether or not all the feedback control (closed-loop control) conditions by the upstream-side O₂ sensor 13 are satisfied. The feedback control conditions are as follows:

- (i) the engine is not in a starting state;
- (ii) the coolant temperature THW is higher than 50° C.;
- (iii) the power fuel incremental amount FPOWER is 0; and
- (iv) the upstream-side O₂ sensor 13 is in an activated state.

Katsuno, Ex. 1008 at 5:40-50 and 6:1-3; see a/so Ex. 2002 at ¶137.

- In open-loop control, Katsuno sets the air-fuel ratio correction amount to 1.0 [multiplies by 1] so no correction of the actual air-fuel ratio occurs.

If one or more of the feedback control conditions is not satisfied, the control proceeds to step 527, in which the amount FAF1 is caused to be 1.0 (FAF1=1.0), thereby carrying out an open-loop control operation.

Katsuno, Ex. 1008 at 5:61-64; see a/so Ex. 2002 at ¶¶139-142.

END

IPR2014-00875

Introduction

- U.S. Patent No. 7,559,388
- Ground 1 (§ 103):
 - Challenged claims: 1, 3, 19
 - Asserted Art: Ehsani and Vittone
- Ground 2 (§ 103):
 - Challenged claim: 2
 - Asserted Art: Ehsani, Vittone and Caraceni
- Ground 3 (§ 103):
 - Challenged claim: 6
 - Asserted Art: Ehsani, Vittone and Fjallstrom
- Ground 4 (§ 103):
 - Challenged claim: 12
 - Asserted Art: Ehsani, Vittone and Yamaguchi
- Ground 5 (§ 103):
 - Challenged claims: 1, 3, 4, 19
 - Asserted Art: Kawakatsu and Vittone

Introduction to the '388 Patent

● '388 Patent (Ex. 1001) is directed to hybrid vehicles and control systems thereof

● The '388 patent recognized that the "vehicle operational mode should preferably be controlled in response to the vehicle's actual torque requirements, i.e., the road load."

● Use of "road load" according to the patent provides "superior performance, in terms of both vehicle response to operator commands and fuel efficiency, under the widely varying conditions encountered in 'real world' driving situations."



(10) Patent No.: **US 7,559,388 B2**
 (45) Date of Patent: **Jul. 14, 2009**

(56) **References Cited**
 U.S. PATENT DOCUMENTS
 5,669,842 A 9/1997 Schmidt
 5,759,117 A 5/1999 Nakamura et al.
 5,916,131 A 6/1999 Nakamura et al.
 6,019,183 A 2/2000 Shimizu
 6,030,697 A 2/2000 Shimizu
 6,030,697 B1 2/2000 Shimizu
 6,285,379 B1 3/2000 Berg
 6,383,114 B1 5/2002 Hoshoya et al.

FOREIGN PATENT DOCUMENTS
 JP 5317521 10/1990
 JP 02101083 4/1992
 JP 04314657 11/1992
 JP 06144020 5/1994

Primary Examiner—Christopher P. Ellis
Assistant Examiner—Vaughn T. Coolman
 (74) *Attorney, Agent, or Firm*—Michael de Angelis

(57) **ABSTRACT**

A hybrid vehicle comprises an internal combustion engine, a traction motor, a starter motor, and a battery bank, all controlled by a microprocessor in accordance with the vehicle's actual torque requirements. The microprocessor controls the engine and the traction motor under conditions of high efficiency, typically only when the load is at least equal to 30% of the engine's maximum torque output. In some embodiments, a turbocharger may be provided, activated only when the load exceeds the engine's maximum torque output for an extended period. A power-split mechanism is provided to provide linear torque to the vehicle's load range. A hybrid brake system provides regenerative braking, with mechanical braking available in the event the battery bank is fully charged, in emergencies, or at rest; a control mechanism is provided to control the brake system to provide linear brake feel under varying circumstances.

(12) **United States Patent**
Severinsky et al.

(54) **HYBRID VEHICLES**
 Inventors: Alex J. Severinsky, Washington, DC
 (US); Theodore Loucks, Holly, MI
 (US)
 Assignee: **Pace LLC**, Bonita Springs, FL (US)
 (*) Notice: Subject to any disclaimer, the term of this patent is extended or adjusted under 35 U.S.C. 154(b) by 481 days.

(21) Appl. No.: **11/0429,408**
 (22) Filed: **May 8, 2006**
 (65) **Prior Publication Data**
 US 2006/0231304A1 Oct. 19, 2006
Related U.S. Application Data

(60) Division of application No. 10/382,577, filed on Mar. 7, 2005, now No. 6,922,346, which is a division of application No. 10/382,577, filed on Mar. 7, 2005, now No. 6,534,088, which is a continuation-in-part of application No. 09/264,817, filed on Mar. 9, 1999, now Pat. No. 6,209,672, said application No. 10/382,577 is a continuation-in-part of application No. 09/392,743, filed on Sep. 3, 1999, now Pat. No. 6,338,391.
 (60) Provisional application No. 60/100,095, filed on Sep. 14, 1998, provisional application No. 60/122,296, filed on Mar. 1, 1999.

(51) **Int. Cl.** (2006.01) **B60P 10/06**
 (52) **U.S. Cl.** (2006.01) **180/65.28; 180/65.21; 180/65.2; 65/31; 65/32; 65/33; 65/34; 65/35; 65/36; 65/37; 65/38; 65/39; 65/40; 65/41; 65/42; 65/43; 65/44; 65/45; 65/46; 65/47; 65/48; 65/49; 65/50; 65/51; 65/52; 65/53; 65/54; 65/55; 65/56; 65/57; 65/58; 65/59; 65/60; 65/61; 65/62; 65/63; 65/64; 65/65; 65/66; 65/67; 65/68; 65/69; 65/70; 65/71; 65/72; 65/73; 65/74; 65/75; 65/76; 65/77; 65/78; 65/79; 65/80; 65/81; 65/82; 65/83; 65/84; 65/85; 65/86; 65/87; 65/88; 65/89; 65/90; 65/91; 65/92; 65/93; 65/94; 65/95; 65/96; 65/97; 65/98; 65/99; 66/01; 66/02; 66/03; 66/04; 66/05; 66/06; 66/07; 66/08; 66/09; 66/10; 66/11; 66/12; 66/13; 66/14; 66/15; 66/16; 66/17; 66/18; 66/19; 66/20; 66/21; 66/22; 66/23; 66/24; 66/25; 66/26; 66/27; 66/28; 66/29; 66/30; 66/31; 66/32; 66/33; 66/34; 66/35; 66/36; 66/37; 66/38; 66/39; 66/40; 66/41; 66/42; 66/43; 66/44; 66/45; 66/46; 66/47; 66/48; 66/49; 66/50; 66/51; 66/52; 66/53; 66/54; 66/55; 66/56; 66/57; 66/58; 66/59; 66/60; 66/61; 66/62; 66/63; 66/64; 66/65; 66/66; 66/67; 66/68; 66/69; 66/70; 66/71; 66/72; 66/73; 66/74; 66/75; 66/76; 66/77; 66/78; 66/79; 66/80; 66/81; 66/82; 66/83; 66/84; 66/85; 66/86; 66/87; 66/88; 66/89; 66/90; 66/91; 66/92; 66/93; 66/94; 66/95; 66/96; 66/97; 66/98; 66/99; 67/01; 67/02; 67/03; 67/04; 67/05; 67/06; 67/07; 67/08; 67/09; 67/10; 67/11; 67/12; 67/13; 67/14; 67/15; 67/16; 67/17; 67/18; 67/19; 67/20; 67/21; 67/22; 67/23; 67/24; 67/25; 67/26; 67/27; 67/28; 67/29; 67/30; 67/31; 67/32; 67/33; 67/34; 67/35; 67/36; 67/37; 67/38; 67/39; 67/40; 67/41; 67/42; 67/43; 67/44; 67/45; 67/46; 67/47; 67/48; 67/49; 67/50; 67/51; 67/52; 67/53; 67/54; 67/55; 67/56; 67/57; 67/58; 67/59; 67/60; 67/61; 67/62; 67/63; 67/64; 67/65; 67/66; 67/67; 67/68; 67/69; 67/70; 67/71; 67/72; 67/73; 67/74; 67/75; 67/76; 67/77; 67/78; 67/79; 67/80; 67/81; 67/82; 67/83; 67/84; 67/85; 67/86; 67/87; 67/88; 67/89; 67/90; 67/91; 67/92; 67/93; 67/94; 67/95; 67/96; 67/97; 67/98; 67/99; 68/01; 68/02; 68/03; 68/04; 68/05; 68/06; 68/07; 68/08; 68/09; 68/10; 68/11; 68/12; 68/13; 68/14; 68/15; 68/16; 68/17; 68/18; 68/19; 68/20; 68/21; 68/22; 68/23; 68/24; 68/25; 68/26; 68/27; 68/28; 68/29; 68/30; 68/31; 68/32; 68/33; 68/34; 68/35; 68/36; 68/37; 68/38; 68/39; 68/40; 68/41; 68/42; 68/43; 68/44; 68/45; 68/46; 68/47; 68/48; 68/49; 68/50; 68/51; 68/52; 68/53; 68/54; 68/55; 68/56; 68/57; 68/58; 68/59; 68/60; 68/61; 68/62; 68/63; 68/64; 68/65; 68/66; 68/67; 68/68; 68/69; 68/70; 68/71; 68/72; 68/73; 68/74; 68/75; 68/76; 68/77; 68/78; 68/79; 68/80; 68/81; 68/82; 68/83; 68/84; 68/85; 68/86; 68/87; 68/88; 68/89; 68/90; 68/91; 68/92; 68/93; 68/94; 68/95; 68/96; 68/97; 68/98; 68/99; 69/01; 69/02; 69/03; 69/04; 69/05; 69/06; 69/07; 69/08; 69/09; 69/10; 69/11; 69/12; 69/13; 69/14; 69/15; 69/16; 69/17; 69/18; 69/19; 69/20; 69/21; 69/22; 69/23; 69/24; 69/25; 69/26; 69/27; 69/28; 69/29; 69/30; 69/31; 69/32; 69/33; 69/34; 69/35; 69/36; 69/37; 69/38; 69/39; 69/40; 69/41; 69/42; 69/43; 69/44; 69/45; 69/46; 69/47; 69/48; 69/49; 69/50; 69/51; 69/52; 69/53; 69/54; 69/55; 69/56; 69/57; 69/58; 69/59; 69/60; 69/61; 69/62; 69/63; 69/64; 69/65; 69/66; 69/67; 69/68; 69/69; 69/70; 69/71; 69/72; 69/73; 69/74; 69/75; 69/76; 69/77; 69/78; 69/79; 69/80; 69/81; 69/82; 69/83; 69/84; 69/85; 69/86; 69/87; 69/88; 69/89; 69/90; 69/91; 69/92; 69/93; 69/94; 69/95; 69/96; 69/97; 69/98; 69/99; 70/01; 70/02; 70/03; 70/04; 70/05; 70/06; 70/07; 70/08; 70/09; 70/10; 70/11; 70/12; 70/13; 70/14; 70/15; 70/16; 70/17; 70/18; 70/19; 70/20; 70/21; 70/22; 70/23; 70/24; 70/25; 70/26; 70/27; 70/28; 70/29; 70/30; 70/31; 70/32; 70/33; 70/34; 70/35; 70/36; 70/37; 70/38; 70/39; 70/40; 70/41; 70/42; 70/43; 70/44; 70/45; 70/46; 70/47; 70/48; 70/49; 70/50; 70/51; 70/52; 70/53; 70/54; 70/55; 70/56; 70/57; 70/58; 70/59; 70/60; 70/61; 70/62; 70/63; 70/64; 70/65; 70/66; 70/67; 70/68; 70/69; 70/70; 70/71; 70/72; 70/73; 70/74; 70/75; 70/76; 70/77; 70/78; 70/79; 70/80; 70/81; 70/82; 70/83; 70/84; 70/85; 70/86; 70/87; 70/88; 70/89; 70/90; 70/91; 70/92; 70/93; 70/94; 70/95; 70/96; 70/97; 70/98; 70/99; 71/01; 71/02; 71/03; 71/04; 71/05; 71/06; 71/07; 71/08; 71/09; 71/10; 71/11; 71/12; 71/13; 71/14; 71/15; 71/16; 71/17; 71/18; 71/19; 71/20; 71/21; 71/22; 71/23; 71/24; 71/25; 71/26; 71/27; 71/28; 71/29; 71/30; 71/31; 71/32; 71/33; 71/34; 71/35; 71/36; 71/37; 71/38; 71/39; 71/40; 71/41; 71/42; 71/43; 71/44; 71/45; 71/46; 71/47; 71/48; 71/49; 71/50; 71/51; 71/52; 71/53; 71/54; 71/55; 71/56; 71/57; 71/58; 71/59; 71/60; 71/61; 71/62; 71/63; 71/64; 71/65; 71/66; 71/67; 71/68; 71/69; 71/70; 71/71; 71/72; 71/73; 71/74; 71/75; 71/76; 71/77; 71/78; 71/79; 71/80; 71/81; 71/82; 71/83; 71/84; 71/85; 71/86; 71/87; 71/88; 71/89; 71/90; 71/91; 71/92; 71/93; 71/94; 71/95; 71/96; 71/97; 71/98; 71/99; 72/01; 72/02; 72/03; 72/04; 72/05; 72/06; 72/07; 72/08; 72/09; 72/10; 72/11; 72/12; 72/13; 72/14; 72/15; 72/16; 72/17; 72/18; 72/19; 72/20; 72/21; 72/22; 72/23; 72/24; 72/25; 72/26; 72/27; 72/28; 72/29; 72/30; 72/31; 72/32; 72/33; 72/34; 72/35; 72/36; 72/37; 72/38; 72/39; 72/40; 72/41; 72/42; 72/43; 72/44; 72/45; 72/46; 72/47; 72/48; 72/49; 72/50; 72/51; 72/52; 72/53; 72/54; 72/55; 72/56; 72/57; 72/58; 72/59; 72/60; 72/61; 72/62; 72/63; 72/64; 72/65; 72/66; 72/67; 72/68; 72/69; 72/70; 72/71; 72/72; 72/73; 72/74; 72/75; 72/76; 72/77; 72/78; 72/79; 72/80; 72/81; 72/82; 72/83; 72/84; 72/85; 72/86; 72/87; 72/88; 72/89; 72/90; 72/91; 72/92; 72/93; 72/94; 72/95; 72/96; 72/97; 72/98; 72/99; 73/01; 73/02; 73/03; 73/04; 73/05; 73/06; 73/07; 73/08; 73/09; 73/10; 73/11; 73/12; 73/13; 73/14; 73/15; 73/16; 73/17; 73/18; 73/19; 73/20; 73/21; 73/22; 73/23; 73/24; 73/25; 73/26; 73/27; 73/28; 73/29; 73/30; 73/31; 73/32; 73/33; 73/34; 73/35; 73/36; 73/37; 73/38; 73/39; 73/40; 73/41; 73/42; 73/43; 73/44; 73/45; 73/46; 73/47; 73/48; 73/49; 73/50; 73/51; 73/52; 73/53; 73/54; 73/55; 73/56; 73/57; 73/58; 73/59; 73/60; 73/61; 73/62; 73/63; 73/64; 73/65; 73/66; 73/67; 73/68; 73/69; 73/70; 73/71; 73/72; 73/73; 73/74; 73/75; 73/76; 73/77; 73/78; 73/79; 73/80; 73/81; 73/82; 73/83; 73/84; 73/85; 73/86; 73/87; 73/88; 73/89; 73/90; 73/91; 73/92; 73/93; 73/94; 73/95; 73/96; 73/97; 73/98; 73/99; 74/01; 74/02; 74/03; 74/04; 74/05; 74/06; 74/07; 74/08; 74/09; 74/10; 74/11; 74/12; 74/13; 74/14; 74/15; 74/16; 74/17; 74/18; 74/19; 74/20; 74/21; 74/22; 74/23; 74/24; 74/25; 74/26; 74/27; 74/28; 74/29; 74/30; 74/31; 74/32; 74/33; 74/34; 74/35; 74/36; 74/37; 74/38; 74/39; 74/40; 74/41; 74/42; 74/43; 74/44; 74/45; 74/46; 74/47; 74/48; 74/49; 74/50; 74/51; 74/52; 74/53; 74/54; 74/55; 74/56; 74/57; 74/58; 74/59; 74/60; 74/61; 74/62; 74/63; 74/64; 74/65; 74/66; 74/67; 74/68; 74/69; 74/70; 74/71; 74/72; 74/73; 74/74; 74/75; 74/76; 74/77; 74/78; 74/79; 74/80; 74/81; 74/82; 74/83; 74/84; 74/85; 74/86; 74/87; 74/88; 74/89; 74/90; 74/91; 74/92; 74/93; 74/94; 74/95; 74/96; 74/97; 74/98; 74/99; 75/01; 75/02; 75/03; 75/04; 75/05; 75/06; 75/07; 75/08; 75/09; 75/10; 75/11; 75/12; 75/13; 75/14; 75/15; 75/16; 75/17; 75/18; 75/19; 75/20; 75/21; 75/22; 75/23; 75/24; 75/25; 75/26; 75/27; 75/28; 75/29; 75/30; 75/31; 75/32; 75/33; 75/34; 75/35; 75/36; 75/37; 75/38; 75/39; 75/40; 75/41; 75/42; 75/43; 75/44; 75/45; 75/46; 75/47; 75/48; 75/49; 75/50; 75/51; 75/52; 75/53; 75/54; 75/55; 75/56; 75/57; 75/58; 75/59; 75/60; 75/61; 75/62; 75/63; 75/64; 75/65; 75/66; 75/67; 75/68; 75/69; 75/70; 75/71; 75/72; 75/73; 75/74; 75/75; 75/76; 75/77; 75/78; 75/79; 75/80; 75/81; 75/82; 75/83; 75/84; 75/85; 75/86; 75/87; 75/88; 75/89; 75/90; 75/91; 75/92; 75/93; 75/94; 75/95; 75/96; 75/97; 75/98; 75/99; 76/01; 76/02; 76/03; 76/04; 76/05; 76/06; 76/07; 76/08; 76/09; 76/10; 76/11; 76/12; 76/13; 76/14; 76/15; 76/16; 76/17; 76/18; 76/19; 76/20; 76/21; 76/22; 76/23; 76/24; 76/25; 76/26; 76/27; 76/28; 76/29; 76/30; 76/31; 76/32; 76/33; 76/34; 76/35; 76/36; 76/37; 76/38; 76/39; 76/40; 76/41; 76/42; 76/43; 76/44; 76/45; 76/46; 76/47; 76/48; 76/49; 76/50; 76/51; 76/52; 76/53; 76/54; 76/55; 76/56; 76/57; 76/58; 76/59; 76/60; 76/61; 76/62; 76/63; 76/64; 76/65; 76/66; 76/67; 76/68; 76/69; 76/70; 76/71; 76/72; 76/73; 76/74; 76/75; 76/76; 76/77; 76/78; 76/79; 76/80; 76/81; 76/82; 76/83; 76/84; 76/85; 76/86; 76/87; 76/88; 76/89; 76/90; 76/91; 76/92; 76/93; 76/94; 76/95; 76/96; 76/97; 76/98; 76/99; 77/01; 77/02; 77/03; 77/04; 77/05; 77/06; 77/07; 77/08; 77/09; 77/10; 77/11; 77/12; 77/13; 77/14; 77/15; 77/16; 77/17; 77/18; 77/19; 77/20; 77/21; 77/22; 77/23; 77/24; 77/25; 77/26; 77/27; 77/28; 77/29; 77/30; 77/31; 77/32; 77/33; 77/34; 77/35; 77/36; 77/37; 77/38; 77/39; 77/40; 77/41; 77/42; 77/43; 77/44; 77/45; 77/46; 77/47; 77/48; 77/49; 77/50; 77/51; 77/52; 77/53; 77/54; 77/55; 77/56; 77/57; 77/58; 77/59; 77/60; 77/61; 77/62; 77/63; 77/64; 77/65; 77/66; 77/67; 77/68; 77/69; 77/70; 77/71; 77/72; 77/73; 77/74; 77/75; 77/76; 77/77; 77/78; 77/79; 77/80; 77/81; 77/82; 77/83; 77/84; 77/85; 77/86; 77/87; 77/88; 77/89; 77/90; 77/91; 77/92; 77/93; 77/94; 77/95; 77/96; 77/97; 77/98; 77/99; 78/01; 78/02; 78/03; 78/04; 78/05; 78/06; 78/07; 78/08; 78/09; 78/10; 78/11; 78/12; 78/13; 78/14; 78/15; 78/16; 78/17; 78/18; 78/19; 78/20; 78/21; 78/22; 78/23; 78/24; 78/25; 78/26; 78/27; 78/28; 78/29; 78/30; 78/31; 78/32; 78/33; 78/34; 78/35; 78/36; 78/37; 78/38; 78/39; 78/40; 78/41; 78/42; 78/43; 78/44; 78/45; 78/46; 78/47; 78/48; 78/49; 78/50; 78/51; 78/52; 78/53; 78/54; 78/55; 78/56; 78/57; 78/58; 78/59; 78/60; 78/61; 78/62; 78/63; 78/64; 78/65; 78/66; 78/67; 78/68; 78/69; 78/70; 78/71; 78/72; 78/73; 78/74; 78/75; 78/76; 78/77; 78/78; 78/79; 78/80; 78/81; 78/82; 78/83; 78/84; 78/85; 78/86; 78/87; 78/88; 78/89; 78/90; 78/91; 78/92; 78/93; 78/94; 78/95; 78/96; 78/97; 78/98; 78/99; 79/01; 79/02; 79/03; 79/04; 79/05; 79/06; 79/07; 79/08; 79/09; 79/10; 79/11; 79/12; 79/13; 79/14; 79/15; 79/16; 79/17; 79/18; 79/19; 79/20; 79/21; 79/22; 79/23; 79/24; 79/25; 79/26; 79/27; 79/28; 79/29; 79/30; 79/31; 79/32; 79/33; 79/34; 79/35; 79/36; 79/37; 79/38; 79/39; 79/40; 79/41; 79/42; 79/43; 79/44; 79/45; 79/46; 79/47; 79/48; 79/49; 79/50; 79/51; 79/52; 79/53; 79/54; 79/55; 79/56; 79/57; 79/58; 79/59; 79/60; 79/61; 79/62; 79/63; 79/64; 79/65; 79/66; 79/67; 79/68; 79/69; 79/70; 79/71; 79/72; 79/73; 79/74; 79/75; 79/76; 79/77; 79/78; 79/79; 79/80; 79/81; 79/82; 79/83; 79/84; 79/85; 79/86; 79/87; 79/88; 79/89; 79/90; 79/91; 79/92; 79/93; 79/94; 79/95; 79/96; 79/97; 79/98; 79/99; 80/01; 80/02; 80/03; 80/04; 80/05; 80/06; 80/07; 80/08; 80/09; 80/10; 80/11; 80/12; 80/13; 80/14; 80/15; 80/16; 80/17; 80/18; 80/19; 80/20; 80/21; 80/22; 80/23; 80/24; 80/25; 80/26; 80/27; 80/28; 80/29; 80/30; 80/31; 80/32; 80/33; 80/34; 80/35; 80/36; 80/37;**

Introduction to the '388 Patent

- '388 patent describes a hybrid control strategy that reduces emissions during operation of the hybrid vehicle.
- The '388 patent describes a hybrid control strategy for limiting the rate of change of the engine torque output to a threshold value.
- When the rate of change of road load exceeds that threshold value, the '388 uses the electric motor to supply additional power to the wheels for propelling the vehicle.



(10) Patent No.: **US 7,104,347 B2**
 (45) Date of Patent: **Sep. 12, 2006**

FOREIGN PATENT DOCUMENTS

DE	10 097 535
DE	199 544 141
DE	19814602
DE	3 1998
EP	19338853
EP	01366655
EP	3 1985
EP	510582
EP	10 0992
EP	0 622 122
EP	5 1996
EP	0242311
EP	0769403
EP	4 1977

(Continued)

OTHER PUBLICATIONS

Simpulick, "Electric Vehicles", *Road & Track*, May 1992, pp. 126-129.

Reynolds, "AC Propulsion CRX", *Road & Track*, Oct. 1992, pp. 126-129.

Kalberlah, "Electric Hybrid Drive Systems . . .", SAE Paper No. 910247, 1991.

(Continued)

Primary Examiner—David R. Dunn
(74) Attorney, Agent, or Firm—Michael de Angelis

ABSTRACT

A hybrid vehicle comprises an internal combustion engine, a traction motor, a starter motor, and a battery bank, all controlled by a microprocessor in accordance with the present invention. The microprocessor is programmed to run only under conditions of high efficiency, typically only when the load is at least equal to 30% of the engine's maximum torque output. In some embodiments, a turbo-charger may be provided, activated only when the load is at least equal to 30% of the engine's maximum torque output. In some embodiments, an extended period, a two-speed transmission may further be provided, to further broaden the vehicle's load range. A hybrid brake system provides regenerative braking, with mechanical braking available in the event the battery bank is fully charged. In some embodiments, a torque converter transmission is provided to control the brake system to provide linear brake feel under varying circumstances.

41 Claims, 17 Drawing Sheets

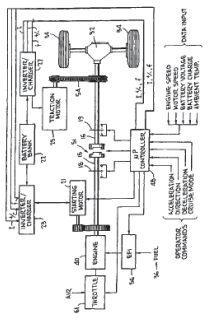

(12) **United States Patent**
 Severitsky et al.

(64) HYBRID VEHICLES

(75) Inventors: Alex J. Severitsky, Washington, DC (US); Theodore Lonetakes, Holly, MI (US)

(73) Assignee: Pace LLC, Boca Raton, FL (US)

(*) Notice: Subject to any disclaimer, the term of this patent is extended or adjusted under 35 U.S.C. 154(b) by 265 days.

(21) Appl. No.: 10082577
 (22) Filed: Mar. 7, 2003

Prior Publication Data
 US 2003/021876 A1 Nov. 27, 2003

Related U.S. Application Data

(60) Division of application No. 09/822,866, filed on Apr. 2, 2001, which is a continuation-in-part of application No. 09/392,743, filed on Sep. 26, 1999, which is a continuation-in-part of application No. 09/254,817, filed on Mar. 9, 1999, now Pat. No. 6,329,672.

(60) Division of application No. 60/132,286, filed on Mar. 1, 1999, and provisional application No. 60/100,075, filed on Sep. 14, 1998.

(31) Int. Cl. (2006.01)
B60K 6/02

(52) U.S. Cl. 180/65.2; 180/65.4; 701/54
 (53) Field of Classification Search 180/65.2; 180/65.3; 65.4; 65.8; 165; 60706; 711; 716; 60718; 20017; 40 R; 40 C; 32216; 4772; 701/54; 701/55; 701/54

See application file for complete search history.

References Cited

U.S. PATENT DOCUMENTS
 913,846 A 3/1959 Paper
 1,824,014 A 9/1931 Foshich
 2,666,692 A 1/1954 Sims et al.
 (Continued)

Introduction to the '388 Patent

'388 Patent, Ex. 1001 at Fig. 7

'388 Patent, Ex. 1001 at 38:55-39:19

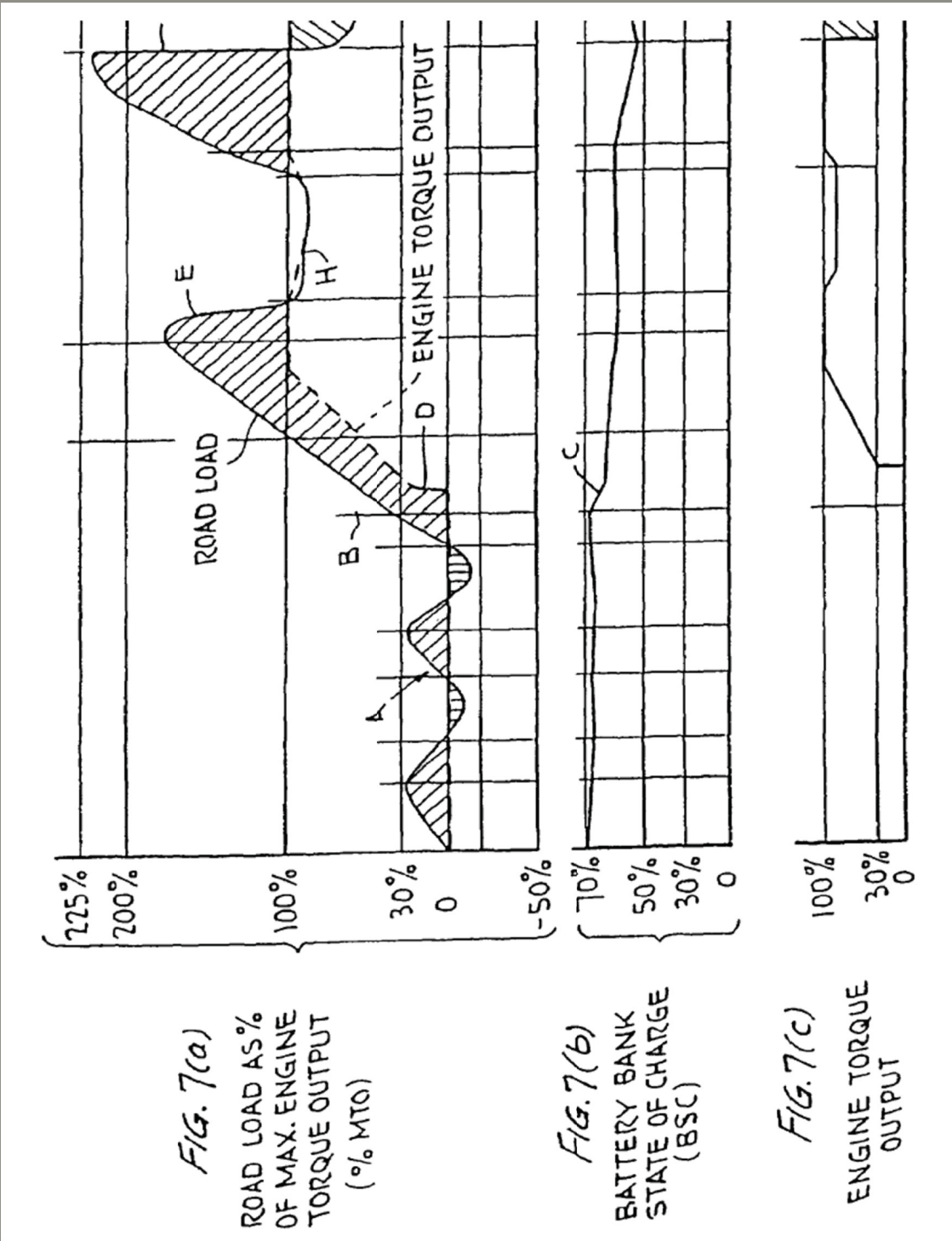

“The rate of change of the engine’s torque output is limited, e.g., to 2% or less per revolution, as indicated by noting that the dashed line in FIG. 7(a), indicating the instantaneous engine output torque, lags the solid line indicating the vehicle’s instantaneous torque requirement. Thus limiting the rate of change of engine output torque is preferred to limit undesirable emissions and improve fuel economy”

Introduction to the '388 Patent

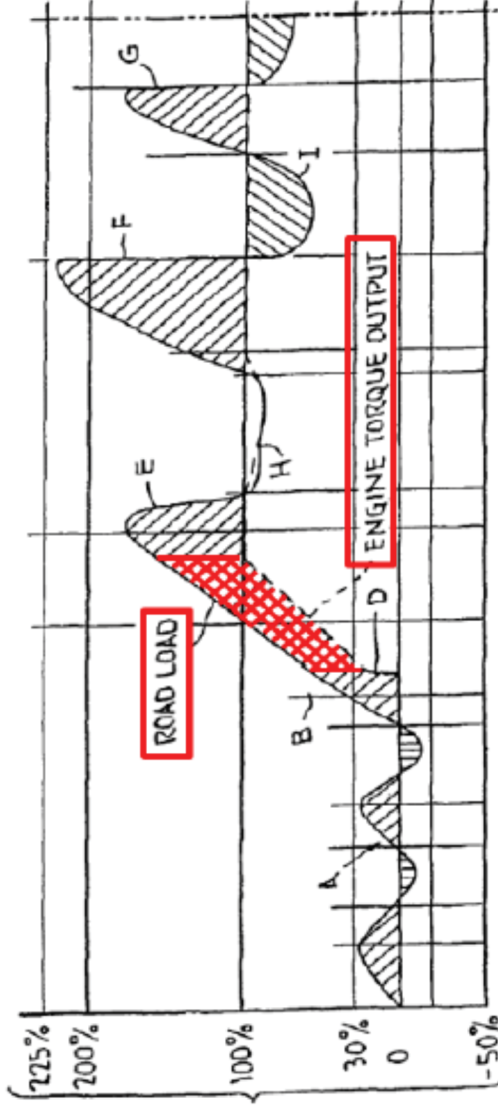

Fig. 7(a)
ROAD LOAD AS %
OF MAX. ENGINE
TORQUE OUTPUT
(% MTO)

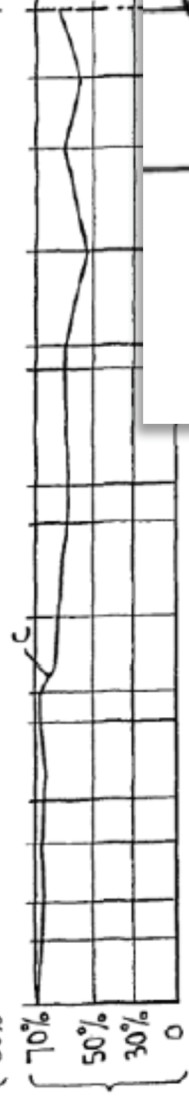

FIG. 7(b)
BATTERY BANK
STATE OF CHARGE
(BSC)



Fig. 7(c)
ENGINE TORQUE
OUTPUT

'388 Patent, Claim 1

wherein a rate of change of torque output of said engine is limited to a threshold value,

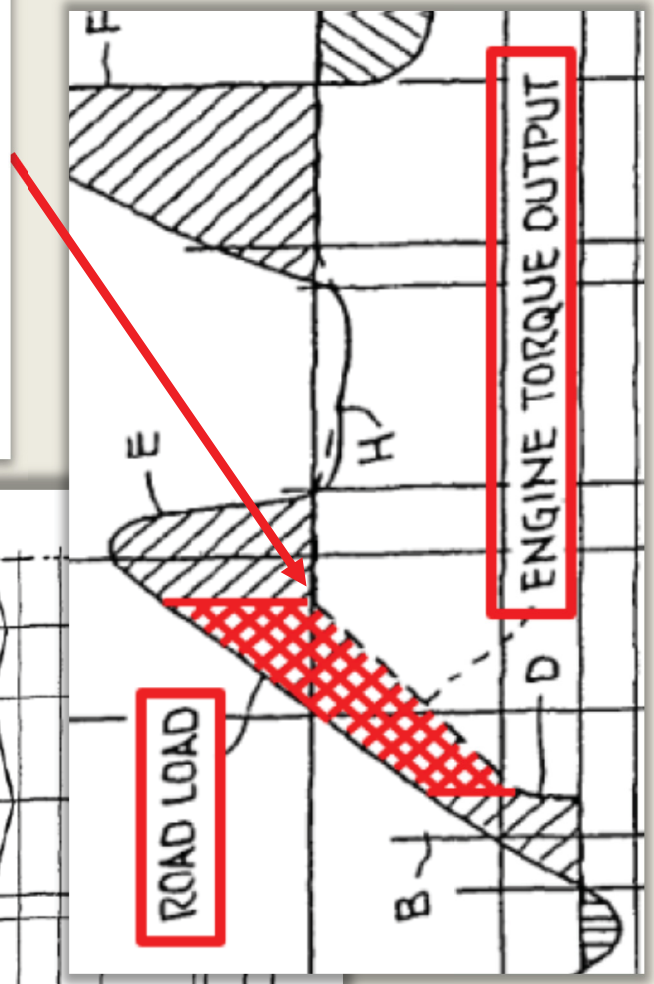

Introduction to the '388 Patent

'388 Patent, Claim 1

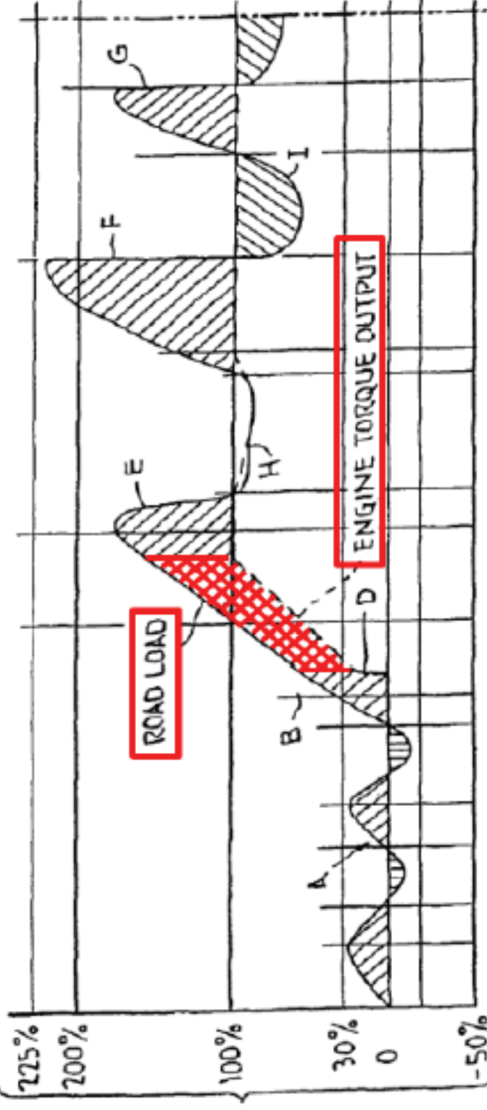

FIG. 7(a)
ROAD LOAD AS %
OF MAX. ENGINE
TORQUE OUTPUT
(% MTO)

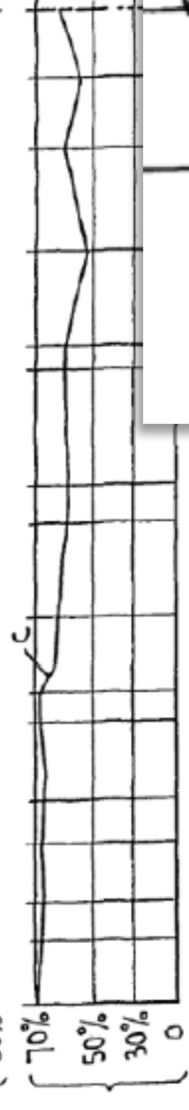

FIG. 7(b)
BATTERY BANK
STATE OF CHARGE
(BSC)

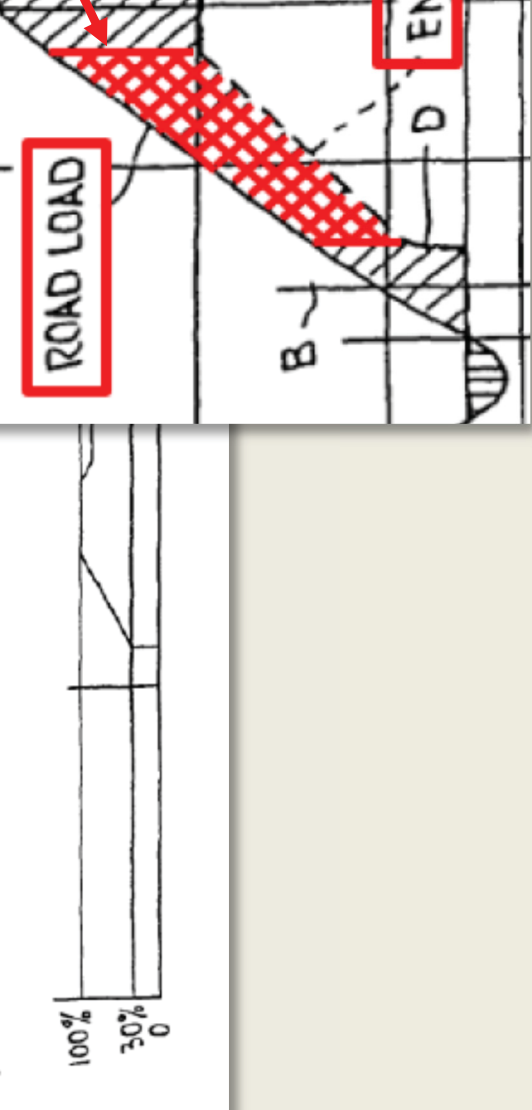

FIG. 7(c)
ENGINE TORQUE
OUTPUT

wherein when a rate of change of road load exceeds said threshold value of the rate of change of torque output of the engine, said controller is operable to operate said first motor and/or said second motor to supply additional power to at least said two wheels to supply remaining required torque.

FIAT CONCEPTUAL APPROACH TO HYBRID CARS DESIGN

Ing. Oreste Vittone
FIAT AUTO Engineering Department
C.so Sallustiana, 40
TORINO 10135

Ing. Filippo D'Aprile
Ing. Gianni Tomassere
FIAT RESEARCH CENTRE
Strada Torino, 50
Orbassano, TORINO 10043

Abstract

In this paper the different motivations behind the development of hybrid cars are examined and various hybrid configurations are illustrated which can satisfy a wide range of different and contrasting user needs. Specific attention is then given to the definition of guidelines for the development

of a hybrid car where parallel configuration of the propulsion system allows the fulfillment of two types of mission:

- short trips in urban areas with zero emissions by only using the electric motor driveline;
- long highway trips with performance close to that of conventional cars but lower emissions.

The corresponding design criteria for a Fiat medium size hybrid car are described together with the propulsion system, consisting of an A.C. electric motor and an ICE, that has been implemented and bench tested. A prototype car has also been equipped with this hybrid system and the driveability demonstrated.

The management of the two propulsion units: electric motor and ICE is performed via an ECU using suitable control logics to optimize, in terms of consumptions, emissions and battery energy management, the performance of the global system.

Introduction

In the last years the legislation scenario and the attention to the environmental issues have changed, also in relation with the inconceivable production by the traffic density in the most congested urban centers; as a consequence the research and development effort of the automotive and component manufacturers has changed, in order to better cope with the problems which did not allow up to now an industrial development of the environmental friendly electrically

458

● Vittone (Ex. 1005) is directed to a parallel hybrid architecture.

● “Vittone is directed to a parallel hybrid architecture, which uses the combination of an engine to propel the vehicle such that the respective torque and power are added on the same drive shaft to propel the vehicle.” POR at 13 .

United States Patent

[11] Patent Number: **5,586,613**
 [45] Date of Patent: **Dec. 24, 1996**

[54] **ELECTRICALLY PEAKING HYBRID SYSTEM AND METHOD**
 [75] Inventor: **Mehrdad Ehsani**, Bryan, Tex.
 [73] Assignee: **The Texas A&M University System**, College Station, Tex.

[21] Appl. No.: **312,438**
 [22] Filed: **Sep. 26, 1994**

Related U.S. Application Data
 [63] Continuation of Ser. No. 31,156, Apr. 22, 1993, abandoned.

[51] Int. Cl.⁶ **H01K 6/04**
 [52] U.S. Cl. **18065.2, 318/139**
 [58] Field of Search **18065.2, 318/139, 290/99, 18065.1, 65.2, 65.3, 65.4, 65.8, 318/139**

References Cited

3,693,666	2/1970	Doddy	180094
3,732,751	5/1973	Benman et al.	748575
3,791,475	2/1974	Rosen	180052
3,817,419	9/1974	Nakamura	180085
3,842,287	10/1974	Nakamura	290165
3,888,325	6/1975	Reuback	180065
3,923,115	12/1975	Hollings et al.	180065
4,042,656	8/1977	Hirawaki	180065
4,165,795	8/1979	Ljeth et al.	180065
4,187,241	2/1980	Nyano	240751
4,216,420	8/1980	Jinbo et al.	318/070

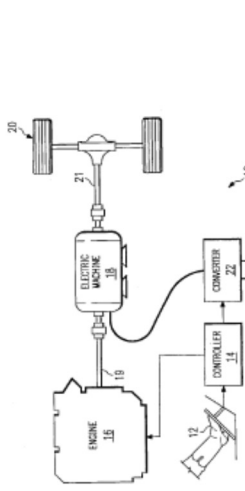

8 Claims, 3 Drawing Sheets

● **Ehsani (Ex. 1003) is directed to an electrically peaking hybrid (ELPH) vehicle**

● **“The term ‘peaking’ comes from the fact that the controller controls the system such that the electric machine delivers power to the drive shaft only at peak power requirements.” POR at 11 .**

Introduction to Kawakatsu

- Kawakatsu (Ex. 1004) discloses a hybrid vehicle that includes an engine coupled through a transmission or a clutch mechanism to a smaller DC motor/generator and a larger DC motor/generator.

- “Kawakatsu teaches using vehicle output shaft speed to operate the engine and to change operating modes.” POR at 16 .

United States Patent [19] **4,335,429**
Kawakatsu [45] Jun. 15, 1982

[54] CONTROL APPARATUS FOR ENGINE/ELECTRIC HYBRID VEHICLE
[73] Inventor: Shiro Kawakatsu, Seika, Japan
[72] Assignee: Daihatsu Motor Co., Ltd., Ikaeda, Japan

[21] Appl. No.: 129,718
[22] Filed: Mar. 12, 1980
[30] Foreign Application Priority Data
Mar. 20, 1979 [JP] Japan 54-34077
[51] Int. Cl. 2: B60K 1/00
[52] U.S. Cl.: 364/424, 426, 442, 364/426
[53] Field of Search: 364/424, 426, 442, 180/63 R, 65 A, 65 C, 123/72, 290/1 A

[56] References Cited
U.S. PATENT DOCUMENTS
3,861,484 1/1975 Jodin 180/63 A
3,933,115 12/1975 Helling 180/63 A
4,002,266 8/1977 Howland 180/63 A
4,097,333 6/1978 Wolf et al. 180/63 A

26 Claims, 27 Drawing Figures

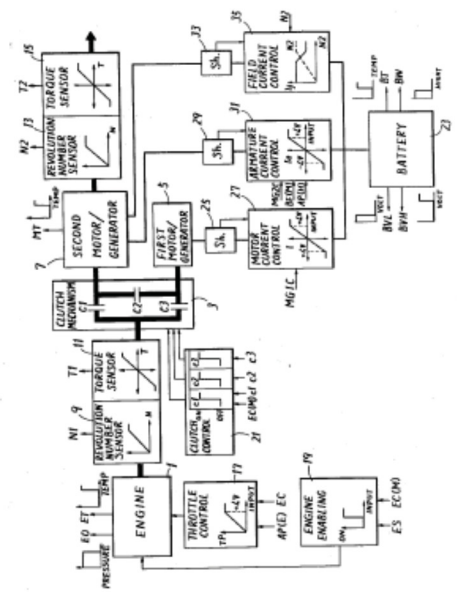

FORD 1004

Page 1 of 35

Grounds 1 and 5: Vittone does not disclose limiting the rate of change of engine output torque

Ground 1 and 5 are defective: Vittono does not disclose limiting the rate of change claim elements

Claim 1:

wherein a rate of change of torque output of said engine is limited to a threshold value, wherein when a rate of change of road load exceeds said threshold value of the rate of change of torque output of the engine, said controller is operable to operate said first motor and/or said second motor to supply additional power to at least said two wheels to supply remaining required torque.

Claim 19:

limiting a rate of change of torque output of the engine to a threshold value; and
operating the first and/or the second AC electric motors to supply additional power to the at least two wheels to supply remaining required torque when a rate of change of road load exceeds the threshold value of the rate of change of torque output of the engine.

Ground 1 and 5 are defective: Vittone does not disclose limiting the rate of change claim elements

- **Vittone does not disclose the claim limitations: (POR at 22)**
 - **“Vittone does not disclose ‘road load.’” POR at 22 .**
 - **“Vittone does not disclose limiting a rate of change of engine torque to a threshold value.” POR at 28 .**

Ground 1 and 5 are defective: Vittone does not disclose limiting the rate of change claim elements

- Vittone does not disclose the claim limitations: (POR at 22)
- **“Vittone does not disclose ‘road load.’” POR at 22.**
- **“Vittone does not disclose limiting a rate of change of engine torque to a threshold value.” POR at 28.**

Vittone does not disclose “road load”

Vittone, Ex. 1005 at 26

The driver, through the accelerator pedal position, sets the total traction torque; this is splitted between the two drivelines in such a way to meet the following objectives:

Vittone discloses using pedal position

Vittone, Ex. 1005 at 26

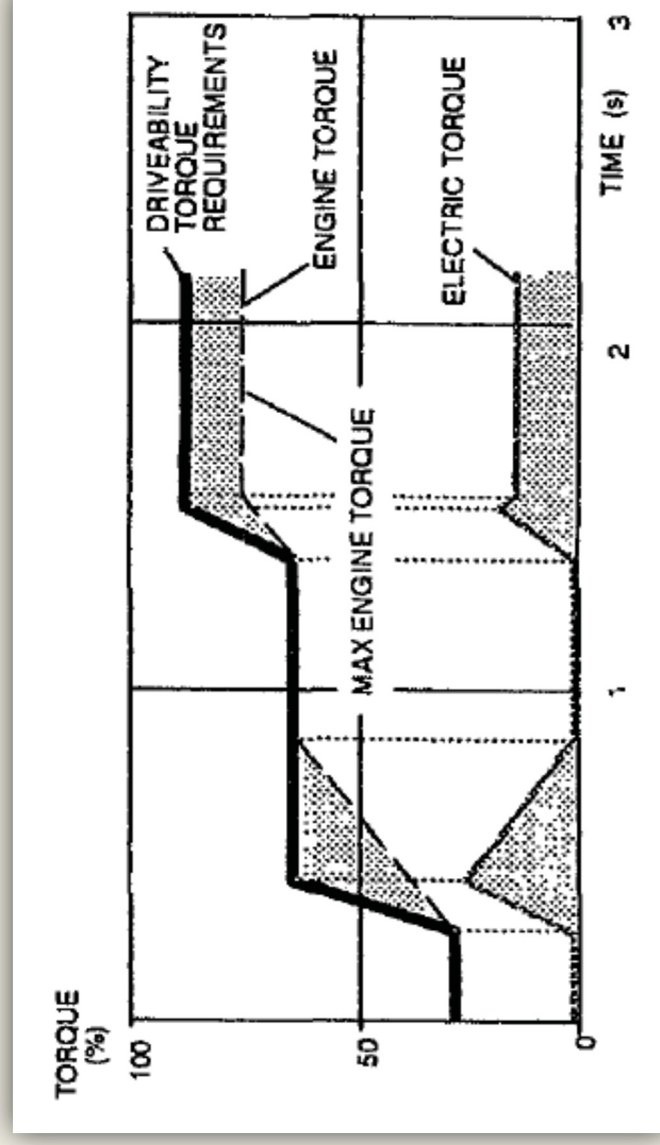

“Vittone defines the ‘driveability torque requirement’ according to the accelerator pedal position, which is scaled in relationship to the combined torque output of the motor and the engine (the internal power sources). Road load, on the other hand, takes into account external torque requirements such as driving conditions.”

IPR ‘875, Paper 19, POR at 27, (citing Ex. 2003 at ¶72-73).

Vittone discloses using pedal position



In hybrid vehicle systems like Vittone that use accelerator pedal position, 100% pedal position was associated with the combined torque output of the motor and the engine, *i.e.* 100% pedal position was associated with 100% “total traction torque.” That Vittone applies this conventional method of measuring pedal position is confirmed by Vittone’s disclosure that “the thermal engine is controlled through the DRIVE-BY-WIRE system.” Ex. 1005 at 26. A DRIVE-BY-WIRE system is a system that performs electronically what a conventional system performed mechanically.

Vittone, Ex. 1005 at 26.

In the hybrid mode, both electric motor and thermal engine are “active”; the thermal engine is controlled through the DRIVE-BY-WIRE system.

Vittone discloses using pedal position



When the driver holds the pedal at the same position, there is no change in pedal position, which is reflected by the flat portions of the line

shown in Figure 8. When the driver presses on the pedal to accelerate, the change in pedal position is reflected by the sloped portions of the line. The “step function” shape of the driveability torque requirement line reflects the changes in pedal position.

Vittone, Ex. 1005 at 30

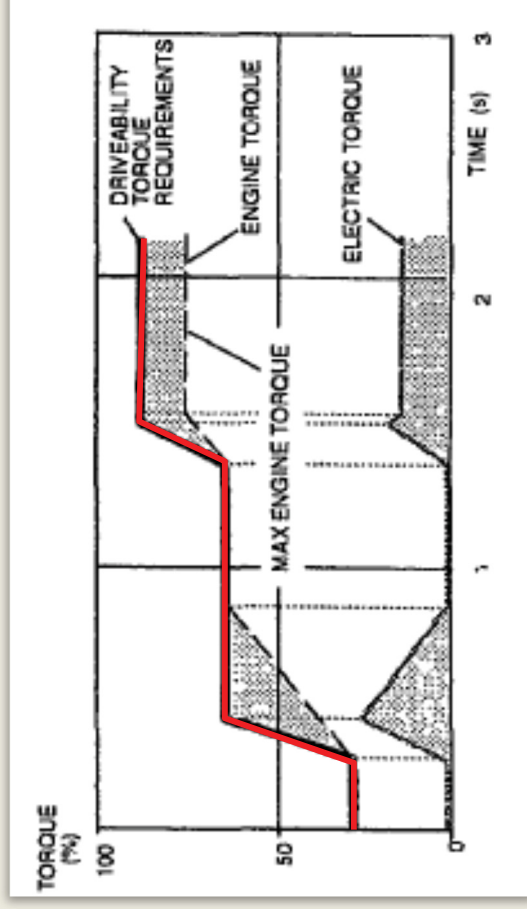

Vittone does not disclose “road load”



“So this is how Vittone determines the -- in his system, how the -- an estimate of the torque requirements to propel the vehicle is determined, and then is used by the subsequent optimal power management and torque management system to utilize the engine and the electric motor for propelling the vehicle.”

Ex. 2007, Stein Tr. at 117:14-118:14.

Ground 1 and 5 are defective: Vittone does not disclose limiting the rate of change claim elements

- Vittone does not disclose the claim limitations: (POR at 22)
- “Vittone does not disclose ‘road load.’” POR at 22.
- “Vittone does not disclose limiting a rate of change of engine torque to a threshold value.” POR at 28.

Vittone does not disclose limiting the rate of change of engine torque

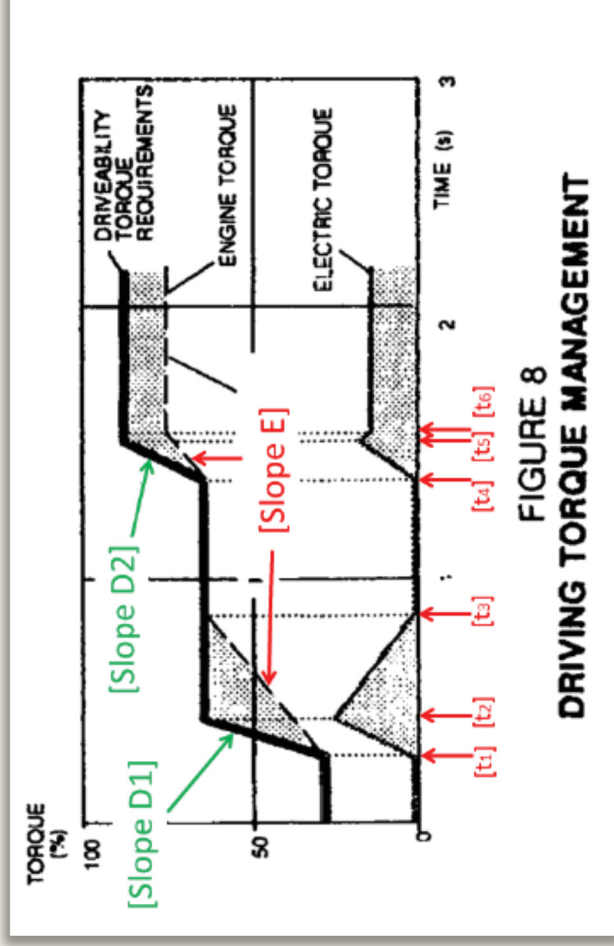

FIGURE 8
DRIVING TORQUE MANAGEMENT

Stein Dec., Ex. 1002 at 80-81.

“I have confirmed that Slope D1 is greater than Slope D2. This means that the “rate of change of road load” is greater during the first transient phase than during the second transient phase. However, the slope of the ENGINE TORQUE curve (i.e., the “rate of change of torque output of the engine”) is approximately equal to a common value during both transient phases (i.e., SlopeE).”

Vittone does not disclose limiting the rate of change of engine torque

- “Figure 8 is not drawn to scale, nor are the slopes meant to be accurate and precise.” POR at 29.



Hannemann Dec., Ex. 2003 at 38

Slope is defined as the ratio of the change in y-axis to the change in x-axis. In Vittone, the x-axis measures 2.3 cm between 0-1 seconds, 2.5 cm between 1-2 seconds, and 2.0 cm between 2-3 seconds. In Dr. Stein’s enlarged annotated version, the x-axis measures 4.2 cm between 0-1 seconds, 4.8 cm between 1-2 seconds, and 4.0 cm between 2-3 seconds.

Vittone does not disclose limiting the rate of change of engine torque

- “Vittone does not explain what is meant for “steady state” management of the thermal engine or how that is accomplished.” POR at 31.



Hannemann Dec., Ex. 2003 at 39

Figure 8 is a representation of how the total traction torque is split between the engine and electric motor, it does not specify the management strategy of the IC engine. Engines have inherent transient characteristics, and there is no disclosure in Vittone that Figure 8 shows the controller limiting the rate of change of engine output torque or limiting the rate of change of engine output torque to a threshold value, rather than simply showing the ramp-up of the engine due to its inherent transient characteristics.

Fig. 8 does not disclose limiting the rate of change of engine output torque

- “Dr. Stein testified that an engine in a conventional vehicle cannot respond instantly to a driver’s request for acceleration.” Motion for Observations at 3.



Q. All right. So the driver has called for rapid acceleration. You agree in order to meet the demand in the rented Optima, the engine is going to have to go from producing the certain small amount of power when you were stopped and idling to a much larger amount of power; is that fair?

A. It will start producing more power as a result of depressing the pedal, that is correct. The engine will begin to produce more power but not instantly.

- This testimony “shows that contrary to Dr. Stein’s opinion, Fig. 8 of Vittone would still show the ‘engine output torque’ lagging behind ‘the driveability torque requirement’ in a conventional vehicle where the engine output torque was not being limited.” Motion for Observations at 3.

Fig. 8 does not disclose limiting the rate of change of engine output torque



Q. So when you say without any limit on the torque, it's possible that could follow the drivability torque requirements, are you suggesting that the dotted line would simply overlap the drivability torque requirement line?

A. I said without any limit on the increase in engine torque output and the rate of change of the engine torque output, it's possible that the engine torque might be able to rise at the rate that this particular figure illustrates for the torque required to propel the vehicle. And if that were the case, then the dotted line would track over the thick black line.

Q. What if that were not the case?

A. Then it would lag behind a certain amount, but I would expect that lagging behind to -- the details of that response would not, in general, be a straight line.

Vittone's "steady state management" does not disclose limiting the rate of change of engine torque

- "The 'steady state' management of the engine in transient phases could be accomplished in many ways, such as limiting throttle plate angle, engine speed, or engine output power." POR at 31.

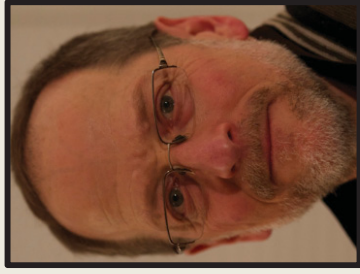

Q. Just generally, what are the different ways for maintaining steady state management in an engine?

MR. ANGILERI: Objection, vague.

A. As I was talking about before, you have a variety of inputs to the engine whether it's throttle, injection or injectors where you have the injection, the timing, and you have the injection duration and you have air flow control, which is partly what happens in throttle control, and you have different inputs that you can control, and these can be used in combinations with different control strategies to different effects. And so I don't -- I mean the whole reason for having these different inputs and control of these inputs is to be able to, as an automotive engineer, as a controls engineer, is to then be able to affect the performance in a way that is consistent with your objectives.

Grounds 1 and 5: A POSITA Would Not Combine Vittone with Ehsani or Kawakatsu

Ford has failed to identify a sufficient motivation to combine

- “Ford asserts that it would have been obvious to modify the Ehsani engine control strategy to include the engine control strategies taught by Vittone for the purpose of optimizing fuel economy and reducing emissions” POR at 32.

Petition, Paper No. 1, at 35

Both [Ehsani and Vittone] are directed to improving fuel efficiency and emissions using a parallel HEV architecture.

Ford has failed to identify a sufficient motivation to combine

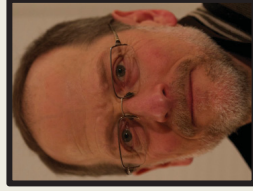

Q. I think you may have just answered my question, Dr. Stein, because it sounds like what you're saying is that unless you look specifically at the references, the mere fact that both references might be concerned with reducing emissions and increasing fuel economy is not sufficient in and of itself to combine the two references, right?

MR. TURNER: Objection to the extent it mischaracterizes earlier testimony.

A. Yeah, I said that -- I said that that is certainly a good motivation for combining references, but it may not be the only motivation and --

Q. Is it a sufficient motivation, sir?

MR. TURNER: Objection. Vague.

A. I guess that I would have to again ask us to look at the combination of two specific references and look at the criteria that I've used and --

Q. So you can't answer the question without specifically looking at the two references then?

A. As to what would be a sufficient motivation for those specific references to make some kind of assessment of what would be a rationale to combine those two references.

Grounds 1 and 5: Vittone Does Not Render Obvious Claim 3

'388 Patent Claim 3 Introduction

Claim 1

a controller;
wherein a rate of change of torque output of said engine is limited to a threshold value. wherein when a rate of change of road load exceeds said threshold value of the rate of change of torque output of the engine, said controller is operable to operate said first motor and/or said second motor to supply additional power to at least said two wheels to supply remaining required torque.

Claim 3

3. The hybrid vehicle of claim 1, wherein said controller is operable to vary said threshold value with respect to a state of charge of said electrical storage device.

Claim 3 varies the threshold value of claim 1 according to the battery state of charge

Vittone does not disclose claim 3

- Ford relies on Vittone’s disclosure that “[d]epending on the state of charge of the batteries . . . the control system allows also to introduce only the electric traction in the phases in which the thermal engine would be required to work in low efficiency conditions.” See POR at 37-38 (citing Ex. 1005 at 26).
- “Dr. Stein testified that the only support for his opinion that Vittone renders obvious claim 3 of the ’388 patent was ‘recognition of the state of charge of the battery being important to implementing its use of electricity to manage the hybrid electric vehicle.’” See IPR ‘875, Paper No. 28, Motion for Observations at 4 (citing Ex. 2009, Stein Tr. at 63:16-66:6).

Ground 2: Caraceni Does Not Render Obvious Claim 2

'388 Patent Claim 2 Introduction

Claim 1

a controller;
wherein a rate of change of torque output of said engine is limited to a threshold value. wherein when a rate of change of road load exceeds said threshold value of the rate of change of torque output of the engine, said controller is operable to operate said first motor and/or said second motor to supply additional power to at least said two wheels to supply remaining required torque.

Claim 2

2. The hybrid vehicle of claim 1, wherein said threshold value is no more than about 2% per revolution.

Claim 2 limits the threshold value of claim 1 to a 2% increase per revolution

981124

HYBRID POWER UNIT DEVELOPMENT FOR FIAT MULTIPLA VEHICLE

A. Caraceni, G. Cipolla
ELASIS S.p.A. - Milano

R. Barbiero
FIAT AUTO - VAMIA

Copyright © 1998 Society of Automotive Engineers, Inc.

ABSTRACT

In the "scenario" of increasing concerns for environmental pollution, hybrid vehicles will play a significant role in the near future. Compared to electric vehicles, the hybrid ones have an unrestricted driving range, higher performance and transport capability, still fulfilling ZEV emission regulation.

The hybrid vehicle features a power train that integrates a thermal engine with an electric motor. Among the several possible configurations for hybrid vehicle, the parallel hybrid one has been chosen for the FIAT MULTIPLA, for the following reasons:

- lower weight and volume of the electric unit to obtain the same driving mission;
- higher global efficiency of the system, due to direct thermal to mechanical energy conversion;
- a better vehicle performance (acceleration and max speed), thanks to the contribution of both motors to traction.

In the development of a hybrid parallel concept, the critical aspects to be overcome are related to the system mechanical complexity and the simultaneous control of the two motors.

In this paper the Fiat Auto and Elasis approach to the hybrid vehicle is presented with particular reference to the powertrain unit and its control strategies.

INTRODUCTION

In the last years the European legislation and environmental issues have focused the attention to the incongruent energy consumption by traffic density in our most

congested European urban centers. Electric vehicles, as reported by several studies performed in different European cities, could substitute less than 10 % of the vehicles in circulation in the cities, provided that they can assure a real range of more than 60 km. On the contrary hybrid vehicle would allow a substitution of a bigger portion of the vehicle city park, thanks to their "range extension" and "peak performance" features.

The hybrid vehicle seems to be a very promising answer to today's different demands such as:

- free driving in emission protected zones
- ability to match different condition in urban or extra urban driving
- unrestricted range and transport capabilities like thermal vehicles
- same or similar driving characteristics as a conventional vehicle
- reduced dependency on batteries
- use of existing infrastructure
- commercially interesting image.

The mass production feasibility of the electric vehicle remains nowadays a big concern, primarily because of the battery problems. In case of the hybrid vehicle, battery dependency is reduced and so the hybrid vehicle is more acceptable to the public.

Conventional vehicles, especially those equipped with gasoline engines, have lower fuel economy and higher emissions, especially in short range distance driving during warm-up phases, but offer high performance. **FORD 1906**

29

Caraceni (Ex. 1006) describes the hybrid Fiat Multipla, a parallel hybrid vehicle with an engine and a single traction motor

Ground 2 is defective because Caraceni does not disclose the claim limitation

- Ford and Dr. Stein rely on Caraceni’s disclosure of absolute torque gradients for claim 2’s limitation, “wherein said threshold value is no more than about 2% per revolution.” See POR at 40-41.
- Dr. Stein’s analysis of Caraceni with respect to claim 2 is contrary to the clear language, which recites a *percent* increase from one revolution to the next, not the fixed “absolute” rate of change disclosed by Caraceni. See *id.* at 39-40 (citing Ex. 2003 at ¶ 94).

Ground 2 is defective because Caraceni does not disclose the claim limitation

- **Mr. Hannemann has explained the important differences between absolute and relative thresholds:**



Hannemann Dec., Ex. 2003 at 94

Using Caraceni's 1 deca-Newton Meter per second as disclosed by Figs. 12 and 13, going from zero torque to Caraceni's engine's maximum torque of 115 Nm would take 11.5 seconds, regardless of the engine speed. ... an increase for 10 Nm to 115 Nm at 1 deca-Newton Meter per second would take 10.5 seconds and an increase from 50 Nm to 115 Nm would take 6.5 seconds.

Conversely, using the '388 patent's 2% per revolution threshold, assuming a starting torque of 10 Nm and an engine speed of 1000 rpm it would take 7.44 seconds to achieve the maximum torque of 115 Nm. If the starting torque were 50 Nm and the engine speed were 1000 rpm it would take 2.76 seconds to achieve the maximum torque. Increasing the engine speed to 6000 rpm for the 50 Nm starting point results in .46 seconds to reach maximum torque.

Ground 2 is defective because Caraceni does not disclose the claim limitation

- Dr. Stein was unable to explain during his deposition why a POSITA would modify Caraceni's absolute threshold to use a "relative" threshold as required by the claims:

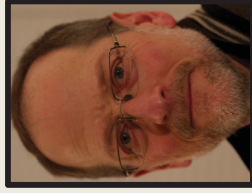

Q. And my question, Dr. Stein, is: Given the difficulties that you mentioned in your earlier testimony and the fact that you've stated that the relative change threshold is inferior to an absolute threshold, why would a person of skill in the art be motivated to modify Caraceni's absolute torque gradient according to the examples that you've provided?

MR. TURNER: Objection. Foundation.

A. I don't really understand what you're asking. It seems like you're asking me to guess on what a person of ordinary skill might or might not specifically do...

Ground 3: A POSITA Would Not Have Combined Ehsani and Fjallstrom

- Fjallstrom (Ex. 1007) is directed to a vehicle transmission system for driving the drive shafts of a vehicle continuously at variable speed.
- The transmission includes DC electric motor/generators and planetary gear means.

United States Patent [19] 4,335,429
Kawakatsu [45] Jun. 15, 1982

[54] CONTROL APPARATUS FOR ENGINE/ELECTRIC HYBRID VEHICLE
[73] Inventor: Shiro Kawakatsu, Seika, Japan
[72] Assignee: Daihatsu Motor Co., Ltd., Ikaeda, Japan

[21] Appl. No.: 129,718
[22] Filed: Mar. 12, 1980
[30] Foreign Application Priority Data
Mar. 20, 1979 [JP] Japan 54-34077
[51] Int. Cl. 2: B60K 1/00
[52] U.S. Cl.: 364/424, 364/426, 364/428
[53] Field of Search: 364/424, 426, 442, 180/63 R, 65 A, 65 C, 123/2, 200/1 A

[56] References Cited
U.S. PATENT DOCUMENTS
3,861,484 1/1975 Jodin 180/63 A
3,933,115 12/1975 Helling 180/63 A
4,002,266 8/1977 Howland 180/63 A
4,097,333 6/1978 Wolf et al. 180/63 A

26 Claims, 27 Drawing Figures

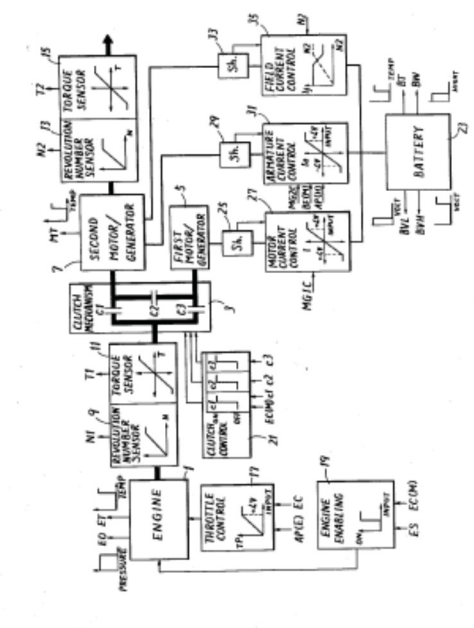

Ground 3 is defective because a POSITA would not combine Ehsani and Fjallstrom

- A POSITA would not have combined Ehsani with Fjallstrom to provide an AWD hybrid vehicle because Ehsani already discloses an alternative embodiment of an AWD hybrid vehicle. See POR at 43 (citing Ex. 2003 at ¶101, and *Fluor Tec, Corp. v. Kappos*, 2012 WL 6135201 at **4 (Fed. Cir. 2012) (unpublished)).
- A POSITA would also not be motivated to use Fjallstrom's DC motors with Ehsani's AC motors. See POR at 43 (citing to Ex. 2003 at ¶102).

Ground 4: Yamaguchi Does Not Render Obvious Claim 12

'388 Patent Claim 12 Introduction

12. The hybrid vehicle of claim 1, wherein said engine is preheated prior to starting.

Ground 4 is defective

- Yamaguchi merely discloses that the engine is started when the engine temperature has reached a predetermined value. See POR at 46 (citing to Ex. 2003 at ¶ 104).
- Nothing in Yamaguchi discloses that the engine is preheated or that the engine temperature or predetermined value is sufficient to preheat the engine. See *id.*
- Additionally, a POSITA would not have combined Yamaguchi, Ehsani, and Vittono, because Vittono discloses that to reduce emissions, the vehicle has a heated catalyst, by which the warm-up of the main catalyst is performed, while the engine works at a minimum rpm. See *id.* at 47.

END