



US005343970A

# United States Patent [19]

[11] Patent Number: **5,343,970**

Severinsky

[45] Date of Patent: **Sep. 6, 1994**

- [54] **HYBRID ELECTRIC VEHICLE**
- [76] Inventor: **Alex J. Severinsky**, 10904 Pebble Run, Silver Spring, Md. 20902
- [21] Appl. No.: **947,691**
- [22] Filed: **Sep. 21, 1992**
- [51] Int. Cl.<sup>5</sup> ..... **B60K 6/04**
- [52] U.S. Cl. .... **180/65.2; 180/65.6; 180/165; 60/718; 475/2; 475/5**
- [58] Field of Search ..... **180/65.2, 65.3, 65.4, 180/65.6, 165; 60/716, 718; 475/2, 5, 8, 9**

- 4,593,779 6/1986 Kröhling ..... 180/65.4
- 4,611,466 9/1986 Keedy ..... 60/718
- 4,697,660 10/1987 Wu et al. .... 180/65.2
- 4,815,334 3/1989 Lexen ..... 74/661
- 4,923,025 5/1990 Ellers ..... 180/65.2
- 4,951,769 8/1990 Kawamura ..... 180/65.4
- 5,053,632 10/1991 Suzuki et al. .... 180/65.2
- 5,117,931 6/1992 Nishida ..... 180/65.2
- 5,120,282 6/1992 Fjallstrom ..... 180/65.4 X

### [56] References Cited

#### U.S. PATENT DOCUMENTS

3,525,874	8/1970	Toy	180/65.2
3,566,717	3/1971	Berman et al.	180/65.2
3,650,345	3/1972	Yardney	180/65.2
3,732,751	5/1973	Berman et al.	180/65.2
3,791,473	2/1974	Rosen	180/65.2
3,837,419	9/1974	Nakamura	180/65.4
3,874,472	4/1975	Deane	180/65.4
3,923,115	12/1975	Helling	180/65.2
4,042,056	8/1977	Horwinski	180/65.2
4,095,664	6/1978	Bray	180/65.4
4,148,192	4/1979	Cummings	180/65.2
4,180,138	12/1979	Shea	180/65.2
4,269,280	5/1981	Rosen	180/65.2
4,305,254	12/1981	Kawakatsu et al.	180/65.2
4,306,156	12/1981	Monaco et al.	180/65.2
4,313,080	1/1982	Park	180/65.2
4,335,429	6/1982	Kawakatsu	180/65.2
4,351,405	9/1982	Fields et al.	180/65.2
4,354,144	10/1982	McCarthy	180/65.4
4,400,997	8/1983	Fiala	180/65.2
4,405,029	9/1983	Hunt	180/65.2
4,407,132	10/1983	Kawakatsu et al.	180/65.4
4,438,342	3/1984	Kenyon	180/65.2
4,439,989	4/1984	Yamakawa	60/718
4,470,476	9/1984	Hunt	180/65.2
4,533,011	8/1985	Heidemeyer et al.	180/65.2
4,562,894	1/1986	Yang	180/65.2
4,578,955	4/1986	Medina	180/65.4

### OTHER PUBLICATIONS

- SAE Technical Paper Series 891659, Bullock, pp. 11-26, Aug. 7-10, 1989.
- SAE Technical Paper Series 910247, Kalberlah, pp. 69-78, Feb. 25-Mar. 1, 1991.

Primary Examiner—Margaret A. Focarino

Assistant Examiner—Peter C. English

### [57] ABSTRACT

An improved hybrid electric vehicle includes an internal combustion engine and an electric motor. Both the motor and the engine provide torque to drive the vehicle directly through a controllable torque transfer unit. Typically at low speeds or in traffic, the electric motor alone drives the vehicle, using power stored in batteries; under acceleration and during hill climbing both the engine and the motor provide torque to drive the vehicle; and in steady state highway cruising, the internal combustion engine alone drives the vehicle. The internal combustion engine is sized to operate at or near its maximum fuel efficiency during highway cruising. The motor is operable as a generator to charge the batteries as needed and also for regenerative braking. No transmission is employed. The motor operates at significantly lower currents and higher voltages than conventionally and has a rated power at least equal to that of the internal combustion engine. In this manner a cost efficient vehicle is provided, suffering no performance disadvantage compared to conventional vehicles.

40 Claims, 12 Drawing Sheets

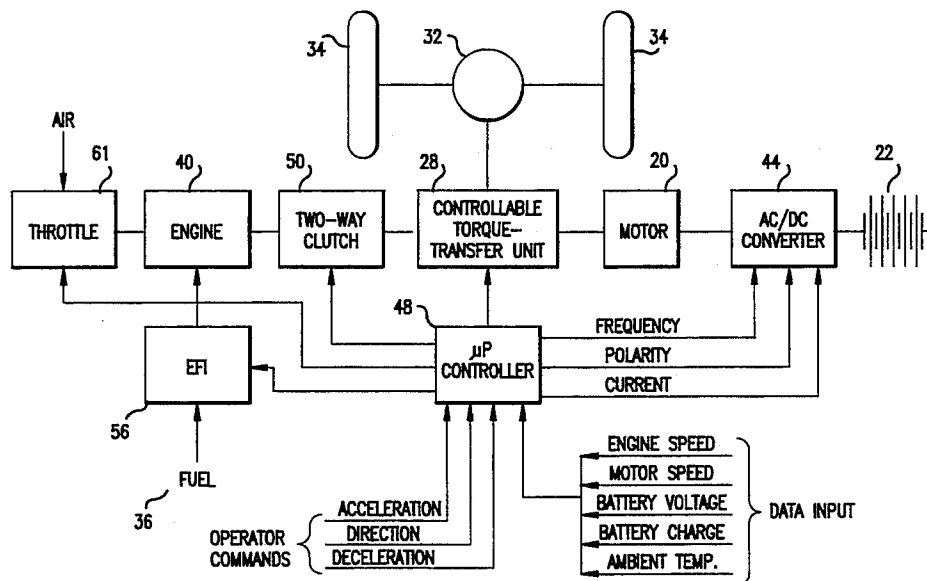

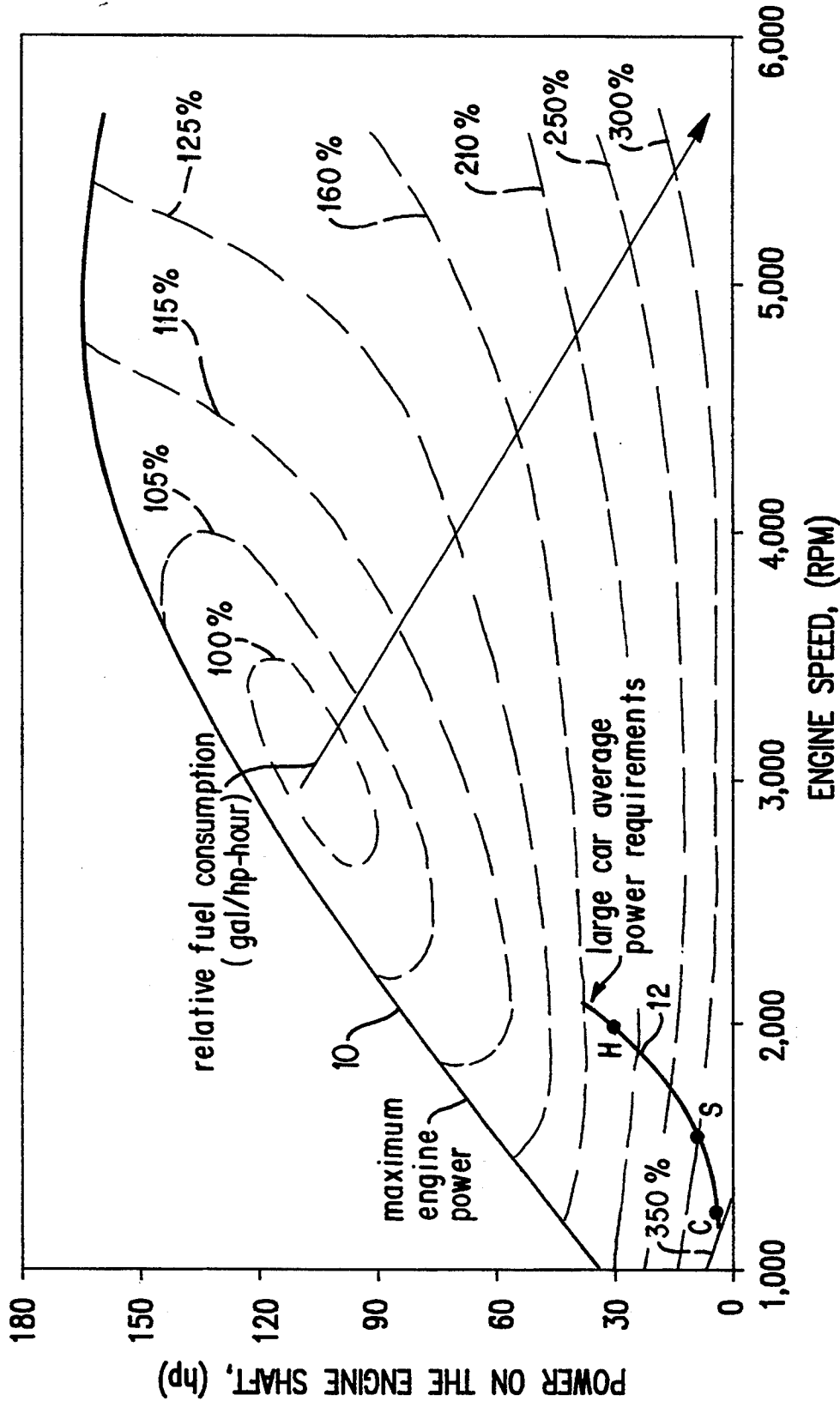

FIG. 1  
(PRIOR ART)

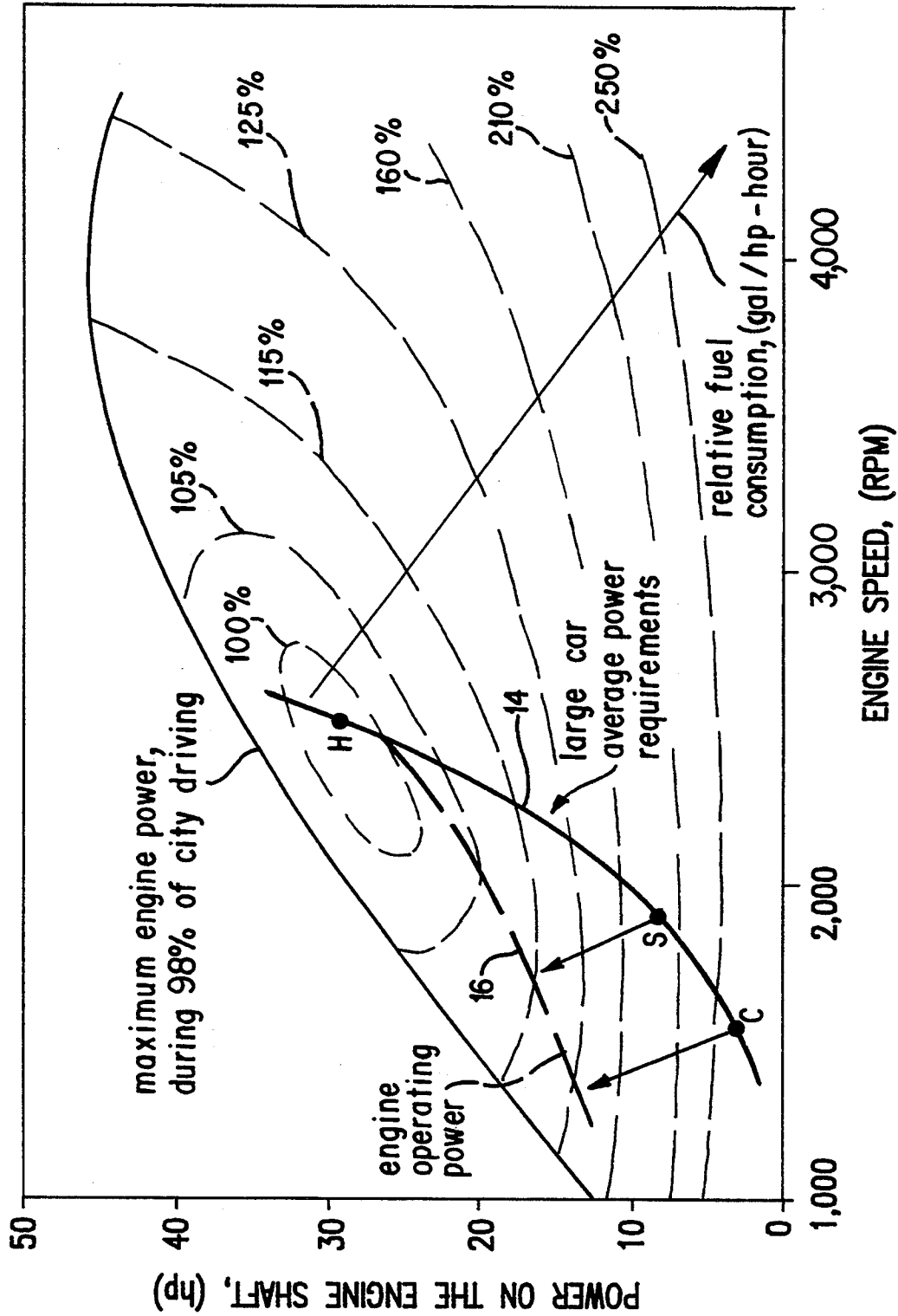

FIG. 2

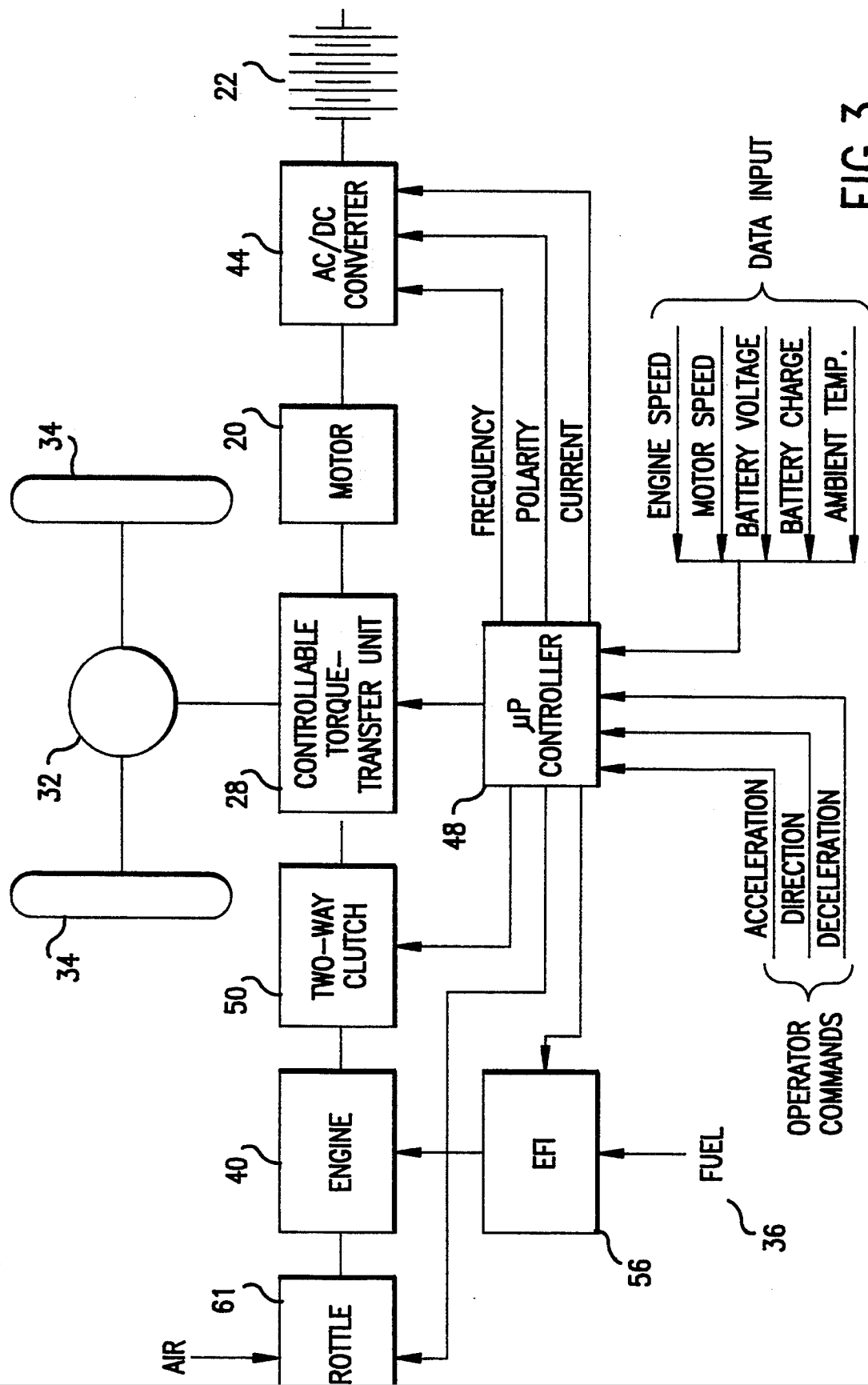

FIG. 3



# Explore Litigation Insights

Docket Alarm provides insights to develop a more informed litigation strategy and the peace of mind of knowing you're on top of things.

## Real-Time Litigation Alerts



Keep your litigation team up-to-date with **real-time alerts** and advanced team management tools built for the enterprise, all while greatly reducing PACER spend.

Our comprehensive service means we can handle Federal, State, and Administrative courts across the country.

## Advanced Docket Research



With over 230 million records, Docket Alarm's cloud-native docket research platform finds what other services can't. Coverage includes Federal, State, plus PTAB, TTAB, ITC and NLRB decisions, all in one place.

Identify arguments that have been successful in the past with full text, pinpoint searching. Link to case law cited within any court document via Fastcase.

## Analytics At Your Fingertips



Learn what happened the last time a particular judge, opposing counsel or company faced cases similar to yours.

Advanced out-of-the-box PTAB and TTAB analytics are always at your fingertips.

## API

Docket Alarm offers a powerful API (application programming interface) to developers that want to integrate case filings into their apps.

## LAW FIRMS

Build custom dashboards for your attorneys and clients with live data direct from the court.

Automate many repetitive legal tasks like conflict checks, document management, and marketing.

## FINANCIAL INSTITUTIONS

Litigation and bankruptcy checks for companies and debtors.

## E-DISCOVERY AND LEGAL VENDORS

Sync your system to PACER to automate legal marketing.