

050806



16698 U.S. PTO

IN THE UNITED STATES PATENT AND TRADEMARK OFFICE

RULE 60 APPLICATION

113000 U.S. PTO  
11/429457



050806

Atty. Dkt. PAICE201.DIV.3

Hon. Commissioner for Patents  
P.O. Box 1450  
Alexandria, VA 22313-1450

Sir:

This is a request for filing a **divisional** application under 37 CFR § 1.60 of pending prior application Serial No. 10/382,577 filed on March 7, 2003 entitled Hybrid Vehicles

Full Name of first joint inventor: Alex J. Severinsky

Residence: Washington, D.C. Citizenship: U.S.

Post Office Address: 4704 Foxhall Crescent, Washington D. C. 20007

Full Name of second joint inventor: Theodore Louckes

Residence: Holly, Michigan Citizenship: U.S.

Post Office Address: 10398 Appomattox, Holly, MI 48442

Enclosed is a copy of the prior application as originally filed. I hereby verify that the attached papers are a true copy of the prior application Serial No. 10/382,577 as originally filed on March 7, 2003.

The filing fee is calculated below: Claims as filed, less any claims canceled:

						LARGE ENTITY	
CLAIMS				Basic Filing Fee:		\$ 300	
Total	62	-	20	=	42	x \$50	\$2100
Indep.	3	-	3	=	0	x \$200	<u>\$ 0</u>
Search fee							\$500

Examination fee	\$200
Size fee (110 sheets text, 17 sheets of drawing)	\$500
	<hr/> <hr/>
Total Fee	\$3600

\_\_\_ The Commissioner is hereby authorized to charge fees under 37 CFR § 1.16 and § 1.17 which may be required, or credit any overpayment of Deposit Account No. 04-0401. A duplicate copy of this sheet is enclosed.

\_\_\_ Status as a "small entity" under 37 CFR 1.9 is claimed by way of the attached declaration.

X A preliminary amendment is enclosed.

\_\_\_ An information disclosure statement is enclosed.

X Cancel the following claims before calculating the filing fee:  
1 - 16.

X The filing fee will be paid in response to a Notice of Missing Parts.

\_\_\_ Priority of application Serial No. \_\_\_\_\_ filed on in (country) \_\_\_\_\_ is claimed under 35 U.S.C. § 119.

a) \_\_\_ Certified copy is on file in prior application  
Serial No. \_\_\_\_\_ filed \_\_\_\_\_.

b) \_\_\_ Certified copy filed herewith.

X Amend the specification by inserting following before the first line thereof:

This is a **divisional** application of application Serial No. 10/382,577 filed March 7, 2003, which was a divisional application of Ser. No. 09/822,866 filed April 2, 2001, now Patent 6,554,088, which was a continuation-in-part of Ser. No 09/264,817 filed March 9, 1999, now U.S. patent 6,209,672, issued April 3, 2001, which in turn claimed priority from provisional application Ser. No. 60/100,095, filed September 14, 1998, and was also a continuation-in-part of Ser. No 09/392,743, filed September 9, 1999, now U. S. patent 6,338,391 issued January 15, 2002, in turn claiming priority from provisional application Ser. No. 60/122,296, filed March 1, 1999.

\_\_\_ Transfer the drawings for the prior application to this application, and abandon said prior application as of the

filing date accorded this application. A duplicate copy of this sheet is enclosed for filing in the prior application file.

X New formal drawings are enclosed.

X The prior application is assigned of record to PAICE LLC via a document dated April 28, 2004 and recorded by the U.S. Patent and Trademark Office on April 28, 2004 at Reel 014546 Frame 0351.

X The power of attorney in the prior application (filed in grandparent application Ser. No. 09/822,866) is to Michael de Angeli, Reg. No. 27,869. The power was filed June 26, 2001.

X Address all future communications to:

Michael de Angeli  
60 Intrepid Lane  
Jamestown RI 02835  
401-423-3190

X The undersigned declare further that all statements made herein of his own knowledge are true and that all statements made on information and belief are believed to be true; and further that these statements were made with the knowledge that willful false statements and the like so made are punishable by fine or imprisonment, or both, under Section 1001 of Title 18 of the United States Code and that such willful false statements may jeopardize the validity of the application or any patent issuing thereon.

Respectfully submitted,

Dated *May 5, 2006*

  
\_\_\_\_\_  
Michael de Angeli  
Reg. No. 27,869  
60 Intrepid Lane  
Jamestown RI 02835  
401-423-3190

## HYBRID VEHICLES

Inventors: Alex J. Severinsky  
Theodore N. Louckes

### Cross-Reference to Related Applications

5 This application is a continuation-in-part of Ser. No. 09/264,817, filed March 9, 1999, now U. S. patent 6,209,672, issued April 3, 2001, which in turn claims priority from provisional application Ser. No. 60/100,095, filed September 14, 1998, and is also a continuation-in-part of Ser. No. 09/392,743, filed September 9, 1999, which in turn claims priority from provisional application  
10 Ser. No. 60/122,296, filed March 1, 1999.

### Field of the Invention

15 This application relates to improvements in hybrid vehicles, that is, vehicles in which both an internal combustion engine and one or more electric motors are provided to supply torque to the driving wheels of the vehicle. More particularly, this invention relates to a hybrid electric vehicle that is fully competitive with presently conventional vehicles as regards performance, operating convenience, and cost, while achieving substantially improved fuel  
20 economy and reduced pollutant emissions.

### Discussion of the Prior Art

25 For many years great attention has been given to the problem of reduction of fuel consumption of automobiles and other highway vehicles. Concomitantly very substantial attention has been paid to reduction of pollutants emitted by automobiles and other vehicles. To a degree, efforts to solve these problems conflict with one another. For example, increased thermodynamic efficiency and thus reduced fuel consumption can be realized if an engine is  
30 operated at higher temperatures. Thus there has been substantial interest in engines built of ceramic materials withstanding higher

combustion temperatures than those now in use. However, higher combustion temperatures in gasoline-fueled engines lead to increase in certain undesirable pollutants, typically NO<sub>x</sub>.

Another possibility for reducing emissions is to burn mixtures of gasoline and ethanol ("gasohol"), or straight ethanol. However, to date ethanol has not become economically competitive with gasoline, and consumers have not accepted ethanol to any great degree. Moreover, to make an alternate fuel such as ethanol available to the extent necessary to achieve appreciable improvements in nationwide air quality and fuel conservation would require immense costs for infrastructure improvements; not only the entire nation's motor fuel production and delivery system, but also the vehicle manufacture, distribution, and repair system, would have to be extensively revised or substantially duplicated.

One proposal for reducing pollution in cities is to limit the use of vehicles powered by internal combustion engines and instead employ electric vehicles powered by rechargeable batteries. To date, all such "straight electric" cars have had very limited range, typically no more than 150 miles, have insufficient power for acceleration and hill climbing except when the batteries are substantially fully charged, and require substantial time for battery recharging. Thus, while there are many circumstances in which the limited range and extended recharging time of the batteries would not be an inconvenience, such cars are not suitable for all the travel requirements of most individuals. Accordingly, an electric car would have to be an additional vehicle for most users, posing a substantial economic deterrent. Moreover, it will be appreciated that in the United States most electricity is generated in coal-fired power plants, so that using electric vehicles merely moves the source of the pollution, but does not eliminate it. Furthermore, comparing the respective net costs per mile of driving, electric vehicles are not competitive with ethanol-fueled vehicles, much less with conventional gasoline-fueled vehicles. See, generally, Simanaitis, "Electric Vehicles",

Road & Track, May 1992, pp. 126-136; Reynolds, "AC Propulsion CRX", Road & Track, October 1992, pp. 126-129.

Brooks et al U.S. patent 5,492,192 shows such an electric vehicle; the invention appears to be directed to incorporation of antilock braking and traction control technologies into an otherwise conventional electric vehicle.

Much attention has also been paid over the years to development of electric vehicles including internal combustion engines powering generators, thus eliminating the defect of limited range exhibited by simple electric vehicles. The simplest such vehicles operate on the same general principle as diesel-electric locomotives used by most railroads. In such systems, an internal combustion engine drives a generator providing electric power to traction motors connected directly to the wheels of the vehicle. This system has the advantage that no variable gear ratio transmission is required between the engine and the wheels of the vehicle.

More particularly, an internal combustion engine produces zero torque at zero engine speed (RPM) and reaches its torque peak somewhere in the middle of its operating range. Accordingly, all vehicles driven directly by an internal combustion engine (other than certain single-speed vehicles using friction or centrifugal clutches, and not useful for normal driving) require a variable-ratio transmission between the engine and the wheels, so that the engine's torque can be matched to the road speeds and loads encountered. Further, some sort of clutch must be provided so that the engine can be mechanically decoupled from the wheels, allowing the vehicle to stop while the engine is still running, and to allow some slippage of the engine with respect to the drive train while starting from a stop. It would not be practical to provide a diesel locomotive, for example, with a multiple speed transmission, or a clutch. Accordingly, the additional complexity of the generator and electric traction motors is accepted. Electric traction motors produce full torque at zero RPM and thus can be

connected directly to the wheels; when it is desired that the train should accelerate, the diesel engine is simply throttled to increase the generator output and the train begins to move.

5 The same drive system may be employed in a smaller vehicle such as an automobile or truck, but has several distinct disadvantages in this application. In particular, and as discussed in detail below in connection with Figs. 1 and 2, it is well known that a gasoline or other internal combustion engine is most efficient when producing near its maximum output torque. 10 Typically, the number of diesel locomotives on a train is selected in accordance with the total tonnage to be moved and the grades to be overcome, so that all the locomotives can be operated at nearly full torque production. Moreover, such locomotives tend to be run at steady speeds for long periods of time. Reasonably efficient 15 fuel use is thus achieved. However, such a direct drive vehicle would not achieve good fuel efficiency in typical automotive use, involving many short trips, frequent stops in traffic, extended low-speed operation and the like.

20 So-called "series hybrid" electric vehicles have been proposed for automotive use, wherein batteries are used as energy storage devices, so that an internal combustion engine provided to power a generator can be operated in its most fuel-efficient output power range while still allowing the electric traction motor(s) powering the vehicle to be operated as required. Thus the engine may be 25 loaded by supplying torque to a generator charging the batteries while supplying electrical power to the traction motor(s) as required, so as to operate efficiently. This system overcomes the limitations of electric vehicles noted above with respect to limited range and long recharge times. Thus, as compared to a 30 conventional vehicle, wherein the internal combustion engine delivers torque directly to the wheels, in a series hybrid electric vehicle, torque is delivered from the engine to the wheels via a serially connected generator used as a battery charger, the battery, and the traction motor. However, energy transfer between

those components consumes at least approximately 25% of engine power. Further, such components add substantially to the cost and weight of the vehicle; in particular, an electric motor capable of providing sufficient torque to meet all expected demand, e.g., to allow reasonable performance under acceleration, during hill-climbing and the like, is rather heavy and expensive. Thus, series hybrid vehicles have not been immediately successful.

A more promising "parallel hybrid" approach is shown in U.S. Patent Nos. 3,566,717 and 3,732,751 to Berman et al. In Berman et al an internal combustion engine and an electric motor are matched through a complex gear train so that both can provide torque directly to the wheels, the vehicle being operated in several different modes. Where the output of the internal combustion engine is more than necessary to drive the vehicle ("first mode operation") the engine is run at constant speed and excess power is converted by a first motor/generator ("speeder") to electrical energy for storage in a battery. In "second mode operation", the internal combustion engine drives the wheels directly, and is throttled. When more power is needed than the engine can provide, a second motor/generator or "torquer" provides additional torque as needed.

Berman et al thus show two separate electric motor/generators separately powered by the internal combustion engine; the "speeder" charges the batteries, while the "torquer" propels the vehicle forward in traffic. This arrangement is a source of additional complexity, cost and difficulty, as two separate modes of engine control are required. Moreover, the operator must control the transition between the several modes of operation. Such a complex vehicle is unsuited for the automotive market. Automobiles intended for mass production can be no more complicated to operate than conventional vehicles, and must be essentially "foolproof", that is, resistant to damage that might be caused by operator error. Further, the gear train shown by Berman et al appears to be quite complex and difficult to manufacture economically. Berman et



al also indicate that one or even two variable-speed transmissions may be required; see, e.g., col. 3, lines 19 - 22 and 36 - 38 of patent 3,566,717, and col. 2, lines 53 - 55 of patent 3,732,751.

Lynch et al patent 4,165,795 also shows an early parallel hybrid drive. Lynch argues that maximum fuel efficiency can be realized when a relatively small internal combustion engine is provided, such that when the engine is operated at an efficient speed, it produces approximately the average power required over a typical mission. The example given is of an engine producing 25 hp maximum and 17 hp at its most efficient speed, about 2500 rpm. This is to be combined with an electric motor-generator of about 30 peak hp. This vehicle requires a variable-ratio transmission to achieve reasonable performance. It appears that the engine is to be run continuously, at a steady speed, with additional torque provided by the motor when needed and excess torque produced by the engine being used to charge the batteries. In a first embodiment, torque provided by the motor is transmitted to the drive wheels through the engine, while in a second embodiment their respective positions are reversed.

Nishida U.S. patent 5,117,931 shows a parallel hybrid vehicle where torque from an electric motor may be combined with torque from an internal combustion engine in a "torque transmission unit" comprising paired bevel gears and means for controlling the relative rates of rotation of the motor and engine, so that the motor can be used to start the engine, absorb excess torque from the engine (by charging a battery), or provide additional propulsive torque. A variable-speed transmission is coupled between the torque transmission unit and the propelling wheels. Both the torque transmission unit and the variable-speed transmission are complex, heavy, and expensive components, the use of which would preferably be avoided.

Helling U.S. patent 3,923,115 also shows a hybrid vehicle having a torque transmission unit for combining torque from an electric motor and an internal combustion engine. However, in

Helling the relative rates of rotation of the motor and engine input shafts are fixed; a flywheel is provided to store excess mechanical energy as well as a battery to store excess electrical energy. Albright, Jr. et al patent 4,588,040 shows another hybrid drive scheme using a flywheel in addition to batteries to store excess energy; various complicated mechanical connections are provided between the various components. Capacitors have also been proposed for energy storage; see Bates et al U.S. patent 5,318,142.

Fjällström U.S. patent 5,120,282 shows a parallel hybrid drive train wherein torque from two electric motors is combined with torque produced by an internal combustion engine; the combination is performed by a complex arrangement of paired planetary gearsets, and unspecified control means are alleged to be able to allow variation of road speed without a variable-ratio transmission.

Hunt U.S. Patent Nos. 4,405,029 and 4,470,476 also disclose parallel hybrids requiring complex gearing arrangements, including multiple speed transmissions. More specifically, the Hunt patents disclose several embodiments of parallel hybrid vehicles. Hunt indicates (see col. 4, lines 6 - 20 of the '476 patent) that an electric motor may drive the vehicle at low speeds up to 20 mph, and an internal combustion engine used for speeds above 20 mph, while "in certain speed ranges, such as from 15 - 30 mph, both power sources may be energized... Additionally, both power sources could be utilized under heavy load conditions." Hunt also indicates that "the vehicle could be provided with an automatic changeover device which automatically shifts from the electrical power source to the internal combustion power source, depending on the speed of the vehicle" (col. 4, lines 12 - 16).

However, the Hunt vehicle does not meet the objects of the present invention, as discussed in detail below. Hunt's vehicle in each embodiment requires a conventional manual or automatic transmission. See col. 2, lines 6 - 7. Moreover, the internal combustion engine is connected to the transfer case (wherein torque from the internal combustion engine and electric motor is combined)

by a "fluid coupling or torque converter of conventional construction". Col. 2, lines 16 - 17. Such transmissions and fluid couplings or torque converters are very inefficient, are heavy, bulky, and costly, and are to be eliminated according to one object of the present invention, again as discussed in detail below.

Furthermore, the primary means of battery charging disclosed by Hunt involves a further undesirable complexity, namely a turbine driving the electric motor in generator configuration. The turbine is fueled by waste heat from the internal combustion engine. See col. 3, lines 10 - 60. Hunt's internal combustion engine is also fitted with an alternator, for additional battery charging capability, adding yet further complexity. Thus it is clear that Hunt fails to teach a hybrid vehicle meeting the objects of the present invention - that is, a hybrid vehicle competitive with conventional vehicles with respect to performance, cost and complexity, while achieving substantially improved fuel efficiency.

Kawakatsu U.S. Patents Nos. 4,305,254 and 4,407,132 show a parallel hybrid involving a single internal combustion engine coupled to the drive wheels through a conventional variable-ratio transmission, an electric motor, and an alternator, to allow efficient use of the internal combustion engine. As in the Hunt disclosure, the engine is intended to be operated in a relatively efficient range of engine speeds; when it produces more torque than is needed to propel the vehicle, the excess is used to charge the batteries; where the engine provides insufficient torque, the motor is energized as well.

A further Kawakatsu patent, No. 4,335,429, shows a hybrid vehicle, in this case comprising an internal combustion engine and two motor/generator units. A first larger motor/generator, powered by a battery, is used to provide additional torque when that provided by the engine is insufficient; the larger motor-generator also converts excess torque provided by the engine into electrical energy, to be stored by the battery, and is used in a regenerative braking mode. The second smaller motor/generator is similarly used

to provide additional torque and additional regenerative braking as needed.

More particularly, the latter Kawakatsu patent asserts that a single electric motor sized to provide sufficient torque to propel the vehicle would not be capable of providing sufficient regenerative braking force; see col. 1, line 50 - col. 2 line 8. Accordingly, Kawakatsu provides two separate motor/generators, as noted; a separate engine starting motor is also provided. See col. 6, lines 22 - 23. In the embodiment shown, the larger motor/generator is connected to the wheel drive shaft, while the engine and the smaller motor/generator are connected to the wheels through a complex mechanism comprising three separately-controllable clutches. See col. 5, lines 50 - 62.

Numerous patents disclose hybrid vehicle drives tending to fall into one or more of the categories discussed above. A number of patents disclose systems wherein an operator is required to select between electric and internal combustion operation; for example, an electric motor is provided for operation inside buildings where exhaust fumes would be dangerous, and an internal combustion engine provided for operation outdoors. It is also known to propose a hybrid vehicle comprising an electric motor for use at low speeds, and an internal combustion engine for use at higher speed. The art also suggests using both when maximum torque is required. In several cases the electric motor drives one set of wheels and the internal combustion engine drives a different set. See generally Shea (4,180,138); Fields et al (4,351,405); Kenyon (4,438,342); Krohling (4,593,779); and Ellers (4,923,025).

Many of these patents show hybrid vehicle drives wherein a variable speed transmission is required, as do numerous additional references. A transmission as noted above is typically required where the internal combustion engine and/or the electric motor are not capable of supplying sufficient torque at low speeds. See Rosen (3,791,473); Rosen (4,269,280); Fiala (4,400,997); and Wu et al (4,697,660). Kinoshita (3,970,163) shows a vehicle of this general

type wherein a gas turbine engine is coupled to the road wheels through a three-speed transmission; an electric motor is provided to supply additional torque at low speeds.

5 For further examples of series hybrid vehicles generally as discussed above, see Bray (4,095,664); Cummings (4,148,192); Monaco et al (4,306,156); Park (4,313,080); McCarthy (4,354,144); Heidemeyer (4,533,011); Kawamura (4,951,769); and Suzuki et al (5,053,632). Various of these address specific problems arising in the manufacture or use of hybrid vehicles, or specific alleged design improvements. For example, Park addresses certain specifics of battery charging and discharge characteristics, while McCarthy shows a complex drive system involving an internal combustion engine driving two electric motors; the torque generated by the latter is combined in a complex differential providing continuously variable gear ratios. Heidemeyer shows connecting an internal combustion engine to an electric motor by a first friction clutch, and connecting the motor to a transmission by a second friction clutch.

10  
15  
20  
25  
30  
Other patents of general relevance to this subject matter include Toy (3,525,874), showing a series hybrid using a gas turbine as internal combustion engine; Yardney (3,650,345), showing use of a compressed-air or similar mechanical starter for the internal combustion engine of a series hybrid, such that batteries of limited current capacity could be used; and Nakamura (3,837,419), addressing improvements in thyristor battery-charging and motor drive circuitry. Somewhat further afield but of general interest are the disclosures of Deane (3,874,472); Horwinski (4,042,056); Yang (4,562,894); Keedy (4,611,466); and Lexen (4,815,334); Mori (3,623,568); Grady, Jr. (3,454,122); Papst (3,211,249); Nims et al (2,666,492); and Matsukata (3,502,165). Additional references showing parallel hybrid vehicle drive systems include Froelich (1,824,014) and Reinbeck (3,888,325). U.S. Patent No. 4,578,955 to Medina shows a hybrid system wherein a gas turbine is used to drive a generator as needed to charge batteries. Of

particular interest to certain aspects of the present invention is that Medina discloses that the battery pack should have a voltage in the range of 144, 168 or 216 volts and the generator should deliver current in the range of 400 to 500 amperes. Those of skill in the art will recognize that these high currents involve substantial resistance heating losses, and additionally require that all electrical connections be made by positive mechanical means such as bolts and nuts, or by welding. More specifically, for reasons of safety and in accordance with industry practice, currents in excess of about 50 amperes cannot be carried by the conventional plug-in connectors preferred for reasons of convenience and economy, but must be carried by much heavier, more expensive and less convenient fixed connectors (as used on conventional starter and battery cable connections). Accordingly, it would be desirable to operate the electric motor of a hybrid vehicle at lower currents.

U.S. patent 5,765,656 to Weaver also shows a series hybrid wherein a gas turbine is used as the internal combustion engine; hydrogen is the preferred fuel.

U.S. Patent No. 4,439,989 to Yamakawa shows a system wherein two different internal combustion engines are provided, so that only one need be run when the load is low. This arrangement would be complex and expensive to manufacture.

Detailed discussion of various aspects of hybrid vehicle drives may be found in Kalberlah, "Electric Hybrid Drive Systems for Passenger Cars and Taxis", SAE Paper No. 910247 (1991). Kalberlah first compares "straight" electric, series hybrid, and parallel hybrid drive trains, and concludes that parallel hybrids are preferable, at least when intended for general use (that is, straight electric vehicles may be useful under certain narrow conditions of low-speed, limited range urban driving). Kalberlah then compares various forms of parallel hybrids, with respect to his Fig. 4, and concludes that the most practical arrangement is one in which an internal combustion engine drives a first pair of

wheels, and an electric motor the second; more particularly, Kalberlah indicates that mechanical combination of the torque from an internal combustion engine and an electric motor is impractical.

Gardner U.S. patents 5,301,764 and 5,346,031 follow Kalberlah's teachings, in that Gardner shows separately driving at least two pairs of wheels; one pair is driven by a first electric motor, and the second by a second electric motor or alternatively by a small internal combustion engine. Three different clutches are provided to allow various sources of drive torque to be connected to the wheels, and to a generator, depending on the vehicle's operation mode. The internal combustion engine is run continuously, and provides the driving torque when the vehicle is in a cruise mode; at other times it is used to charge the batteries powering the electric motors.

Bullock, "The Technological Constraints of Mass, Volume, Dynamic Power Range and Energy Capacity on the Viability of Hybrid and Electric Vehicles", SAE Paper No. 891659 (1989) provides a detailed theoretical analysis of electric vehicles in terms of the loads thereon, and a careful analysis of the various battery types then available. Bullock concludes that a vehicle having two electric motors of differing characteristics, driving the wheels through a variable-speed transmission, would be optimal for automotive use; see the discussion of Fig. 8. Bullock also suggests the use of an internal combustion engine to drive battery charging, but does not address combining the engine's torque with that from the motors; see pp. 24 - 25.

Further related papers are collected in Electric and Hybrid Vehicle Technology, volume SP-915, published by SAE in February 1992. See also Wouk, "Hybrids: Then and Now"; Bates, "On the road with a Ford HEV", and King et al, "Transit Bus takes the Hybrid Route", all in IEEE Spectrum, Vol. 32, 7, (July 1995).

Urban et al U.S. patent 5,667,029 shows two embodiments of parallel hybrids; a first embodiment is shown in Figs. 1 - 9 and 11, and a second in Figs. 12 - 17. Both embodiments have numerous

common features, including similar operating modes. Referring to the first embodiment, an internal combustion engine provides torque to the road wheels or to a generator; two electric motors can provide torque to the road wheels, or charge batteries during regenerative braking. Torque from the engine and motors is combined at the input shaft to a variable-ratio transmission. Overrunning clutches are provided, e.g., to allow the engine's torque to be applied to the road wheels without also rotating the motors.

As indicated at col. 6, lines 25 - 54, certain transitions between various operating modes are made automatically, responsive to the position of the accelerator pedal; for example, if the operator does not depress the pedal beyond a given point, only the internal combustion engine is employed to propel the vehicle; if the operator depresses the pedal more fully, the electric motors are also energized. Other changes in the operational mode must be made by the operator directly; for example, the vehicle may be operated as a "straight electric" vehicle, e.g. for short duration trips, by the operator's making an appropriate control action. See col. 7, lines 49 - 56.

The Urban et al design appears to suffer from a number of significant defects. First, the internal combustion engine is stated to provide all torque needed to accelerate the vehicle to cruising speed under normal circumstances (see col. 5, lines 3 - 10), and also to propel the vehicle during cruising (see col. 6, lines 48 - 54). The electric motors are to be used only during rapid acceleration and hill-climbing; col. 5, lines 10 - 13. A 20 horsepower engine, operated through a continuously variable-ratio transmission and a torque converter, is stated to be adequate for this purpose. Such components are clearly complex and expensive; further, torque converters are notoriously inefficient. Moreover, using the internal combustion engine as the sole source of power for low-speed running would require it to be run at low speeds, e.g., at traffic lights, which is very inefficient and highly



polluting. (Various additional references suggest that excess torque can be used to charge batteries; if this were incorporated in the Urban system, the engine might be run at a reasonably efficient output level while the vehicle was stationary, but this would lead to high levels of noise and vibration. In any event Urban does not appear to consider this possibility.)

On the other hand, Urban does suggest that the vehicle can be operated as a "straight electric" under low-speed conditions, but this requires the operator to provide an explicit control input; this complexity is unacceptable in a vehicle intended to be sold in quantity, as would be required in order to reach Urban's stated goals of reduction of atmospheric pollution and reduced energy consumption. As noted, hybrid vehicle operation must be essentially "foolproof", or "transparent" to the user, to have any chance of commercial success.

Urban's second embodiment is mechanically simpler, employing but a single "dynamotor", through which torque is transmitted from the engine to the variable-ratio transmission, but suffers from the same operational deficiencies.

A second Urban et al patent, 5,704,440, is directed to the method of operation of the vehicle of the '029 patent and suffers the same inadequacies.

Various articles describe several generations of Toyota Motor Company hybrid vehicles, believed to correspond to that available commercially as the "Prius". See, for example, Yamaguchi, "Toyota readies gasoline/electric hybrid system", Automotive Engineering, July 1997, pp. 55 - 58; Wilson, "Not Electric, Not Gasoline, But Both", Autoweek, June 2, 1997, pp. 17 - 18; Bulgin, "The Future Works, Quietly", Autoweek February 23, 1998, pp. 12 and 13; and "Toyota Electric and Hybrid Vehicles", a Toyota brochure. A more detailed discussion of the Toyota vehicle's powertrain is found in Nagasaka et al, "Development of the Hybrid/Battery ECU for the Toyota Hybrid System", SAE paper 981122 (1998), pp. 19 - 27. According to the Wilson article, Toyota describes this vehicle as

a "series-parallel hybrid"; regardless of the label applied, its powertrain appears to be similar to that of the Berman patents described above, that is, torque from either or both of an internal combustion engine and an electric motor are controllably combined in a "power-split mechanism" and transmitted to the drive wheels through a planetary gearset providing the functionality of a variable-ratio transmission. See the Nagasaka article at pp. 19 - 20.

Furutani U.S. patent 5,495,906 describes a vehicle having an internal combustion engine driving a first set of wheels through a variable-ratio transmission and an electric motor driving a second set of wheels. The engine is apparently intended to be run continuously; at low speeds, it drives a generator to charge batteries providing energy to the motor, and at higher speeds the engine or both engine and motor propel the vehicle. In some circumstances the transmission may not be required; compare, for example, col. 3, lines 4 - 8 with col. 5, lines 59 - 64.

U.S. patent 5,842,534 to Frank shows a "charge depletion" control method for hybrid vehicles; in this scheme, the internal combustion engine is essentially used only when the state of the batteries is such that the vehicle cannot otherwise reach a recharging point. See col. 3, lines 50 - 55. In normal operation, the batteries are recharged from an external power source. Frank also discusses two-mode brake pedal operation, wherein mechanical brakes are engaged in addition to regenerative braking when the pedal is depressed beyond a preset point.

U.S. patent 5,823,280 to Lateur et al shows a parallel hybrid wherein the shafts of an internal combustion engine and first and second electric motors are all coaxial; the engine is connected to the first motor by a clutch, and the first motor to the second by a planetary gearset, allowing the speeds of the motors to be varied so as to operate them in their most efficient range. See col. 4, line 57 - col. 5, line 60.

U.S. patent 5,826,671 to Nakae et al shows a parallel hybrid

wherein torque from an internal combustion engine is combined with that from a motor in a planetary gearset; a clutch is provided therebetween. The specific invention relates to sensing of engine warmup conditions, so as to limit emission of unburnt fuel and thus lower emissions.

U.S. patent 5,846,155 to Taniguchi et al shows a parallel hybrid wherein torque from an internal combustion engine and a motor is again combined in a planetary gearset; the specific improvement appears to be the use of a continuously-variable transmission.

It will be appreciated by those of skill in the art that there are significant limitations inherent in the use of planetary gearsets as a means for connecting different sources, e.g., an internal combustion engine and an electric motor, to the drive wheels of a vehicle, namely, that unless the planetary gearset is effectively locked (anathematic to its use as a continuously-variable transmission, e.g., in the Toyota vehicle) it is capable of additive combination of shaft speeds, but not of output torque. Hence, the principal advantage of the parallel hybrid drivetrain, additive combination of the output torque of both the electric motor and the internal combustion engine, is only available when the planetary gearset is locked. This fact is acknowledged by Lateur, for example, at col. 6, line 27.

Additional disclosures of possible interest include U.S. patent 5,845,731 to Buglione et al; this patent issued December 8, 1998, and therefore is not necessarily available as a reference against the claims of the present application. The basic powertrain shown by Buglione et al includes an internal combustion engine 12, coupled through a first clutch 18 to a first electric motor 20, coupled to a second electric motor 26 through a second clutch 24; the wheels are (apparently; see col. 3, line 8) driven by the second motor 26. The overall hybrid operational scheme provided by Buglione et al is illustrated in Fig. 4. At low speeds one or both motors may be used to propel the vehicle, with the engine off,

idling, or running to drive one motor as a generator. During low-speed cruising the second motor propels the vehicle, while during high-speed cruising, the engine propels the vehicle. When acceleration is required at high speed, the engine and both motors may be used to propel the vehicle. Buglione et al also indicates that a variable-ratio transmission may be unnecessary, col. 3, line 9, and that the first motor can be used to start the engine, col. 4, lines 8 - 15.

U.S. patent 5,586,613 to Ehsani, showing an "electrically peaking hybrid" vehicle is also of interest. Ehsani's vehicle is shown in several embodiments; in each, an engine is apparently to be run continuously, with excess torque used to charge the batteries, and one or more motors used to provide additional propulsive torque when the engine's output torque is inadequate. A transmission is provided in some embodiments of the Ehsani vehicle. An embodiment involving two motors is shown in Fig. 7, and can be modified as discussed in the text at col. 9, lines 4 - 5. Fig. 7 itself shows driving a first set of wheels by a first "electric machine", i.e., a motor capable of operation as a generator. This drive arrangement is independent of a second drive arrangement, whereby a second set of wheels is driven by an engine connected through a first clutch to a second electric machine, connected to the second set of wheels by a second clutch. Ehsani suggests at col. 9, lines 4 - 5 that the drive shaft otherwise coupled to the first electric machine could also be driven by the engine. Although it is not made explicit that the first electric machine is to be retained, this seems likely; otherwise, the modified Fig. 7 embodiment would be the same as Ehsani's Fig. 1, modified to have all four wheels driven by a common driveshaft.

This application discloses a number of improvements over and enhancements to the hybrid vehicles disclosed in U.S. patent 5,343,970 (the "'970 patent"), to one of the present inventors, which is incorporated herein by this reference. Where differences are not mentioned, it is to be understood that the specifics of the

vehicle design shown in the '970 patent are applicable to the vehicles shown herein as well. Discussion of the '970 patent herein is not to be construed to limit the scope of its claims.

5 Generally speaking, the '970 patent discloses hybrid vehicles wherein a controllable torque transfer unit is provided capable of transferring torque between an internal combustion engine, an electric motor, and the drive wheels of the vehicle. The direction of torque transfer is controlled by a microprocessor responsive to the mode of operation of the vehicle, to provide highly efficient operation over a wide variety of operating conditions, and while providing good performance. The flow of energy - either electrical energy stored in a substantial battery bank, or chemical energy stored as combustible fuel - is similarly controlled by the microprocessor.

15 For example, according to the operating scheme of the hybrid vehicle disclosed in the '970 patent, in low-speed city driving, the electric motor provides all torque needed responsive to energy flowing from the battery. In high-speed highway driving, where the internal-combustion engine can be operated efficiently, it typically provides all torque; additional torque may be provided by the electric motor as needed for acceleration, hill-climbing, or passing. The electric motor is also used to start the internal-combustion engine, and can be operated as a generator by appropriate connection of its windings by a solid-state, microprocessor-controlled inverter. For example, when the state of charge of the battery bank is relatively depleted, e.g., after a lengthy period of battery-only operation in city traffic, the internal combustion engine is started and drives the motor at between 50 and 100% of its maximum torque output, for efficient charging of the battery bank. Similarly, during braking or hill descent, the kinetic energy of the vehicle can be turned into stored electrical energy by regenerative braking.

30 The hybrid drive train shown in the '970 patent has many advantages with respect to the prior art which are retained by the

present invention. For example, the electric drive motor is selected to be of relatively high power, specifically, equal to or greater than that of the internal combustion engine, and to have high torque output characteristics at low speeds; this allows the conventional multi-speed vehicle transmission to be eliminated. As compared to the prior art, the battery bank, motor/generator, and associated power circuitry are operated at relatively high voltage and relatively low current, reducing losses due to resistive heating and simplifying component selection and connection.

It can thus be seen that while the prior art, including the '970 patent, clearly discloses the desirability of operating an internal combustion engine in its most efficient operating range, and that a battery may be provided to store energy to be supplied to an electric motor in order to even out the load on the internal combustion engine, there remains substantial room for improvement. In particular, it is desired to obtain the operational flexibility of a parallel hybrid system, while optimizing the system's operational parameters and providing a substantially simplified parallel hybrid system as compared to those shown in the prior art, again as including the '970 patent.

As noted above, the present application is a continuation-in-part of Ser. No. 09/264,817, filed March 9, 1999 (the '817 application), which discloses and claims several distinct improvements over the hybrid vehicles shown in the '970 patent, as discussed in further detail below. Similarly, the present application is a continuation-in-part of Ser. No. 09/392,743, filed September 9, 1999 (the '743 application), which discloses and claims several distinct improvements over the hybrid vehicles shown in the '970 patent and the '817 application, as discussed in further detail below. The present application discloses and claims further improvements over the vehicles of the '817 and '743 applications.

As discussed in detail below, the '817 and '743 applications (which are not to be limited by this brief summary) disclose a new

"topology" for a hybrid vehicle, wherein an internal combustion engine and a first electric "starting" motor, which can be operated as a starter, to start the engine, a generator, to charge the battery bank responsive to torque from the engine or the wheels (i.e., during regenerative braking) or as a source of torque, to propel the vehicle, are connected to the road wheels of the vehicle through a clutch, so that the engine can be decoupled from the wheels during starting and battery charging, but can be connected to the wheels to propel the vehicle. A second "traction" motor is directly connected to the road wheels to propel the vehicle. The vehicle operating mode is determined by a microprocessor responsive to the "road load", that is, the vehicle's instantaneous torque demands. The '743 application further discloses that a turbocharger may be provided, and operated when needed to increase the torque output of the engine when torque in excess of its normally-aspirated capacity is required for more than a minimum time. The present application builds further on these concepts.

Koide U.S. patent 5,934,395 and Schmidt-Brücken U.S. patent 6,059,059 were addressed during the prosecution of the '817 application. Tsuzuki 6,018,198 and Werson 5,986,376 were also each applied against one claim. As indicated, the '817 application discloses a hybrid vehicle comprising a controller, a battery bank, an internal combustion engine, and two electric motors, a starting motor and a traction motor. The starting motor and engine are connected to the road wheels through a clutch, while the traction motor is connected directly and permanently to the road wheels for torque transmission therebetween, i.e., without a clutch therebetween. Koide does not show this "topology" for a hybrid vehicle; although Koide does show a hybrid vehicle having first and second motors along with an engine, the components are not connected as described. Specifically, in Koide, both motors and the engine are connected to the road wheels by way of a variable-ratio transmission and a clutch, while, as noted, in the '817 application only the combination of the engine and starting motor

is connected to the wheels through a clutch, while the traction motor is connected directly to the wheels for torque transmission therebetween, that is, without a clutch or variable-ratio transmission. More specifically, Koide's entire disclosure is premised on being able to vary the ratios between the torque-producing components of his system and the road wheels, in order that the engine can be smoothly started when needed. According to the '817 application, only the starter motor and engine need to be disconnectible from the wheels for smooth starting, while the traction motor can be connected to the road wheels at all times. This represents a substantial simplification with respect to the system shown by Koide.

The Schmidt-Brücken patent also fails to show the topology shown in the '817 application. Schmidt-Brücken shows an engine 1 in combination with a starting motor 7, connected to the road wheels through a first clutch 11, and a traction motor 19 connected to the road wheels through a second clutch 23.

The '817 and '743 applications also disclose that the vehicle operating mode is determined by a microprocessor responsive to the "road load", that is, the vehicle's instantaneous torque demands, i.e., that amount of torque required to propel the vehicle at a desired speed. The operator's input, by way of the accelerator or brake pedals, or a "cruise control" device, indicates that continuing at steady speed is desired, or that a change in vehicle speed is called for. For example, the operator's depressing the accelerator pedal signifies an increase in desired speed, i.e., an increase in road load, while reducing the pressure on the accelerator or depressing the brake pedal signifies a desired reduction in vehicle speed, indicating that the torque being supplied is to be reduced or should be negative. More particularly, it is important to note that the road load can vary between wide limits, independent of vehicle speed, and can be positive or negative, i.e., when decelerating or descending a hill, in which case the negative road load (that is, torque available at



the wheels in excess of that required to propel the vehicle) is usually employed to charge the battery bank.

5 More particularly, it is important to recognize that road load is not the same thing as vehicle velocity. Indeed, as noted, road load can be negative while vehicle velocity is positive, as during deceleration or descent. Moreover, widely differing road loads may be encountered during operation at the same velocity; for example, operation at 50 mph on a flat road may involve a road load of only 30 - 40% of the engine's maximum output torque (MTO), while  
10 accelerating from the same speed while climbing a hill may involve a road load of well over 100% of MTO.

By the same token, control of the vehicle's operating mode in response to monitoring of road load is not the same as controlling its operating mode in response to vehicle speed. Numerous prior art  
15 references, including the Koide and Schmidt-Brücken patents, teach the latter, i.e., indicate the vehicle operating mode should be controlled in response to vehicle speed. See Koide at col. 12, lines 45 - 48, and Schmidt-Brücken at col. 5, line 56 - col. 6 line 29. Neither Koide nor Schmidt-Brücken, nor any other reference of  
20 which the inventors are aware, recognizes that the desired vehicle operational mode should preferably be controlled in response to the vehicle's actual torque requirements, i.e., the road load. Doing so according to the invention provides superior performance, in terms of both vehicle response to operator commands and fuel efficiency,  
25 under the widely-varying conditions encountered in "real world" driving situations, than is possible according to the prior art.

Moreover, as set forth in the '817 and '743 applications, in order to provide maximum efficiency in use of fuel, it is essential to operate the internal combustion engine of a hybrid vehicle only  
30 under circumstances where the engine will be loaded so as to require at least 30% of its maximum torque output ("MTO") (it being understood throughout this specification and the appended claims that this 30% figure is arbitrary and can be varied). If the vehicle is controlled to shift into an engine-only mode whenever it

exceeds some arbitrary road speed, as in Koide and Schmidt-Brücken, it is apparent that the engine will be operated at various times when the road load is less than 30% of MTO, for example, during deceleration or during descents. Moreover, as noted above, the torque actually required can vary widely irrespective of vehicle speed. For example, 30% of MTO may be sufficient to maintain steady speed on a flat road, but 150% of MTO may be required for acceleration from the same speed. If the vehicle's operational mode is selected based solely on speed, as taught by Koide and Schmidt-Brücken, it will be incapable of responding to the operator's commands, and will ultimately be unsatisfactory.

By comparison, according to the invention of the '817 and '743 applications, and as further disclosed and claimed herein, the vehicle's operating mode -- that is, the selection of the source of torque needed to propel the vehicle -- is determined based on the amount of torque actually required. In this way the proper combination of engine, traction motor, and starting motor is always available. This apparently-simple point has evidently been missed entirely by the art.

Moreover, according to this aspect of the invention, the engine is used to propel the vehicle only when it is efficient to do so. This is in accordance with another aspect of the invention, wherein the engine is operated only at high efficiency, leading directly to improved fuel economy. For example, the engine is also used as needed to charge the battery bank, e.g., in low-speed city driving, where the battery bank may become depleted. The starter motor, which is operated as a generator in these circumstances, is accordingly sized so as to be able to accept at least 30% of MTO as input torque; the battery bank is likewise sized so as to be able to accept a corresponding amount of charging current. Therefore the engine is never operated at less than 30% of MTO, and is thus never operated inefficiently. Koide and Schmidt-Brücken, because they teach switching the vehicle's operational mode based on vehicle speed and not its torque requirements, would inherently

operate the engine under less efficient conditions.

5 Furutani patent 5,495,906 discloses selection of operating mode based on a combination of vehicle speed and "vehicle load"; see, e.g., col. 2, lines 39 - 47: "It is preferable that the running state detection means detects vehicle speed and vehicle load...[and] that the control means transfers the driving force generated by the engine to the power generator and changes the electric power generated by the power generator [i.e., more of the engine power is used to charge the batteries] in accordance with the vehicle load if the vehicle speed is the predetermined value or less. Moreover, it is preferable to change the predetermined value of the vehicle speed in accordance with the vehicle load." It thus appears that Furutani determines the vehicle operating state based on vehicle speed, although the change-over speed can be varied responsive to the vehicle load. Furutani's "vehicle load" thus apparently includes the torque required to charge the battery, as distinguished from applicants' "road load", i.e., the torque required to propel the vehicle. Even assuming that Furutani's "vehicle load", which is not defined, were suggestive of "road load" as used by applicants, Furutani clearly does not suggest determining the operating mode based on road load. More specifically, although Furutani recognizes a distinction between differing vehicle loads, and that the vehicle load can vary independent of vehicle speed, the vehicle operating mode is nonetheless selected based on vehicle speed; see col. 3, line 62 - col. 4, line 32. Instead of varying the operating mode of the vehicle based on road load, Furutani directs more or less of the engine's torque to battery charging; see col. 4, lines 24 - 32.

15  
20  
25  
30 Frank 6,054,844 shows several embodiments of hybrid vehicles. In those where an engine is used to provide torque to the vehicle wheels, a continuously-variable transmission is employed, and the ratio R is considered in determining the response to be made to operator input, e.g., accelerator and brake pedal positions. Frank's control strategy is to operate the engine along a line of

optimal efficiency and use an electric motor to add to or subtract from the engine's output torque as appropriate. See col. 6, line 49 - col. 7, line 7 and col. 10, line 33 - col. 11, line 22. Frank thus does not suggest control of the vehicle operating mode responsive to road load.

Patent 6,018,694 to Egami et al shows a controller for a hybrid vehicle comprising an internal combustion engine and first and second "rotary electric units". Although the question is not free from doubt, it appears from a detailed review of Egami's disclosure that torque from the engine is not supplied directly to the road wheels, but instead is used to drive one of the rotary electric units as a generator, in turn supplying the second with current to provide torque for propelling the vehicle. Hence Egami does not show selection of the operational mode of the vehicle (that is, the determination whether propulsive torque is to be provided from the engine, one or both of the motors, or all three) in response to the road load, since it does not appear that propulsive torque is ever supplied from the engine to the wheels. Moreover, despite making reference to a "vehicle driving torque demand  $Mv^*$ ", which might be misunderstood to be equivalent to applicant's road load, Egami in fact does not determine the road load. More specifically,  $Mv^*$  is determined by consulting a "map", using "the vehicle speed  $V$ , the accelerator lift  $ACC$ , the brake state  $BRK$ , and the shift position  $SFT$  as the input parameters". See col. 22, lines 23 - 26. The same point, i.e., that the "vehicle driving torque demand  $Mv^*$ " is not equivalent to applicant's claimed road load, is made throughout Egami's extensive specification; see, for example, col. 10, lines 28 - 32 and col. 27, lines 58 - 65.

Deguchi patent 5,993,351 refers to decision-making regarding the vehicle mode of operation "based on the vehicle speed detected value and the required motive force detected value" (Abstract; see also col. 1, line 41); the latter might be misunderstood to be equivalent to the road load. Deguchi also states (col. 2, lines 7

- 9) that the vehicle "runs on the motor at times of low load and runs on the internal combustion engine at times of high load". However, Deguchi makes it clear that in fact the operational-mode decision is made "based on the accelerator aperture detected value  $\theta$  which represents the required driving force of the vehicle and the detected vehicle speed" (col. 5, lines 19 - 21). The accelerator position and vehicle speed signals are the only relevant inputs to the vehicle controller shown in Fig. 2. Hence Deguchi does not show controlling the vehicle operating mode responsive to road load as defined by applicants.

Along generally similar lines, Boll patent 5,327,992 teaches a hybrid vehicle comprising a diesel engine and a motor on a common shaft, and intended to be operated such that the engine is only operated efficiently, i.e., under relatively high load. The torque required to overcome the "instantaneous tractive resistance" is determined responsive to the deflection of the accelerator pedal, i.e., in response to operator command (see col. 3, line 13 and line 35); when this is less than the minimum amount of torque that can be produced efficiently by the engine, the excess torque is used to power the motor as a generator. Boll also suggests that both the motor and engine can be used to propel the vehicle when needed, e.g., during acceleration, and that the vehicle can be operated in four different modes: (a) engine alone powering the vehicle; (b) motor only powering the vehicle, with the engine "generally switched off"; (c) engine and motor both powering the vehicle; and (d) engine powering vehicle, with excess torque powering motor in generator mode. Boll also teaches that a second motor can be provided, operable as a generator and then driven either by the engine directly or by exhaust gas, and that the resulting current can be used to charge the battery or to power the other motor.

Other references of interest are directed to the braking systems of hybrid vehicles, see for example German patent 19 05 641 to Strifler, discussing a method of control of a braking system providing both regenerative and mechanical braking, and the

powering of ancillary systems, such as power steering pumps, see U.S. patent 5,249,637 to Heidl. These references are discussed in further detail below with reference to improvements provided in these areas by the present application.

5

### Objects of the Invention

10 It is an object of the invention to provide an improved hybrid electric vehicle realizing substantially increased fuel economy and reduced pollutant emissions as compared to present day internal combustion and hybrid vehicles while suffering no significant penalty in performance, operating convenience, cost, complexity, or weight, which can be operated efficiently by an operator accustomed to conventional vehicles without special training, and which does not require modification of the existing infrastructure developed over the years to support conventional vehicles.

15 More specifically, it is an object of the invention to provide such an improved vehicle that operates on fuel now widely available and uses batteries already well understood and widely available, so that the operator need not learn new driving techniques, deal with new fuel supply arrangements, nor be obliged to be attentive to maintenance of batteries employing complex new technologies.

20 It is a more particular object of the present invention to provide an improved series-parallel hybrid electric vehicle wherein an internal combustion engine and two separately-controlled electric motors can separately or simultaneously apply torque to the driving wheels of the vehicle, controlled to realize maximum fuel efficiency at no penalty in convenience, performance, or cost.

25 It is a further object of the invention to provide a series-parallel hybrid electric vehicle comprising two electric motors together providing output power equal to at least 100 percent of the rated output power of the internal combustion engine, and more preferably up to about 150 - 200 percent thereof, so that the engine operates under substantially optimum conditions in order to realize substantial fuel economy and reduced emission of

undesirable pollutants in operation.

More particularly, it is an object of the invention to provide a series-parallel hybrid electric vehicle wherein the internal combustion engine is sized to efficiently provide the average power required for operation at moderate and highway speeds, with two ) or more) separately-controlled electric motors together sized to deliver the additional power needed for acceleration and hill climbing.

Still another object of the invention is to provide a series-parallel hybrid electric vehicle wherein the electric motor and battery charging circuits operate at no more than about 30 - 50 amperes continuous current (although significantly greater currents may flow for short periods, under peak load conditions), whereby resistance heating losses are greatly reduced, and whereby inexpensive and simple electrical manufacturing and connection techniques can be employed.

It is a more specific object of the present invention to provide a hybrid drive system for vehicles that does not require the controllable torque-transfer unit shown in the '970 patent, while providing the functional advantages of the hybrid vehicle shown in the '970 patent.

It is a more specific object of the invention to employ the control flexibility provided by the improved hybrid drive train of the invention to allow starting of the engine at comparatively high RPM, while controlling the fuel/air mixture supplied during starting, throttling the engine, and providing a preheated catalytic converter, minimizing emission of unburned fuel and further improving fuel economy.

It is a more specific object of the invention to employ the control flexibility provided by the improved hybrid drive train of the invention to allow employment of a motor producing substantially constant torque up to a base speed, and substantially constant power thereafter, as the engine starting motor, so that torque produced thereby can also be used to propel the vehicle.

In addition to the above objects of the invention, which are similar to those listed in the '817 and '743 applications, the invention of the present continuation-in-part application has as objects the broadening of the useful ranges of loading of vehicles according to the invention, e.g., to provide highly efficient hybrid operation for a vehicle that may weigh 7,000 pounds empty but which can be loaded to weigh 10,000 pounds or more, and may be expected to pull a trailer also weighing 10,000 pounds or more.

A further object of the present invention is to provide further improvements in methods of control of internal combustion engines for hybrid vehicles, to obtain very efficient use of fuel.

Another object of the present invention is to provide an optimal HVAC system for hybrid vehicles.

Still a further object of the invention is to provide a braking system for hybrid vehicles including regenerative braking that provides optimal operator feedback despite changes in operation responsive to the state of charge of the battery bank.

Other aspects and objects of the invention will become clear as the discussion below proceeds.

#### Summary of the Invention

As discussed above, the '970 patent discloses hybrid vehicles wherein a controllable torque transfer unit is provided capable of transferring torque between an internal combustion engine, an electric motor, and the drive wheels of the vehicle. See Figs. 3 - 11 thereof. The direction of torque transfer is controlled by a microprocessor responsive to the mode of operation of the vehicle, to provide highly efficient operation over a wide variety of operating conditions, and while providing good performance. The flow of energy - either electrical energy stored in a substantial battery bank, or chemical energy stored as combustible fuel - is similarly controlled by the microprocessor.

According to one aspect of the invention of the '817 and '743 applications, which is also employed according to the present



continuation-in-part application, the controllable torque-transfer unit shown in the '970 patent is eliminated by replacing the single electric motor shown therein by two separate motors, both operable as generators and as traction motors when appropriate. See Figs. 3 and 4 hereof. As in the '970 patent, an internal combustion engine is provided, sized to provide sufficient torque to be adequate for the range of cruising speeds desired, and is used for battery charging as needed. The internal combustion engine is connected to the drive wheels by a clutch operated by the microprocessor responsive to its selection of the vehicle's mode of operation in response to evaluation of the road load, that is, the vehicle's instantaneous torque demands and input commands provided by the operator of the vehicle. A relatively high-powered "traction" motor is connected directly to the output shaft of the vehicle; the traction motor provides torque to propel the vehicle in low-speed situations, and provides additional torque when required, e.g., for acceleration, passing, or hill-climbing during high-speed driving.

According to the invention of the '817 and '743 applications, a relatively low-powered starting motor is also provided, and can be used to provide torque propelling the vehicle when needed. This second motor is connected directly to the internal combustion engine for starting the engine. Unlike a conventional starter motor, which rotates an internal combustion engine at low speed (e.g., 60 - 200 rpm) for starting, necessitating provision of a rich fuel/air mixture for starting, the starter motor according to the invention spins the engine at relatively high speeds, e.g., 300 - 600 rpm, for starting; this allows starting the engine with a much less fuel-rich fuel/air mixture than is conventional, significantly reducing undesirable emissions and improving fuel economy at start-up. A catalytic converter provided to catalytically combust unburnt fuel in the engine exhaust is preheated to an effective working temperature before starting the engine, further reducing emissions.

In the embodiment discussed in detail, the starting motor is connected directly to the engine, and this combination is connected to the traction motor by a clutch for transfer of torque; the output shaft of the traction motor is then connected to the road wheels of the vehicle. In other embodiments, the engine/starting motor combination may be connected to a first set of road wheels through a clutch, with the traction motor connected to another set of road wheels directly; in a further embodiment, plural traction motors may be provided. In each case, the engine is controllably disconnected from the road wheels by control of the clutch. Engagement of the clutch is controlled by the microprocessor, e.g., controlling an electrical or hydraulic actuator as part of controlling the state of operation of the vehicle in response to the road load.

For example, during low-speed operation, the clutch will be disengaged, so that the engine is disconnected from the wheels; the vehicle is then operated as a "straight" electric car, i.e., power is drawn from the battery bank and supplied to the traction motor. Should the batteries become relatively depleted (e.g., become discharged to 50% of full charge), the starter motor is used to start the internal combustion engine, which then runs at relatively high torque output (e.g., at least about 30% of its maximum torque), for efficient use of fuel, and the starting motor is operated as a high-output generator to recharge the battery bank.

Similarly, when the operator calls for more power than available from the traction motor alone, e.g., in accelerating onto a highway, the starter motor starts the internal combustion engine; when it reaches an engine speed at which it produces useful torque, the clutch is engaged, so that the engine and starter motor can provide additional torque. As noted above, the engine is rotated at relatively high speed for starting, so that the engine rapidly reaches a useful speed.

As in the '970 patent, the engine is sized so that it provides sufficient power to maintain the vehicle in a range of suitable

highway cruising speeds, while being operated in a torque range providing good fuel efficiency; if additional power is then needed, e.g., for hill-climbing or passing, the traction and/or starter motors can be engaged as needed. Both motors can be operated as generators, e.g., to transform the vehicle's kinetic energy into electrical power during descent or deceleration. Also as in the '970 patent, the peak power of the two motors together at least equals the rated power of the engine, as is necessary to provide good performance without employment of a variable-speed transmission or the equivalent.

In each of these aspects of the operation of the vehicle, and as in the '970 patent, the operator of the vehicle need not consider the hybrid nature of the vehicle during its operation, but simply provides control inputs by operation of the accelerator and brake pedals. The microprocessor determines the appropriate state of operation of the vehicle based on these and other inputs and controls the various components of the hybrid drive train accordingly.

It is also within the scope of the invention to operate one or both of the motors at differing rotational speeds than the engine, so that each can be optimized for the demands thereon. More specifically, motors can in general be made smaller if they can be operated at relatively high RPM. Motors operating at up to 9000 - 18,000 RPM appear appropriate for the present application. However, operating the internal combustion engine at this speed would likely lead to undesirable levels of noise and vibration, and might constrain its performance characteristics in an undesirable manner. Accordingly, for example, the starter motor might drive the engine through a pinion geared to a larger toothed flywheel, as conventional. Similarly, it might be desirable to provide the traction motor as a relatively high-speed unit, driving the road wheels through a chain, belt, or gear reduction unit. The starter motor may be configured as a "faceplate" or "pancake" motor, essentially forming the flywheel of the engine, and rotating at

engine speed, while the traction motor is a much higher speed induction motor connected to the vehicle driveshaft by a chain drive reduction unit. It is also within the scope of the invention, as noted above, to operate the engine and the two motors at the same speed when the clutch is engaged, avoiding intermediate gear trains or like mechanical components and the attendant cost, complexity, weight, audible noise, and frictional losses occasioned by their use.

Other improvements provided according to the invention include providing the batteries in two series-connected battery banks, with the vehicle chassis connected to the batteries at a central point, between the banks. This "center-point-chassis" connection reduces the voltage between various circuit components and the vehicle chassis by half, significantly reducing the electrical insulation required and simplifying such issues as heat-sinking of power semiconductors used in the inverter circuitry. Providing dual battery banks and dual electric motors, as above, also provides a degree of redundancy, permitting certain component failures without loss of vehicle function.

In the preferred embodiment, both the traction and starting motors are AC induction motors of four or more phases and the accompanying power circuitry provides current of more than three, preferably five, phases, allowing the vehicle to function even after failure of one or more components. These motors, and the inverter/chargers driving them, should be chosen and operated such that the motors have torque output characteristics varying as a function of rpm as illustrated in Fig. 14 of the '970 patent; that is, the motors should produce substantially constant torque up to a base speed and should produce substantially constant power at higher speeds. The ratio of the base to maximum speed can vary between about 3 to 1 and about 6 to 1. By comparison, the series-wound DC motors conventionally used as engine starting motors provide very high torque, but only at very low speeds; their torque output drops precipitously at higher speeds. Such conventional

starter motors would be unsatisfactory in the present system.

5 During substantially steady-state operation, e.g., during highway cruising, the control system operates the engine at varying torque output levels, responsive to the operator's commands. The range of permissible engine torque output levels is constrained to the range in which the engine provides good fuel efficiency. Where the vehicle's torque requirements exceed the engine's maximum efficient torque output, e.g., during passing or hill-climbing, one or both of the electric motors are energized to provide additional torque; where the vehicle's torque requirements are less than the minimum torque efficiently provided by the engine, e.g., during coasting, on downhills or during braking, the excess engine torque is used to charge the batteries. Regenerative charging may be performed simultaneously, as torque from the engine and the vehicle's kinetic energy both drive either or both motors in generator mode. The rate of change of torque output by the engine may be controlled in accordance with the batteries' state of charge.

20 The vehicle is operated in different modes, depending on its instantaneous torque requirements, and the state of charge of the battery, and other operating parameters. The mode of operation is selected by the microprocessor in response to a control strategy discussed in detail below; the values of the sensed parameters in response to which the operating mode is selected may vary depending on recent history, or upon analysis by the microprocessor of trips repeated daily, and may also exhibit hysteresis, so that the operating mode is not repetitively switched simply because one of the sensed parameters fluctuates around a defined setpoint.

30 None of the implementations of the invention shown in the '970 patent or the '817 and '743 applications include a conventional multi-speed transmission between the motors and engine and the road wheels, and it was stated that a desirable aspect of the invention was to avoid such transmissions, so that the rotational speeds of the two motors and the engine were fixed with

respect to one another, and to the speed of the road wheels. However, it now appears that in some circumstances a two-speed transmission may be desired in some cases to broaden the range of utility of the vehicles of the invention (principally to extend  
5 their load-carrying capabilities) while still providing highly efficient operation, and to include such a two-speed transmission is accordingly part of the invention of the present continuation-in-part application. Such a two-speed transmission could be operated infrequently as a two-speed "range selector", or could be  
10 operated essentially as a conventional automatic transmission, that is, be repetitively shifted during acceleration, upon "kick-down" and the like.

More specifically, it is of great present interest to optimize the hybrid power train of the invention for use with  
15 relatively heavy vehicles, such as vans, pickup trucks and "sport-utility vehicles" (SUVs). Such vehicles have become increasingly popular in recent years, despite their generally poor fuel mileage; it would be highly desirable to provide vehicles with generally similar load-carrying abilities and performance with better fuel economy. Still more particularly, heretofore large classes of such  
20 vehicles have not been subject to certain emission regulations; however, such regulations are expected to take effect shortly. Accordingly, it would be very desirable to provide such vehicles with hybrid power trains that will allow their owners to enjoy the  
25 load-carrying and performance abilities of the existing vehicles with improved fuel economy and reduced emissions.

One of the aspect of SUVs and similar vehicles that must be considered in design of a suitable hybrid powertrain is that their  
30 owners use them to carry and tow widely-varying loads. That is, a conventional SUV might weigh 5,500 pounds, and might typically be used during the week to transport a 140 pound person, up to 300 pounds of children, and 50 pounds of groceries. However, on the weekend the family might load the vehicle with half a ton of camping gear and the like and set off for the mountains towing a

7,500 pound trailer. The vehicle must provide adequate acceleration, passing, and hill-climbing performance in both uses. In order to have sufficient power at times of maximum loading, the vehicle is grossly overpowered under all different circumstances; that is, only when the vehicle is laden to near-maximum capacity and pulling up a long hill does the engine deliver near maximum torque for any length of time. Under all other circumstances, it is run very inefficiently, as noted in connection with Figs. 1 and 2 (reproduced herein from the '970 patent).

An important aspect of the invention as described by the present continuation-in-part application as well as the predecessor applications and the '970 patent lies in controlling the operation of the internal combustion engine of a hybrid vehicle so that it is only operated at high efficiency, that is, only when is it loaded to require a substantial fraction e.g., 30% of its maximum torque output. That is, the engine is never run at less than 30% of maximum torque output ("MTO"). As discussed in the '970 patent and the '817 application, this can be accomplished by sizing the engine so that it can efficiently propel the vehicle unassisted at highway speeds; if additional torque is required for passing or hill-climbing, the traction motor is operated. Application Ser. No. 392,743 further adds the idea of providing a turbocharger, controlled by the microprocessor only to operate when torque in excess of the engine's rated normally-aspirated maximum torque output (MTO) is needed for an extended period of time, for example in towing a trailer. By employing the turbocharger only when actually needed, many of the drawbacks inherent in conventional turbocharger uses are eliminated. Typically the turbocharger may be sized such that the engine provides up to 150% of MTO when turbocharged.

According to one aspect of the invention of the present continuation-in-part application, the range of efficient use of the hybrid vehicle of the invention is further broadened by providing a two-speed transmission between the engine and road wheels, so as

to allow variation in the overall gear ratio and therefore vary the amount of torque available at the wheels. As noted above, this could be a manually- or automatically-operated "range shifting" gearbox akin to those presently provided on SUVs and the like, to allow shifting into a "low range", for example, when a heavy trailer is be towed, or could be operated similarly to a conventional multispeed transmission, that is, to provide a sequence of effective overall gear ratios each time the vehicle is accelerated.

A further improvement made according to the present continuation-in-part application has to do with the braking system. As noted above, the '970 patent (as well as numerous other prior art references) disclose regenerative braking, that is, employing the microprocessor to control the operation of inverter/chargers connected between the motor and battery bank so that when the operator desires to slow the vehicle, its momentum is used to drive the motor in generator mode, charging the battery. There are certain limitations on this as a method of vehicle braking, which must be addressed by any useful vehicle. In particular, a hydraulic braking system of generally conventional design must be provided for several reasons: first, for safety, in the event that the regenerative system fails for any reason; second, to provide braking in the event the battery bank is fully charged and cannot accept further charge (since overcharging is highly detrimental to battery life); and to provide braking when regenerative braking is not available, e.g., when at a standstill. The present application discloses certain improvements in hydraulic braking systems desired to optimize their design for use with hybrid vehicles, as well as a mechanism providing optimized brake "feel" to the driver, regardless whether conventional, regenerative, or both braking systems are in use.

The present application also discloses certain problems inherent in application of conventional vehicles' heating, ventilation and air conditioning systems to hybrid vehicles, and



describes preferred solutions to these problems.

5 A further improvement according to the present invention includes the provision of an auxiliary 12 volt supply system, allowing the hybrid vehicle of the invention to "jumpstart" another vehicle, or likewise to be jumpstarted as might be necessary after a long hiatus, and to allow use of conventional 12 volt accessories, such as radios and other electronic items.

10 The present application also discloses further useful modifications and enhancements to the hybrid vehicles of the predecessor applications.

15 The above and still further objects, features and advantages of the present invention will become apparent upon consideration of the following detailed description of a specific embodiment thereof, especially when taken in conjunction with the accompanying drawings, wherein like reference numerals in the various figures are utilized to designate like components.

#### Brief Description of the Drawings

20 The invention will be better understood if reference is made to the accompanying drawings, in which:

Fig. 1 is a plot of output power versus rotational speed (RPM) for a typical internal combustion engine, illustrating the relative fuel consumption of the engine as used in a conventional automobile in gallons/horsepower-hour;

25 Fig. 2 is a similar plot describing operation of a relatively small internal combustion engine used in the present invention under circumstances similar to those depicted in Fig. 1;

30 Fig. 3 shows a schematic diagram of the principal components of a first embodiment of the hybrid vehicle drive system according to the invention;

Fig. 4 shows a block diagram of the principal components of the drive system of the invention in a second embodiment, differing in certain mechanical arrangements from that of Fig. 3, and illustrating various control signals provided in both embodiments;

Fig. 5 shows a partial schematic diagram of the battery bank, inverter, and motor circuitry;

Fig. 6 is a diagram illustrating differing modes of vehicle powertrain operation, plotted on a three dimensional chart, illustrating that the mode of vehicle operation is a function of the state of charge of the battery bank, the instantaneous road load, and time;

Fig. 7, comprising Figs. 7 (a)-(c), and extending over two sheets, is a timing diagram showing road load, engine torque output, the state of charge of the battery bank, and engine operation as functions of time, thus illustrating a typical control strategy employed during low-speed city driving, highway cruising, and extended high-load driving;

Fig. 8, comprising Figs. 8 (a)-(d), are diagrams indicating the flow of torque and of energy among the components of the hybrid powertrain of the invention, in various modes of operation;

Fig. 9 is a simplified flow chart of the algorithm employed by the microprocessor to implement the control strategies provided by the vehicle according to the invention;

Fig. 9(a) is a flow chart of an engine starting subroutine employed in the flowchart of Fig. 9;

Fig. 9(b) is an alternate version of one of the steps of the flowchart of Fig. 9, implementing a modification to the vehicle control strategy;

Fig. 9(c) is an alternate version of another of the steps of the flowchart of Fig. 9, similarly implementing a modification to the vehicle control strategy;

Fig. 10 illustrates the preferred torque versus speed characteristics of the electric starting and traction motors, and of the internal combustion engine;

Fig. 11 is a schematic diagram similar to Fig. 3, illustrating an alternative embodiment of the hybrid vehicle powertrain according to the invention, wherein the engine is provided with a turbocharger which is controllably operable, so as to be employed

only when needed;

Fig. 12 is a three-dimensional diagram comparable to Fig. 6, showing the modes of operation of the turbocharged hybrid vehicle of Fig. 11;

Fig. 13 is a timing diagram similar to Fig. 7, again comprising Figs. 13(a) - (c), extending over two sheets, and illustrating typical operation of the turbocharged hybrid vehicle of Fig. 11;

Fig. 14 is a schematic diagram similar to Figs. 3 and 11, illustrating a further alternative embodiment of the hybrid vehicle powertrain according to the invention, wherein a second traction motor is connected to a second set of road wheels, providing a particularly convenient way of providing four-wheel drive;

Fig. 15 is a schematic diagram of the preferred brake system of a hybrid vehicle according to the invention; and

Fig. 16 is a is a schematic diagram of the preferred heating, ventilation and air conditioning system of a hybrid vehicle according to the invention.

#### Description of the Preferred Embodiments

Referring specifically to Fig. 1, which is reproduced here from the '970 patent for convenience, curve 10 represents the output power versus engine speed (RPM) of a typical spark ignition gasoline-fueled internal combustion engine as used with an automatic transmission in a typical sedan of 3,300 pounds. As can be seen, the maximum engine power available is about 165 horsepower at about 5,000 RPM. Also shown in Fig. 1 by the curve labeled "Large Car Average Power Requirements" are the average power requirements of such a vehicle. Points C, S, and H on this curve show average fuel consumption in city, suburban, and highway driving, respectively; in particular, point C shows that the average power required in typical city driving is less than 5 hp. Point S shows that the average power consumed in suburban driving is 10 hp, and point H shows that the power needed for steady-speed

highway driving is only about 30 hp. Thus, the vehicle is vastly overpowered at all times except during acceleration or hill-climbing.

Fig. 1 also includes dashed-line curves indicating the relative fuel consumption of the engine. As can be seen, reasonable fuel efficiency, that is, at least about 105 percent relative fuel consumption (100% being ideal), is reached only when the engine is operated at between about 2,000 and 4,000 RPM, and when producing between about 75 and 150 horsepower. Fig. 1 thus indicates that the typical internal combustion engine is operated with reasonable efficiency only when producing between about 50 and about 90% of its maximum output power. The typical automobile only requires such substantial power under conditions of extreme acceleration or hill climbing.

Accordingly, it will be appreciated that the typical engine is operated efficiently only during relatively brief intervals; more specifically, at lower power outputs, losses due to friction and pumping consume larger fractions of the engine's total torque, so that a lower fraction is available to propel the vehicle. As can be seen, during typical highway driving, shown by point H, the relative fuel consumption is on the order of 190 percent of that required during the most efficient operation of the engine. The situation is even worse in suburban driving, where the relative fuel consumption is nearly 300 percent of the most efficient value, and in city driving, where the relative fuel consumption is almost 350 percent of that required at most efficient operation.

Fig. 1 thus demonstrates that an internal combustion engine having sufficient horsepower for adequate acceleration and hill climbing capability must be so oversized with respect to the loads encountered during most normal driving that the engine is grossly inefficient in its consumption of fuel. As noted, Fig. 1 further shows that only about 30 horsepower is needed to cruise on the highway even in a relatively large car.

Fig. 2 (again reproduced from the '970 patent for convenience)

is similar to Fig. 1, and illustrates the operational characteristics of the same 3,300 pound car if driven by a relatively small engine having a maximum horsepower rating of about 45 horsepower at 4,000 RPM. The power requirement of the vehicle during highway cruising, shown by point H on the curve marked "Large Car Average Power Requirements", is in the center of the most efficient region of operation of the engine. However, even with this small engine thus optimized for highway cruising, there is a substantial gap between the "Engine Operating Power" curve and the Average Power Requirement curve 14. That is, even this small engine produces substantially more power at low RPM than needed for city driving (point C) or for suburban driving (point S). Accordingly, even with a small engine sized appropriately for highway cruising, substantial inefficiencies persist at lower speeds. Moreover, of course, such a vehicle would have unsatisfactory acceleration and hill climbing ability. Therefore, the answer is not simply to replace large internal combustion engines with smaller internal combustion engines.

The prior art recognizes that there are substantial advantages to be gained by combining the virtues of a gasoline or other internal combustion engine with those of an electric motor running from a battery charged by the internal combustion engine. However, the prior art has failed to provide a solution which is directly price- and performance-competitive with vehicles now on the market; moreover, in order that such a vehicle can be commercially successful, it must also be no more complex to operate than existing vehicles.

As indicated above, "straight" electric vehicles, that is, vehicles having electric traction motors and batteries requiring recharge at the end of each day's use, do not have sufficient range and require too much time to recharge to fully replace conventional automobiles. Further, the operational costs of such vehicles are not competitive with internal combustion vehicles operated on fuels derived from renewable resources such as ethanol, and are even less

competitive with gasoline-fueled automobiles.

5 A first type of series hybrid vehicles, involving a gasoline engine driving a generator charging a battery powering an electric traction motor, are limited in acceleration and hill climbing ability unless the electric motor is made very large, costly, and bulky. The alternative series hybrid approach, involving a transmission between a relatively smaller electric motor and the wheels to provide the torque needed to accelerate quickly, loses the virtue of simplicity obtained by elimination of a multi-speed transmission. These vehicles fail to realize the advantages provided by the parallel hybrid system in which both an internal combustion engine and an electric motor provide torque to the wheels as appropriate.

10 However (apart from the '970 patent) the prior art relating to parallel hybrid vehicles fails to disclose a system sufficiently simple for economical manufacture. The art further has failed to teach the optimum method of operation of a parallel hybrid vehicle. Moreover, the art relating to parallel hybrids (again, apart from the '970 patent) does not teach the appropriate operational parameters to be employed, relating to the relative power outputs of the internal combustion engine and the electric motor; the type of electric motor to be employed; the frequency, voltage, and current characteristics of the motor/battery system; the proper control strategy to be employed under various conditions of use; and combinations of these.

25 As shown in the '970 patent with reference to Figs. 1 and 2 thereof, and again above, typical modern automobiles operate at very low efficiency, due principally to the fact that internal combustion engines are very inefficient except when operating at near peak torque output; this condition is only rarely met. (The same is true, to greater or lesser degree, of other road vehicles powered by internal combustion engines.) According to an important aspect of the invention of the '970 patent, substantially improved efficiency is afforded by operating the internal combustion engine

only at relatively high torque output levels, typically at least 35% and preferably at least 50% of peak torque. When the vehicle operating conditions require torque of this approximate magnitude, the engine is used to propel the vehicle; when less torque is required, an electric motor powered by electrical energy stored in a substantial battery bank drives the vehicle; when more power is required than provided by either the engine or the motor, both are operated simultaneously. The same advantages are provided by the system of the present invention, with further improvements and enhancements described in detail below.

According to one aspect of the invention of the '970 patent, the internal combustion engine of a hybrid vehicle is sized to supply adequate power for highway cruising, preferably with some additional power in reserve, so that the internal combustion engine operates only in its most efficient operating range. The electric motor, which is substantially equally efficient at all operating speeds, is used to supply additional power as needed for acceleration and hill climbing, and is used to supply all power at low speeds, where the internal combustion engine is particularly inefficient, e.g., in traffic.

As indicated above, this application discloses certain modifications, improvements, and enhancements of the hybrid vehicles shown in U.S. patent 5,343,970; where not otherwise stated, the design of the vehicle of the present invention is similar to that shown in the '970 patent. Components commonly numbered in this application and the '970 patent are functionally similar, with detail differences as noted. The advantages of the system shown in the '970 patent with respect to the prior art are provided by that of the present invention, with further improvements provided by the latter, as detailed herein.

In the system of the '970 patent, torque from either or both the engine and motor is transferred to the drive wheels of the vehicle by a controllable torque-transfer unit. This unit also allows torque to be transferred between the motor and engine, for

starting the engine, and between the wheels and motor, for regenerative battery charging during deceleration of the vehicle. This unit, while entirely practical, comprises gears for power transfer, which are inevitably a source of audible noise and frictional losses. According to one aspect of the present invention, the controllable torque-transfer unit is eliminated. Instead, two electric motors are provided, each separately controlled by a microprocessor controller responsive to operator commands and sensed operating conditions.

In this connection, it will be understood that the terms "microprocessor" and "microprocessor controller" are used interchangeably throughout the present application, and it is to be further understood that these terms as used herein include various types of computerized control devices not always referred to as "microprocessors" per se, such as computers themselves incorporating microprocessors, digital signal processors, fuzzy logic controllers, analog computers, and combinations of these. In short, any controller capable of examining input parameters and signals and controlling the mode of operation of the vehicle according to a stored program, as discussed below in detail, is considered to be a "microprocessor" or "microprocessor controller" as used herein. Furthermore, the electronic fuel injection and electronic engine management devices shown in Figs. 3 and 4 as separate elements might also be integrated within the "microprocessor" or "microprocessor controller" as described herein.

Fig. 3 of the present application shows a first embodiment of the present invention, while Fig. 4, discussed below, shows a second embodiment illustrating certain alternative mechanical arrangements; overall the two embodiments are very similar, and functionally they are substantially identical. Fig. 11, also discussed below, illustrates a further embodiment, and Fig. 14 incorporates still further improvements.

In the Fig. 3 embodiment, a traction motor 25 is connected



directly to the vehicle differential 32, and thence to the road wheels 34. A starting motor 21 is connected directly to the internal combustion engine 40. The motors 21 and 25 are functional as motors or generators by appropriate operation of corresponding inverter/charger units 23 and 27, respectively, connected between the motors and battery bank 22. At present, essentially conventional lead-acid batteries are preferred for battery bank 22, since these are widely available and well understood. More advanced batteries may be used if and when they become widely available and economically competitive.

Motors 21 and 25 are controllably connected for torque transfer by a clutch 51, mechanically interlocking the shafts 15 and 16 of motors 21 and 25 respectively. As discussed further below in connection with Fig. 4, microprocessor (" $\mu$ P") 48 is provided with signals indicative of the rotational speeds of shafts 15 and 16, and controls operation of engine 40, motor 21, and motor 25 as necessary to ensure that the shafts are rotating at substantially the same speed before engaging clutch 51. Accordingly, clutch 51 need not necessarily be an ordinary automotive friction clutch (as illustrated schematically in Fig. 1), as conventionally provided to allow extensive relative slipping before the shafts are fully engaged. More particularly, as slipping of clutch 51 is not required to propel the vehicle initially from rest, as is the case in conventional vehicles, clutch 51 need not allow for extensive slipping when being engaged. In some cases it may be satisfactory to provide clutch 51 as a simple self-aligning mechanical interlock (as shown in Fig. 4), wherein positive mechanical connection is made between the shafts 15 and 16 upon engagement. Such a mechanical interlock is much simpler and less expensive than a friction clutch. In either case, clutch 51 is operated by microprocessor 48, e.g., through a known electric or hydraulic actuator 53, together with the other components of the system, in accordance with the operational state of the vehicle and the operator's input commands.

The respective positions of motor 21 and engine 40 with respect to clutch 51, motor 25, and wheels 34 could be reversed as compared to their positions in Figs. 3 and 4 without affecting the function of the system, although as engine 40 would then require torque transmitting connection at both ends of its crankshaft, some additional complexity would result.

As shown in Fig. 4, shaft encoders 18 and 19 may be mounted on the shafts 15 and 16 of starting motor 21 and traction motor 25, respectively, to provide signals to microprocessor 48 indicative of the relative rotational speeds of the shafts, and their respective rotational positions. Such shaft encoders are well-known and commercially available. Alternatively, signals indicative of the rotational speeds of the shafts may be derived from the inverter control signals, in accordance with well-known principles of control of "sensorless" motor drives (see, for example, Bose, "Power Electronics and Variable Frequency Drives", IEEE, 1996). However, provision of encoders 18 and 19 will allow better low-speed torque characteristics of motor 21 and 25, and thus reduction in cost.

Thus being provided with signals indicative of the rotational speeds of shafts 15 and 16, microprocessor 48 controls operation of engine 40, motor 21, and motor 25 as necessary to ensure that the shafts are rotating at substantially the same speed before engaging clutch 51; therefore, clutch 51 need not be an ordinary automotive friction clutch (as illustrated schematically in Fig. 3), as conventionally provided to allow extensive slipping before the shafts are fully engaged. According to this aspect of the invention, and particularly if microprocessor 48 is made capable of ensuring that shafts 15 and 16 bear a desired relative angular relationship, clutch 51 instead may be a simple, relatively inexpensive self-aligning mechanical interlock (as illustrated schematically in Fig. 4), wherein positive mechanical connection is made between the shafts 15 and 16 upon engagement.

Fig. 4 also shows additional signals provided to

microprocessor 48 in both the Fig. 3 and the Fig. 4 embodiments. These include operator input commands, typically acceleration, direction, deceleration, and "cruise mode" commands, as shown. The acceleration and deceleration commands may be provided by position-sensing encoders 71 and 72 (Fig. 3)(which could be configured as rheostats, Hall-effect sensors, or otherwise) connected to microprocessor 48 by lines 67 and 68, to inform the microprocessor of the operator's commands responsive to motion of accelerator and brake pedals 69 and 70 respectively. The microprocessor monitors the rate at which the operator depresses pedals 69 and 70 as well as the degree to which pedals 69 and 70 are depressed. The operator may also provide a "cruise mode" signal, as indicated, when a desired cruising speed has been reached. The microprocessor uses this information, and other signals provided as discussed herein, in accordance with the operational strategy discussed in detail below in connection with Figs. 6 - 9, to properly control operation of the vehicle according to the invention by appropriate control signals provided to its various components.

For example, suppose the vehicle has been operated in city traffic for some time, that is, under battery power only. Typically the operator will only depress the accelerator pedal 69 slightly to drive in traffic. If the operator then depresses accelerator pedal 69 significantly farther than he or she had, for example, the prior few times acceleration was required, this may be taken as an indication that an amount of torque that can efficiently be provided by engine 40 will shortly be required; microprocessor will then initiate the sequence whereby starting motor 21 will be used to start engine 40.

Upon initiation of the engine starting sequence, a heater 63 (Fig. 3) will first be used to preheat a catalytic converter 64 provided in the engine exhaust system 62, so that any fuel that is not combusted during starting and subsequent running of the engine 40 will be catalytically combusted, reducing emission of

undesirable pollutants. A temperature sensor 102 is preferably provided, so as to ensure the engine is not started until the catalytic material is heated to effective working temperature. As noted above, engine starting is preferably performed with the engine turning at a higher speed than is conventional, so that a the fuel/air ratio need only be slightly (e.g., 20%) richer than stoichiometric. As a result, only very limited amounts of pollutants are emitted during engine starting. By comparison, in conventional vehicles, a very significant fraction of the total pollutants emitted during any given trip are emitted during the first 30 - 60 seconds of operation, due to the extremely rich mixtures normally supplied during starting, and to the ineffectiveness of the catalyst until it has been heated by the exhaust.

If the operator depresses the pedal 69 rapidly, indicating an immediate need for full acceleration, the preheating step may be omitted; however, a preferable alternative may be to allow the traction and starting motors to be driven at or slightly beyond their rated power, providing adequate torque, for a short time sufficient to allow the catalyst to be warmed and the engine started.

Similarly, if the operator depresses the brake pedal 70 relatively gently, all braking may be provided by regenerative charging of the batteries; if the operator instead presses aggressively on brake pedal 70, and/or presses brake pedal 70 beyond a predetermined point, both mechanical and regenerative braking will be provided. Mechanical braking is also provided on long downhills when the batteries are fully charged, and in case of emergency. Further aspects of the preferred brake system of the hybrid vehicles of the invention are added by the present continuation-in-part application, and are discussed below.

In addition to engine and starting motor speed and traction motor speed, monitored by shaft encoders 18 and 19 as discussed above, battery voltage, battery charge level, and ambient

temperature are also either monitored directly or derived from monitored variables. In response to these inputs, and the operator inputs, microprocessor controller 48 operates a control program (see the high-level flowchart of an exemplary control program provided as Fig. 9), and provides output control signals to engine 40, by commands provided to its electronic fuel injection unit (EFI) 56 and electronic engine management system (EEM) 55, and to starting motor 21, clutch 51, traction motor 25, inverter/charger units 23 and 27, and other components.

As indicated in Fig. 4, the control signals provided to inverter/chargers 23 and 27 by microprocessor 48 allow control of the current (represented as  $I$ ), of the direction of rotation of the motor 25 (represented as +/-), allowing reversing of the vehicle, and of the frequency of switching (represented as  $f$ ), as well as control of operation of the motors 21 and 25 in motor or generator mode. Inverter/chargers 23 and 27 are separately controlled to allow independent operation of motors 21 and 25. Inverter/charger operation is discussed further below in connection with Fig. 5.

As noted above, the Figs. 3 and 4 embodiments of the system of the invention differ in certain mechanical arrangements, intended to illustrate variations within the scope of the invention, and Fig. 4 also provides more detail concerning the specific control signals passing between various elements of the system.

Referring to the differing mechanical arrangements, it will be observed that in Fig. 3 the shafts of motors 21 and 25 are illustrated as coaxial with that of engine 40; this is the simplest arrangement, of course, but would require the engine 40 and starter motor 21 to rotate at the same speed at all times, and at the same speed as traction motor 25 when clutch 51 is engaged. As noted above, it may be preferable to design motors 21 and 25 to have maximum speeds of 9000 - 15,000 rpm, so that they could be made smaller, lighter, and less costly than slower-rotating motors. However, it is envisioned that a preferred maximum speed for

engine 40 is 6000 rpm, as internal combustion engines running at substantially higher speeds wear rapidly and tend to have limited torque at low speed, and because higher frequency engine noise and vibration can also be difficult to absorb. It is within the scope of the invention to provide the motors coaxial with the engine shaft, as illustrated in Fig. 3, but to provide a planetary gearset(s) between the shafts of either or both of traction motor 25 and starting motor 21 and the output shaft to permit differing engine and motor speeds. Further alternatives to this aspect of the invention are again added by the present continuation-in-part application, and are discussed below.

Fig. 4 illustrates an alternative construction, also permitting differing engine and motor speeds. In this case, the output shaft of starting motor 21 is shown connected to that of engine 40 by spur gears 52, and traction motor 25 is connected to the output shaft 55 by chain drive indicated at 54. Numerous other arrangements will occur to those of skill in the art. However, in each case there is no variable-ratio transmission between the sources of torque -- that is, the motors 21 and 25, and the engine 40 -- and the road wheels 34. Again, further alternatives to this aspect of the invention are added by the present continuation-in-part application, and are discussed below.

It is also within the scope of the invention to connect the traction motor to one set of wheels, and to connect the combination of the engine 40 and starting motor 21 to another set of wheels through clutch 51, thus providing a four-wheel drive vehicle with differing power sources for the alternate pairs of wheels. In this embodiment, the torque from the traction motor 25 is effectively combined with that from engine 40 (and from starting motor 21, when used as a source of propulsive torque) by the road surface, rather than by mechanical connection, as in the Figs. 3 and 4 embodiment. A further alternative would be to provide a complete system as in Fig. 3 driving one pair of road wheels, and a separate traction motor driving a second pair of road wheels.

Both embodiments are within the scope of the invention, and the control strategy is essentially the same as to both. See Fig. 14 and the related text below for further discussion.

Other elements of the system as illustrated in Figs. 3 and 4 are generally as discussed in the '970 patent, including supply of fuel 36 from tank 38, air filter 60, and throttle 61.

Control of engine 40 by microprocessor 48 is accomplished by way of control signals provided to electronic fuel injection (EFI) unit 56 and electronic engine management (EEM) unit 55, responsive to throttle operation; preferably, the throttle in turn is operated electronically responsive to the operator's depression of the accelerator pedal. Control of starting of engine 40, and using either or both of starting motor 21 and traction motor 25 as motors, providing propulsive torque, or as generators, providing recharging current to battery bank 22, is accomplished by microprocessor 48 by way of control signals provided to inverter/charger units 23 and 27.

Under deceleration, for example, during descents, or as needed for braking, or when the engine's instantaneous torque output exceeds the vehicle's current torque requirements, either or both of motors 21 and 25 are operated as generators, providing regenerative recharging of battery bank 22. Fig. 7, discussed below, illustrates this aspect of the operation of the vehicle of the invention in further detail.

Thus, as indicated above, when microprocessor 48 detects a continued operator requirement for additional power, such as during transition from slow-speed to highway operation, or by measuring the rate at which the operator depresses accelerator pedal 69, engine 40 is started using starter motor 21 and brought up to speed before clutch 51 is engaged, to ensure a smooth transition. As cruising speed is reached (as determined by monitoring the operator's commands), power to traction motor 25 (and to starter motor 21, if also used to accelerate the vehicle) is gradually reduced. Provision of the clutch 51 and separate starter motor 21,

as compared to using the single traction motor to start engine 40 while simultaneously accelerating the vehicle, that is, as in the '970 patent, simplifies the control arrangements somewhat.

In one possibly preferred embodiment, both motors 21 and 25 and clutch 51 may be provided in a single sealed housing, possibly bathed in oil for cooling and protection from dust and the like. It is also known to control auxiliary motors, such as conventional starter motors, to absorb or add torque to that provided by an associated internal combustion engine, to damp out vibration caused by fluctuation of the torque provided by the engine; doing so herein using either or both of motors 21 and 25 is within the scope of the invention, and is simplified by virtue of the direct connection of the engine 40 to the drive wheels through motors 21 and 25 according to the invention.

Provision of the clutch 51 and separate starter motor 21 also allows another important improvement to be provided according to the present invention, namely starting engine 40 at high speed, e.g., about 300 - 600 rpm, as compared to the 60 - 200 rpm starts conventionally provided. As is generally known in the art (see Simanaitis, "What goes around comes around", *Road & Track*, November 1998, p. 201) high-rpm starting allows substantial elimination of the usual necessity of providing a fuel-rich air/fuel mixture to start engine 40, reducing emission of unburned fuel and improving fuel economy at start-up, particularly from cold.

More particularly, in conventional low-rpm starts, a rich mixture comprising up to on the order of 6 to 7 times the stoichiometric amount of fuel is provided, to ensure that some fraction of the fuel is in the vapor phase, as only fuel in the vapor phase can be ignited by a spark. Most of the excess fuel condenses as liquid on the cold cylinder walls, and thus does not burn efficiently, if at all, and is immediately emitted unburned. By comparison, at high starting speeds according to the invention, turbulence in the combustion chamber is sufficient to ensure the presence of vapor, so that a near-stoichiometric mixture, typically



including only 1.2 times the stoichiometric amount of fuel, can be provided to engine 40 during the starting phase. The avoidance of rich mixtures at starting significantly reduces emission of unburned fuel - since most of the fuel provided to a conventional engine at starting is immediately exhausted unburnt - and provides some improvement in overall fuel efficiency.

Furthermore, as noted above, whenever possible - that is, whenever the engine is started except when immediate full torque is required by the operator - a catalytic converter 64 is preheated to an effective working temperature of at least about 350° C before starting the engine, to prevent even this relatively small emission of unburned fuel.

Thus, the primary consideration in selecting the torque of starting motor 21 is that it be capable of rotating the engine 40 at about 300 - 600 rpm for starting, and that it be capable of accepting at least about 30% of the engine's maximum torque output when operated as a generator, so that the engine can be efficiently employed when charging the battery bank during extended low-speed operation; the main consideration in specification of the torque of engine 40 is that it provides sufficient power for highway cruising while being operated at high efficiency, i.e., that its maximum power output be sufficient to cruise in a range of desired cruising speeds; and the principal consideration defining the power required of the traction motor 25 is that it be sufficiently powerful to provide adequate acceleration in combination with the engine 40 and starting motor 21. Stated differently, the total power available provided by all of these torque-producing components should be at least equal to and preferably exceeds the peak power provided by the internal combustion engines of conventional vehicles of similar intended use, both as measured at the wheels. Moreover, as set forth in the '970 patent, the total torque provided by motors 21 and 25 should be at least equal to that produced by engine 40, in order to provide adequate low-speed performance under motor alone, and

without necessity of a variable-ratio transmission.

At the same time, motors 21 and 25 are also sized to be capable of recovering almost all of the vehicle's kinetic energy when operated as generators in the regenerative braking mode. A particularly high fraction of the vehicle's kinetic energy can be recovered during low-speed operation; as compared to high-speed operation, where air resistance and road friction consume a relatively large fraction of the total energy required, in low speed operation much energy is lost by conventional vehicles as heat released during braking.

Given the above considerations, the following are typical power specifications for the engine 40, starting motor 21 and traction motor 25 of a 3000 pound vehicle having performance approximately equivalent to that of a "mid-size" sedan of United States manufacture. It should be understood that in these specifications, reference is made to the rated power produced continuously by the engine, not to the rated peak power of the motors, as is generally conventional in the art. Further, the motors are specified assuming the direct-drive embodiment of Fig. 3; if the motors run at higher speeds, their ratings would be determined accordingly.

Engine 40: 40 to 50 horsepower at 6000 rpm

Starting motor 21: 10 - 15 horsepower at approximately 1500 rpm and higher speeds

Traction motor 25: 50 - 75 horsepower from 1500 to 6000 rpm.

The same starting motor would be satisfactory for a larger, 4000 pound sedan, but the engine would typically provide 70 - 90 horsepower at 6000 rpm and the traction motor 75 - 100 horsepower.

In both cases, the total power available from the electric motors together should equal, and preferably exceeds, the maximum power available from the engine.

In the hybrid vehicle of the invention, which as noted does not require a complex, heavy, and costly variable-ratio transmission, these components would provide acceleration much

superior to that of typical similarly-sized automobiles of United States manufacture, together with far better fuel economy and substantially reduced emission of pollutants. It will be apparent that these specifications may vary over relatively wide ranges depending on the intended use of the vehicle of the invention, and should not be construed to limit the scope of the invention.

As indicated above, in the preferred embodiment, both the starting and traction motors are AC induction motors, although other types may also be employed. These motors, and the inverter/chargers controlling them in response to control signals from the microprocessor (as discussed further below), should be chosen and operated such that the motors have torque output characteristics varying as a function of rpm as illustrated by curve A in Fig. 10. That is, the motors are operated by the inverter/chargers, in response to control signals from the microprocessor, so as produce constant torque up to a base speed C, typically 1500 rpm for a motor having a top speed of 6000 rpm, as employed in the direct-drive embodiment of Fig. 3, and should produce constant power at higher speeds; accordingly, the torque drops off at speeds above the base speed C, as shown. The ratio of the base to maximum speed, 4 : 1 in this example, can vary between about 3 to 1 and about 6 to 1. This torque output characteristic essentially allows the vehicle of the invention to provide quite acceptable performance, especially acceleration, without the weight, complexity and cost of a variable-ratio transmission.

By comparison, the series-wound DC motors conventionally used as automotive engine starting motors provide very high torque, but only at very low speeds; their torque output drops precipitously at higher speeds. Such conventional starter motors would be unsatisfactory in the present system.

Fig. 10 also shows the torque curve of a typical internal combustion engine at B; as noted, the torque is zero at zero rpm, so that a clutch allowing slippage is required to allow the engine to move the vehicle from rest. Fig. 10 shows at D typical curves

for torque as measured at the wheels of a vehicle propelled by a typical internal combustion engine driving the vehicle through a four-speed transmission, used to provide additional torque at low speeds; the vertical spaces between sections of curve D represent changes in gear ratio, that is, the vehicle will be shifted to move between the sections of curve D. As shown by Fig. 10, the desired torque characteristics of the starting and traction motors discussed above allow the vehicle of the invention to provide low-speed performance comparable to or better than a conventional vehicle, while eliminating the necessity of a variable-ratio transmission. However, as discussed further below, it is within the invention of the present continuation-in-part application to extend the load-carrying capabilities of the hybrid vehicle of the invention by also providing a variable-ratio, e.g., two-speed, transmission, where not excluded by the appended claims. This should not be necessary with respect to passenger cars.

The ratio between the base speed and maximum speed of the motors as used according to the invention is thus comparable to the ratio between the lowest and highest gears of a conventional transmission; for passenger cars, the latter ratio is typically between 3 and 4 : 1, so that the engine's torque is relatively well matched to the road load over a reasonable range of road speeds.

As discussed above, while it is within the scope of the invention to operate the motors 21 and 25 and the internal combustion engine 40 at the same maximum speed, so that no gearing is required to couple these elements, it is presently preferred that at least traction motor 25 have a maximum speed substantially higher than that of the internal combustion engine 40; the output shaft of motor 25 can be connected to the road wheels by a chain-drive reduction unit, as indicated in Fig. 4. The maximum speed of the internal combustion engine is preferably limited to on the order of 6000 rpm to limit wear, noise and vibration, which increase with higher operating speeds, and because engines capable of higher-rpm operation tend to have narrow ranges of rpm within

which they produce substantial torque; the latter characteristic would be undesirable in a vehicle not having a variable-ratio transmission and intended to cruise powered solely by the internal combustion engine, according to the invention.

5 By comparison, operating the motors 21 and 25 at maximum speeds of 9000 - 18,000 rpm allows them to be made smaller, lighter, and less costly; whether this advantage overcomes the added complexity of chain, gear, or belt drives, or other mechanical means allowing combination of torque from the motors with that from the engine, is a matter of engineering choice that 10 may vary from one model of vehicle to the next. Both are accordingly within the present invention. If each of the torque-producing components (that is, engine 40 and starting and traction motors 21 and 25) is to be operated at the same speed, a maximum 15 speed of approximately 6000 rpm is preferred, as this represents a good compromise between cost, weight, and size of the key components.

As discussed above, it is preferred that motors 21 and 25 have more than two poles, and be operated by current applied over more 20 than three phases, so that failure of some components - such as the power semiconductors used in the inverter/charger units, as discussed below - can be tolerated without total failure of the vehicle. It is also desired that the battery bank be divided into two, with the vehicle chassis connected between them, halving the 25 voltage between given components and the vehicle chassis, and thus simplifying their construction, insulation, and connection. Fig. 5 shows a partial schematic diagram of a circuit providing these attributes.

30 The functions of the inverter/chargers 23 and 27 (separate inverter/chargers being required to allow independent operation of motors 21 and 25) include control of motors 21 and 25 to operate as motors or as generators; operation of traction motor 25 in the opposite direction for reversing the vehicle; conversion of DC stored by the battery bank to AC for motor operation; and

conversion of AC induced in the motors when operated as generators to DC for battery charging. Essentially similar functions were provided by the solid-state switching AC/DC converter 44 in the '970 patent; where not specified to the contrary, the discussion thereof is applicable to the inverter design shown in Fig. 5 hereof.

As illustrated in Fig. 5, traction motor 25 is embodied as a five-phase AC induction motor; starting motor 21, which is not fully illustrated, as indicated, can be but is not necessarily generally similar. Other motor types, such as permanent magnet brushless DC motors or synchronous motors, might also be employed. The motors are operated as multiphase devices, having three phases or more, permitting employment of smaller and overall less costly semiconductors, and allowing operation even if some of the semiconductors fail. Use of motors operated at relatively high frequency, e.g., more than 60 Hz, also permits motors of a given power output to be smaller. As shown in Fig. 5, it is currently preferred that at least traction motor 25 be wired in the "wye" arrangement shown, rather than the known "delta" arrangement; it is found that certain undesirable harmonics are reduced by the "wye" arrangement. Both are well known in the art, and within the scope of the invention.

As illustrated in Fig. 5, each of the windings 78 of motor 25 is connected to a pair of semiconductor switching elements 80 collectively making up inverter/charger 27. Inverter/charger 27 is correspondingly configured as a set of ten power semiconductors 80 controlled by switching signals A through J provided by a pulse generator 88 responsive to frequency, polarity and current signals received from microprocessor 48 (Figs. 3 and 4). Typical operating frequencies can be up to 200, 400 or 600 Hz; the transfer of power between the battery bank 22 and motors 21 and 25 is then controlled by pulse-width modulation, that is, by controlling the semiconductors 80 to conduct during portions of the power waveform, the duration of the conducting portions varying in

accordance with the power required. Semiconductors 80 may be any type suitable for handling relatively high voltages and currents; satisfactory insulated-gate bipolar transistors (IGBTs) are currently available and are presently preferred. As conventional, each of the semiconductors 80 is paralleled by a freewheeling rectifier diode 82.

Design of the inverter/chargers 23 and 27 and of pulse generator 88 to provide suitable control signals A through T so that the inverter/chargers perform the functions listed above is within the skill of the art; again, see, for example, Bose, "Power Electronics and Variable Frequency Drives", IEEE, 1996.

The current drawn from the battery bank 22 during long-term operation of the traction and starting motor(s) to propel the vehicle should be limited to 30 - 50 amperes, to reduce the size of the conductors and other components required, as discussed in the '970 patent; these components are satisfactory to carry currents of up to 200 amperes, as may be encountered during full-power acceleration, as this condition will not persist for more than about 30 seconds.

As indicated, the battery bank 22 comprises two substantially similar battery assemblies 84; in one embodiment, each battery assembly will comprise eight 48-volt batteries, such that 384 volts is provided by each. The battery assemblies 84 are connected in series, so that 768 volts are provided across the circuit "rails" 86, 88. However, the vehicle chassis connection is taken from between the series-connected battery assemblies, so that only 384 volts is present between any given circuit component and the vehicle chassis; this "center-point-chassis" connection significantly reduces various insulation and heat-sinking requirements. More specifically, the conductors, connectors, relays, switches and like elements can be as approved by the National Electrical Manufacturers' Association (NEMA) for 600 volt service; such elements are widely available, and are much more easily employed and much less expensive than those needed for

continuously carrying current at, for example, 300 volts and 300 amperes.

5 Preferably, as indicated by Fig. 5(a), illustrating a detail of a portion of one of the battery assemblies 84, the 48-volt batteries 85 are connected by normally-open relays 87, so that the batteries 85 are isolated from one another under fail-safe conditions; for example, if the vehicle is involved in an accident, power to the relays is cut off, so that the maximum open voltage anywhere in the vehicle is 48 volts, reducing the danger of fire. 10 Similarly, the relays open when the vehicle's "ignition" is shut off by the operator.

The present continuation-in-part application adds to the above from the '817 application that an auxiliary 12-volt system may also be provided, as shown at 223 in Fig. 14, discussed further below. 15 This would be a DC-to-DC converter, allowing the vehicle to provide "jumping" current to start other vehicles having conventional 12-volt electrical systems, and would also allow the vehicle of the invention to be jumpstarted similarly, if necessary. Provision of a 12-volt system also allows convenient employment of conventional 20 automotive accessories, such as radios and the like. The 12-volt system could perhaps most conveniently be implemented by a separate semiconductor-implemented voltage conversion circuit, transforming the 48 volts from one of the batteries to 12 volts for jumping others, and providing the inverse 12 to 48 volt transformation as needed. It should also be understood that the individual batteries 25 could be 42 volt units, conforming to the apparent trend toward 42 volt systems for new vehicles. Further preferably, the entire battery bank assembly, including the relays, is enclosed in a rugged container, significantly reducing the danger of electrical shock and the like. 30

Turning now to detailed discussion of the inventive control strategy according to which the hybrid vehicles of the invention are operated: as in the case of the hybrid vehicle system shown in the '970 patent, and as discussed in further detail below, the



vehicle of the invention is operated in different modes depending on the torque required, the state of charge of the batteries, and other variables. Throughout, the object is to operate the internal combustion engine only under circumstances providing a significant load, thus ensuring efficient operation. In the following, the relationships between these modes are illustrated using several different techniques, to ensure the reader's full understanding of various aspects of the vehicle control strategy; some of these are seen more clearly in one form of illustration than another.

Fig. 6 illustrates the several modes of vehicle operation with respect to the relationship between the vehicle's instantaneous torque requirements or "road load", the state of charge of the battery bank 22, and time, while Fig. 7 shows variation in, and the relationship between, road load, engine torque output, and the state of charge of the battery bank over time, that is, during an exemplary trip. Figs. 8(a) - (d) show simplified schematic diagrams of the vehicle of the invention in its principal modes of operation, showing the flow of energy, in the form of electricity or combustible fuel, by dot-dash lines, and the flow of torque by dashed lines. Finally, Fig. 9 provides a high-level flowchart, showing the principal decision points in the algorithm according to which the microprocessor operates the various components of the hybrid vehicle drivetrain according to the invention, and Figs. 9 (a)-(c) show details and modifications thereof.

As noted, the preferred control strategy of the invention is illustrated in several different ways by Figs. 6 - 9. The same specific numerical examples for various significant control variables, data items, and the like are used throughout for clarity. It will be understood that these examples would normally be expressed as ranges; although ranges are not used in the following, to simplify the discussion, it should be understood throughout that these numerical examples are exemplary only, and that the invention is not to be limited to the exact values of the

control variables mentioned herein.

Further, it should be realized that certain of these control variables need not be restricted to specific numbers; in some cases, the decision points may be "fuzzy", i.e., so-called "fuzzy logic" may be employed, so that while the operating scheme retains its overall characteristics, the specific values against which the control variables and data items are tested in implementation of the control strategy according to the invention may vary from time to time. Examples of this practice -- amounting in many circumstances to modifying certain specific values depending on other data items not discussed in detail, or by monitoring the vehicle's actual usage patterns over time -- are given below.

Given these several different explanations of the relationship between the various operating modes of the vehicle of the invention, and specifically these different illustrations of the combinations of conditions in response to which the microprocessor controls mode selection, one of ordinary skill in the art would have no difficulty in implementing the invention.

As noted, during low-speed operation, such as in city traffic, the vehicle is operated as a simple electric car, where all torque is provided to road wheels 34 by traction motor 25 operating on electrical energy supplied from battery bank 22. This is referred to as "mode I" operation (see Fig. 6), and is illustrated in Fig. 8(a). The same paths of energy and torque may also be employed under emergency circumstances, referred to as mode III operation, as discussed below.

While operating at low speeds, e.g., when the vehicle's torque requirements ("road load", or "RL") are less than 30% of the engine's maximum torque output ("MTO"), engine 40 is run only as needed to charge battery bank 22. Starting motor 21 is first used to start engine 40, and is then operated as a generator by appropriate operation of inverter/charger 23, so that charging current flows to battery bank 22. Accordingly, clutch 51 is disengaged, so that the road speed of the vehicle is independent of

the speed of engine 40; engine 40 can thus be operated at relatively high output torque level, for fuel efficiency. This "mode II" operation is illustrated in Fig. 8(b); as indicated, clutch 51 is disengaged, so that engine operation to charge battery bank 22 through starting motor 21, and propulsion of the vehicle by traction motor 25, are completely independent of one another.

As in the '970 patent, engine 40 is sized so that its maximum torque is sufficient to drive the vehicle in a range of desired cruising speeds; this requirement ensures that the engine is operated at high efficiency during normal highway cruising. Therefore, when a sensed increase in the road load (e.g., by a continued operator request for more power) indicates that the preferred operating mode is changing from low-speed to highway cruising operation, the microprocessor controls starting motor 21 by way of inverter/charger 23 to start engine 40. When engine 40 is essentially up to speed, clutch 51 is engaged, so that engine 40 drives road wheels 34 through the shafts of motors 21 and 25. When the operator releases pressure on the accelerator pedal, indicating that a desired cruising speed has been reached, traction motor 25 is accordingly depowered. The highway cruising mode is referred to as "mode IV" operation, and the flow of energy and torque are as illustrated in Fig. 8(c).

If extra torque is needed during highway cruising, e.g., for acceleration or hill-climbing, either or both of motors 21 and 25 can be powered. This "mode V" operation is illustrated in Fig. 8(d); energy flows from tank 38 to engine 40, and from battery bank 22 to traction motor 25, and possibly also to starting motor 21; torque flows from either or both motors and engine to wheels 34.

The flow of energy during battery charging is not illustrated per se in Fig. 8, but will be understood by those of skill in the art, and is further described below. For example, when the engine's instantaneous output torque exceeds the road load, the starter motor 21 is operated as a charger, supplying recharging current to the battery bank. Similarly, when the road load is

trending downwardly or is negative, either the traction motor or the starter motor, or both, can be operated as a regenerative battery charger, supplying recharging current to the battery bank; braking can be accomplished similarly in response to an appropriate operator command.

Fig. 6, as indicated above, is a diagram illustrating differing modes of operation of the hybrid vehicle powertrain of the invention; the modes of operation, indicated by numerals I - V, are plotted on a three dimensional chart, illustrating that the mode of vehicle operation as controlled by microprocessor 48 is a function of the state of charge of the battery bank, the instantaneous road load, and time. Fig. 7, discussed below, further illustrates the inventive mode of vehicle operation.

Fig. 6 shows on one axis the state of battery charge extending from 70% at the origin outwardly to a minimum value shown of 30%. Normally the batteries are maintained at least 30% of full charge. Preferably, the battery bank is not charged to more than 70% of its theoretical full capacity; if a number of series-connected batteries were all charged to 100% of their nominal full charge, some would likely be overcharged due to manufacturing variation, local temperature variation and the like, which would significantly shorten their service life. Moreover, frequently recharging any individual battery to 100% of its theoretical capacity is deleterious to battery life as well.

The road load is shown in Fig. 6 on a second axis as varying from 0 at the origin to 200% of the engine's maximum torque output. (Negative road load, occurring during descents or under braking, is not shown in Fig. 6 due to the difficulty of illustration. This circumstance is discussed in connection with Fig. 7, below.) Time is shown on the third axis extending from an arbitrary point at the origin; that is, Fig. 6 shows the mode of the vehicle's operation over the next short period of time (on the order of 30 - 60 seconds) from a present instant at the origin. Stated differently, according to one aspect of the invention, the microprocessor 48

controls the vehicle's mode of operation at any given time in dependence on "recent history," as well as on the instantaneous road load and battery charge state.

5 More specifically, Fig. 6 shows that during city driving (mode I), defined in this example as driving where the vehicle's instantaneous torque requirements, or "road load", is up to 30% of the engine's maximum torque, the vehicle is operated as a "straight electric" car, the clutch being disengaged and energy from the battery bank 22 being used to power traction motor 25 to propel the  
10 vehicle, as long as the battery remains charged to between 50 and 70% of its full charge. If the charge falls to below a given value, which may vary over time as indicated by the curved line defining the extent of mode II, mode II is entered as indicated, the engine is started, and the starter motor 21 is operated as a  
15 generator to charge the battery to substantially full charge. As indicated in mode III, operation of the vehicle as an electric car may also be permitted when the battery falls to below 40% of full charge, for example, if there is a fault in the engine or charging system, but only on an emergency basis; such deep discharge is  
20 harmful to battery life.

During highway cruising, region IV, where the road load is between about 30% and 100% of the engine's maximum torque output, the engine alone is used to propel the vehicle. Accordingly, when the microprocessor detects that transition between regions I and IV  
25 is required (e.g., the microprocessor can effectively determine the road load by monitoring the response of the vehicle to the operator's command for more power), it causes the starting motor 21 to spin the engine 40 to relatively high speed; when a desired starting speed, typically 300 rpm, is reached, the electronic  
30 engine management unit 55 and electronic fuel injection unit 56 are controlled to fire the spark plugs and supply fuel, respectively, starting the engine. Thus starting the engine at relatively high rpm allows a near-stoichiometric fuel/air mixture to be used, as compared to the much richer mixtures normally used for starting.

Emissions of unburned hydrocarbons are thus substantially reduced, and fuel economy improved.

When the speed of the engine output shaft substantially matches that of traction motor 25, clutch 51 is engaged; the power produced by motor 25 is reduced as that produced by engine 40 is increased, so that the transition between modes I and IV is smooth and essentially undetected by the operator. When the operator reduces pressure on the accelerator pedal 69, indicating that the desired cruising speed has been reached, power to motor 25 is reduced to zero.

If the operator then calls for additional power, e.g. for acceleration or passing, region V is entered; that is, when the microprocessor detects that the road load exceeds 100% of the engine's maximum torque output, it controls inverter/charger 27 so that energy flows from battery bank 22 to traction motor 25, providing torque propelling the vehicle in addition to that provided by engine 40. Starting motor 21 can similarly be controlled to provide propulsive torque.

As indicated above, during highway cruising, where the torque required to propel the vehicle varies as indicated by the operator's commands, the control system operates the engine at correspondingly varying torque output levels. The range of permissible engine torque output levels is constrained to the range in which the engine provides good fuel efficiency. Where the vehicle's instantaneous torque requirement exceeds the engine's maximum efficient torque output, e.g., during passing or hill-climbing, one or both of the electric motors are energized to provide additional torque; where the vehicle's torque requirements are less than the torque then being produced by the engine, e.g., during coasting, on downhills or during braking, the excess engine torque is used to charge the batteries. Regenerative charging may occur simultaneously, as torque from the engine and recovery of the vehicle's kinetic energy both drive one or both motors operated in generator mode. The rate of change of torque output by the engine

may be controlled to reduce emissions, and in accordance with the state of charge of the battery bank. Fig. 7 illustrates these relationships.

As mentioned above, Fig. 7, comprising Figs. 7(a) - (c), and extending over two sheets, is a timing diagram showing the relationship between road load, engine torque output, the state of charge of the battery bank, and operation of the engine as these vary over time, during low-speed city driving, highway cruising, and extended high-load driving, thus further illustrating the control strategy employed according to the invention.

Fig. 7(a) shows the vehicle's instantaneous torque requirement, that is, the "road load", by a solid line, and the engine's instantaneous output torque by a dashed line, as these vary over time. (The engine's instantaneous output torque is repeated in Fig. 7(c), for clarity, and in order to clearly show certain additional aspects of the inventive control strategy.) The road load is expressed as a function of the engine's maximum torque output. Where the road load exceeds the engine's instantaneous output torque, the cross-hatched areas between these two lines represent torque provided by the traction and or starting motor(s); where the road load is less than the engine's instantaneous output torque, the cross-hatched areas represent charging of the batteries.

It will be appreciated that positive vehicle torque demands correspond to steady-state cruising, acceleration, hill-climbing, or the like, while negative vehicle torque requirements correspond to deceleration or descent. The engine's output torque is constrained to the range of efficient operation; as illustrated in Fig. 7 (a) and (c), this range is controlled to be between 30% and 100% of the engine's maximum torque output ("MTO"). As mentioned above, it will be appreciated that the 30% figure, as well as similar figures mentioned herein, may vary without departure from the scope of the invention.

In the example of vehicle operation shown in Fig. 7, initially

the vehicle is operated only at road loads below 30% of MTO, that is, in traffic, as indicated at A. Accordingly, all the torque required is provided by the traction motor 25, and the state of charge of the battery bank 22 ("BSC"), as illustrated by Fig. 7(b), corresponds directly to the road load; when the road load is negative, BSC increases as the battery bank is charged by regenerative braking. (Changes in BSC are significantly exaggerated in order to clearly explain the events shown.)

At point B, the road load exceeds 30% of MTO for the first time on this particular trip. When this is detected by microprocessor 48, starting motor 21 spins the engine 40 at relatively high speed, and the catalytic converter 64 is preheated, causing a short drain on BSC, as shown at C. When the engine reaches the desired starting speed, e.g. 300 RPM, and the catalyst reaches a minimum effective operating temperature, e.g. at least about 350° C, the engine is started by supply of fuel and firing of its spark plugs, and the clutch is then engaged. As the engine is already rotating at relatively high speed, and will have been warmed by compression of air in its cylinders during the starting process, it begins to produce useful torque almost immediately, as indicated at D.

Thereafter, when the vehicle's torque requirement exceeds the instantaneous engine output torque, as at points E - G and P, one or both of the traction and starting motors 25 and 21 are powered to provide additional torque to the road wheels, that is, the vehicle is operated in mode V. While the road load RL remains within the engine's efficient operating range, e.g., while  $30\% \text{ MTO} > \text{RL} > 100\% \text{ of MTO}$ , the vehicle is operated in mode IV. During mode IV operation, if the engine's instantaneous torque output exceeds the vehicle's torque requirement, but the battery is relatively fully charged, as at point H, the engine's torque output is reduced to match the road load; when MTO exceeds the road load, and BSC falls below a predetermined level (see Fig. 7(b)), as at I and J, the excess torque available from engine 40 is used to charge



the batteries, as indicated at K and L (Fig. 7(c)). When the vehicle's torque requirement is less than the minimum permissible engine torque output, as at M, the engine is again used to charge the batteries, and regenerative braking is also performed, further charging the batteries. If the batteries become substantially fully charged, e.g., during a long descent, as at N, the engine may be shut off entirely, as seen at Q in Fig. 7(c).

More particularly, during deceleration or "coast-down", the engine may be "motored", that is, driven by torque from the wheels, with the clutch engaged, but with at least the fuel supply shut off. In addition to using no fuel, this has the advantage that when the operator next requires torque, e.g., when reaching the point at the bottom of a hill, the engine is rotating and can be immediately restarted by supply of fuel. The exhaust valves might be opened during the motoring of the engine to reduce pumping losses.

The rate of change of the engine's torque output is limited, e.g., to 2% or less per revolution, as indicated by noting that the dashed line in Fig. 7(a), indicating the instantaneous engine output torque, lags the solid line indicating the vehicle's instantaneous torque requirement. Thus limiting the rate of change of engine output torque is preferred to limit undesirable emissions and improve fuel economy; that is, as the stoichiometric fuel/air ratio varies somewhat as the load changes, simply opening the throttle and causing additional fuel to be injected (as is typically practiced) upon the operator's depressing the accelerator pedal would result in non-stoichiometric, inefficient combustion. According to this aspect of the invention, the rate of change of engine torque is limited; this provides sufficient time for the essentially conventional electronic engine management and electronic fuel injection systems, which comprise a "lambda sensor" 47 (Fig. 3) for monitoring the oxygen content of the exhaust gas stream as an indication of stoichiometric combustion, to respond as the load changes, preserving stoichiometric combustion and reducing

emission of unburned fuel.

The maximum permissible rate of change of engine output torque also may be varied in accordance with the state of charge of the batteries; more specifically, if the batteries are relatively discharged, it may be preferable to allow the engine's output torque to ramp-up more quickly than otherwise, in order to limit the amount of electrical power drawn from the batteries in response to an acceleration command. More generally, it is preferred to operate the engine so as to limit the amount of power drawn from the batteries, as there are unavoidable losses attendant on conversion of energy stored in the batteries to motor output torque, and during the corresponding recharging period.

As mentioned above, Fig. 9 is a high-level flowchart of the principal decision points in the control program used to control the mode of vehicle operation. Broadly speaking, the microprocessor tests sensed and calculated values for system variables, such as the vehicle's instantaneous torque requirement, i.e., the "road load" RL, the engine's instantaneous torque output ITO, both being expressed as a percentage of the engine's maximum torque output MTO, and the state of charge of the battery bank BSC, expressed as a percentage of its full charge, against setpoints, and uses the results of the comparisons to control the mode of vehicle operation.

As noted above, certain control decisions involved in the inventive control strategy illustrated in Fig. 9, and described therein as being determined in response to precise criteria (in order to clearly present the main features of the inventive operating strategy), may instead be usefully somewhat "fuzzy"; in the present application, this term is intended to indicate that the value of a setpoint (for example) may vary somewhat in response to recent history, or in response to monitored variables not discussed above. As mentioned above, it is also to be understood that the values given above for various numerical quantities may vary somewhat without departing from the invention. Specific

alternatives are provided below for steps set forth in Fig. 9 that implement certain of these alternatives.

For example, in the example of the inventive control strategy discussed above, it is repeatedly stated that the transition from low-speed operation to highway cruising occurs when road load is equal to 30% of MTO. This setpoint, referred to in the appended claims as "SP", and sometimes hereinafter as the transition point (i.e., between operation in modes I and IV) is obviously arbitrary and can vary substantially, e.g., between 30 - 50% of MTO, within the scope of the invention.

It is also within the scope of the invention for the microprocessor to monitor the vehicle's operation over a period of days or weeks and reset this important setpoint in response to a repetitive driving pattern. For example, suppose the operator drives the same route from a congested suburban development to a workplace about the same time every morning; typically the road load might remain under 20% of MTO for the first few minutes of each day, then vary between 0 and 50% of MTO for another few minutes as the operator passes through a few traffic lights, and then suddenly increase to 150% of MTO as the operator accelerates onto a highway. It is within the skill of the art to program a microprocessor to record and analyze such daily patterns, and to adapt the control strategy accordingly. For example, in response to recognition of a regular pattern as above, the transition point might be adjusted to 60% of MTO; this would prevent repetitive engine starts as the road load exceeded 30% of MTO for a few hundred yards at a time, as might often occur in suburban traffic. Similarly, the engine starting routine might be initiated after the same total distance had been covered each day.

It is also within the scope of the invention to make the setpoint SP to which the road load is compared to control the transition from mode I to mode IV somewhat "fuzzy", so that SP may vary from one comparison of road load to MTO to the next depending on other variables. For example, as discussed above, if during

low-speed operation the operator depresses the accelerator pedal rapidly, this can be treated as an indication that full power will shortly be required, and the engine-starting operation begun before the road load reaches any particular setpoint SP.

5 The value of the transition point may also vary in dependence on the mode of operation in effect when the road load equals a given setpoint SP. For example, suppose the setpoint at which the mode of operation is controlled to change from the low-speed mode to the highway cruising mode is normally set to 30% of MTO, as in 0 the examples discussed above. If traffic conditions were such that the road load fluctuated around this value, and engine operation were controlled solely in response to road load, the engine would be repeatedly started and shut off as the road load exceeded 30% of MTO for a few hundred yards at a time, and then fell back below 30% 15 of MTO, as might often occur in suburban traffic. Repeated restarts might also occur if the road load averaged over 30% of MTO but occasionally dropped below this value, as might occur in moderate-speed, flat-road cruising.

20 By monitoring the road load over time, and comparing it to different setpoints accordingly, much of this undesirable repetitive sequence of engine starting and shut-off can be eliminated. It might be preferable to commence mode IV operation upon the occurrence of differing conditions; for example, mode IV might be entered from mode I only after the road load exceeded a 25 first, lower setpoint SP for an extended period of time, so that the engine would be run for extended low-speed cruising, but to start the engine immediately if the road load exceeded a higher setpoint SP2, e.g. 50% of MTO, as during acceleration to highway speed. Similarly, the engine might preferably be shut down only if 30 the road load was less than a minimum setpoint for mode IV operation for an extended period of time. Thus providing "hysteresis" in the mode-switching determination would limit repetitive engine starts in certain types of driving. These limits could be further adjusted as the driving pattern became clear,

i.e., as discerned by the microprocessor.

In a further refinement, the setpoint at which the engine is shut off as the road load dropped below the usual minimum value for mode IV operation could vary dependent on BSC; if the batteries were substantially fully charged, the engine might be shut off as road load dropped below 30% of MTO, but if their charge was lower the engine might be controlled to continue to run, even at a stop, i.e., zero road load, to charge the batteries. Of course, the clutch would still have to be disengaged at when the road load fell below 20 - 30% of MTO, in order that the engine could run at an efficient speed for production of torque.

Fig. 9 thus shows the main decision points of the control program run by the microprocessor, with the transition point between mode I, low-speed operation, and mode IV highway cruising, set at a road load equal to 30% of MTO. Examples are then given for some of the various options discussed above, by substituting various of the decision points with alternatives indicated below. Other optional points not specifically shown but discussed herein are within the scope of the invention.

The control program is entered at step 100, where the microprocessor determines whether the road load RL is less than 30% of MTO. If the answer is yes ("Y"), the clutch is disengaged if necessary as indicated at steps 103 and 105. The state of charge of the battery bank BSC is then tested at step 110; if BSC is between 50 and 70% of full charge, the vehicle can operate for some time as a straight electric vehicle, and mode I is accordingly entered, as indicated at 115. A "mode I" loop is then established, including steps 100, 103, and 110; as long as all conditions tested in these steps remain stable, the vehicle continues to be operated in mode I.

However, if at step 110 it was determined that BSC was less than 50% of its maximum value ("N"), the engine should be run, if possible, to charge the battery bank, up to, for example, 75% of its maximum charge, as tested at step 120. If the engine is

5 already running, as tested at step 125, the battery is charged as indicated at 130, and a stable "mode II" loop, as noted at 135, is established including steps 100, 103, 110, 120, 125, and 130. (Normal operation of step 110 would be bypassed or disabled in this mode to prevent battery charging from being stopped when BSC reaches 70%). If the engine is not running, an engine starting subroutine (shown separately, by Fig. 9(a), is entered, as indicated at step 140.

0 In the engine starting subroutine, beginning with the 'enter' block 141, the clutch is disengaged if necessary at steps 142 - 143, and the catalyst temperature is tested at 145, to determine whether it is at least about 350° C; the catalyst is heated as necessary, as indicated at 150. When the catalyst is heated suitably, the engine is then spun by the starter motor until a desired starting speed is reached, as indicated by the loop including blocks 155 and 160. When the engine reaches its desired starting speed, it is started at step 165, by supply of fuel and firing of its spark plugs, concluding the engine starting subroutine as indicated by 'return' block 170. If the engine starting subroutine was entered from the mode II loop, as above, the battery bank may then be charged as indicated at 130.

20 If in performance of step 120 it appeared that BSC was less than 40%, which would only occur upon failure of the engine or charging system, step 175 may be performed; thus, if  $30\% < BSC < 40\%$ , the vehicle may be operated in mode III as an electric car, to provide emergency operation. However, this should be strictly limited to avoid deep discharge of the battery bank, tending to shorten its useful life. As indicated at 177, the vehicle is completely disabled if BSC falls below 30%.

30 If RL is determined to exceed 30% of MTO in step 100, the program goes to step 180, where the term  $30\% > RL > 100\%$  is evaluated; that is, the microprocessor determines whether the road load is appropriate for highway cruising in mode IV. If so, and if the engine is running, as tested at step 190, a stable loop

including steps 180 and 190 is established; the system remains in mode IV, as indicated at 185, until the state of one of these tests changes.

5 If in step 190 it is determined that the engine is not running, the engine start subroutine, starting with step 140 as discussed above, is entered as indicated at 195; upon return, at 200, the clutch is engaged at 210, and the loop including steps 180 and 190 is entered.

10 As noted, in step 180 it is determined whether RL is between 30 and 100% of MTO; if not, it is determined in step 220 whether RL is greater than 100% of MTO. If so, mode V is entered, and the traction motor (and optionally the starting motor) is powered to provide additional torque propelling the vehicle, as indicated at 230. A loop including steps 220 and 230 is thus established, so  
15 that mode V remains stable until the state of the test performed in step 220 changes.

20 When in performance of step 220, it appears that RL is now less than 100% of MTO, it is then determined in step 215 whether RL is less than 30% of MTO. If so, the engine is shut off, as indicated at 240, and the program returns to step 100; if not, the program is returned to step 180.

25 It will be appreciated that according to the Fig. 9 flowchart, it is possible for the system to proceed directly from mode I to mode V, that is, from step 100 to step 220, if the road load rapidly increases from less than 30% of MTO to more than 100% of MTO. Permitting the operator to thus operate the system is an important safety feature, for example when fast acceleration from a stop is required to merge into highway traffic. In these  
30 circumstances the engine would not be running during initial operation in mode V, necessitating a significant drain on the battery bank and overdriving the traction motor. Accordingly, steps equivalent to steps 190, 195, and 210 (including the engine starting subroutine) are to be understood to follow step 220 and precede step 230. That is, in the event mode IV was effectively

omitted in passing directly from mode I to mode V, the engine is started and the clutch engaged as soon as possible; these duplicate steps are not shown, for clarity.

5 In the above discussion of Fig. 9, it was assumed that the transition point between low-speed and highway operation is set so that the transition occurs when the road load is equal to 30% of MTO under all circumstances. However, as discussed above, it may be desirable to operate the system so that the vehicle goes from the low-speed mode I to the highway-cruising mode IV at a higher road load, e.g., 50% of MTO, than the road load at which the low-speed mode is reentered, e.g., when road load in mode IV falls to below 20%. This "hysteresis" of the mode switching point -- for example, allowing the vehicle to accelerate in mode I up to road loads of up to 50% of MTO, but not shutting the engine off, ending mode IV operation, until road load falls below 20% of MTO -- avoids excessive mode-switching during periods of fluctuating road load.

15 For example, in typical suburban traffic, one might commonly accelerate past 30% of MTO, to what might otherwise be a normal cruising speed, but stop again shortly thereafter; it would be inefficient to thus repetitively stop and restart the engine as the load fluctuates around 30%. Hysteresis might similarly be useful in avoiding needless mode switching in moderate-speed, flat road cruising in mode IV, when the road load might well occasionally drop below 30%; again, it would be inefficient to repeatedly shut off and restart the engine.

20 Thus providing differing mode switching points depending on the direction of the change in road load can be accomplished readily by monitoring the road load RL as a function of time, and taking appropriate control action. For example, if the system is maintained in mode I until RL exceeds the "normal" 30% of MTO mode switching point for a period of, for example, 30 seconds, and without exceeding 50% of MTO, the excessive mode switching otherwise likely to be encountered in suburban traffic can be



largely avoided. Fig. 9(b) shows a step 100' replacing step 100 in Fig. 9 and implementing this "low-speed hysteresis". As indicated, the system remains in the low-speed mode I as long as RL is less than 30% of MTO, or unless RL exceeds 30% of MTO for more than 30 seconds, or exceeds 50% of MTO; if either of the latter conditions occurs, the program goes to step 180, initiating mode IV operation.

Similarly, hysteresis in mode IV cruising, in order to implement excessive mode shifting that might otherwise occur if the road load fluctuates around a fixed mode switching point, can be implemented by simply providing that the system remains in mode IV as long as RL remains between 30 and 100% of MTO, unless RL is less than RL for more than 30 seconds, or exceeds 100% of MTO. This can be implemented as shown in Fig. 9(c); a revised step 215' replaces step 215 of Fig. 9, and provides that, if the system is in mode IV, unless RL is less than 30% of MTO for more than 30 seconds, step 180 is re-entered, thus preserving the "mode IV loop"; when RL is less than 30% of MTO for more than 30 seconds, the engine is shut down, at step 240, control is passed to step 100, and mode I re-entered.

Numerous further modifications to the detailed control strategy of the invention as illustrated in Figs. 6 - 9 will occur to those of skill in the art, and are within the scope of the invention. For example, it may be desirable to vary the operation of the system insofar as responsive to BSC in accordance with monitored variables indicative of battery temperature, ambient temperature, and the like; e.g., on a hot day it may be advisable to avoid charging the battery bank to more than 60% of full charge, as this may cause overheating. Further, as noted above the transition points between modes I, IV, and V in particular may vary in accordance with the operator's commands, so as to provide maximum vehicle responsiveness for safety and ease of consumer acceptance, and over periods of days or weeks, as the microprocessor builds up a detailed historical record of the vehicle's usage pattern, from which an optimized control strategy

may be derived.

It may also be possible to provide the microprocessor with useful control information from the operator, without requiring the operator to understand the workings of the system in detail. For example, operators are now well-accustomed to set a "cruise control" when a desired cruising speed is reached; thereafter, existing engine management systems control the instantaneous engine torque output with respect to variation in the road load to maintain vehicle speed substantially constant. It would be a simple matter for the microprocessor to accept a desired cruising speed thus input by the operator, as indicated in Fig. 4. The operator would then be relieved of continuous throttle control, and the microprocessor would similarly control the instantaneous engine torque output with respect to variation in the road load to maintain vehicle speed substantially constant, both as conventional; however, according to the invention, the microprocessor would also reset the transition point so that the system would remain in cruising mode IV until the operator had indicated to the contrary, i.e., by exiting cruise mode.

As discussed above, according to a further embodiment of the invention, additional flexibility is provided to the hybrid vehicle as described above by providing a turbocharger 100, also controlled by the microprocessor 48, so as to be operated when useful in further improving vehicle efficiency and drivability and not at other times. Providing the "turbocharger-on-demand" allows the engine to function efficiently in different torque output ranges, as needed. Essentially, the turbocharger 100 is employed only when the vehicle's torque requirements, the "road load" as above, exceeds the engine's normally-aspirated maximum torque capacity for a relatively extended period T of time, for example, during extended high-speed driving, towing a trailer, or driving up a long hill. Where the road load exceeds the engine's maximum torque for a relatively short period less than T, the traction motor (and possibly also the starting motor) are used to provide additional

torque, as in the '970 patent and above. According to a further aspect of the invention, the period T is controlled in response to the state of charge of the battery bank; when the battery bank is relatively depleted, the turbocharger is activated sooner than otherwise, so as to preserve the battery bank.

As is well known to those of skill in the art, a turbocharger 100 (see Fig. 11) typically comprises two turbine wheels 102 and 104 on a common shaft 106, referred to herein as the exhaust-side and air-side wheels respectively. The flow of exhaust gas from engine 40 causes exhaust-side wheel 102 to spin; air-side wheel 104 is driven by shaft 106, drawing air into the body of turbocharger 100 through air filter 110. Waste heat in the exhaust stream is thus effectively recovered by compressing the intake air, which is then ducted to the intake manifold 122 of engine 40. Additional fuel can be burned in the additional air thus provided, so that additional torque is produced. The compressed air may be cooled adiabatically by heat exchange with ambient air in intercooler 117 if desired, further improving thermal efficiency of engine 40.

In typical turbocharger operation, a "wastegate" 114 is provided to limit the exhaust pressure incident on exhaust-side wheel 102, thus limiting the speed of air-side wheel 104 and regulating the "boost" provided by the turbocharger. The waste gate may be spring-loaded to open at a fixed boost pressure (as typically provided to regulate the output of turbocharged racing engines) or may be controlled in a feedback loop using the pressure in the engine intake manifold as the control variable. See Automotive Handbook, 2nd Ed., Robert Bosch GmbH (1986), p. 356. Further, in conventional practice, the turbocharger is used at all times, and the engine's design is optimized accordingly. For example, turbocharged gasoline engines typically have compression ratios of 7 or 8 to 1, as compared to 9 - 11 to 1 for normally-aspirated engines. Neither practice is employed according to the present invention; the turbocharger is controlled by the microprocessor to operate only when needed, and the engine's

compression ratio, and other design parameters, are selected based on design criteria relevant when operated in the normally-aspirated mode.

5 According to the present invention, the waste gate 114 is controlled by the microprocessor 48; except under circumstances when the extra power provided by turbocharging is needed, the waste gate 114 is open (as shown in Fig. 1), so that the engine exhaust essentially bypasses the turbocharger 100. A valve 120, also controlled by microprocessor 48, may also be provided in the duct  
10 connecting the air side of the turbocharger 100 and the intake manifold 122 of the engine, so that the engine 40 draws air through the turbocharger only when in use; a second air filter 124 is then also provided.

15 Commonly, turbocharging for automotive use is employed in order that relatively small-displacement engines will produce high horsepower at the upper end of their operating range; the other design parameters of such engines (e.g., camshaft profiles) are chosen similarly. Engines thus optimized for high-rpm horsepower produce reduced low-speed torque, that is, are "peaky" compared to  
20 normally-aspirated engines. A variable-ratio transmission is essential to obtain reasonable acceleration from low speeds. Stated differently, turbocharging as usually implemented for automotive use provides relatively high torque at the upper end of the engine's speed range, but relatively poor torque at lower speeds;  
25 such an engine would be unsuitable in practice of the present invention. Moreover, turbocharged engines typically suffer "turbo lag", that is, slow response to sudden increase in torque required. As discussed further below, this particular problem is overcome by use of the turbocharger in a hybrid vehicle according to the  
30 invention.

Those of skill in the art will recognize that turbocharged engines are also used in heavy-load road vehicle applications, such as trucks and the like, but these vehicles demand transmissions having 12, 16, or more ratios, so that the engine's narrow power

5 peak can be matched to the load, and exhibit extremely poor acceleration, as well as excessive gear-changing and cost, all of which would be unacceptable to the ordinary motorist. Thus, normally-turbocharged engines, of both the low-speed truck type, or the high-speed automotive type, are not satisfactory in implementation of the present invention.

10 As also noted above, as conventionally employed, a turbocharger is used at all times. By comparison, according to the present invention, the turbocharger is controlled by the microprocessor 48 to be used only under specified driving conditions, allowing the engine to be operated efficiently in other modes.

15 Fig. 12, as indicated above, is a diagram comparable to Fig. 6. The differing modes of operation of the hybrid vehicle powertrain of the invention shown thereon are identical to those of the Figs. 3 and 4 vehicle illustrated in Fig. 6, with the addition of turbocharged mode VI. Similarly, Fig. 13 is similar to Fig. 7, but illustrates the operation of a vehicle including a "turbocharger-on-demand" according to this aspect of the invention.

20 As shown in Fig. 12, according to this aspect of the present invention, a further region VI is provided, wherein the turbocharger 100 is activated by the microprocessor 48 when it detects that the road load has exceeded the engine's maximum output for more than a period of time T. Typically these events will occur when the vehicle is towing a trailer or is otherwise heavily laden, is climbing a long hill, or is operated at high speed for a long period of time.

25 More specifically, when the road load only exceeds the engine's maximum power for a short time, less than T, as during acceleration onto a highway or during passing, the traction motor is employed to provide the additional torque required, as described above. When the road load exceeds the engine's maximum power for a time greater than T, the turbocharger is energized by closing waste gate 114, and operating valve 120, if provided, to open the

duct between the air-side of turbocharger 100 and the intake manifold 122 of engine 40. As the turbocharger "spools up" to its operating speed range, the maximum torque produced by engine 40 increases, and the torque produced by traction motor 25 is gradually reduced. This sequence of events is discussed further below in connection with Fig. 13.

Fig. 12 also shows, by the angle of the line separating regions V and VI with respect to the  $t = 0$  plane, that T can vary with the state of charge of the battery bank 22; when the battery bank is fully charged, T is longer -- that is, energy from the battery bank is used to satisfy road load in excess of the engine's maximum torque output for a longer period -- than when the battery bank is relatively less fully charged. The turbocharger can also be operated to provide additional engine power when full acceleration is needed, e.g., upon detection of the operator's aggressively pressing the accelerator pedal down completely.

As mentioned above, Fig. 13, comprising Figs. 13(a) - (c), and extending over two sheets, is a timing diagram showing the relationship between road load, engine torque output, the state of charge of the battery bank, and operation of the engine in electric car, normally-aspirated and turbocharged modes as these vary over time, during low-speed city driving, highway cruising, and extended high-load driving, thus further illustrating the control strategy employed according to the invention. Fig. 13 is essentially identical to Fig. 7, with the addition of illustration of the operation of turbocharger 100 when the road load exceeds 100% of MTO for more than a period of time T.

Thus, as shown in Fig. 13(a) at  $t_1$ ,  $t_2$ ,  $t_3$ , and  $t_4$ , the microprocessor monitors the length of time t during which road load exceeds 100% of MTO, and compares t continually to a value T preferably varied in accordance with BSC; this is shown by the relative lengths of the arrows marked T on Fig. 13(b). While  $t < T$ , as at E, F, and G in Fig. 13(a), the excess torque required by the road load is provided by either or both of the traction and

starting motors, drawing power from the battery bank. Note that the motors together are rated to be capable of continuously providing torque up to at least 100% of MTO, in accordance with the '970 patent; this allows the motors to provide adequate torque for good vehicle performance without a variable-ratio transmission. The motors may also be overdriven to provide more than their rated torque, well over 100% of MTO, for short periods of time,  $t < T$ , as at F; as noted, according to an important aspect of the invention, where torque in excess of MTO is needed for a longer period of time,  $t > T$ , the turbocharger is activated.

Thus, when  $t_4 \geq T$ , as at P, the microprocessor activates the turbocharger essentially as discussed above, that is, by closing waste gate 114 and valve 120 (if provided). As the turbocharger "spools up", which may take some seconds, and the boost it provides increases, as indicated at Q, the torque provided by the traction motor (and possibly also by the starting motor) is decreased accordingly, as indicated at R. The operator need not be aware of or take any action to initiate the turbocharger's activation; this is controlled by the microprocessor in response to monitoring the road load over time and the state of charge of the battery bank.

As discussed in connection with both Figs. 12 and 13, T is preferably varied in accordance with BSC, so that the turbocharger is activated relatively sooner when BSC is relatively low; this limits the amount of energy drained from the battery during operation of the engine and the traction motor (or both motors) when the road load exceeds 100% of MTO, so that BSC does not fall to an undesirably low value.

Those of skill in the art will recognize that provision of a microprocessor-controlled turbocharger in a hybrid vehicle according to the invention permits operation in an additional mode, providing increased flexibility in the operational scheme provided; essentially the turbocharger provides a larger engine only when needed, at no cost in efficiency at other times. This is particularly significant in meeting the goals of the hybrid vehicle

of the invention. More specifically, in addition to the operational advantages noted, provision of a "turbocharger-on-demand" in the hybrid vehicle according to the invention allows the engine to be smaller than otherwise, that is, to provide adequate highway performance in a vehicle of a given weight. As the starting motor/generator must be sized such that when it is operated to charge the batteries (e.g., in extended city driving) it loads the engine adequately that the engine is operated efficiently, employment of a smaller engine allows use of a smaller generator motor. For similar reasons, provision of a smaller engine allows it to be used to efficiently propel the vehicle in highway driving commencing at lower average speeds, resulting in turn in better fuel economy. By providing the "turbocharger-on-demand" according to the invention, all these advantages can be realized without sacrifice in the ultimate performance of the vehicle.

As noted above, one convenient implementation of the "turbocharger-on-demand" according to the invention is to operate the wastegate by a solenoid or the like controlled by the microprocessor, that is, to employ the wastegate as a bypass valve except when turbocharged operations are desired. A separate bypass valve might also or alternatively be provided. The wastegate is still preferably implemented as a spring-loaded relief valve, as illustrated in Fig. 11, and as generally conventional, to limit the "boost" provided. It is also within the invention to operate the waste gate to take intermediate positions, that is, between fully-open and closed positions, so as to limit the torque to limit wheelspin as detected, and to keep the turbocharger wheels spinning at an intermediate speed, to reduce the time necessary to "spool up" to full speed. It is also within the invention to adjust the wastegate responsive to an atmospheric-pressure signal provided by a suitable sensor 107 (Fig. 11) to ensure that adequate boost is provided at higher altitudes to ensure vehicle performance.

It will also be appreciated that a supercharger, that is, a



positive-displacement air pump driven by the engine, could be used to implement the differing modes of vehicle operation illustrated in Figs. 12 and 13; for example, the supercharger's operation could be controlled by the microprocessor by driving it through an electrically-controlled clutch, and this is accordingly within the invention. However, this would be less efficient than turbocharger operation, as turbocharging effectively recovers some of the waste heat in the engine exhaust by compressing the air reaching the inlet manifold, while supercharging consumes engine torque. Turbocharging, as discussed in detail, is accordingly preferred.

It will therefore be appreciated that by providing the internal-combustion engine of a hybrid vehicle with a turbocharger controlled by the vehicle's controller to operate only during extended periods of high torque requirements, a number of important advantages are realized, both as compared to a conventional system wherein the turbocharger is continually activated, or as compared to a large engine having the same maximum torque as the smaller turbocharged engine. As to the latter, as explained above all internal combustion engines are extremely inefficient, except when operated at near peak torque output; the larger the engine, the less frequently this will occur. As to the former, employing a conventionally-turbocharged engine, having the typical "peaky" torque curve, would not allow the engine to be used to propel the vehicle during highway driving without a variable-speed transmission. Instead, by providing a "turbocharger-on-demand", that is, which is only employed when it is actually needed, the vehicle of the invention can employ a small engine optimized for its main function of propelling the vehicle efficiently during highway cruising, and which is operable as a much larger engine when needed.

Other advantages provided by the invention include the fact that as the wastegate is normally open, the exhaust temperature will stay high, optimizing catalytic converter performance; as conventionally implemented, cooling of the exhaust gases as their

energy is removed in spinning the turbocharger rotor can prevent good catalytic converter performance, especially at low speeds. Further, because the traction motor provides additional torque when needed, the "turbo lag" experienced in conventional turbocharged vehicles as the turbocharger "spools up" when the operator calls for more power is eliminated.

When constructed and operated according to the invention, that is, as a hybrid vehicle having an internal-combustion engine with a turbocharger controlled by the vehicle's controller to operate only during extended periods of high torque requirements, even a heavy vehicle having poor aerodynamic characteristics, such as a sport-utility vehicle or van, can offer good acceleration and hill-climbing and towing ability, while still providing extremely good fuel economy and extremely low emissions.

Another aspect of the invention concerns the method of sizing the various components of the system. Examples were given above of component selection for a vehicle not including a turbocharger according to this aspect of the present invention. Using as a further example a 5,500 pound "sport-utility vehicle" ("SUV") required to have reasonable acceleration and passing performance even while towing a 6,000 pound trailer, sizing of the components of the hybrid drive system of the present invention is preferably accomplished as follows:

1. An internal combustion engine is selected which has sufficient torque to drive the SUV without trailer at medium to high speed along a moderate grade. More specifically, a typical specification will require that the engine be sufficiently powerful to proceed up a 6% grade of unlimited extent at 50 mph. An engine of 100 hp at 6,000 maximum RPM is appropriate to meet this requirement for the SUV described above.

2. If a trailer is to be towed, a turbocharger, operated as above, is added. The turbocharger is sized so that when it is operated the engine provides up to 140 hp.

3. The charger motor is sized so as to provide an engine load

equal to approximately 70% of the engine's maximum torque at a suitable engine speed. In this way fuel is used efficiently during battery charging, as discussed above. In the example, the charger motor is preferably an induction motor of 15 - 30 hp capacity, possibly configured as a "faceplate" or "pancake" type, essentially forming the flywheel of the engine. Such a motor can be operated as a generator requiring 20 - 22 hp, which is 70% of the maximum torque produced by the engine specified above when operated at 1200 - 1500 rpm; battery charging can thus be accomplished in a very fuel-efficient manner. This is essentially equivalent to specifying the starter/generator based on its ability to accept at least about 30% of the engine's maximum torque output (MTO, as above); in this way the engine is operated at a fuel-efficient power level during charging.

4. The traction motor is sized to provide adequate torque at zero speed to overcome the maximum grade specified from rest, with the starter motor assisting as needed. In the example the traction motor may be an induction motor of 100 hp, with a maximum speed of 16,000 rpm, and be connected to the drive wheels through a chain drive providing the appropriate reduction ratio. It will be appreciated that in this example the total torque available from the starting and traction motors combined exceeds that provided by the engine, in accordance with an aspect of the invention of the '970 patent.

5. The torque vs. speed profile of the traction motor is selected to allow city driving, in particular, to provide acceleration sufficient to conform to the Federal urban driving fuel mileage test ("FUDS"), without use of torque from the engine.

6. The battery capacity is then selected to provide sufficient cycle life, i.e., so as not to be overstressed by deep discharge over many repetitive driving cycles. In the example, an 800 v, 8.5 KAH battery pack is provided. The battery bank should be sized and arranged so that the maximum current to be absorbed with the starter/generator being driven at 30% of MTO is no more than 50

amperes.

5 7. Finally, the controller is provided with software to  
implement the control scheme described in detail above, that is, to  
use the traction motor as the only source of drive torque at low  
speed, to start the engine when the road load increases beyond a  
10 setpoint, to operate the turbocharger when the road load exceeds  
the engine's maximum torque for more than a prescribed time T,  
which may be varied in accordance with the state of charge of the  
batteries, and otherwise as described above. Essentially, the  
controller is operated so that the engine is only operated in a  
fuel-efficient range, e.g., driving a load at least equal to 30% of  
MTO.

15 Simulations show that vehicles configured as above will  
generally be capable of 80 - 100% improvement in fuel economy with  
respect to conventional vehicles of similar size, weight and  
performance characteristics.

#### Further Improvements according to the Continuation-in-Part

##### Component Specification

20 In addition to the methods of sizing the components of the  
powertrain and ancillary components set forth above, another method  
of doing so is generally as follows. As set forth above, it is  
desirable for a number of reasons to operate the system of the  
25 invention at relatively high voltages, e.g., 800 V or above, in the  
case of larger vehicles; this reduces the current flowing  
throughout the system, which allows use of plug-in rather than  
bolted connectors, allows use of inexpensive automatic disconnects,  
and reduces resistance heating losses.

30 More particularly, suppose that the "average maximum" current  
(e.g., defined as the maximum current flowing for more than, for  
example, thirty seconds; under most circumstances, the average  
current would be much less) is controlled to be 50 A. This allows  
use of inexpensive mass-produced plug-in connectors, and can be

controlled by inexpensive mass-produced power electronic components, as needed to construct the inverter/charger units. These components can be designed to conduct up to approximately 200 A for up to thirty seconds, so that full acceleration can be provided for a time sufficient for the vehicle to reach essentially its maximum speed; according to this aspect of the invention, the peak current can accordingly be set at, for example, 150 A, and the power electronics components then sized based on this value.

More particularly, it appears useful to size the components with respect to one another, in particular, the battery bank with respect to the traction motor(s), so that the peak current is no more than about 150 A, and so that under peak electrical loading (usually under acceleration) a ratio of at least 2.5 : 1 of the battery voltage to the peak current is exceeded.

For example, suppose it is desired to implement the invention with respect to a relatively heavy, e.g., 6000 pound, vehicle having target acceleration capabilities such that a 120 HP electric traction motor, typically drawing 100 kW, will be required. The battery bank for such a vehicle is sized to provide a nominal voltage of 830 V (i.e., when not under load); this will drop to approximately 650 V under load. The battery bank will thus be required to produce 153 A ( $= 100 \text{ kW}/650 \text{ V}$ ) during full acceleration, and the ratio of voltage to peak current is 3.92 ( $= 650 \text{ V}/153 \text{ A}$ ).

In another example, of a much lighter 3000 lb vehicle, a 80 HP, 60 kW motor might be sufficient. To keep the peak current to 115 A, a battery bank of 600 V nominal, 500 V under load would be required. The ratio is then 4.3 ( $= 500\text{V}/115 \text{ A}$ ).

By comparison, insofar as known to the inventors, the Toyota "Prius" hybrid car now being marketed uses a 30 kW motor, and its battery bank provides approximately 230 V under load; the current required is thus approximately 120 A ( $= 30 \text{ kW}/230 \text{ V}$ ) and the ratio between the voltage under load and the peak current is only about 2 ( $= 230\text{V}/120\text{A}$ ). The motor in the Prius is incapable of providing

adequate acceleration without assistance; this in turn requires that an internal combustion engine (ICE) be provided, and be connected to the wheels by way of a variable-ratio planetary gearset. Operation of the ICE in the Prius is thus constrained by the vehicle's torque requirements, which unacceptably complicates its operation and renders it incapable of maximally efficient operation.

Applicants assert, therefore, that according to the invention the components of the hybrid vehicles of the invention are to be sized so that the ratio between battery voltage under load to peak current is at least about 2.5, and preferably is at least 3.5 to 4 : 1; this allows adequate acceleration from low speeds without use of torque from the ICE, which in turn allows elimination of any multiple-speed or variable-ratio transmission, and allows the ICE to be declutched from the wheels except when the ICE can be employed efficiently to propel the vehicle (or the ICE is being motored during deceleration or coast-down, as above). In turn this requirement leads to operation at higher voltages than typical, to keep both average maximum and peak currents low, which provides the very significant advantages mentioned above.

#### Range-Broadening Transmission

As mentioned above, in some embodiments of the invention as disclosed by the present continuation-in-part application, a two-speed transmission may be provided to broaden the range of utility of the vehicle. An exemplary hybrid vehicle powertrain providing this and further additional features is shown in Fig. 14; where not otherwise described, this embodiment of the invention includes features in common with those discussed above in connection with the '970 patent and the '817 and '743 applications.

More specifically, according to one embodiment of this aspect of the invention of the present continuation-in-part application, the range of efficient use of the hybrid vehicle of the invention

is further broadened by providing a two-speed "range shifting" transmission, akin to those presently provided on SUVs and the like to allow shifting into a "low range", so that when the load is expected to be heavy for extended period of time, for example, when a heavy trailer is to be towed, the transmission can be operated to select the low range. As indicated, such a transmission would normally only be operated once per trip, and is accordingly not equivalent to a conventional multiple-speed transmission which is operated to provide a sequence of effective overall gear ratios each time the vehicle is accelerated, as suggested in numerous prior art references dealing with hybrid vehicles. However, in another embodiment, the two-speed transmission thus provided could be operated conventionally, i.e., shifted automatically during acceleration, or in "kick-down" mode responsive to the operator's demand for acceleration.

In one implementation of this aspect of the invention, as shown in Fig. 14, a planetary gearbox 33 is disposed between the output shafts from the traction motor 25 and the combination of engine 40 and starting motor 21. Gearbox 33 may be controlled directly by the operator, as conventional, or by the microprocessor 48, in response to an operator command or responsive to sensing that the road load has exceeded some predetermined value, e.g. 125% of MTO, for an extended time, e.g. several minutes, or conventionally, i.e., shifted under ordinary acceleration. Typically the gearbox 33 will be locked, providing a direct drive, under ordinary circumstances; when a lower ratio is needed, for example, when towing a heavy trailer, the gearbox 33 may be controlled to yield a reduction of 0.5 - 0.8 : 1.

Fig. 14 also shows a second traction motor 222 driving a second set of road wheels 210 through a second differential 211. This is a convenient way of providing a "four-wheel drive" hybrid vehicle, which avoids the fore-and-aft driveshaft and third differential needed by conventional four-wheel drive vehicles. In this embodiment, road wheels 210 are configured as the steering

wheels of the vehicle; accordingly halfshaft assemblies 212 incorporating universal joints are employed allowing wheels 210 to pivot, as illustrated. Traction motor 222 is connected to battery bank ("BB" in Figs. 14 and 15) via a further inverter/charger 224, controlled by microprocessor 48 essentially similarly to traction motor 25. As noted above, a DC-to-DC converter 223 may be provided to allow the vehicle of the invention to be connected to vehicles having conventional 12 volt electrical systems for emergency starting purposes, and to provide 12 VDC for operation of conventional accessories.

Provision of separate traction motors 222 and 25 with respect to the corresponding pairs of road wheels 210 and 34 has several advantages with respect to conventional vehicles; as noted above, the fore-and-aft driveshaft and third differential normally required are eliminated, freeing substantial space normally required by these components. Further, "traction control" -- that is, control of the amount of torque directed to each pair of wheels responsive to the traction conditions, which is useful in driving in snow or mud, or on wet or icy pavement -- is conveniently accomplished by the microprocessor, simply by monitoring the wheels' response to given amounts of current and reducing the current to spinning wheels.

As shown by Fig. 14, vehicles according to the invention provided with two traction motors and having a planetary gearbox 33 between one traction motor and its corresponding road wheels may have a similar gearbox 213 between the second traction motor 222 and its wheels; however, this second gearbox 213 is not expected to be commonly required. Similarly, second traction motor 222 can be configured as a high-RPM unit, with its output shaft connected to the road wheels through reduction gears 214. In this implementation starter motor/generator 21 is also shown connected to the road wheels through a reduction device 34, illustrated as a chain drive; as indicated above, providing a mechanical reduction between the various motors 21, 25, and 222 and the respective road



wheels is desirable in order that the motors can be selected and optimized to operate at higher speeds than engine 40.

Another possibility not shown specifically by Fig. 14, but within the scope of the invention, is to provide a "torque converter" of essentially conventional design, preferably fitted with a "lock-up" clutch, between the traction motor(s) and the corresponding wheels. As is well known, torque converters are commonly employed as part of automatic transmissions for passenger cars; the torque converter multiplies the input torque at low speeds. Such a torque converter would provide increased acceleration from rest. However, a similar effect can be obtained more simply by overdriving the traction motor(s) beyond their rated power for the first few seconds of acceleration.

#### Braking System

Numerous patents, including the '970 patent discussed above, recognize that one advantage of hybrid vehicles is that by appropriate control of electric motor/generators connected to the road wheels, a substantial fraction of the energy lost by conventional vehicles to friction can be recovered through regenerative braking, that is, by converting the vehicle's kinetic energy to stored battery power by using torque available at the road wheels to drive the motor(s) in generator mode, and storing the resulting electrical energy in the battery bank for use later. It is commonly estimated that most of the energy expended in accelerating the vehicle in city driving can be recovered in this way, since irrecoverable losses due to air resistance and rolling resistance contribute relatively little to the vehicle's energy demands at low speeds; by comparison, less of the energy expended to drive the vehicle at highway speeds can thus be recovered, although regenerative braking is nonetheless desirable.

More particularly, it is known to operate the motor/generator and cooperating inverter/charger electronics of hybrid vehicles so that electrical power is generated and stored in the battery bank

when the operator desires to slow the vehicle. Accordingly "regenerative braking" *per se* is known. It is generally also apparent to those of skill in the art that a conventional mechanical braking system must also be provided, both for safety in the event of a failure in the regenerative braking system and to provide braking in the event the battery bank is fully charged; that is, it is important to avoid overcharging the battery bank in order to maximize its useful life. See Boll U.S. patent 5,788,597 and Frank U.S. patent 5,842,534. Similarly, mechanical braking is also needed when regenerative braking is not possible, e.g., at a stop. However, the art known to the inventors does not address all the concerns relevant to provision of a braking system of a hybrid vehicle, and to do so is another object of the present invention. See, e.g., Mikami et al patent 5,839,533, which suggests employment of engine braking (i.e., retardation of the vehicle using torque due to compression of air in the engine, and friction therein) as well as regenerative braking. The choice between the two is apparently to be made by the operator, at least in part responsive to the battery's state of charge. This would be far too complex for general acceptance.

The disclosure of the Boll patent itself is directed to optimizing the use of regenerative, engine, and mechanical braking. Boll also recognizes the desirability of maintaining a consistent brake pedal "feel" in the various brake modes.

German patent application DT 19 05 641 B2 to Strifler discloses a combined regenerative and mechanical braking system for an electric vehicle, wherein regenerative braking is effected upon the operator's first operating a brake lever, and mechanical braking is further effected upon reaching the maximum regenerative braking effect. If the battery cannot accept further charge, the mechanical braking is triggered relatively earlier, so that the operator experiences substantially the same pedal "feel" regardless whether regenerative or mechanical braking is being implemented.

The present invention also recognizes that providing proper

brake "feel" to the operator is important to provision of a satisfactory vehicle, but differs substantially from the teachings of the art, and the Boll and Strifler references in particular, in the type of pedal feel preferred.

5 More particularly, it will be appreciated that typical vehicle mechanical brake systems provide a relatively linear relationship between the force exerted on the brake pedal and the retarding force exerted on the wheels by the brakes. It is essential that this relatively linear relationship be provided by the brake system  
10 of any hybrid vehicle, so that the operator can smoothly and controllably brake the vehicle as desired.

Providing a relatively linear relationship between the force exerted on the brake pedal and the retarding force exerted on the tires by the brakes is substantially straightforward in the case of  
15 conventional mechanical braking systems. It is much more complicated in the case of a brake system incorporating regenerative braking as described above, since such a system must provide a linear relationship between the force exerted on the brake pedal and the retarding force exerted on the tires by the  
20 brakes and motor/generator(s) under all circumstances. The problem is particularly complicated during transitions from one braking regime to another. For example, if regenerative braking is used to commence deceleration but hydraulic braking must take over, e.g., if the battery bank's state of charge becomes full during a long  
25 descent, or if a leisurely stop suddenly becomes abrupt, the braking regime must change smoothly and controllably. Regenerative braking is also not available when the vehicle is moving very slowly or is at rest, and mechanical brakes must be available under these circumstances.

30 In addition to maintenance of the linear relationship, it is deemed preferable by the present inventors that the operator be made aware by a change in the "feel" of the brake pedal that regenerative braking is not available, typically due to the battery bank's state of charge becoming full. As noted, this is contrary to

the teachings of the Boll patent and the Strifler German application. More specifically, it is considered desirable by the inventors that the brake pedal resist depression by the operator to a degree proportional to the amount of regenerative braking actually being effected at all times.

Finally, it will be appreciated that the engine manifold vacuum as conventionally used to produce "power braking", i.e., servo assistance, is not available to a hybrid vehicle if the engine is not running; some other source of power for servo assistance is required in order that brake effort is not unacceptably high.

Fig. 15 shows schematically the principal components of a brake system for a hybrid vehicle that addresses the concerns above. Where common reference numerals are employed, the components are common with those shown in other Figures, while components not important to understanding of the braking system are omitted for simplicity. Thus, Fig. 15 shows traction motors 222 and 25 connected directly to the respective road wheels 210 and 34 respectively, omitting the other components discussed above. (In vehicles where a single traction motor drives a single pair of wheels, the improvements described herein would be provided as to these, while a four-wheel hydraulic braking system would also be provided.) As also discussed above, motors 222 and 25 are connected to battery bank 22 through respective inverter/chargers 224 and 27. Inverter/chargers 224 and 27 are controlled by microprocessor 48 to operate so that the motors can draw power from battery bank 22 and impart torque to the respective wheels to propel the vehicle in the appropriate modes of vehicle operation; during regenerative braking, inverter/chargers 224 and 27 are controlled so that the motors absorb torque from the wheels, slowing the vehicle, and storing the power thus generated in the battery bank 22.

Control of the inverter/chargers and motors to absorb a desired amount of torque from the wheels in response to a braking

command from microprocessor 48 is considered to be within the skill of the art. The command itself may be determined by microprocessor 48 responsive to the degree to which brake pedal 70 is depressed, as measured by a potentiometer or similar device, indicated at 71. However, according to the invention, as above, a device is provided which varies the "feel" of the pedal (essentially its resistance to being depressed by the driver) responsive to the degree regenerative braking is in fact being implemented, thereby providing tactile feedback to the driver enabling smooth deceleration and, when appropriate, also providing an indication that regenerative braking is not available.

In the implementation of the invention shown, controllable resistance to the movement of brake pedal 70 is provided by connecting it to a microprocessor-controlled pneumatic cylinder assembly 230. A piston 232 fitting within a pneumatic cylinder 238 is driven by a connecting rod 234 attached to pedal 70 by a clevis 236. As the pedal is depressed, moving from right to left in Fig. 15, i.e., from the position shown in full to that shown in dotted lines, piston 232 expels air from the interior of cylinder 238 via vent 240. The rate at which air is expelled in response to any given pedal pressure is controlled by the spacing of a needle valve 242 from a seat 244; the needle valve 242 is moved closer to its seat 244 to increase the resistance to airflow, or moved away from seat 244 to reduce the resistance. The spacing is controlled by microprocessor 48 in order to vary the feel of the brake pedal 70; in the implementation shown, the needle valve 242 is threaded into the body in which valve seat 244 is formed, and the spacing is controlled by the microprocessor 48 by commands sent to a motor 248 rotating the needle valve 242 through a pair of gears 250. A spring 252 may be provided to return the pedal to its initial position. Thus, for example, if regenerative braking is not available, needle valve 242 is opened, so that the cylinder provides little resistance to the pedal, effectively informing the driver that only hydraulic braking is available. When regenerative braking is

initiated, responsive to the microprocessor's detecting a signal from potentiometer 71, the needle valve is closed responsive to the degree of braking provided, resisting motion of the pedal 70, and so that the pedal feel provided to the operator is responsive to the degree of regenerative braking actually being effected. Obviously, numerous other arrangements to thus controllably vary the feel of the brake pedal will occur to those of skill in the art.

The mechanical design of the hydraulic braking system of the hybrid vehicle according to the invention is generally conventional, with two principal exceptions as follows: First, as the engine is not always running during movement of the hybrid vehicle, there is no consistent source of manifold vacuum as conventionally employed to provide servo assistance to braking. Therefore, a motor 254 powered directly by the battery bank BB is provided, and drives a vacuum pump 256, providing vacuum to a conventional servo booster 258, in turn operating conventional wheel brakes 260. The same motor 254 can be used to power other "ancillary" systems that in conventional vehicles are powered by the engine, such as the power steering pump and the air conditioning compressor. (The art does recognize that hybrid vehicles require different sources of power for ancillary devices, such as power steering pumps or power brake pumps. See Heidl patent 5,249,637, at col. 1, lines 7 - 45.) Second, in order that the initial movement of the brake pedal 70 activates only the regenerative braking process (in order to obtain the maximum benefit therefrom), a mechanism is provided so that the rod 262 actuating the piston within master cylinder 264 and thence the wheel brakes 260 moves a distance X before the master cylinder itself is actuated. In the implementation shown, this mechanism simply involves provision of a cross-pin 266 fixed to rod 262 and sliding within a slot 268 formed in the piston rod 270 of master cylinder 264; accordingly, the master cylinder piston(s) do not begin to move until the cross-pin 266 reaches the left end of slot

268. If the overall pedal travel Y is six inches, the distance X defined by slot 268 may be such as to allow pedal 70 to move freely through 1-1/2 inches before the piston(s) of the master cylinder 264 begins to move.

5 Thus, according to this aspect of the invention, potentiometer 71 provides a signal to the microprocessor 48 when the brake pedal 70 is depressed by the driver. The microprocessor 48 evaluates the battery bank state of charge (SOC) as indicated at 66; unless this is such that further charging is undesirable, the inverter/chargers 10 224 and 27 are operated such that motors 222 and 25 are operated as generators, so that torque provided to the wheels by the road is converted into electrical power, retarding the vehicle and charging the battery bank. The degree of retardation thus provided depends on the degree to which pedal 70 is depressed. The driver feels 15 resistance to depressing the pedal from air resistance controlled by the opening of needle valve 242; microprocessor 48 controls the opening of valve 242 so that the pedal feel corresponds to the degree of regenerative braking that is provided. In the event regenerative braking is not available for some reason, perhaps 20 because the battery bank is fully charged, because of some flaw in the charging circuits, or because the vehicle is stopped, valve 242 is opened, so that the driver feels little resistance to initial pedal travel, until the hydraulic brake system is activated.

25 It will be apparent that other types of devices for controlling the resistance to pedal travel to correspond to the amount of regenerative braking being provided, and thus to provide the desired linear relationship between pedal resistance and vehicle retardation, could be substituted for the pneumatic cylinder with microprocessor-controlled vent device shown. For 30 example, a device controllably varying the friction between the pedal pivot and its mounting structure could be provided; a hydraulic system, similarly controlling the resistance to flow of a fluid through an orifice, might be provided; or a device varying the preload of a return spring might be provided. Other equivalent

devices for achieving the same goals will occur to those of skill in the art.

5            HVAC System

10            The essential components of the heating, ventilation and air conditioning (HVAC) systems of conventional vehicles are a heater core, connected to the engine cooling system, an air conditioning system including an evaporator, and a fan to blow air over the  
15            heater core and evaporator and into the passenger cabin. There are several issues to be addressed in adapting the conventional automotive HVAC system to use in a hybrid vehicle. One is that conventionally the air conditioning compressor is driven by the engine through an electrically-controlled clutch; in a hybrid  
20            vehicle this is unacceptable, as the engine is not run constantly. Therefore the air conditioning compressor must be powered differently. Similarly, again as the engine is not run constantly, the heater core cannot be relied upon to heat the cabin.

25            The art does recognize that hybrid vehicles require different sources of power for ancillary devices, such as power steering pumps or power brake pumps. See Heidl patent 5,249,637, at col. 1, lines 7 - 45. Heidl's disclosure is to the effect that a motor/generator used to drive the ancillaries during electric operation can be used as a generator when the vehicle is propelled  
30            by an internal combustion engine.

35            Fig. 16 shows the principal components of an HVAC system for a hybrid vehicle according to the invention. The complex ducting that is typically provided to supply conditioned air throughout the vehicle cabin is represented by a single duct 300. A fan 302 forces air through the duct 300, and in succession past an evaporator 304, a heater core 306, and an electric heater 308. The evaporator 304 is connected to an air conditioning compressor 310 driven by an electric motor 312 powered from the battery bank, so that the air conditioning system can be operated independent of the



engine 40.

Motor 312 could be the same motor used to power other ancillaries, such as the vacuum pump 256 (Fig. 15) used to provide servo assistance to the brake system, or could be a separate motor dedicated to powering the compressor 310. The latter may be preferred, as this would allow elimination of the clutch otherwise needed to permit operation of the compressor only when needed; elimination of the clutch would also allow elimination of seals that are a source of leaks. Another advantage of driving the compressor from the battery bank according to the invention is as follows. Conventionally, in order to be useful under all circumstances, the compressor must be sized to provide full cooling with the engine at idle. Such a compressor is very inefficient at higher speeds; by decoupling the compressor from the vehicle drivetrain according to the invention, it can be designed to be driven by motor 312 at a single optimally efficient speed. Cabin temperature can be thermostatically controlled by a throttling valve controlling the flow of refrigerant, or by turning motor 312 on and off as required. The other components of the air conditioning system, including an expansion valve 314 and a condenser 316, are shown schematically, and are generally conventional.

When the engine is running, it is efficient to employ waste heat from the engine cooling system to provide cabin heat, and accordingly an essentially conventional heater core 306 and control elements (not shown) are provided; heater core 306 is downstream of the evaporator 304 with respect to the flow of air through duct 300, as conventional, so that dehumidified air can be heated to provide efficient demisting.

In order to provide heat as may be required when the engine is not running, an electric heating element 308, essentially comprising a coil of Nichrome wire or the like, is provided, again downstream of the evaporator 304. Heating element 308 is provided with conventional controls (not shown) and is powered directly from

the battery bank 22, as indicated.

It will be appreciated that according to this aspect of the invention, suitably heated or cooled cabin air is thus available regardless of the mode of operation of the vehicle, as needed in order that the hybrid vehicle of the invention suffers no comfort or convenience drawback with respect to conventional vehicles. Indeed, because ample electrical power is available from the large battery bank of the hybrid vehicle, electric heater 308 can be designed to heat the cabin much more rapidly than does the coolant heat exchanging core of a conventional engine, thus providing a convenience advantage. Similarly, conductors can be embedded in the vehicle windows and windshield and powered by the battery bank for improved electrically-operated de-misting and de-icing.

It will be appreciated that the hybrid vehicle and operational strategy therefor of the invention provide numerous advantages over the prior art discussed herein, and that further improvements and modifications thereto are within the skill of the art. Accordingly, while a preferred embodiment of the invention has been disclosed, and various alternatives mentioned specifically, the invention is not to be limited thereby.

1. In a method of controlling an internal combustion engine of a hybrid vehicle, said engine being operatively connected to drive wheels of said vehicle through a clutch, said vehicle further comprising a traction motor operatively connected to drive wheels of said vehicle, a starter/generator motor operatively connected to said engine for starting said engine and for providing electrical power in response to torque from said engine, a battery bank adapted to store electrical energy to power said traction motor and to start said engine, at least one inverter/charger adapted to cooperate with said traction motor and said starter/generator such that said traction motor can be operated to provide torque to said road wheels responsive to electrical power from said battery bank, or to provide electrical power to said battery bank responsive to torque from said road wheels, and such that said starter/generator can be operated to provide torque to start said engine, or to provide electrical power to said battery bank responsive to torque provided by said engine, and a microprocessor adapted to control operation of said engine, said traction motor, said starter/generator, and said at least one inverter/charger, so as to control flow of torque and electrical power therebetween in response to sensed parameters, the improvement comprising:

establishing at least four vehicle operating modes, including:

a mode I, wherein said engine is not operated and said vehicle is propelled by torque from said traction motor in response to electrical power drawn from said battery bank;

a mode II, wherein said vehicle is propelled by torque from said traction motor in response to electrical power drawn from said battery bank, and said starter/generator is driven by torque provided by said engine to provide electrical power to recharge said battery bank;

a mode III, wherein said vehicle is propelled by torque from said engine;

a mode IV, wherein said vehicle is propelled by torque from

35 said engine and from said traction motor in response to electrical  
power drawn from said battery bank;

40 wherein said microprocessor controls operation of said engine,  
said traction motor, said starter/generator, and said at least one  
inverter/charger in response to the instantaneous torque demands  
(RL) of said vehicle, and such that said engine is operated only in  
response to a load equal at least to a predetermined minimum value  
of its maximum torque output.

5 2. The method of claim 1, wherein said starter/generator is  
sized with respect to said engine such that said starter/generator  
is capable of being driven by said engine in said mode II while  
said engine produces at least about 30% of its maximum torque  
output.

5 3. The method of claim 2, wherein said battery bank is sized  
such that the charging current supplied by said starter/generator  
in response to torque from said engine while producing at least  
about 30% of its maximum torque output is no more than about 50  
amperes.

4. The method of claim 1, wherein said microprocessor controls  
operation of said vehicle such that said mode III is entered only  
when RL is at least equal to a predetermined fraction of the  
engine's maximum torque output (MTO).

5. The method of claim 4, wherein mode III is entered only  
when RL is substantially equal to at least 30% of MTO.

6. The method of claim 5, wherein said vehicle is operated in  
mode III while  $30\% < RL < 100\%$  of MTO.

7. The method of claim 1, wherein mode IV is entered only when  
RL > 100% of MTO.

8. The method of claim 1, wherein said vehicle further comprises a turbocharger adapted to be controlled by said microprocessor so as to increase the torque output of said engine from its maximum value while normally aspirated (MTO), and wherein a further vehicle operating mode V is established, wherein said turbocharger is controlled to operate when RL is greater than MTO for more than a given period of time T.

9. The method of claim 8, wherein if said vehicle is in said mode IV, with RL between 30 and 100% of MTO, and if RL then exceeds 100% of MTO, torque required in excess of 100% of MTO is initially provided by said traction motor, and if RL continues to exceed 100% of MTO for more than a given period of time T, said turbocharger is activated by said microprocessor such that said engine produces torque in excess of 100% of MTO.

10. A brake system for a hybrid vehicle, said vehicle comprising a drive train including an internal combustion engine operated to provide vehicle propulsive torque only during predetermined modes of operation of said vehicle and at least one traction motor and corresponding inverter/charger adapted to provide vehicle propulsive torque during predetermined modes of operation of said vehicle and to provide electrical energy responsive to torque from wheels of said vehicle during a regenerative braking mode of operation of said vehicle, a battery bank adapted to provide electrical energy to said motor as required and to accept charging energy from said motor when operated as a generator during said regenerative braking mode of operation of said vehicle, and a microprocessor for controlling the mode of operation of said vehicle, said brake system comprising:

a brake pedal adapted to be operated by a driver of said vehicle,

a hydraulic brake system coupled to said brake pedal and comprising at least one master cylinder and a number of wheel

20 brakes operatively connected to said master cylinder for retarding  
said vehicle upon actuation of said pedal,

a sensor for providing a signal to said microprocessor  
responsive to motion of said brake pedal,

a sensor for providing a signal to said microprocessor  
responsive to the state of charge of said battery bank,

25 a device controllable by said microprocessor to vary the  
resistance to motion of said pedal during braking responsive to the  
amount of regenerative braking being provided,

wherein said microprocessor controls the amount of  
regenerative braking provided upon motion of said pedal responsive  
30 to the state of charge of said battery bank, and controls the  
resistance to motion of said pedal during braking responsive to the  
amount of regenerative braking being provided.

11. The brake system of claim 10, wherein said device  
controllable by said microprocessor to vary the resistance to  
motion of said pedal during braking responsive to the amount of  
regenerative braking being provided comprises a pneumatic cylinder  
5 having a piston sliding therein, said piston being operated by said  
brake pedal, and comprising a vent passage including an orifice  
controllable by said microprocessor to control the resistance to  
motion of said pedal.

12. The brake system of claim 10, wherein said at least one  
master cylinder is coupled to said brake pedal by an actuating rod  
arranged so that said pedal can be moved through a predetermined  
distance before said master cylinder begins to apply pressure to  
5 said wheel brakes.

13. The brake system of claim 10, wherein said hydraulic  
brake system comprises a servo actuator and a vacuum pump driven by  
a motor responsive to electrical power supplied from said battery  
bank.

14. A heating, ventilation, and air conditioning (HVAC) system for a hybrid vehicle, said vehicle comprising a drive train including an internal combustion engine run only during predetermined modes of operation of said vehicle and at least one traction motor adapted to provide vehicle propulsive torque during predetermined modes of operation of said vehicle, a battery bank adapted to provide electrical energy to said motor as required, said HVAC system comprising:

a duct having a fan disposed therein for forcing air along said duct;

an evaporator in said duct;

an air conditioning compressor connected to said evaporator, and driven by an electric motor powered by said battery bank;

a heater core in said duct and connected to a cooling system of said engine; and

an electrical heating element in said duct and connected to said battery bank.

15. The HVAC system of claim 14, wherein said evaporator is disposed in said duct upstream of said heater core and said electrical heating element with respect to the direction of air flow through said duct.

16. A method for determining the relative sizes of the internal combustion engine, starting/charging and traction motors, and battery bank of a hybrid vehicle comprising said components, said method comprising the steps of:

a. selecting an internal combustion engine having sufficient torque to drive the vehicle without trailer at medium to high speed along a moderate grade;

b. sizing the starting/charging motor to provide an engine load during battery charging equal to at least approximately 30% of the engine's maximum torque output;

c. sizing the traction motor to provide adequate torque

at zero speed to overcome the maximum grade specified from rest, with the starter motor assisting as needed;

15 d. determining the maximum power drawn by the selected motor under full power conditions;

e. calculating the battery voltage under load that will be required to provide the power to be drawn by the motor(s) under full power conditions, and so that the ratio of the battery voltage under load to the peak current drawn by the motor(s) is  
20 at least 2.5:1, and

f. selecting the battery bank to provide the calculated voltage under peak load conditions.



#### ABSTRACT OF THE DISCLOSURE

A hybrid vehicle comprises an internal combustion engine, a traction motor, a starter motor, and a battery bank, all controlled by a microprocessor in accordance with the vehicle's instantaneous torque demands so that the engine is run only under conditions of high efficiency, typically only when the load is at least equal to 30% of the engine's maximum torque output. In some embodiments, a turbocharger may be provided, activated only when the load exceeds the engine's maximum torque output for an extended period; a two-speed transmission may further be provided, to further broaden the vehicle's load range. A hybrid brake system provides regenerative braking, with mechanical braking available in the event the battery bank is fully charged, in emergencies, or at rest; a control mechanism is provided to control the brake system to provide linear brake feel under varying circumstances.

FIG. 1  
(PRIOR ART)

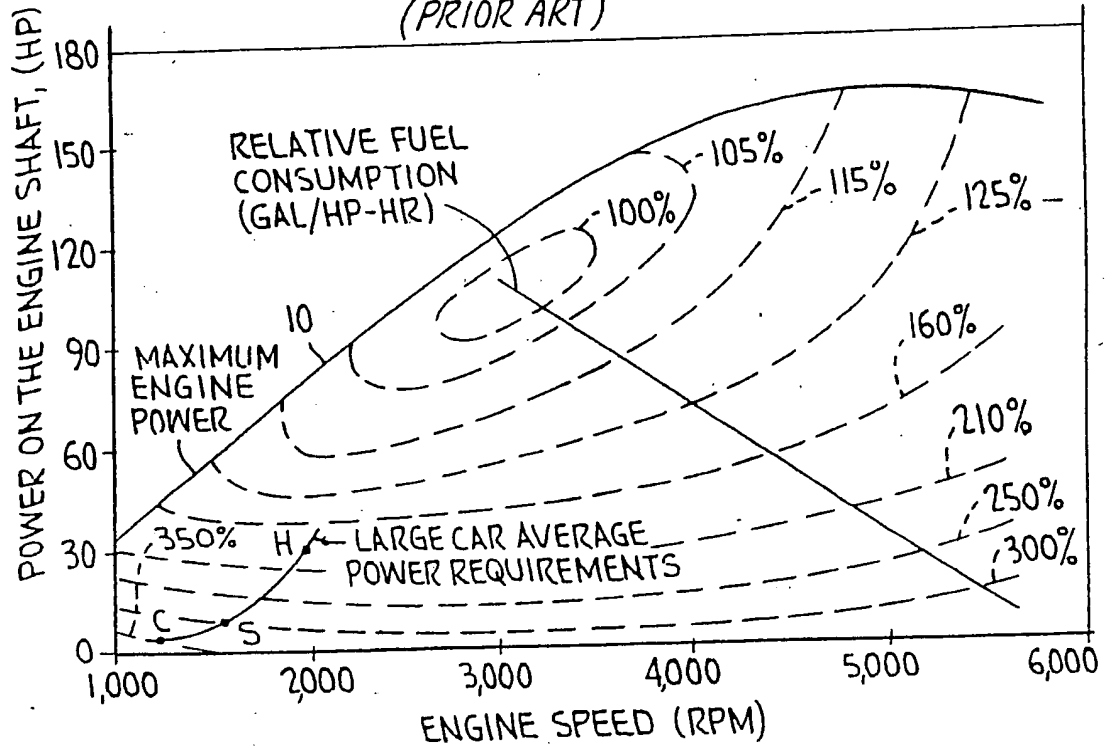
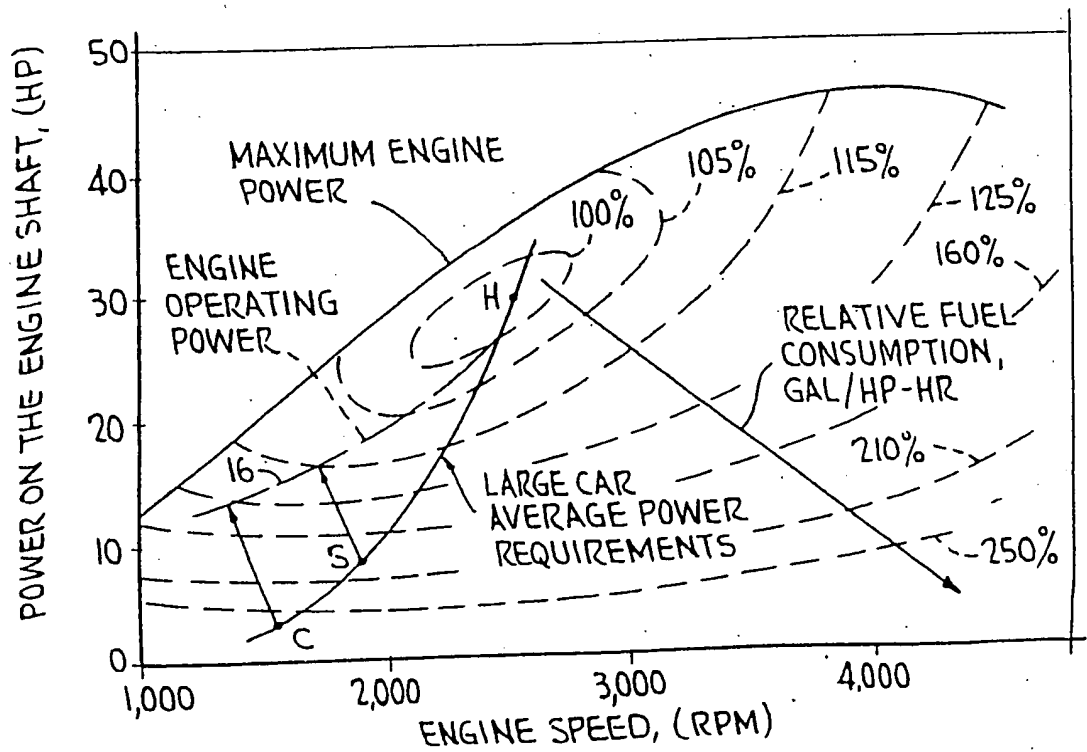

FIG. 2



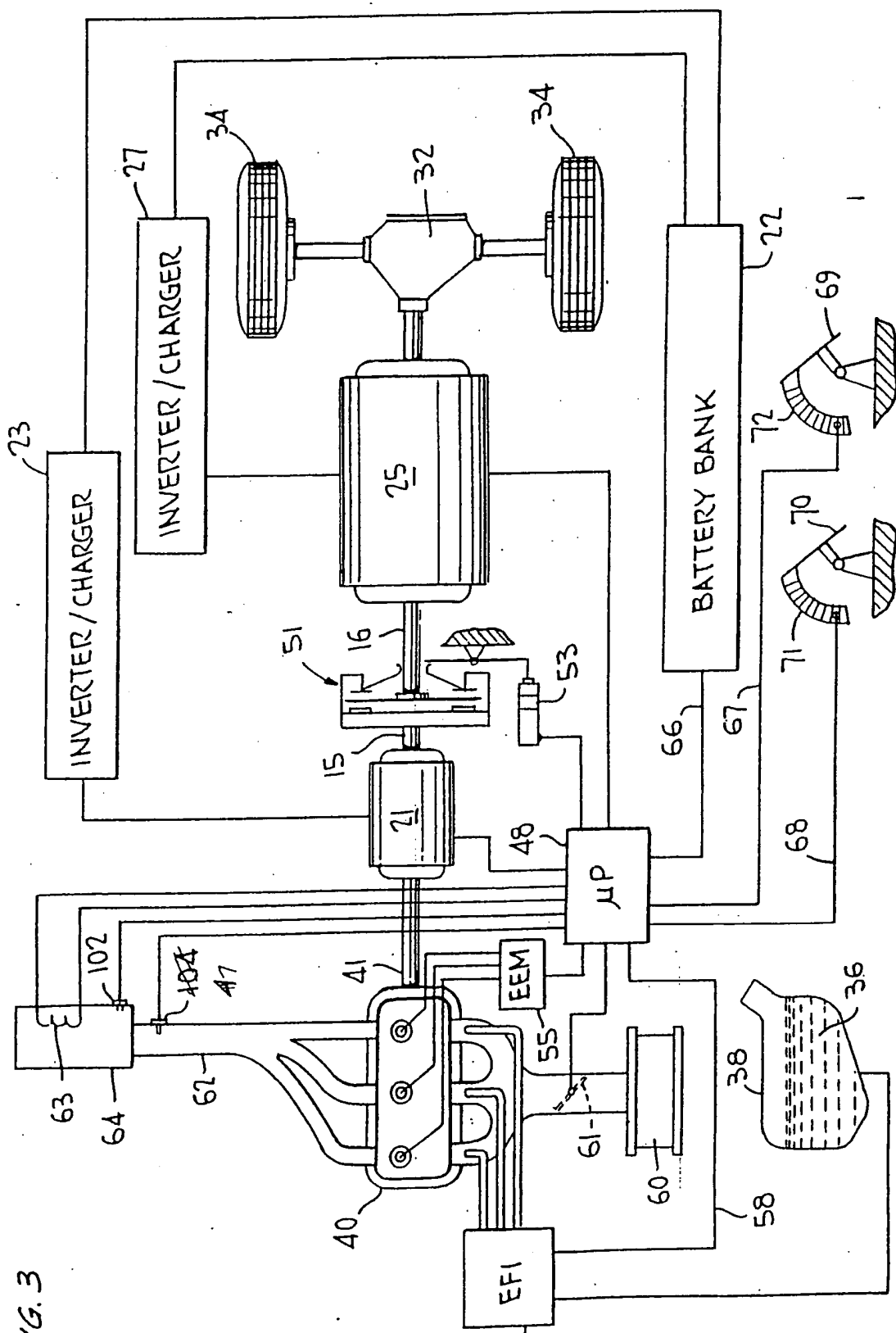

FIG. 3

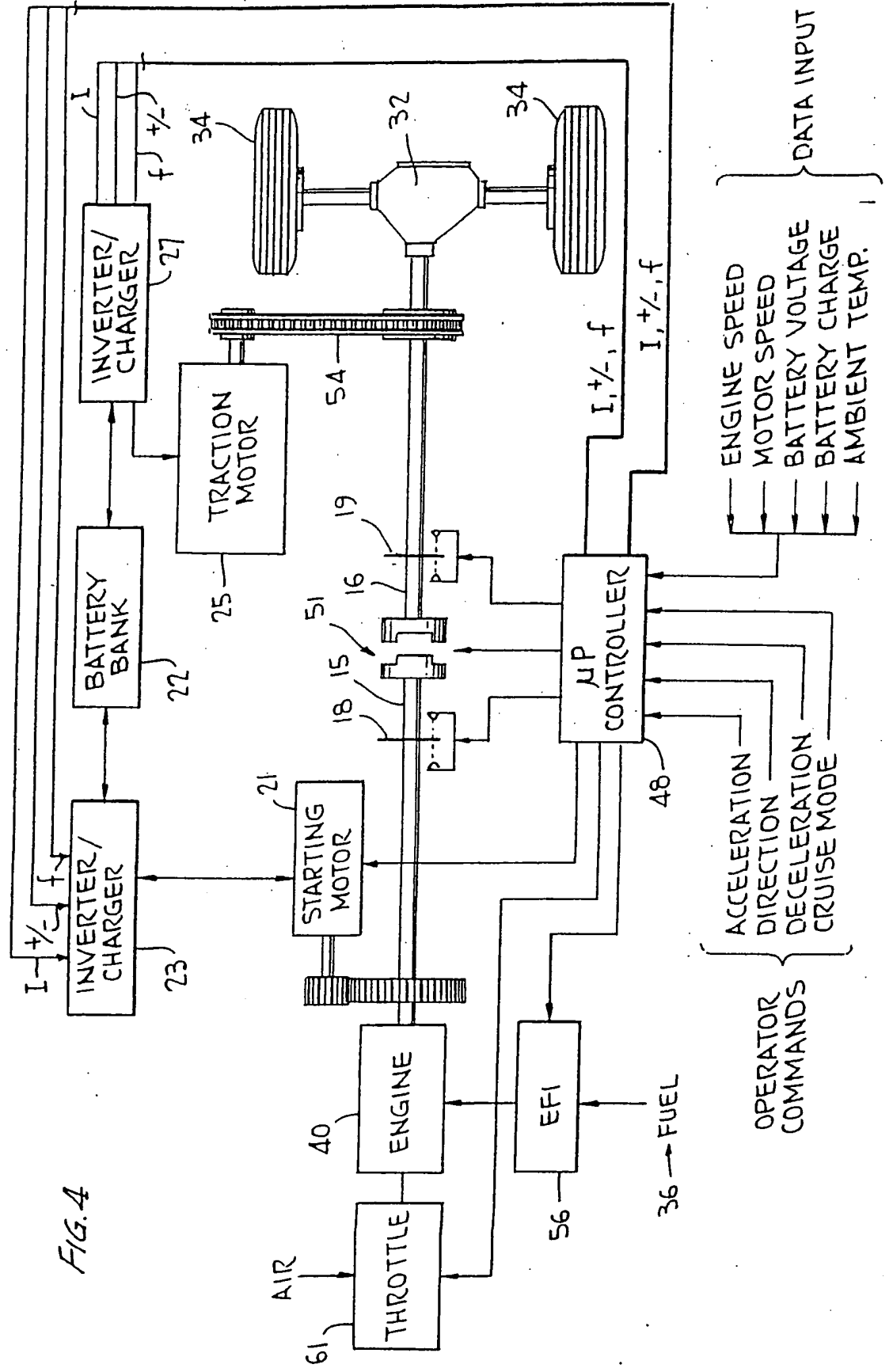

FIG. 4

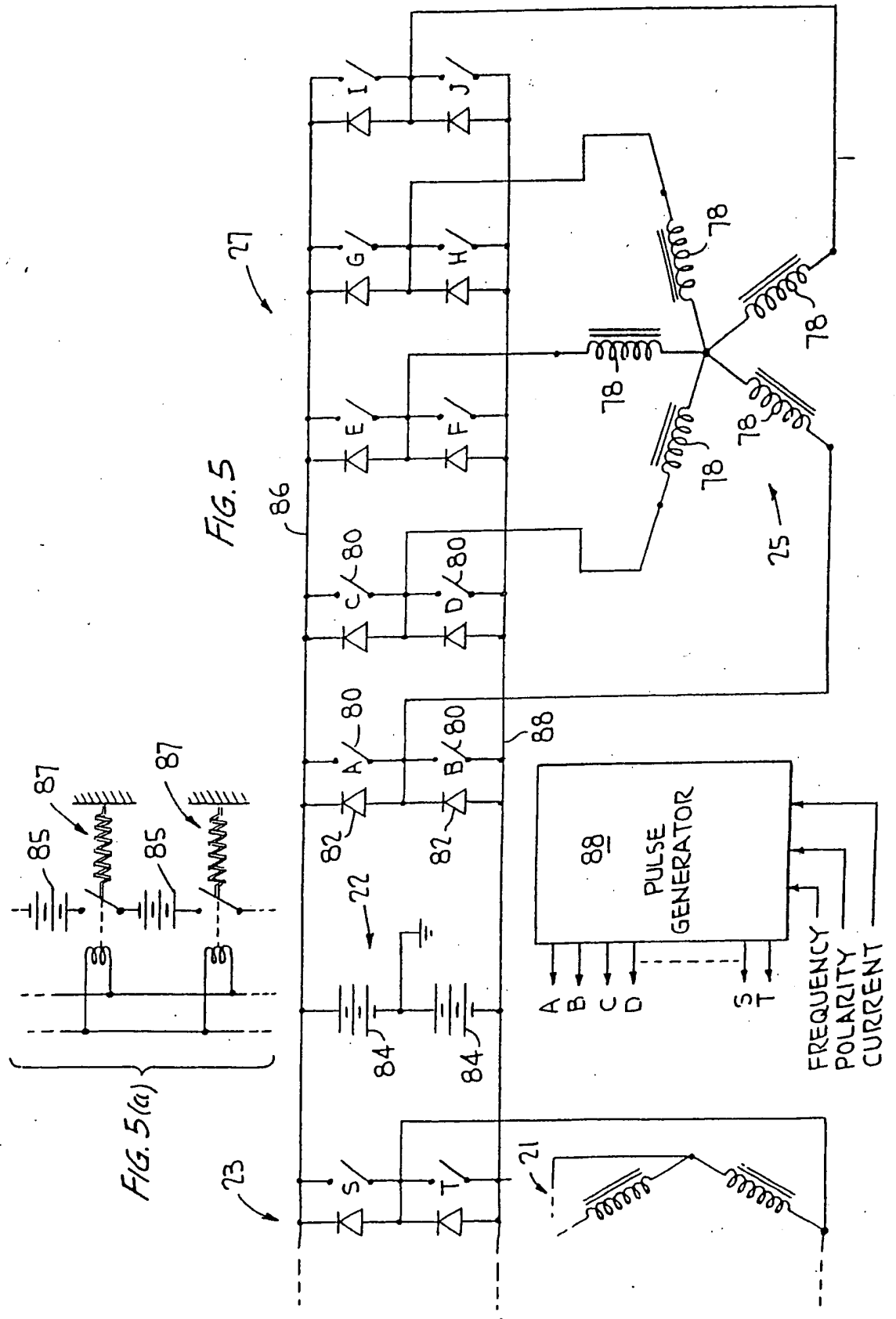
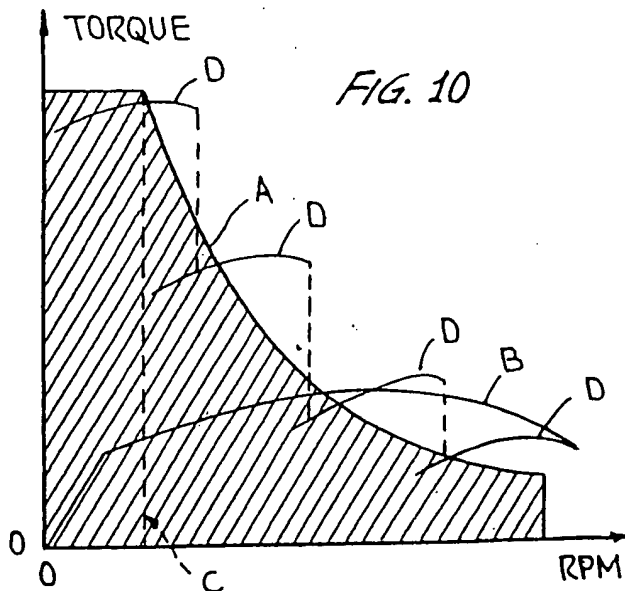
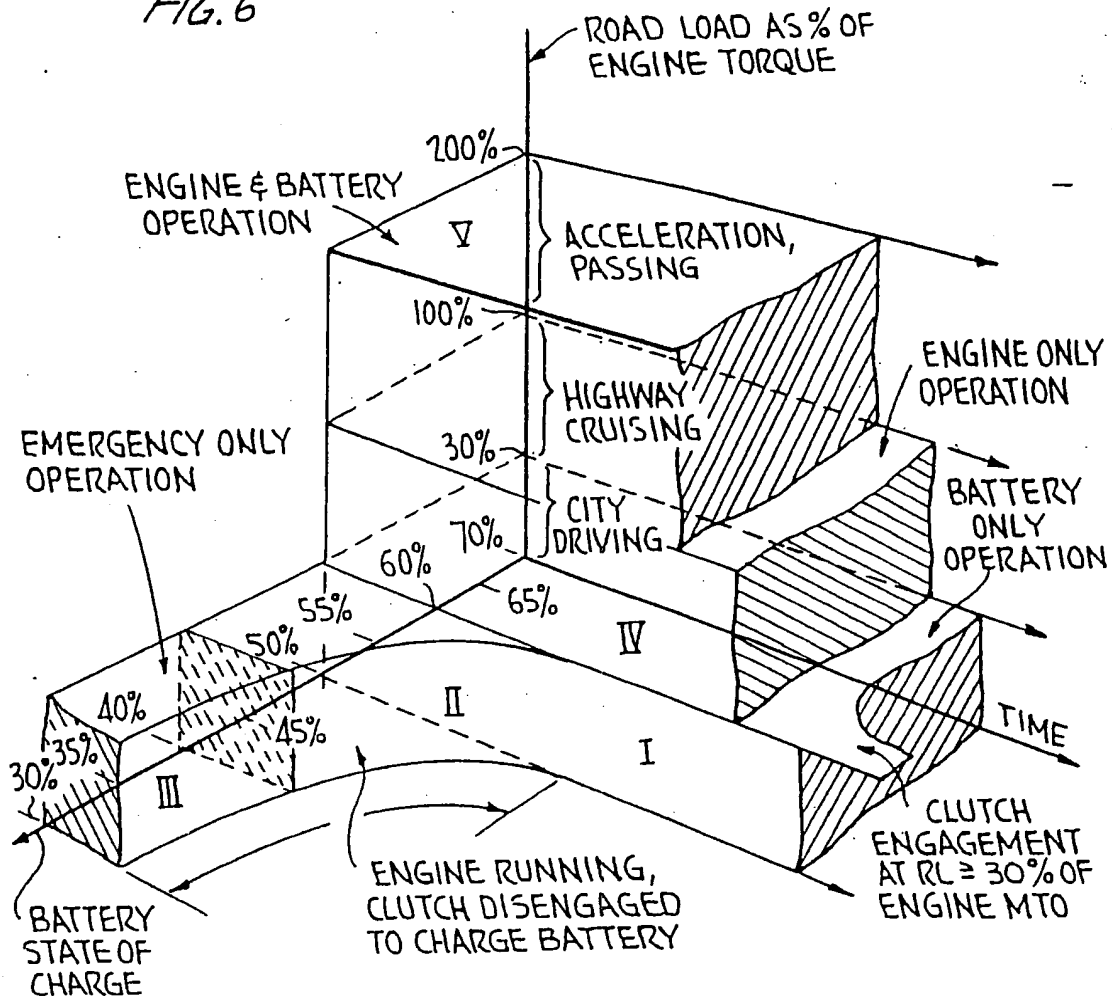

FIG. 6



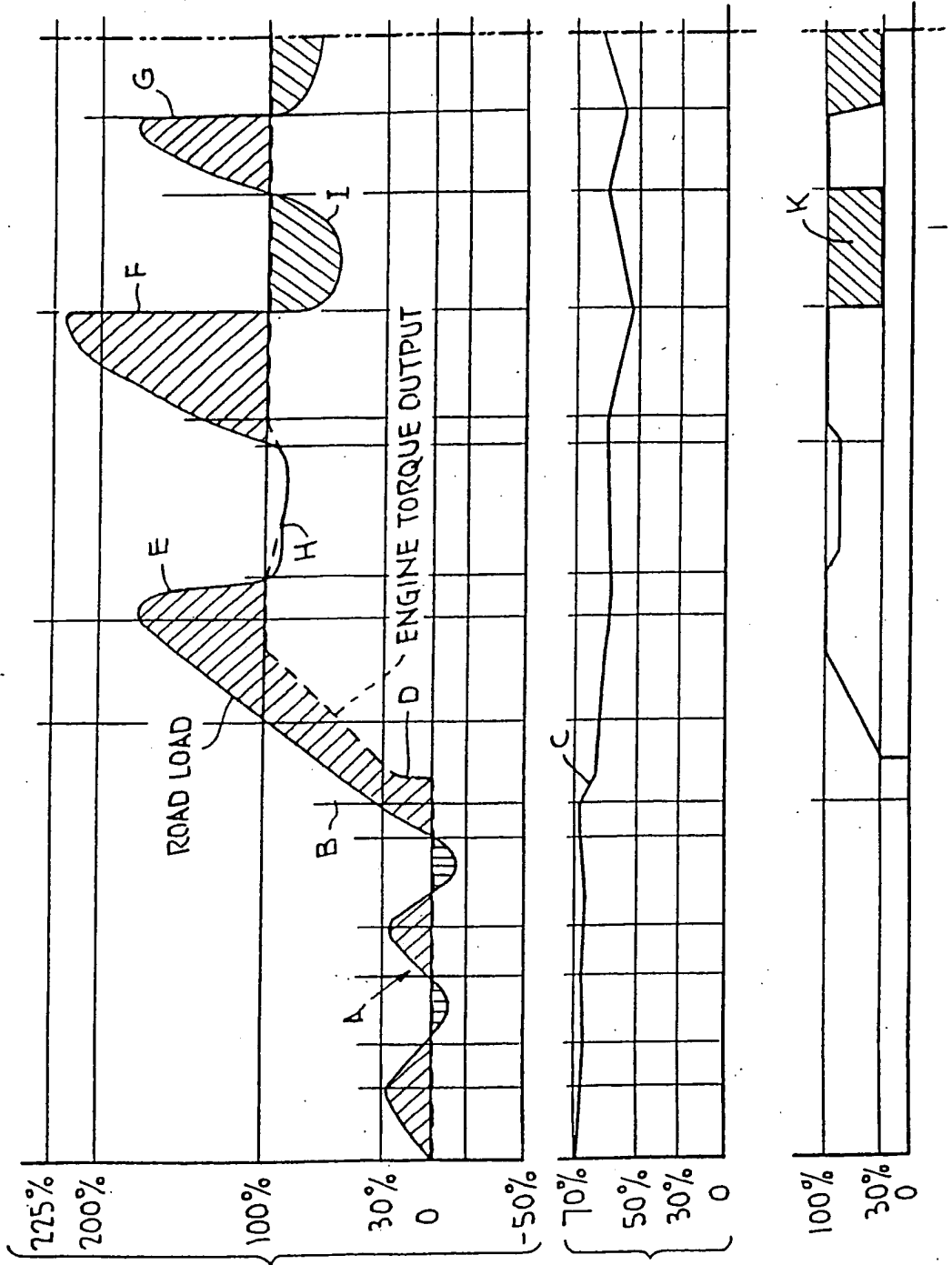

FIG. 7(a)  
ROAD LOAD AS %  
OF MAX. ENGINE  
TORQUE OUTPUT  
(% MTO)

FIG. 7(b)  
BATTERY BANK  
STATE OF CHARGE  
(BSC)

FIG. 7(c)  
ENGINE TORQUE  
OUTPUT

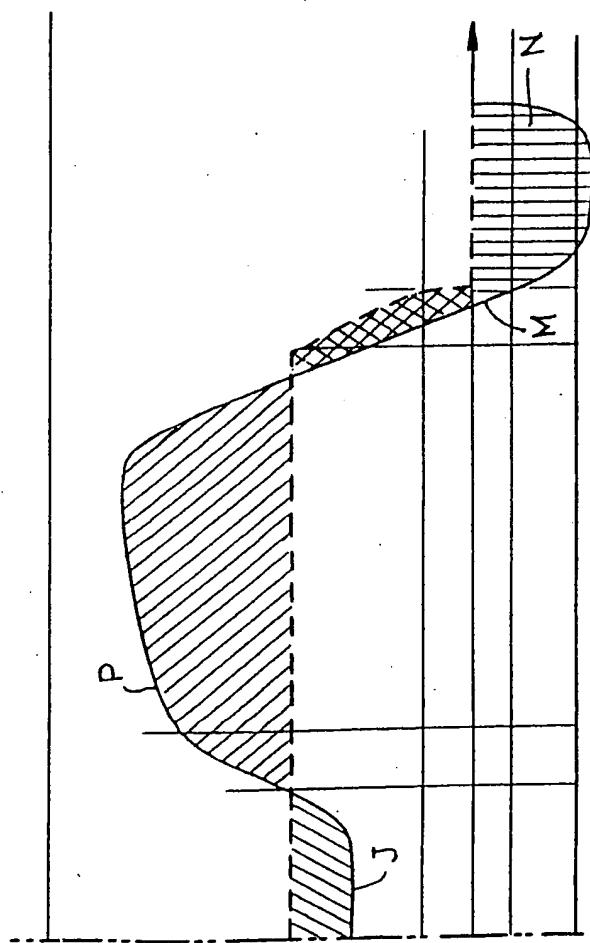

FIG. 7(a)  
(CONTINUED)

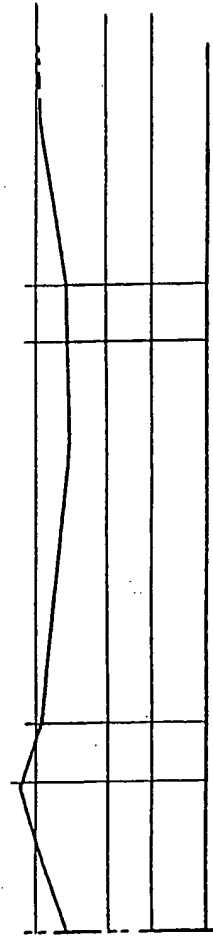

FIG. 7(b)  
(CONTINUED)

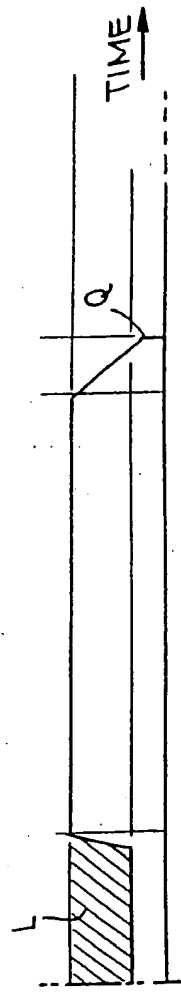

FIG. 7(c)  
(CONTINUED)



8/17

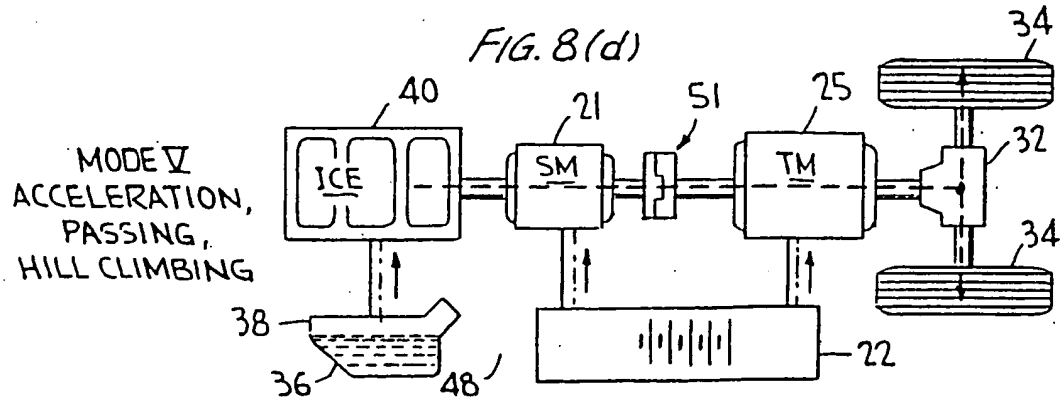
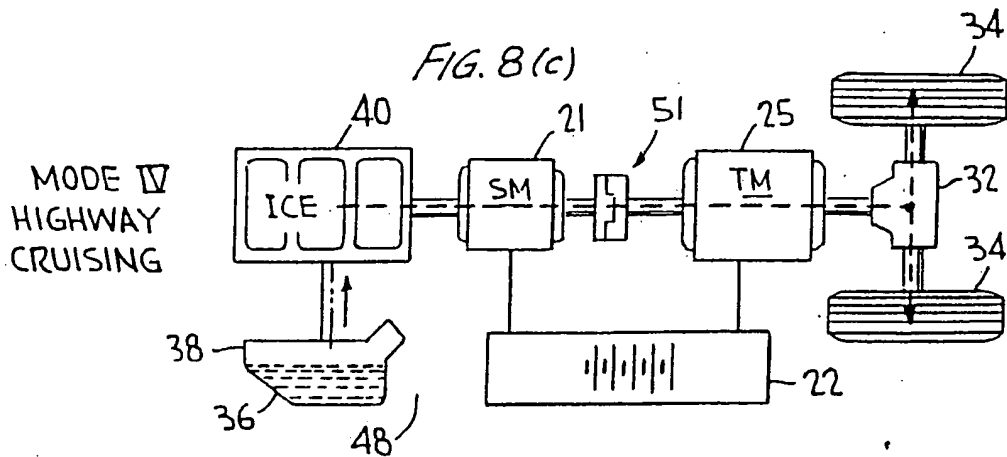
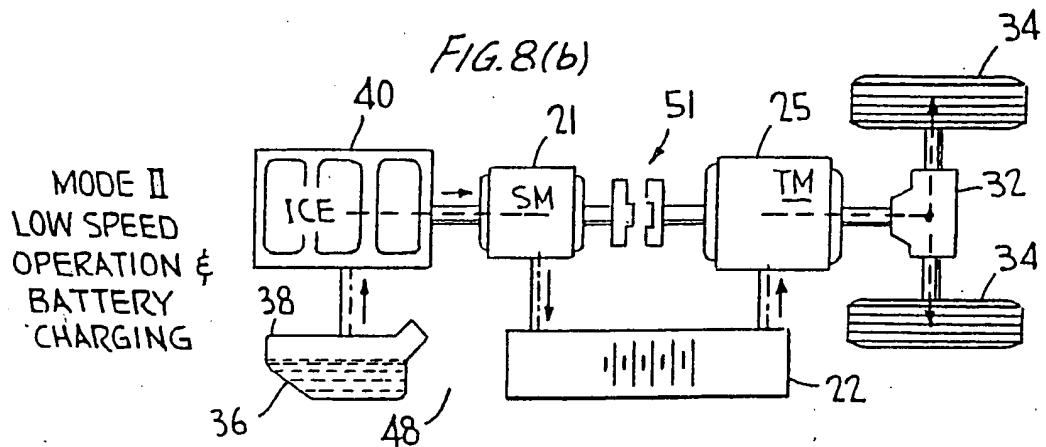
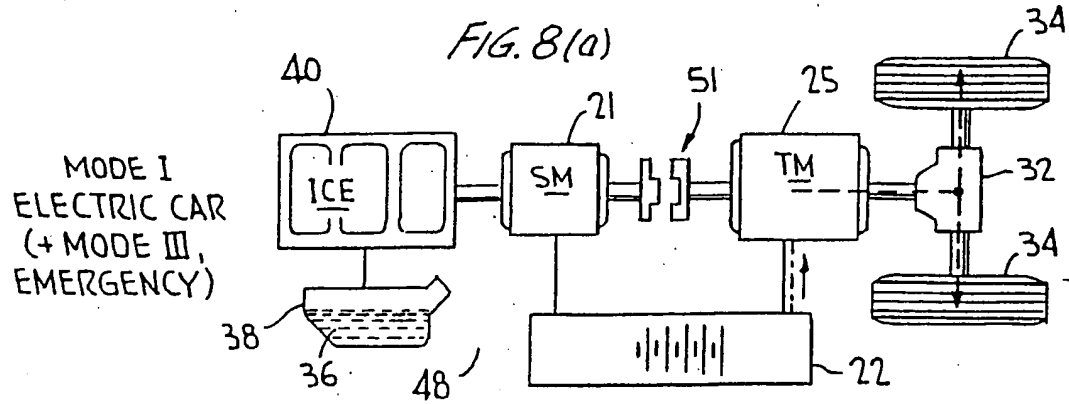

FIG. 9

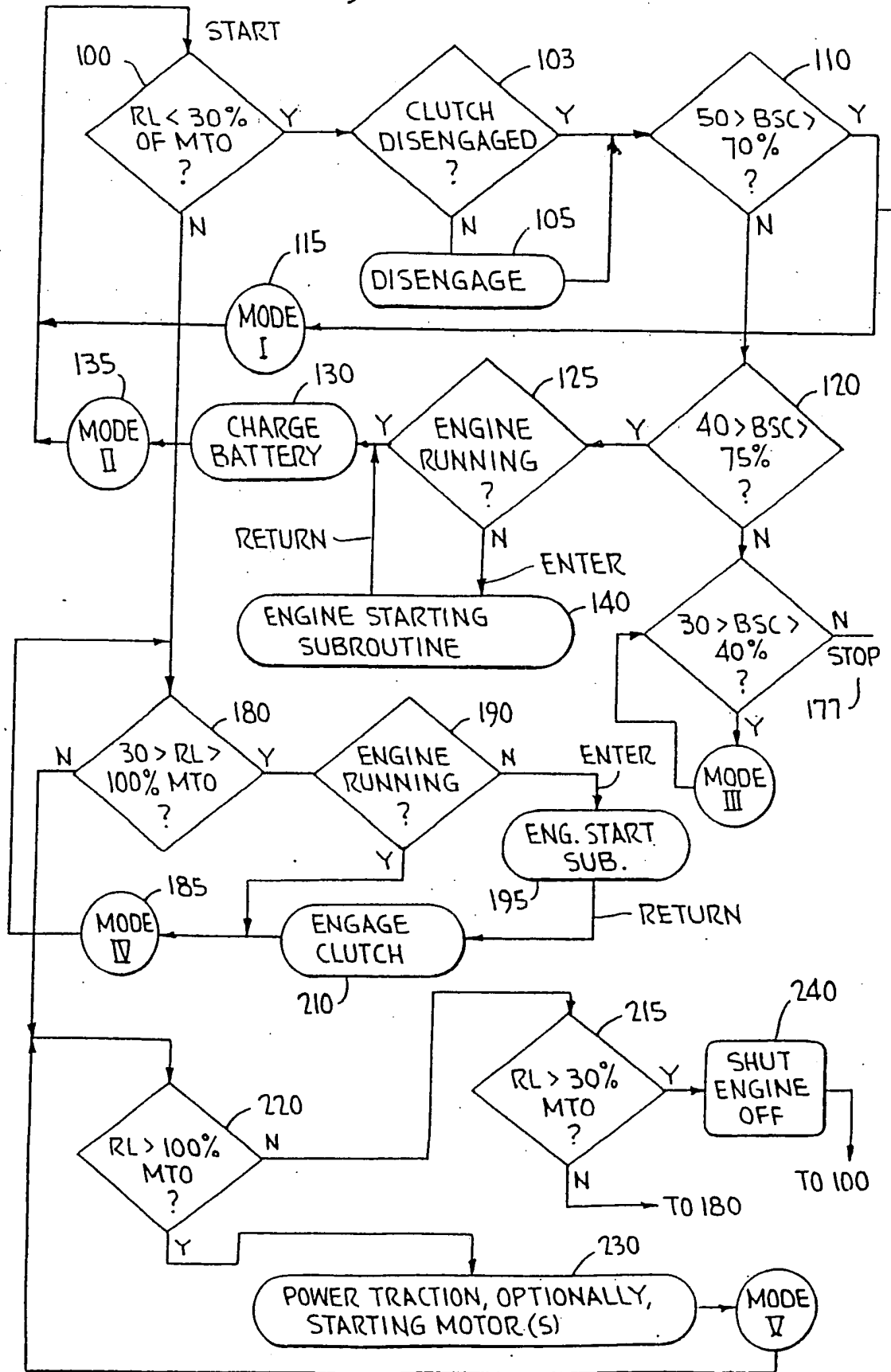

FIG. 9(a)  
ENGINE STARTING  
SUBROUTINE

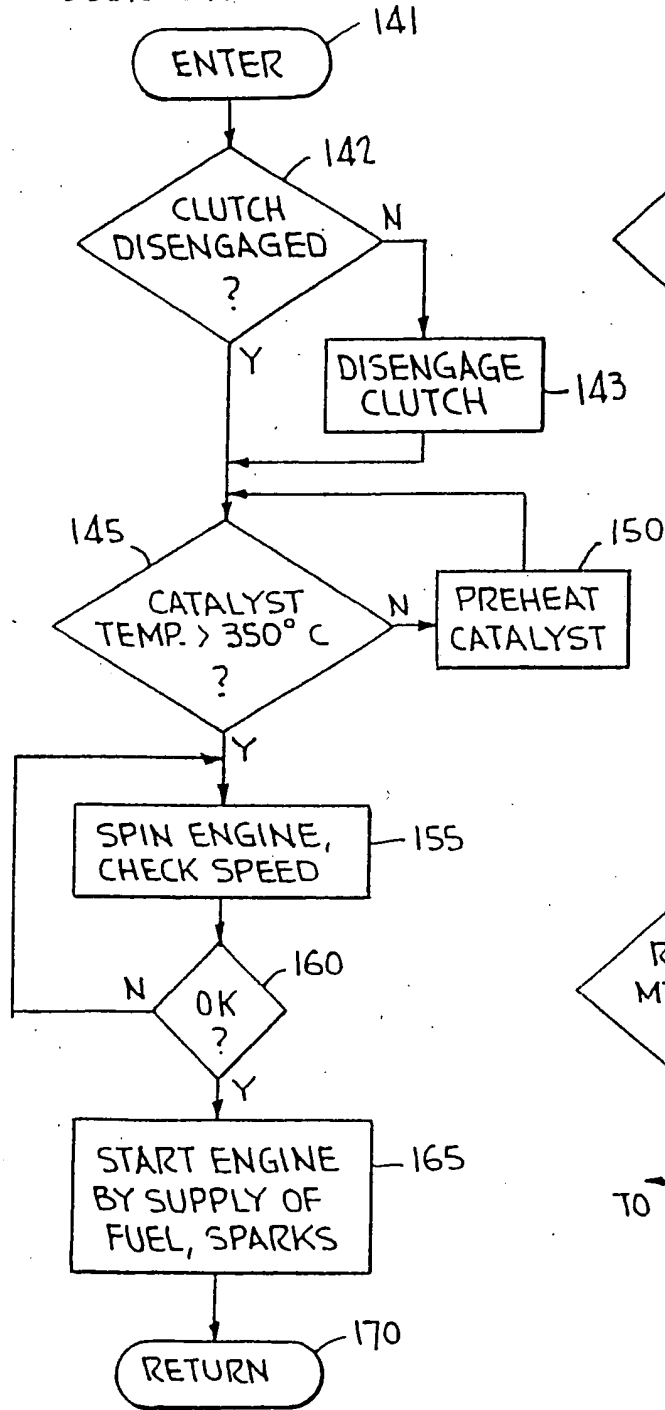

FIG. 9(b)

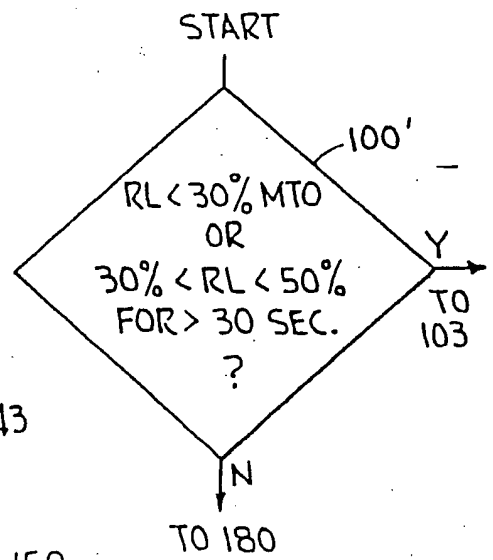
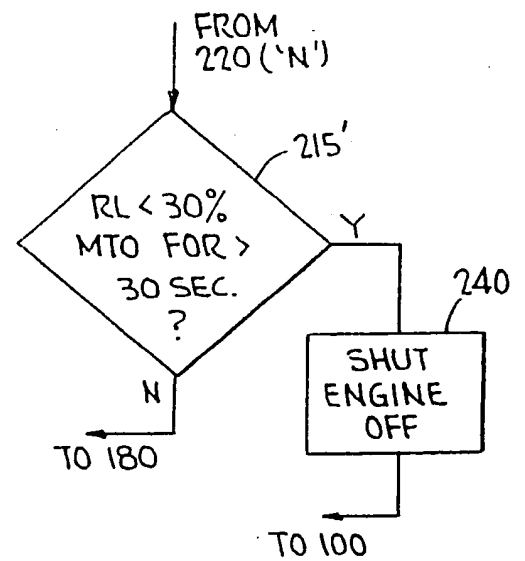

FIG. 9(c)





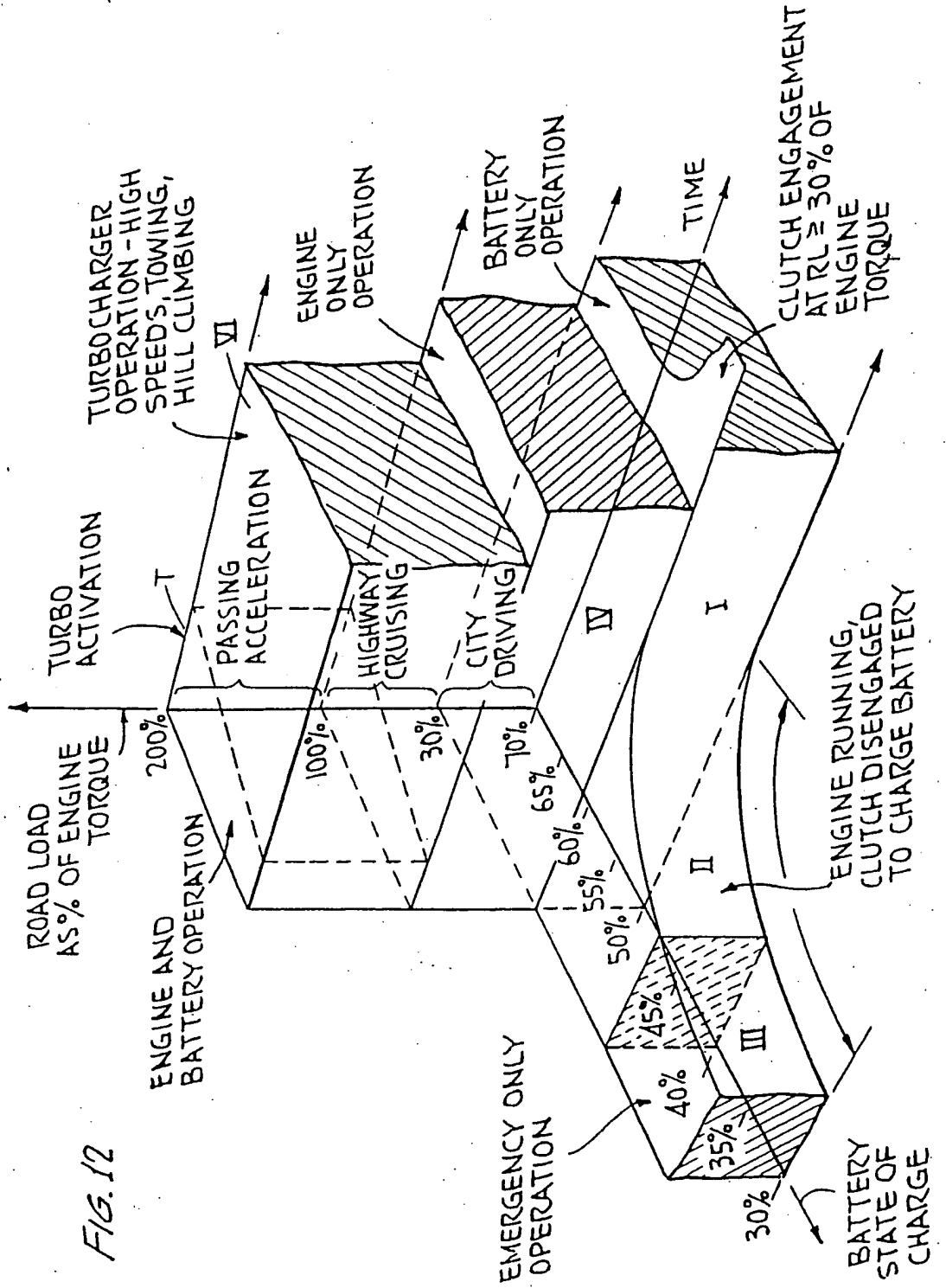

FIG. 12

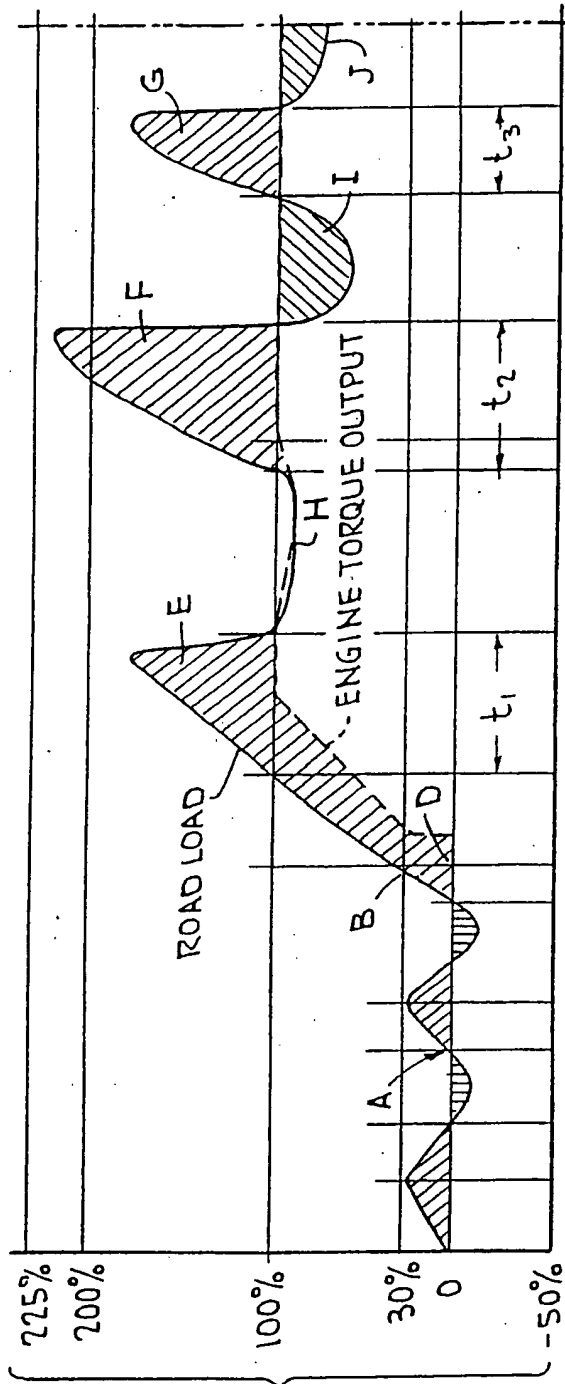

FIG. 13(a)  
ROAD LOAD AS %  
OF ENGINE'S MAX.  
TORQUE (NORMALLY  
ASPIRATED)

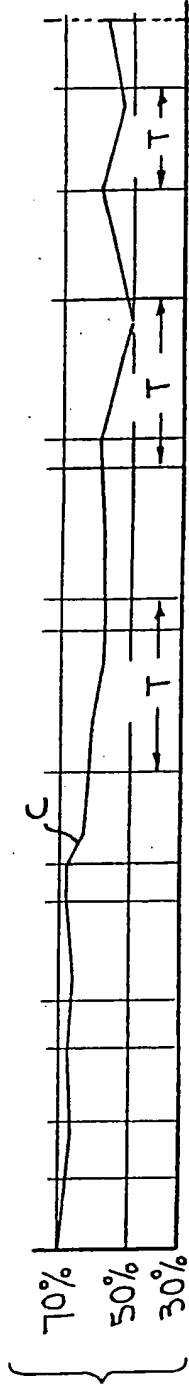

FIG. 13(b)  
BATTERY STATE  
OF CHARGE

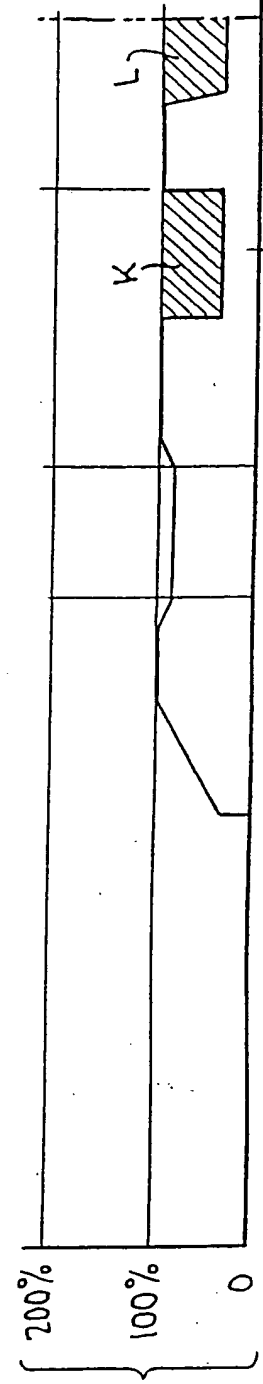

FIG. 13(c)  
ENGINE + TURBO-  
CHARGER OPERATION

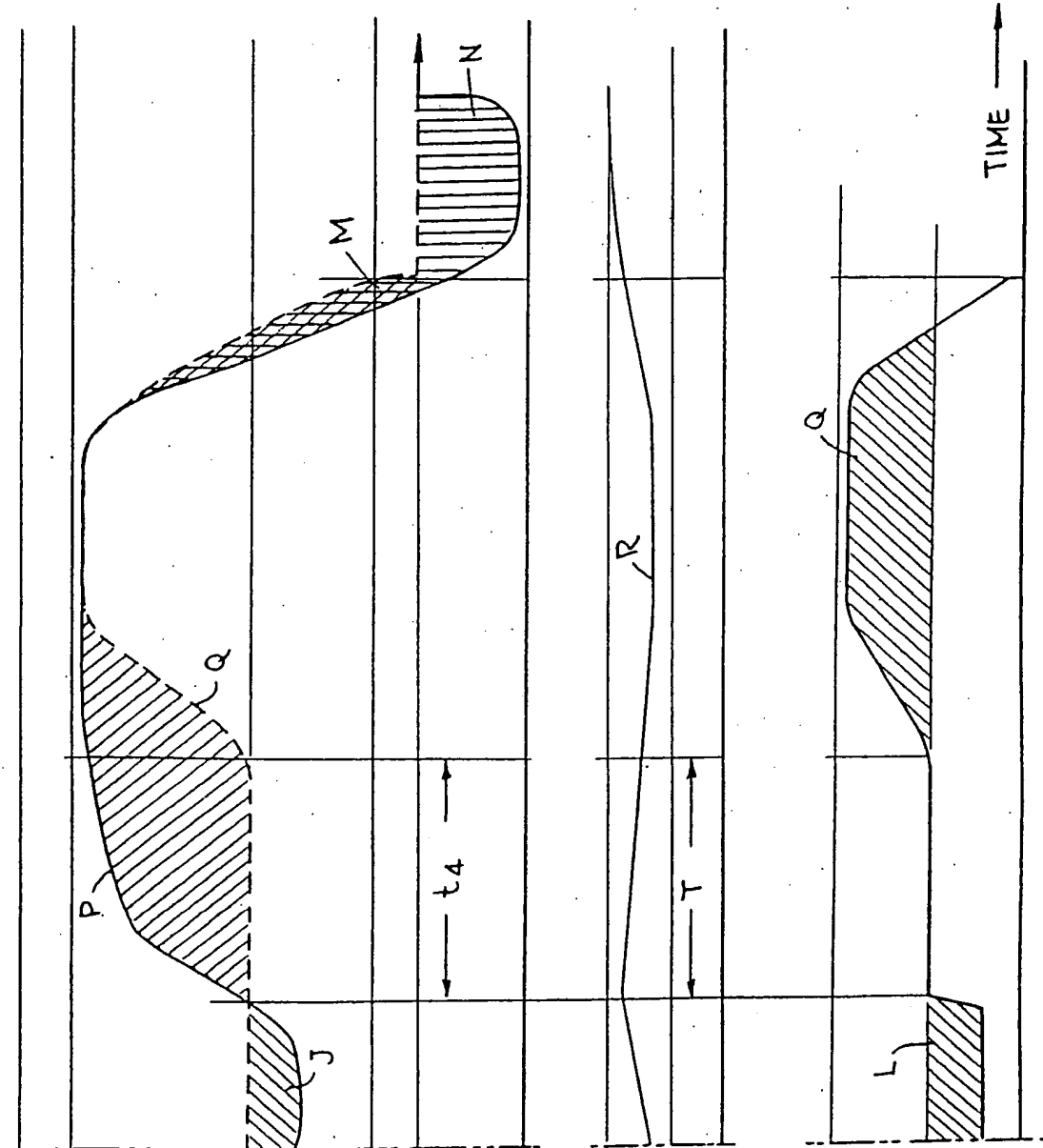

FIG. 13(a)  
(CONTINUED)

FIG. 13(b)  
(CONTINUED)

FIG. 13(c)  
(CONTINUED)







17/17

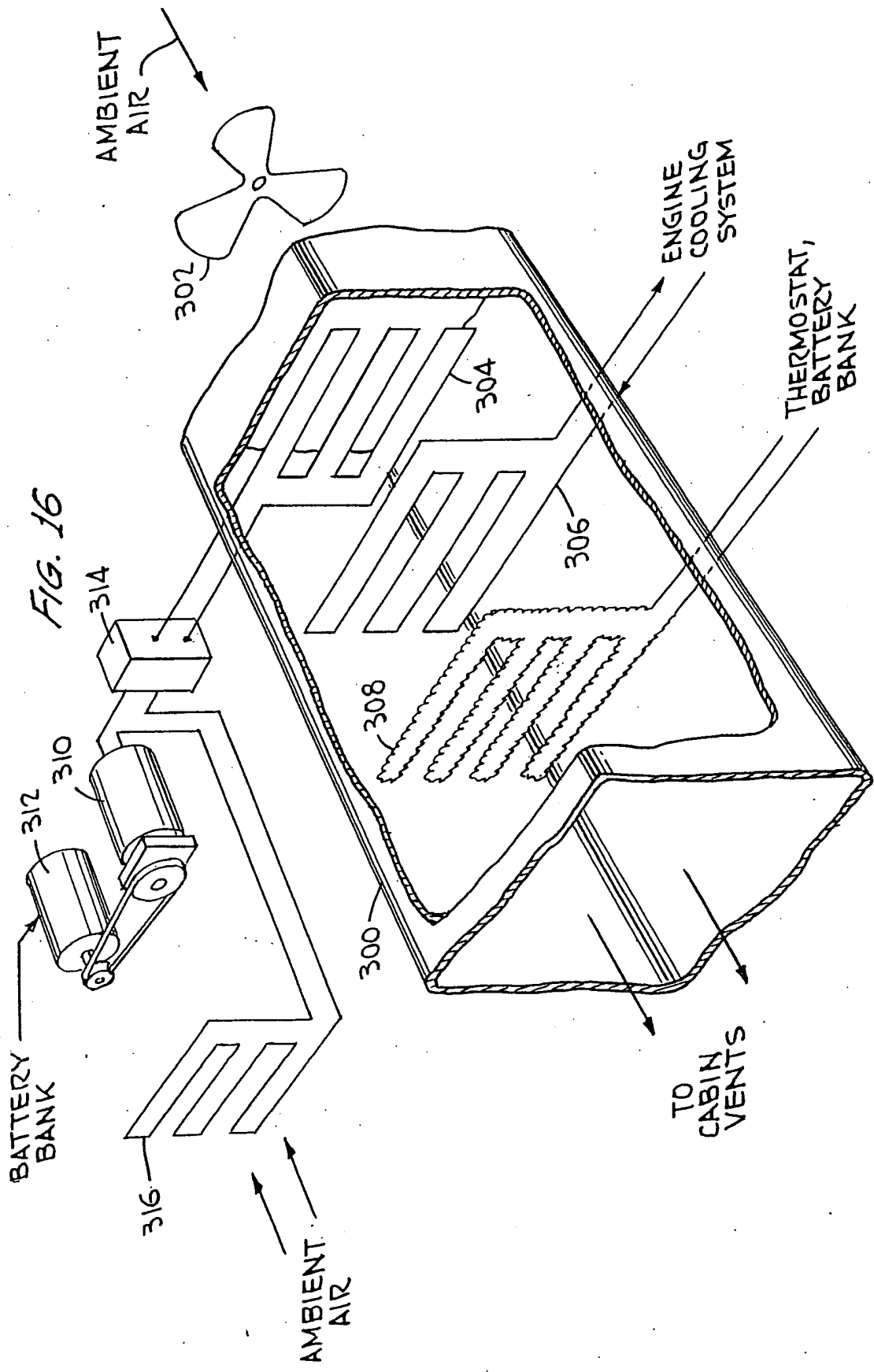

DECLARATION AND POWER OF ATTORNEY FOR PATENT APPLICATION

As a below named inventor, I hereby declare that:

My residence, post office address and citizenship are as stated next to my name.

I believe I am the original, first and sole inventor (if only one name is listed below) or an original, first and joint inventor (if plural names are listed below) of the subject matter which is claimed and for which a patent is sought on the invention entitled:

Hybrid Vehicles,

the specification of which

\_\_\_\_\_ is attached hereto

X was filed on April 2, 2001 now assigned Application Serial No. 09/822,866 and was amended on \_\_\_\_\_ (if applicable).

I hereby state that I have reviewed and understand the contents of the above identified application, including the specification and claims, as amended by any amendment referred to above.

I acknowledge the duty to disclose information which is material to the examination of this application in accordance with Title 37, Code of Federal Regulations, § 1.56(a).

I hereby claim foreign priority benefits under Title 35, United States Code, § 119, of the international application for patent or inventor's certificate listed below and have also identified below any foreign application for patent or inventor's certificate having a filing date before that of the application on which priority is claimed: NONE

Prior International Application(s)

Priority  
Claimed

(Number)	(Country)	(Day/Month/Yr. Filed)	Yes	No
----------	-----------	-----------------------	-----	----

I hereby claim the benefit under Title 35, United States Code, § 120 of any United States application listed below and, insofar as the subject matter of each of the claims of this application is not disclosed in the prior United States application in the manner provided by the first paragraph of Title 35, United States Code, § 112, I acknowledge the duty to disclose material information as defined in Title 37, Code of Federal Regulations, § 1.56(a) which occurred between the filing date of the prior application and the national or PCT international filing date of this application:

09/264,817	3/9/99	Issued (6,209,672)
60/100,095	9/14/98	Converted
09/392,743	9/9/99	Pending
60/122,296	3/1/99	Converted
(Application SN)	(Filing Date)	Status (patented, pending abandoned, converted)

POWER OF ATTORNEY: As a named inventor, I hereby appoint the following attorney to prosecute this application and transact all business in the Patent and Trademark Office connected therewith:

Michael de Angeli, Reg. No. 27,869

Send correspondence to: Michael de Angeli  
1901 Research Blvd.  
Suite 330  
Rockville, MD 20850

Direct Telephone Calls to: (301) 217-9585

I hereby declare that all statements made herein of my own knowledge are true and that all statements made on information and belief are believed to be true; and further that these statements were made with the knowledge that willful false statements and the like so made are punishable by fine or imprisonment, or both, under § 1001 of Title 18 of the United States Code and that such willful false statements may jeopardize the validity of the application or any patent issued thereon.

Full name of sole or first joint inventor: Alex J. Severinsky

Inventor's Signature Alex J. Severinsky Date 5/18/2001

Residence: Washington, DC Citizenship: US

Post Office Address: 4707 Foxhall Crescent, Washington, DC 20007

Full name of second joint inventor, if any: Theodore Louckes

Inventor's Signature Theodore Louckes Date 5/25/2001

Residence: Holly, MI Citizenship: US

Post Office Address: 10398 Appomatox, Holly, MI, 48442

**BEST AVAILABLE COPY**

IN THE UNITED STATES PATENT AND TRADEMARK OFFICE

In re the Patent Application of :  
Severinsky et al : Examiner: N/A  
Serial No.: N/A : Group Art Unit:  
Filed: Herewith : Att.Dkt:PAICE201.DIV.3  
For: Hybrid Vehicles :

Hon. Commissioner for Patents  
P.O. Box 1450  
Alexandria VA 22313-1450

PRELIMINARY AMENDMENT

Sir:

Prior to examination, kindly amend the above-identified application as follows:

Kindly amend the claims to appear as follows:

1 - 16 (canceled)

17. (new) A hybrid vehicle, comprising:

at least two wheels, operable to receive power to propel said hybrid vehicle;

a first alternating current (AC) electric motor, operable to provide power to said at least two wheels to propel said hybrid vehicle;

a second AC electric motor;

an engine coupled to said second electric motor, operable to provide power to said at least two wheels to propel the hybrid vehicle, and/or to said second electric motor to drive the second electric motor to generate electric power;

a first alternating current-direct current (AC-DC) converter having an AC side coupled to said first electric motor, operable to accept AC or DC current and convert the current to DC or AC current respectively;

a second AC-DC converter coupled to said second electric motor, at least operable to accept AC current and convert the current to DC;

an electrical storage device coupled to a DC side of said AC-DC converters, wherein the electrical storage device is operable to store DC energy received from said AC-DC converters and provide DC energy to at least said first AC-DC converter for providing power to at least said first electric motor; and

a controller, operable to start and stop the engine to minimize fuel consumption;

wherein a ratio of maximum DC voltage on the DC side of at least said first AC-DC converter coupled to said first electric motor to current supplied from said

electrical storage device to at least said first AC-DC converter, when maximum current is so supplied, is at least 2.5.

18. (new) The hybrid vehicle of claim 17, wherein both said AC-DC converters are capable of converting DC provided by said electrical storage device to AC, and wherein said maximum current is measured on one or more respective DC sides thereof.

19. (new) The hybrid vehicle of claim 17, wherein said ratio is more than 2.5 during supply of maximum power from said electrical storage device to at least said two wheels by said first electric motor.

20. (new) The hybrid vehicle of claim 17, wherein said ratio is at least 3.

21. (new) The hybrid vehicle of claim 17, wherein the maximum DC voltage is at least approximately 500 volts.

22. (new) The hybrid vehicle of claim 17, wherein the maximum current is less than approximately 150 amperes.

23. (new) The hybrid vehicle of claim 17, wherein said controller is further operable to:

start and stop said engine at any speed of said hybrid vehicle;

disable engine operation when vehicle load on said engine results in torque less than 20% of a maximum torque output (MTO) of said engine; and

enable engine operation at any required combination of its speed and its torque, except said condition of disabling operation.

24. (new) The hybrid vehicle of claim 23, wherein said controller is operable to stop said engine when said vehicle load on said engine results in torque lower than 30% of the MTO of the engine.

25. (new) The hybrid vehicle of claim 23, wherein said controller is operable to start and operate said engine when said vehicle load is sufficient to require said engine to produce torque at least equal to a setpoint (SP), and wherein said SP is substantially less than the MTO of said engine.

26. (new) The hybrid vehicle of claim 25, wherein said SP is at least 20% of the MTO of the engine.

27. (new) The hybrid vehicle of claim 25, wherein said SP is at least 30% of the MTO of the engine.

28. (new) The hybrid vehicle of claim 25, wherein said controller is operable to disable engine operation when the vehicle load results in torque below a second setpoint (SP2), wherein said SP2 is less than said SP.

29. (new) The hybrid vehicle of claim 25, wherein said second electric motor is sized so as to be able to accept said engine torque equal to at least said SP.

30. (new) The hybrid vehicle of claim 25, wherein said SP varies over said engine speed range.

31. (new) The hybrid vehicle of claim 25, wherein the controller is operable to start and operate the engine at torque output levels less than SP under abnormal and



transient conditions to satisfy drivability and/or safety considerations.

32. (new) The hybrid vehicle of claim 17, wherein a rate of change of torque output of said engine is limited to a threshold value, wherein when a rate of change of vehicle load exceeds said threshold value of the rate of change of torque output of the engine, said controller is operable to operate said first motor and/or said second motor to supply additional power to at least said two wheels to supply remaining required torque.

33. (new) The hybrid vehicle of claim 32, wherein said threshold value is no more than about 2% per revolution.

34. (new) The hybrid vehicle of claim 32, wherein said controller is operable to vary said threshold value with respect to a state of charge of said electrical storage device.

35. (new) The hybrid vehicle of claim 17, wherein a maximum torque on at least said two wheels produced by said first electric motor or both electric motors is larger than a maximum torque on at least said two wheels produced by said engine.

36. (new) The hybrid vehicle of claim 17, wherein a maximum rotational speed of said first electric motor is at least 50% larger than a maximum rotational speed of said engine.

37. (new) The hybrid vehicle of claim 17, further comprising:

a third AC electric motor;

wherein said first AC electric motor is coupled to a first pair of wheels to provide power to said first pair of wheels to propel said hybrid vehicle, and said third AC electric motor coupled to a second pair of wheels to provide power to said second pair of wheels to propel said hybrid vehicle.

38. (new) The hybrid vehicle of claim 37, wherein relative amounts of power directed to said first and second pairs of wheels by the first and third electric motors, respectively, is controlled by said controller.

39. (new) The hybrid vehicle of claim 37, wherein a torque range-broadening transmission is interposed between said engine and said at least said two wheels to which said engine is operable to provide power.

40. (new) The hybrid vehicle of claim 37, wherein a maximum torque provided to said first and second pairs of two wheels by said first and third electric motors, or by said first and third electric motors and said second electric motor, is larger than a maximum torque on at least said two wheels produced by said engine.

41. (new) The hybrid vehicle of claim 37, wherein a maximum rotational speed of said first electric motor is at least 50% larger than a maximum rotational speed of said engine.

42. (new) The hybrid vehicle of claim 17, wherein said engine comprises a turbocharger operable to increase the maximum torque output by said engine, and wherein said turbocharger is so operated when the power required of said engine exceeds a predetermined value for at least a

predetermined period of time.

43. (new) The hybrid vehicle of claim 17, wherein said engine is preheated prior to starting.

44. (new) The hybrid vehicle of claim 17, wherein said controller is further operable to:

start and stop said engine at any speed of said hybrid vehicle;

disable engine operation when vehicle load on said engine results in torque less than 20% of a maximum torque output (MTO) of said engine; and

enable engine operation at any required combination of its speed and its torque, except said condition of disabling operation, and

wherein a rate of change of torque output of said engine is limited to a threshold value, wherein when a rate of change of the vehicle load exceeds said threshold value of the rate of change of torque output of the engine, said controller is operable to operate said first motor and/or said second motor to supply additional power to at least said two wheels to supply remaining required torque.

45. (new) The hybrid vehicle of claim 17, wherein said controller is further operable to:

start and stop said engine at any speed of said hybrid vehicle;

disable engine operation when vehicle load on said engine results in torque less than 20% of a maximum torque output (MTO) of said engine; and

enable engine operation at any required combination of its speed and its torque, except said condition of disabling operation;

wherein said hybrid vehicle further comprises a third

AC electric motor; and

wherein said first AC electric motor is coupled to a first pair of wheels to provide power to said first pair of wheels to propel said hybrid vehicle, and said third AC electric motor is is coupled to a second pair of wheels to provide power to said second pair of wheels to propel said hybrid vehicle.

46. (new) The hybrid vehicle of claim 17, wherein said controller is further operable to:

start and stop said engine at any speed of said hybrid vehicle;

disable engine operation when vehicle load on said engine results in torque less than 20% of a maximum torque output (MTO) of said engine; and

enable engine operation at any required combination of its speed and its torque, except said condition of disabling operation;

wherein said engine comprises a turbocharger operable to increase the maximum torque output by said engine, and wherein said turbocharger is so operated when the power required of said engine exceeds a predetermined value for at least a predetermined period of time.

47. (new) The hybrid vehicle of claim 17, further comprising:

a third AC electric motor;

wherein said first AC electric motor is coupled to a first pair of wheels to provide power to said first pair of wheels to propel said hybrid vehicle, and said third AC electric motor is coupled to a second pair of wheels to provide power to said second pair of wheels to propel said hybrid vehicle, and

wherein a rate of change of torque output of said

engine is limited to a threshold value, wherein when a rate of change of vehicle load exceeds said threshold value of the rate of change of torque output of the engine, said controller is operable to operate said first motor and/or said second and/or third motors to supply additional power to at least said two wheels to supply remaining required torque.

48. (new) The hybrid vehicle of claim 17,

wherein a rate of change of torque output of said engine is limited to a threshold value, wherein when a rate of change of vehicle load exceeds said threshold value of the rate of change of torque output of the engine, said controller is operable to operate said first motor and/or said second and/or third motors to supply additional power to at least said two wheels to remaining required torque; and

wherein said engine comprises a turbocharger operable to increase the maximum torque output by said engine, and wherein said turbocharger is so operated when the power required of said engine exceeds a predetermined value for at least a predetermined period of time.

49. (new) The hybrid vehicle of claim 17, further comprising:

a third AC electric motor;

wherein said first alternating current (AC) electric motor is coupled to a first pair of wheels to provide power to said first pair of wheels to propel said hybrid vehicle, and a said third AC electric motor is provided and is coupled to a second pair of wheels to provide power to said second pair of wheels to propel said hybrid vehicle; and

wherein said engine comprises a turbocharger operable

to increase the maximum torque output by said engine, and wherein said turbocharger is so operated when the power required of said engine exceeds a predetermined value for at least a predetermined period of time.

50. (new) The hybrid vehicle of claim 17, further comprising:

a third AC electric motor;

wherein said first alternating current (AC) electric motor is coupled to a first pair of wheels to provide power to said first pair of wheels to propel said hybrid vehicle, and a said third AC electric motor is provided and is coupled to a second pair of wheels to provide power to said second pair of wheels to propel said hybrid vehicle; and

wherein a rate of change of torque output of said engine is limited to a threshold value, wherein when a rate of change of vehicle load exceeds said threshold value of the rate of change of torque output of the engine, said controller is operable to operate said first motor and/or said second motor to supply additional power to at least said two wheels to supply remaining required torque; and

wherein said controller is further operable to:

start and stop said engine at any speed of said hybrid vehicle;

disable engine operation when the vehicle load on said engine results in torque less than 20% of a maximum torque output (MTO) of said engine; and

enable engine operation at any required combination of its speed and its torque, except said condition of disabling operation.

51. (new) The hybrid vehicle of claim 17,

wherein a rate of change of torque output of said engine is limited to a threshold value, wherein when a rate of change of vehicle load exceeds said threshold value of the rate of change of torque output of the engine, said controller is operable to operate said first motor and/or said second motor to supply additional power to at least said two wheels to supply remaining required torque;

wherein said controller is further operable to:

start and stop said engine at any speed of said hybrid vehicle;

disable engine operation when the vehicle load on said engine results in torque less than 20% of a maximum torque output (MTO) of said engine; and

enable engine operation at any required combination of its speed and its torque, except said condition of disabling operation; and

wherein said engine comprises a turbocharger operable to increase the maximum torque output by said engine, and wherein said turbocharger is so operated when the power required of said engine exceeds a predetermined value for at least a predetermined period of time.

52. (new) The hybrid vehicle of claim 17, further comprising:

a third AC electric motor;

wherein said first alternating current (AC) electric motor is coupled to a first pair of wheels to provide power to said first pair of wheels to propel said hybrid vehicle, and a said third AC electric motor is provided and is coupled to a second pair of wheels to provide power to said second pair of wheels to propel said hybrid vehicle;

wherein a rate of change of torque output of said engine is limited to a threshold value, wherein when a rate

of change of vehicle load exceeds said threshold value of the rate of change of torque output of the engine, said controller is operable to operate said first motor and/or said second motor to supply additional power to at least said two wheels to supply remaining required torque; and

wherein said engine comprises a turbocharger operable to increase the maximum torque output by said engine, and wherein said turbocharger is so operated when the power required of said engine exceeds a predetermined value for at least a predetermined period of time.

53. (new) The hybrid vehicle of claim 17, further comprising:

a third AC electric motor;

wherein said first alternating current (AC) electric motor is coupled to a first pair of wheels to provide power to said first pair of wheels to propel said hybrid vehicle, and a said third AC electric motor is provided and is coupled to a second pair of wheels to provide power to said second pair of wheels to propel said hybrid vehicle;

wherein said controller is further operable to:

start and stop said engine at any speed of said hybrid vehicle;

disable engine operation when vehicle load on said engine results in torque less than 20% of a maximum torque output (MTO) of said engine; and

enable engine operation at any required combination of its speed and its torque, except said condition of disabling operation; and

wherein said engine comprises a turbocharger operable to increase the maximum torque output by said engine, and wherein said turbocharger is so operated when the power required of said engine exceeds a predetermined value for at least a predetermined period of time.



54. (new) The hybrid vehicle of claim 17, further comprising:

a third AC electric motor;

wherein said first alternating current (AC) electric motor is coupled to a first pair of wheels to provide power to said first pair of wheels to propel said hybrid vehicle, and a said third AC electric motor is provided and is coupled to a second pair of wheels to provide power to said second pair of wheels to propel said hybrid vehicle;

wherein said controller is further operable to:

start and stop said engine at any speed of said hybrid vehicle;

disable engine operation when vehicle load on said engine results in torque less than 20% of a maximum torque output (MTO) of said engine; and

enable engine operation at any required combination of its speed and its torque, except said condition of disabling operation;

wherein a rate of change of torque output of said engine is limited to a threshold value, wherein when a rate of change of the vehicle load exceeds said threshold value of the rate of change of torque output of the engine, said controller is operable to operate said first motor and/or said second motor to supply additional power to at least said two wheels to supply remaining required torque; and

wherein said engine comprises a turbocharger operable to increase the maximum torque output by said engine, and wherein said turbocharger is so operated when the power required of said engine exceeds a predetermined value for at least a predetermined period of time.

55. (new) The hybrid vehicle of claim 17, wherein said controller is further operable to:

start and stop said engine at any speed of said

hybrid vehicle;

disable engine operation when road load on said engine results in torque less than 20% of a maximum torque output (MTO) of said engine; and

enable engine operation at any required combination of its speed and its torque, except said condition of disabling operation.

56. (new) The hybrid vehicle of claim 17, wherein a rate of change of torque output of said engine is limited to a threshold value, wherein when a rate of change of road load exceeds said threshold value of the rate of change of torque output of the engine, said controller is operable to operate said first motor and/or said second motor to supply additional power to at least said two wheels to supply remaining required torque.

57. (new) A method of control of a hybrid vehicle, said hybrid vehicle comprising:

at least two wheels, operable to receive power to propel said hybrid vehicle;

a first alternating current (AC) electric motor, operable to provide power to said at least two wheels to propel said hybrid vehicle;

a second AC electric motor;

an engine coupled to said second electric motor, operable to provide power to said at least two wheels to propel the hybrid vehicle, and/or to said second electric motor to drive the second electric motor to generate electric power;

a first alternating current-direct current (AC-DC) converter having an AC side coupled to said first electric motor, operable to accept AC or DC current and convert the current to DC or AC current respectively;

a second AC-DC converter coupled to said second electric motor, at least operable to accept AC current and convert the current to DC;

an electrical storage device coupled to a DC side of said AC-DC converters, wherein the electrical storage device is operable to store DC energy received from said AC-DC converters and provide DC energy to at least said first AC-DC converter for providing power to at least said first electric motor; and

a controller, operable to start and stop the engine to minimize fuel consumption;

said method comprising the step of controlling flow of DC current such that a ratio of maximum DC voltage on the DC side of at least said first AC-DC converter coupled to said first electric motor to current supplied from said electrical storage device to at least said first AC-DC converter, when maximum current is so supplied, is at least 2.5.

58. (new) The method of claim 57, wherein said ratio is more than 2.5 during supply of maximum power from said electrical storage device to at least said two wheels by said first electric motor.

59. (new) The method of claim 57, wherein the maximum DC voltage is at least approximately 500 volts.

60. (new) The method of claim 57, wherein the maximum current is less than approximately 150 amperes.

61. (new) The method of claim 57, wherein said controller performs the following additional steps:

starts and stops said engine at any speed of said hybrid vehicle;

disables engine operation when vehicle load on said engine results in torque less than 20% of a maximum torque output (MTO) of said engine; and

enables engine operation at any required combination of its speed and its torque, except said condition of disabling operation.

62. (new) The method of claim 61, wherein said controller stops said engine when said vehicle load on said engine results in torque lower than 30% of the MTO of the engine.

63. (new) The method of claim 61, wherein said controller starts and operates said engine when said vehicle load is sufficient to require said engine to produce torque at least equal to a setpoint (SP), and wherein said SP is substantially less than the MTO of said engine.

64. (new) The method of claim 63, wherein said SP is at least 20% of the MTO of the engine.

65. (new) The method of claim 63, wherein said SP is at least 30% of the MTO of the engine.

66. (new) The method of claim 63, wherein said controller disables engine operation when the vehicle load results in torque below a second setpoint (SP2), wherein said SP2 is less than said SP.

67. (new) The method of claim 63, wherein said SP varies over said engine speed range.

68. (new) The method of claim 63, wherein the controller is operable to start and operate the engine at torque output levels less than SP under abnormal and transient conditions

to satisfy drivability and/or safety considerations.

69. (new) The method of claim 57, wherein a rate of change of torque output of said engine is limited to a threshold value, wherein when a rate of change of vehicle load exceeds said threshold value of the rate of change of torque output of the engine, said controller is operable to operate said first motor and/or said second motor to supply additional power to at least said two wheels to supply remaining required torque.

70. (new) The method of claim 69, wherein said threshold value is no more than about 2% per revolution.

71. (new) The method of claim 69, wherein said controller is operable to vary said threshold value with respect to a state of charge of said electrical storage device.

72. (new) The method of claim 57, wherein said engine comprises a turbocharger operable to increase the maximum torque output by said engine, and wherein said method comprises the further step of operating said turbocharger when the power required of said engine exceeds a predetermined value for at least a predetermined period of time.

73. (new) The method of claim 57, comprising the further step of preheating said engine prior to starting.

74. (new) A method for controlling a hybrid vehicle, comprising:

operating a first alternating current (AC) electric motor comprised in the hybrid vehicle to propel the hybrid vehicle, comprising:

providing direct current (DC) from an electrical storage device to a DC side of a first alternating current-direct current (AC-DC) converter;

the first AC-DC converter converting the DC current to AC current;

providing the AC current to the first AC electric motor to drive the AC electric motor; and

providing power to at least two wheels of the hybrid vehicle;

starting and operating an engine comprised in the hybrid vehicle to propel the vehicle and/or drive a second AC electric motor comprised in the hybrid vehicle to generate electric power, comprising providing power to the at least two wheels and/or the second AC electric motor respectively;

converting the generated electric power from AC to DC using a second AC-DC converter; and

storing the converted electric power in the electrical storage device, wherein the electrical storage device is coupled to a DC side of the second AC-DC converter;

wherein a ratio of maximum DC voltage on the DC side of at least said first AC-DC converter coupled to the first electric motor to current supplied from the electrical storage device to at least the first AC-DC converter, when maximum current is so supplied, is at least 2.5.

75. (new) The method of claim 74, further comprising:

disabling engine operation when vehicle load on the engine results in torque less than 20% of a maximum torque output (MTO) of the engine;

wherein said starting and operating the engine comprises starting and operating the engine at any required combination of its speed and its torque, except when the vehicle load on the engine results in torque less than 20%

of the MTO of the engine;

wherein said disabling and said starting and operating occurs independently of speed of the hybrid vehicle.

76. (new) The method of claim 74, further comprising:

limiting a rate of change of torque output of the engine to a threshold value; and

operating the first and/or the second AC electric motors to supply additional power to the at least two wheels to supply remaining required torque when a rate of change of vehicle load exceeds the threshold value of the rate of change of torque output of the engine.

77. (new) The method of claim 74, further comprising:

operating a third AC electric motor to provide power to the at least two wheels of the hybrid vehicle to propel the hybrid vehicle;

wherein said providing power to the at least two wheels comprised in said operating the first AC electric motor comprises providing power to a first pair of wheels of the at least two wheels, and wherein said operating the third AC electric motor comprises providing power to a second pair of wheels of the at least two wheels.

78. (new) The method of claim 74, further comprising:

operating a turbocharger comprised by the engine of the hybrid vehicle to increase maximum torque output (MTO) produced by the engine when torque required of the engine exceeds a predetermined value for at least a predetermined period of time.

**REMARKS**

The above new claims are presented to ensure proper scope to the protection of the invention. No new matter is included. Entry and favorable consideration are respectfully requested.

Respectfully submitted,

Dated: May 5, 2006



Michael de Angeli  
Reg. No. 27,869  
60 Intrepid Lane  
Jamestown, RI 02835  
401-423-3190



1 / 17

FIG. 1  
(PRIOR ART)

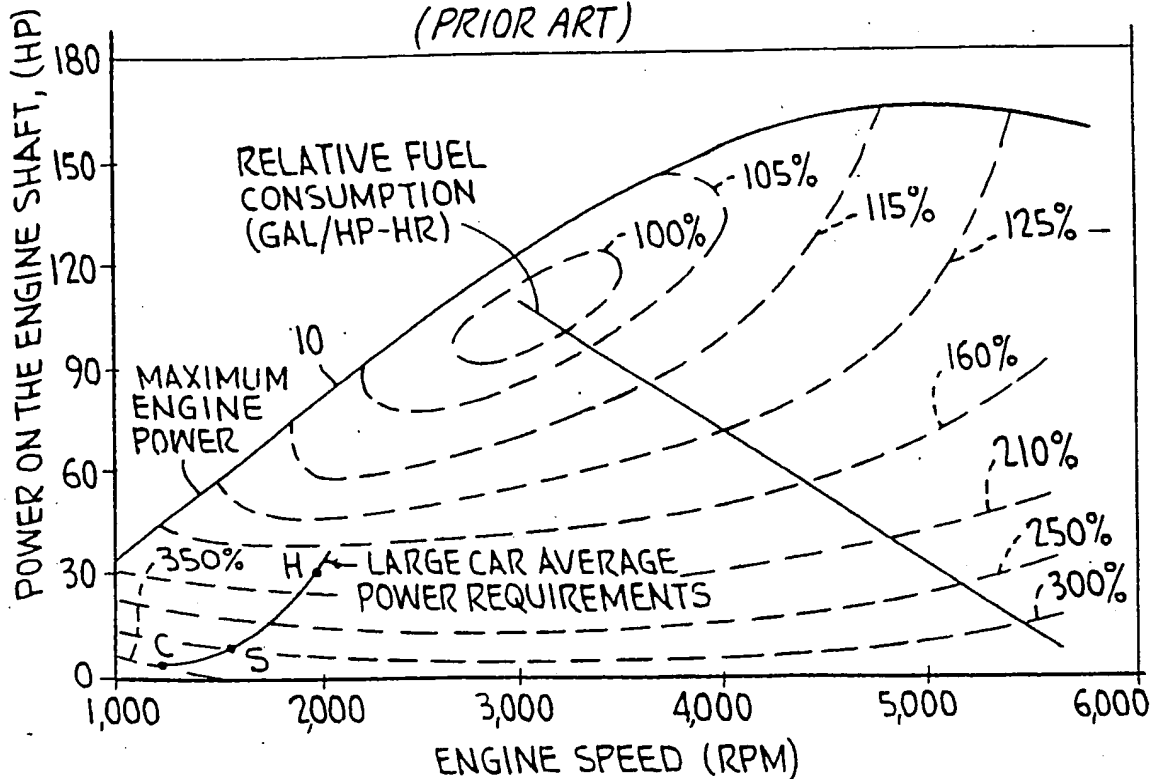
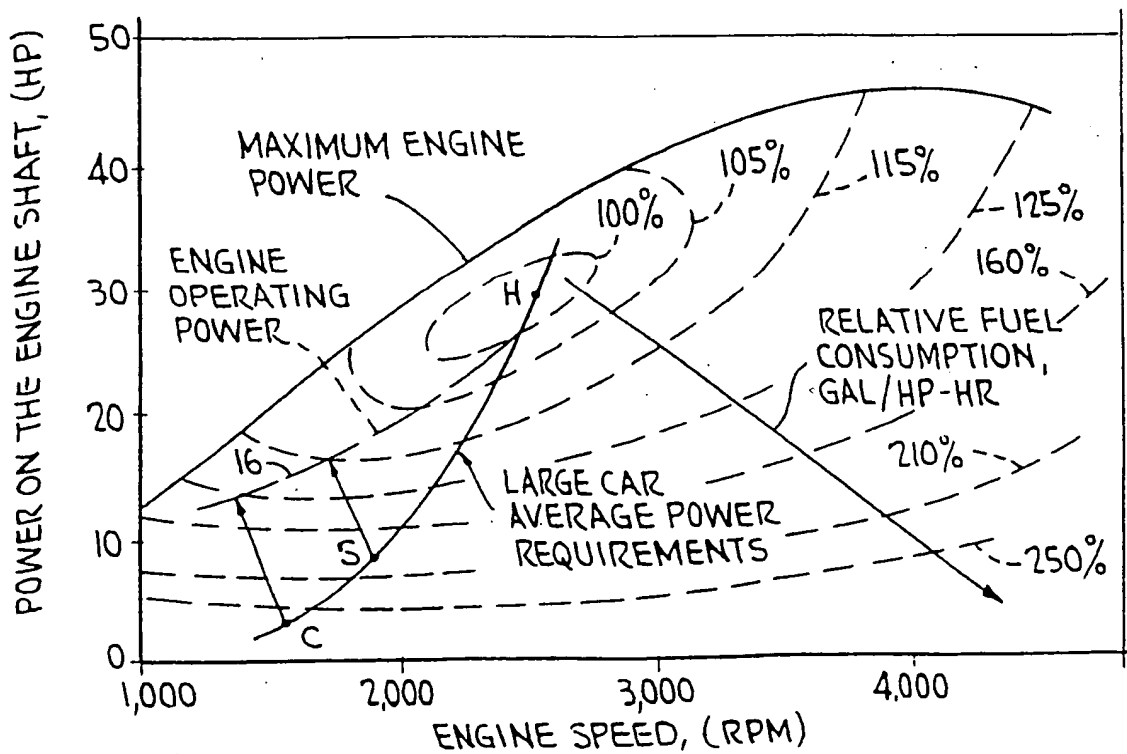

FIG. 2



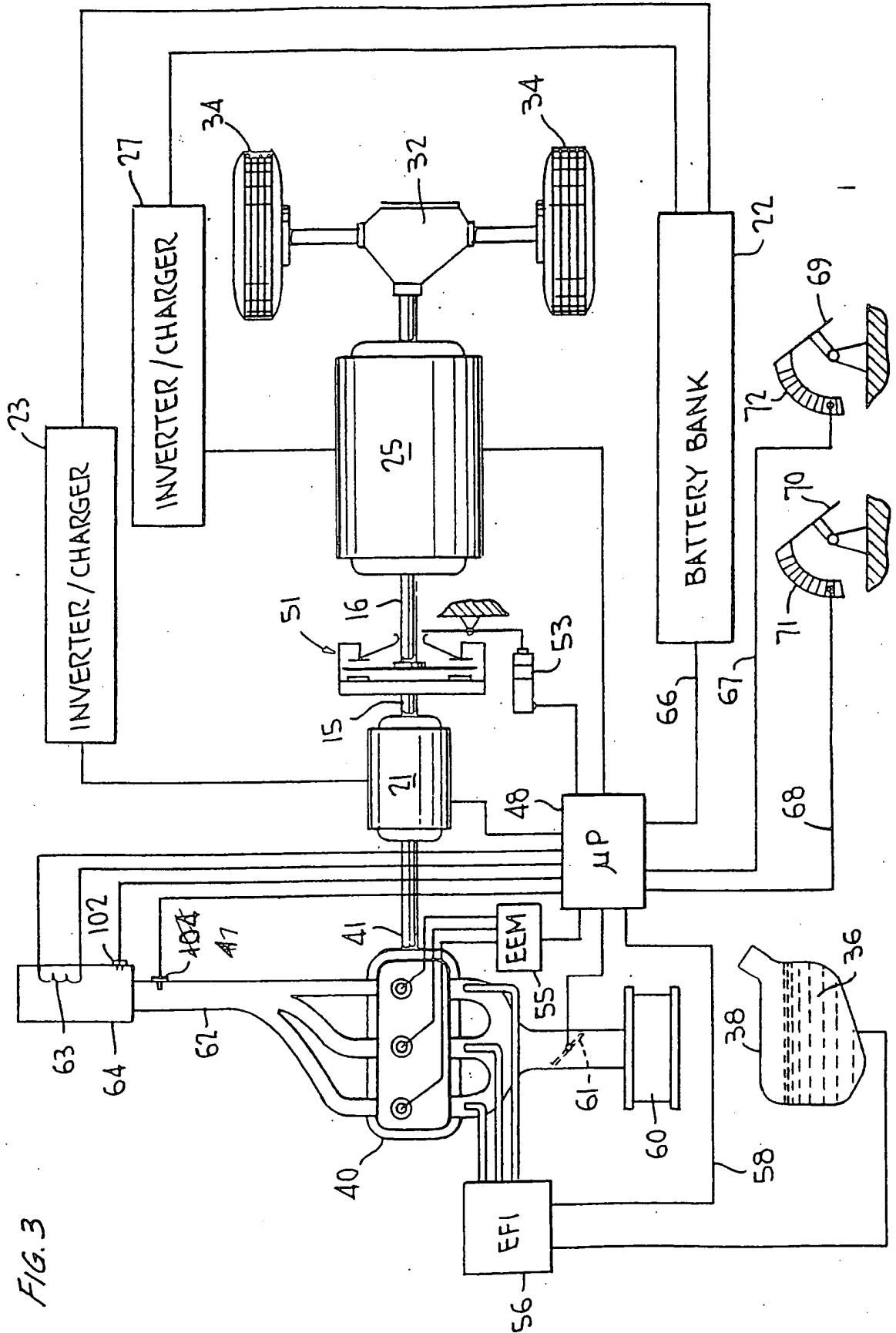

FIG. 3

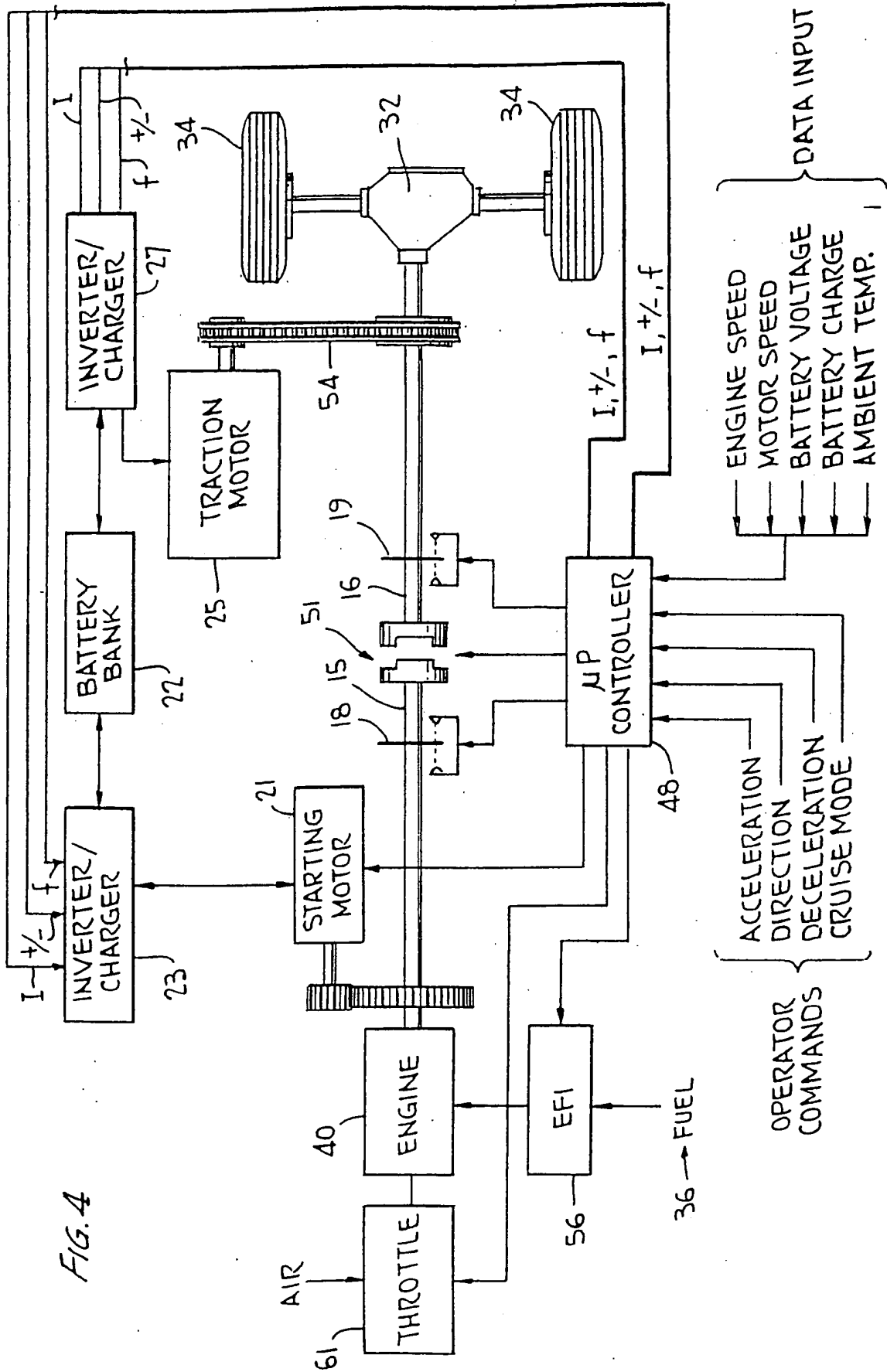

FIG. 4

SUBSTITUTE SHEET (RULE 26)

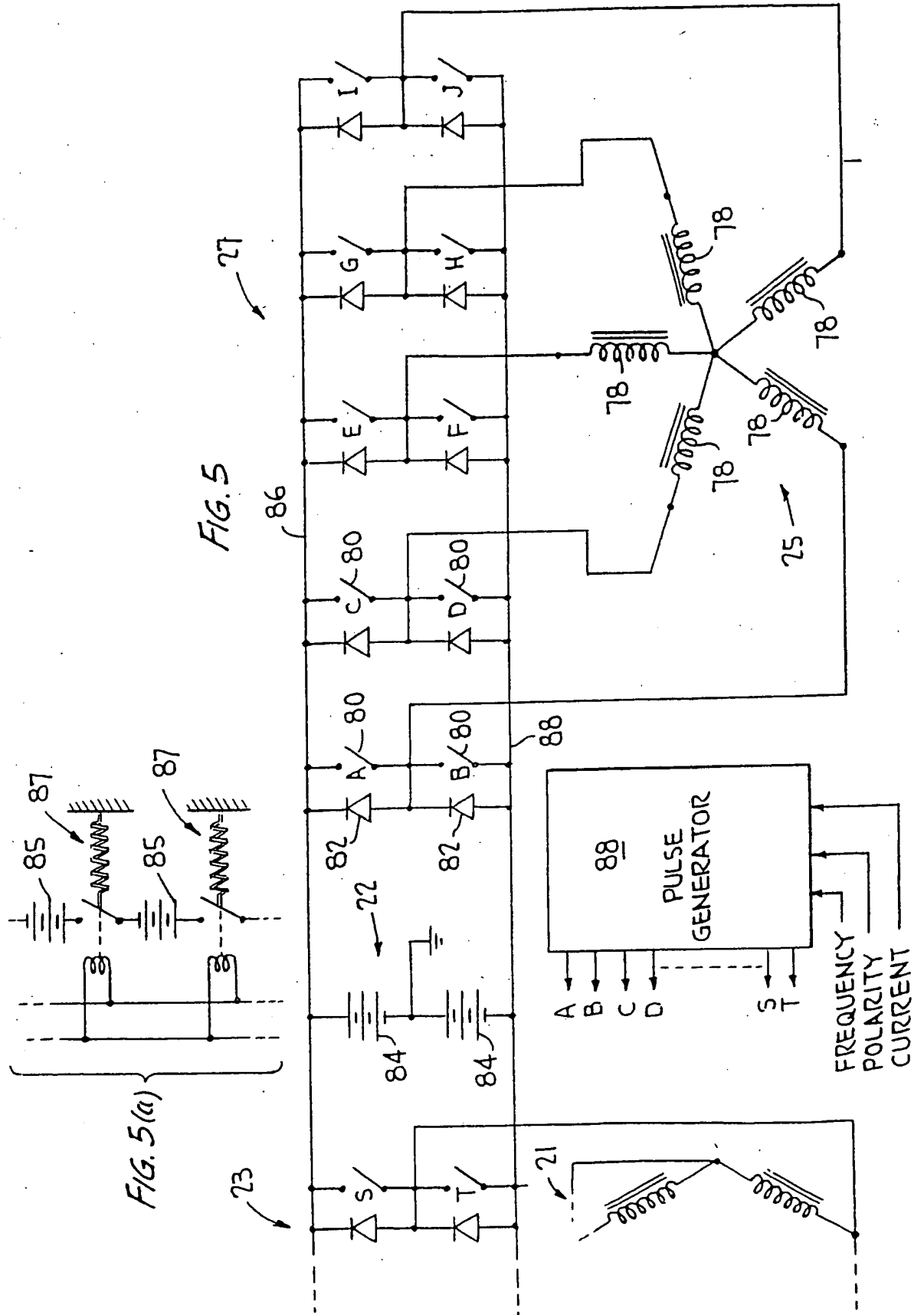

FIG. 5(a)

FIG. 5

SUBSTITUTE SHEET (RULE 26)

FIG. 6

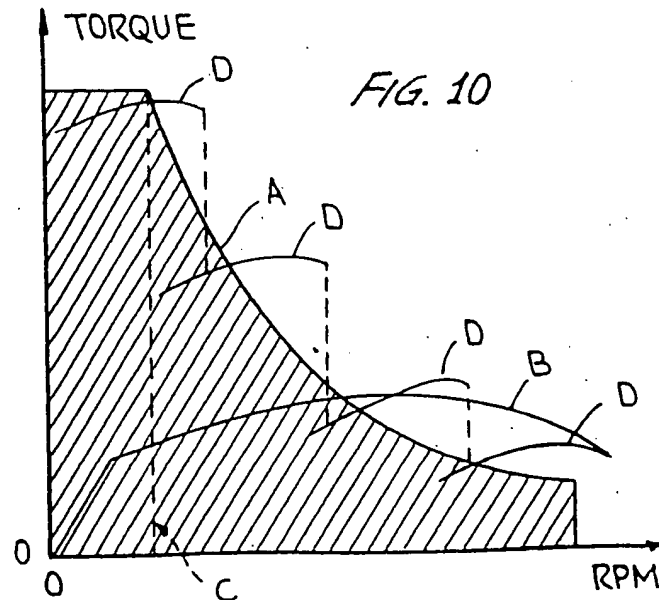
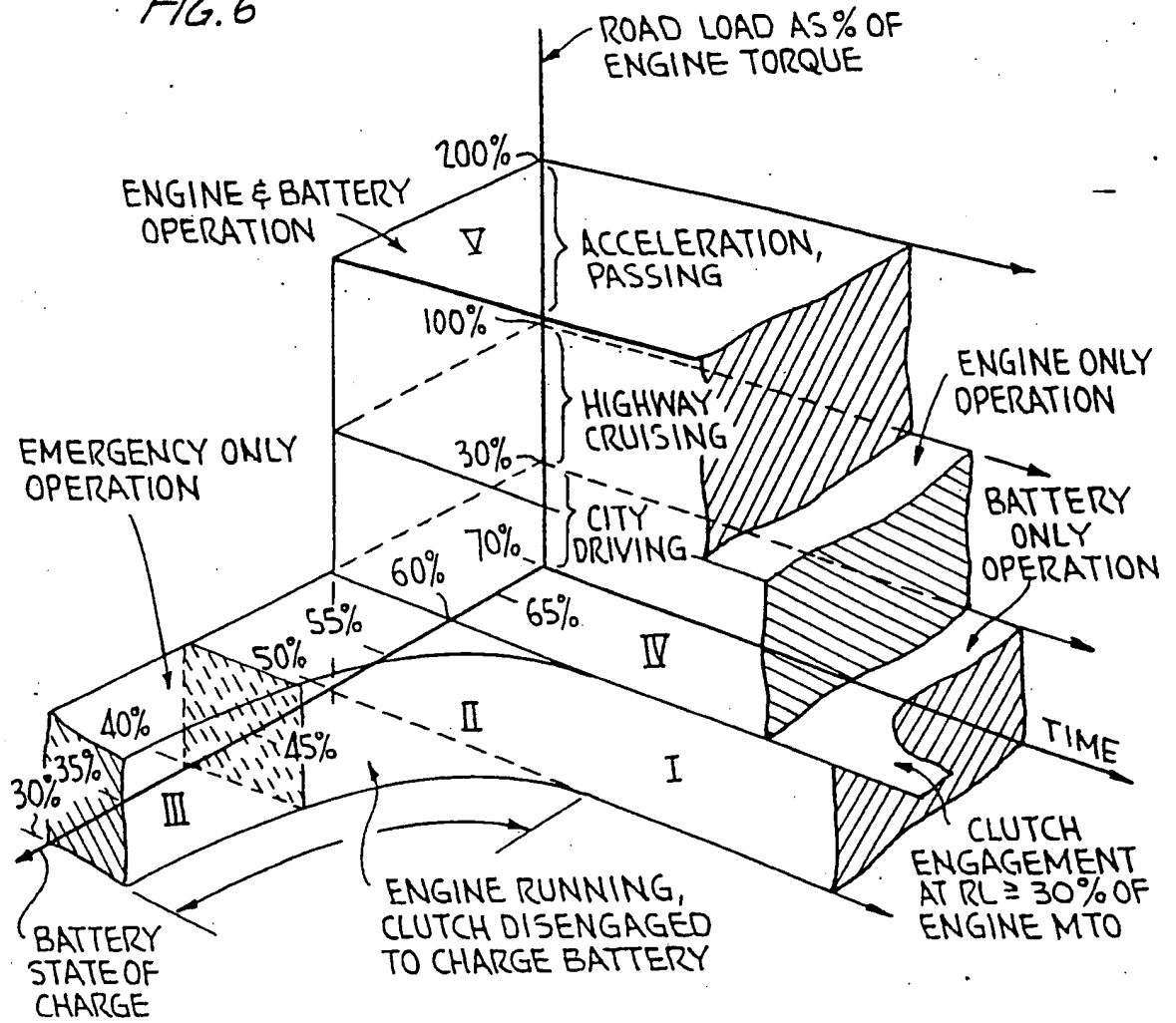

FIG. 10

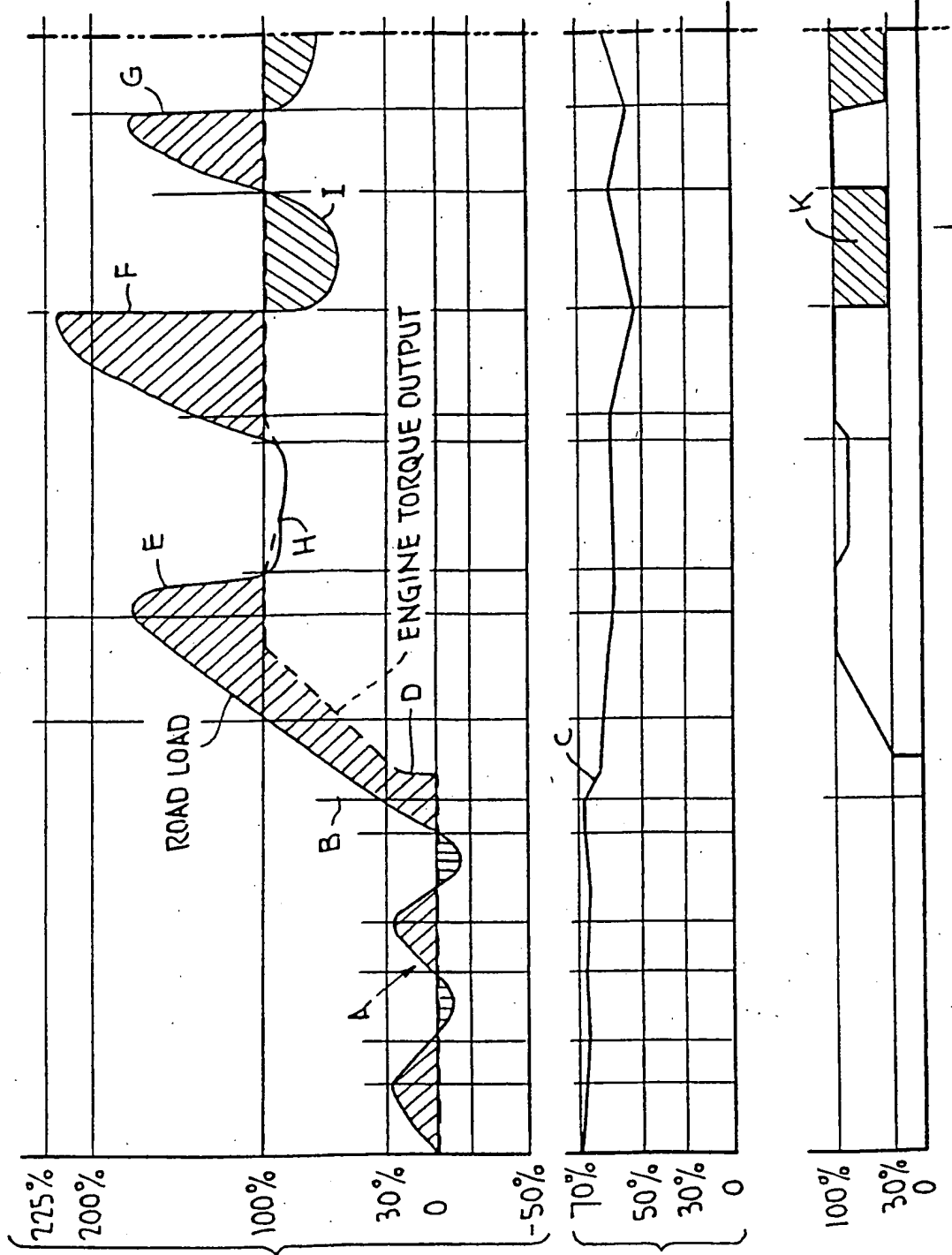

FIG. 7(a)  
ROAD LOAD AS %  
OF MAX. ENGINE  
TORQUE OUTPUT  
(% MTO)

FIG. 7(b)  
BATTERY BANK  
STATE OF CHARGE  
(BSC)

FIG. 7(c)  
ENGINE TORQUE  
OUTPUT

SUBSTITUTE SHEET (RULE 26)

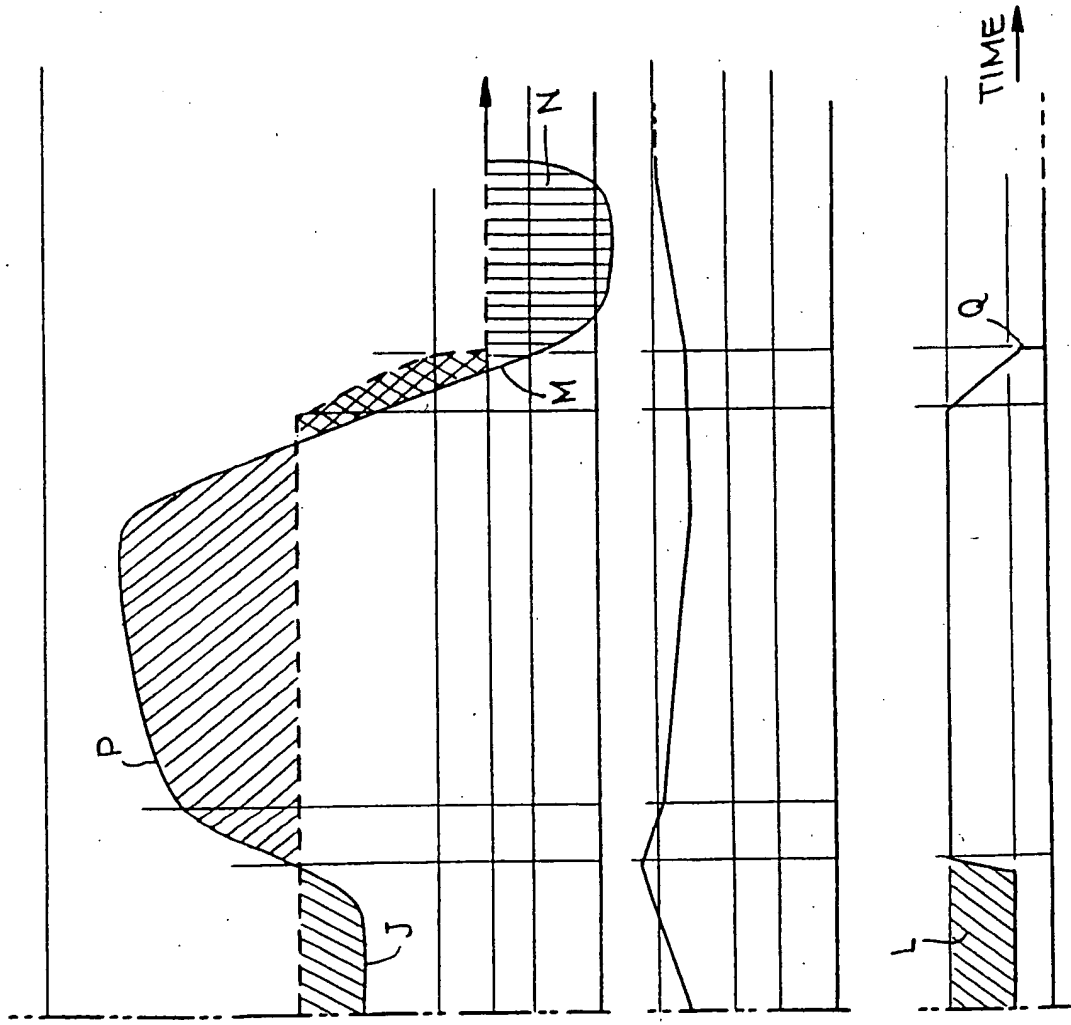

FIG. 7(a)  
(CONTINUED)

FIG. 7(b)  
(CONTINUED)

FIG. 7(c)  
(CONTINUED)

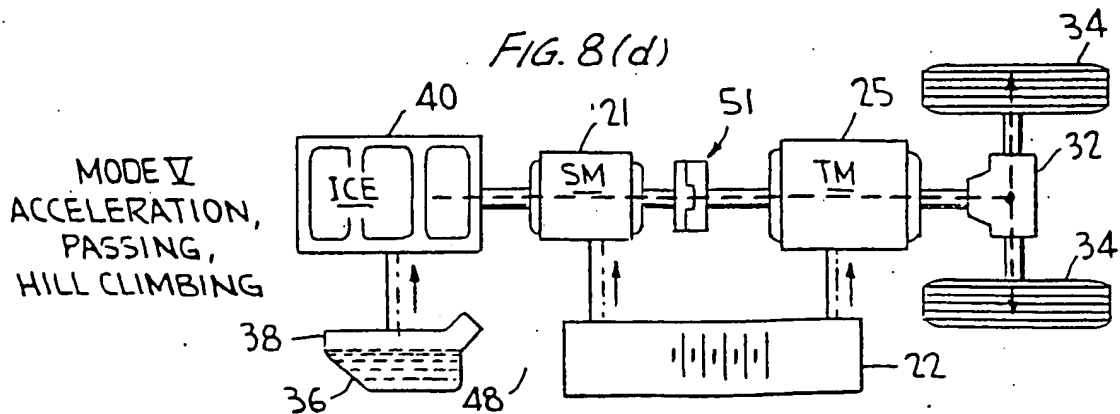
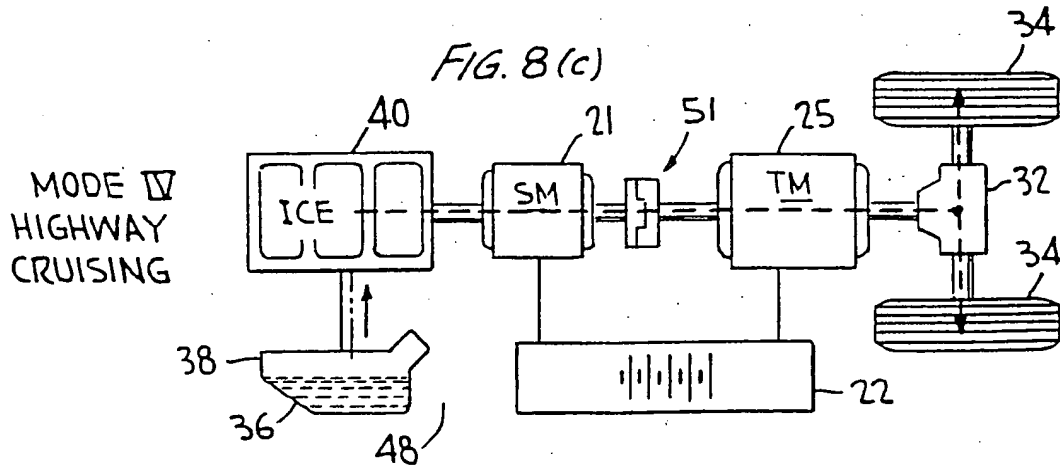
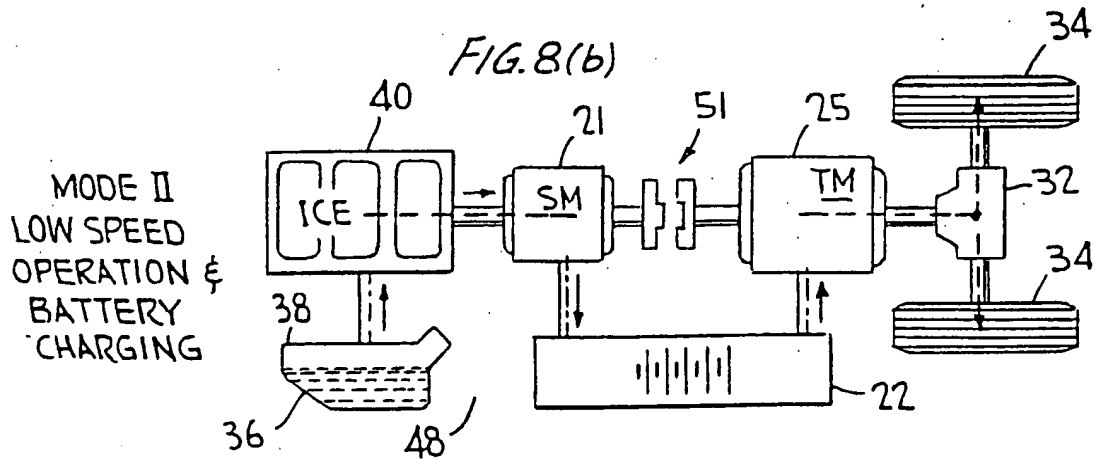
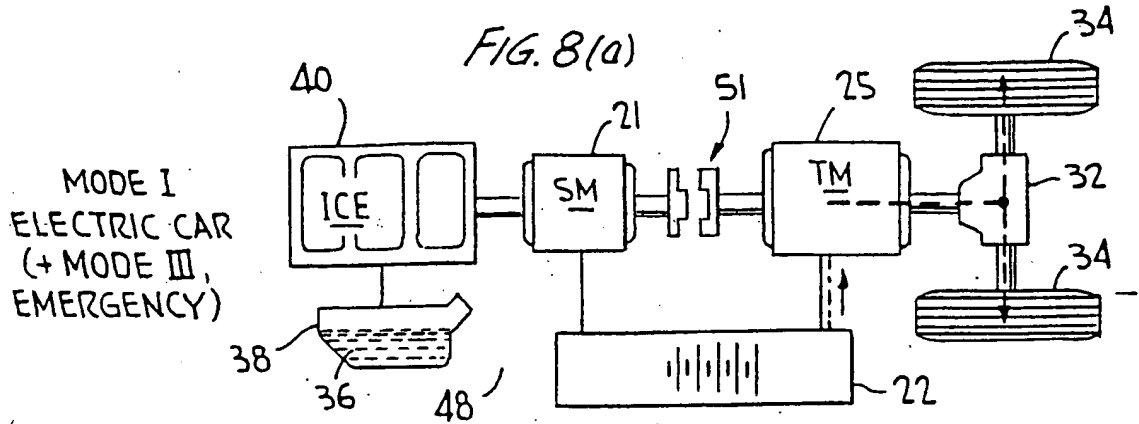
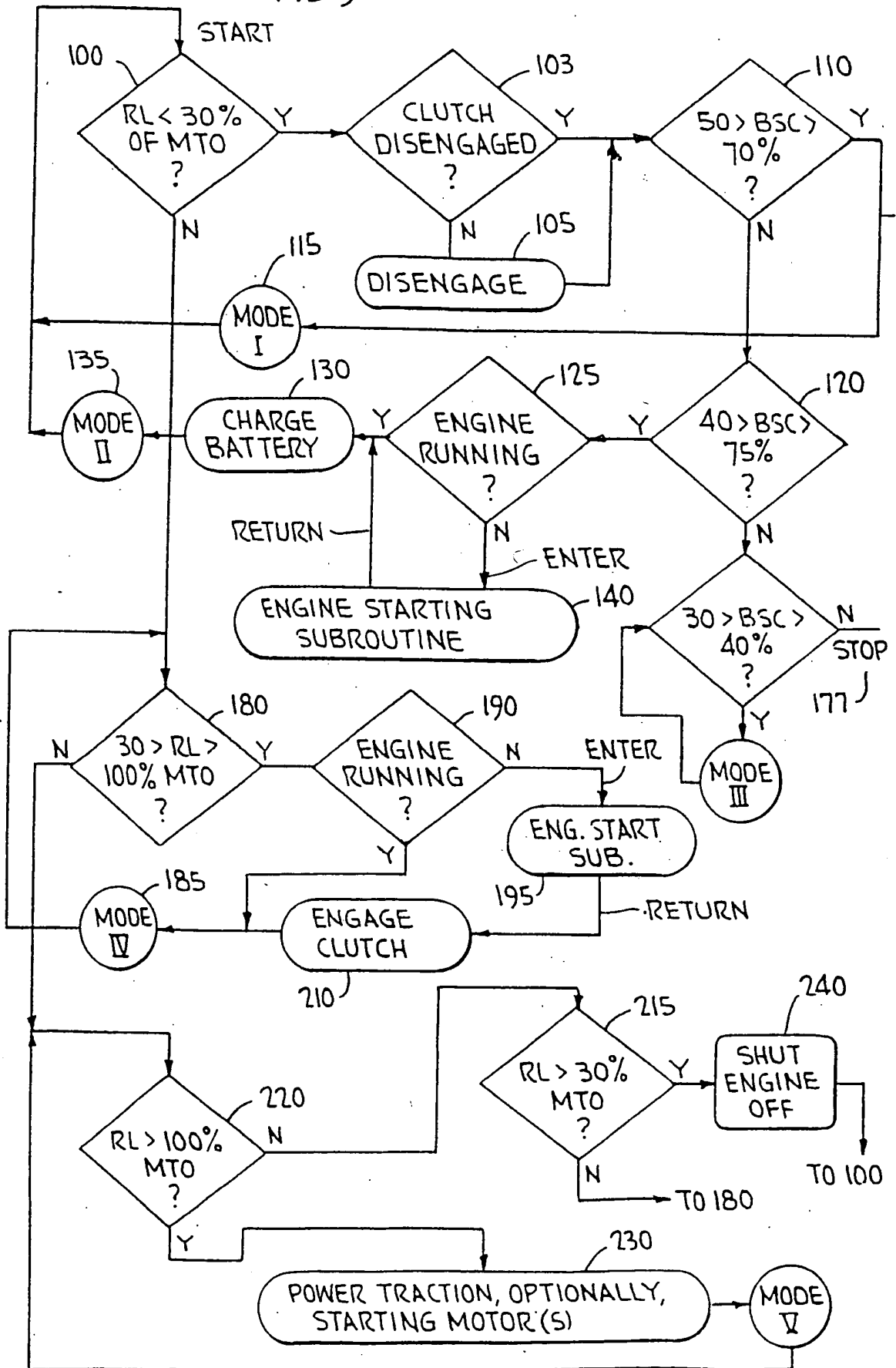



FIG. 9



SUBSTITUTE SHEET (RULE 26)

FIG. 9(a)  
ENGINE STARTING  
SUBROUTINE

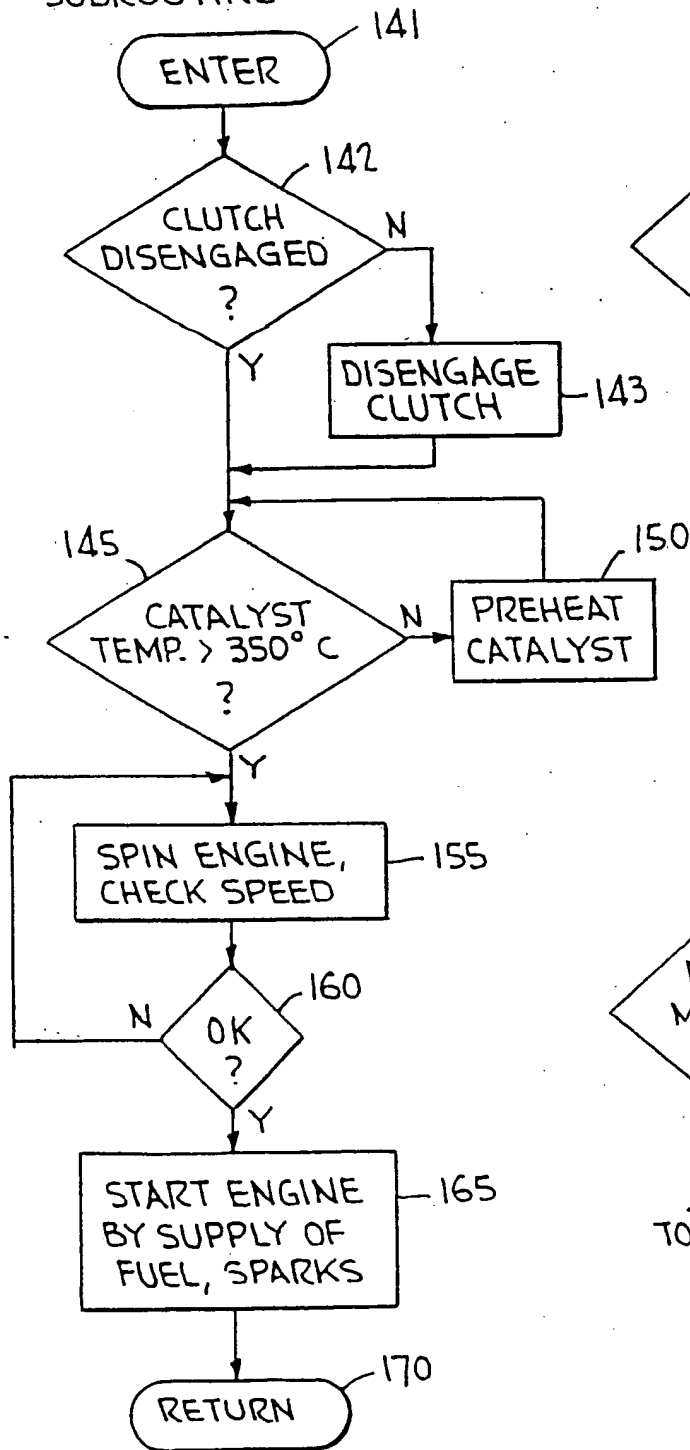

FIG. 9(b)

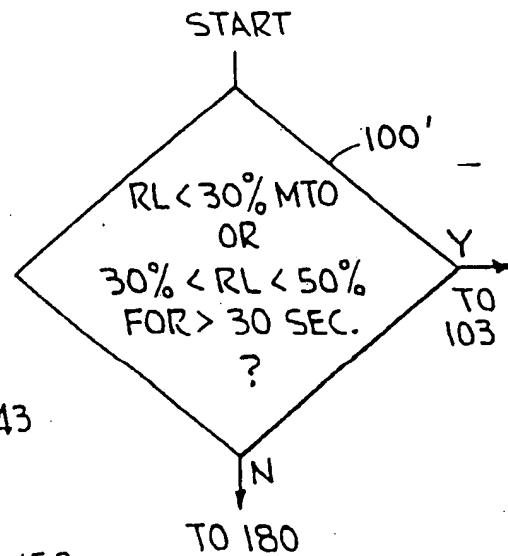
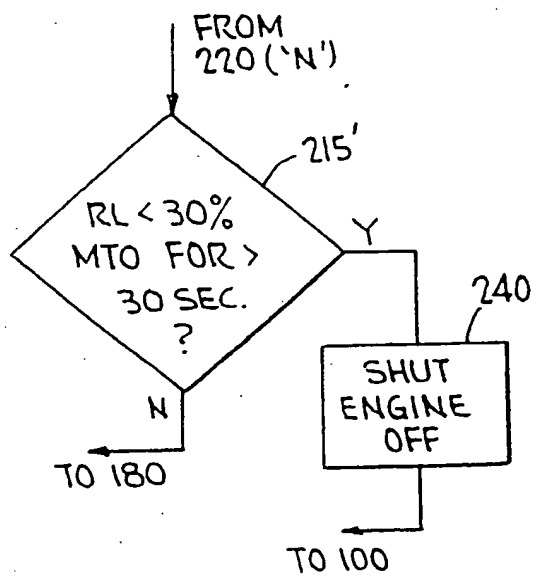

FIG. 9(c)



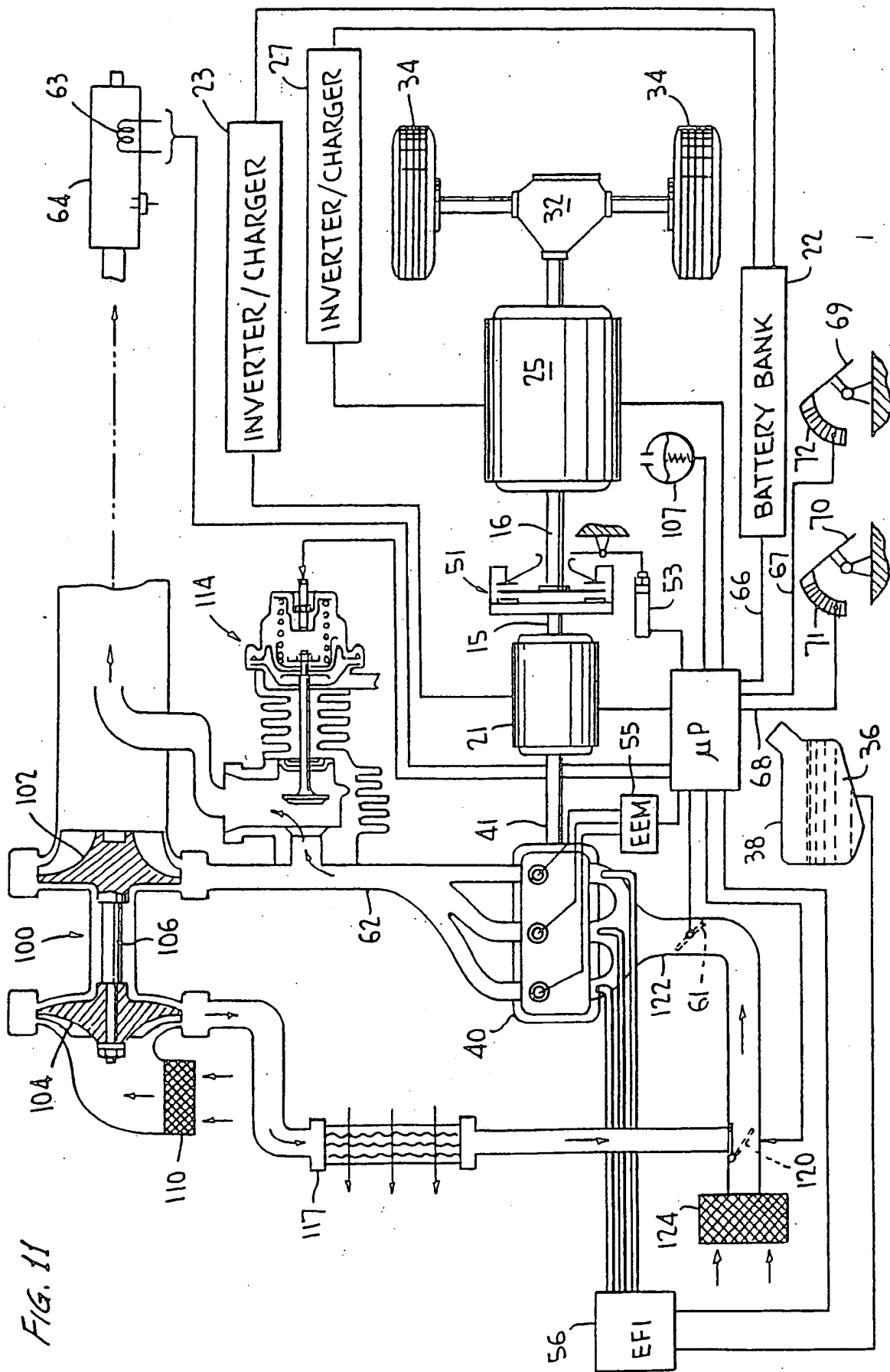

FIG. 11

SUBSTITUTE SHEET (RULE 26)

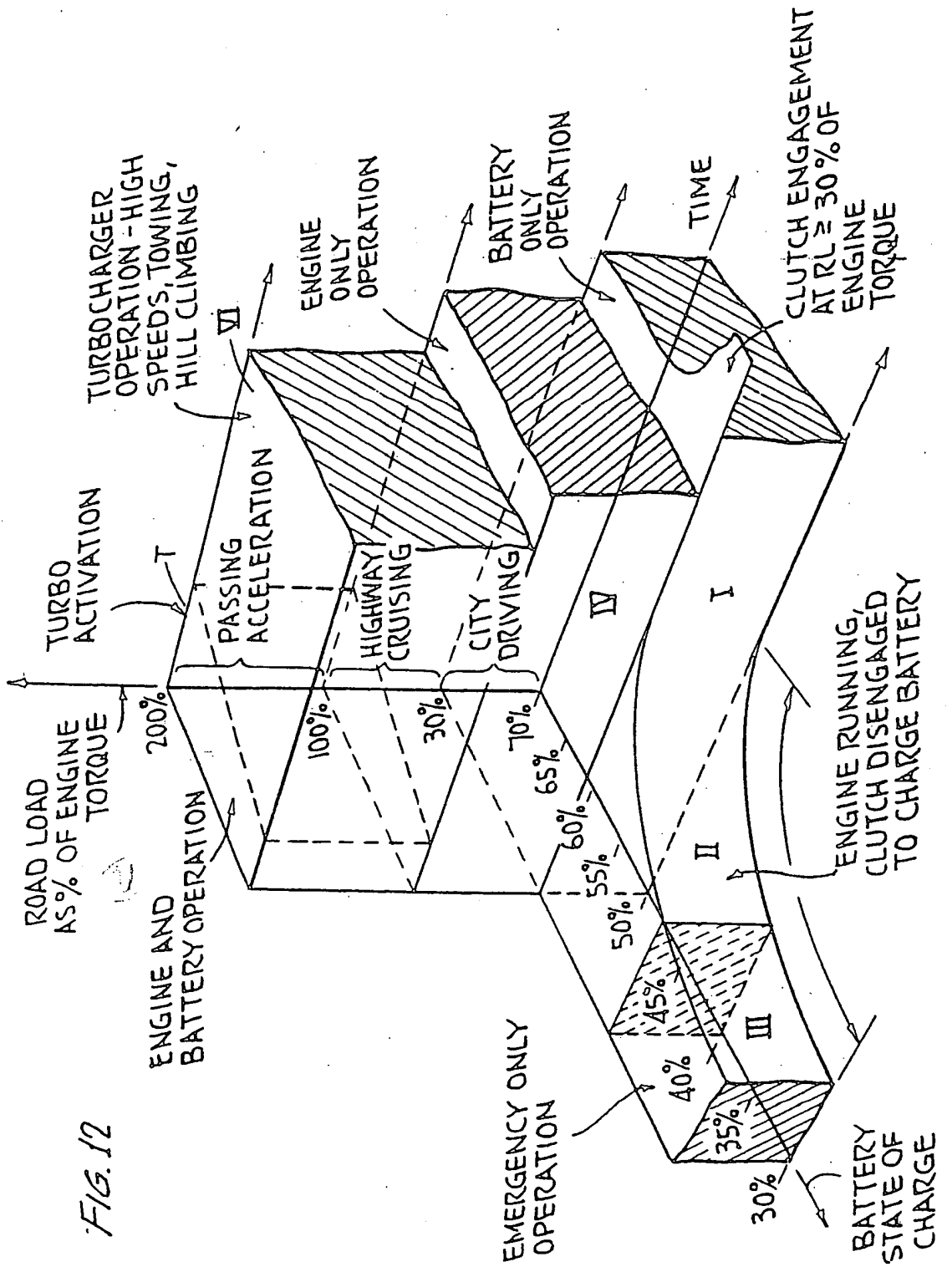

FIG. 12

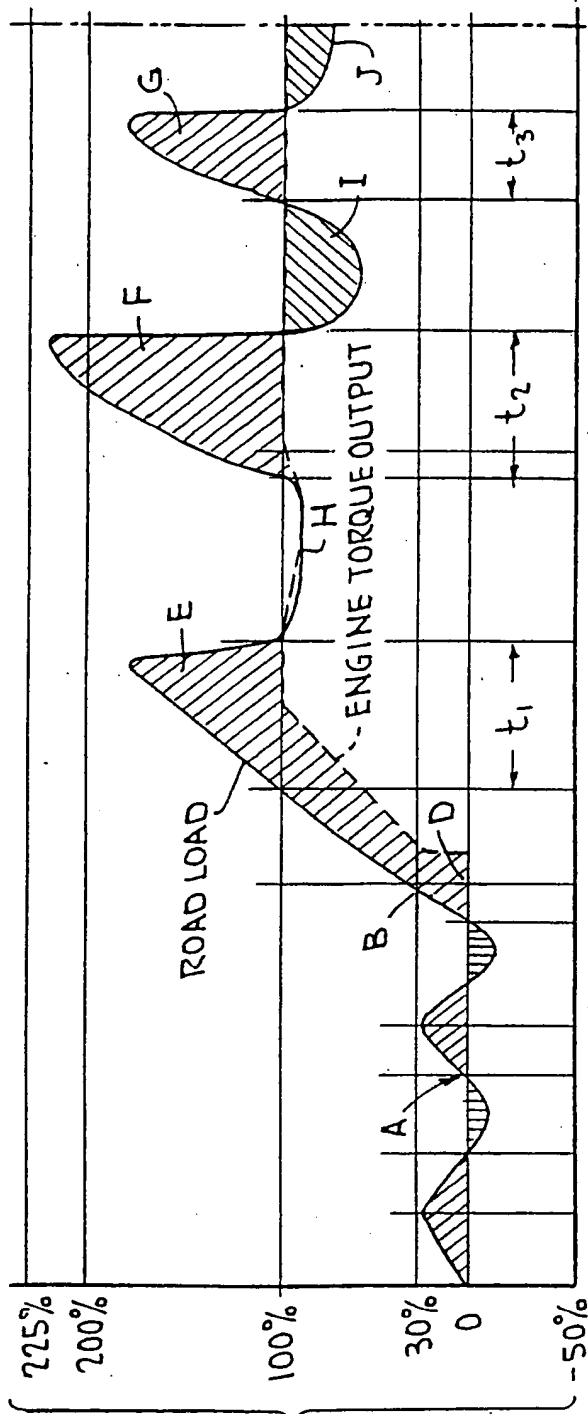

FIG. 13(a)  
ROAD LOAD AS %  
OF ENGINE'S MAX.  
TORQUE (NORMALLY  
ASPIRATED)

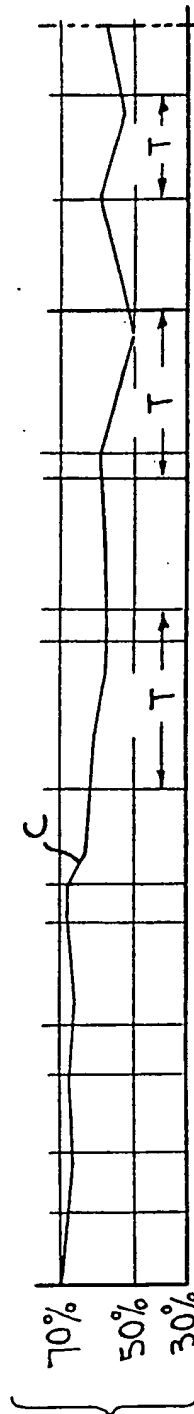

FIG. 13(b)  
BATTERY STATE  
OF CHARGE

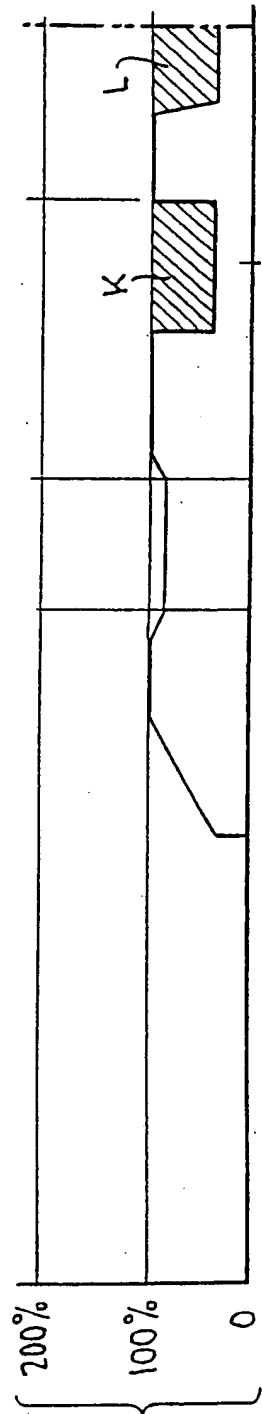

FIG. 13(c)  
ENGINE + TURBO-  
CHARGER OPERATION

SUBSTITUTE SHEET (RULE 26)

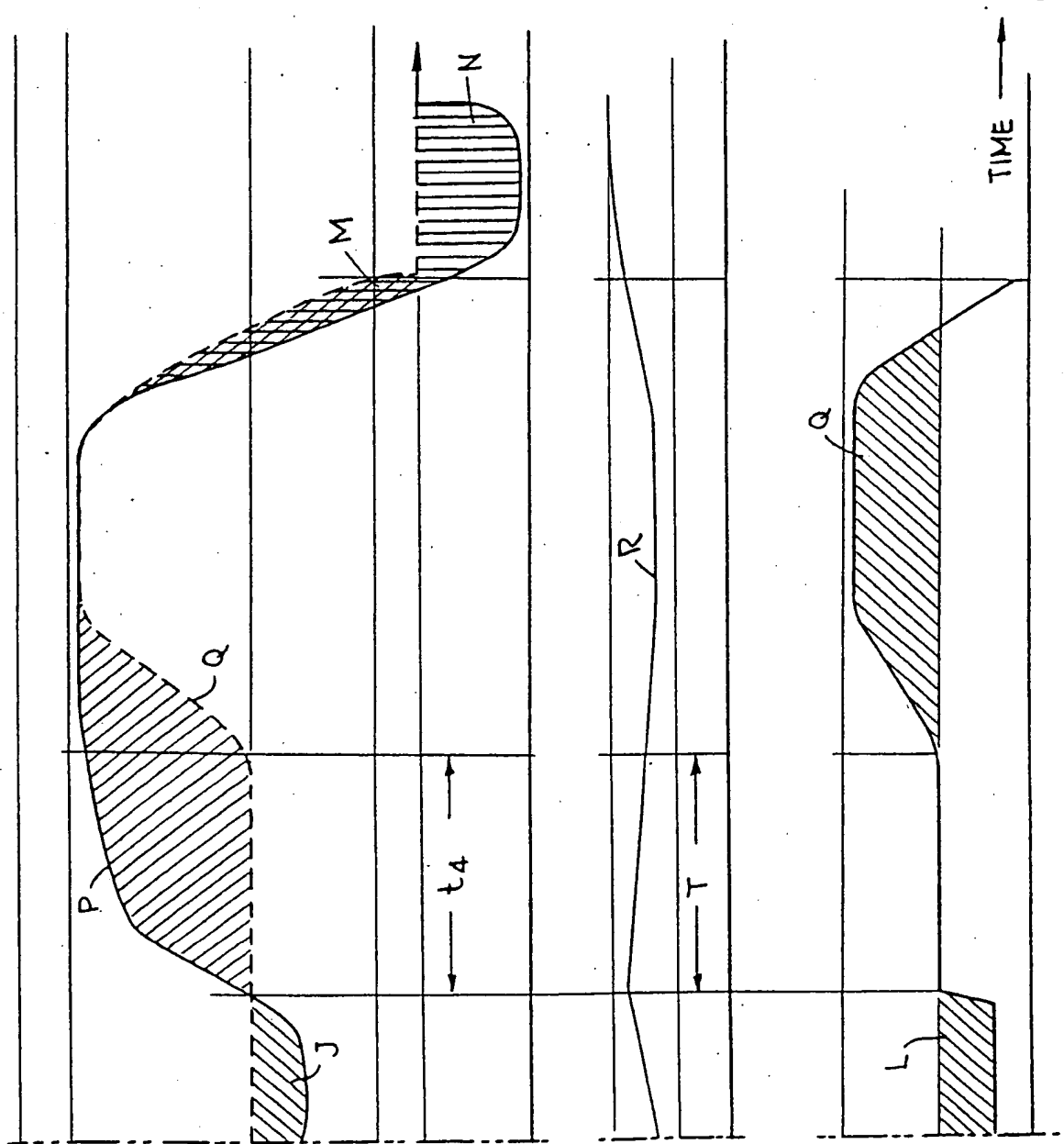

FIG. 13(a)  
(CONTINUED)

FIG. 13(b)  
(CONTINUED)

FIG. 13(c)  
(CONTINUED)

SUBSTITUTE SHEET (RULE 26)

15/17

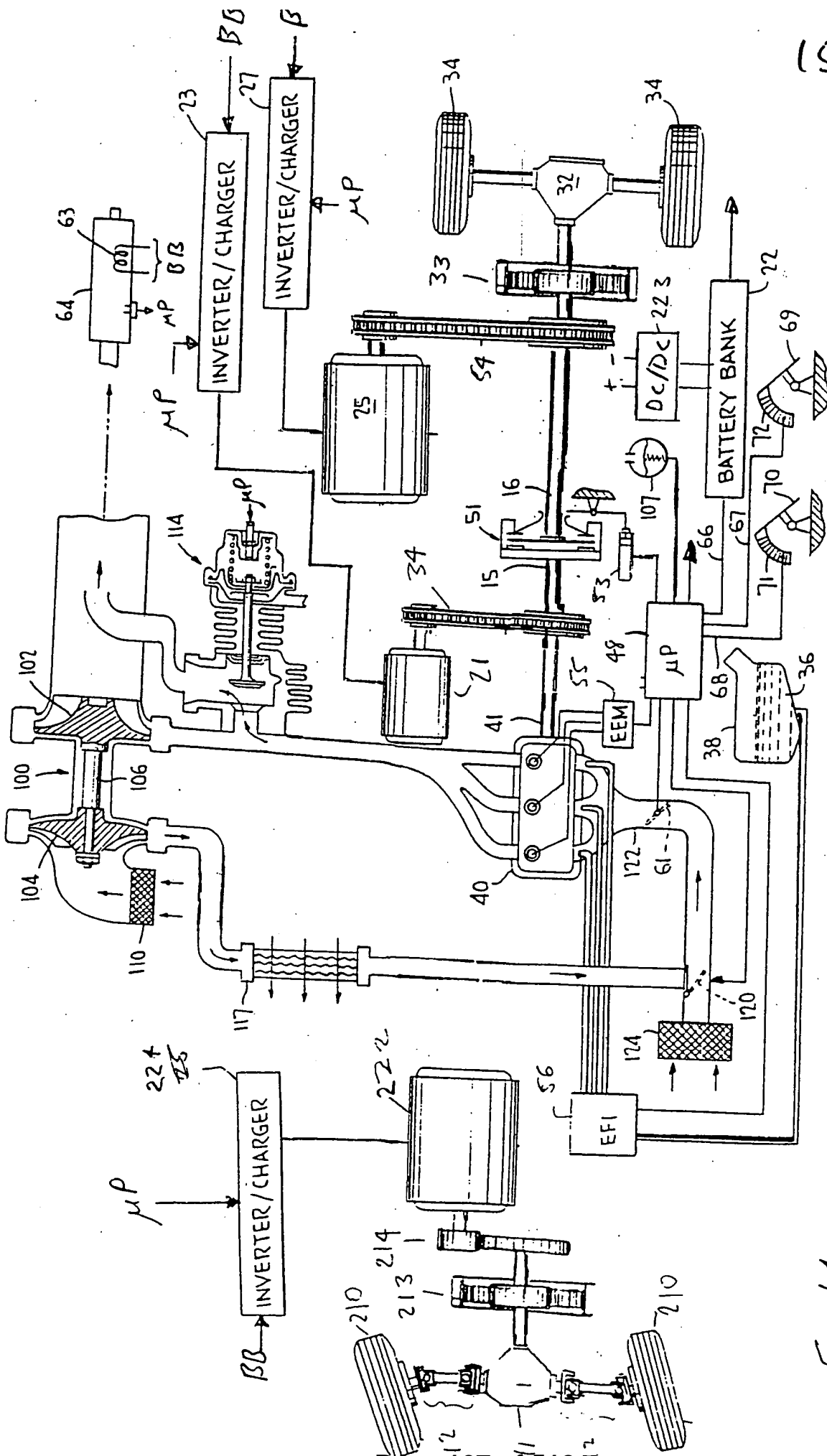
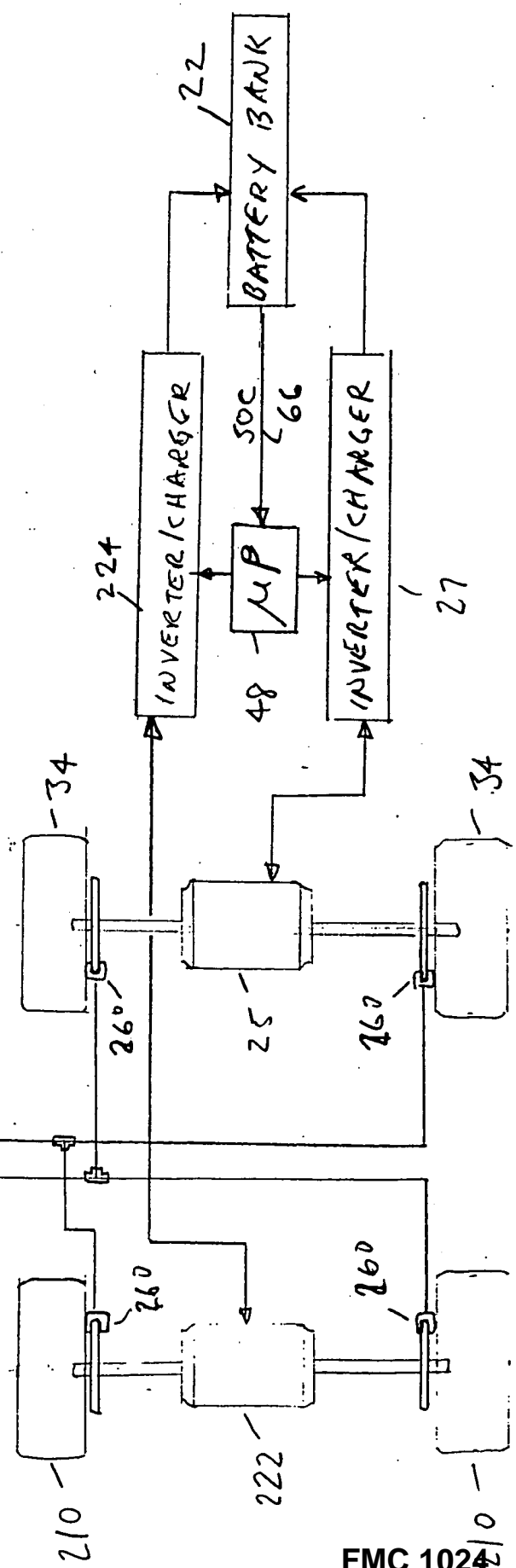
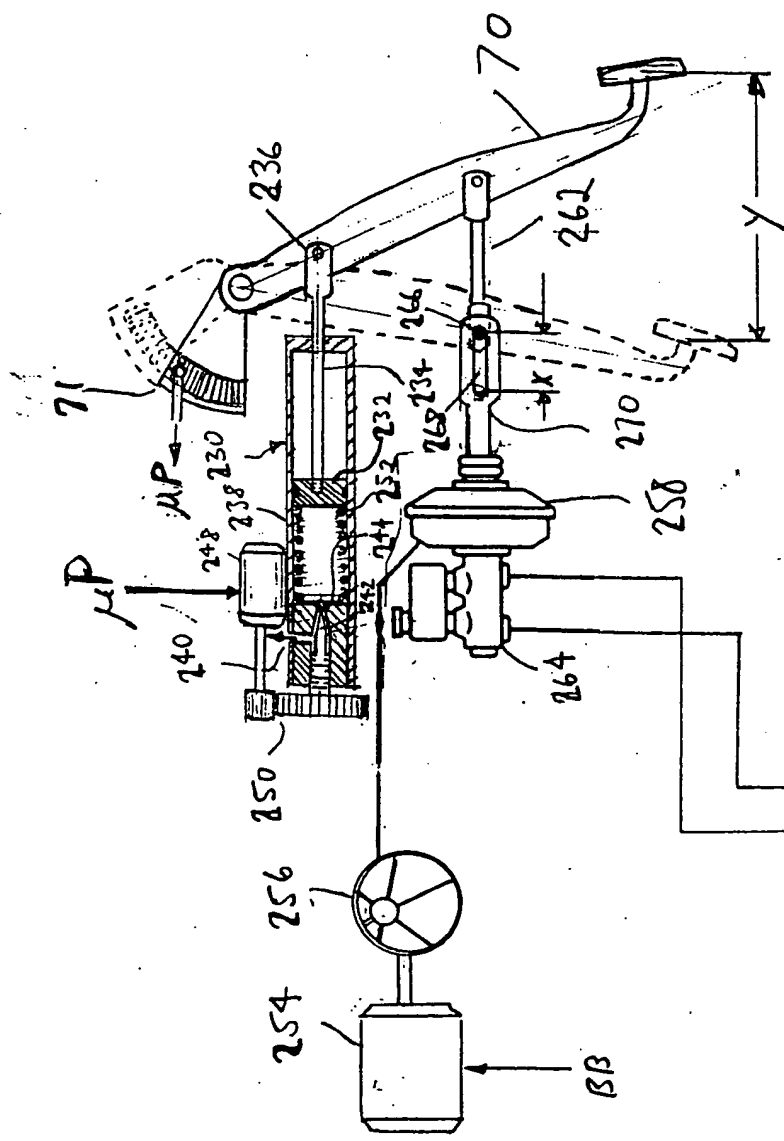

FIG. 14

FIG. 15





17/17

FIG 16

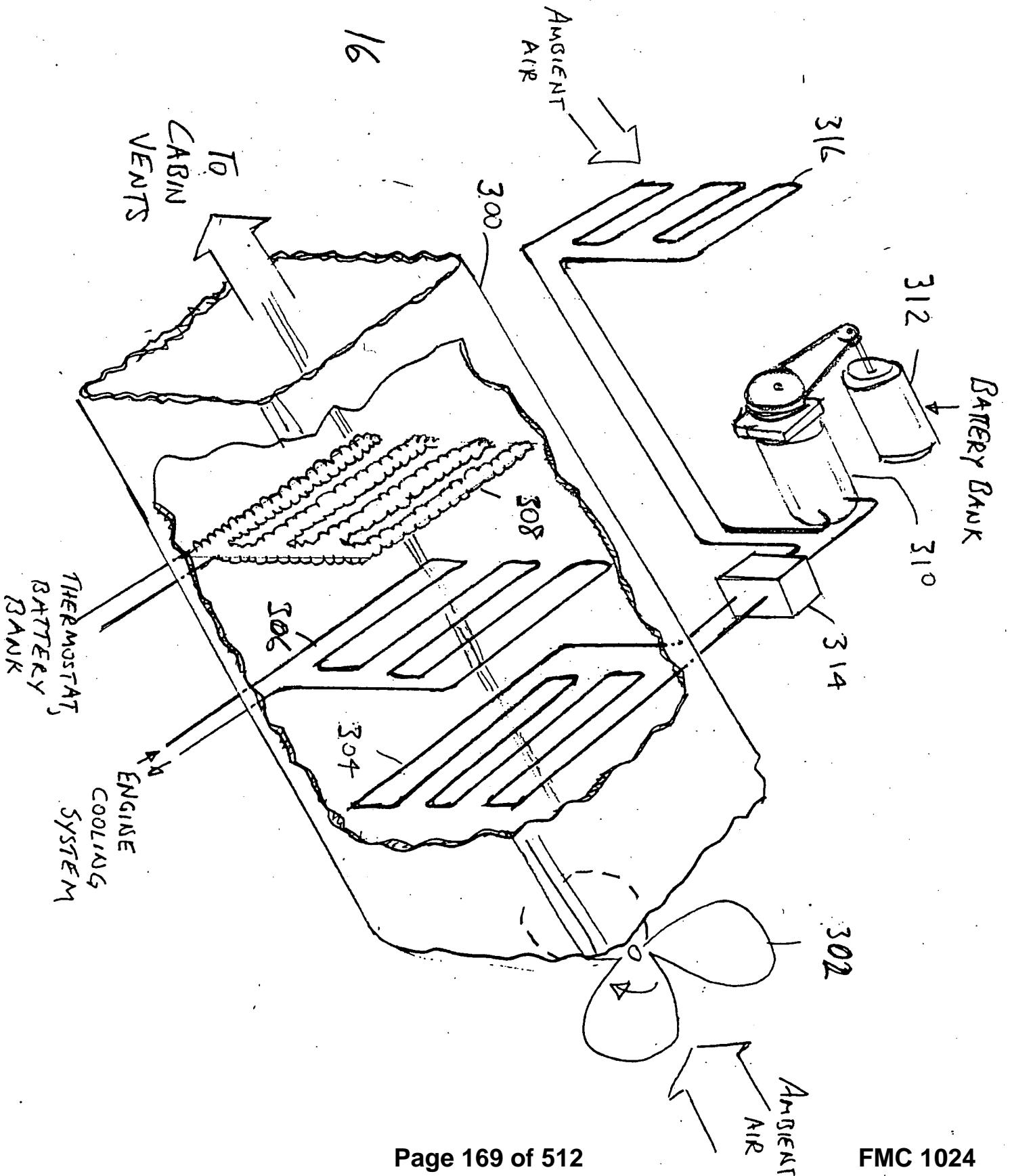

**This Page is Inserted by IFW Indexing and Scanning  
Operations and is not part of the Official Record**

**BEST AVAILABLE IMAGES**

Defective images within this document are accurate representations of the original documents submitted by the applicant.

Defects in the images include but are not limited to the items checked:

- BLACK BORDERS
- IMAGE CUT OFF AT TOP, BOTTOM OR SIDES
- FADED TEXT OR DRAWING
- BLURRED OR ILLEGIBLE TEXT OR DRAWING
- SKEWED/SLANTED IMAGES
- COLOR OR BLACK AND WHITE PHOTOGRAPHS
- GRAY SCALE DOCUMENTS
- LINES OR MARKS ON ORIGINAL DOCUMENT
- REFERENCE(S) OR EXHIBIT(S) SUBMITTED ARE POOR QUALITY
- OTHER: \_\_\_\_\_

**IMAGES ARE BEST AVAILABLE COPY.**

**As rescanning these documents will not correct the image problems checked, please do not report these problems to the IFW Image Problem Mailbox.**



UNITED STATES PATENT AND TRADEMARK OFFICE

UNITED STATES DEPARTMENT OF COMMERCE
United States Patent and Trademark Office
Address: COMMISSIONER FOR PATENTS
P.O. Box 1450
Alexandria, Virginia 22313-1450
www.uspto.gov

Table with 4 columns: APPLICATION NUMBER (11/429,457), FILING OR 371 (c) DATE (05/08/2006), FIRST NAMED APPLICANT (Alex J. Severinsky), ATTORNEY DOCKET NUMBER (PAICE201.DIV.3)

Michael de Angeli
60 Intrepid Lane
Jamestown, RI 02835

CONFIRMATION NO. 1951
FORMALITIES
LETTER

Date Mailed: 06/02/2006

NOTICE TO FILE MISSING PARTS OF NONPROVISIONAL APPLICATION

FILED UNDER 37 CFR 1.53(b)

Filing Date Granted

Items Required To Avoid Abandonment:

An application number and filing date have been accorded to this application. The item(s) indicated below, however, are missing. Applicant is given TWO MONTHS from the date of this Notice within which to file all required items and pay any fees required below to avoid abandonment. Extensions of time may be obtained by filing a petition accompanied by the extension fee under the provisions of 37 CFR 1.136(a).

- The statutory basic filing fee is missing. Applicant must submit \$ 300 to complete the basic filing fee for a non-small entity. If appropriate, applicant may make a written assertion of entitlement to small entity status and pay the small entity filing fee (37 CFR 1.27).

The applicant needs to satisfy supplemental fees problems indicated below.

The required item(s) identified below must be timely submitted to avoid abandonment:

- Additional claim fees of \$2100 as a non-small entity, including any required multiple dependent claim fee, are required. Applicant must submit the additional claim fees or cancel the additional claims for which fees are due.
To avoid abandonment, a surcharge (for late submission of filing fee, search fee, examination fee or oath or declaration) as set forth in 37 CFR 1.16(f) of \$130 for a non-small entity, must be submitted with the missing items identified in this letter.

SUMMARY OF FEES DUE:

Total additional fee(s) required for this application is \$3480 for a Large Entity

- \$300 Statutory basic filing fee.
\$130 Surcharge.
The application search fee has not been paid. Applicant must submit \$500 to complete the search fee.
The application examination fee has not been paid. Applicant must submit \$200 to complete the examination fee for a large entity

- The specification and drawings contain more than 100 pages. Applicant owes **\$250** for **27** pages in excess of **100** pages for a non-small entity.
- Total additional claim fee(s) for this application is **\$2100**
  - **\$2100** for **42** total claims over 20.

Replies should be mailed to:   Mail Stop Missing Parts  
  Commissioner for Patents  
  P.O. Box 1450  
  Alexandria VA 22313-1450

---

*A copy of this notice **MUST** be returned with the reply.*

T. Ketsela  
Office of Initial Patent Examination (571) 272-4000, or 1-800-PTO-9199, or 1-800-972-6382  
PART 3 - OFFICE COPY



UNITED STATES PATENT AND TRADEMARK OFFICE

UNITED STATES DEPARTMENT OF COMMERCE  
 United States Patent and Trademark Office  
 Address: COMMISSIONER FOR PATENTS  
 P.O. Box 1450  
 Alexandria, Virginia 22313-1450  
 www.uspto.gov

IFW\$

APPLICATION NUMBER	FILING OR 371 (c) DATE	FIRST NAMED APPLICANT	ATTORNEY DOCKET NUMBER
11/429,457	05/08/2006	Alex J. Severinsky	PAICE201.DIV.3

**CONFIRMATION NO. 1951**  
**FORMALITIES LETTER**

Michael de Angeli  
 60 Intrepid Lane  
 Jamestown, RI 02835

Date Mailed: 06/02/2006

**NOTICE TO FILE MISSING PARTS OF NONPROVISIONAL APPLICATION**

**FILED UNDER 37 CFR 1.53(b)**

*Filing Date Granted*

**Items Required To Avoid Abandonment:**

An application number and filing date have been accorded to this application. The item(s) indicated below, however, are missing. Applicant is given **TWO MONTHS** from the date of this Notice within which to file all required items and pay any fees required below to avoid abandonment. Extensions of time may be obtained by filing a petition accompanied by the extension fee under the provisions of 37 CFR 1.136(a).

- The statutory basic filing fee is missing.  
*Applicant must submit \$ 300 to complete the basic filing fee for a non-small entity. If appropriate, applicant may make a written assertion of entitlement to small entity status and pay the small entity filing fee (37 CFR 1.27).*

The applicant needs to satisfy supplemental fees problems indicated below.

The required item(s) identified below must be timely submitted to avoid abandonment:

- Additional claim fees of **\$2100** as a non-small entity, including any required multiple dependent claim fee, are required. Applicant must submit the additional claim fees or cancel the additional claims for which fees are due.
- To avoid abandonment, a surcharge (for late submission of filing fee, search fee, examination fee or oath or declaration) as set forth in 37 CFR 1.16(f) of \$130 for a non-small entity, must be submitted with the missing items identified in this letter.

06/23/2006 DENMANU1 00000040 040401 11429457

**SUMMARY OF FEES DUE:**

01 FC:1011	300.00 DA
02 FC:1051	130.00 DA
03 FC:1111	500.00 DA
04 FC:1311	200.00 DA
05 FC:1081	250.00 DA
06 FC:1202	2100.00 DA

Total additional fee(s) required for this application is **\$3480** for a Large Entity

- **\$300** Statutory basic filing fee.
- **\$130** Surcharge.
- The application search fee has not been paid. Applicant must submit **\$500** to complete the search fee.
- The application examination fee has not been paid. Applicant must submit **\$200** to complete the examination fee for a large entity

- The specification and drawings contain more than 100 pages. Applicant owes \$250 for 27 pages in excess of 100 pages for a non-small entity.
- Total additional claim fee(s) for this application is \$2100
  - \$2100 for 42 total claims over 20.

Replies should be mailed to: Mail Stop Missing Parts  
Commissioner for Patents  
P.O. Box 1450  
Alexandria VA 22313-1450

---

*A copy of this notice **MUST** be returned with the reply.*

*T. Ketsela*

Office of Initial Patent Examination (571) 272-4000, or 1-800-PTO-9199, or 1-800-972-6382  
PART 2 - COPY TO BE RETURNED WITH RESPONSE



IN THE UNITED STATES PATENT AND TRADEMARK OFFICE

In re the Patent Application of :

Severinsky et al	:	Examiner: N/A
Serial No.: 11/429,457	:	Group Art Unit: 3616
Filed: May 8, 2006	:	Att. Dkt.: PAICE201.DIV.3
For: HYBRID VEHICLES	:	

Mail Stop Missing Parts  
Hon. Commissioner for Patents  
P.O. Box 1450  
Alexandria VA 22313-1450

RESPONSE TO NOTICE TO FILE MISSING PARTS

Dear Sir:

In response to the Notice to File Missing Parts of Nonprovisional Application mailed June 2, 2006 (copy attached), setting a two-month period for response, kindly charge the total fees of \$3480 due for this application to Deposit Account No. 04-0401 of the undersigned.

- X 1. According to the Notice, the fee is calculated as follows:
- \$ 300 for basic filing fee
  - \$ 130 for late filing surcharge
  - \$ 2100 for extra claims (3 independent, 62 total claims)
  - \$ 500 for the search fee
  - \$ 200 examination fee
  - \$ 250 size fee
- Total \$ 3480

As above, kindly charge these and any further fees due in connection with this transaction (or credit any overpayment) to Deposit Account No. 04-0401 of the undersigned.

Respectfully submitted,

6/19/06  
Dated

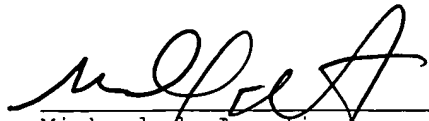
  
 Michael de Angeli  
 Reg. No. 27,869  
 60 Intrepid Lane  
 Jamestown, RI 02835  
 401-423-3190

IFW



IN THE UNITED STATES PATENT AND TRADEMARK OFFICE

re the Patent Application of :

Severinsky et al	:	Examiner: N/A
Serial No.: 11/429,457	:	Group Art Unit: 3616
Filed: May 8, 2006	:	Att.Dkt:PAICE201.DIV.3
For: Hybrid Vehicles	:	

Hon. Commissioner for Patents  
P.O. Box 1450  
Alexandria VA 22313-1450

INFORMATION DISCLOSURE STATEMENT

Sir:

This application is a divisional of Ser. No. 10/382,577. Incorporated herein by reference are the several Information Disclosure Statements (IDSs) that were filed in Ser. No. 10/382,577, and its predecessor, Ser. No. 09/822,866, now Patent 6,554,088. Copies of the IDSs thus incorporated are attached, together with the corresponding PTO-1449 forms. Where available the PTO-1449s attached are those returned by the Examiner, showing corrections that were noted in prosecution of the earlier applications. Copies of the documents thus cited were supplied in the parent and grandparent applications, or in earlier predecessor applications Ser. Nos. 09/264,817, now patent 6,209,672, and 09/392,743, now patent 6,338,391, and copies are accordingly not now being supplied herewith.

The Examiner is respectfully requested to consider the documents thus made of record, and to initial the PTO-1449 forms, indicating that he has done so.



Should there be any questions, the Examiner is invited to telephone the undersigned at the number given below.

Early and favorable action on the merits is earnestly solicited.

July 6, 2006  
Dated:

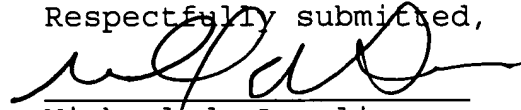
Respectfully submitted,  
  
Michael de Angeli  
Reg. No. 27,869  
60 Intrepid Lane  
Jamestown RI 02835  
401-423-3190



IN THE UNITED STATES PATENT AND TRADEMARK OFFICE

In re the Patent Application of	:	
Severinsky et al	:	Examiner: David Dunn
Serial No.: 10/382,577	:	Group Art Unit: 3616
Filed: March 7, 2003	:	Att.Dkt.: PAICE201.DIV
For: Hybrid Vehicles	:	

Hon. Commissioner for Patents  
P.O. Box 1450  
Alexandria VA 22313-1450

**FOURTH SUPPLEMENTAL INFORMATION DISCLOSURE STATEMENT**

Sir:

Applicant submits this Information Disclosure Statement for consideration by the Examiner. The issued patents from which this application claims priority have been asserted against Toyota Motor Corporation, Toyota Motor North America, Inc. and Toyota Motor Sales, USA, Inc. (collectively "Toyota") in civil action 2:04-CV-211 in the United States District Court for the Eastern District of Texas. A jury trial was recently conducted December 6-20, 2005, and a verdict holding the parent patents as valid but not infringed was returned.

Applicants submit herewith materials from this litigation for the purpose of full disclosure. Applicants respectfully request the Examiner to fully review and consider these materials in determining patentability of the present application. The materials submitted include transcripts of the trial and deposition testimony of the witnesses on whom Toyota relied for prior art assertions, with any confidential material redacted therefrom, together with copies of the documentary evidence discussed therein.

The materials also include a copy of the Court's Markman ruling construing the claims of the parent patents.

The Examiner is respectfully requested to consider these materials and indicate that he has done so in the file of this application.

Should the Examiner have any questions concerning the materials submitted, he is invited to telephone the undersigned at the number given below.

A Supplemental Notice of Allowability is earnestly solicited.

March 27, 2006  
Dated:

Respectfully submitted,

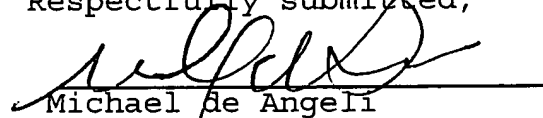

Michael De Angeli  
Reg. No. 27,869  
60 Intrepid Lane  
Jamestown, RI 02835  
401-423-3190



INFORMATION DISCLOSURE CITATION IN AN APPLICATION			DOCKET NUMBER PAICE201.DIV	APPLICATION NUMBER 10/382,577								
			APPLICANT Severinsky et al									
			FILING DATE 3/7/2003	GROUP ART UNIT 3616								
<b>U.S. PATENT DOCUMENTS</b>												
EXAMINER INITIAL	DOCUMENT NUMBER						DATE	NAME	CLASS	SUBCLAS	FILING DATE	
	5	3	7	1	4	1	2	12/1994	Iwashita			
	5	4	1	2	2	5	1	5/1995	Furutani			
	5	9	9	3	1	6	9	11/1999	Adachi et al			
	6	0	0	7	4	5	1	12/1999	Matsui et al			
	6	0	3	2	7	5	3	3/2000	Yamazaki et al			
	6	1	5	5	3	6	4	12/2000	Nagano et al			
	5	5	3	9	3	1	8	7/1996	Sasaki			
	5	6	8	0	0	5	0	10/1997	Kawai et al			
	5	9	6	4	3	0	9	10/1999	Kimura et al			
	5	8	8	3	4	9	6	3/1999	Esaki et al			
	5	9	0	5	3	6	0	5/1999	Ukita			
	6	1	5	8	5	4	1	12/2000	Tabata et al			
<b>FOREIGN PATENT DOCUMENTS</b>												
	DOCUMENT NUMBER						DATE	COUNTRY	CLASS	SUBCLASS	TRANSLATION	
											YES	NO
OTHER DOCUMENTS (Including Author, Title, Date, Pertinent Pages, Etc)												
	Trial and deposition transcripts of witnesses relied upon to assert inval- idity of parent patents in Civil Docket No. 2:04-CV-211-DF (E.D. Texas)											
	Claim construction order entered September 28, 2005 in Civil Docket No. 2:04-CV-211-DF (E.D. Texas)											
	Toyota Hybrid System, Toyota Press Information, Tokyo, 1997											
	Prius Hybrid EV, Toyota brochure, undated											
EXAMINER								DATE CONSIDERED				
EXAMINER: Initial if citation considered, whether or not citation is in conformance with MPEP §609; Draw line through citation if not in conformance and not considered. Include copy of this form with next communication to the applicant.												

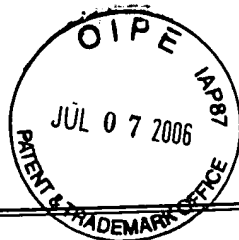

INFORMATION DISCLOSURE CITATION IN AN APPLICATION	DOCKET NUMBER	PAICE201.DIV	APPLICATION NUMBER	10/382,577
	APPLICANT			
	Severinsky et al			
FILING DATE		3/7/2003	GROUP ART UNIT	
			361	

**U. S. PATENT DOCUMENTS**

EXAMINER INITIAL	DOCUMENT NUMBER	DATE	NAME	CLASS	SUBCLAS	FILING DATE
	5 2 5 3 9 2 9	10/1993	Ohuri			
	5 3 2 6 1 5 8	7/1994	Ohuri			
	5 4 7 6 1 5 1	12/1995	Tsuchida et al			
	5 5 6 9 9 9 5	10/1996	Kusaka et al			
	5 6 3 7 9 7 7	6/1997	Saito et al			
	5 7 8 9 9 3 5	8/1998	Suga et al			
	5 8 9 5 1 0 0	4/1999	Ito et al			
	5 9 5 1 1 1 5	9/1999	Sakai et al			
	5 9 7 3 4 6 3	10/1999	Okuda et al			
	6 0 5 3 8 4 1	4/2000	Koide et al			
	5 9 2 9 5 9 4	7/1999	Nonobe et al			
	5 9 2 4 3 9 5	7/1999	Moriya et al			

**FOREIGN PATENT DOCUMENTS**

DOCUMENT NUMBER	DATE	COUNTRY	CLASS	SUBCLASS	TRANSLATION	
					YES	NO
0 1 3 6 0 5 5	03.04.85	European Patent Office				

**OTHER DOCUMENTS** (Including Author, Title, Date, Pertinent Pages, Etc)

	Miller et al, "Starter-Alternator for Hybrid Electric Vehicle.." (1996)
	Johnston et al, "The Design and Development of the [UC Davis].." (No date)
	Johnston et al, "The Design and Development of the [UC Davis].." (1997)
	Alexander et al, "A Mid-Sized Sedan Designed for High Fuel..." (No date)
	"PRIUS New Car Features", (Toyota manual) (1998)
	TRW Systems Group, "Analysis and Advanced Design Study..." (1971)

EXAMINER	DATE CONSIDERED
EXAMINER: Initial if citation considered, whether or not citation is in conformance with MPEP §609; Draw line through citation if not in conformance and not considered. Include copy of this form with next communication to the applicant.	



INFORMATION DISCLOSURE CITATION IN AN APPLICATION	DOCKET NUMBER	PAICE201.DIV	APPLICATION NUMBER	10/382,577
	APPLICANT	Severinsky et al		
	FILING DATE	3/7/2003	GROUP ART UNIT	361

**U.S. PATENT DOCUMENTS**

EXAMINER INITIAL	DOCUMENT NUMBER	DATE	NAME	CLASS	SUBCLAS	FILING DATE
	4 6 4 6 8 9 6	3/1987	Hammond et al			

**FOREIGN PATENT DOCUMENTS**

DOCUMENT NUMBER	DATE	COUNTRY	CLASS	SUBCLASS	TRANSLATION	
					YES	NO
0 7 6 9 4 0 3	23.4.1997	European Patent Office				
7 1 7 2 1 9 6	29.9.1994	Japan			X	
9 1 7 0 5 3 3	9.5.1996	Japan			abst.	
5 3 1 9 1 1 0	5.19.1992	Japan			abst.	
3 2 7 3 9 3 3	12.5.1991	Japan			abst.	

**OTHER DOCUMENTS** (Including Author, Title, Date, Pertinent Pages, Etc)

	Gelb, "An Electromechanical Transmission for Hybrid Vehicle..." (1971)
	Hirose et al, "The New High Expansion Ratio Engine..." (1997)
	Hong, "Toyota's Hybrid Program", <i>Road &amp; Track</i> , August 1997
	Law, "Toyota Tech", <i>Car &amp; Driver</i> , August 1997
	"Dual-Engine Fuel Saver", <i>Popular Mechanics</i> , July 1997
	"Toyota Launches Break-Through Hybrid EV", <i>Motor Trend</i> , September 1997

EXAMINER	DATE CONSIDERED
EXAMINER: Initial if citation considered, whether or not citation is in conformance with MPEP §609; Draw line through citation if not in conformance and not considered. Include copy of this form with next communication to the applicant.	

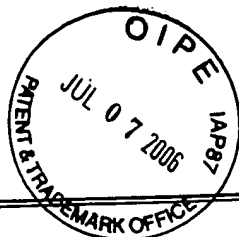

INFORMATION DISCLOSURE CITATION IN AN APPLICATION	DOCKET NUMBER	PAICE201.DIV	APPLICATION NUMBER	10/382,577
	APPLICANT	Severinsky et al		
	FILING DATE	3/7/2003	GROUP ART UNIT	361

**U.S. PATENT DOCUMENTS**

EXAMINER INITIAL	DOCUMENT NUMBER	DATE	NAME	CLASS	SUBCLAS	FILING DATE

**FOREIGN PATENT DOCUMENTS**

DOCUMENT NUMBER	DATE	COUNTRY	CLASS	SUBCLASS	TRANSLATION	
					YES	NO
7 2 6 8 9 2 2	10.17.1995	Japan			abst.	

**OTHER DOCUMENTS** (Including Author, Title, Date, Pertinent Pages, Etc)

	"Toyota touts advances in safety, emissions", <i>Automotive News</i> , 4/28/97
	"'96 North Wind Performance", undated
	Wakefield, "History of the Electric Automobile - Hybrid Electric Vehicles" (1998)
	"Escort 92-94", undated
	"Near-Term Hybrid Vehicle Program", General Electric Company (1979)

EXAMINER	DATE CONSIDERED
EXAMINER: Initial if citation considered, whether or not citation is in conformance with MPEP §609; Draw line through citation if not in conformance and not considered. Include copy of this form with next communication to the applicant.	

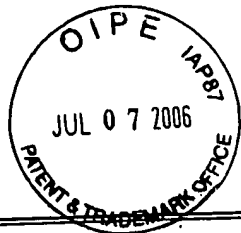

INFORMATION DISCLOSURE CITATION IN AN APPLICATION	DOCKET NUMBER	PAICE201.DIV	APPLICATION NUMBER	10/382,577
	APPLICANT	Severinsky et al		
	FILING DATE	3/7/2003	GROUP ART UNIT	361

**U.S. PATENT DOCUMENTS**

EXAMINER INITIAL	DOCUMENT NUMBER	DATE	NAME	CLASS	SUBCLAS	FILING DATE	
						YES	NO
	9 1 3 8 4 6	3/1909	Pieper				

**FOREIGN PATENT DOCUMENTS**

DOCUMENT NUMBER	DATE	COUNTRY	CLASS	SUBCLASS	TRANSLATION	
					YES	NO

**OTHER DOCUMENTS** (Including Author, Title, Date, Pertinent Pages, Etc)

	"Electric and Hybrid Vehicle Design Studies", SAE SP-1243 (1997)
	Gelb, "The case for Constant Speed Accessory Drives", (1975)
	Sasaki, "Toyota's Newly Developed Hybrid Powertrain", (1998)
	"Near-Term Hybrid Vehicle Program, Phase 1", General Electric Co. (1979)
	"Near-Term Hybrid Vehicle Program, Phase 1, App. A.", Gen'l Elec. (1979)
	"Joint Feasibility Study of Hybrid Vehicle, Final Report (1982)

EXAMINER	DATE CONSIDERED
EXAMINER: Initial if citation considered, whether or not citation is in conformance with MPEP §609; Draw line through citation if not in conformance and not considered. Include copy of this form with next communication to the applicant.	





INFORMATION DISCLOSURE CITATION IN AN APPLICATION	DOCKET NUMBER	PAICE201.DIV	APPLICATION NUMBER	10/382,577
	APPLICANT			
	FILING DATE	3/7/2003	GROUP ART UNIT	361

**U. S. PATENT DOCUMENTS**

EXAMINER INITIAL	DOCUMENT NUMBER	DATE	NAME	CLASS	SUBCLAS	FILING DATE	

**FOREIGN PATENT DOCUMENTS**

DOCUMENT NUMBER	DATE	COUNTRY	CLASS	SUBCLASS	TRANSLATION	
					YES	NO

**OTHER DOCUMENTS** (Including Author, Title, Date, Pertinent Pages, Etc)

	North American Technology Seminar plans, April 1997
	Hermance, THS Technical Explanation (undated)
	"Toyota" brochure describing Prius (undated)
	Hermance, "Toyota Hybrid System" (undated)

EXAMINER	DATE CONSIDERED
EXAMINER: Initial if citation considered, whether or not citation is in conformance with MPEP §609; Draw line through citation if not in conformance and not considered. Include copy of this form with next communication to the applicant.	

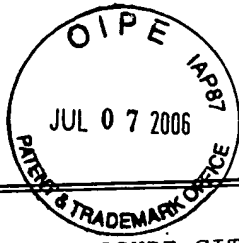

INFORMATION DISCLOSURE CITATION IN AN APPLICATION	DOCKET NUMBER	PAICE201.DIV	APPLICATION NUMBER	10/382,577
	APPLICANT			
	FILING DATE	3/7/2003	GROUP ART UNIT	361

**U.S. PATENT DOCUMENTS**

EXAMINER INITIAL	DOCUMENT NUMBER	DATE	NAME	CLASS	SUBCLAS	FILING DATE	
	5 4 1 2 2 9 3	5/1995	Minesawa et al				
	5 8 8 3 4 8 4	3/1999	Akao				

**FOREIGN PATENT DOCUMENTS**

DOCUMENT NUMBER	DATE	COUNTRY	CLASS	SUBCLASS	TRANSLATION	
					YES	NO
8 2 1 4 5 9 2	8.20.1996	Japan			abs t.	
1 0 6 6 3 8 3	3.6.1998	Japan			abs t.	

**OTHER DOCUMENTS** (Including Author, Title, Date, Pertinent Pages, Etc)

	Cuddy et al, "Analysis of the Fuel Economy Benefit..." SAE 970289 (1997)
	"Team Paradigm Shines in FutureCar Competition" (1996)
	Takaoka et al, "Study of the Engine Optimized for Hybrid System" (undated)
	Gelb et al, "Cost and Emission Studies of a Heat Engine/Battery.." (1972)
	Gelb et al, "Design and Performance Characteristics..." SAE 690169 (1969)
	"Electric/Hybrid Vehicles: Alternative Powerplants..." SAE SP-1284 (1997)

EXAMINER	DATE CONSIDERED
EXAMINER: Initial if citation considered, whether or not citation is in conformance with MPEP §609; Draw line through citation if not in conformance and not considered. Include copy of this form with next communication to the applicant.	



IN THE UNITED STATES PATENT AND TRADEMARK OFFICE

In re the Patent Application of :  
Severinsky et al : Examiner: David Dunn  
Serial No.: 10/382,577 : Group Art Unit: 3616  
Filed: March 7, 2003 : Att.Dkt.: PAICE201.DIV  
For: Hybrid Vehicles :

Hon. Commissioner for Patents  
P.O. Box 1450  
Alexandria VA 22313-1450

**SUPPLEMENTAL INFORMATION DISCLOSURE STATEMENT**

Sir:

The issued patents from which this application claims priority are being asserted against an alleged infringer in civil litigation in the United States District Court for the Eastern District of Texas. The defendants in that case have brought a number of new patents and other documents to applicants' attention. New documents have also been cited in a Complete Search Report prepared by the European Patent Office, dated May 5, 2005 (copy enclosed) against a European application claiming priority from the same US applications. These newly-cited patents and other documents thus located are listed on attached PTO-1449 forms, and are discussed below. The Examiner is respectfully requested to consider these new documents and to indicate that he has done so in the file of this application, and to then re-issue the Notice of Allowance mailed April 21, 2005.

Citation of a document herein should not be considered an admission that the disclosure thereof is indeed relevant to the invention defined by the claims, nor

that the document thus made of record is indeed effective as prior art under 35 USC 102.

It is respectfully submitted that although this Statement is being filed after issue of a Notice of Allowance, it is timely under 37 CFR 1.97 (e). The fee of \$180.00 (per 37 CFR 1.17(p)) is enclosed.

It is respectfully submitted that none of the newly-cited patents or other documents made of record hereby disclose or suggest the invention claimed herein. Early and favorable action on the merits of the application - specifically, issue of the patent, the Issue Fee having been paid concurrently with submission of this Statement - is earnestly solicited.

Dated:

6/30/05

Respectfully submitted,

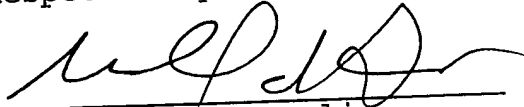

Michael de Angeli  
Reg. No. 27,869  
60 Intrepid Lane  
Jamestown, RI 02835  
401-423-3190



115

<b>INFORMATION DISCLOSURE CITATION IN AN APPLICATION</b>	DOCKET NUMBER	PAICE201.DIV	APPLICATION NUMBER	10/382,577
	APPLICANT			
	Severinsky et al			
FILING DATE		3/7/2003	GROUP ART UNIT	3616

**U. S. PATENT DOCUMENTS**

EXAMINER INITIAL	DOCUMENT NUMBER	DATE	NAME	CLASS	SUBCLASS	FILING DATE	
DD	5 8 4 4 3 4 2	12/1998	Miyatani et al				
DD	5 8 0 4 9 4 7	9/1998	Nii et al				
DD	5 4 5 7 3 6 3	10/1995	Yoshii et al				
DD	5 9 0 7 1 9 1	5/1999	Sasaki et al				
DD	5 9 1 4 5 7 5	6/1999	Sasaki				
DD	6 0 0 5 2 9 7	12/1999	Sasaki et al				
DD	6 1 6 6 4 9 9	12/2000	Kanamori et al				
DD	5 8 0 1 4 9 7	9/1998	Shamoto et al				
DD	5 9 0 9 7 2 0	6/1999	Yamaoka				
DD	5 6 9 8 9 5 5	12/1997	Nii				
DD	5 4 2 8 2 7 4	6/1995	Furutani et al				
DD	6 0 7 7 1 8 6	6/2000	Kojima et al				

**FOREIGN PATENT DOCUMENTS**

DOCUMENT NUMBER	DATE	COUNTRY	CLASS	SUBCLASS	TRANSLATION	
					YES	NO
2 4 1 9 8 3 2	3/1978	France			X	
3 1 2 4 2 0 1	10/1989	Japan			X	
51 1 0 3 2 2 0	2/1975	Japan			X	
H5 6 4 5 3 1	9/1984	Japan			X	
S 48 4 9 1 1 5	10/1971	Japan			X	

**OTHER DOCUMENTS** (Including Author, Title, Date, Pertinent Pages, Etc)

DD	Winkelman et al, SAE paper 730511, "Computer Simulation...." (1973)
DD	Berman et al, IEEE VT-23, NO. 3, pp. 61-72 "Propulsion Systems...." (1974)
DD	Berman SPC-TUE-2 "Battery Powered Regenerative SCR Drive" (1970)
DD	Gelb et al "Performance Analyses..." ACS pub (1972), pp 977-988
DD	Berman SPC-TUE-1 "Design Considerations...." (1971)
DD	Berman SPC-TUE-2 "All Solid State Method...." (1971)

EXAMINER	<i>[Signature]</i>	DATE CONSIDERED	10/12/05
----------	--------------------	-----------------	----------

EXAMINER: Initial if citation considered, whether or not citation is in conformance with MPEP §609: Draw line through citation if not in conformance and not considered. Include copy of this form with next communication to the applicant.



INFORMATION DISCLOSURE CITATION IN AN APPLICATION	DOCKET NUMBER	PAICE201.DIV	APPLICATION NUMBER	10/382,577
	APPLICANT			
	Severinsky et al			
FILING DATE		3/7/2003	GROUP ART UNIT	361

**U. S. PATENT DOCUMENTS**

EXAMINER INITIAL	DOCUMENT NUMBER	DATE	NAME	CLASS	SUBCLAS	FILING DATE	
						YES	NO
DD	5 9 9 1 6 8 3	11/1999	Takaoka et al				
DD	5 4 7 3 2 2 8	12/1995	Nii				
DD	5 9 2 7 4 1 5	7/1999	Ibaraki et al				
DD	5 9 2 8 3 0 1	7/1999	Soga et al				
DD	6 1 7 6 8 0 7	1/2001	Oba et al				
DD	5 9 0 4 6 3 1	5/1999	Morisawa et al				
DD	5 7 8 9 8 7 7	8/1998	Yamada et al				
DD	6 0 8 7 7 3 4	7/2000	Maeda et al				
DD	5 9 7 3 4 6 0	10/1999	Taga et al				
DD	5 9 8 8 3 0 7	11/1999	Yamada et al				
DD	5 9 9 1 6 8 3	11/1999	Takaoka et al				
DD	5 8 1 8 1 1 6	10/1998	Nakae				

**FOREIGN PATENT DOCUMENTS**

	DOCUMENT NUMBER	DATE	COUNTRY	CLASS	SUBCLASS	TRANSLATION	
						YES	NO
DD	S 50 3 0 2 2 3	7/1973	Japan			X	
DD	W O 82 0 11 7 0	4/1982	PCT				
DD	0 5 1 0 5 8 2	12/1995	EPO				
DD	4 2 9 7 3 3 0	3/1991	Japan				X

**OTHER DOCUMENTS** (Including Author, Title, Date, Pertinent Pages, Etc)

DD	Minorikawa et al, "Current Status and Future Trends..." (Undated)
DD	Baum et al "Semiconductor Technologies..." (Undated)
DD	Chen "Automotive Electronics in the Year 2000..." (Apparently 1992)
DD	Brusaglino, SAE paper 910244 "Electric Vehicle Development..." (1991)
DD	Anderson et al, SAE paper 910246 "Integrated Electric..." (1991)
DD	Burke, SAE paper 911914 "Battery Availability for Near-Term..." (1991)

EXAMINER	<i>[Signature]</i>	DATE CONSIDERED	10/12/07
----------	--------------------	-----------------	----------

EXAMINER: Initial if citation considered, whether or not citation is in conformance with MPEP §609; Draw line through citation if not in conformance and not considered. Include copy of this form with next communication to the applicant.



17

INFORMATION DISCLOSURE CITATION IN AN APPLICATION	DOCKET NUMBER PAICE201.DIV	APPLICATION NUMBER 10/382,577
	APPLICANT Severinsky et al	
	FILING DATE 3/7/2003	GROUP ART UNIT 361

**U. S. PATENT DOCUMENTS**

EXAMINER INITIAL	DOCUMENT NUMBER	DATE	NAME	CLASS	SUBCLAS	FILING DATE

**FOREIGN PATENT DOCUMENTS**

DOCUMENT NUMBER	DATE	COUNTRY	CLASS	SUBCLASS	TRANSLATION	
					YES	NO

**OTHER DOCUMENTS** (Including Author, Title, Date, Pertinent Pages, Etc)

A B C D	Chang, IEEE AES Magazine (1993) "Recent Developments of Electric ..."
	Kamiyama et al, IEEE 0-7803-0582-5 (1992) "Application Trends...."
	Sen, IEEE Trans. Ind. Elec. (1990) "Electric Motor Drives..."
	Wang et al, PCSC '71 Record, "Analysis of SCR Chopper Drive" (1971)
	EPRI Report TR-101264 "Assessment of Electric Motor Technology (1992)
	Berman et al, SAE paper 720111 "Electric Car Drives...." (1972)

EXAMINER <i>[Signature]</i>	DATE CONSIDERED 10/12/05
-----------------------------	--------------------------

EXAMINER: Initial if citation considered, whether or not citation is in conformance with MPEP §609; Draw line through citation if not in conformance and not considered. Include copy of this form with next communication to the applicant.

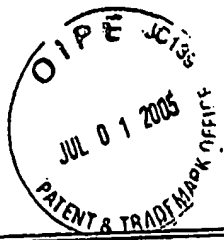

118

<b>INFORMATION DISCLOSURE CITATION IN AN APPLICATION</b>		DOCKET NUMBER PAICE201.DIV	APPLICATION NUMBER 10/382,577
APPLICANT Severinsky, et al			
FILING DATE 3/7/2003		GROUP ART UNIT 361	

**U. S. PATENT DOCUMENTS**

EXAMINER INITIAL	DOCUMENT NUMBER	DATE	NAME	CLASS	SUBCLAS	FILING DATE

**FOREIGN PATENT DOCUMENTS**

EXAMINER INITIAL	DOCUMENT NUMBER	DATE	COUNTRY	CLASS	SUBCLASS	TRANSLATION	
						YES	NO
DD	WO99 2 4 2 8 0	11/1997	PCT			X	
DD	EP07 4 3 2 1 1	5/1996	EP				
DD	EP08 3 9 6 8 3	10/1997	EP				

**OTHER DOCUMENTS (Including Author, Title, Date, Pertinent Pages, Etc)**

DD	Gelb et al, "The Application of Solid Electrolyte Batteries..." (Undated)
DD	Miller, "Integrated Power Module Requirements for Automotive..." (Undated)
DD	Vukosavic et al, IEEE Trans. Ind. App. "SRM Inverter Topologies..." (1991)

EXAMINER	DATE CONSIDERED 10/12/05
EXAMINER: Initial if citation considered, whether or not citation is in conformance with MPEP §609; Draw line through citation if not in conformance and not considered. Include copy of this form with next communication to the applicant.	





IN THE UNITED STATES PATENT AND TRADEMARK OFFICE

In re the Patent Application of :  
: Severinsky et al : Examiner: David Dunn  
: Serial No.: 10/382,577 : Group Art Unit: 3616  
: Filed: March 7, 2003 : Att.Dkt.:PAICE201.DIV  
: For: Hybrid Vehicles :

Hon. Commissioner for Patents  
P.O. Box 1450  
Alexandria VA 22313-1450

**SECOND SUPPLEMENTAL INFORMATION DISCLOSURE STATEMENT**

Listed on attached PTO-1449 forms are a number of documents that have come to applicants' attention since the filing of the Supplemental Information Disclosure Statement filed in this application on May 28, 2004. Applicants' thus making these documents of record should not be deemed a concession that they are necessarily available as prior art as defined by 35 USC Sect. 102. The Examiner is respectfully requested to consider these newly-cited documents and to indicate that he has done so in the file of this application.

The relevance of the newly-cited documents to the present invention is summarized as follows:

Japanese Patent Application Publication 7-54983  
(Nakagawa et al) (provided with noncertified translation)  
shows controlling the shifting of an automatic  
transmission. The usual method is described as controlling  
the ratio based on detected engine load and vehicle speed,

following a predetermined shift pattern. Prior art shows detecting increase in loading, e.g., "uphill running", if the speed drops below shift boundary line while the throttle opening is over a predetermined value. This is stated to be workable only under limited circumstances. This invention calculates a "running load coefficient KFUKA" which is then smoothed and used to correct the predetermined shift pattern.

From paragraph 10, "[T]he running load coefficient KFUKA is calculated according to an equation  $KFUKA=2-(b/a)$  when the detected vehicle speed 'b' is lower than the standard loaded-vehicle speed 'a', and according to an equation  $KFUFA=a/c$  when the detected vehicle speed 'c' is higher than the standard value 'a' ". This is mathematically inconsistent, since both "b" and "c" are the "detected vehicle speed". Further, it is clear that KFUKA is a running load coefficient, that is, a correction factor somehow responsive to variation in running load, not the running load itself.

Japanese Patent Application Publication 4-244568  
(Onishi et al) (provided with noncertified translation) -  
Shifting of an automatic transmission is controlled responsive to a predictive program that calculates the torque to be available after shifting. Running load is employed in this calculation. It is stated to be determined as follows:

"(0022) The running load estimating means 101 now multiplies the torque converter output torque  $T_t$  by the gear ratio "r" to calculate the torque  $T_m$  generated at the wheels, and calculates the running load  $T_L$  based on the

relational formula  $T_L = T_m - M \cdot r_w \cdot \alpha$  from the vehicle mass  $M$ , the effective wheel radius  $r_w$  and the acceleration  $\alpha$ . The flow of this calculation shown in FIG. 6.

"(0023) In FIG. 6,

Step 601: Reading of the respective data of vehicle speed  $V_{SP}$  and engine rotational speed  $N$ , gear ratio "r" and acceleration  $\alpha$  is performed.

Step 602: the turbine rotational speed  $N_t$  is calculated by the following formula:

$$N_t = V_{SP}/120\pi/r_w \cdot r \times 1000$$

Step 603: Torque converter or rotational ratio "e" is calculated and pump torque coefficient  $\tau$  and torque ratio "t" are searched.

$$e = N_t/N, \tau = f_1(e), t = f_2(e)$$

Step 604: Pump torque  $T_p$  and turbine torque  $T_t$  are calculated.

$$T_p = \tau \cdot (N/1000)^2, T_t = t \cdot T_p$$

Step 605: Calculation of torque  $T_m$ .  $T_m = T_p \cdot r$

Step 606: Calculation of running load  $T_L$ .  $T_L = T_m - M \cdot r \cdot \alpha$ .

This makes no sense. In particular, it is clear that the idea is to correct the torque at the wheels  $T_m$  by the factor  $M \cdot r \cdot \alpha$  to reach the running load, but calculating  $M \cdot r \cdot \alpha$  does not yield a torque in units of kg-m, but a value in  $\text{kg} \cdot \text{m}^2/\text{sec}^2$ .

In any event it is clear that neither reference refers remotely to hybrid vehicles, much less controlling operating modes thereof responsive to road load.

US Patent 6,067,801 (Harada) is based on Japanese application 9-329430. The disclosure is directed to reducing driveline shock occasioned upon shutting off the engine in a hybrid by loading it using one of the two motor/generators. Road load per se is not discussed; mode switching is discussed only inferentially, e.g., "...at the time when the engine is not required, for example, during a reduction of the speed or a downslope run, the hybrid vehicle stops operation of the engine 150 and runs only

with the motor MG2" (col. 9, lines 40 - 43). Harada states nothing of relevance to operating the engine when loaded to above a setpoint SP.

However, this reference is generally relevant in that it acknowledges that the engine can be loaded by the battery charging load as well as the loading required for vehicle propulsion (col. 1, lines 15 - 17), that the engine can be shut off when not needed (as noted, col. 9, lines 40 - 43) and that it should be operated at an efficient operating point (same). The vehicle's power requirements, including power for acceleration, for charging, and for auxiliaries, is calculated, and a decision made whether the engine is required. Engine activation is based on vehicle speed, or the necessity of battery charging (col. 10, line 41 - col. 11, line 18). The engine is run at low power levels (col. 12, line 49), and idling is permitted (col. 11, line 65). The engine can be motored to warm it up prior to starting (col. 12, line 17). It is noted that for a given output power requirement it is more efficient to run the engine at lower RPM and higher torque than at higher RPM and lower torque output (col. 13, lines 34 - 45). The minimum RPM of the engine in the loaded state is maintained greater than in the non-loaded state, in order to allow gentle variation in torque applied to the motor MG1 during mode changes, avoiding rough operation (col. 16, lines 17 - 38), not so as only to operate the engine when loaded to the point of efficient operation. Most of the topologies shown involve the usual planetary gearset for combining the torque from the engine and two motors, but an embodiment is shown in Fig. 12 which avoids the planetary gearbox and first motor in favor of a "clutch motor MG3" which includes first and second rotors that function as an

electromagnetic coupling (col. 18, lines 43 - 56). A series hybrid version, in which the engine never transmits torque directly to the wheels, is shown in Fig. 13.

Japanese Patent Application Publication 11-122712 (Morita et al) (provided with partial noncertified translation) shows a hybrid with a traction motor and engine propelling the vehicle; a second motor drives the ancillaries and starts the engine (there is no suggestion that this second motor is used to charge the battery), so the topology is effectively a single-motor hybrid with a separate starter. The invention is essentially to disengage a clutch connecting the engine and wheels upon braking, so that the engine can be shut off; when braking ends, the starter is used to motor the engine, and when the accelerator is then applied fuel is supplied and the engine started. Mode shifting is thus performed strictly in accordance with the operation of the accelerator and brake pedals.

Japanese Patent Application Publication 11-113956 (Hisamura) (provided with partial noncertified translation) shows a control device for a continuously variable transmission. The slope of the road being driven on is determined by a calculation employing the actual torque being supplied and the vehicle speed and acceleration. The "flatland" required torque is calculated and compared to the actual torque, to determine the slope of the road, and the transmission ratio adjusted accordingly.

Japanese Unexamined Patent Publication 11-82260 (Tsuzuki et al) (supplied without translation) - Topology

includes engine, first clutch, motor/generator, second clutch, and automatic transmission, and wheels, in that order. In order to reduce shock upon engine starting, the second clutch is opened and left open until the engine and motor/generator are synchronized. This would be completely useless, since power flow to the wheels would be interrupted, seriously impacting drivability. Moreover, this would occur under acceleration, just when it would be most annoying and possibly even unsafe.

Japanese Unexamined Patent Publication 11-82261 (Tsuzuki et al) (supplied without translation) is closely related to the above Tsuzuki patent application. According to notes provided by our searcher, this simply adds the idea of providing a starter on the engine. This would suffer the same drivability problem.

According to our German searcher, German applications 198 38 853, 102 60 435, and 198 14 402, (all supplied without translations) describe methods for starting the engines of single motor hybrids.

Fiala US patent 4,411,171 shows a single-motor hybrid wherein the engine is connected through a first clutch to one side of a flywheel; a second clutch on the other side of the flywheel allows the flywheel to be locked to the output shaft, for direct drive, or to serve as the sun gear of a planetary gearbox. The planet carrier is connected to the output shaft, and the ring gear to a single motor/generator. The flywheel can also be locked, which provides an electric-car mode. The vehicle must be stopped to allow starting of the engine (col. 3, line 55), so

clearly the vehicle must be operated in distinct low speed (electric car) and high-speed hybrid modes. The engine is to be used to start the vehicle from a standing stop by using some of the engine's torque to drive the motor/generator, i.e., the motor/generator acts as a brake (col. 5, lines 1 - 7), with the planetary gearbox thus decoupling the engine from the output shaft.

Maeda U.S. patent 3,620,323 shows a hybrid vehicle in which the engine is intended to be operated at full throttle at all times; see the abstract, col. 1, lines 37 - 38, col. 5, lines 13 - 15.

Tabata et al U. S. Patent 6,317,665 is directed to control of a lock-up clutch in a hybrid vehicle so as to smooth transitions between operation in motor-drive and engine-drive modes. Tabata et al patent 6,183,389 is also directed to control of operation of lock-up clutches. Finally, Tabata patent 5,887,670 is also directed to smoothing transitions.

Hagiwara patent 5,565,711 is the US equivalent to a Japanese patent document cited against a Japanese application claiming priority from the same basic application as the present application. The Hagiwara patent relates to specifics of the connection of the individual batteries in a battery bank. No claims are pending in this application which are drawn to this aspect of the invention.

Again, the Examiner is respectfully requested to consider these documents, and to indicate that he has done so in the file of the application.

Dated: 2/17/05

Respectfully submitted,

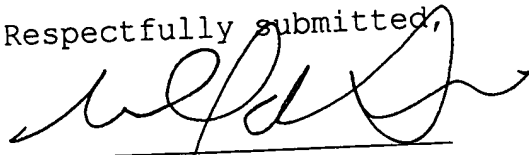

Michael de Angeli  
Reg. No. 27,869  
60 Intrepid Lane  
Jamestown, RI 02835  
401-423-3190



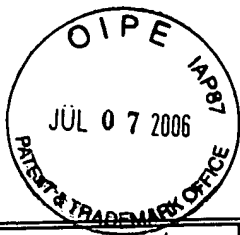
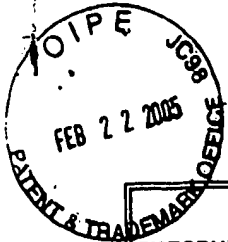

INFORMATION DISCLOSURE CITATION IN AN APPLICATION  1/2	DOCKET NUMBER	PAICE201.DIV	APPLICATION NUMBER	10/382,577
	APPLICANT			
	Severinsky et al			
FILING DATE		3/7/2003	GROUP ART UNIT	3616

**U.S. PATENT DOCUMENTS**

EXAMINER INITIAL	DOCUMENT NUMBER	DATE	NAME	CLASS	SUBCLAS	FILING DATE
DD	6 0 6 7 8 0 1 5	15/2000	Harada et al			
DD	4 4 1 1 1 7 1 1	10/1983	Fiala			
DD	3 6 2 0 3 2 3 5	1968	Maeda			
DD	6 3 1 7 6 6 5 11	11/2001	Tabata et al			
DD	6 1 8 3 3 8 9 2	12/2001	Tabata et al			
DD	5 5 6 5 7 1 1 1	10/1996	Hagiwara			

**FOREIGN PATENT DOCUMENTS**

EXAMINER INITIAL	DOCUMENT NUMBER	DATE	COUNTRY	CLASS	SURCLASS	TRANSLATION	
						YES	NO
DD	7 5 4 9 8 3	2/1995	Japan			X	
DD	4 2 4 4 6 5 8	9/1992	Japan			X	
DD	11 0 8 2 2 6 1 3	13/1999	Japan				X
DD	11 1 2 2 7 1 2	4/1999	Japan			Partial	
DD	62 1 1 3 9 5 6	5/1987	Japan			Partial	

**OTHER DOCUMENTS** (Including Author, Title, Date, Pertinent Pages, Etc)

EXAMINER <i>[Signature]</i>	DATE CONSIDERED 3/16/05
-----------------------------	-------------------------

EXAMINER: Initial if citation considered, whether or not citation is in conformance with MPEP 6609; Draw line through citation if not in conformance and not considered. Include copy of this form with next communication to the applicant.

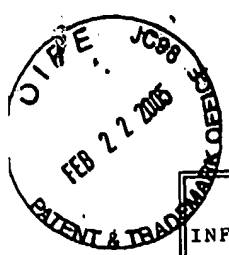

INFORMATION DISCLOSURE CITATION IN AN APPLICATION  2/2	SOCKET NUMBER PAICE201.DIV	APPLICATION NUMBER 10/382,577
	APPLICANT Severinsky et al	
	FILING DATE 3/7/2003	GROUP ART UNIT 361

**U.S. PATENT DOCUMENTS**

EXAMINER INITIAL	DOCUMENT NUMBER	DATE	NAME	CLASS	SUBCLASS	FILING DATE	
						YES	NO

**FOREIGN PATENT DOCUMENTS**

DOCUMENT NUMBER	DATE	COUNTRY	CLASS	SUBCLASS	TRANSLATION	
					YES	NO
DD 110822603	3/1999	Japan				X
DD 198388538	8/1998	Germany				X
DD 198144023	3/1998	Germany				X

**OTHER DOCUMENTS** (Including Author, Title, Date, Pertinent Pages, Etc)

EXAMINER  DATE CONSIDERED 3/16/05

EXAMINER: Initial if citation considered, whether or not citation is in conformance with MPEP §609; Draw line through citation if not in conformance and not considered. Include copy of this form with next communication to the applicant.

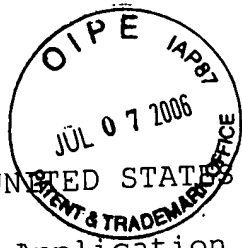

IN THE UNITED STATES PATENT AND TRADEMARK OFFICE

In re the Patent Application of :  
Severinsky et al :  
Serial No.: 10/382,577 :  
Filed: March 7, 2003 :  
For: Hybrid Vehicles :  
Hon. Commissioner for Patents :  
P.O. Box 1450 :  
Alexandria VA 22313-1450 :

Examiner: N/A  
Group Art Unit: 3616  
Att. Dkt.: PAICE201.DIV

**SUPPLEMENTAL INFORMATION DISCLOSURE STATEMENT**

Sir:

As discussed in the Preliminary Amendment dated August 11, 2003 in this application, applicants have performed additional searching for new patents possibly relevant to the subject matter of this application as amended, and other new patents and other documents have also come recently to applicants' attention. A number of patents and other documents thus located are listed on attached PTO-1449 forms, and are discussed below. Citation of a document herein should not be considered an admission that the disclosure thereof is indeed relevant to the invention defined by the claims, nor that the document thus made of record is indeed effective as prior art under 35 USC '102.

A correction is also desirable with respect to a statement made in an earlier Information Disclosure Statement (IDS). In the IDS filed on November 18, 1999 in grandparent application Ser. No. 09/264,817, which has been incorporated by reference to form part of the IDS for the present application, Taniguchi patent 5,846,155 was described as showing "a parallel hybrid of generally conventional topology, that is, comprising an ICE [internal combustion engine] and an electric motor connected to

the road wheels of the vehicle through a continuously-variable transmission, but discloses a relatively sophisticated operational scheme, wherein the source of propulsive torque varies in accordance with the road load and the state of charge of the battery bank ('SOC').

This could be misunderstood to suggest that Taniguchi suggests control of the hybrid vehicle's operating mode responsive to the road load and SOC. In fact, Taniguchi does not teach selection of the source of vehicle propulsive torque, much less the operating mode, in accordance with the road load and SOC, but in response to vehicle speed and accelerator pedal position. See col. 8, lines 13 - 40:

Moreover, the individual engagement means, as shown in FIGS. 4 and 5, are operated as shown in the operation diagram of FIG. 6. *In the power split mode, the split drive unit 9 functions at the start and at a low/medium speed.* The output of the engine 2 is transmitted to the ring gear R through the input clutch Ci. On the other hand, the rotor 5a of the motor-generator 5 is connected to the sun gear S to charge the engine output partially or to output it as the motor so that the composed force is output from the carrier CR to the CVT input shaft 7a.

On the other hand, *the parallel hybrid mode functions in a medium/high speed range.* In this state, the rotary elements of the planetary gear 6 are rotated together, and the output of the engine 2 is fed as it is to the CVT input shaft 7a. At the same time, the motor-generator 5 is connected to the input shaft 7a to assist the engine output or to charge the output partially.

*The motor mode is in the state in which the accelerator opening is small and in which the revolution number is small, e.g., in which the engine 2 need not be used, such as in a traffic jam. Then, the motor-generator 5 is used as the motor to drive the vehicle.* In this state, the input clutch Ci is released to disconnect the engine 2 and the CVT input shaft 7a, and the direct-coupled clutch Cd is applied to output the revolution of the motor-generator rotor 5a directly to the input shaft 7a.

*On the other hand, the engine mode functions during high speed cruising, and the vehicle is driven exclusively by the engine output without any participation of the motor-generator 5.* [Emphasis added].

The Examiner is respectfully requested to review the Taniguchi reference and confirm that in fact the road load is not used to determine the operating mode; in fact, Taniguchi controls the operation of the CVT, and the source of propulsive torque, in response to the vehicle speed and accelerator pedal position.

Turning now to new documents made of record hereby:

Abe 6,281,660 shows a battery charger for an electric vehicle.

Adler et al patent 5,515,937 claims a series hybrid where the power required by traction motors is drawn from either the batteries or directly from the engine/generator unit directly, depending on evaluation of their respective efficiencies and the batteries' state of charge, with respect to each new demand for power.

Barske patent 5,336,932 ties the operation of a generator used to charge a battery to specific fuel-consumption curves stored in ROM.

Bullock patent 6,170,587 shows a hybrid drive, all claims of which require at least three different types of energy storage, e.g., combustible fuel, battery, flywheel, or hydraulic accumulator.

Fattic et al patent 5,637,987 shows a hybrid vehicle in which an internal combustion engine and motor are coupled by controllable friction or electrical loading devices to control ratios.

Gray, Jr. patent 5,887,674 relates to a vehicle driven by a "fluidic motor", that is, having a hydraulic motor driving the wheels, in turn driven by a pump driven by an internal combustion engine.

Patent 4,762,191 to Hagin discloses a hybrid power train for a bus wherein multiple axles are driven via a driveshaft. Some of the dependent claims of the present application, recite connection of the combination of engine and first electric motor to a first set of wheels and connection of the second electric motor to a second set of wheels, which is quite different.

Hoshiya patent 6,315,068 shows a hybrid in which control of the torque provided by the motor is responsive to the torque provided by the engine, so that the engine can be operated at a target speed.

Ibaraki patent 5,856,709, discloses and claims a hybrid topology wherein an engine and a motor/generator are connected to different elements of a "synthesizing/distributing mechanism". A large number (nine or more) of operating modes are provided. The determination of the amount of torque required to propel the vehicle is apparently made in response to the position of the accelerator pedal; see col. 15, lines 59 - 61.

Patent 6,225,784 of Kinoshita claims a battery charge controller for a vehicle, wherein the level of charge above which further charging is permitted is varied based on the battery temperature. Patent 6,232,748 to the same inventor and assignee allows only discharge when the battery is above a specified temperature, and patent 6,204,636, again to the same inventor and assignee, controls the charging and discharge rate of the battery responsive to sensing of the "memory effect" of the battery. None of these expedients are claimed in the present application.

Four Lawrie and Lawrie et al patents, 5,993,350, 6,019,698, 5,979,257, and 6,006,620, and Reed et al 5,943,918 (et al here including Lawrie) are directed to transmissions for hybrids that combine the efficiency of manual transmissions with the convenience of automatic transmissions. Motors are used to operate the conventional "H"-pattern shifter, and a clutch, while

the motor/generator present in a hybrid is employed to match the speeds of input and output shafts, to ensure smooth shifting. Finally, Reed, Jr. et al 6,332,257 claims a method of converting a manual transmission to automated operation.

Lovatt et al patent 6,291,953 shows an "electrical drive system", in some cases applied to a hybrid vehicle, requiring a lock-up torque converter.

Minowa et al patent 6,142,907 (Hitachi) claims a hybrid wherein either an engine or a motor is used to propel the vehicle. A generator is selectively connected to the wheels through a two-speed transmission. Patent 6,328,670 is a continuation.

Morisawa et al 5,984,034 discloses a hybrid wherein regenerative braking is used to oppose engine torque when idling to keep the vehicle stopped. Morisawa et al 6,119,799 issued on a continuation and discloses a hybrid offering control of braking responsive to "obstruction [e.g., a car ahead] detection". Another patent based on the same underlying document, no. 6,334,498, claims supplying power from a motor during upshifts of an automatic transmission being driven by an engine. None of these is a feature of the claimed invention.

Another Morisawa patent, no. 5,895,333, is limited to packaging details for a planetary gearbox for a hybrid vehicle. Still another Morisawa patent, no. 6,306,057, claims a complex planetary gearbox arranged so that the internal combustion engine is used to power the vehicle when reversing.

Nagano et al 6,344,008 discloses a hybrid wherein a transmission is coupled between an engine and a torque synthesizing device, which also accepts torque from a single motor.

Nakajima et al 6,090,007 shows a control scheme for a hybrid vehicle including a continuously variable transmission. Patent

6,328,671 to Nakajima et al is a continuation-in-part of the '007 patent and shows setting the "target drive power" based on the accelerator pedal position and vehicle speed.

Nekola patent 5,660,077 shows a variable-speed transmission stated to be useful in a hybrid vehicle, including a cone-shaped gear; the meshing gear slides along the conical gear to vary their relative speeds.

Nitta patent 6,321,150 shows an abnormality monitoring system that is responsive to faults in a very specific type of communication scheme that can be used for a hybrid vehicle.

Another Nitta patent, no. 6,203,468, requires first and second motors on either side of a lock-up clutch, to smooth transitions between series and parallel operation.

Nogi et al patent application US 2001/0037905 is directed to lean-burn operation of a hybrid.

Omote patent 5,944,630 claims controlling torque applied by a motor during shifting operations, to smooth shift transitions.

Oyama patent 6,070,680 relates to prevention of stalling of the engine of a hybrid vehicle due to rapid deceleration; the traction motor provides torque to the engine in such cases.

Patent 6,123,642 to Saito claims a "speed change control apparatus" wherein a motor is connected to the wheels of a vehicle through a multispeed transmission; power to the transmission is cut during shifting.

Tabata et al patent 6,158,541 shows a hybrid vehicle wherein the battery is divided into several portions so that one or more can be completely discharged while the others remain partially charged.

A further Tabata et al patent, no. 5,847,469, is directed to a hybrid wherein the electric motor is employed for reversing if the battery is sufficiently charged, and the engine otherwise.



Another Tabata et al patent, no. 6,317,665, shows a hybrid in which a torque converter with lock-up clutch is disposed between the engine and motor and the wheels; the claims require the lock-up clutch to be released during mode switching to prevent rough running.

Another Tabata patent, no. 6,183,389, is directed to hybrids having "torque transmission systems" (i.e., torque converters; see col. 1, line 52) fitted with lock-up clutches; the invention has to do with the control system for the clutch.

Yet another Tabata et al patent, no. 5,873,426, claims a hybrid having an automatic transmission with differing shift patterns selected depending on the load; apparently, the engine is used as the only torque source in one mode and the engine and motor together in another.

Another Tabata et al patent, no. 5,923,093, recites in claim 1 that the automatic transmission is inhibited from shifting during regenerative braking, in claim 5 "braking shift control means" used when regenerative braking is not available, to downshift the transmission to increase engine braking, in claim 13 braking shift control means operated similarly prior to operation of regenerative braking, in claim 17 a clutch between transmission and engine that is engaged during regenerative braking, and in claim 23 means for preventing changing between engine and regenerative braking during a braking operation.

Still a further Tabata et al patent, no. 6,340,339, is limited to specific constructional details of a motor and transmission assembly for a hybrid.

In another Tabata et al patent, no. 5,935,040, claims 1, 5, 7, and 9 all require a manually-operated member for selecting drive modes, while claim 3 requires an automatic transmission operated so that the drive force remains constant in various drive modes as long as the required output remains constant.

Takaoka et al patent application US 2003/0085577 has claims drawn to control of gear selection in an automatic transmission for a hybrid based on engine efficiency; apparently, if the torque required cannot be supplied efficiently by the engine and motor working together, the transmission is downshifted.

Tuzuki et al patent 5,415,603 shows details of a hydraulic system for a hybrid vehicle in which the oil is used for cooling of a traction motor and lubrication of the transmission.

Wakuta et al patent 6,258,001 is directed to very narrow mechanical aspects of a motor and transmission assembly for a hybrid.

Woon et al patent 5,890,470 claims a method of controlling engine output power, evidently intended to improve on conventional governors as used on diesel engines to smooth throttle response and shifting. Claim 1 is typical and requires operating the engine at a constant horsepower value responsive to throttle position regardless of engine speed.

Yamada et al patent 6,328,122 discloses a series hybrid wherein the ICE can be used for vehicle propulsion only in the event of a failure in the charging system.

Nada patent 6,653,230 is also directed to operation of a hybrid after a particular failure.

Yamaguchi patent 5,915,489 shows a hybrid powertrain. It appears that the output torque is determined based on vehicle speed and accelerator pedal position; see col. 6, lines 17 - 21.

Yamaguchi et al patent 6,278,195 shows applying torque from the electric motor of a hybrid to quickly stop the engine.

Yamaguchi et al patent 6,247,437 claims control of the operation of a starter motor, e.g., for a hybrid, responsive to an engine parameter relevant to its startability. For example, if the engine is cold, fuel is supplied at a lower cranking RPM

to limit the drain on the battery. A divisional application (not being supplied), Yamaguchi et al published patent application 2001/0022166, similarly claims a starting control for an engine, in which the rotating speed is limited when the engine is cold to avoid excessive use of battery power.

Yamaguchi patent 5,967,940 is directed to control of the power provided by the engine of a hybrid to prevent noise due to gear backlash.

Yamaguchi 6,135,914 discloses a method of control of a hybrid including an ICE and two motor/generators. The invention has to do with limiting the engine speed so that the first motor/generator is not rotated beyond its capability in the event of a failure. The Yamaguchi system operates in engine-only, motor-only, and engine+motor modes (see col. 4, lines 46 - 54), but the method by which the choice between these is made is not explicit.

Field patent 5,081,365 discloses a hybrid vehicle wherein an engine is connected to road wheels through an electric motor, which is operated variously as traction motor or generator, depending on the batteries' state of charge and the vehicle operating mode; the operating mode is selected by the operator from an urban mode, a highway mode, an engine mode, and a cruise control mode. The selection is apparently to be made responsive to motor speed. Field acknowledges at col. 7, line 48 the desirability of operating the engine near its rated power to thus realize high efficiency; as discussed in detail below, Field suggest using an engine that is sized so that it operates at nearly maximum output during flat-highway, constant speed cruising. Such an engine would necessarily be too small to propel the vehicle up hills, so its performance would suffer under such circumstances.

Two additional patents to Field and Field et al, nos. 6,044,922 and 6,481,516, relate to developments of the system disclosed in the '365 Field patent above; the '516 patent is stated to be a continuation of the '922 patent, but their disclosures are not in fact identical. The vehicle described in these patents comprises two separate battery packs, a high-voltage battery pack for supplying power to the traction motor and a lower-powered accessory battery for operating usual vehicle ancillary components such as lights, radio, and the like.

Kubo patent 5,722,502 shows a hybrid vehicle comprising an ICE, a generator and a traction motor also operable as a generator. The vehicle can be operated in a variety of modes, include PEV ("pure electric vehicle", in which the ICE is not run at all; see col. 10, lines 18 - 28), SHV ("serial electric vehicle", wherein the ICE is run to drive the generator, which in turn supplies current to the traction motor to power the vehicle; see col. 5, lines 33 - 51), and "continuous-type PSHV" ("parallel-serial hybrid vehicle", where torque from the ICE is used to propel the vehicle and to drive the generator to power the traction motor to propel the vehicle if torque from the ICE is inadequate; see col. 5, lines 52 - 66). A distinction is drawn between this continuous-type PSHV and a "changeover-type PSHV", as exemplified by Japanese Laid-Open Publication 2-7702; see col. 3, lines 2 - 9 and col. 5, line 66 - col. 6, line 10.

The selection between the PEV mode and one or the other of the SHV and PSHV modes is made by the operator (see col. 10, line 47), while the selection between SHV and PSHV modes is made according to the battery's state of charge (SOC); see col. 6, lines 12 - 13. When the driver selects a mode other than the PEV mode, the engine is operated continuously (col. 11, lines 26 - 32), and may idle when not significantly loaded (col. 12, lines 31 - 32; col. 13, lines 51 - 52); if the battery is fully charged

but braking is required, such that regenerative braking would be inappropriate, the engine can be operated as a mechanical brake (col. 11, lines 6 - 20).

In PSHV mode, an engine control unit (ECU) then determines whether torque is to be supplied from the traction motor, ICE, or both, depending on the accelerator pedal angle: "Further, if the change in accelerator pedal angle is too large for the torque to be supplied...by the ICE alone or...by the ICE alone because fuel consumption and emission are degraded, the ECU 20 controls the [inverter] to compensate by using the motor 10 for at least that part of the torque required at the driving wheels." (Col. 13, lines 32 - 39). At low speeds in PSHV mode, it appears that the ICE provides power to the traction motor through the first motor, being operated as a generator.

Tsukamoto et al 5,771,478 shows a hybrid vehicle in which the function of a clutch or torque converter, allowing slipping of an ICE with respect to the wheels of a vehicle, e.g., when accelerating from a stop, is provided by a gearbox connected between the ICE, wheels, and a motor-generator. Excess torque provided by the ICE at starting is absorbed by the motor-generator and stored in a battery; it can then be used to run accessories or propel the vehicle.

Tabata et al 5,833,570 relates to smoothing the shifting of an automatic transmission of a hybrid by application of torque from the traction motor. Tabata 5,951,614 is generally similar, but shows smoothing of shifting by reducing the torque supplied by either the motor/generator or ICE.

Hata et al 5,875,691 discloses and claims a specific arrangement of the components of a hybrid (ICE, motor, transmission) for packaging convenience.

Haka 5,931,271 shows a hybrid powertrain wherein one-way clutches are provided so that the same motor/generator can start

an ICE and be disconnected therefrom for efficient regenerative braking.

Shibata et al patent 3,719,881 shows a battery charger arrangement especially for a serial hybrid vehicle, wherein an internal combustion engine is operated to drive a generator only above a minimum load, so as to reduce emissions, which increase at low loads.

Etienne patent 4,187,436 also shows a battery charging arrangement for a serial hybrid vehicle, which includes a first battery for powering the traction motor and a second battery for starting the ICE.

Lynch et al patent 4,165,795 shows a hybrid drive arrangement in which an ICE and a motor/generator are mechanically coupled to one another, and to the wheels of the vehicle, through a transmission. The engine is sized to provide the average power necessary for ordinary driving, and is operated near its optimal efficiency point at all times; the motor/generator is operated for load-leveling, that is, when the vehicle's torque requirements exceed the power provided by the engine the motor/generator adds torque, and when the engine's torque output exceeds the vehicle's torque requirement, the motor/generator operates as a battery charger. The difficulty with this approach is simply that the vehicle's torque requirements may vary by a factor of up to 1000%, or more, between city driving and highway driving, particularly when there are grades (using battery power to climb a grade of any length will quickly discharge any reasonably-sized battery bank) so this solution is not useful in "real-world" driving.

Hadley et al 5,283,470 shows an electric car, that is, without ICE, with regenerative braking. Hadley et al 5,406,126 is similar.

Schmidt 5,669,842 shows a hybrid drive in which either the ICE or one of several separate motors drive the accessories, depending on whether the engine is running. The engine and motors are arranged so that the engine and the mating member of the geartrain are driven at the same speed, allowing the clutch to be synchronously engaged.

Ibaraki et al 6,003,626 discloses a hybrid in which the engine normally propels the vehicle and charges the battery through a generator; if the generator fails, the engine propels the vehicle.

Takahara et al 6,009,365 discloses a hybrid with ICE and motor connected to the wheels through a continuously variable transmission (CVT). During coasting the actual torque being exerted is compared to a calculated desired torque and the actual torque adjusted accordingly.

Bower patent 6,231,135 relates to improvements in brake systems for hybrid vehicles. Although the present application is a division of an application which was a continuation-in-part of earlier applications, and which added disclosure of a new braking system to the disclosure of the parent application, no claims to that braking system are now being pursued in this application.

Soejima 5,951,118 discloses a vehicle braking system, not limited to hybrids, which includes a seating velocity reducing device for slowing the closing of a valve; this can be employed together with regenerative braking in a hybrid. Otomo et al 5,984,432 is similar. As above, no claims of the present application are directed to improvements in braking systems, although the parent was a C-I-P which added material relating thereto to the disclosure of the grandparent application.

Numazawa et al patent 5,497,941, Umebayahi et al patent 6,265,692, and Matsuda et al patent 6,357,541 all relate to improvements in HVAC systems. As in the case of the braking

systems discussed above, no claims are currently being pursued to certain new material relating to HVAC systems that was added by the parent C-I-P application to the disclosure of the parent applications.

Takahara et al patent 6,064,161 shows operating a motor/generator of a hybrid to brake a slipping wheel. This is not a feature of the claimed invention. Takahara also shows that the vehicle operating mode can be controlled responsive to accelerator pedal position and vehicle velocity, in common with many other references. See Fig. 5.

Kaiser et al 5,979,158 suggests that emissions of an ICE on starting can be reduced by spinning the ICE to a speed approximating its idle speed, activating the ignition system for about a second, and only then activating the fuel supply. This is suggested to be useful in a hybrid. No claims of the present application are directed to high-rpm starting, although the advantages of doing so are discussed in the application. Kaiser also mentions preheating of the catalyst; this step is recited in claim 77, but is not solely relied upon for patentability. Claim 77 recites, *inter alia*, that the vehicle's operating mode is selected responsive to road load, which is not shown by Kaiser.

Salecker 5,983,740 discloses a system for controlling the engine speed during shifting of an automatic transmission to smooth transition between gears; there is a brief mention that this could be useful in a hybrid.

Salecker 6,006,149 has a closely related disclosure and claims continuing to monitor operating parameters, especially temperatures of various components, for a time (the example being one second) after the engine has been shut off.

Yang patent 5,562,566 is extremely difficult to understand, but appears to disclose a power unit combining an ICE and a motor, which is stated to be useful in vehicles, ships, aircraft,



and in industrial and process equipment. The invention seems to be directed to a unit for combining the torque, but again the patent is extremely difficult to understand. Patents 5,547,433 and 5,549,524, also to Yang, appear to be directed to related inventions.

Origuchi patent 5,212,431 is directed to a serial electric hybrid vehicle wherein a generator, preferably to be driven by a gas turbine, is operated in response to monitoring of the battery's state of charge.

Antony et al 5,714,851 shows a serial hybrid with a bypass current path around the rectifiers and battery, to connect a generator driven by an ICE directly to a traction motor.

Horwinski patent 3,904,883 discloses a hybrid, wherein a single electric motor/generator is provided with separably rotatable armature and rotator, so that the unit can be operated as both motor and generator. An ICE is provided to drive the unit, and also to propel the vehicle under various conditions. Mode switching is apparently to be accomplished responsive to the battery's state of charge; see col. 5, lines 20 - 21 and col. 6, lines 64 - 66. The vehicle is intended to operate primarily as an electric car, with overnight charging from the power grid (see col. 6, lines 45 - 51) with the engine primarily provided as a range-extender, though, as noted, the engine can supply torque to the wheels; see col. 5, line 64 - col. 6 line 30.

Reichmann et al 5,851,698 and Venkatesan et al 5,856,047 are directed to nickel-metal hydride (NiMH) batteries optimized for hybrid vehicle applications.

Park 4,331,911 shows a method for equalizing the voltage across individual cells of storage batteries.

Miller et al 4,126,200 shows a vehicle having a flywheel for energy storage. Hagin et al 4,216,684 is similar. Matthews 4,591,016 shows recovering energy during regenerative braking by

accelerating a flywheel. Michel 4,592,454 shows doing so employing a hydropneumatic accumulator.

Stuhr 4,674,280 shows an accumulator for the storage of energy in a hydraulic system.

Fiala 4,416,360 shows a vehicle powertrain in which a flywheel connected to the engine by a clutch is rotated by a starter motor, and then used to start the engine using rotational inertia stored in the flywheel; the "starter" motor can then be operated as a generator to recharge the battery.

Moore 4,090,577 shows a hybrid with a conventional engine/transmission assembly driving one pair of wheels, with a solar-charged battery and motor combination driving a second pair.

Walker 5,323,688 discloses hydraulic wheel motors stated to be capable of regenerative braking.

Coe 5,384,521 discloses flywheel energy storage for a vehicle, with electromagnetic couplers.

Boll et al 5,623,194 shows a charge information system for an electric or hybrid vehicle for monitoring battery status and advising the operator.

Weiss 5,947,855 shows a hybrid drive for a tractor or the like wherein torque from an ICE is combined with torque from an electric motor, driven by a generator powered by the ICE is combined individually at the drive wheels by a "Ravigneaux" summing gear set. This is stated to provide flexibility in control.

Smith 5,971,088 shows a battery charging apparatus for regenerative charging wherein the generator is built into the vehicle driveshaft and moves with it as the vehicle encounters bumps and the like.

Walker 5,971,092 shows a hybrid comprising two ICEs, sized to accomodate differing typical loads, plus a hydraulic

accumulator. The engines are preferably two-strokes with "inertia pistons" sliding in bores in the main pistons.

Schulze et al 5,675,203 shows a motor/generator; the direction of rotation of the output shaft can be reversed by axial movement of a short-circuit winding.

Fliege 5,675,222 shows switchable winding motors for electric road vehicles.

Fliege 5,915,488 shows reducing the power supplied to switching components in a hybrid drive in response to detection of acceleration over a limiting value, e.g., to prevent sparking and erosion of switch contacts as they are jarred apart over bumps.

Lutz 5,679,087 and 5,685,798 disclose details of planetary gearboxes for vehicles.

Lutz 5,691,588 shows a clutch assembly for connecting motor and ICE of a hybrid, having separately-actuated friction plates on opposite sides of a hub forming part of the rotor.

Lutz et al patent 5,755,302 discloses a specific arrangement of a clutch connecting an engine, motor, and transmission of a hybrid - the rotor is attached to the transmission shaft and the stator to either the engine or the transmission housing, while the clutch also fits at least partially within the stator.

Fliege 5,678,646 discloses modular motors that can be stacked with interconnected coolant circuits to provide different power capacities, stated to be useful in hybrids.

Ruthlein et al 5,698,905 relates to emergency starting of a hybrid with a dead battery, by rearranging connections to allow starting by towing.

Lutz 5,713,427 shows a coupling structure for a hybrid comprising a deformable, resilient disc member.

Lutz 5,829,542 shows vehicles with separate motors on each wheel of at least one pair of wheels.

Welke patent 5,833,022 shows a specific constructional arrangement for a clutch and single traction motor of a hybrid vehicle. No operating scheme is discussed.

Adler et al 5,816,358 shows automatic disconnection of the current supply in the event of accident or the like in vehicles having relatively high current and voltage electric power supplies, e.g., hybrid vehicles.

Gardner 4,753,078 shows a hopelessly complicated hybrid vehicle design involving, among other impracticalities, "recovery of electricity from electromagnetic wind generators, gyrogenerators, and gravitational generators, and for the recovery of compressed air from air pumps...replacing the standard shock absorbers."

Wicks 5,000,003 shows a "combined cycle" engine wherein heat normally lost in the exhaust gases and rejected by heat exchange with cooling water from an ICE is recovered and used to drive a turbine or the like, and suggests that this might be especially suitable for use in a hybrid vehicle.

Lay 5,141,173 shows a vehicle capable of flight as well as travel along the ground. An ICE can propel the vehicle or drive a generator and thence electric motors, depending on the range and speed of intended travel.

Kutter 5,242,335 shows a drivetrain for a hybrid vehicle, shown in automobile and bicycle embodiments, wherein muscle power is combined with power from an auxiliary motor.

Kuang 5,264,764 shows use of an ICE as a power source to serve as a range extender for an electric car, that is, the ICE does not directly propel the vehicle.

Addie 3,699,351 shows a bi-modal vehicle, such as a rail car, which can be propelled by an external power source, such as a third rail, or by a prime mover, such as a gas turbine. A split torque device allows some of the turbine torque to be

delivered to the output shaft and the remainder to a motor/generator combination.

Shibata et al 3,719,881 shows a series hybrid, that is, an electric car comprising an ICE arranged to charge a battery connected to a traction motor, wherein the battery's state of charge is monitored and used to control operation of the ICE; the load on the ICE is monitored and the ICE is shut off when the load drops below a predetermined value.

Berman patent 3,753,059 shows a control circuit for a motor operated in both propulsive and regenerative modes, as might be employed in the hybrid vehicle drive system of Berman patent 3,566,717, already of record. Berman 3,790,816 shows an "energy storage and transfer power processor" apparently intended for use with the same system.

Williams 4,099,589 shows a series hybrid wherein the preferred power path is from an ICE to an AC generator to an AC motor, to the wheels; a rectifier, battery and DC motor are also provided as an auxiliary or additional power source.

Rowlett 4,233,858 shows a vehicle propulsion system wherein two electric motors are provided. Torque from the two motors is combined; excess torque is stored in a flywheel, to provide load-leveling.

Dailey 4,287,792 shows a variable gear ratio transmission.

Fiala 4,411,171 shows a hybrid vehicle power train in which a single electric motor/generator and an ICE are coupled to the wheels of the vehicle. Various operating modes are described.

Tankersley et al patent 5,403,244 shows an electric vehicle with a planetary gearbox for reducing the shaft speed of an electric motor to a speed suitable for driving the wheels of the vehicle, and also providing a direct drive.

Hadley et al 5,406,126 shows another serial hybrid. The invention appears to have to do with the method of regenerative charging offered.

Westphal patent 5,570,615 shows a three-mass flywheel construction, with two of the masses connected by springs and the third by planetary gears for balancing of various moments and vibrations.

Nedungadi patent 6,110,066 shows a hybrid vehicle operating in four modes, as follows (col. 4, lines 25 - 38): "There are four modes of operation for the vehicle, namely: (a) electric; (b) charge; (c) assist; and, (d) regenerative. In the electric mode, only the motor is providing propulsion power to the vehicle. In the charge mode, part of the engine power drives the vehicle and the rest is absorbed by the motor (operating as a generator) to charge the batteries. In the assist mode, both the engine and the motor are providing power to propel the vehicle. In the regenerative mode, power from the decelerating wheels is diverted to the motor so that it can be used to charge the batteries. .... The controller selects the most appropriate mode depending upon the position of the accelerator pedal, the vehicle speed and the state of charge of the battery." Nedungadi makes it clear that the idea is to keep the engine "as loaded as possible" (col. 8, line 46). In assist mode, this is done by keeping the engine at maximum power; in the charge mode, the engine is maintained at its point of maximum fuel efficiency. See col. 5, lines 46 - 53.

Fini patent 6,387,007 shows several embodiments of hybrids. Mode control appears to be accomplished responsive to accelerator pedal position.

Tsai et al 6,592,484 shows a hybrid comprising an ICE and a single motor as prime movers. The invention is directed to a

transmission including four clutches and two planetary gearsets. Some 13 operating modes are stated to be provided.

Horwinski patent 3,904,883 is essentially a predecessor of the Horwinski patent already of record.

Yamada patent 6,041,877 was recently cited in an Office Action issued against a Japanese application based on a PCT application with disclosure corresponding to the disclosures of the two parent applications. According to a non-certified translation of the Office Action, Yamada was cited because it shows "a hybrid vehicle in which a battery is configured as two separate battery sub-banks"; this was cited against a claim not corresponding to any now in this application, including a similar recitation. (Claim 29 of issued patent 6,209,672 includes a comparable limitation.) The disclosure of Yamada otherwise seems merely cumulative to numerous references of record. Japanese Utility Model Application No. 50-099456 (provided with a translated summary sheet only) was also cited in the same Office Action, the Japanese Examiner stating that "there is described a technology in which two battery groups in an electrically driven vehicle (B1 and B2, B4 and B3) are connected in series and the middle of the two battery groups is earthed to a vehicle chassis." Again, this is not relevant to any claim now being asserted herein.

Tabata patent 5,887,670 shows a single-motor hybrid. Mode determination is accomplished (see Fig. 7) responsive to a "currently required output Pd" which is determined responsive to pedal position, rate of change thereof, vehicle speed and transmission lever position (see col. 23, lines 20 - 26).

Otsu et al patent 6,123,163 shows a single-motor hybrid configured as a sort of city scooter. The vehicle operates in different modes depending on the "aimed" torque, which is determined responsive to accelerator opening and vehicle speed.

See Fig. 13, col. 10, lines 56 - 67 and col. 17, lines 11 - 33. Otsu 6,260,644 seems to have the same disclosure, and Suzuki 6,253,865 to relate to the same design.

Arai patent 6,435,296 shows a hybrid with an engine driving one set of wheels and a motor driving the other. In order that a DC motor can be used, avoiding the expense of an inverter, the motor is to be used as little as possible.

Sherman 5,789,823 shows both a torque converter and a friction clutch in a single motor hybrid. This is essentially an engine-assist arrangement; the engine can only be started when the vehicle transmission is in neutral (see col. 3, lines 30 - 38), so that it must be run at all times, and the motor/generator is stated to only assist the engine during times of peak power requirement (col. 4, lines 36 - 38). Another Sherman patent 5,258,651 is not directed to hybrid vehicles, but to a system for starting an ICE.

Onimaru 6,007,443 (Nippon Soken) shows a hybrid wherein an ICE is connected through a CVT and a clutch to a motor/generator, the output shaft of which drives the wheels. Above a minimum velocity, the engine is operated at a maximum speed. See col. 7, line 17. At lower vehicle speeds, the engine is permitted to idle; see col. 6, lines 9 - 23.

Ehsani et al, in "Propulsion System Design of Electric and Hybrid Vehicles", discuss determination of the sizes and capacities of an ICE and traction motor for a hybrid vehicle. This is generally relevant to the subject matter of claims 16 and 112. However, note that Ehsani fails entirely to address the relationship claimed between the voltage and current of the battery bank, as claimed. Ehsani et al, in "Parametric Design of the Drive Train of an Electrically Peaking Hybrid (ELPH) Vehicle", go into further detail, and indicate that the vehicle of concern is a single-motor hybrid wherein torque from the ICE



and motor can be combined by a "matchgear", as in applicant's prior patent 5,343,970. Ehsani patent 5,586,613, apparently directed to the same work, is discussed in the application as filed.

Yamaguchi et al, "Development of a New Hybrid System - Dual System", SAE paper 960231 (1996) appears to be merely cumulative to numerous patents to the same inventors already of record. "Dual System - Newly Developed Hybrid System" (publication details not known), by some of the same authors, of which only a partial copy is available, is generally cumulative but does provide a diagram showing operation of the various components as a function of time

Takaoka et al, in "A High-Expansion-Ratio Gasoline Engine for the Toyota Hybrid System", discuss the details of an ICE designed for use in a hybrid vehicle. This paper states that "By using the supplementary drive power of the electric motor, the system eliminates the light-load range, where concentrations of hydrocarbons in the emissions are high and the exhaust temperature is low." (p. 57; a similar statement is made on p. 59) and "By allocating a portion of the load to the electric motor, the system is able to reduce engine load fluctuation under conditions such as rapid acceleration. This makes it possible to reduce quick transients in engine load so that the air-fuel ratio can be stabilized easily." (p. 58). The former statement simply emphasizes the fact that engines are operated more efficiently at higher loads, and the latter that stoichiometric combustion can be more nearly obtained if the engine's speed and/or load is varied as slowly as possible.

Sasaki et al, "Toyota's Newly Developed Electric-Gasoline Hybrid Powertrain System" (publication data not available) provides a mathematical analysis of the planetary gearbox.

PCT application PCT/SE81/00280, published as WO 82/01170, shows a hybrid vehicle wherein an ICE is used for propulsion under some circumstances and an electric motor under others, e.g., to provide a forklift truck that operates electrically when indoors and is driven by the ICE when outdoors. The change from one torque source to the other is made as a function of vehicle speed. See p. 3, lines 19 - 28.

Japanese utility model publication 53-55105 (of which only a partial translation is available) appears to show a hybrid vehicle having both an ICE and a motor as sources of propulsive torque, but the description provided is inadequate to understand how the two sources are to be operated. The disclosure of Japanese patent application publication 48-64626 (of which only a partial translation is available) seems to be similar.

Japanese unexamined patent application publication 4-67703 (of which only a partial translation is available) appears to relate to an electric vehicle.

Japanese patent application publication 4-297330 (of which only a partial translation is available) seems to relate to supplementing the regenerative braking available using a traction motor as the source of braking torque with regenerative braking from a generator attached to an ICE, and with friction from motoring the engine under braking.

Japanese patent application publication 55-110328 (of which only a partial translation is available) relate to a vehicle wherein a first pair of wheels is driven by a "main driving unit", a second pair being driven by an "auxiliary power unit", wherein the auxiliary power unit is controlled responsive to a difference in speed between the first and second pairs of wheels.

Japanese utility model publication 51-103220 (of which only a partial translation is available) describes a control system for a hybrid wherein the output shaft of an ICE is connected to

that of an electric motor through a clutch, the clutch being controlled to operate when speed sensors on the shafts indicate that their rotational speeds are equal.

Japanese patent 49-29642 (of which only a partial translation is available) also shows a hybrid wherein the shaft of an ICE is connected by a clutch to that of an electric motor; in this case a one-way clutch is also provided.

Japanese patent publication 6-245317 (of which only a partial translation is available) relates to a device for preventing overcharging of the battery of an electric vehicle.

European patent application publication no. 510 582 shows a vehicle powerplant featuring both an ICE and an electric motor as sources of propulsion, and thus a hybrid of sorts, though the term is not mentioned. No suggestion is made that the control of operating mode is made other than by an operator; the determining factor seems to be whether emission must be completely prohibited, as in indoor operation.

European patent application publication no. 510 582 also shows a hybrid vehicle featuring both an ICE and an electric motor as sources of propulsion. Again there is no teaching of the specifics of switching operating mode; the invention has to do with loading the ICE by means of the generator so as to match the speed of the engine to the speed of a drive shaft driven by the traction motor before engaging a clutch connecting the two.

German OS 25 17 110, provided with an English-language abstract, is stated by the abstract to show a hybrid vehicle with a turbine engine. It appears that the vehicle is operated as an electric car until the current drawn exceeds a preset value, when the turbine is actuated; thereafter, the turbine is run at an "optimum setting", with the load split between battery charging and vehicle propulsion.

Mayrhofer et al, "A Hybrid Drive Based on a Structure Variable Arrangement" (1994), shows a hybrid vehicle design involving an ICE, two motor/generators, a planetary gearbox to enable combinations of sources of torque, and no less than four clutches, obviously much more complicated than would be desirable. Of interest with respect to the present invention is that in one operating strategy (see page 196) Mayrhofer et al suggest that the ICE should be activated only when the mean value of the power demanded exceeds a limit for more than a minimum time, 20 seconds being the example given. It is apparent that the ICE is thus to be used only for load-leveling and that mode changes are not being made based on the road load *per se*. In other strategies the engine operation appears to be even further afield from applicants' simple and direct strategy.

A December 1990 *Popular Science* article, "Diesel-Electric VW", describes a hybrid wherein an electric motor, also serving a generator and engine starter, is disposed between clutches connecting the motor to an ICE on one side and the vehicle wheels on the other. It is not clear what modes are provided, although some transitions are apparently made responsive to accelerator pedal position and vehicle velocity.

A May 1991 *Popular Science* article, "Electric Vehicles Only", addresses the then-current state of the art in electric vehicles and mentions hybrids only peripherally.

An April 1991 article appearing in *NASA Tech Briefs* discusses lead/acid batteries having woven electrodes.

As indicated, none of the newly-cited patents made of record hereby disclose or suggest the invention claimed herein. Early and favorable action on the merits of the application is earnestly solicited.

Respectfully submitted,

*May 17, 2004*  
Dated

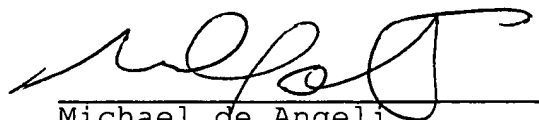

Michael de Angeli  
Reg. No. 27,869  
60 Intrepid Lane  
Jamestown, RI 02835  
401-423-3190

MAY 20 2006  
 PATENT & TRADEMARK OFFICE

OIPE 1AP87  
 JUL 07 2006  
 PATENT & TRADEMARK OFFICE

1 of 12

INFORMATION DISCLOSURE CITATION  
 IN AN APPLICATION

NUMBER PAICE201.DIV APPLICATION NUMBER 10/382,577  
 APPLICANT Severinsky et al  
 FILING DATE 3/7/2003 GROUP ART UNIT 3616

U.S. PATENT DOCUMENTS

EXAMINER INITIAL	DOCUMENT NUMBER	DATE	NAME	CLASS	SUBCLASS	FILING DATE
DD	6 2 8 1 6 6 0	08/2001	Abe			
	<del>5 5 1 5 9 3 7 5</del>	<del>5/1996</del>	<del>Adler et al</del>			<i>previously cited</i>
DD	5 3 3 6 9 3 2 4	4/1994	Barske			
DD	6 1 7 0 5 8 7 1	1/2001	Bullock			
DD	5 8 8 7 6 7 4 3	3/1999	Gray			
DD	4 7 6 2 1 9 1 8	8/88	Hagin et al			
	6 3 1 5 0 6 8 1 1	11/2001	Hoshiya et al			<i>previously cited</i>
DD	5 8 5 6 7 0 9 1	1/1999	Ibaraki et al			
DD	6 2 0 4 6 3 6 3	3/2001	Kinoshita et al			
DD	6 2 2 5 7 8 4 5	5/2001	Kinoshita et al			
DD	6 2 3 2 7 4 8 5	5/2001	Kinoshita et al			
	6 0 1 9 6 9 8 2	2/2000	Lawrie			<i>previously cited</i>

RECEIVED  
 JUN 02 2004  
 GROUP 3600

FOREIGN PATENT DOCUMENTS

DOCUMENT NUMBER	DATE	COUNTRY	CLASS	SUBCLASS	TRANSLATION	
					YES	NO

OTHER DOCUMENTS (Including Author, Title, Date, Pertinent Pages, Etc)

EXAMINER *[Signature]* DATE CONSIDERED 6/24/04

EXAMINER: Initial if citation considered, whether or not citation is in conformance with MPEP § 609; Draw line through citation if not in conformance and not considered. Include copy of this form with next communication to the applicant.

PATENT & TRADEMARK O

INFORMATION DISCLOSURE CITATION  
IN AN APPLICATION

DOCKET NUMBER PAICE201.DIV APPLICATION NUMBER 10/382,577  
 APPLICANT Severinsky et al  
 FILING DATE 3/7/2003 GROUP ART UNIT 3616

U.S. PATENT DOCUMENTS

EXAMINER INITIAL	DOCUMENT NUMBER	DATE	NAME	CLASS	SUBCLASS	FILING DATE
	5 9 9 3 3 5 0	11/1999	Lawrie et al			
	5 9 7 9 2 5 7	11/1999	Lawrie			
	6 0 0 6 6 2 0	12/1999	Lawrie et al			
DD	6 2 9 1 9 5 3	9/2001	Lovatt et al			
DD	6 3 3 2 2 5 7	12/2001	Reed Jr. et al			
DD	5 9 4 3 9 1 8	8/1999	Reed Jr. et al			
	5 7 5 5 3 0 2	5/1998	Lutz et al			on page 10
DD	6 1 4 2 9 0 7	11/2000	Minowa			
DD	6 3 2 8 6 7 0	12/2001	Minowa			
DD	6 1 1 9 7 9 9	9/2000	Morisawa			
DD	5 9 8 4 0 3 4	11/1999	Morisawa			
DD	6 3 3 4 4 9 8	1/2002	Morisawa			

RECEIVED  
 JUN 02 2004  
 GROUP 3600  
*personally cited*

FOREIGN PATENT DOCUMENTS

DOCUMENT NUMBER	DATE	COUNTRY	CLASS	SUBCLASS	TRANSLATION	
					YES	NO

OTHER DOCUMENTS (Including Author, Title, Date, Pertinent Pages, Etc)

EXAMINER *[Signature]* DATE CONSIDERED 11/24/07

EXAMINER: Initial if citation considered, whether or not citation is in conformance with MPEP §609; Draw line through citation if not in conformance and not considered. Include copy of this form with next communication to the applicant.



INFORMATION DISCLOSURE CITATION IN AN APPLICATION	DOCKET NUMBER	PAICE201.DIV	APPLICATION NUMBER	10/382,577
	APPLICANT			
	FILING DATE 3/1/2003		GROUP ART UNIT	
		3616		

U.S. PATENT DOCUMENTS

EXAMINER INITIAL	DOCUMENT NUMBER	DATE	NAME	CLASS	SUBCLASS	FILING DATE
DD	5 8 9 5 3 3 3 4	1999	Morisawa			
DD	6 3 0 6 0 5 7 10	2001	Morisawa			
DD	6 3 4 4 0 0 8 2	2002	Nagano			
DD	6 0 9 0 0 0 7 7	2000	Nakajima			
DD	6 3 2 8 6 7 1 12	2001	Nakajima			
DD	5 6 6 0 0 7 7 8	1997	Nekola			
DD	6 2 0 3 4 6 8 3	2001	Nitta			
DD	6 3 2 1 1 5 0 11	2001	Nitta			
DD	5 9 4 4 6 3 0 8	1999	Omote			
DD	6 0 7 0 6 8 0 6	2000	Oyama			
DD	6 1 2 3 6 4 2 9	2000	Saito			
DD	6 1 5 8 5 4 1 12	2000	Tabata			

RECEIVED  
JUN 02 2004  
GROUP 5600

FOREIGN PATENT DOCUMENTS

DOCUMENT NUMBER	DATE	COUNTRY	CLASS	SUBCLASS	TRANSLATION	
					YES	NO

OTHER DOCUMENTS (Including Author, Title, Date, Pertinent Pages, Etc)

DD	Published application US 2001/0037905 of Nogi et al.	11/2001

EXAMINER: *[Signature]* DATE CONSIDERED: 11/29/04

EXAMINER: Initial if citation considered, whether or not citation is in conformance with MPEP § 609; Draw line through citation if not in conformance and not considered. Include copy of this form with next communication to the applicant.





<b>INFORMATION DISCLOSURE CITATION IN AN APPLICATION</b>	DOCKET NUMBER	PAICE201.DIV	APPLICATION NUMBER	10/382,577
	APPLICANT	Severinsky et al		
	FILING DATE	3/7/2003	GROUP ART UNIT	3616

U.S. PATENT DOCUMENTS

EXAMINER INITIAL	DOCUMENT NUMBER	DATE	TITLE	CLASS	SUBCLASS	FILING DATE
DD	5 8 4 7 4 6 9	12/1998	Tabata			
DD	6 3 1 7 6 6 5	11/2001	Tabata			
DD	6 1 8 3 3 8 9	2/2001	Tabata			
DD	5 8 7 3 4 2 6	2/1999	Tabata			
DD	5 9 2 3 0 9 3	7/1999	Tabata			
DD	6 3 4 0 3 3 9	1/2002	Tabata			
DD	5 9 3 5 0 4 0	8/1999	Tabata et al.			
DD	5 4 1 5 6 0 3	5/1995	Tuzuki et al.			
DD	6 2 5 8 0 0 1	6/2001	Wakuta			
DD	5 8 9 0 4 7 0	4/1999	Woon			
DD	6 3 2 8 1 2 2	12/2001	Yamada			
DD	6 2 7 8 1 9 5	8/2001	Yamaguchi et al.			

RECEIVED  
JUN 02 2004  
GROUP 3600

FOREIGN PATENT DOCUMENTS

	DOCUMENT NUMBER	DATE	COUNTRY	CLASS	SUBCLASS	TRANSLATION	
						YES	NO
DD	4 8 6 4 6 2 6	9/1973	Japan				part.
DD	4 9 2 9 6 4 2	8/1974	Japan				"

OTHER DOCUMENTS (Including Author, Title, Date, Pertinent Pages, Etc)

DD	Published patent application US 2003/0085577 of Takaoka et al, May 8, 2003

EXAMINER: DATE CONSIDERED: 11/29/04

EXAMINER: Initial if citation considered, whether or not citation is in conformance with MPEP § 609; Draw line through citation if not in conformance and not considered. Include copy of this form with next communication to the applicant.



INFORMATION DISCLOSURE CITATION IN AN APPLICATION	DOCKET NUMBER	PAICE201.DIV	APPLICATION NUMBER	10/382,577
	APPLICANT	Severinsky et al		
	FILED DATE	3/7/2003	GROUP ART UNIT	3616

U.S. PATENT DOCUMENTS

EXAMINER INITIAL	DOCUMENT NUMBER	DATE	NAME	CLASS	SUBCLASS	FILING DATE
DD	6 2 4 7 4 3 7	6/2001	Yamaguchi et al			
DD	5 9 6 7 9 4 0	10/1999	Yamaguchi et al			
DD	5 0 8 1 3 6 5	1/1992	Field et al			
DD	6 0 4 4 9 2 2	4/2000	Field			
DD	6 4 8 1 5 1 6	11/2002	Field et al			
	3 7 1 9 8 8 1	3/1971	Shibata et al			
DD	4 1 8 7 4 3 6	2/1980	Etienne			
DD	5 7 2 2 5 0 2	3/1998	Kubo			
DD	6 2 3 1 1 3 5	5/2001	Bower et al			
DD	6 3 5 7 5 4 1	3/2002	Matsuda et al			
DD	6 2 6 5 6 9 2	7/2001	Umebayahi et al			
DD	5 4 9 7 9 4 1	3/1996	Numazawa et al			

RECEIVED  
JUN 02 2004  
GROUP 5000

Cited on pg 10

FOREIGN PATENT DOCUMENTS

	DOCUMENT NUMBER	DATE	COUNTRY	CLASS	SUBCLASS	TRANSLATION	
						YES	NO
DD	5 3 5 5 1 0 5	05/1978	Japan				part
DD	4 6 7 7 0 3	3/1992	Japan				"
DD	6 2 4 5 3 1 7	2/1993	Japan				"
DD	4 2 9 7 3 3 0	10/1992	Japan				"
DD	51 1 0 3 2 2 0	8/1976	Japan				"

OTHER DOCUMENTS (Including Author, Title, Date, Pertinent Pages, Etc)

DD	Mayrhofer et al "A Hybrid Drive Based on a Structure Variable Arrangement" (1994)

EXAMINER: *[Signature]* DATE CONSIDERED: 11/29/04

EXAMINER: Initial if citation considered, whether or not citation is in conformance with MPEP § 609; Draw line through citation if not in conformance and not considered. Include copy of this form with next communication to the applicant.



INFORMATION DISCLOSURE CITATION IN AN APPLICATION	DOCKET NUMBER	PAICE201.DIV	APPLICATION NUMBER	10/382,577
	APPLICANT	Severinsky et al		
	FILING DATE	3/7/2003	GROUP ART UNIT	3616

U.S. PATENT DOCUMENTS

EXAMINER INITIAL	DOCUMENT NUMBER	DATE	NAME	CLASS	SUBCLASS	FILING DATE
DD	6 0 6 4 1 6 1	5/2000	Takahara			
DD	5 5 6 2 5 6 6	10/1996	Yang			
DD	5 2 1 2 4 3 1	5/1993	Origuchi et al			
	4 1 6 5 7 9 5	8/1979	Lynch et al			Previously cited
DD	5 2 8 3 4 7 0	2/1994	Hadley et al			
DD	5 4 0 6 1 2 6	8/1995	Hadley et al			
DD	5 6 6 9 8 4 2	9/1997	Schmidt			
DD	5 7 7 1 4 7 8	6/1998	Tsukamoto			
DD	5 8 3 3 5 7 0	11/1998	Tabata			
DD	5 9 5 1 6 1 4	9/1999	Tabata			
DD	5 8 7 5 6 9 1	3/1999	Hata			
DD	5 9 3 1 2 7 1	8/1999	Haka			

RECEIVED  
JUN 02 2004  
GROUP 3600

FOREIGN PATENT DOCUMENTS

	DOCUMENT NUMBER	DATE	COUNTRY	CLASS	SUBCLASS	TRANSLATION	
						YES	NO
DD	5 1 0 5 8 2	10/1992	European Patent Office				
DD	1 3 6 0 5 5	3/1985	European Patent Office				
DD	2 5 1 7 1 1 0	10/1975	German				
DD	8 2 0 1 1 7 0	4/1982	PCT/SE81/00280				
DD	55 1 1 0 3 2 8	8/1980	Japan				part

OTHER DOCUMENTS (Including Author, Title, Date, Pertinent Pages, Etc)

DD	"Diesel-Electric VW", <i>Popular Science</i> , December 1990, p. 30.
DD	"Electric Vehicles Only", <i>Popular Science</i> , May 1991, pp. 76-81 and 110.
DD	"Lightweight, High-Energy Lead/Acid Battery" <i>NASA Tech Briefs</i> , 4/91, 22-24.

EXAMINER DATE CONSIDERED 11/29/04

EXAMINER: Initial if citation considered, whether or not citation is in conformance with MPEP §609; Draw line through citation if not in conformance and not considered. Include copy of this form with next communication to the applicant.



INFORMATION DISCLOSURE CITATION IN AN APPLICATION	DOCKET NUMBER	PAICB201.DIV	APPLICATION NUMBER	10/382,577
	APPLICANT			
	FILING DATE 3/7/2003		EXAMINER ART UNIT	

U.S. PATENT DOCUMENTS

EXAMINER INITIAL	DOCUMENT NUMBER	DATE	NAME	CLASS	SUBCLASS	FILING DATE
DD	5 9 5 1 1 1 8	9/1999	Soejima			
DD	5 9 8 4 4 3 2	11/1999	Otomo et al			
DI	5 9 7 9 1 5 8	11/1999	Kaiser			
DD	5 9 8 3 7 4 0	11/1999	Salecker et al			
DD	6 0 0 6 1 4 9	12/1999	Salecker et al			
DD	6 0 0 3 6 2 6	12/1999	Ibaraki et al			
DD	6 0 0 9 3 6 5	12/1999	Takahara et al			
DD	4 1 2 6 2 0 0	11/1978	Miller et al			
DD	4 0 9 0 5 7 7	5/1978	Moore			
DD	5 3 2 3 6 8 8	6/1994	Walker			
DI	5 3 8 4 5 2 1	1/1995	Coe			
DD	5 6 2 3 1 9 4	4/1997	Boll			

RECEIVED  
JUN 02 2004  
GROUP 6000

FOREIGN PATENT DOCUMENTS

DOCUMENT NUMBER	DATE	COUNTRY	CLASS	SUBCLASS	TRANSLATION	
					YES	NO

OTHER DOCUMENTS (Including Author, Title, Date, Pertinent Pages, Etc)

EXAMINER *[Signature]* DATE CONSIDERED 11/29/09

EXAMINER: Initial if citation considered, whether or not citation is in conformance with MPEP § 609; Draw line through citation if not in conformance and not considered. Include copy of this form with next communication to the applicant.



INFORMATION DISCLOSURE CITATION  
IN AN APPLICATION

DOCKET NUMBER PAICE201.DIV APPLICATION NUMBER 10/382,577  
 APPLICANT Severinsky et al  
 FILING DATE 3/7/03 GROUP ART UNIT 3616

U.S. PATENT DOCUMENTS

EXAMINER INITIAL	DOCUMENT NUMBER	DATE	NAME	CLASS	SUBCLASS	FILING DATE
DD	5 6 7 5 2 0 3	10/1997	Schulze et al			
DD	5 6 7 5 2 2 2	10/1997	Fliege			
DD	5 6 7 9 0 8 7	10/1997	Lutz			
DD	5 6 8 5 7 9 8	11/1997	Lutz			
DD	5 6 9 1 5 8 8	11/1997	Lutz			
DD	5 6 9 8 9 0 5	12/1997	Ruthlein et al			
DD	5 7 1 3 4 2 7	2/1998	Lutz			
DD	5 7 1 4 8 5 1	2/1998	Antony et al			
DD	5 8 5 6 0 4 7	1/1999	Venkatesan et al			
DD	5 8 5 1 6 9 8	12/1998	Reichmann et al			
DD	4 2 1 6 6 8 4	8/1980	Hagin et al			
DD	4 3 3 1 9 1 1	5/1982	Park			

RECEIVED  
 JUN 02 2004  
 GROUP 6600

FOREIGN PATENT DOCUMENTS

DOCUMENT NUMBER	DATE	COUNTRY	CLASS	SUBCLASS	TRANSLATION	
					YES	NO

OTHER DOCUMENTS (Including Author, Title, Date, Pertinent Pages, Etc)

EXAMINER *[Signature]* DATE CONSIDERED 4/29/04

EXAMINER: Initial if citation considered, whether or not citation is in conformance with MPEP § 609; Draw line through citation if not in conformance and not considered. Include copy of this form with next communication to the applicant.



<b>INFORMATION DISCLOSURE CITATION IN AN APPLICATION</b>	DOCKET NUMBER	PAICE201.DIV	APPLICATION NUMBER	10/382,577
	APPLICANT	Severinsky et al		
	FILING DATE 3/7/03	GROUP ART UNIT	3616	

**U. S. PATENT DOCUMENTS**

EXAMINER INITIAL	DOCUMENT NUMBER	DATE	NAME	CLASS	SUBCLASS	FILING DATE
DD	4 4 1 6 3 6 0	11/1983	Fiala			
DD	4 5 9 1 0 1 6	5/1986	Matthews			
DD	4 5 9 2 4 5 4	6/1986	Michel			
DD	4 6 7 4 2 8 0	6/1987	Stuhr			
DD	4 7 5 3 0 7 8	6/1988	Gardner			
DD	5 0 0 0 0 0 3	3/1991	Wicks			
DD	5 1 4 1 1 7 3	8/1992	Lay			
DD	5 2 4 2 3 3 5	9/1993	Kutter			
DD	5 2 6 4 7 6 4	11/1993	Kuang			
DD	5 9 1 5 4 8 8	6/1999	Fliege			
DD	5 9 4 7 8 5 5	9/1999	Weiss			
DD	5 9 7 1 0 8 8	10/1999	Smith			

RECEIVED  
JUN 02 2004  
GROUP 3600

**FOREIGN PATENT DOCUMENTS**

DOCUMENT NUMBER	DATE	COUNTRY	CLASS	SUBCLASS	TRANSLATION	
					YES	NO

**OTHER DOCUMENTS** (Including Author, Title, Date, Pertinent Pages, Etc)

EXAMINER WMM DATE CONSIDERED 11/29/04

EXAMINER: Initial if citation considered, whether or not citation is in conformance with MPEP §609; Draw line through citation if not in conformance and not considered. Include copy of this form with next communication to the applicant.



<b>INFORMATION DISCLOSURE CITATION IN AN APPLICATION</b>	DOCKET NUMBER	PAICE201.DIV	APPLICATION NUMBER	10/382,577
	APPLICANT			
	FILING DATE 3/7/03		GROUP ART UNIT	

**U. S. PATENT DOCUMENTS**

EXAMINER INITIAL	DOCUMENT NUMBER	DATE	NAME	CLASS	SUBCLASS	FILING DATE
DD	5 9 7 1 0 9 2	10/1999	Walker			
DD	5 7 5 5 3 0 2	5/1998	Lutz			
DD	5 6 7 8 6 4 6	10/1997	Fliege			
	5 8 3 3 0 2 2	11/1998	Welke			pre cited
DD	5 8 1 6 3 5 8	10/1998	Adler et al			
DD	3 6 9 9 3 5 1	10/1972	Addie			
DD	3 7 1 9 8 8 1	3/1973	Shibata et al			
DD	3 7 5 3 0 5 9	8/1973	Berman			
DD	3 7 9 0 8 1 6	2/1974	Berman			
DD	4 0 9 9 5 8 9	7/1978	Williams			
DD	4 2 3 3 8 5 8	11/1980	Rowlett			
DD	4 2 8 7 7 9 2	9/1981	Dailey			

RECEIVED  
JUN 02 2004  
GROUP 5000

**FOREIGN PATENT DOCUMENTS**

DOCUMENT NUMBER	DATE	COUNTRY	CLASS	SUBCLASS	TRANSLATION	
					YES	NO

**OTHER DOCUMENTS** (including Author, Title, Date, Pertinent Pages, Etc)

EXAMINER <i>[Signature]</i>	DATE CONSIDERED <i>11/29/04</i>	<small>EXAMINER: Initial if citation considered, whether or not citation is in conformance with MPEP § 609; Draw line through citation if not in conformance and not considered. Include copy of this form with next communication to the applicant.</small>
-----------------------------	---------------------------------	--



INFORMATION DISCLOSURE CITATION IN AN APPLICATION	DOCKET NUMBER PAICE201.DIV	APPLICATION NUMBER 10/382,577
	APPLICANT Severinsky et al	
	FILED DATE 3/7/03	GROUP AND UNIT 3616

U.S. PATENT DOCUMENTS

EXAMINER INITIAL	DOCUMENT NUMBER	DATE	NAME	CLASS	SUBCLAS	FILING DATE
DD	4 4 1 1 1 7 1	10/1983	Fiala			
DD	5 4 0 3 2 4 4	4/1995	Tankersley			
	5 4 0 6 1 2 6	4/1995	Hadley et al			
DD	5 5 4 9 5 2 4	8/1996	Yang			
DD	5 5 4 7 4 3 3	8/1996	Yang			
DD	5 5 7 0 6 1 5	11/1996	Westphal et al			
DD	5 9 1 5 4 8 9	6/1999	Yamaguchi			
DD	6 1 1 0 0 6 6	8/2000	Nedungadi et al			
DD	6 1 3 5 9 1 4	10/2000	Yamaguchi et al			
DD	6 3 8 7 0 0 7	5/2002	Fini			
DD	6 5 6 3 2 3 0	5/2003	Nada			
DD	6 5 9 2 4 8 4	7/2003	Tsai			

RECEIVED  
JUN 02 2004  
GROUP 5600

Cited on pg 6

FOREIGN PATENT DOCUMENTS

DOCUMENT NUMBER	DATE	COUNTRY	CLASS	SUBCLASS	TRANSLATION	
					YES	NO

OTHER DOCUMENTS (Including Author, Title, Date, Pertinent Pages, Etc)

- DD Yamaguchi et al, "Dual System - Newly Developed Hybrid System" (incomplete)
- DD Takaoka et al "A High-Expansion-Ratio Gasoline Engine for the Toyota Hybrid System", Toyota Technical Review 47, 2, 1998 Vol. 47, No. 2, April 1998.
- DD Sasaki et al, "Toyota's Newly Developed Electric-Gasoline Hybrid Powertrain System" (publication data not available)

EXAMINER: *[Signature]* DATE CONSIDERED: 11/29/04

EXAMINER: Initial if citation considered, whether or not citation is in conformance with MPEP §609; Draw line through citation if not in conformance and not considered. Include copy of this form with next communication to the applicant.





INFORMATION DISCLOSURE CITATION IN AN APPLICATION	DOCKET NUMBER	PAICE201.DIV	APPLICATION NUMBER	10/382,577
	APPLICANT	Severinsky et al		
	FILING DATE	3/7/03	GROUP ART UNIT	3616

**U.S. PATENT DOCUMENTS**

EXAMINER INITIAL	DOCUMENT NUMBER	DATE	NAME	CLASS	SUBCLAS	FILING DATE
DD	3 9 0 4 8 8 3	9/1975	Horwinski			
DD	6 0 4 1 8 7 7	3/2000	Yamada et al			
	<del>5 8 8 7 6 7 0</del>	<del>3/1999</del>	<del>Tabata et al</del>			
DD	6 1 2 3 1 6 3	9/2000	Otsu et al			
DD	6 2 6 0 6 4 4	7/2001	Otsu			
DD	6 2 5 3 8 6 5	7/2001	Suzuki			
DD	6 4 3 5 2 9 6	8/2002	Arai			
DD	5 2 5 8 6 5 1	11/1993	Sherman			
DD	5 7 8 9 8 2 3	8/1998	Sherman			
DD	6 0 0 7 4 4 3	12/1999	Onimaru			

RECEIVED

JUN 02 2004

prev. cited

GROUP 3600

**FOREIGN PATENT DOCUMENTS**

DOCUMENT NUMBER	DATE	COUNTRY	CLASS	SUBCLASS	TRANSLATION	
					YES	NO
50 0 9 9 4 5 6	1/1977	Japan				

NOT SUBMITTED

**OTHER DOCUMENTS** (Including Author, Title, Date, Pertinent Pages, Etc)

DD	Ehsani et al "Propulsion System Design of Electric and Hybrid Vehicles", IEEE Trans. Ind. Elec., 44 1 (1997)
DD	Ehsani et al, "Parametric Design of the Drive Train of an Electrically Peaking Hybrid (ELPH) Vehicle", SAE paper 970294 (1997)
DD	Yamaguchi et al, "Development of a New Hybrid System - Dual System", SAE papers 960231 (1996)

EXAMINER: *[Signature]* DATE CONSIDERED: 11/29/04

EXAMINER: Initial if citation considered, whether or not citation is in conformance with MPEP §609; Draw line through citation if not in conformance and not considered. Include copy of this form with next communication to the applicant.



IN THE UNITED STATES PATENT AND TRADEMARK OFFICE

In re the Patent Application of :  
Severinsky et al : Examiner: N/A  
Serial No.: N/A : Group Art Unit: N/A  
Filed: Herewith : Att. Dkt.: PAICE201.DIV  
For: HYBRID VEHICLES :

Hon. Commissioner of Patents and Trademarks  
Washington, DC 20231

**INFORMATION DISCLOSURE STATEMENT**

Dear Sir:

This application is a divisional of Ser. No. 09/822,866. Incorporated herein by this reference are the original and three supplemental Information Disclosure Statements filed in the parent, copies of which are enclosed herewith. These, together with an Examiner's Notice of References Cited, a copy of which is also enclosed, collectively list all of the art deemed relevant to the claims of the application. Copies of the references were provided in the parent or in the applications from which it in turn claimed priority and thus are not being provided herewith. The Examiner is requested to indicate that all of the art thus listed has been considered.

Early and favorable action on the merits is earnestly solicited.

Respectfully submitted,

Michael de Angeli  
Reg. No. 27,869  
60 Intrepid Lane  
Jamestown, RI 02835  
401-423-3190

3/5/03  
Dated

**BEST AVAILABLE COPY**



IN THE UNITED STATES PATENT AND TRADEMARK OFFICE

In re the Patent Application of	:
Severinsky et al	:
Serial No.: 09/822,866	: Examiner: N/A
Filed: April 2, 2001	: Group Art Unit: N/A
	: Att. Dkt.: PAICE201
For: Hybrid Vehicles	:

Hon. Commissioner of Patents and Trademarks  
Washington, DC 20231

**INFORMATION DISCLOSURE STATEMENT**

Dear Sir:

Listed on attached PTO-1449 forms are the issued patents and literature references considered to be most relevant to the patentability of the claims of this application. Copies of the patents listed on page 15 of the PTO-1449 are attached for the convenience of the Examiner, as is a copy of German patent 1,905,641, with uncertified translation. Copies of the other listed references were provided to the Examiner in connection with one or both of patent applications 09/264,817 and 09/392,743, so additional copies are not being submitted herewith.

Comments on the relevance of the new references which are material to the claims of this continuation-in-part per se are found in the application as filed, while the comments on these references found in the prosecution files of the two parent applications are also incorporated by reference herein.

Early and favorable action on the merits is earnestly solicited.

5/21/01  
Dated

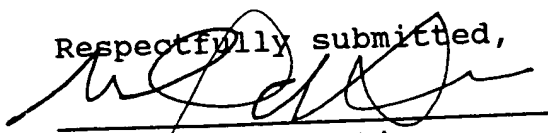
Respectfully submitted,  
  
Michael de Angeli  
Reg. No. 27,869  
Suite 330  
1901 Research Blvd.  
Rockville, MD 20850  
(301) 217-9585



**INFORMATION DISCLOSURE CITATION  
IN AN APPLICATION**

DOCKET NUMBER: PAICE201 APPLICATION NUMBER: 09/822,866  
 APPLICANT: Severinsky et al  
 FILING DATE: 04/02/01 GROUP ART UNIT: N/A 3616

JP498 U.S. PTO  
 10/382577  
 03/07/03

**U. S. PATENT DOCUMENTS**

EXAMINER INITIAL	DOCUMENT NUMBER	DATE	NAME	CLASS	SUBCLASS	FILING DATE
DD	5 3 4 3 9 7 0	9/94	Severinsky	180	65.2	
	5 4 9 2 1 9 2	2/96	Brooks et al			
	3 5 6 6 7 1 7	3/71	Berman et al			
	3 7 3 2 7 5 1	5/73	Berman et al			
	4 1 6 5 7 9 5	8/79	Lynch et al			
	5 1 1 7 9 3 1	6/92	Nishida			
	3 9 2 3 1 1 5	12/75	Helling			
	4 5 8 8 0 4 0	5/86	Albright, Jr., et al			
	5 3 1 8 1 4 2	6/94	Bates et al			
	5 1 2 0 2 8 2	6/92	Fjällström			
	4 4 0 5 0 2 9	9/83	Hunt			
	4 4 7 0 4 7 6	9/84	Hunt			
DD	4 3 0 5 2 5 4	12/81	Kawakatsu			

**FOREIGN PATENT DOCUMENTS**

	DOCUMENT NUMBER	DATE	COUNTRY	CLASS	SUBCLASS	TRANSLATION	
						YES	NO
DD	1 9 0 5 6 4 1	6/76	Germany			X	

**OTHER DOCUMENTS (Including Author, Title, Date, Pertinent Pages, Etc)**

DD	Simanaitis, "Electric Vehicles", Road & Track, May 1992, pp. 126-136
DD	Reynolds, "AC Propulsion CRX", Road & Track, Oct. 1992, pp. 126-129
DD	Kalberlah, "Electric Hybrid Drive Systems...", SAE Paper No. 910247, 1991
DD	Bullock, "The Technological Constraints of Mass, Volume, Dynamic Power Range and Energy Capacity..." SAE Paper No. 891659 1989
DD	Electric and Hybrid Vehicle Technology, vol. SP-915, SAE, Feb. 1992

EXAMINER: [Signature] DATE CONSIDERED: 11/19/04

EXAMINER: Initial if citation considered, whether or not citation is in conformance with MPEP 5609; Draw line through citation if not in conformance and not considered. Include copy of this form with next communication to the applicant.

<b>INFORMATION DISCLOSURE CITATION IN AN APPLICATION</b>	DOCKET NUMBER	PAICE201	APPLICATION NUMBER	09/822 866
	APPLICANT	Severinsky et al		
	FILING DATE	06/02/01	GROUP ART UNIT	N/A

**U. S. PATENT DOCUMENTS**

EXAMINER INITIAL	DOCUMENT NUMBER	DATE	NAME	CLASS	SUBCLASS	FILING DATE
DD	4 4 0 7 1 3 2	10/83	Kawakatsu			
	4 3 3 5 4 2 9	6/82	Kawakatsu			
	4 1 8 0 1 3 8	12/19 <sup>79</sup>	Shea			
	4 3 5 1 4 0 5	9/82	Fields et al			
	4 4 3 8 3 4 2	3/84	Kenyon			
	4 5 9 3 7 7 9	6/86	Krohling			
	4 9 2 3 0 2 5	5/90	Ellers			
	3 7 9 1 4 7 3	2/74	Rosen			
	4 2 6 9 2 8 0	5/81	ROSEN			
	4 4 0 0 9 9 7	8/83	Fiala			
	4 6 9 7 6 6 0	10/87	Wu et al			
	3 9 7 0 1 6 3	7/76	Kinoshita			
DD	4 0 9 5 6 6 4	6/78	Bray			

**FOREIGN PATENT DOCUMENTS**

DOCUMENT NUMBER	DATE	COUNTRY	CLASS	SUBCLASS	TRANSLATION	
					YES	NO

**OTHER DOCUMENTS** (Including Author, Title, Date, Pertinent Pages, Etc)

DD	Wouk, "Hybrids: Then and Now", IEEE Spectrum, Vol. 32, 7, July 1995
DD	Bates, "Getting a Ford HEV on...", IEEE Spectrum, Vol. 32, 7, July 1995
DD	King et al, "Transit Bus takes...", IEEE Spectrum, Vol. 32, 7, July 1995
DD	Yamaguchi, "Toyota readies gasoline/electric hybrid system", Automotive Engineering, July 1997, pp. 55-58
DD	Wilson, "Not Electric, Not Gasoline..." Autoweek, June 2, 1997, pp. 17-18

EXAMINER	<i>[Signature]</i>	DATE CONSIDERED	11/19/04
----------	--------------------	-----------------	----------

EXAMINER: Initial if citation considered, whether or not citation is in conformance with MPEP §609; Draw line through citation if not in conformance and not considered. Include copy of this form with next communication to the applicant.

<b>INFORMATION DISCLOSURE CITATION IN AN APPLICATION</b>	DOCKET NUMBER	PAICE201	APPLICATION NUMBER	09/822,866 10/382577
	APPLICANT			
	Severinsky et al			
FILING DATE		04/02/01	GROUP ART UNIT	
		N/A		

**U. S. PATENT DOCUMENTS**

EXAMINER INITIAL	DOCUMENT NUMBER	DATE	NAME	CLASS	SUBCLASS	FILING DATE	
						YES	NO
DD	4 1 4 8 1 9 2	4/79	Cummings				
	4 3 0 6 1 5 6	12/81	Monaco et al				
	4 3 1 3 0 8 0	11/82	Park				
	4 3 5 4 1 4 4	10/82	McCarthy				
	4 5 3 3 0 1 1	8/85	Heidemeyer				
	4 9 5 1 7 6 9	8/90	Kawamura				
	5 0 5 3 6 3 2	10/91	Suzuki et al				
	3 5 2 5 8 7 4	8/70	Toy				
	3 6 5 0 3 4 5	8/72	Yardney				
	3 8 3 7 4 1 9	9/74	Nakamura				
	3 8 7 4 4 7 2	4/75	Deane				
	4 0 4 2 0 5 6	8/77	Horwinski				
DD	4 5 6 2 8 9 4	1/86	Yang				

**FOREIGN PATENT DOCUMENTS**

DOCUMENT NUMBER	DATE	COUNTRY	CLASS	SUBCLASS	TRANSLATION	
					YES	NO

**OTHER DOCUMENTS** (Including Author, Title, Date, Pertinent Pages, Etc)

DD	Bulgin, "The Future Works, Quietly", Autoweek, Feb. 23, 1998 pp. 12-13
DD	"Toyota Electric and Hybrid Vehicles", a Toyota brochure
DD	Nagasaka et al, "Development of the Hybrid/Battery ECU...", SAE paper 981122, 1998, pp. 19-27

EXAMINER: DD DATE CONSIDERED: 11/19/04

EXAMINER: Initial if citation considered, whether or not citation is in conformance with MPEP 5609; Draw line through citation if not in conformance and not considered. Include copy of this form with next communication to the applicant.

<b>INFORMATION DISCLOSURE CITATION IN AN APPLICATION</b>	DOCKET NUMBER	PAICE201	APPLICATION NUMBER	09/822-866
	APPLICANT			
	Severinsky et al			
FILING DATE			GROUP ART UNIT	
04/02/01			N/A	

**U. S. PATENT DOCUMENTS**

EXAMINER INITIAL	DOCUMENT NUMBER	DATE	NAME	CLASS	SUBCLASS	FILING DATE
DD	4 6 1 1 4 6 6	9/86	Keedy			
	4 8 1 5 3 3 4	3/89 <del>8/85</del>	Lexen			
	3 6 2 3 5 6 8	11/71	Mori			
	3 4 5 4 1 2 2	7/69 <del>8/65</del>	Grady, Jr.			
	3 2 1 1 2 4 9	10/65	Papst			
	2 6 6 6 4 9 2	1/54	Nims et al			
	3 5 0 2 1 6 5	3/70	Matsukata			
	1 8 2 4 0 1 4	9/31	Froelich			
	3 8 8 8 3 2 5	6/75 <del>10/75</del>	Reinbeck			
	4 5 7 8 9 5 5	4/86	Medina			
	4 7 6 5 6 5 6	8/88	Weaver			
	4 4 3 9 9 8 9	4/84	Yamakawa			
	DD	5 3 0 1 7 6 4	4/94	Gardner		

**FOREIGN PATENT DOCUMENTS**

DOCUMENT NUMBER	DATE	COUNTRY	CLASS	SUBCLASS	TRANSLATION	
					YES	NO

**OTHER DOCUMENTS** (Including Author, Title, Date, Pertinent Pages, Etc)

EXAMINER [Signature] DATE CONSIDERED 11/19/04

EXAMINER: Initial if citation considered, whether or not citation is in conformance with MPEP §609; Draw line through citation if not in conformance and not considered. Include copy of this form with next communication to the applicant.

<b>INFORMATION DISCLOSURE CITATION IN AN APPLICATION</b>	DOCKET NUMBER	PAICE201	APPLICATION NUMBER	09/822,866
	APPLICANT			
	Severinsky et al			
FILING DATE			GROUP ART UNIT	
01/02/01			N/A	

**U.S. PATENT DOCUMENTS**

EXAMINER INITIAL	DOCUMENT NUMBER	DATE	NAME	CLASS	SUBCLASS	FILING DATE	
						YES	NO
D	5 3 4 6 0 3 1	9/94	Gardner				
	5 6 6 7 0 2 9	9/97	Urban et al				
	5 7 0 4 4 4 0	1/98	Urban et al				
	5 4 9 5 9 0 6	3/96	Furutani				
	5 8 4 2 5 3 4	12/98	Frank	180	65.2		
	5 8 2 3 2 8 0	10/98	Lateur	180	65.2		
	5 8 2 6 6 7 1	10/98	Nakae et al				
	5 8 4 6 1 5 5	12/98	Taniguchi et al				
	5 8 4 5 7 3 1	12/98	Buglione et al	180	65.2		
	5 5 8 6 6 1 3	12/96	Ehsani				
	5 6 3 5 8 0 5	6/97	Ibaraki et al				
	5 2 4 9 6 3 7	10/93	Heidl et al				
	D	5 5 5 8 5 8 8	9/96	Schmidt			

**FOREIGN PATENT DOCUMENTS**

DOCUMENT NUMBER	DATE	COUNTRY	CLASS	SUBCLASS	TRANSLATION	
					YES	NO

**OTHER DOCUMENTS** (Including Author, Title, Date, Pertinent Pages, Etc.)

EXAMINER	<i>[Signature]</i>	DATE CONSIDERED	11/19/04
<small>EXAMINER: Initial if citation considered, whether or not citation is in conformance with MPEP §609; Draw line through citation if not in conformance and not considered. Include copy of this form with next communication to the applicant.</small>			



**INFORMATION DISCLOSURE CITATION  
IN AN APPLICATION**

DOCKET NUMBER **PAICE201**

APPLICATION NUMBER **09/822,866**

APPLICANT **Severinsky et al**

FILING DATE **04/02/01**

GROUP ART UNIT **N/A**

**U.S. PATENT DOCUMENTS**

EXAMINER INITIAL	DOCUMENT NUMBER	DATE	NAME	CLASS	SUBCLASS	FILING DATE
<i>DD</i>	5 5 5 8 5 9 5	9/96	Schmidt et al			
	5 9 0 8 0 7 7	6/99	Moore			
	5 7 2 2 9 1 1	3/98	Ibaraki et al			
	5 7 8 9 8 8 2	8/98	Ibaraki et al			
	5 5 5 0 4 4 5	8/96	Nii			
	5 6 5 0 9 3 1	7/97	Nii			
	5 8 6 5 2 6 3	2/99	Yamaguchi et al			
	5 7 8 8 0 0 6	8/98	Yamaguchi et al			
	5 7 9 1 4 2 7	8/98	Yamaguchi et al			
	5 7 9 9 7 4 4	9/98	Yamaguchi et al			
	5 8 0 6 6 1 7	9/98	Yamaguchi et al			
	5 8 9 9 2 8 6	5/99	Yamaguchi et al			
<i>DD</i>	5 4 3 3 2 8 2	7/95	Moroto et al			

**FOREIGN PATENT DOCUMENTS**

DOCUMENT NUMBER	DATE	COUNTRY	CLASS	SUBCLASS	TRANSLATION	
					YES	NO

**OTHER DOCUMENTS** (Including Author, Title, Date, Pertinent Pages, Etc)

EXAMINER *[Signature]* DATE CONSIDERED **12/19/04**

EXAMINER: Initial if citation considered, whether or not citation is in conformance with MPEP §609; Draw line through citation if not in conformance and not considered. Include copy of this form with next communication to the applicant.

<b>INFORMATION DISCLOSURE CITATION IN AN APPLICATION</b>	DOCKET NUMBER	PAICE201	APPLICATION NUMBER	09/822,866
	APPLICANT			
	Severinsky et al			
FILING DATE			GROUP ART UNIT	
04/02/01			N/A	

**U.S. PATENT DOCUMENTS**

EXAMINER INITIAL	DOCUMENT NUMBER	DATE	NAME	CLASS	SUBCLASS	FILING DATE
DD	5 7 7 8 3 2 6	7/98	Moroto et al			
	5 7 7 5 4 4 9	7/98	Moroto et al			
	5 6 9 7 4 6 6	12/97	Moroto et al	180	65.2	
	5 6 0 8 3 0 8	3/97	Kiuchi et al			
	5 6 1 4 8 0 9	3/97	Kiuchi et al			
	5 6 2 1 3 0 4	4/97	Kiuchi et al			
	5 8 9 3 8 9 5	4/99	Ibaraki			
	5 6 5 6 9 2 1	8/97	Farrall			
	5 7 7 3 9 0 4	6/98	Schiebold et al			
	5 5 1 5 9 3 7	5/96	Adler et al			
	5 6 5 0 7 1 3	7/97	Takeuchi et al			
	5 6 3 2 3 5 2	5/97	<del>Jeanneret</del> Jeanneret et al			
DD	5 4 9 2 1 8 9	2/96	Kreigler et al			

**FOREIGN PATENT DOCUMENTS**

DOCUMENT NUMBER	DATE	COUNTRY	CLASS	SUBCLASS	TRANSLATION	
					YES	NO

**OTHER DOCUMENTS** (Including Author, Title, Date, Pertinent Pages, Etc)

EXAMINER DATE CONSIDERED 11/19/04

EXAMINER: Initial if citation considered, whether or not citation is in conformance with MPSP §609; Draw line through citation if not in conformance and not considered. Include copy of this form with next communication to the applicant.

<b>INFORMATION DISCLOSURE CITATION IN AN APPLICATION</b>	DOCKET NUMBER	PAICE201	APPLICATION NUMBER	09/822,866
	APPLICANT			
	Severinsky et al			
FILING DATE			GROUP ART UNIT	
01/02/01			N/A	

U. S. PATENT DOCUMENTS						
EXAMINER INITIAL	DOCUMENT NUMBER	DATE	NAME	CLASS	SUBCLASS	FILING DATE
DD	4 3 5 4 1 4 4	10/82	McCarthy			
	4 6 9 7 6 6 0	10/87	Wu et al			
	5 8 3 1 3 4 1	11/98	Selfors et al			
	5 4 9 5 9 0 7	3/96	Data			
	5 6 7 2 9 2 0	9/97	Donegan et al			
	5 8 2 6 6 7 1	10/98	Nakae et al			
	5 7 5 7 1 5 1	5/98	Donegan et al			
	6 0 1 8 6 9 4	1/00	Egami et al	701	102	
	5 9 9 3 3 5 1	11/99	Deguchi et al	477	5	
	5 5 6 8 0 2 3	10/96	Grayer et al			
	5 8 9 0 5 5 5	4/99	Miller			
	5 1 7 2 7 8 4	12/92	Varela, Jr.			
DD	4 4 4 4 2 8 5	4/84	Stewart et al			

FOREIGN PATENT DOCUMENTS							
DOCUMENT NUMBER	DATE	COUNTRY	CLASS	SUBCLASS	TRANSLATION		
					YES	NO	

OTHER DOCUMENTS (Including Author, Title, Date, Pertinent Pages, Etc)	

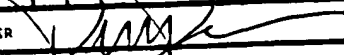
EXAMINER		DATE CONSIDERED	11/19/09
----------	---	-----------------	----------

EXAMINER: Initial if citation considered, whether or not citation is in conformance with MPEP §609; Draw line through citation if not in conformance and not considered. Include copy of this form with next communication to the applicant.

**INFORMATION DISCLOSURE CITATION  
IN AN APPLICATION**

DOCKET NUMBER **PAICE201** APPLICATION NUMBER **09/822,866**  
 APPLICANT **Severinsky et al**  
 FILING DATE **04/02/01** GROUP ART UNIT **N/A**

**U.S. PATENT DOCUMENTS**

EXAMINER INITIAL	DOCUMENT NUMBER	DATE	NAME	CLASS	SUBCLASS	FILING DATE
DD	4 5 6 2 8 9 4	1/86	Yang			
	4 4 9 5 4 5 1	1/85	Barnard			
	4 5 8 3 5 0 5	4/86	Frank et al			
	4 5 9 7 4 6 3	7/86	Barnard			
	5 7 8 9 8 8 1	8/98	Egami et al			
	5 7 8 6 6 4 0	7/98	Sakai et al			
	5 1 7 6 2 1 3	1/93	Kawai et al			
	5 8 3 9 5 3 0	11/98	Dietzel			
	5 8 9 8 2 8 2	4/99	Drozdz et al			
	5 3 2 7 9 8 7	7/94	Abdelmalek			
	5 4 1 5 2 4 5	5/95	Hammond			
	5 7 0 5 8 5 9	1/98	Karg et al			
DD	5 7 1 3 4 2 5	2/98	Buechhaus et al			

**FOREIGN PATENT DOCUMENTS**

DOCUMENT NUMBER	DATE	COUNTRY	CLASS	SUBCLASS	TRANSLATION	
					YES	NO

**OTHER DOCUMENTS** (Including Author, Title, Date, Pertinent Pages, Etc)

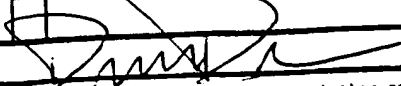
EXAMINER  DATE CONSIDERED **11/19/04**  
 EXAMINER: Initial if citation considered, whether or not citation is in conformance with MPEP §609: Draw line through citation if not in conformance and not considered. Include copy of this form with next communication to the applicant.

<b>INFORMATION DISCLOSURE CITATION IN AN APPLICATION</b>	DOCKET NUMBER <b>PAICE201</b>	APPLICATION NUMBER <b>09/822,866</b>
	APPLICANT <b>Severinsky et al</b>	
	FILING DATE 04/02/01	GROUP ART UNIT <b>N/A</b>

**U.S. PATENT DOCUMENTS**

EXAMINER INITIAL	DOCUMENT NUMBER	DATE	NAME	CLASS	SUBCLASS	FILING DATE	
						YES	NO
DD	5 8 2 0 1 7 2	10/98	Brigham et al				
	5 7 1 3 4 2 6	2/98	Okamura				
	5 7 1 3 8 1 4	2/98	Hara et al				
	5 8 2 3 2 8 1	10/98	Yamaguchi et al				
	5 4 2 7 1 9 6	6/95	Yamaguchi et al				
	5 8 3 9 5 3 3	11/98	Mikami et al				
	5 7 2 5 0 6 4	3/98	Ibaraki et al				
	5 7 5 5 3 0 3	5/98	Yamamoto et al				
	5 7 7 8 9 9 7	7/98	Setaka et al				
	5 7 8 5 1 3 6	7/98	Falkenmayer et al				
	5 7 8 5 1 3 7	7/98	Reuyi				
	5 7 8 5 1 3 8	7/98	Yoshida				
DD	5 5 6 6 7 7 4	10/96	Yoshida				

**FOREIGN PATENT DOCUMENTS**

DOCUMENT NUMBER	DATE	COUNTRY	CLASS	SUBCLASS	TRANSLATION	
					YES	NO

**OTHER DOCUMENTS** (Including Author, Title, Date, Pertinent Pages, Etc)

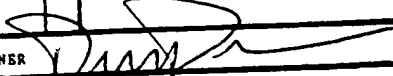
EXAMINER 	DATE CONSIDERED <b>11/19/04</b>	EXAMINER: Initial if citation considered, whether or not citation is in conformance with MPEP §609; Draw line through citation if not in conformance and not considered. Include copy of this form with next communication to the applicant.
---	------------------------------------	--

**INFORMATION DISCLOSURE CITATION  
IN AN APPLICATION**

DOCKET NUMBER **PAICE201** APPLICATION NUMBER **09/822,866**  
 APPLICANT **Severinsky et al**  
 FILING DATE **04/02/01** GROUP ART UNIT **N/A**

**U.S. PATENT DOCUMENTS**

EXAMINER INITIAL	DOCUMENT NUMBER	DATE	NAME	CLASS	SUBCLASS	FILING DATE
DD	5 4 9 2 1 9 0	2/96	Yoshida			
	5 4 4 1 1 2 2	8/95	Yoshida			
	5 5 5 8 1 7 5	9/96	Sherman			
	5 5 5 8 1 7 3	9/96	Sherman			
	5 7 8 8 5 9 7	8/98	Boll et al			
	5 7 8 8 0 0 3	8/98	Spiera			
	5 7 9 1 4 2 6	8/98	Yamada			
	5 3 2 3 8 6 8	6/94	Kawashima			
	5 5 4 5 9 2 8	8/96	Kotani			
	5 2 9 1 9 6 0	3/94	Brandenburg et al			
	5 2 5 5 7 3 3	10/93	King			
	5 6 6 4 6 3 5	9/97	Koga et al			
DD	5 4 6 3 2 9 4	10/95	Valdivia			

**FOREIGN PATENT DOCUMENTS**

DOCUMENT NUMBER	DATE	COUNTRY	CLASS	SUBCLASS	TRANSLATION	
					YES	NO

**OTHER DOCUMENTS** (Including Author, Title, Date, Pertinent Pages, Etc)

EXAMINER *[Signature]* DATE CONSIDERED **11/19/04**  
 EXAMINER: Initial if citation considered, whether or not citation is in conformance with MPEP §609; Draw line through citation if not in conformance and not considered. Include copy of this form with next communication to the applicant.

<b>INFORMATION DISCLOSURE CITATION IN AN APPLICATION</b>	DOCKET NUMBER	PAICE201	APPLICATION NUMBER	09/822,866
	APPLICANT			
	Severinsky et al			
FILING DATE			GROUP ART UNIT	
04/02/01			N/A	

**U.S. PATENT DOCUMENTS**

EXAMINER INITIAL	DOCUMENT NUMBER	DATE	NAME	CLASS	SUBCLASS	FILING DATE
DD	5 5 6 2 5 6 5	10/96	Moroto et al			
	5 5 1 3 7 1 9	5/96	Moroto et al			
	5 5 1 3 7 1 8	5/96	Suzuki et al			
	5 8 3 3 0 2 2	11/98	Welke			
	5 8 4 1 2 0 1	11/98	Tabata et al			
	5 8 8 7 6 7 0	3/99	Tabata et al			
	5 8 6 2 4 9 7	1/99	Yano et al			
	5 6 3 7 9 8 7	6/95	Fattic et al			
	5 6 4 3 1 1 9	7/97	Yamaguchi et al			
	5 6 4 4 2 0 0	7/97	Yang			
	5 4 8 9 0 0 1	2/96	Yang			
	5 6 5 3 3 0 2	8/94	Edye et al			
DD	5 3 5 0 0 3 1	9/94	Sugiyama et al			

**FOREIGN PATENT DOCUMENTS**

DOCUMENT NUMBER	DATE	COUNTRY	CLASS	SUBCLASS	TRANSLATION	
					YES	NO

**OTHER DOCUMENTS** (Including Author, Title, Date, Pertinent Pages, Etc)

EXAMINER	DATE CONSIDERED 11/19/04
EXAMINER: Initial if citation considered, whether or not citation is in conformance with MPEP §609; Draw line through citation if not in conformance and not considered. Include copy of this form with next communication to the applicant.	

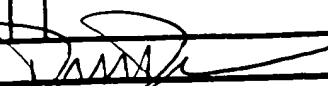
<b>INFORMATION DISCLOSURE CITATION IN AN APPLICATION</b>		DOCKET NUMBER	PAICE201	APPLICATION NUMBER	09/822,856		
		APPLICANT	Severinsky et al				
		FILING DATE	04/02/01	GROUP ART UNIT	N/A		
<b>U.S. PATENT DOCUMENTS</b>							
EXAMINER INITIAL	DOCUMENT NUMBER	DATE	NAME	CLASS	SUBCLASS	FILING DATE	
						YES	NO
D	5 3 4 5 7 6 1	9/94	King et al				
	5 3 3 7 8 4 8	8/94	Bader				
	5 3 2 7 9 9 2	7/94	Holl				
	5 5 8 9 7 4 3	12/96	King				
	5 3 4 5 1 5 4	9/94	King				
	4 8 6 2 0 0 9	8/89	King				
	5 3 7 2 2 1 3	12/94	Hasebe et al				
	5 4 9 5 9 1 2	3/96	Gray, Jr., et al				
	5 5 8 8 4 9 8	12/96	Kitada				
	5 4 9 2 1 8 9	2/96	Kriegler				
	5 1 9 3 6 3 4	3/93	Masut				
	5 1 2 5 4 6 9	6/92	Scott				
	D	4 5 1 1 0 1 2	4/85	Rauneker			
<b>FOREIGN PATENT DOCUMENTS</b>							
DOCUMENT NUMBER	DATE	COUNTRY	CLASS	SUBCLASS	TRANSLATION		
					YES	NO	
<b>OTHER DOCUMENTS</b> (Including Author, Title, Date, Pertinent Pages, Etc)							
EXAMINER				DATE CONSIDERED	11/17/04		
EXAMINER: Initial if citation considered, whether or not citation is in conformance with MPSP §509; Draw line through citation if not in conformance and not considered. Include copy of this form with next communication to the applicant.							





**INFORMATION DISCLOSURE CITATION  
IN AN APPLICATION**

DOCKET NUMBER **PAICE201** APPLICATION NUMBER **09/822,866**  
 APPLICANT **Severinsky et al**  
 FILING DATE **04/02/01** GROUP ART UNIT **N/A**

**U.S. PATENT DOCUMENTS**

EXAMINER INITIAL	DOCUMENT NUMBER	DATE	NAME	CLASS	SUBCLASS	FILING DATE
DD	6 0 5 9 0 5 9	5/00 9/98	Schmidt-Brucken			
	6 0 9 8 7 3 3	8/00	Ibaraki et al			
	6 1 6 1 3 8 4	12/00	Reinbold et al			
	5 9 9 6 3 4 7	12/99	Nagae et al			
	6 1 0 9 0 2 5	8/00	Murata et al			
	6 1 3 1 5 3 8	10/00	Kanai			
	4 7 7 4 8 1 1	10/88	Kawamura			
DD	5 3 2 7 9 9 2	7/94	Boll			
	5 2 4 9 8 3 7	10/93	Heldl et al			
	5 4 9 9 9 0 6	3/96	Furutani			
	6 0 1 8 8 9 4	1/00	Egami et al			
DD	6 2 0 9 6 7 2	4/01	Severinsky			

**DUPLICATION**  
//  
//

**FOREIGN PATENT DOCUMENTS**

DOCUMENT NUMBER	DATE	COUNTRY	CLASS	SUBCLASS	TRANSLATION	
					YES	NO

**OTHER DOCUMENTS** (Including Author, Title, Date, Pertinent Pages, Etc)

EXAMINER *[Signature]* DATE CONSIDERED **11/19/04**

EXAMINER: Initial if citation considered, whether or not citation is in conformance with RPSP 5609; Draw line through citation if not in conformance and not considered. Include copy of this form with next communication to the applicant.



IN THE UNITED STATES PATENT AND TRADEMARK OFFICE

In re the Patent Application of	:	
Severinsky et al	:	Examiner: N/A
Serial No.: 09/822,866	:	Group Art Unit: 3619
Filed: April 2, 2001	:	Att. Dkt.: PAICE201
For: Hybrid Vehicles	:	

Hon. Commissioner of Patents and Trademarks  
Washington, DC 20231

**SUPPLEMENTAL INFORMATION DISCLOSURE STATEMENT**

Dear Sir:

Listed on attached PTO-1449 forms are a number of new patents discovered after filing of the above application. Copies of the listed patents are enclosed. The Examiner is respectfully requested to consider these patents with respect to the claims of this application.

The relevance of the newly-listed patents may be summarized as follows:

US patent 6,307,276 to Bader shows a hybrid drive system comprising an engine, a traction motor coupled to the countershaft of a multispeed transmission, and a controller which determines a running average value for the vehicle's "required driving torque". The engine output power is then varied as the average required power changes. The specification and claims give examples of 15 and 50 seconds as the time period over which the average is calculated, and it is made clear that the engine power is varied accordingly slowly. Where the engine power is insufficient to satisfy the instantaneous torque requirement, the battery is used to supply power to a traction motor; conversely, when the engine is producing more power than is needed, the excess is used to charge the batteries.

Insofar as Fig. 2 of Bader suggests that the "required driving torque" can be negative (for example, a negative torque can be considered to be applied to the motor/generator(s) by the kinetic energy of the vehicle, i.e., under deceleration or

descents, for regenerative braking), this parameter might be misunderstood to be generally comparable to the "road load" parameter, which is analyzed by the present system to make its mode switching determinations, as illustrated by Figs. 6, 7, and 9. However, Bader's "drive power  $P_o$  can be calculated from the torque  $M_o$  and the rotational speed  $n_o$ ". Col. 4, lines 21-22. Hence the "drive power" is not in fact suggestive of applicants' road load, since the engine output, i.e., "the torque  $M_o$  at the gear input" (col. 4, line 18), cannot be negative.

In any event, there is no suggestion in Bader of changing operational modes of a hybrid vehicle responsive to the value of the "drive power  $P_o$ ", whether or not this is fairly equivalent to the road load. As made explicit by the relevant claims 1 - 9 of this application, according to an important aspect of the invention the vehicle is operated in different modes according to the road load (among other variables), and so that the engine is operated only under sufficient load to make its operation efficient. For example, when the road load is low, e.g., at low speeds, the engine is run only as necessary to charge the batteries. By comparison, in Bader it appears the engine is to be run constantly, and its speed varied slowly in accordance with the then average value of drive power. Bader thus fails to teach an important aspect of the invention.

Nii patent 6,131,680 is directed to a hybrid vehicle wherein an internal combustion engine and first and second motors are all connected to one of the sun gear, the planet carrier, or the ring gear of a planetary gearbox. Nii adjusts the relative gear ratios according to the torque required, which is apparently derived directly from the position of the accelerator pedal - see col. 22, lines 27 - 30. The Nii hybrid is operated in different modes depending on the state of charge of the battery, and the torque required. See Fig. 9. Under certain circumstances the planetary gearbox may be locked-up to avoid inefficiency. See, e.g., col. 9 line 1 - 7, and Fig. 10. However, the modes shown by Nii are not the same as those used by applicants, although there

are some similarities. For example, as stated at col. 37, lines 1 - 6, and in Fig. 26, Nii sets his engine speed to idle when the vehicle is being operated in "motor driving" (i.e., electric car) mode; this is highly inefficient, since the engine produces no useful power at idle. By comparison, applicants shut the engine off completely except when it is being operated at high efficiency.

Mikami patent 5,839,533 is discussed in the application as filed, but was apparently not listed on the PTO-1449 forms filed previously; this patent is accordingly listed on the PTO-1449 filed herewith. A copy of this patent is also provided herewith.

Stemler patent 6,300,735 relates to control of planetary gearboxes as might be used in hybrid vehicles to control the torque supplied by the internal combustion engine and electric motors. Such a gearbox is not a feature per se of the invention described by the claims of the present application.

Yanase et al patent 6,318,487 shows a scheme for braking a hybrid vehicle when the battery is fully charged, so that regenerative braking would be inappropriate, and whereby friction braking is avoided; specifically, the engine is motored, so that energy is consumed by compressing air in the engine. This is not a feature of the invention defined by the claims of this application.

Deguchi et al patent 6,278,915 shows a control system for a hybrid comprising a continuously-variable transmission, wherein the transmission ratio is set responsive to target values for the driving torque, the generated electrical power, and the engine speed. Such a transmission is not found in the system defined by the claims of this application, and the control scheme described by this patent is irrelevant to the present claims.

Deguchi et al patent 6,190,282 relates to controlling the engine, motor, and clutch of a hybrid so as to avoid shock to the passengers upon clutch engagement. This is not relevant to the claims of the present application. A similar Deguchi et al patent, 5,993,351, was made of record previously.

Obayashi et al patent 6,232,733 appears to be a further development of the invention described in Egami patents 5,789,881 and 6,018,694, previously made of record. All three of these patents relate to operating the electric motors of a hybrid to reduce vibration when the engine is started. This is not a feature of the claims of this application.

Friedmann et al patent 5,788,004 shows a control system for hybrid vehicles wherein the overall system efficiency is continuously optimized by adjustment of the operational parameters of the various system components.

Kashiwase patent 6,146,302 shows a drive system for a hybrid wherein an engine and first motor are connected to the ring gear of a planetary gearbox, a second motor is connected to its planet carrier, a transmission is connected between the planet carrier and the road wheels of the vehicle, and clutches are provided to engage two of the sun gear, planet carrier and ring gear. No such planetary gearbox is required by the system of the invention.

Frank patent 6,116,363 is stated to be a continuation-in-part of patent 5,842,534, already made of record and discussed in this application as filed. Both of these Frank patents disclose a braking system for a hybrid vehicle wherein the first 30% of pedal travel initiates regenerative braking, while the latter 70% of pedal travel initiates mechanical braking. See also Frank patent 6,054,844, already of record, which limits the braking torque to be provided by regenerative braking as a function of vehicle speed.

Maeda et al patent 6,074,321 shows a transaxle for a hybrid vehicle having a specific construction that is not particularly relevant to any of the claims of this application.

Moroto reissue patent Re. 36,678 is a reissue of patent 5,513,719, already of record.

Finally, Severinsky et al patent 6,338,391 has recently issued on application Serial No. 09/392,743, that is, is one of the parent applications.

An early and favorable action on the merits of the application is earnestly solicited.

2/8/02  
Dated

Respectfully submitted,

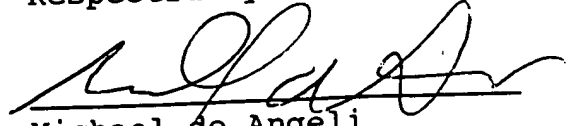

Michael de Angeli  
Reg. No. 27,869  
60 Intrepid Lane  
Jamestown, RI 02835  
401-423-3190







<b>INFORMATION DISCLOSURE CITATION IN AN APPLICATION</b>	DOCKET NUMBER <b>PAICE201</b>	APPLICATION NUMBER <b>09/822,866</b>
	APPLICANT <b>Severinsky et al</b>	
	FILED DATE <b>4/2/2001</b>	GROUP ART UNIT <b>3619</b>
	<b>10/382577</b>	

**U.S. PATENT DOCUMENTS**

EXAMINER INITIAL	DOCUMENT NUMBER	DATE	NAME	CLASS	SUBCLASS	FILING DATE	
DD	Re 366	6-7-85/2000	Moroto et al				
DD	6338	3-9-11/2002	Severinsky et al				

**FOREIGN PATENT DOCUMENTS**

DOCUMENT NUMBER	DATE	COUNTRY	CLASS	SUBCLASS	TRANSLATION	
					YES	NO

**OTHER DOCUMENTS** (Including Author, Title, Date, Pertinent Pages, Etc)

EXAMINER <i>[Signature]</i>	DATE CONSIDERED <b>11/19/07</b>
--------------------------------	------------------------------------

EXAMINER: Initial if citation considered, whether or not citation is in conformance with MPEP §609; Draw line through citation if not in conformance and not considered. Include copy of this form with next communication to the applicant.



THE UNITED STATES PATENT AND TRADEMARK OFFICE

In re the Patent Application of :  
Severinsky et al : Examiner: David Dunn  
Serial No.: 09/822,866 : Group Art Unit: 3616  
Filed: April 2, 2001 : Att. Dkt.: PAICE201  
For: Hybrid Vehicles :  
Hon. Commissioner of Patents and Trademarks  
Washington, DC 20231

**SECOND SUPPLEMENTAL INFORMATION DISCLOSURE STATEMENT**

Dear Sir:

Listed on accompanying PTO-1449 form(s) are a number of additional patents that may be considered relevant by the Examiner to the claims of this application. These patents were identified in supplemental searching conducted after the filing of the application. Copies of the newly-cited documents are provided herewith. The examiner is respectfully requested to consider these documents in connection with the patentability of the claims of this application. Citation of these documents should not be construed to admit they are necessarily statutory prior art effective against this application.

The relevance of the documents thus cited is as follows:

Goehring et al patent 6,394,209 discloses a hybrid vehicle in which the internal combustion engine is stated to be operated only at or near full load. To thus operate the engine of the vehicle of the invention is an object of the invention, and a limitation to that effect is present in claim 1 of the application as amended. However, the Goehring reference refers only to a serial hybrid, and therefore does not teach a hybrid vehicle operated in different modes responsive to the road load, as also required by claim 1.

Tabata et al patent 6,081,042, to be candid, is extremely difficult to comprehend. It does appear that Tabata shows a hybrid vehicle which can be driven by a motor/generator, an

engine, or both, the operation mode to be chosen based on "the currently required output Pd" and the battery state of charge. See Fig. 6 and cols. 17 - 20. Insofar as understood, the value Pd is not the same thing as applicants' instantaneous torque requirement or road load RL. Pd is defined as "an output of the hybrid drive system 210 required to drive the vehicle against a running resistance. This currently required output Pd is calculated according to a predetermined data map or equation, on the basis of the operation amount  $\theta_{AC}$  of the accelerator pedal, a rate of change of this value  $\theta_{AC}$ , running speed of the vehicle (speed  $N_0$  of the output shaft 19) or the currently established operating position of the automatic transmission." Col. 18, lines 34 - 42.

Another Tabata patent, 5,982,045, is directed to control of mode shifting in a hybrid such that transmission ratios or torque distribution ratio changes are prevented from occurring concurrently with mode shifting, the goal evidently being to smooth mode shifting. No disclosure of control of mode shifting responsive to a quantity comparable to applicants' road load is apparent.

Lawrie et al patent 5,993,350 discloses an "automated manual transmission clutch controller" which purports to combine the advantages of conventional automatic and manual transmissions. Mode shifting is evidently carried out responsive to any or several of various "information..includ[ing] vehicle speed, RPM or the like..[or] other vehicle condition signals". Col. 8, lines 37 - 49. The disclosures of three further Lawrie and Lawrie et al patents, 6,006,620, 6,019,698, and 5,797,257 appear to be essentially identical.

Nagano et al patent 6,059,064 shows a hybrid vehicle and appears to be directed to improvements in the braking system employed; these include using a prime mover (e.g., an electric motor) on one axle and another, e.g., an IC engine on another axle. Hill-holding is also addressed, as is anti-lock. The improvements in brake "feel" addressed in the present application do not appear to be discussed by Nagano.

The Examiner is respectfully urged to consider these patents in connection with examination of this application, and to indicate that he has done so in the file of the case.

Respectfully submitted,



Michael de Angeli  
Reg. No. 27,869  
60 Intrepid Lane  
Jamestown, RI 02835  
401-423-3190

9/1/02

Dated



J0498 U.S. PTO  
 10/382577  
 03/07/03

<b>INFORMATION DISCLOSURE CITATION IN AN APPLICATION</b>	DOCKET NUMBER <b>PAICE201</b>	APPLICATION NUMBER <b>09/822,866</b>
	FILING DATE <b>4/2/2001</b>	GROUP AND UNIT <b>3616</b>
<b>U.S. PATENT DOCUMENTS</b>		

EXAMINER INITIAL	DOCUMENT NUMBER	DATE	NAME	CLASS	SUBCLAS	FILING DATE
DD	639420	95/2002	Goehring et al			
	608104	26/2000	Tabata et al			
	598204	511/1999	Tabata et al			
	599335	011/1999	Lawrie et al			
	601969	802/2000	Lawrie et al			
	597925	711/1999	Lawrie			
	600662	012/1999	Lawrie et al			
DD	605906	405/2000	Nagano et al			

FOREIGN PATENT DOCUMENTS						
DOCUMENT NUMBER	DATE	COUNTRY	CLASS	SUBCLASS	TRANSLATION	
					YES	NO

OTHER DOCUMENTS	(Including Author, Title, Date, Pertinent Pages, Etc)

EXAMINER		DATE CONSIDERED	<b>11/14/04</b>
----------	--	-----------------	-----------------

EXAMINER: Initial if citation considered, whether or not citation is in conformance with MPEP §609; Draw line through citation if not in conformance and not considered. Include copy of this form with next communication to the applicant.

**Notice of Reference Cited**

Application/Control No.

09/822,866

Applicant(s)/Patent Under Reexamination  
SEVERINSKY ET AL.

Examiner

David Dunn

Art Unit

3616

Page 1 of 6

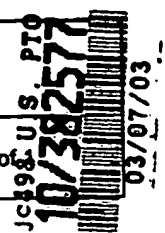
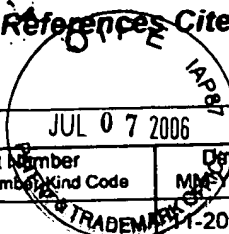

**U.S. PATENT DOCUMENTS**

*	Document Number Country Code-Number-Kind Code	Date MM-YYYY	Name	Classification
A	US-6,315,068	11-2001	Hoshiya et al.	180/65.2
B	US-6,330,498	12-2001	Tamagawa et al.	701/22
C	US-6,359,404	03-2002	Sugiyama et al.	318/432
D	US-6470983	10-2002	Amano et al.	180/65.2
E	US-			
F	US-			
G	US-			
H	US-			
I	US-			
J	US-			
K	US-			
L	US-			
M	US-			

**FOREIGN PATENT DOCUMENTS**

*	Document Number Country Code-Number-Kind Code	Date MM-YYYY	Country	Name	Classification
N					
O					
P					
Q					
R					
S					
T					

**NON-PATENT DOCUMENTS**

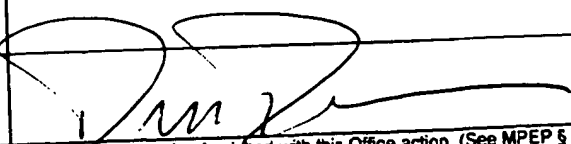
*	Include as applicable: Author, Title, Date, Publisher, Edition or Volume, Pertinent Pages)
U	
V	
W	
X	 11/19/04

\*A copy of this reference is not being furnished with this Office action. (See MPEP § 707.05(a).)  
Dates in MM-YYYY format are publication dates. Classifications may be US or foreign.



IN THE UNITED STATES PATENT AND TRADEMARK OFFICE

In re the Patent Application of :  
 Severinsky et al : Examiner: David Dunn  
 Serial No.: 09/822,866 : Group Art Unit: 3616  
 Filed: April 2, 2001 : Att. Dkt.: PAICE201  
 For: Hybrid Vehicles :

Hon. Commissioner of Patents and Trademarks  
 Washington, DC 20231

THIRD SUPPLEMENTAL INFORMATION DISCLOSURE STATEMENT

Dear Sir:

Listed on accompanying PTO-1449 form(s) are five Japanese patent publications that may be considered relevant by the Examiner to the claims of this application. These publications were cited by the Japanese Patent Office in an office action dated September 2, 2002 in connection with prosecution of a Japanese patent application corresponding to the parent US applications, Ser. No. 09/264,817, now patent 6,209,672, and Ser. No. 09/392,743, now patent 6,338,391. A copy of a translation of this Japanese office action is attached, and copies of the newly-cited documents are provided herewith marked (1) - (5), in accordance with the Japanese Examiner's usage; copies of uncertified, partial translations of references 1 and 4 are also provided. The Examiner is respectfully requested to consider these documents in connection with the patentability of the claims of this application.

The relevance of the documents thus cited is as follows:

Japanese utility model registration 63-82283, published as "laid-open No. 2-7702", which was referred to in the Japanese office action as Reference 1 (a partial noncertified translation also being supplied), shows a hybrid vehicle comprising an internal combustion engine, an electric "traction" motor for providing additional torque to the wheels of the vehicle, and a

second electric motor that can be operated to also supply additional torque to the wheels or operate as a generator to charge the battery during braking or hill descent. Typically, such hybrids are operated in different modes depending on whether the vehicle is sitting at a traffic light, accelerating, cruising on the highway, and so on. The same is true of the vehicle of the present invention.

In order that the hybrid vehicle can be made commercially acceptable, it is important that the "mode switching" decisions be made by a microprocessor or the like instead of the driver. Various references teach making this decision in different ways. Reference 1 does not address this question. Commonly, as in Japanese published application 06-080048, cited by the Japanese patent office as Reference 3 (which corresponds to US patent 5,697,466, already of record), the decision is made based on the degree to which the driver has depressed the accelerator pedal. By comparison, according to the present invention, as discussed extensively in the earlier prosecution of this and the parent applications, the mode switching decision is made based on the vehicle's instantaneous torque requirement or "road load" RL.

As previously, it is important to emphasize exactly what the terms "road load" RL means as used in the present claims, to distinguish over the art. "Road load" is a somewhat subtle concept, since during many phases of vehicle operation the road load quantitatively resembles, for example, the operator's foot pressure on the accelerator pedal, or simply the engine output power. However, the road load as used herein is neither of these. "Road load" as used herein is simply that amount of torque that must be supplied to the vehicle wheels in order to carry out the operator's current command.

Note that "road load" as thus defined can be positive, as during highway cruising, "highly" positive, as during acceleration or hill-climbing, negative, as during hill descent, and "heavily" negative, as during braking. Figs. 7 and 13 show



this clearly, and it is explained in the specification of the application as well. The flowchart of Fig. 9 illustrates precisely how the mode switching decisions are made responsive to road load (with an additional variation possible based on the battery state of charge.)

The fact that according to the present invention the mode switching decisions are made responsive to road load, a quantity which can be positive or negative, distinguishes this invention from all prior art of which we are aware. It will be appreciated that making all of the mode switching decisions based essentially on monitoring this single variable (with subsidiary attention to the battery state of charge, as below) greatly simplifies the decision-making process, as compared, for example, to a system in which the operator's foot pressure on the throttle and brake pedals must be continually monitored.

The new references made of record hereby does not show this invention. Reference 1 does show a hybrid vehicle having components arranged comparably to those recited in claim 1, but there is no mention of the manner in which the mode-switching determinations are made. The Japanese Examiner made the comment that "the vehicle is operated in a plurality of operating modes in response to states of operation such as a load of the vehicle and the like", apparently based on the description in reference 1 of vehicle operation in different modes depending on the driving conditions. However, we find nothing in reference 1 that suggests mode switching based on road load as defined above.

None of the other references cited by the Japanese Examiner and made of record hereby (nor any of those previously made of record, of course) supply this deficiency of Reference 1. The Japanese Examiner cited published application 06-144020 (referred to as reference 2) against claim 1, for showing that the first motor also starts the engine, and cited reference 3 against claim 2, for showing that the state of charge of the battery can be considered in mode switching.

More specifically, in his remarks concerning claim 4, the Japanese Examiner asserted that reference 3 describes mode switching responsive to "road load (a press down amount of an accelerator pedal) (see [Fig. 3]) or the like". As above, "road load" as used in this application is something quite different than the degree to which the accelerator pedal is pressed down; for example, the latter cannot be negative, and road load as used herein can decidedly be negative. We have reviewed US patent 5,697,466 (which corresponds to Reference 3) in detail and it shows nothing comparable to mode switching based on road load as used in this application.

Claims 8 and 9 of this application are directed to the "turbocharger-on-demand" concept, which was an important aspect of the invention in parent application Ser. No. 09/392,743, now patent 6,338,391. Claims 15 - 20 of the Japanese application recite this concept, i.e., that of a turbocharger that is operated only when the road load exceeds a predetermined value for more than a minimum period of time. That is, the turbocharger is not operated continually, as in the usual prior art vehicles, but is only operated when needed, i.e., when road load exceeds the engine's normally aspirated torque capabilities (i.e.,  $RL > MTO$ ); moreover, the turbocharger is operated only when  $RL > MTO$  for more than some predetermined period of time  $T$ . This is an extremely powerful concept, and one which is only applicable to a hybrid vehicle. Providing the turbocharger on demand allows the engine to provide additional torque when needed, but to operate as a smaller, more efficient engine at other times.

More specifically, in a conventional turbocharged vehicle the turbocharger is spinning constantly, so that a turbine driven by the exhaust flow drives a compressor forcing air into the engine. The main problem with turbochargers as thus used is poor throttle response or "turbo lag", that is, a substantial time delay between the driver calling for more power by pressing on

the accelerator pedal and the engine's response. While some progress has been made, mostly by use of smaller turbochargers, this problem is inevitable to some degree, since it takes some time for the turbocharger to "spool up" to its full speed.

The Japanese Examiner cited Japanese published application 55-069724 as reference 4; as noted, a partial noncertified translation of this reference is also provided. Reference 4 shows a turbocharger which is operated on demand, in response to a "load detecting means"; this is the first reference we have seen showing this concept. There is no suggestion of use of this turbocharger in a hybrid vehicle. A conventional (i.e., non-hybrid) vehicle fitted with a turbocharger of this type would have extremely poor throttle response if used to provide additional power for passing (i.e., overtaking) or hillclimbing; the "turbo lag" inherent in operation of a turbocharger starting from zero rpm would be on the order of tens of seconds, which would be totally unacceptable for a consumer vehicle. Possibly such a system would be useful in heavy truck operation or the like, where the load will vary significantly depending on whether the truck was loaded or not; in that case, the operator could be the "load detecting means", i.e., could throw a switch when he knew high power would be needed for an extended period of time.

By comparison, a turbocharger can be employed "on demand" in a hybrid vehicle according to the invention without poor throttle response caused by turbo lag, and without requiring any intervention by the operator. This is simply because the traction motor can be used to supply the vehicle's torque requirements in excess of MTO. Thus, when  $RL > MTO$ , the traction motor provides the additional torque required. If  $RL > MTO$  for longer than T, the turbocharger is activated and begins to spin. When it is up to operating speed, the traction motor can be deactivated. All this is shown clearly by Fig. 13, and would not be possible simply given the turbocharger-on-demand of Reference 4 in a conventional, non-hybrid vehicle. By comparison, in the

present vehicle, at no point are the vehicle's torque requirements not met; therefore there is no "turbo lag".

It is apparent that this advantage can only be achieved by use of a turbocharger on demand in a hybrid vehicle. No combination of references can fairly be said to make this obvious. Specifically, the Japanese Examiner's comment as to claim 17, "it is a usual matter to control a turbocharger in response to a road load or the like" is not correct, for several reasons: no reference shows taking any kind of control action in response to road load as claimed; no reference suggests combining the turbocharger on demand of Reference 4 with a hybrid vehicle; and certainly no reference suggests the complete elimination of the turbo lag problem thus achieved, while at the same time the vehicle's useful load range is greatly broadened.

Finally, Japanese published application 04-274926 (Reference 5) was cited for a showing of preheating a catalyst before starting the associated engine, which is not a feature of the present claims.

The Examiner is respectfully urged to consider these patents in connection with examination of this application, and to indicate that he has done so in the file of the case.

Nov. 28, 2002  
Dated

Respectfully submitted,



Michael de Angeli  
Reg. No. 27,869  
60 Intrepid Lane  
Jamestown, RI 02835  
401-423-3190



**This Page is Inserted by IFW Indexing and Scanning  
Operations and is not part of the Official Record**

**BEST AVAILABLE IMAGES**

Defective images within this document are accurate representations of the original documents submitted by the applicant.

Defects in the images include but are not limited to the items checked:

- BLACK BORDERS
- IMAGE CUT OFF AT TOP, BOTTOM OR SIDES
- FADED TEXT OR DRAWING
- BLURRED OR ILLEGIBLE TEXT OR DRAWING
- SKEWED/SLANTED IMAGES
- COLOR OR BLACK AND WHITE PHOTOGRAPHS
- GRAY SCALE DOCUMENTS
- LINES OR MARKS ON ORIGINAL DOCUMENT
- REFERENCE(S) OR EXHIBIT(S) SUBMITTED ARE POOR QUALITY
- OTHER: \_\_\_\_\_

**IMAGES ARE BEST AVAILABLE COPY.**

**As rescanning these documents will not correct the image problems checked, please do not report these problems to the IFW Image Problem Mailbox.**

LFu



IN THE UNITED STATES PATENT AND TRADEMARK OFFICE

In re the Patent Application of :

Severinsky et al	:	Examiner: N/A
	:	
Serial No.: 11/429,457	:	Group Art Unit: 3616
	:	
Filed: May 8, 2006	:	Att.Dkt:PAICE201.DIV.3
	:	
For: Hybrid Vehicles	:	

Hon. Commissioner for Patents  
P.O. Box 1450  
Alexandria VA 22313-1450

INFORMATION DISCLOSURE STATEMENT

Sir:

Listed on an attached PTO-1449 are several Japanese references that have recently come to applicants' attention in connection with related foreign applications, and US patent 6,383,114, cited against copending Ser. No. 11/426,466. Citation of these documents herein is not to be construed as a concession that they are in fact available as prior art under 35 USC Sect. 102. Copies of the documents thus cited are attached. The Examiner is respectfully requested to consider the documents thus made of record, and to initial the PTO-1449 form, indicating that he or she has done so.

Should there be any questions the Examiner is invited to contact the undersigned at the number given below.

Early and favorable consideration of the application  
is earnestly solicited.

8/20/07

Dated:

Respectfully submitted,

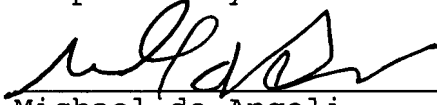

Michael de Angeli  
Reg. No. 27,869  
60 Intrepid Lane  
Jamestown RI 02835  
401-423-3190





INFORMATION DISCLOSURE CITATION  
IN AN APPLICATION

DOCKET NUMBER PAICE201.DIV APPLICATION NUMBER 11/429,457  
 APPLICANT Severinsky et al  
 FILING DATE May 8, 2006 GROUP ART UNIT 3618

U.S. PATENT DOCUMENTS

EXAMINER INITIAL	DOCUMENT NUMBER	DATE	NAME	CLASS	SUBCLAS	FILING DATE	
	6 3 8 3 1 1 4	5/2002	Hoshiya et al				

FOREIGN PATENT DOCUMENTS

DOCUMENT NUMBER	DATE	COUNTRY	CLASS	SUBCLASS	TRANSLATION	
					YES	NO
02 1 0 1 9 0 3	1990	Japan				part.
55 1 2 7 2 2 1	1980	Japan				x
06 1 4 4 0 2 0	1994	Japan				x
04 3 4 1 6 5 7	1992	Japan				sketch

OTHER DOCUMENTS (Including Author, Title, Date, Pertinent Pages, Etc)

EXAMINER: Initial if citation considered, whether or not citation is in conformance with MPEP §609; Draw line through citation if not in conformance and not considered. Include copy of this form with next communication to the applicant.

EXAMINER: \_\_\_\_\_ DATE CONSIDERED \_\_\_\_\_

# PATENT ABSTRACTS OF JAPAN

(11)Publication number : 02-101903  
(43)Date of publication of application : 13.04.1990

(51)Int.Cl. B60L 11/12

(21)Application number : 63-253385 (71)Applicant : AISIN AW CO LTD  
EKUOSU RES:KK  
(22)Date of filing : 07.10.1988 (72)Inventor : TOYODA MINORU  
MOROTO SHUZO  
KAWAMOTO MUTSUMI

## (54) BATTERY CHARGER FOR MOTOR CAR

### (57)Abstract:

**PURPOSE:** To reduce the size and the weight of a battery by mounting at least one of a plurality of motors onto a motor vehicle and driving the motor through at least one generating engine then connecting the motor with the battery for a motor car.

**CONSTITUTION:** Front wheels 2, 3 of a car 1 are driven through one motor M16 while the rear wheels 4, 5 thereof are driven through another motor M27, where the two motors 6, 7 are connected with a battery 9. The wheels W can be made free by disengaging a clutch C. Since the battery is charged during low speed running, idle running or stoppage, discharge amount of the battery is low even after long time running of a motor vehicle and thereby the discharge depth decreases, the service life of the battery is lengthened and the size and the weight of the battery charger are reduced.

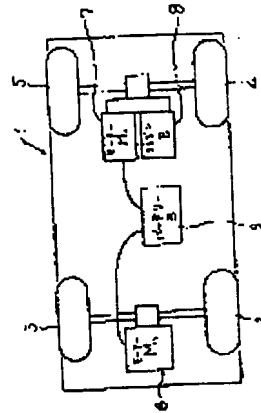

## LEGAL STATUS

[Date of request for examination]

[Date of sending the examiner's decision of rejection]

[Kind of final disposal of application other than the examiner's decision of rejection or application converted registration]

[Date of final disposal for application]

[Patent number]

[Date of registration]

[Number of appeal against examiner's decision of rejection]

⑩ 日本国特許庁 (J P)

⑪ 特許出願公開

⑫ 公開特許公報 (A)

平2-101903

⑬ Int. Cl.<sup>5</sup>  
B 60 L 11/12

識別記号

庁内整理番号  
7304-5H

⑭ 公開 平成2年(1990)4月13日

審査請求 未請求 請求項の数 3 (全14頁)

⑮ 発明の名称 電動車両における蓄電池の充電装置

⑯ 特 願 昭63-253385

⑰ 出 願 昭63(1988)10月7日

⑱ 発 明 者 豊 田 稔 愛知県安城市藤井町高根10番地 アイシン・エイ・ダブリ  
ユ株式会社内

⑲ 発 明 者 諸 戸 脩 三 愛知県安城市藤井町高根10番地 アイシン・エイ・ダブリ  
ユ株式会社内

⑳ 発 明 者 川 本 睦 愛知県安城市藤井町高根10番地 アイシン・エイ・ダブリ  
ユ株式会社内

㉑ 出 願 人 アイシン・エイ・ダブ 愛知県安城市藤井町高根10番地  
リュ株式会社

㉒ 出 願 人 株式会社エクオス・リ 東京都千代田区外神田2丁目19番12号  
サーチ

㉓ 代 理 人 弁理士 青木 健二 外5名

明 細 書

1. 発明の名称

電動車両における蓄電池の充電装置

2. 特許請求の範囲

(1) 複数の電動モータによって複数の車輪が回転駆動されるようになっている電動車両において、

少なくとも1個の発電用エンジンが設けられ、この発電用エンジンに前記複数の電動モータのうち少なくとも一つが接続されているとともに、この電動モータが蓄電池に電気的に接続されていることを特徴とする電動車両における蓄電池の充電装置。

(2) 前記複数の電動モータのうち少なくとも一つがクラッチを介して前記車輪に連結されていることを特徴とする請求項1記載の電動車両における蓄電池の充電装置。

(3) 前記発電用エンジンがクラッチを介して前記電動モータに連結されていることを特徴とする請求項1または2記載の電動車両における蓄電池の充電装置。

3. 発明の詳細な説明

(産業上の利用分野)

本発明は、複数の電動モータによって推進される電動車両に関し、特に、この電動車両に搭載されて電動モータのエネルギー供給源である蓄電池の充電装置に関するものである。

(従来の技術)

内燃機関による自動車においては、従来から、排気ガスによる大気汚染や車両走行時の騒音等の公害が重大問題となっている。このようなことから、電気自動車が研究開発されてきている。この電気自動車は車輪を電動モータによって回転することにより走行するようになっている。このような電気自動車には内燃機関が車両の推進用として搭載されていないので、電気自動車は排気ガスを出すこともなければ、大きな騒音が生じるようなこともない。

(本発明が解決しようとする課題)

ところで、このような電気自動車を走行させるためには、電動モータを駆動させなければなら

いが、このモータを駆動させるエネルギー源として、蓄電池が必要となる。この蓄電池として、多くの種類の蓄電池が研究開発されてきているが、種々の問題があってその実用化がなかなか難しい。このような中で実用化がされている電池の一つに、鉛電池がある。

一般に蓄電池は、瞬間的に出力し得るパワーの大きさを問わずパワー密度や蓄積可能なエネルギー量を問わずエネルギー密度が一般の内燃機関に比べると非常に低い。したがって、現在のガソリン自動車とはほぼ同じ走行性能を確保しようとする、蓄電池の容量をかなり大きくしなければならぬ。そこで、蓄電池の容量をかなり大きくしようとすると、重量が非常に大きくなり、例えば鉛電池の場合にはガソリン自動車に搭載されるエンジン、トランスミッションの駆動系重量の約5倍強の重量となってしまふ。このため、このような鉛電池を車体に搭載した場合、車両性能がきわめて悪くなってしまふ。しかも、鉛電池が大型となるので、車両内のスペースが大きくとられてしまふように

また、本発明の他の目的は、蓄電池のパワー密度を高くしてもエネルギー密度の減少を補うことのできる電動車両における充電装置を提供することである。

(課題を解決するための手段)

前述の課題を解決するために、請求項1の発明は、複数の電動モータによって複数の車輪を回転駆動するようにするとともに、これらの複数の電動モータのうち少なくとも一つを電動車両に搭載した少なくとも1個の発電用エンジンによって回転駆動するようにしている。

そして、この発電用エンジンによって回転駆動される電動モータを電動車両の蓄電池に電気的に接続するようにしている。

また、請求項2の発明は、電動モータと車輪とをクラッチにより連結するようにしている。

更に、請求項3の発明は電動モータと発電用エンジンとをクラッチにより連結するようにしている。

(作用)

なる。

また、鉛電池はエネルギー密度を上げるとパワー密度が下がり、パワー密度を上げるとエネルギー密度が下がるという相反する特性を有している。したがって、鉛電池は、パワー密度もエネルギー密度も高くすることが求められる電気自動車にはそのまま適用することはできない。

更に一般に、蓄電池は一回の放電量を表わす放電深度が大きいほどその寿命が短くなるという性質を有している。すなわち、放電深度が大きいと、充、放電できる回数が減少してしまう。したがって、蓄電池の寿命を短くすることなく、電気自動車を長時間走行可能にすることは難しいものとなっている。

本発明は、このような問題に鑑みてなされたものであって、その目的は、放電深度を大きくしないようにして蓄電池の寿命を延ばすことができるようにしながら、しかも蓄電池をできるだけ小型にしてその重量を低減することのできる電動車両における蓄電池の充電装置を提供することである。

このような構成をした本発明による電動車両における充電装置においては、電動車両が走行する際、各車輪は電動モータの回転駆動力によって回転するようになる。その場合、車両加速時、高速走行時あるいは加速時においては比較的大きな電動モータの駆動力が必要となるので、搭載されているすべての電動モータによって、それらの電動モータにそれぞれ対応する車輪が回転駆動される。

一方、低速走行時、惰性走行時あるいは車両停止時においてはそれほど大きな電動モータの駆動力を必要としないので、複数の電動モータのうち一部の電動モータを車輪の回転駆動用に用いれば済むようになる。したがって、残りの電動モータは車輪の回転駆動に寄与する必要がなくなる。

そこで、この残りの電動モータを車両に搭載された発電用エンジンによって回転させることにより、残りの電動モータは起電力を生じるようになる。すなわち、低速走行時、惰性走行時あるいは車両停止時には、残りの電動モータが発電機として機能するようになる。そし

て、残りの電動モータによって生じた電気は電動車両の蓄電池に蓄えられる。すなわち、蓄電池は充電されることになる。

また、クラッチにより電動モータと車輪との連結を切り離せば、電動モータは発電機として機能するときに車輪の回転に影響されることはない。したがって、エンジンの燃焼効率のよい領域で常時発電が行われるようになる。

このように本発明によれば、低速走行時、慣性走行時あるいは車両停止時には、蓄電池は必ず充電されるようになるので、電動車両が長時間走行してもその放電量は比較的小さい。すなわち、蓄電池の放電深度は小さくなる。

また、電動車両が走行するときには蓄電池が必ず充電されることになるので、蓄電池の容量をそれほど大きくしなくても済むようになる。したがって、蓄電池のエネルギー密度が小さくてもよいことになるので、蓄電池はパワー密度の大きな蓄電池を使用することができるようになる。

更に、電動車両のブレーキとして回生ブレーキ

車両1は左右一対の前輪2, 3と後輪4, 5とを備えている。前輪2, 3は一つの電動モータM1 6によって回転駆動されるようになっており、また、後輪4, 5は一つの電動モータM2 7によって回転駆動されるようになっており、エンジンE 8によっても回転駆動されるようになっている。このエンジン8は電動モータ7をも回転駆動するようになっている。そして、二つの電動モータ6, 7は蓄電池9にそれぞれ接続されている。

また、第1図(B)に示されている配置例では、前輪2, 3がそれぞれ別の電動モータM1 6, 6によって回転されるようになっている点でのみ(A)の場合と異なる。

この場合にも、前輪2, 3を回転する二つの電動モータ6, 6は蓄電池9に接続されている。

更に、第1図(C)に示されている配置例では、後輪4, 5がそれぞれ別の電動モータM2 7, 7によって回転されるようになっており、それぞれ別のエンジンE 8, 8によっても回転され

を採用し、電動モータをその発電機として用いれば、蓄電池は車両のブレーキ作動時に発生した電気によっても充電することができるようになる。したがって、より一層放電深度を小さくすることができるようになる。その場合、クラッチにより電動モータとエンジンとを切り離せば、回生ブレーキ時にエンジンブレーキが作用しなくなるので、このエンジンブレーキによるロスがなくなり、回生ブレーキにおける発電量を大きくすることができる。

(実施例)

以下、図面を用いて本発明の実施例を説明する。

第1図は本発明に係る電動車両における前後左右の車輪、電動モータ、発電用エンジンおよび蓄電池の配置を示し、(A)~(C)はこの配置のそれぞれ異なる例を説明する説明図である。なお、(A)~(C)において、同じ構成要素には同じ符号を付すことにより重複説明を避けることにする。

第1図(A)に示されている配置例では、電動

ようになっている点で、(B)と異なる。この場合にも、両エンジン8, 8はそれぞれ対応する電動モータ7, 7を回転するようになっている。そして、両電動モータ7, 7も蓄電池9に接続されている。

第2図は駆動力伝達系のレイアウトを示し、(A)は発電用エンジンが付いていない場合のスキマティック図であり、(B)は発電用エンジンが付いている場合のスキマティック図である。

第2図(A)の①に示されているものは、電動モータM1が車輪Wに直結されている。この場合には、電動モータM1と車輪Wとが常時連結されているので、車輪Wをフリーにすることはできない。

また同図(A)の②に示されているものは、電動モータM1がクラッチCを介して車輪Wに連結されている。この場合には、クラッチCを切ることにより、車輪Wをフリーにすることができる。したがって、例えば走行中動力がなくなったとき、クラッチCを切れば車輪Wと電動モータM1とが

互いに独立するので、モータM1の慣性が車輪Wに作用しなくなる。また車両が停止状態にあっても、電動モータM1は作動状態に保持することが可能となる。

この場合の電動モータM1は、車両減速時に回生ブレーキの発電機として用いられるとき以外は、車両推進のための車輪Wの回転駆動にのみ用いられる。

第2図(B)に示されているように、電動モータM2と発電用エンジンEとは車輪Wに対して直列結合されている場合と並列結合されている場合とが示されている。直列結合と並列結合とは結合の形態が異なるだけであり、駆動力伝達の点では実質的に同じである。

同図(B)の①に示されているものは、車輪Wに電動モータM2と発電用エンジンEが直結されているとともに、モータM2と発電用エンジンEとが互いに直結されている。

このレイアウトにおいては、比較的大きな駆動力が必要である車両発進時に、電動モータM2は

ことができないので、発電は不可能となる。更に、惰性走行時にはモータM2およびエンジンEも単に惰性回転を行うだけであるので、やはり発電はほとんど不可能である。

一方、電動モータM2は、車両減速時に回生ブレーキの発電機として用いられる。この場合には、エンジンEがモータM2と直結しているので、エンジンブレーキによるロス分だけ回生量が減少する。

更にエンジン始動においては、車輪Wが停止しているので、車両停止状態からのエンジンEを始動させることは不可能である。

このレイアウトにおいてはクラッチがないので、部品点数が少なくなるばかりでなく、構造が簡単になるという利点がある。

同図(B)の②に示されているものは、モータM2とエンジンEとがクラッチC1を介して連結されている。また(B)①の場合と同様に、モータM2とエンジンEとが互いに直結されている。

車両発進時、加速時あるいは高速走行時には、

車輪Wの回転駆動のために用いられる。その場合、大駆動力が必要なときには、発電用エンジンEの駆動力を付加することができるようになっている。同様に加速時および高速走行時にも、モータM2は車輪Wの回転駆動のために用いられる。

それほど大きな駆動力が必要でない低速走行時には、電動モータM2は車輪Wの回転駆動のために用いなくても済むようになる。そこで、エンジンEによってこのモータM2を回転させることにより、モータM2に発電を行わせるようにする。すなわち、低速走行時にはモータM2は発電機として使用される。こうして、エンジンEによる発電を行うことができるようになる。ただしこの場合には、エンジンEおよびモータM2がともに車輪Wに直結されているので、エンジンEの回転数が車速すなわち車輪Wの回転数によって決定されてしまう。このため、燃焼効率のよい領域でエンジンEを常時使用することは不可能である。

また、車両停止時には車輪Wが停止することからモータM2およびエンジンEがともに作動する

クラッチC1を接続することにより、モータM2は車輪Wの回転駆動のために用いられる。すなわち、クラッチC1を接続するとモータM2およびエンジンEが車輪Wに直結されることになるので、前述の(B)①の場合と全く同じになる。

低速走行時、車両停止時あるいは惰性走行時にはそれほど駆動力が必要ではないので、クラッチC1を切ることによりモータM2は車輪Wから切り離される。このため、モータM2は車輪Wの回転駆動用としては用いられない。そして、モータM2はエンジンEによって回転駆動されることにより起電力を発生する。すなわち、モータM2は発電機として用いられるようになる。その場合、モータM2およびエンジンEは車輪Wから切り離されているので、車輪Wの回転の影響がエンジンEの回転に及ばない。これにより、エンジンEの燃焼効率のよい領域を常時使用可能となる。したがって、効率よく蓄電池を充電させることができるようになる。

車両減速時には、クラッチC1を接続すること

により、モータM2を回生ブレーキの発電機として機能させることができる。この場合には、前述の(B)①の場合と同様にエンジンEとモータM2とが直結されるようになるので、エンジンブレーキによるロス分だけ回生量が減少する。

更にエンジン始動時には、クラッチC1を切ってモータM2およびエンジンEと車輪Wとを切り離すことにより、エンジンEをモータM2によって始動することができるようになる。したがって、この場合にはエンジンを駆動するためのスタータモータが不要となる。

同図(B)の④に示されているものは、モータM2が車輪Wに直結されているが、エンジンEはクラッチC1を介して車輪WおよびモータM2に接続されている。

このレイアウトでは、クラッチC1を接続すると、前述の(B)①の場合と全く同じになる。したがって、クラッチC1が接続される車両発進時、加速時、高速走行時および低速走行時については、その説明は省略する。

始動させることは不可能となる。

同図(B)の④に示されているものは、モータM2がクラッチC1を介して連結されているとともに、エンジンEが二つのクラッチC1、C2を介して連結されている。またモータM2とエンジンEとはクラッチC2を介して連結されている。したがって、このレイアウトではクラッチが更に一つ増加している。

車両発進時、加速時あるいは高速走行時には、クラッチC1を接続することにより、モータM2は車輪Wの回転駆動のために用いることができるようになる。また、両クラッチC1、C2をともに接続するとモータM2およびエンジンEが車輪Wに直結されることになるので、前述の(B)①の場合と全く同じになる。したがって、その説明は省略する。

低速走行時には、クラッチC1を切り、クラッチC2を接続することにより、モータM2を発電機として用いることが可能となる。すなわち、エンジンEによってモータM2を駆動すれば、モータ

一方、車両停止時にはモータM2が駆動できなく、また慣性走行時にはモータM2が単に慣性回転するだけであるので、この場合も(B)①の場合と同じになる。

更に、車両減速時には、モータM2が回生ブレーキの発電機として機能する。その場合、クラッチC1を切って車輪WおよびモータM2とエンジンEとを切り離すと、エンジンブレーキが作動しなくなるので、エンジンブレーキによるロスが生じないようになる。したがって、回生量の減少はないので、従来の電気自動車の場合とほぼ同等の発電量を得ることができるようになる。

更に、エンジンEの始動時には、クラッチC1を切るとモータM2とエンジンEとが切り離されるので、モータM2はエンジンEを駆動することができない。したがって、スタータモータを設ける必要がある。またクラッチC1を接続すると、車輪W、モータM2およびエンジンEが互いに直結することになり、(B)①の場合と全く同じになる。すなわち、エンジンEを車両停止状態から

モータM2は起電力を生じ、エンジンEによる発電ができるようになる。しかも、クラッチC1が切られて車輪WとモータM2とエンジンEとが切り離されているので、(B)②の場合と同様、エンジンEの回転は車輪Wの回転に影響されるようなことはない。したがって、発電するために、燃焼効率のよい領域でエンジンEを常時使用することができるようになる。

また車両停止時および慣性走行時にはクラッチC1を切り、クラッチC2を接続することにより、モータM2とエンジンEとを接続するとともに、これらを車輪Wから切り離す。これにより、モータM2をエンジンEによって駆動することにより、発電を行なう。このときにも、(B)②の場合と同様、燃焼効率のよい領域でエンジンEを常時使用することができるようになる。

更に、車両減速時にはクラッチC1を接続し、クラッチC2を切ることにより、(B)③の場合と同様、モータM2を回生ブレーキの発電機として用いることができるようになる。この場合にも、

回生量がエンジンブレーキによるロスによって減少することはないので、モータM2は、従来の電気自動車の場合と同等の発電を行うようになる。

更に、エンジン始動時にはクラッチC1を切り、クラッチC2を接続することにより、モータM2を車輪Wから切り離すとともにモータM2をエンジンEに接続する。したがって、この場合には(B)②の場合と同様になる。これにより、車輪Wに関係なく、エンジンEによってモータM2を駆動することが可能となり、車両停止状態からエンジンEを始動させることができるようになる。この結果、エンジンEを駆動するためのスタータモータは不要となる。

同図(B)の③に示されているものは、モータM2がクラッチC1を介して車輪Wに連結されているとともに、エンジンEがクラッチC2を介して車輪Wに連結されている。

車両発進時、加速時あるいは高速走行時には、クラッチC1を接続することにより、モータM2は車輪Wの回転駆動のために用いることができる

エンジン始動時には、モータM2によってエンジンEを駆動するために両クラッチC1、C2をともに接続すると、(B)①の場合と同じになる。そこで、クラッチC2を切ってエンジンEを車輪Wから切り離すと、(B)④の場合と同じになる。したがって、他にスタータモータが必要となる。

同図(B)の④に示されているものは、エンジンEが車輪Wに直結されているとともに、モータM2がクラッチC1を介して車輪Wに連結されている。

このレイアウトではクラッチC1を接合すると(B)①の場合と同じになる。したがって、車両発進時、加速時、高速走行時、低速走行時、車両減速時およびエンジン始動時には、クラッチC1を接合することになるので、(B)①の場合と全く同じになる。それ故、その説明は省略する。

車両停止時には、エンジンEが車輪Wに直結しているので停止してしまい、エンジンEによる発電は行われない。また慣性走行時には、エンジンEが慣性回転をするだけであるので、クラッチC

1が接続、非接続のいずれの状態であってもモータM2はエンジンEによって発電するに十分な回転にまで回転されない。

同図(B)の①に示されているものは、エンジンEがクラッチC1を介して車輪Wに連結されているとともに、モータM2がクラッチC1、C2を介して車輪Wに連結されている。またモータM2とエンジンEとがクラッチC2を介して連結されている。

このレイアウトでは両クラッチC1、C2をともに接続すると(B)①の場合と同じになる。したがって、車両発進時、加速時、高速走行時および車両減速時には、クラッチC1、C2をともに接続することになるので、(B)①の場合と全く同じになる。それ故、その説明は省略する。

また、この場合はクラッチC1を切り、クラッチC2を接続すると、(B)④の場合と同じになる。したがって、低速走行時、車両停止時、慣性走行時およびエンジン始動時には、クラッチC1を切り、クラッチC2を接続することになるので、



(B) ④の場合と全く同じになる。それ故、その説明は省略する。

同図(B)の④に示されているものは、モータM2がクラッチC1、C3を介して車輪Wに連結されているとともに、エンジンEがクラッチC1、C2を介して車輪Wに連結されている。またモータM2とエンジンEとがクラッチC2を介して連結されている。

このレイアウトではすべてのクラッチC1、C2、C3をともに接続すると(B)①の場合と同じになる。したがって、車両発進時、加速時および高速走行時には、クラッチC1、C2、C3をともに接続することになるので、(B)①の場合と全く同じになる。それ故、その説明は省略する。

また、この場合はクラッチC1を切り、クラッチC2、C3を接続すると、(B)④の場合と同じになる。したがって、低速走行時、車両停止時、惰性走行時およびエンジン始動時には、クラッチC1を切り、クラッチC2、C3を接続することになるので、(B)④の場合と全く同じになる。

り、モータM2は起電力を発生するようになる。すなわち、モータM2は発電機として機能する。したがって、このモータM2を蓄電池に接続すれば、エンジンEによる発電で蓄電池を充電させることができる。特に、燃焼効率のよい領域でエンジンEを常時使用することができる同図(B)②、④、⑤、⑥および⑦のレイアウトが効果的に蓄電池を充電させることができる。しかしながら、これらの駆動力伝達のレイアウトには、クラッチが1~3個配設されているので、部品点数が多くなるばかりでなく、場合によってはその構造も複雑となる。したがって、どのレイアウトを選択するかは、その使用目的に応じて適宜選択する必要がある。

一方、車両減速時にもモータM2は回生ブレーキの発電機として機能するようになる。その場合、同図(B)②、④、⑤、⑥および⑦の場合が特に効果的に発電するようになる。したがって、回生ブレーキの発電量をも考慮してレイアウトを選択することが望ましい。

それ故、その説明は省略する。

更に、この場合はクラッチC1、C3を接続し、クラッチC2を切ると、(B)④の場合と同じになる。したがって、車両減速時には、クラッチC1、C3を接続し、クラッチC2を切ることになるので、(B)④の場合と全く同じになる。それ故、その説明は省略する。

同図(B)の④に示されているものは、モータM2がクラッチC1を介して車輪Wに連結されている。またエンジンEがクラッチC1、C2を介して車輪Wに連結されているばかりでなく、クラッチC3を介しても車輪Wに連結されている。

このレイアウトではクラッチC3を切ると、(B)④の場合と全く同じになる。それ故、その説明は省略する。この場合のクラッチC3はエンジンEによって車輪WをモータM2に関係なく直接駆動する場合に用いられる。

このように第2図(B)の①~⑦のいずれの場合でも、駆動力をそれほど必要としない時にモータM2がエンジンEによって駆動されることによ

第3図は前述のレイアウトの具体的な動力伝達装置の一例として第2図(B)②のレイアウトに対応する動力伝達装置の断面図である。

第3図に示されているように、ハウジング31にエンジンによって駆動される駆動軸32が回転自在に支持されている。この駆動軸32には、発電可能な電動モータ33のロータ34が固定されているとともに、フライホイール35が固定されている。また歯車36が駆動軸32に回転可能に支持されており、この歯車36の右端面にはクラッチディスク37が設けられている。このクラッチディスク37は電磁コイル38の励磁によって吸引されてフライホイール35と摩擦接合するようになっている。すなわち、フライホイール35、クラッチディスク37および電磁コイル38によって電磁クラッチ39が構成されている。また、歯車36はよく知られている差動装置40の歯車41に接続されている。

このような動力伝達装置においては、電磁コイル38が励磁されて電磁クラッチ39が接続する

と、モータ33と差動装置40に接続される車輪とが連結される。したがって、モータ33が駆動すると、車輪が回転するようになる。

また電磁コイル38が励磁されないで電磁クラッチ39が切られると、モータ33と車輪との連結が解除される。したがって、モータ33の駆動力は車輪には伝達されない。一方、モータ33とエンジンとが連結されるので、モータ33をエンジンによって駆動することができるようになる。この結果、モータ33は発電機を生じる。すなわち、モータ33は発電機として機能するようになる。

この場合、モータ33は第2図(B)の②のモータM2に、電磁クラッチ39はクラッチC1に、それぞれ対応する。

第4図は前述の各モータ、クラッチおよびエンジンを制御するための制御ブロック図である。

第4図に示されているように、制御回路41には、アクセル42、ブレーキ43、車速(車両速度)44、エンジン回転数45、前後切替スイッ

を表わし、モードBは車速が所定値 $v_0$ 以上であってかつアクセル量が所定値 $a_0$ 以上のときの運転状態を表わしている。これらモードA、Bはいずれも駆動時における運転状態を表わしている。すなわち、モードAは第2図におけるレイアウトの説明で述べた低速走行時に対応する。したがって、このモードAではモータの駆動力をそれほど必要としないので、クラッチC1を切ってモータM2を車輪Wの回転駆動用としては用いなく、このモータM2をエンジンEによって駆動することにより発電機として用いる。

またモードBは第2図におけるレイアウトの説明での車両発進時、加速時および高速走行時に対応する。したがって、このモードBでは大きなモータ駆動力を必要とするので、クラッチC1を接続してモータM2を車輪Wの回転駆動用として用いる。

更にモードCは車両停止時および惰性走行時に対応する。このモードCではクラッチC1を切り、モータM2をエンジンEによって駆動することに

チ48および蓄電池電圧47の各センサからそれぞれの信号が入力される。制御回路41はこれらの信号に基づいて車両運転状態を判断してモータM1、M2 48、49、クラッチ50、エンジンスロットル制御用モータ51およびイグニッションスイッチ切断用リレー52をそれぞれ制御するためにそれらの各ドライバ48a~52aに制御信号を出力するようになっている。

制御回路41が車両の運転状態を判断するために運転状態を4つのモードに分ける。

第5図は、動力伝達系レイアウトとして第2図(A)の①および第2図(B)の②を用いて第1図(A)のように電動車両を構成した場合における車両の運転状態のモードを示した図であり、(A)は駆動時でのモードを示し、(B)は各モードにおける各モータM1、M2、エンジンEおよびクラッチC2の作動状態を示している。

モードAは車速が所定値 $v_0$ 以下の小さいときかあるいは車速が所定値 $v_0$ よりも大きいがアクセル量が所定値 $a_0$ よりも小さいときの運転状態

より発電機として用いる。更にモードDは車両減速時に対応するようになっている。このモードDではクラッチC1を接続してモータM2と車輪Wとを連結することにより、モータM2を回生ブレーキの発電機として用いる。

第6図は前述の各モードA~Dにしたがって制御回路41が行う制御のフローチャートであり、(A)はモータ、クラッチおよびエンジン等の各被制御部材に対する制御ルーチンであり、(B)はエンジンによる発電のためのサブルーチンである。

この制御フローにしたがって、第4図に示されている各被制御部材の制御を説明する。ステップ60で初期設定がされた後、ステップ61で第4図の各センサ42~47から各信号が制御装置41に入力される。

ステップ62で制御装置41はアクセル信号に基づいてアクセル量が0より大きいかな否かを判断する。アクセル量が0より大きいと判断されるとYESの方へ進み、ステップ63でアクセル量と

車速とからモードを決定する。すなわち、アクセル量が0より大きいことは車両が駆動状態であると判断されるから、モードはAかBに決定される。

ステップ84で車両の運転状態がモードAにあるか否かが判断される。モードがAであると判断されるとYESの方へ進み、ステップ85で制御装置41はクラッチC150を切る。すなわち、モータM249を車輪Wから切り離して、モータM249を発電機として用いる。

そこで、ステップ86で(B)の発電用のサブルーチンに移り、モータM249による発電が行われる。すなわち、ステップ87で蓄電池の電圧が満充電の電圧値 $\alpha$ より大きいかが判断される。電圧が値 $\alpha$ より小さいと判断されるとNOに進み、ステップ88でエンジンEが作動中であるか否かが判断される。エンジンEが作動していないと判断されるとNOに進み、ステップ89で制御装置41はモータM249によりエンジンEを駆動する。これにより、モータM249が駆動されて、モータM249は起電力を発生する。すな

わち、モータM249は発電機として機能する。

わち、モータM249は発電機として機能する。

次に、ステップ70で制御装置41はスロットル開度を所定の値となるようにエンジンスロットル制御用モータ51を制御する。更にステップ71で制御装置41はモータM249をその発電量が一定となるように制御する。モータM249によって発生した電気は蓄電池に蓄えられる。すなわち、蓄電池が充電される。このモータM249による発電は蓄電池の電圧が値 $\alpha$ よりも大きくなるまで行われる。

ステップ87で蓄電池の電圧が値 $\alpha$ より大きいと判断されると、ステップ88からステップ71までの各制御は行われない。すなわち、モータM249による発電は行われない。

発電のサブルーチンが終了すると、ステップ72でアクセル量に応じてモータM148のトルクを決定する。次に、ステップ73で前後進切替スイッチにより前後進を設定する。そして、ステップ74で制御装置41は決定されたトルクおよび前後進切替スイッチのセンサ48からの信号に

基づいてモータM148を駆動すべくモータM148のドライバ48aに信号を出力する。これにより、モータM148が駆動し、車両は発進する。アクセル量が所定値 $a_0$ を超えたとともに、車速が所定値 $v_0$ を超えると、ステップ84で運転状態がモードAではない、すなわちモードBであると判断されてNOの方に進み、ステップ75で車両が後進しているか否かが判断される。車両が後進していると判断されるとYESの方に進み、前述のようなステップ85からステップ74にしたがって制御が行われる。車両が前進していると判断されると、ステップ75でNOの方に進み、ステップ76でエンジンEが作動しているか否かが判断される。エンジンEが作動していないとNOの方に進み、ステップ77でクラッチC150を切る。

次に、ステップ78でモータM249によりエンジンEを始動する。エンジンEが始動したら、ステップ79でクラッチC150が接続される。そして、ステップ80でモータM148の駆動ト

ルクが最大に設定されてモータM148のドライバ48aに信号が出力される。これによりモータM148は最大トルクで駆動される。次に、ステップ81でアクセル量に応じてモータM249の駆動トルクおよびスロットル量が決定され、ステップ82でモータM249のドライバ48aにモータM249を駆動すべく信号が出力されるとともにステップ83でスロットルモータ51のドライバ51aにモータ51を駆動すべく信号が出力される。これにより、モータM249は決定された駆動トルクで駆動するとともに、スロットルモータ51がエンジンEのスロットル量を決定されたスロットル量にすべく駆動する。こうして、車両は加速あるいは高速走行を行うようになる。

ステップ76でエンジンEが作動しているとYESの方に進んで、前述のようなステップ79からステップ83までの制御が行われる。

ステップ82でアクセル量が0であるとNOに進み、ステップ84でブレーキ量が0より大きいかが判断される。ブレーキ量が0であると判

断されると、NOに進んで車両走行状態がモードCにあると判断され、ステップ85でクラッチC150が切られる。

次いで、ステップ88で前述のような発電のためのサブルーチンが行われる。すなわち、モータM249はエンジン駆動による発電を行う。発電のルーチンが終了すると、ステップ87でモータM148のトルクが0となるようにモータM148のドライバ48aに信号が出力される。こうして、モータM148の駆動トルクが0とされ、車両は惰性走行状態または停止状態となる。

ステップ84でブレーキ量が0より大きいと判断されるとYESの方に進み、車両走行状態がモードDであると判断され、ステップ88でイグニッションスイッチを切断すべくイグニッションスイッチ切断用リレー52のドライバ52aに信号が出力される。これにより、イグニッションスイッチが切れ、エンジンEが停止する。

次いで、ステップ89でクラッチC150が接続され、ステップ90でブレーキ量に応じてモー

のモードを設定することができる。

#### (発明の効果)

以上の説明から明らかなように、本発明による電動車両における蓄電池の充電装置は、車両推進のために大きな駆動力が必要ときには複数の電動モータのすべての駆動力によってすべての車輪を回転駆動し、車両推進のために駆動力がそれほど必要でないときには複数の電動モータのうち少なくとも一つを車輪から切り離すとともに発電用エンジンでこのモータを駆動することにより、そのモータに発電させるようにしているので、エンジンによって蓄電池が効果的に充電される。したがって、蓄電池の放電深度を小さくすることができるようになり、蓄電池の寿命を延ばすことができるようになる。

また、電動車両が走行するときには蓄電池が必ず充電されることになるので、蓄電池の容量をそれほど大きくしなくても済むようになる。したがって、蓄電池のエネルギー密度が小さくてもよいことになるので、蓄電池はパワー密度の大きな蓄電

モータM148およびモータM249の回生力を決定する。そして、ステップ91で決定された回生力に基づいてモータM148およびモータM249の各ドライバ48a、49aに信号が出力される。こうして、モータM148およびモータM249は車両減速時における回生ブレーキの発電機として機能することになり、モータM148およびモータM249は起電力を発生するようになる。

なお、前述の実施例においては、電動車両の駆動力伝達系のレイアウトを、前輪側には第2図(A)の①のレイアウトを採用し、後輪側には第2図(B)の②のレイアウトを採用するものとしているが、本発明はこれに限定されるものではなく、他のレイアウトを採用することもできる。その場合には、前述のように各モータM1、M2の発電効率、クラッチ等の部品点数あるいは構造の単純化等を考慮しながら使用目的に応じて適宜選択するようにすればよい。

また運転状態を特徴づける各モードの設定も更に細かくしたりあるいは粗くしたりするなど種々

池を使用することができる。

更に、容量を小さくすることができることにより蓄電池をコンパクトにすることができるようになるので、蓄電池の重量を軽減することができるばかりでなく、車体への設置スペースを小さくすることができる。

#### 4. 図面の簡単な説明

第1図は本発明に係る電動車両における蓄電池の充電装置の電動モータ、発電用エンジンおよび蓄電池の配置を示し、(A)～(C)はこの配置のそれぞれ異なる例を説明する説明図、第2図は駆動力伝達系のレイアウトを示し、(A)は発電用エンジンが付いていない場合のスキマティック図であり、(B)は発電用エンジンが付いている場合のスキマティック図、第3図は第2図(B)の②のレイアウトに対応する動力伝達装置の断面図、第4図は本発明に係る電動車両における蓄電池の充電装置を制御するための制御ブロック図、第5図は、動力伝達系レイアウトとして第2図(A)の①および第2図(B)の②を用いて第1図(A)

のように電動車両を構成した場合における車両の運転状態のモードを示し、(A)は駆動時のモードを、(B)は各モードにおける各モータM<sub>1</sub>、M<sub>2</sub>、エンジンEおよびクラッチCの作動状態をそれぞれ示す図、第8図は前述の各モードに基づいて行う制御のフローチャートであり、(A)はモータ、クラッチおよびエンジン等の各被制御部材に対する制御ルーチンを示し、(B)はエンジンによる発電のためのサブルーチンを示す図である。

48...電動モータM<sub>1</sub>、49...電動モータM<sub>2</sub>、50...クラッチC

特許出願人 アイシン・エイ・ダブリュ株式会社  
(外1名)

代理人弁理士 青木 健二 (外5名)

第1図

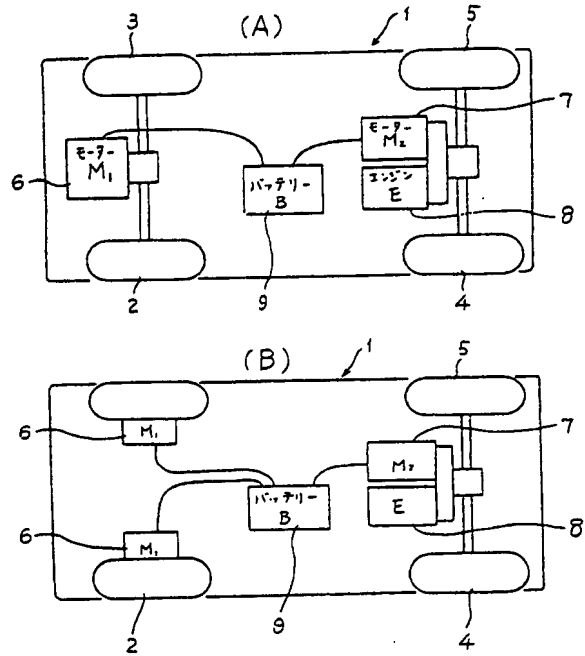

第5図

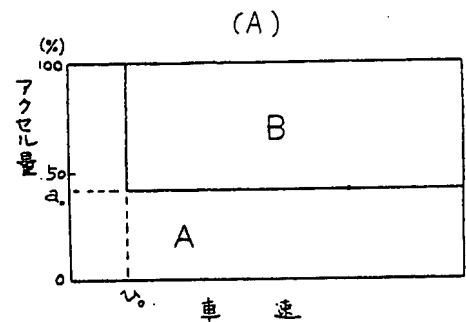

第1図

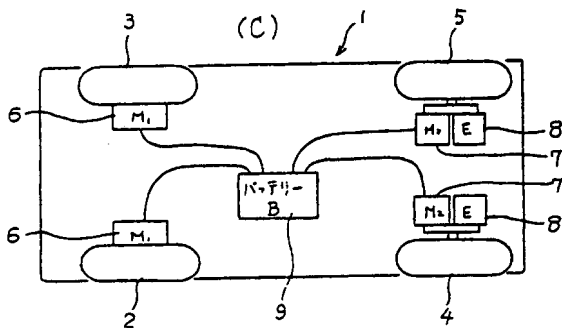

(B)

モード	A	B	C	D
M <sub>1</sub>	○	○	×	G <sub>B</sub>
E	○	○	○	×
M <sub>2</sub>	G <sub>E</sub>	○	G <sub>E</sub>	G <sub>B</sub>
C	×	○	×	○

○は作動条件、×は非作動条件  
G<sub>E</sub>はエンジンによる発電  
G<sub>B</sub>は回生ブレーキによる発電

第 2 図

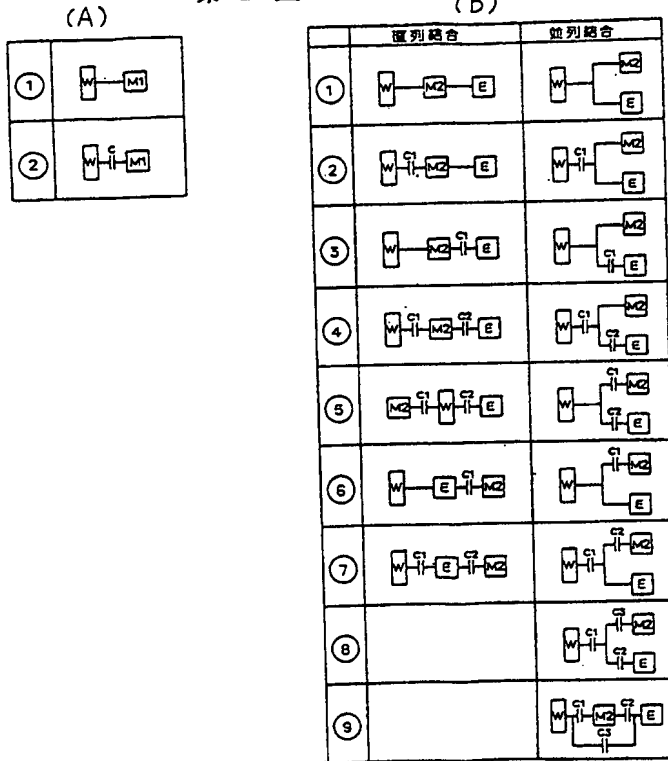

第 3 図

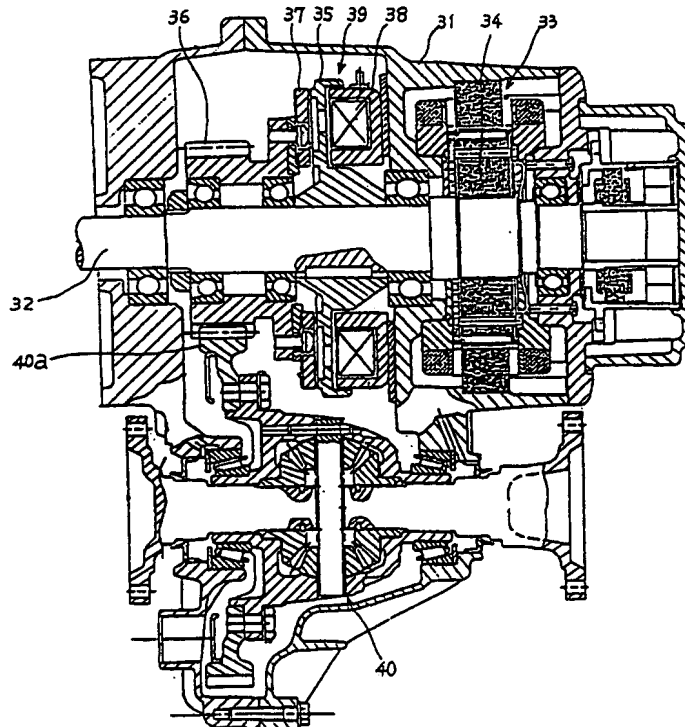

第 4 図

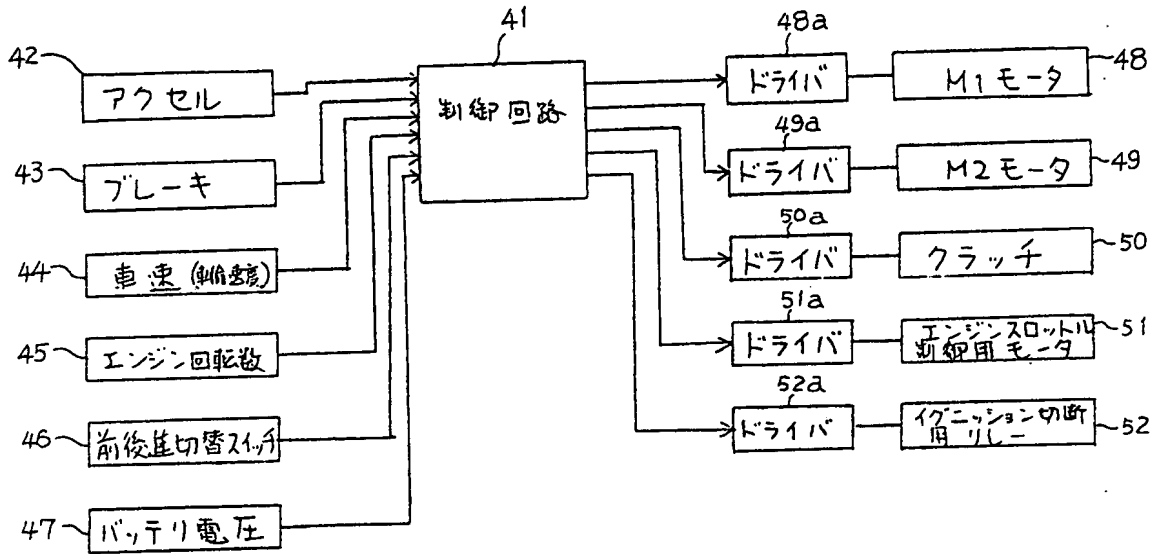

第 6 図

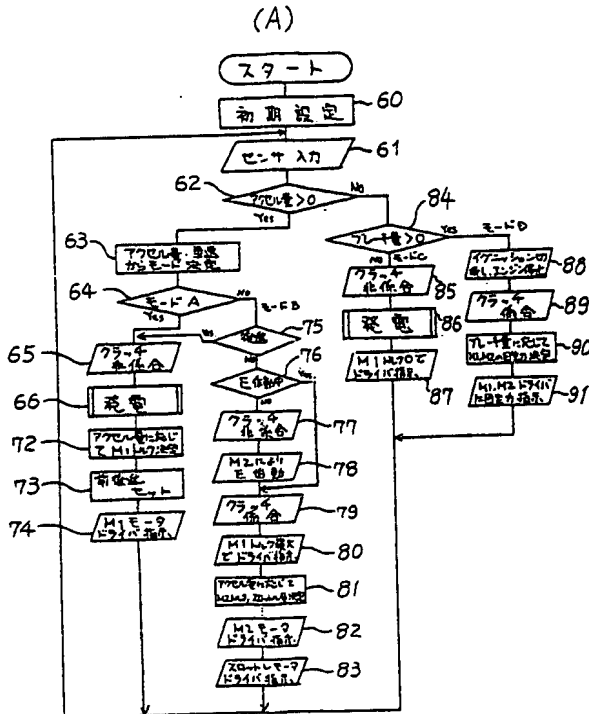

第 6 図

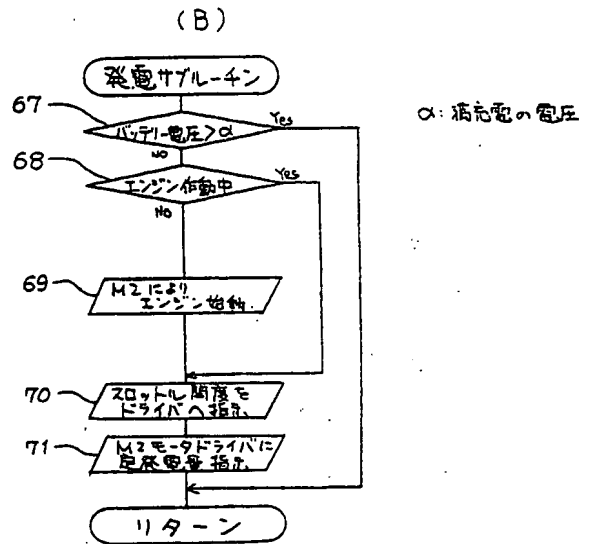

α: 満充電の電圧

手続補正書

平成 1年 12月 27日

特許庁長官 吉田 文 毅 殿

1. 事件の表示 昭和63年特許願第253385号

2. 発明の名称 電動車両における蓄電池の充電装置

3. 補正をする者  
事件との関係 特許出願人  
住所 愛知県安城市藤井町高根10番地  
名称 アイシン・エイ・ダブリュ株式会社  
代表者 諸戸 脩三 (外1名)

4. 代理人  
住所 東京都台東区上野1丁目18番11号  
西楽堂ビル(7階) 特許事務所  
氏名 (9478) 弁理士 青木 健 (外5名)

5. 補正命令の日付  
起案日 昭和64年 1月 6日  
発送日 平成 1年 1月 31日

6. 補正の対象  
図面の第3図

7. 補正の内容  
別紙の通り



第 3 図

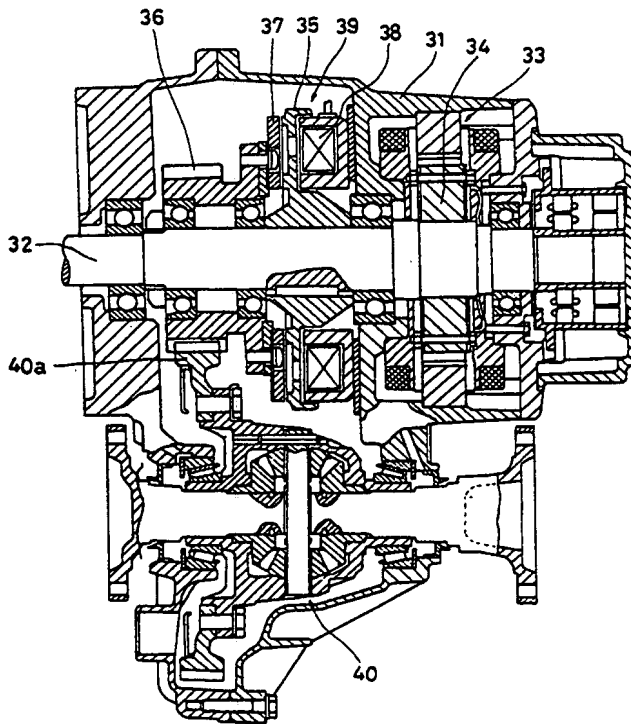



[Date of requesting appeal against examiner's decision of rejection]

[Date of extinction of right]

(Embodiment)

Embodiments of the present invention will be described below with reference to the drawings.

FIG. 1 shows the arrangement of front and rear and right and left wheels, electric motors, generator engine and a secondary battery of an electric vehicle of the present invention, and FIGS. 1A through 1C are illustrations for explaining different examples of this arrangement, respectively. It is to be noted that, in FIGS. 1A through 1C, the same reference numerals designate the same constituents in order to avoid redundant explanation.

In the arrangement example shown in FIG. 1A, an electric vehicle 1 is equipped with a right and left pair of front wheels 2 and 3 and rear wheels 4 and 5. The front wheels 2 and 3 are rotationally driven by one electric motor M1 6, and the rear wheels 4 and 5 are rotationally driven by one electric motor M2 7 and at the same time, are rotationally driven by an engine E 8. This engine 8 also rotationally drives the electric motor 7. The two electric motors 6 and 7 are connected to a secondary battery 9, respectively.

In addition, in the arrangement example shown in FIG. 1B, the arrangement differs from FIG. 1A only in that the front wheels 2 and 3 are rotated by different electric motors M1 6 and 6, respectively.

Also in this case, the two electric motors 6 and 6 which rotate the front wheels 2 and 3 are connected to the secondary battery 9.

Furthermore, in the arrangement example shown in FIG. 1C, the arrangement differs from FIG. 1B in that the rear wheels 4 and 5 are rotated by different electric motors M2 7 and 7, and also by different engines 8 and 8, respectively. Also in this case, both the engines 8 and 8 rotate the corresponding electric motors 7 and 7, respectively. Both the electric motors 7 and 7 are connected to the secondary battery 9, too.

FIG. 2 shows the layout of the driving force transmission system, and FIG. 2A is a schematic diagram when no generator engine is equipped and FIG. 2B is a schematic diagram when a generator engine is equipped.

What is shown in [1] of FIG. 2A is that the electric motor M1 is directly connected to a wheel W. In such event, since the electric motor M1 and the wheel W are connected to each other at all times, the wheel W is unable to be set free.

In addition, what is shown in [2] of FIG. 2A is that the electric motor M1 is connected to the wheel W via a clutch C. In such event, by disconnecting the clutch C, the wheel W can be set free. Consequently, for example, when the driving force is lost during traveling, disconnecting the clutch C makes the wheel W and the electric motor M1 independent of each other, and the inertia of the motor M1 is not exerted on the wheel W. In addition, even in the event that the wheel is in the standstill state, the electric motor M1 can be maintained in the operating state.

The electric motor M1 in such event is used only for rotationally driving the wheel W in order to propel a vehicle except when it is used as a generator for regenerative braking at the time of decelerating the vehicle.

As shown in FIG. 2B, cases in which the electric motor M2 and generator engine E are connected in series with respect to the wheel W and in which they are connected in parallel, are shown. The serial connection and parallel connection differ only in the connection form and are practically the same from the viewpoint of driving force transmission.

What is shown in [1] of FIG. 2B is that the electric motor M2 and the generator engine E are directly connected to the wheel W, and at the same time the motor M2 and the generator engine E are directly connected to each other.

In this layout, at the time of vehicle start when comparatively large driving force is required, the electric motor M2 is used for rotationally driving the wheel W. In such event, when a large driving force is required, the driving force of the generator engine E can be added. In the same manner, at the time of acceleration and high-speed traveling, the motor M2 is used for rotationally driving the wheel W.

At the time of low-speed traveling where a large driving force is not required, the electric motor M2 need not be used for rotationally driving the wheel W. Therefore, by rotating this motor M2 by the engine E, the motor M2 is allowed to generate power. That is, at the time of low-speed traveling, the motor M2 is used as a generator. In this way, power generation by the engine E can be carried out. However, in such event, since both the engine E and motor M2 are directly connected to the wheel W, the revolution number of the engine E is determined by the vehicle speed, that is, revolution number of the wheel W. Consequently, it is impossible to use the

engine E always in a region with good combustion efficiency.

In addition, because the wheel W stops when the vehicle is stopped, both the motor M2 and engine E cannot be operated, and power generation is disabled. Furthermore, because during coasting, both the motor M2 and engine E merely perform coasting rotation, power generation is nearly impossible.

On the other hand, the electric motor M2 is used as a power generator of regenerative braking at the time of vehicle deceleration. In such event, since the engine E is directly connected to the motor M2, the regeneration amount is decreased in accordance with the loss caused by the engine brake.

Furthermore, because in starting the engine, the wheel W is stopped, it is impossible to start the engine E from the vehicle stopping condition.

This layout has no clutch, and therefore, it has an advantage that not only the number of components is decreased but also a simple construction can be achieved.

What is shown in [2] of FIG. 2B is that the motor M2 and the engine E are connected via the clutch C1. As is the case of [1] of FIG. 2B, the motor M2 and the engine E are directly connected to each other.

When the vehicle starts, is accelerated, or travels at a high speed, by connecting the clutch C1, the motor M2 is used for rotationally driving the wheel W. That is, connecting the clutch C1 directly connects the motor M2 and the engine E to the wheel W, and exactly the same case as [1] of FIG. 2B described above is achieved.

When the vehicle is traveling at a low speed, is stopped, or is coasting, a large driving force is not required, and therefore, disconnecting the clutch C1 can disconnect the motor M2 from the wheel W. Consequently, the motor M2 is not used for rotationally driving the wheel W. Then, the motor M2 generates the electromotive force by being rotationally driven by the engine E. That is, the motor M2 is used as a generator. In such event, since the motor M2 and the engine E are being disengaged from the wheel W, effects of rotation of the wheel W are not exerted on the rotation of the engine E. In this way, the region with good combustion efficiency of the engine E becomes always available. Consequently, the secondary battery can be efficiently charged.

When the vehicle is decelerated, connecting the clutch C1 enables the motor M2 to function as a generator for

regenerative braking. In such event, as is the case of [1] of FIG. 2B, the engine E and the motor M2 are directly connected, and thus the regeneration amount is decreased in accordance with the loss caused by the engine brake.

Furthermore, when the engine is started, by disconnecting the clutch C1 to disconnect the motor M2 and the engine E from the wheel W, the engine E can be started by the motor M2. Consequently, in such event, no starter motor for driving the engine is required.

What is shown in [3] of FIG. 2B is that the motor M2 is directly connected to the wheel W but the engine E is connected to the wheel W and the motor M2 via the clutch C1.

In this layout, by connecting the clutch C1, exactly the same case as that of [1] of FIG. 2B is obtained. Therefore, the description will be omitted regarding when the vehicle is started, is accelerated, and travels at high or low speed where the clutch C1 is connected.

On the other hand, when the vehicle is stopped, the motor M2 is cannot be driven and, during coasting, the motor M2 merely performs coasting rotation, and thus exactly the same case as that of [1] of FIG. 2B is achieved, too.

Furthermore, when the vehicle is decelerated, the motor M2 functions as a generator for regenerative braking. In such event, disconnecting the clutch C1 to disconnect the wheel W and the motor M2 from the engine E prevents the engine brake from functioning, and loss caused by the engine brake is not generated. Consequently, the regeneration amount is not decreased and the power generation amount nearly equivalent to that of a conventional electric car can be obtained.

Furthermore, when the engine E is started, disconnecting the clutch C1 disconnects the motor M2 and the engine E, and therefore the motor M2 cannot drive the engine E. Consequently, a starter motor must be equipped. In addition, connecting the clutch C1 directly connects the motor M2, the engine E and the wheel W to each other, and exactly the same case as that of [1] of FIG. 2B is achieved. That is, the engine E cannot be started from the vehicle standstill condition.

What is shown in [4] of FIG. 2B is that the motor M2 is connected via the clutch C1 and at the same time, the engine E is connected via two clutches C1 and C2. In addition, the motor M2 and the engine E are connected via the clutch C2.

Consequently, in this layout, one additional clutch is provided.

When the vehicle is started, is accelerated, or travels at high speed, connecting the clutch C1 allows the motor M2 to be used for rotationally driving the wheel W. In addition, connecting both the clutches C1 and C2 connects the motor M2 and the engine E directly to the wheel W, and therefore, exactly the same case as that of [1] of FIG. 2B is achieved. Consequently, the description thereof is omitted.

At the time of low-speed traveling, by disconnecting the clutch C1 and connecting the clutch C2, the motor M2 can be used as a generator. That is, driving the motor M2 by the engine E causes the motor M2 to generate the electromotive force, and power generation by the engine E becomes available. Furthermore, since the clutch C1 is disconnected and the wheel W is disconnected from the motor M2 and engine E, as is the case of [2] of FIG. 2B, rotation of the engine E is not susceptible to rotation of the wheel W. Consequently, the engine E can be used always in the region with good combustion efficiency for power generation.

In addition, when the vehicle is stopped or coasting, disconnecting the clutch C1 and connecting the clutch C2 connect the motor M2 to the engine E and at the same time, disengage these from the wheel W. This enables the motor M2 to be driven by the engine E, and thereby power generation is performed. In such event, too, as is the case of [2] of FIG. 2B, the engine E can be used always in the region with good combustion efficiency for power generation.

Furthermore, when the vehicle is decelerated, by connecting the clutch C1 and disconnecting the clutch C2, as is the case of [3] of FIG. 2B, the motor M2 can be used as a generator for regenerative braking. In such event, too, since the regeneration amount is not decreased due to the loss caused by the engine brake, the motor M2 carries out power generation equivalent to that of a conventional electric car.

Furthermore, when the engine is started, disconnecting the clutch C1 and connecting the clutch C2 disconnect the motor M2 from the wheel W and connect the motor M2 to the engine E. Consequently, in such event, the same case as that of [2] of FIG. 2B is achieved. In this way, irrespective of the wheel W, the motor M2 can be driven by the engine E, and the engine E can be started from the vehicle standstill condition. As a

result, no starter motor for driving the engine E is required.

What is shown in [5] of FIG. 2B is that the motor M2 is connected to the wheel W via the clutch C1 and at the same time, the engine E is connected to the wheel W via the clutch C2.

When the vehicle is started, is accelerated, or travels at high speed, by connecting the clutch C1, the motor M2 can be used for rotationally driving the wheel W. In addition, connecting both the clutches C1 and C2 directly connects the motor M2 and the engine E to the wheel W, and the same case as that of [1] of FIG. 2B is achieved.

Furthermore, when the motor M2 is used as a generator for power generation by the engine E while traveling at a low speed, both the clutches C1 and C2 are connected, and therefore, the same case as that of [1] of FIG. 2B is achieved. Consequently, the description is omitted for these cases.

In addition, when the vehicle is stopped or coasting, disconnecting both the clutches C1 and C2 to prevent the driving force of the motor M2 and the engine E from being transmitted to the vehicle W prevents the motor M2 and the engine E from being connected. Consequently, because the motor M2 cannot be driven by the engine E, the motor M2 does not carry out power generation.

When the vehicle is decelerated, by connecting the clutch C1 and disconnecting the clutch C2, the motor M2 and the wheel W are directly connected. Consequently, the case becomes the same as that of [3] of FIG. 2B, and the description thereof is omitted.

When the engine is started, connecting both the clutches C1 and C2 to drive the engine E by the motor M2 achieves the same case as that of [1] of FIG. 2B. Therefore, disconnecting the clutch C2 to disconnect the engine E from the vehicle W achieves the same case as that of [3] of FIG. 2B. Consequently, a starter motor is additionally required.

What is shown in [6] of FIG. 2B is that the engine E is directly connected to the wheel W and at the same time the motor M2 is connected to the wheel W via the clutch C1.

In this layout, connecting the clutch C1 achieves the same case as that of [1] of FIG. 2B. Consequently, when the vehicle is started, is accelerated, travels at high speed, travels at low speed, and is decelerated and when the engine is started, the clutch C1 is connected, and therefore, exactly the same

case as that of [1] of FIG. 2B is achieved. Therefore, the description thereof is omitted.

Because the engine E is directly connected to the wheel W when the vehicle is stopped, the engine E stops and power generation by the engine E is not performed. In addition, during coasting, the engine E merely performs coasting rotation. Therefore, whether the clutch C1 is connected or not, the motor M2 is not rotated to rotation sufficient for the engine E to generate power.

What is shown in [7] of FIG. 2B is that the engine E is connected to the wheel W via the clutch C1 and at the same time, the motor M2 is connected to the wheel W via the clutches C1 and C2. In addition, the motor M2 and the engine E are connected via the clutch C2.

In this layout, connecting both the clutches C1 and C2 achieves the same case as that of [1] of FIG. 2B. Consequently, when the vehicle is started, is accelerated, travels at high speed, and is decelerated, both the clutches C1 and C2 are connected, and therefore, exactly the same case as that of [1] of FIG. 2B is achieved. Therefore, the description thereof is omitted.

In addition, disconnecting the clutch C1 and connecting the clutch C2 in such event produces the same case as that of [4] of FIG. 2B. Consequently, when the vehicle travels at low speed, is stopped or is coasting, and when the engine is started, the clutch C1 is disconnected and the clutch C2 is connected, and therefore, exactly the same case as that of [4] of FIG. 2B is achieved. Consequently, the description thereof is omitted.

What is shown in [8] of FIG. 2B is that the motor M2 is connected to the wheel W via clutches C1 and C3 and at the same time, the engine E is connected to the wheel W via the clutches C1 and C2. In addition, the motor M2 and the engine E are connected via the clutch C2.

In this layout, connecting all the clutches C1, C2, and C3 achieves the same case as that of [1] of FIG. 2B. Consequently, when the vehicle starts, is accelerated, and travels at high speed, the clutches C1, C2, and C3 are connected, and exactly the same case as that of [1] of FIG. 2B is achieved. Therefore, the description thereof is omitted.

In addition, in such event, disconnecting the clutch C1 and connecting the clutches C2 and C3 achieves the same case as



that of [4] of FIG. 2B. Consequently, when the vehicle travels at low speed, stops or is coasting, and when the engine starts, the clutch C1 is disconnected and the clutches C2 and C3 are connected and exactly the same case as that of [4] of FIG. 2B is achieved. Therefore, the description thereof is omitted.

Furthermore, connecting the clutches C1 and C3 and disconnecting the clutch C2 in this event achieves the same case as that of [3] of FIG. 2B. Consequently, when the vehicle is decelerated, the clutches C1 and C3 are connected and the clutch C2 is disconnected, and therefore exactly the same case as that of [3] of FIG. 2B is achieved. Consequently, the description thereof is omitted.

What is shown in [9] of FIG. 2B is that the motor M2 is connected to the wheel W via the clutch C1. In addition, the engine E is not only connected to the wheel W via the clutches C1 and C2 but also connected to the wheel W via the clutch C3.

This layout is exactly the same as that of [4] of FIG. 2B if the clutch C3 is disconnected. Therefore, the description thereof is omitted. The clutch C3 in this event is used to directly drive the wheel W by the engine E irrespective of the motor M2.

As described above, in all the cases of [1] through [9] of FIG. 2B, the motor M2 generates the electromotive force by the motor M2 being driven by the engine E when the driving force is not so much required. That is, the motor M2 functions as a generator. Consequently, connecting this motor M2 to the secondary battery can charge the secondary battery by power generation by the engine E. In particular, the layouts [2], [4], [7], [8], and [9] of FIG. 2B, in which the engine E can be used always in a region with good combustion efficiency, can effectively charge the secondary battery. However, in these driving force transmission layouts, one to three clutches are disposed. Thus, not only the number of components increases but also the construction may be complicated. Consequently, the layout should be chosen accordingly depending on the intended use.

On the other hand, even when the vehicle is decelerated, the motor M2 functions as a generator of regenerative braking. In such event, the cases [3], [4], [5], [8], and [9] of FIG. 2B enable the motor M2 to generate power particularly effectively. Consequently, it is desirable to select the layout with the regenerative braking power generation amount taken into

account.

FIG. 3 is a cross-sectional view of a power transmission device corresponding to the layout of [2] of FIG. 2B as one example of a specific power transmission device of the above layout.

As shown in FIG. 3, a drive shaft 32 driven by an engine is rotatably supported with a housing 31. To this drive shaft 32, a rotor 34 of a power-generative electric motor 33 is fixed and at the same time, a flywheel 35 is fixed. In addition, a gear 36 is rotatably supported with the drive shaft 32, and on the right end face of this gear 36, a clutch disk 37 is installed. This clutch disk 37 is attracted by excitation of an electromagnetic coil 38 and is friction-bonded to the flywheel 35. That is, an electromagnetic clutch 39 is composed of the flywheel 35, clutch disk 37, and electromagnetic coil 38. In addition, the gear 36 is connected to a gear 41 of a well-known differential arrangement 40.

In this kind of power transmission device, when the electromagnetic clutch 39 is connected by exciting the electromagnetic coil 38, the motor 33 and a wheel connected to the differential arrangement 40 are connected. Consequently, when the motor 33 is driven, the wheel rotates.

When the electromagnetic coil 38 is not excited and the electromagnetic clutch 39 is disconnected, the connection between the motor 33 and the wheel is released. Consequently, the driving force of the motor 33 is not transmitted to the wheel. On the other hand, because the motor 33 and the engine are connected, the motor 33 can be driven by the engine. As a result, the motor 33 generates the electromotive force. That is, the motor 33 functions as a generator.

In such event, the motor 33 corresponds to the motor M2 of [2] of FIG. 2B and the electromagnetic clutch 39 to the clutch C1, respectively.

FIG. 4 is a control block diagram for explaining control of each motor, clutch, and engine mentioned above.

As shown in FIG. 4, to the control circuit 41, signals are input from each sensor of an accelerator 42, brake 43, car speed (vehicle speed) 44, engine revolution number 45, forward/backward selector switch 46, and secondary battery voltage 47. The control circuit 41 outputs control signals to each of the drivers 48a through 52a in order to judge the vehicle operating condition in accordance with these signals

and control motors M1 48, M2 49, clutch 50, engine throttle control motor 51 and ignition switch disconnecting relay 52, respectively.

The operating condition is divided into four modes in order for the control circuit 41 to judge the vehicle operating condition.

FIG. 5 is the drawing that shows the mode of the vehicle operating condition when the electric vehicle is configured as is the case of FIG. 1A using [1] of FIG. 2A and [2] of FIG. 2B as a driving force transmission system layout, and FIG. 5A shows the mode at the time of driving and FIG. 5B shows the operating condition of each motor M1, M2, engine E and clutch C2 in each mode.

The mode A shows the operating condition when the vehicle speed is equal to or smaller than a predetermined value  $v_0$ , or the vehicle speed is larger than predetermined value  $v_0$  but the acceleration amount is smaller than a predetermined value  $a_0$ . The mode B shows the operating condition when the vehicle speed is equal to or larger than the predetermined value  $v_0$  and the acceleration amount is equal to or larger than the predetermined value  $a_0$ . Both these modes A and B show the operating conditions at the time of driving. That is, the mode A corresponds to the low-speed travel time discussed in the description of layout in FIG. 2. Consequently, because in this mode A, a large driving force is not required, the clutch C1 is disconnected, and the motor M2 is not used for rotationally driving the wheel W but is used as a generator by driving this motor M2 by the engine E.

In addition, the mode B corresponds to the time of vehicle start, acceleration, and high-speed travel in the description of the layout in FIG. 2. Consequently, because in this mode B, a large motor driving force is required, the clutch C1 is connected and the motor M2 is used for rotationally driving the wheel W.

Furthermore, the mode C corresponds to the time of vehicle stop and coasting. In this mode C, by disconnecting the clutch C1 and driving the motor M2 by the engine E, the motor M2 is used as a generator. Furthermore, the mode C corresponds to the time of vehicle deceleration. In this mode D, by connecting the clutch C1 to connect the motor M2 to the wheel W, the motor M2 is used as a generator for regenerative braking.

FIG. 6 is a flow chart of control carried out by the control circuit 41 in accordance with each of the modes A through D, and FIG. 6A shows a control routine for each controlled member such as motor, clutch, and engine, while FIG. 6B shows a sub-routine for power generation by an engine.

Following this control flow, control of each controlled member shown in FIG. 4 will be described. After initial setting is carried out in step 60, in step 61, signals from each of sensors 42 through 47 in FIG. 4 are input to the controller 41.

In step 62, the controller 41 judges whether or not the acceleration amount is greater than zero in accordance with the acceleration signals. When the acceleration amount is judged to be larger than zero, the flow advances to YES, and in step 63, the mode is determined from the acceleration amount and the vehicle speed. That is, since it is judged that the vehicle is in the driving condition when the acceleration amount is greater than zero, the mode is determined to be A or B.

In step 64, it is judged whether or not the vehicle operating condition is in mode A. When the mode is judged to be A, the flow advances to YES, and in step 65, the controller 41 disconnects the clutch C1 50. That is, the motor M2 49 is disconnected from the wheel W and the motor M2 49 is used as a generator.

Now, in step 66, the flow moves to the sub-routine for power generation of FIG. 6B and power generation by the motor M2 49 is performed. That is, in step 67, it is judged whether or not the secondary battery voltage is greater than the voltage value  $\alpha$  at full charge. If the voltage is judged to be smaller than the value  $\alpha$ , the flow advances to NO, and it is judged in step 68 whether or not the engine E is in operation. If it is judged that the engine E is not in operation, the flow moves to NO and in step 69, the controller 41 drives the engine E by the motor M2 49. In this manner, the motor M2 49 is driven and the motor M2 49 generates the electromotive force. That is, the motor M2 49 functions as a generator.

Then, in step 70, the controller 41 controls the engine throttle control motor 51 so that the throttle opening becomes a predetermined value. Furthermore, in step 71, the controller 41 controls the motor M2 49 in such a manner that a constant power generation is achieved. The electric power generated by the motor M2 49 is stored in the secondary battery. That is,

the secondary battery is charged. The power generation by this motor M2 49 is performed until the secondary battery voltage exceeds the value  $\alpha$ .

When the secondary battery voltage is judged in step 67 to be larger than the value  $\alpha$ , control from step 68 to step 71 is not performed. That is, power generation by the motor M2 49 is not performed.

When the power generation sub-routine is completed, in step 72, the torque of the motor M1 48 is determined in accordance with the acceleration amount. Then, in step 73, forward or backward travel is set by the forward/backward selector switch. In step 74, based on the torque determined and the signal from the sensor 46 of the forward/backward selector switch, the controller 41 outputs signals to the driver 48a of the motor M1 48 to drive the motor M1 48. In this manner, the motor M1 48 is driven and the vehicle starts.

When the acceleration amount exceeds the predetermined value  $a_0$  and at the same time the vehicle speed exceeds the predetermined value  $v_0$ , in step 64, the operating condition is judged not to be mode A, that is, to be mode B, and the flow goes to NO, and in step 75, it is judged whether or not the vehicle is traveling backward. When the vehicle is judged to be traveling backward, the flow goes to YES, and control is carried out in accordance with step 65 to step 74 as described above. When the vehicle is judged to be traveling forward, in step 75, the flow goes to NO and in step 76, it is judged whether or not the engine E is being operated. When the engine E is not operated, the flow goes to NO and in step 77, the clutch C1 50 is disconnected.

Then, in step 78, the engine E is started by the motor M2 49. When the engine E starts, in step 79, the clutch C1 50 is connected. In step 80, the driving torque of the motor M1 48 is set to the maximum and signals are output to the driver 48a of the motor M1 48. By this operation, the motor M1 48 is driven at the maximum torque. Then, in step 81, the driving torque of the motor M2 49 and the throttle amount are determined in accordance with the acceleration amount, and in step 82, signals to drive the motor M2 49 are output to the driver 49a of the motor M2 49 and at the same time, in step 83, signals to drive the motor 51 are output to the driver 51a of the throttle motor 51. By this operation, the motor M2 49 is driven at the determined driving torque and at the same time,

the throttle motor 51 is driven in such a manner that the throttle amount of the engine E achieves the determined throttle amount. In this way, the vehicle carries out acceleration or high-speed traveling.

When the engine E is operated in step 76, the flow goes to YES, and control from step 79 to step 83 as described above is carried out.

When the acceleration amount is zero in step 62, the flow goes to NO, and it is judged in step 84 whether or not the brake amount is greater than zero. When the brake amount is judged to be zero, the flow goes to NO and the vehicle travel condition is judged to be in the mode C, and in step 85, the clutch C1 50 is disconnected.

Then, in step 86, the sub-routine for power generation as described above is performed. That is, the motor M2 49 generates power by engine drive. When the power generation routine is completed, in step 87, signals are output to the driver 48a of the motor M1 48 so that the torque of the motor M1 48 is zero. In this way, the driving torque of the motor M1 48 is set to zero and the vehicle enters the coasting state or the stop state.

When the brake amount is judged to be larger than zero in step 84, the flow goes to YES, and the vehicle travel state is judged to be in the mode D and in step 88, signals are output to the driver 52a of the ignition switch disconnecting relay 52 to turn off the ignition switch. By this operation, the ignition switch is turned off and the engine E stops.

Then, in step 89, the clutch C1 50 is connected, and the regenerative force of the motor M1 48 and the motor M2 49 is determined in accordance with the brake amount in step 90. And in step 91, based on the determined regenerative force, signals are output to each driver 48a and 49a of the motor M1 48 and the motor M2 49. In this way, the motor M1 48 and the motor M2 49 function as a generator for regenerative braking at the time of vehicle deceleration, and the motor M1 48 and the motor M2 49 generate electromotive force.

It is to be noted that, in the above-mentioned embodiment, for the layout of the driving force transmission system of the electric vehicle, the layout of [1] of FIG. 2A is adopted for the front wheel side, and the layout of [2] of FIG. 2B is adopted for the rear wheel side, but the present invention should not be restricted by this but other layouts can be

adopted. In such event, the layout should be chosen adequately in accordance with the intended use with the power generation efficiency of the motors M1 and M2, the number of components such as clutch, etc., or simplification of the structure, etc. taken into account as described above.

Furthermore, for setting of each mode which characterizes the operating condition, various modes may be set by further refining or further roughening the setting.

#### 4. BRIEF DESCRIPTION OF THE DRAWINGS

FIG. 1 shows arrangement of electric motors for a battery charger for a secondary battery, a generator engine, and a secondary battery in an electric vehicle according to the present invention, wherein

FIGS. 1A through 1C are illustrations for explaining different examples of this arrangement, respectively;

FIG. 2 shows a layout of a driving force transmission system, wherein

FIG. 2A is a schematic diagram when the generator engine is not equipped, and

FIG. 2B is a schematic diagram when the generator engine is equipped;

FIG. 3 is a cross-sectional view of a power transmission device corresponding to the layout of [2] of FIG. 2B;

FIG. 4 is a control block diagram for controlling a battery charger of a secondary battery in an electric vehicle according to the present invention;

FIG. 5 shows the mode of vehicle operating condition when an electric vehicle is configured as shown in FIG. 1A using [1] of FIG. 2A and [2] of FIG. 2B as power transmission system layouts, wherein

FIG. 5A shows the mode at the time of driving, and

FIG. 5B shows the operating condition of each motor M1, M2, engine E and clutch C2 in each mode, respectively;

FIG. 6 is a flow chart of control conducted on the basis of each mode described above, wherein

FIG. 6A shows a control routine for each controlled member such as a motor, clutch, and engine, and

FIG. 6B is a drawing that shows a sub-routine for power generation by the engine.

48 Electric motor M1

JP02-101903A partial translation

49 Electric motor M2

50 Clutch C1



FIG. 1

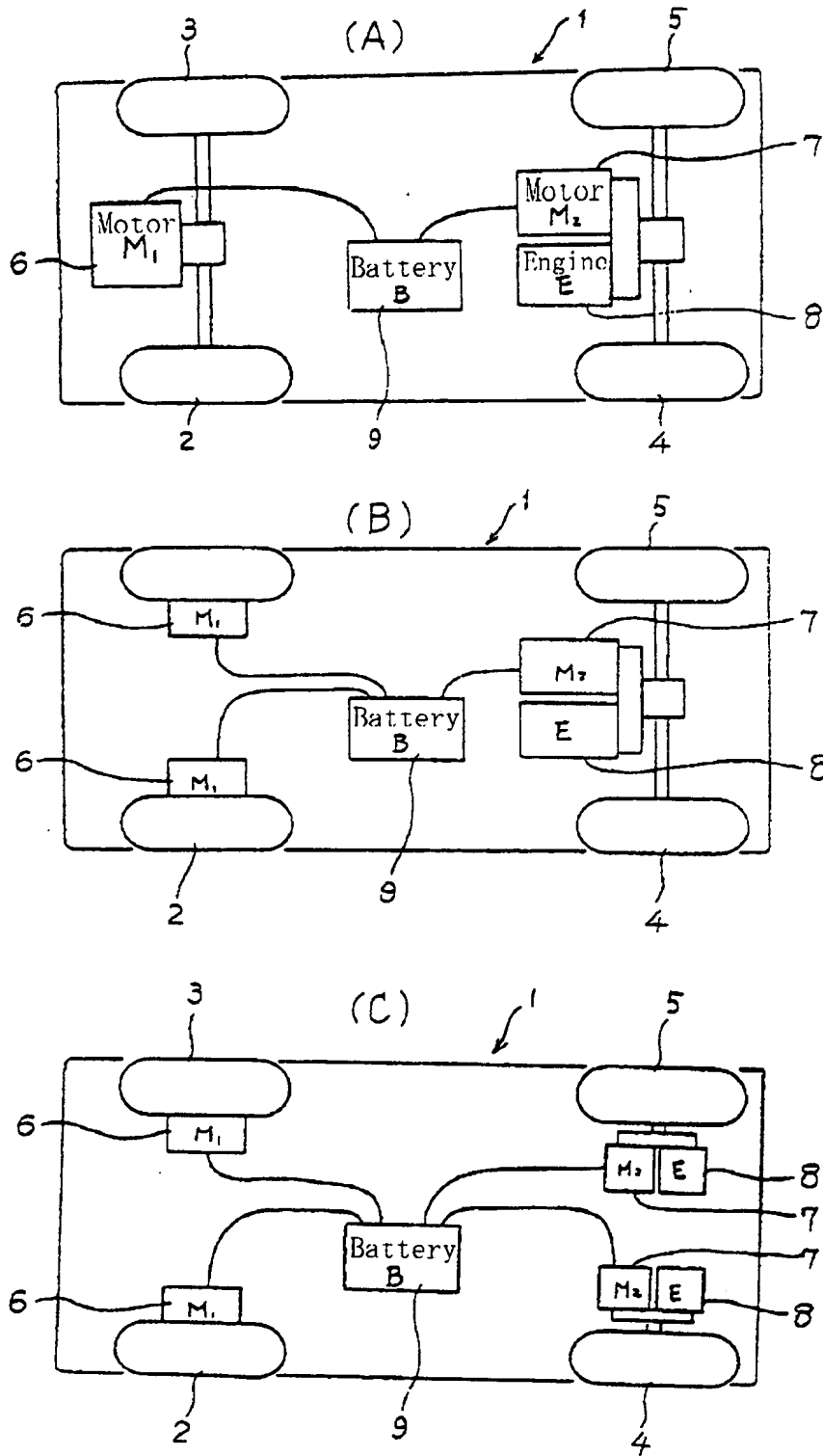

FIG. 2

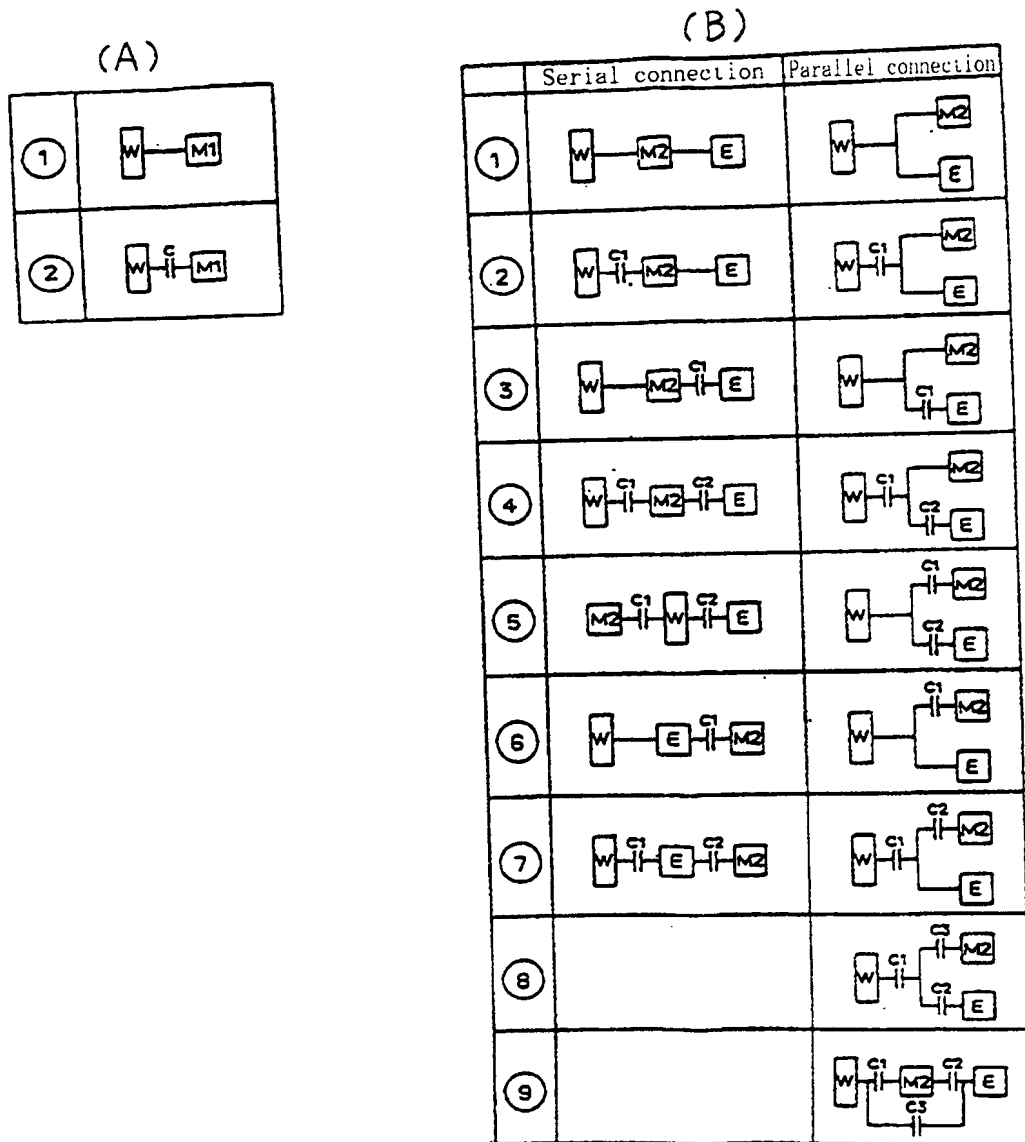

FIG. 3

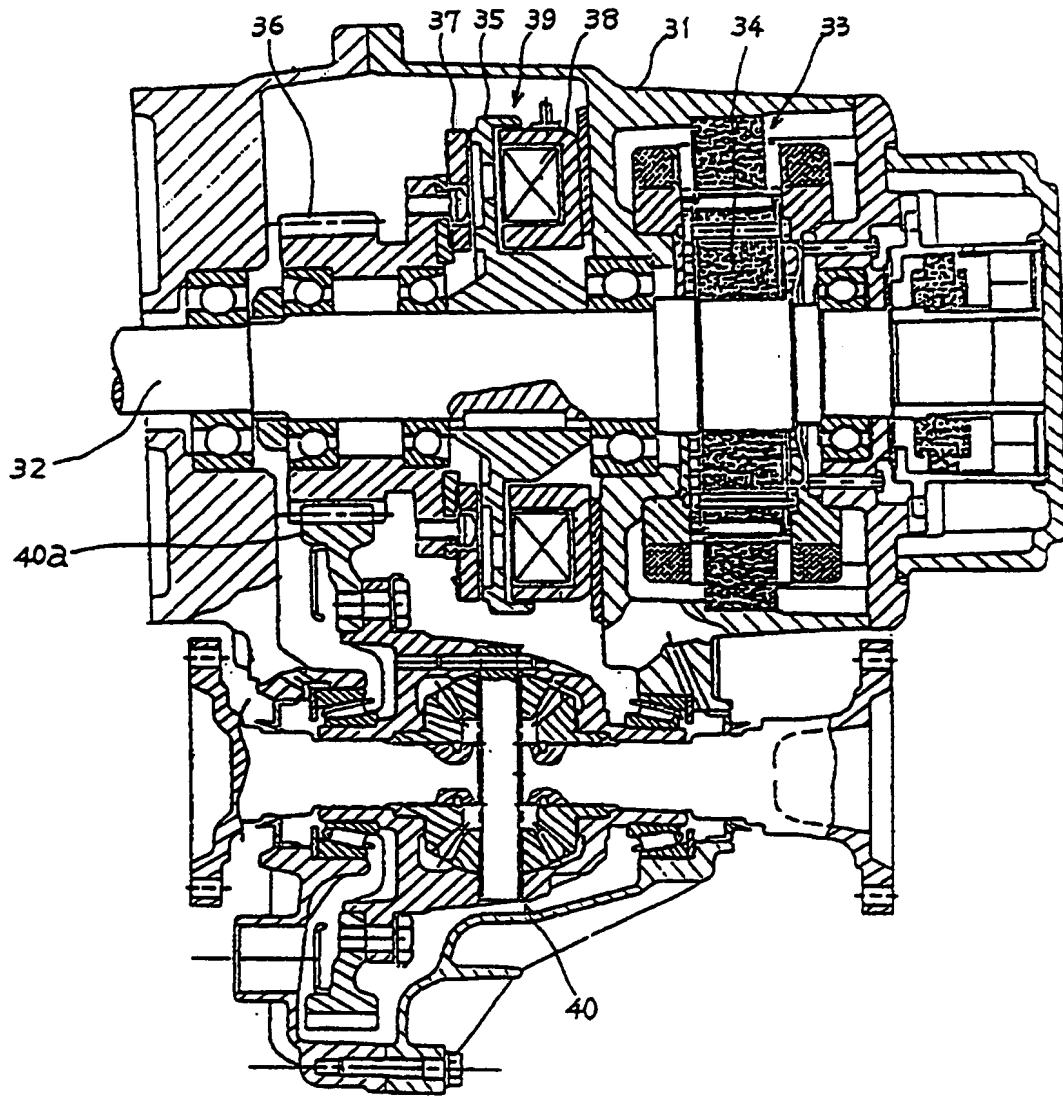

FIG. 4

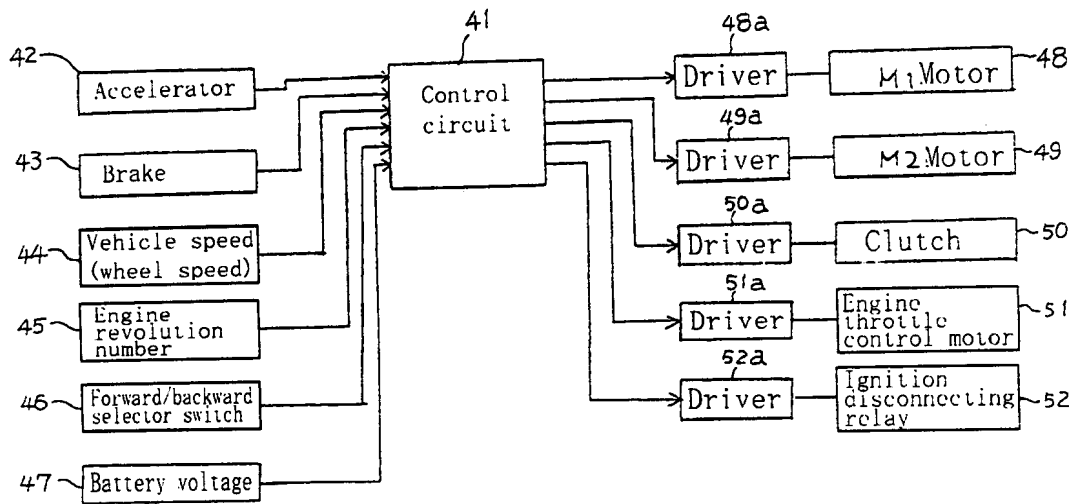
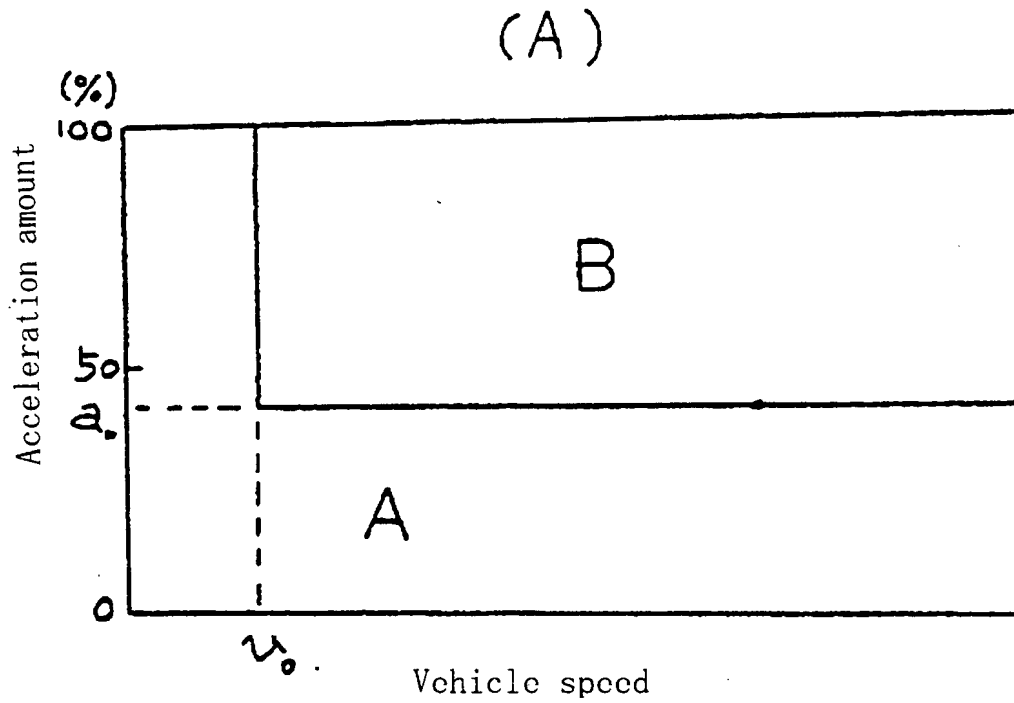

FIG. 5



(B)

Mode Element	A	B	C	D
M <sub>1</sub>	O	O	X	G <sub>B</sub>
E	O	O	O	X
M <sub>2</sub>	G <sub>E</sub>	O	G <sub>E</sub>	G <sub>B</sub>
C	X	O	X	O

O: Operated or engaged  
 X: Non-operated or disengaged  
 GE: Power generation by engine  
 GB: Power generation by regenerative braking

FIG. 6

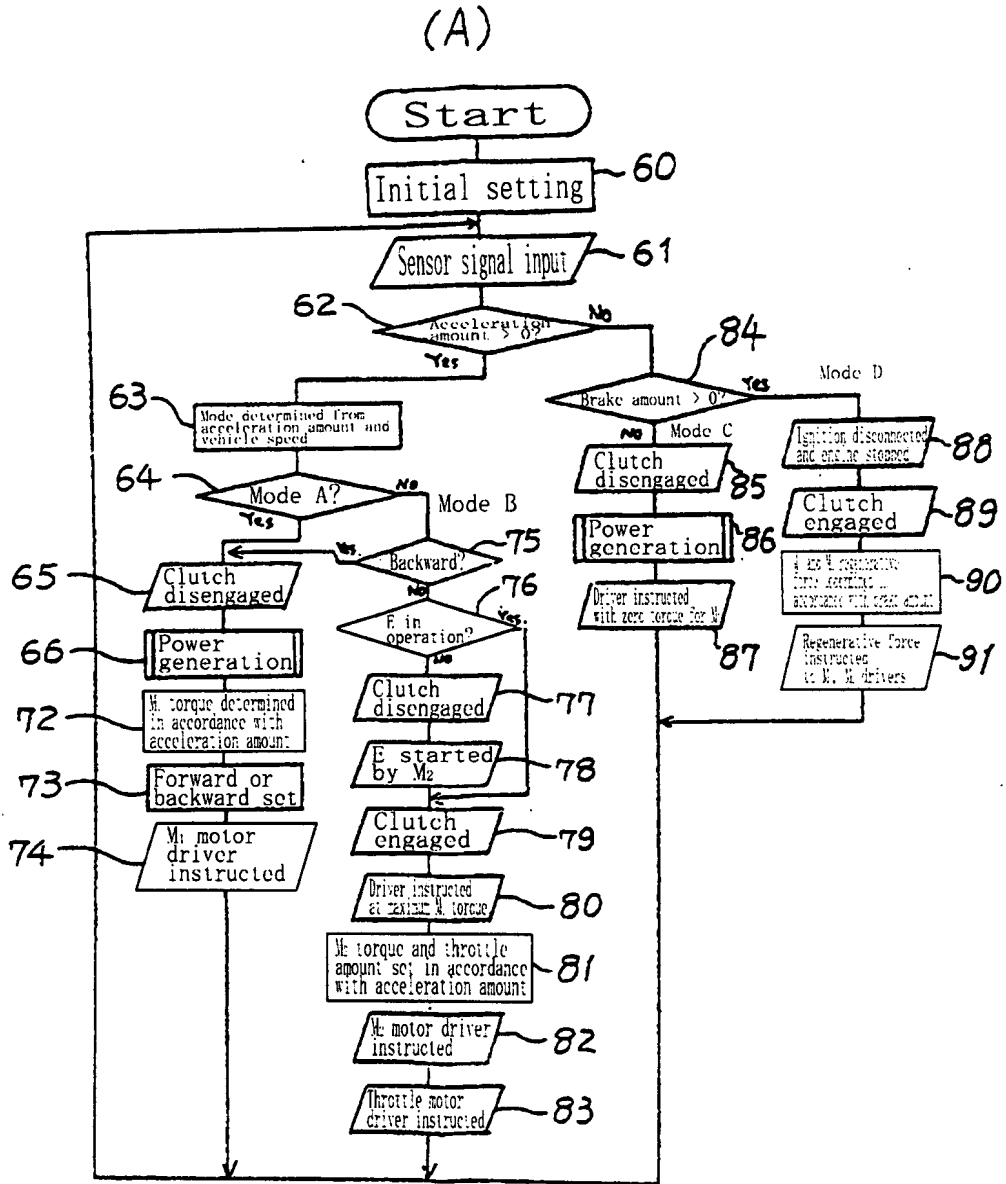
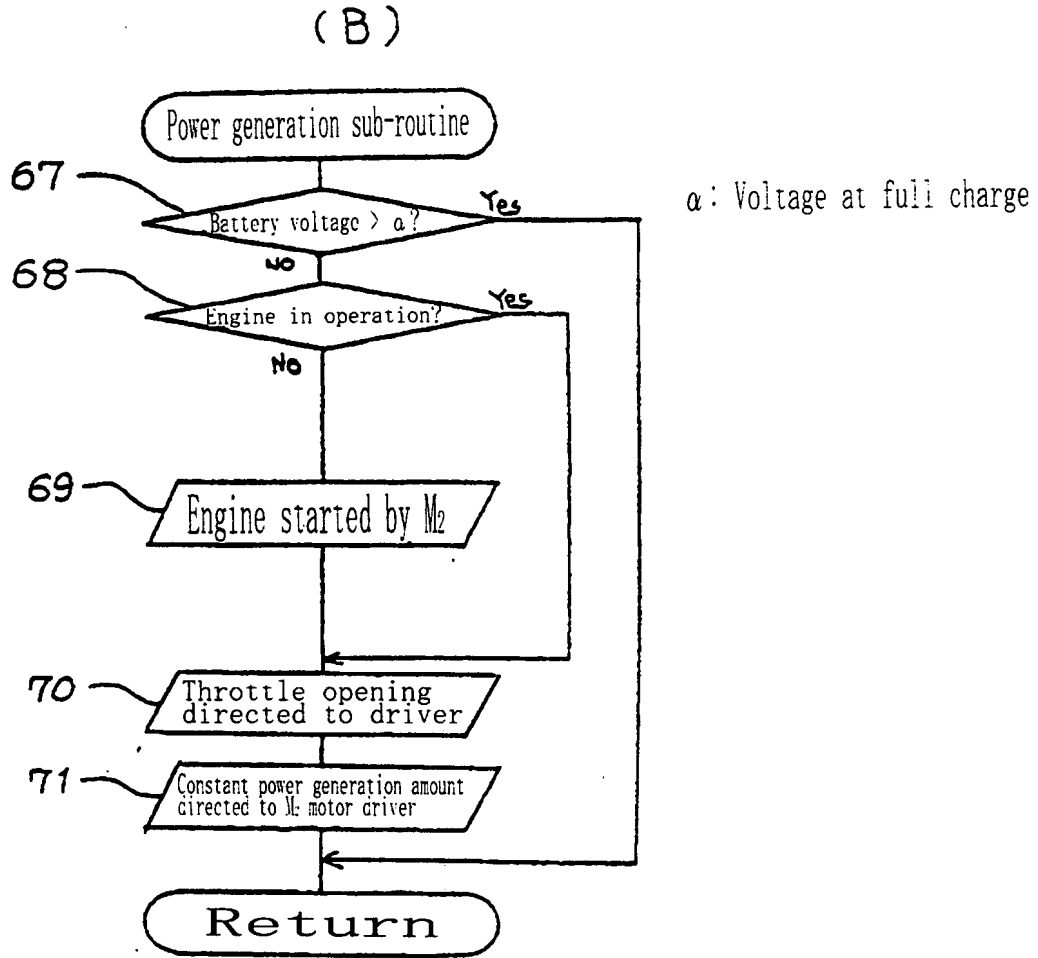

FIG. 6



⑬ 日本国特許庁 (JP)  
⑭ 公開特許公報 (A)

⑮ 特許出願公開  
昭55—127221

① Int. Cl.<sup>3</sup>  
B 60 K 17/04

識別記号

庁内整理番号  
7721—3D

③ 公開 昭和55年(1980)10月1日

発明の数 1  
審査請求 未請求

(全 8 頁)

⑤ 自動車の駆動装置

① 特 願 昭54—34977  
② 出 願 昭54(1979)3月20日  
⑦ 発 明 者 川勝史郎

池田市桃園2丁目1番1号ダイ  
ハツ工業株式会社内  
⑧ 出 願 人 ダイハツ工業株式会社  
池田市ダイハツ町1番1号  
⑨ 代 理 人 弁理士 深見久郎

明 細 書

1、発明の名称

自動車の駆動装置

2、特許請求の範囲

少なくとも、自動車を定速走行駆動可能な出力を有する内燃機関、

電動駆動によつて停止中の前記内燃機関を起動しかつ発電駆動によつて比較的短時間における内燃機関の出力を吸収し得る能力を有する第1の電動発電機、

電動駆動によつて前記自動車を加速あるいは定速走行させかつ発電駆動によつて自動車を減速走行させ、自動車の加減速を含むあらゆる走行状態に耐え得る能力を有し、その出力軸が自動車の駆動輪に関連的に結合される第2の電動発電機、

前記内燃機関の軸出力を検出する第1の検出手段、

前記第2の電動発電機の軸出力を検出する第2の検出手段、

少なくとも、前記内燃機関と前記第1の電動発

(1)

電機とを選択的に連結または切離し、かつ内燃機関と前記第2の電動発電機とを選択的に切離しまたは連結する連結機構、および

前記第1の検出手段出力と前記第2の検出手段出力とに基づいて前記連結機構の連結状態を制御する制御手段を備えた自動車の駆動装置。

3、発明の詳細な説明

この発明は自動車の駆動装置に関し、特にたとえば内燃機関による機械的駆動源と電動機による電氣的駆動源の二系統の駆動源で駆動する自動車(いわゆるハイブリッド車)において、燃費効率の優れた領域において内燃機関を運転駆動させ、それ以外の領域では電動機または電動機と内燃機関の二系統で駆動することにより、燃費効率の優れた、自動車の駆動装置に関するものである。

一般に、内燃機関(エンジン)駆動による自動車は、走行状態と負荷条件との関係によつて、単位燃費(1ℓ)当りに走行可能な距離が異なることが知られている。

第1図はエンジン回転速度とトルクとの関係に

(2)



かける燃費を表わす等燃費率( $g/p \cdot h$ )曲線図の一例を示す。図において、横軸をエンジンの回転速度( $rpm$ ) $\times 10^3$ とし、縦軸を軸トルク( $kg-m$ )とすると、図示の等燃費率曲線から明らかのように、トルクが $6 kg-m \sim 9 kg-m$ の範囲でありかつエンジンの回転速度が $1500 \sim 3500 rpm$ の領域において燃費率の優れていることがわかる。そこで、燃費効率よく自動車を運転するには、低燃費率領域(たとえば $210 \sim 220 g/p \cdot h$ )で常にエンジンを駆動できるようにエンジンの回転速度およびトルクを選んで運転すれば理想的である。

さらに、最近のエネルギー危機から端を発して、燃費効率が優れ、低燃費の自動車が切望されている。また、自動車の増加に伴い、人体に悪影響を与える自動車の排ガスの低減が叫ばれている。このような自動車の排ガスは、第1図に示す等燃費率曲線と相関関係があり、燃費率の優れた領域において運転すると、比較的排ガスの有害成分が少なく、燃費率が悪くなるに従って排ガスの有害成分

(3)

つその出力軸が自動車の駆動軸に連結された第2の電動発電機と、内燃機関の軸出力を検出する手段と、第2の電動発電機の軸出力を検出する検出手段とを設けて、さらに、少なくとも内燃機関と第1の電動機とを選択的に連結または切離しかつ内燃機関と第2の電動発電機とを選択的に切離しまたは連結する連結機構を含んで構成した自動車の駆動装置である。そして、好ましくは、内燃機関の回転数が等燃費率の優れた低速側領域に達するまでは第2の電動発電機を電動機として動かして該第2の電動発電機の駆動力で自動車を走行駆動し、燃費率の優れた領域におけるトルク・回転速度状態において内燃機関と電動発電機の軸を連結させて内燃機関の原動力で走行駆動をさせ、このとき高トルク側領域を越えない程度のみ内燃機関の駆動源から動力を得るとともに、高トルク領域を越える所要トルクを第2の電動発電機から動力を得るように制御する。逆に所要トルクが小さくなった場合は燃費率の優れた領域における低トルク側領域に沿って内燃機関を運転制御し、その

(5)

分も増加する傾向にあることが知られている。

それゆえに、この発明の主たる目的は、内燃機関と電動機による二系統の駆動源で走行する自動車において燃費率の優れた領域においてのみ内燃機関を運転させるように制御し、燃費率の悪い領域では電動機を利用してまたは電動機と内燃機関の両方を利用して自動車を走行駆動させることにより、燃費率が優れて低燃費でありかつ排気ガスによる公害の少ないような、自動車の駆動装置を提供することである。

この発明の上述の目的およびその他の目的と特徴は図面を参照して行なり以下の詳細な説明から一層明らかとなる。

この発明を要約すれば、比較的出力(馬力)の小さなエンジンと、電動機として駆動する場合に停止中の内燃機関を起動させかつ発電機として駆動させる場合に比較的短時間において内燃機関の出力を吸収できる程度の能力を有する第1の電動発電機と、自動車の加減速を含むあらゆる走行状態において自動車を走行駆動可能な出力を有しか

(4)

所要トルクと内燃機関の低トルク側領域運転で得られるトルクとの差のトルクを第2の電動発電機の発電制動力を利用して得るようにしたものである。

第2図はこの発明の一実施例の自動車の駆動系の概略を表わす図解図である。図において、内燃機関(エンジン)21の出力軸211は、連結機構の一例のトランスミッション22を介して第1の電動発電機231と第2の電動発電機232に連結される。このトランスミッション22は、たとえばクラッチ221と222と223を含み、クラッチ221と223とを作動させることによりエンジン21と電動発電機231とを連結し、クラッチ223を切りかつクラッチ221と222とを作動させることによりエンジン21と電動発電機232とを連結し、クラッチ221を切りかつクラッチ223と222とを作動させることにより電動発電機231と232とを連結し、全てのクラッチ221~223を切ることにより電動発電機232のみを独立して駆動させるように切

(6)

替えるものであつて、後述の制御手段27に含まれるトランスミッション制御部273によつて選択的に連結または切離し制御が行なわれる。このようなクラッチ221~223としては、たとえば電磁クラッチやシンクロ形クラッチなどが利用される。

前記電動発電機231は、クラッチ221, 223を作動させた状態において、電動機として作動させることによつてエンジン21の停止中に該エンジン21を瞬時起動させたり、発電機として駆動することによつてエンジン21の出力(トルク・回転数)を発電制御によつて吸収するものであつて、比較的短時間(たとえば3分)定格の極めて小型かつ安価のものが用いられる。

前記第2の電動発電機232は、自動車のあらゆる加減速走行状態でも駆動し得る程度の比較的大出力を有し、電動機として作動させた場合にはその電動力のみまたはその電動力とエンジン21の原動力との和の出力で自動車を走行駆動し、発電機として作動させた場合にはエンジン21を予

(7)

ミッション制御部273およびエンジン制御部274を制御する演算制御部(例えばマイクロプロセッサ)271を含み、その出力でエンジン21, トランスミッション22, 電動発電機231および232を制御するものである。また、電動発電機制御部271に関連して、蓄電池28が設けられる。この蓄電池28は、電動発電機231, 232が電動機として駆動するとき、その直流電力を該電動発電機に供給し、電動発電機231, 232が発電機として駆動されるとき、発電された出力で充電されるものである。

なお、前記トランスミッション22はその他の構造のものであつても同様にエンジン21と電動発電機231と電動発電機232とを切替または連結することかできる。

第3A図は連結機構の他の例を示すトランスミッション32の図解図であり、第3B図はトランスミッション32の機構図である。図において、他の実施例のトランスミッション32は、エンジン21と電動発電機231を選択的に連結または

(9)

め定める燃費率で回転駆動させたときの低トルク側よりも小さなトルク領域で走行するとき、又は坂を下るとき等負のトルクが必要なときに発電制御として吸収するように動くものである。この電動発電機232の出力軸233は、従来のエンジン駆動のみによる自動車とはほぼ同様に構成されるトランスミッション24を介して自動車の駆動輪25に連結される。

前記エンジン21の出力軸211には、該出力軸211のトルク・回転数を検出するためのトルク・回転数検出器(第1の検出手段)261が設けられる。前記電動発電機232の軸出力には、トルク・回転数検出器(第2の検出手段)262が関連的に設けられる。このトルク・回転数検出器261, 262の検出出力は、制御手段27に与えられる。

前記制御手段27は、アクセルペダル270およびブレーキペダル275の踏込み量に相関する信号とトルク・回転数検出器261, 262の入力に基づいて電動発電機制御部271とトランス

(8)

切離すためのクラッチ321、およびエンジン21と電動発電機232を選択的に連結または切離すためのクラッチ322、ならびに電動発電機231と232とを連結するためのクラッチ323を含む。なお、トランスミッション32の構造は、一般に知られているシンクロ型クラッチの構造を参照すれば容易に理解できるため、単に図解のみを示し、その詳細な説明を省略する。

第4図はこの発明の動作を説明するための動作特性の図解図であり、特にたとえば第4図(a)は定地走行モード例を示し、第4図(b)図は第4図(a)の走行モードにおけるトルクと回転数との関係を図解的に示した図である。

次に、第1図ないし第4図を参照して第4(a)に示す定地走行に沿った動作を説明する。

前記エンジン21の出力は、前記等燃費率曲線特性における比較的優れた燃費率の領域(たとえば $220 \text{ g/p}\cdot\text{h}$ 以下)に選り、その等燃費率曲線領域をエンジン21の許容運転領域と定める。従つて、エンジン21は、許容運転領域において自

00

動車を走行駆動するのに要するトルクおよびエンジン回転速度となるような比較的 low 出力のものが用いられる。

まず、自動車の駐車状態においては、トルク・回転数検出器 261, 262 のいずれの出力もなくかつアクセルペダル 270 の踏み込み状態でもないため、演算制御部 271 は電動発電機制御部 272 に信号を与えず、電動発電機 231, 232 への電源供給を遮断した状態であるとともに、たとえばキャブレターを全閉し、さらにトランスミッション制御部 273 にも信号を与えずにクラッチ 221 および 222 を作動（すなわちノーマルオン）させている。このクラッチ 221, 222 の作動により、エンジン 21 と電動発電機 232 さらには駆動系 24, 25 とが連結された状態になると、いわゆるエンジンブレーキ状態となり、自動車を斜面に停止させた状態において駆動輪 25 が不所望に回転しようとしても、エンジンブレーキによつて自動車の不所望な走行を防止できる利点がある。

011

電動発電機 232 の回転数はエンジン許容運転領域における下限の速度  $N_a$  に達するが、このときのトルクが高トルク領域以上であるため、依然として電動発電機 232 の電動力による走行状態が続く。このとき、必要に応じて、クラッチ 222 と 223 をオンにして、電動発電機 231 と 232 を連結し、ともに電動機として回転駆動させて加速させるようにしてもよい。

前述のごとく電動発電機 232 の電動力によつて自動車を加速走行させている場合において、出力軸 233 の回転速度がエンジン許容運転領域における下限回転数  $N_a$  以上になると、演算制御部 271 はトランスミッション制御部 273 を介してクラッチ 221, 223 をオンさせる。さらに、演算制御部 271 は電動発電機制御部 272 を介して電動発電機 231 を電動機として作動させて、電動発電機 231 の電動力をクラッチ 223 および 221 を介してエンジン 21 に伝達させる。従つて、電動発電機 231 の回転力でエンジン 21 が瞬時に起動される。このとき、当然エンジン制

012

次に、t0 から t1 の時間に加速走行する場合、運転者は当然それに先立つて、図示しないがキースイッチの始動切替え操作をする。その操作に応じて、演算制御部 271 はトランスミッション制御部 273 に信号を与えて全てのクラッチ 221 ~ 223 を切離させる（すなわちオフさせる）。そして、運転者がアクセルペダル 270 を徐々に踏み込むと、演算制御部 271 は電動発電機制御部 272 に信号を与えて蓄電池 28 の出力電圧を電動発電機 232 に供給させて、該電動発電機 232 を電動機として回転駆動させる。この電動発電機 232 の電動力がトランスミッション 24 を介して自動車の駆動輪 25 に伝達されるため、自動車は加速走行する。このとき、電動発電機 232 の出力軸 233 に加わる出力がトルク・回転数検出器 262 で検出され、演算制御部 271 に与えられる。この状態において、自動車の加速走行に要するトルクが第 4 図(b)の t0 ~ t1 におけるトルク特性線で示される。そして、自動車の走行開始時から定速運転に入る直前の t2 時刻において、

013

制御部 274 にも所定の信号が与えられる。エンジン 21 が起動すると、その出力軸 211 のトルク・回転数がトルク・回転数検出器 261 で検出されて演算制御部 271 に与えられる。応じて、演算制御部 271 はエンジン制御部 274 を介して、エンジンを加速させるとともに電動発電機制御部 272 を介して電動発電機 231 を発電機に切替えてエンジン 21 の負荷を吸収させる。こうしてエンジン 21 の回転数が電動発電機 232 の回転数に追従するように制御されかつエンジン 21 のトルクがトルク・回転数検出器 262 で検出される負荷の必要とするトルクに追従される。そして、負荷の所要トルクがエンジン許容運転領域の高トルク領域を越えていれば、演算制御部 271 はエンジン制御部 274 と電動発電機制御部 272 を介してエンジン 21 および電動発電機 231 を制御して、エンジン 21 の出力をエンジン許容領域における高トルク側に沿つて制御する。

ところで、電動発電機 232 の電動力によつて、自動車が定速運転走行速度  $V_1$  に達したとき (t1)、

014

運転者がアクセルペダル270操作して加速走行から定速走行へ移行させると、自動車の必要とするトルクが低下する。従つて、エンジン21の回転数およびトルクが許容運転領域の範囲内となる。この状態がトルク回転数検出手段261、262の出力によつて検出されると、演算制御部271はトランスミッション制御部273を介してクラッチ223をオフさせるとともにクラッチ221、222をオンさせ、かつ電動発電機制御部272に信号を与えて電動発電機232への電源供給を停止させてその駆動を停止させる。これによつて、以後エンジン21の原動力がクラッチ221、222、電動発電機232の回転軸233およびトランスミッション24を介して駆動輪25に伝達され、エンジン21のみでアクセルペダル270からの信号を演算制御部271で演算し、その出力によつて制御されるエンジン制御部274によつて、定速走行駆動される。このとき、電動発電機232は単にフライホイールとして動く。

なお、前述のごとくエンジン21の原動力のみ

04

ン制御部273を介してクラッチ221、222をオフさせかつエンジン制御部274を介しエンジン21をアイドル状態にする。なお、このときエンジン21を停止させてもよい。そして、演算制御部271は電動発電機制御部272に信号を与えて電動発電機232を高速回転させ、必要とするトルクまで加速させる。このとき、電動発電機232の最大トルクで不足する場合は、クラッチ223と222をオンさせて電動発電機231と電動発電機232とを連結することにより、不足したトルク分を電動発電機231の電動力によつて補つてもよい。

続いて、時間t2において、自動車の走行速度を相対的に高速度V2から減速する場合は、アクセルペダル270の踏み込みを戻す操作に応じて行なわれる。この場合はアクセルペダル270の踏み込み減速に比して回転軸233の回転数が高すぎることになる。また、ブレーキペダル275が同時に操作されることもあるが、いずれの場合も演算制御部271の命令によりトランスミッション制

07

で走行している状態において、坂道走行等により、負荷の必要とするトルクがエンジン21を高トルク領域で回転駆動させても不足する場合は、以下のごとく制御される。すなわち、トルク・回転数検出器261と262の出力に基づいて、演算制御部271は電動発電機制御部272に信号を与えて電動発電機232を電動機として回転駆動させて不足分のトルクを補わせる。

次に、t1~t1'時間における定速走行状態後さらに速度V2まで加速したい場合には、運転者がさらにアクセルペダル270を踏み込む。このため、負荷の必要とするトルクが増大し、エンジン許容運転領域の高トルク領域を越えると、演算制御部271は電動発電機制御部272に信号を与えて電動発電機232を電動機として回転駆動させて、エンジンによる高トルク領域を越えるトルク分だけ電動発電機232の電動力で補わせる。そして、さらに出力軸211の回転数がエンジン許容運転領域における上限回転数Nbを越えると、それに応じて演算制御部271はトランスミッ

08

ン制御部273を介してクラッチ221と222、223をOFFにするか、又は必要に応じてクラッチ221のみをOFFにし、かつ電動発電機制御部272を介して電動発電機232または必要に応じて電動発電機231を発電機として駆動し、必要減速作用をおさしめる。従つて、この場合結果的にトルク・回転数検出器262の出力は負となる。この場合、エンジン21は関与しない。図示していないが、もし仮に負荷の要求トルクが正でかつエンジン許容運転領域より低い場合は演算制御部271はエンジン制御部に命令を与えエンジン21のトルクがエンジン許容運転領域における低トルク域となるように、エンジンを低トルク領域で運転させると同時に、トルク・回転数検出器261の出力とトルク・回転数検出器262の出力の差に基づくトルクを吸収するために、電動発電機制御部272に信号を与えて電動発電機232を発電機として作動させる。これによつて、電動発電機232は、発電制動し、負荷の必要とするトルクとエンジン21を許容運転領域におけ

09

る低トルク領域で運転した場合のトルクとの差を吸収し、その発電電力を電動発電機制御部272を介して蓄電池28に与えて蓄電池28を充電させる。このように、負荷の必要とするトルクとエンジン21の許容運転領域における低トルク領域での運転におけるトルクとの差に基づいて発電された電力で蓄電池28を充電しているため、エネルギーのロス無くし、エネルギーの効率的利用を図れる。この場合においても、差のトルクが電動発電機232を発電機として動かした場合に吸収し得るトルクよりも大きければ、クラッチ223をオンさせることにより、電動発電機231を発電機として動かして該電動発電機231の発電電力でトルクを吸収させるようにしてもよい。

そして、自動車の走行速度がエンジン許容運転領域における加減速度 $V_0$ 以下になると、全てのクラッチを切離してエンジンをアイドル状態とし、燃料消費を最低限に保ちつつ、電動発電機232を発電機として作動させることによつて発電駆動させて、自動車の惰速走行によるエネルギ

09

ーで発電した電力を蓄電池28に充電電流として供給して回収し、蓄積させる。

上述のごとく、この実施例によれば、エンジンの運転は燃費率の優れたエンジン許容運転領域でのみ行なうように制御し、駆動輪に連結された軸233の回転数がエンジン許容運転領域の下限値以下であれば電動発電機232を電動機として動かした駆動力のみで運転走行し、エンジン許容運転領域の高トルク領域を越えた場合においてはエンジン駆動と電動機駆動とを併用し、負荷が必要とするトルクがエンジン許容運転領域の低トルク域以下の場合は電動発電機232を発電機として作動させて発電制動によつて生じる発電電力で蓄電池を充電するように制御しているため、燃費率が極めて優れ、しかも排気ガスを大幅に低減できる利点がある。また、電動発電機232の発電状態においては、発電電力で蓄電池を充電しているため、トルクの吸収に合わせてエネルギーを効率的に回収して蓄積でき、蓄電池28を夜間等に充電するための電力消費も低減でき、総合的燃費を

10

大幅に安くできる利点がある。また、電動発電機231は比較的短時間定格のもので良いため、極めて小さくかつ安価なものを利用でき、自動車の車体重量の大幅な増加を伴うこともない。

以上のよう、この発明によれば、燃費効率が優れ、比較的安価であつて、損失となるべきエネルギーを利用して蓄電池を充電することができ、低公害となるようか、自動車の駆動装荷が得られる。

なお、前述の説明では、エンジンの出力と電動発電機の出力を検出するために、トルク・回転数検出手段を用いて検出し、回転数を基準とする制御方式の場合について説明したが、これに限ることなくトルクを基準とする制御方式であつても、この発明の技術思想を適用できることは言うまでもない。

#### 4. 図面の簡単な説明

第1図は燃費率曲線の特性図である。第2図はこの発明の一実施例の概略を要する図解図である。第3A図はトランスミッションの他の例を示

11

す図解図であり、第3B図はその機構図である。第4図はこの発明の動作を説明するための動作特性の図解図である。

図において、21はエンジン(内燃機関)、22はトランスミッション(連結機構)、231は第1の電動発電機、232は第2の電動発電機、261はトルク・回転数検出器(第1の検出手段)、262はトルク・回転数検出器(第2の検出手段)、27は制御手段を示す。

特許出願人 ダイハツ工業株式会社  
代理人 弁理士 深見久郎

12

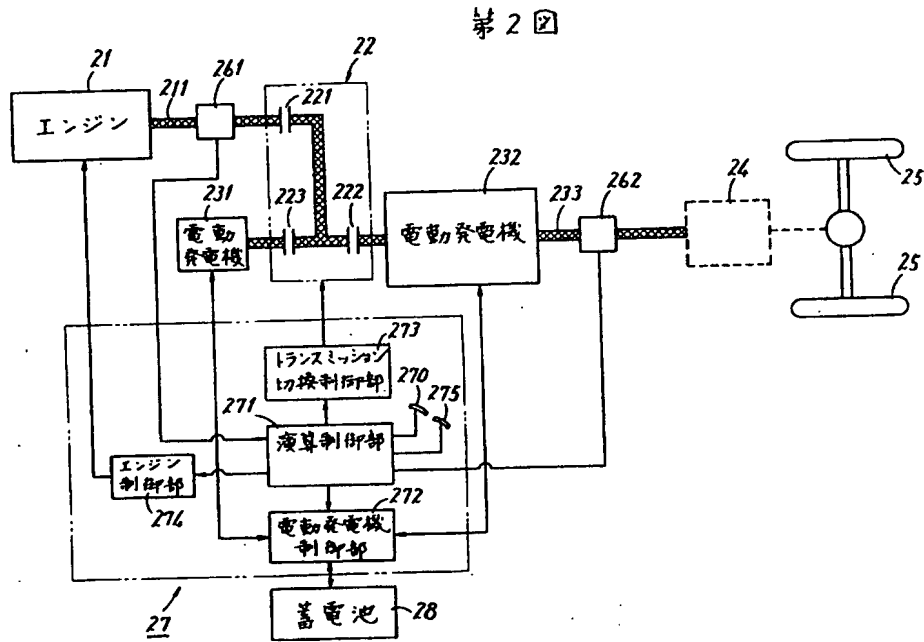
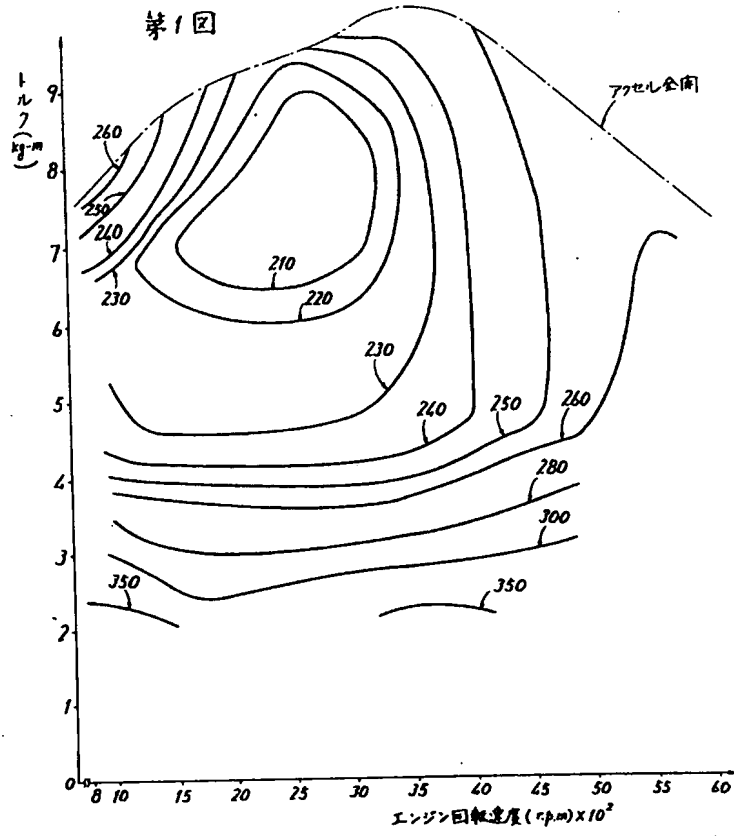

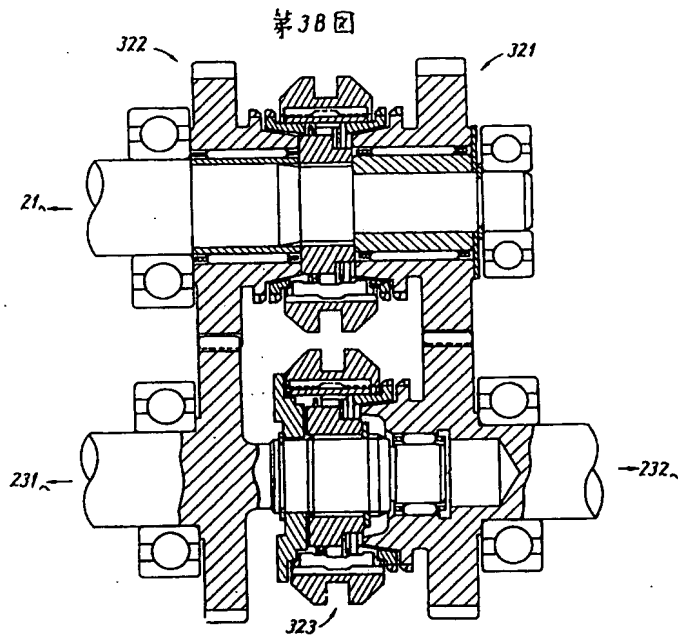
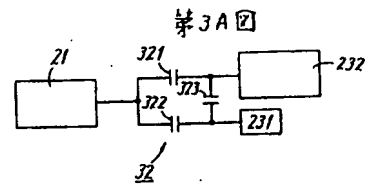

第4図

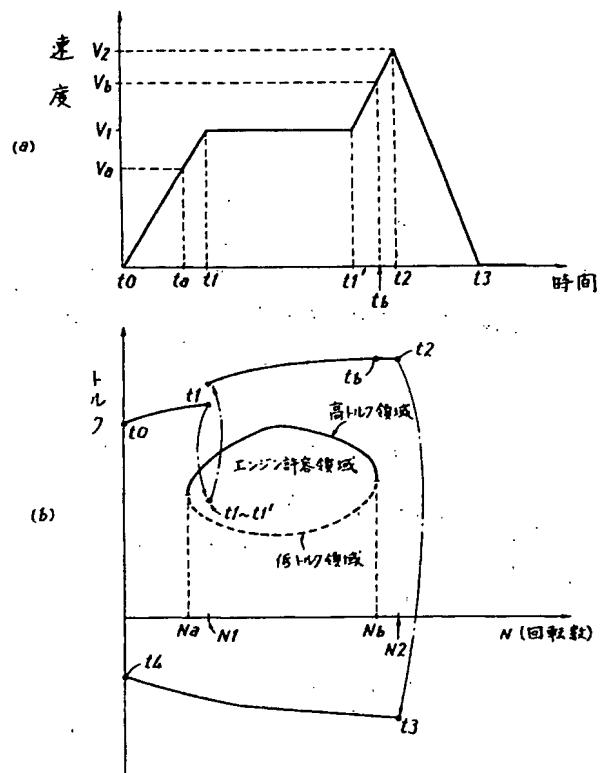

### 3. DETAILED DESCRIPTION OF THE INVENTION

The present invention relates to a driving device for a vehicle. In particular, the present invention relates to a vehicle driving device, whereby a vehicle (specifically, a so-called hybrid vehicle) that runs, for example, by a mechanical drive source using an internal combustion engine and an electrical drive source using motors drives an internal combustion engine within a running range where mileage is high, and drives the motors and/or the internal combustion engine in other running ranges, thereby increasing fuel efficiency.

Generally, it is known that a vehicle that runs by an internal combustion engine varies in propulsion distance per unit quantity of fuel (1 liter) according to the relation between the running state and load conditions.

FIG. 1 is an example of a diagram of curves joining points where mileages (g/psh) are equal, in relation to engine revolutions and torque. The horizontal axis indicates the rotational speed (rpm)  $\times 10^2$  of the engine and the vertical axis indicates shaft torque (kg-m). As is apparent from the curves, mileage is high if the torque is in the range of 6kg-m to 9kg-m and the rotational speed of the engine is in the range of 1500 to 3500 rpm. It is ideal to run the vehicle fuel efficiently by choosing a rotational speed and engine torque such that the engine can always be driven within a low fuel cost range (e.g., 210 to 220g/psh).

Further, the recent energy crisis has given rise to a great demand for more fuel-efficient, lower fuel cost vehicles. Also, an increase in the number of vehicles overall, has given rise to a demand for reductions in harmful exhaust gases. Emission of such exhaust gases from vehicles correlates with the curves joining points of equal mileage. If a vehicle is driven within the range where fuel efficiency is high, harmful components in the exhaust gases relatively decrease. By contrast, as fuel efficiency becomes lower, harmful components in the exhaust gases tend to increase.

Accordingly, it is a principal object of the invention to provide a vehicle driving device that makes it possible to realize a more fuel efficient, lower fuel cost vehicle that produces less environmentally pollutive exhaust gases by driving the vehicle, which is run by two driving sources involving an internal combustion engine and motors, such that the engine runs alone only in a high mileage range while motors



and/or engine may run in low mileage ranges.

The above and other objects and features of the present invention will be better understood by reading the following detailed description in connection with the accompanying drawings.

The present invention is summarized as follows. A vehicle driving device according to the present invention includes: a relatively small output (in terms of horse power) engine; a first motor generator capable of starting the engine from standstill when functioning as a motor and capable of absorbing the output of the engine within a relatively short time when functioning as a generator; a second motor generator that generates an output capable of driving the vehicle in any running state including acceleration and deceleration, and that has an output shaft connected to the drive wheels; a means for detecting the shaft output of the engine; a means for detecting the shaft output of the second motor generator; and, further, a connecting mechanism for at least selectively connecting the engine and the first motor generator or disconnecting them from each other and selectively connecting the engine and the second motor generator or disconnecting them from each other. Preferably, until rpm of the engine reaches the low speed ranges in which fuel efficiency becomes high, the second motor generator functions as a motor, and the vehicle is driven with the electromotive power of the second power generator. When the torque and the rotational speed of the engine reaches the range of high fuel efficiency, the shafts of the engine and motor generators are coupled to drive the vehicle with the motive power of the engine. At this time, power is obtained from the drive source of the engine so as not to exceed the high torque range, and the required torque exceeding the high torque range is obtained from the second motor generator. On the other hand, when the required torque lessens, the engine is run according to the more fuel efficient low torque range, and the torque resulting from the difference between the required torque and the torque produced by running the engine within the low torque range is obtained using the dynamic braking force of the second motor generator.

FIG. 2 is a diagram schematically showing the driving system of a vehicle according to an embodiment of the present invention. In FIG. 2, an output shaft 211 provided for an internal combustion engine (hereinafter simply referred to as

"engine") 21 is coupled to first and second motor generators 231 and 232 via a transmission 22, which is an example of a connecting mechanism. The transmission 22 includes, for example, clutches 221, 222 and 223, and switches them as described below. Engaging the clutches 221 and 223 couples the engine 21 and the motor generator 231. Disengaging the clutch 223 while engaging the clutches 221 and 222 couples the engine 21 and the motor generator 232. Disengaging the clutch 221 while engaging the clutches 223 and 222 couples motor generators 231 and 232. Disengaging all the clutches 221 to 223 drives only the motor generator 232 independently. A transmission control unit 273 incorporated in a control means 27 (described below) exerts selective control of engagement or disengagement. Examples of such clutches 221 to 223 include electromagnetic clutches and synchronous type clutches.

While the clutches 221 and 223 are engaged, the motor generator 231 operates as a motor, thereby causing the engine 21 to instantaneously start from standstill, or operates as a generator, thereby absorbing the output of the engine 21 (torque, rpm) by dynamic braking. The one that is relatively short time (e.g., three minutes) rated, extremely small, and inexpensive is used.

The second motor generator 232 has a relatively large output sufficient to drive the vehicle at any speed regardless of whether the vehicle is accelerating or decelerating. When operating as a motor, the second motor generator 232 runs the vehicle on the output of only its electromotive power or the output of a combination of this electromotive power and the motive power of the engine 21. When operating as a generator, on the other hand, the second motor generator 232 absorbs torque by dynamic braking, as in the case where the vehicle is running with torque less than that produced by rotating the engine 21 with a predetermined fuel efficiency, or in the case where the vehicle is running down a sloping road and therefore requiring negative torque. The output shaft 233 of the motor generator 232 is coupled to the drive wheels 25 of the vehicle via another transmission 24 that has a configuration similar to that of the transmission of a conventional vehicle driven only by an engine.

Disposed on the output shaft 211 of the engine 21 is a detector (first detecting means) 261 for detecting the torque and rpm of the output shaft 211. In relation to this, disposed

on the output shaft of the motor generator 232 is another detector (second detecting means) 262 for detecting the torque and rpm of the output shaft. The detection outputs of the detectors 261 and 262 are supplied to the control means 27.

The control means 27 includes an arithmetic and control unit (e.g., microprocessor) 271 that controls a motor-generator control unit 272, transmission control unit 273, and engine control unit 274 based on the inputs from the detectors 261 and 262 and a signal indicating the correlation between the degrees of depression of an accelerator pedal 270 and a brake pedal 275. Based on the output of the arithmetic and control unit 271, the control means 27 controls the engine 21, transmission 22, and motor generators 231 and 232. Additionally, in association with the motor-generator control unit 272, a battery 28 is provided. When the motor generators 231 and 232 are driven as motors, the battery 28 supplies direct current to the motor generators. Conversely when the motor generators 231 and 232 are driven as generators, the battery is charged with the output of generated electrical energy.

Similarly, the transmission 22 with a configuration different from that described above is also able to switch between the engine 21 and the motors 231 and 232 or connect them.

FIG. 3A is a diagram of a transmission 32, which is another example of the connecting mechanism. FIG. 3B is a diagram of the mechanism of the transmission 32. In FIGS. 3A and 3B, the transmission 32 according to another embodiment includes: a clutch 321 for selectively connecting the engine 21 and the motor generator 231 or disconnecting them from each other; a clutch 322 for selectively connecting the engine 21 and the motor generator 232 or disconnecting them from each other; and a clutch 323 for connecting the motor generators 231 and 232. Since the structure of the transmission 32 can be easily understood by referring to the structure of a generally known synchronous type clutch, only the diagram is shown and the description thereof is omitted.

FIG. 4 is a diagram illustrating the motion characteristics of the present invention, in which FIG. 4(a) is a diagram illustrating an example of a fixed ground running mode and FIG. 4(b) is a diagram representing the relation between the torque and rpm in the running mode shown in FIG. 4(a).

Next, referring to FIGS. 1 and 4, the motion occurring in the fixed ground running mode shown in FIG. 4(a) will be described.

The output of the engine 21 is set so as to satisfy the range wherein the vehicle travels at a relatively high mileage (e.g., 220g/psh or less) in terms of the characteristics of the above-mentioned curves joining points of equal mileage. The range determined by the curve indicating relatively high mileage is assigned as a permissible running range for the engine 21. Accordingly, an engine 21 is used that has a relatively low output with torque and rpm sufficient to run the vehicle within the permissible running range.

First, while the vehicle is parked, there is no output from the detectors 261 and 262, which detect torque and rpm, and there is no depression of the accelerator pedal 270, either. Therefore, the arithmetic and control unit 271 gives no signals to the motor generator control unit 272, and the supply of power to the motor generators 231 and 232 is stopped. In addition, for example, while a carburetor is fully closed and no signal is supplied to the transmission control unit 273, the clutches 221 and 222 are in operation (i.e., a normal-on state). When engaging the clutches 221 and 222 links the engine 21, the motor generator 232, and then, the driving systems 24 and 25, the vehicle is brought into a so-called engine brake state. Accordingly, this provides an advantage such that even if the drive wheels 25 of the vehicle are mistakenly driven while it is stopped on a slope, the engine brake prevents the vehicle from running.

Next, when the vehicle accelerates during time  $t_0$  to time  $t_1$ , a driver operates a key switch (not shown) prior to the acceleration. In response to the operation, the arithmetic and control unit 271 gives a signal to the transmission control unit 273, thereby disengaging all the clutches 221 to 223 (i.e., an off-state). When the driver then gradually depresses the accelerator pedal 270, the arithmetic and control unit 271 gives a signal to the motor-generator control unit 272, thereby supplying the output voltage of the battery 28 to the motor generator 232 and consequently rotating the motor generator 232 as a motor. Since the electromotive power of the motor generator 232 is transmitted to the drive wheels 25 of the vehicle via the transmission 24, the vehicle accelerates. At this time, output exerted to the output shaft 233 of the motor

generator 232 is detected by the detector 262, which detects torque and rpm, and the result is supplied to the arithmetic and control unit 271. A torque characteristic line from  $t_0$  to  $t_1$ , shown in FIG. 4(b), indicates the torque required for the vehicle to accelerate in this state. Next, at time  $t_a$  immediately before a constant vehicle running speed is reached from the start of its running, the rpm of the motor generator 232 reaches the lower limit speed ( $N_a$ ) of the permissible running range of the engine. However, the torque at this time is within or beyond the high torque range and therefore the vehicle continues to run on electromotive power produced by the motor generator 232. In this case, if necessary, the clutches 222 and 223 may be engaged to couple the motor generators 231 and 232 such that the motor generators 231 and 232 both rotate as motors to accelerate the vehicle.

When the rotational speed of the output shaft 233 becomes equal to or higher than the lower limit number  $N_a$  of revolutions in the permissible running range of the engine while the vehicle is accelerated by the electromotive power of the motor generator 232 as described above, the arithmetic and control unit 271 engages the clutches 221 and 223 via the transmission control unit 273. Further, via the motor generator control unit 272, the arithmetic and control unit 271 operates the motor generator 231 as a motor, thereby supplying the electromotive power of the motor generator 231 to the engine 21 via the clutches 223 and 221. Accordingly, the engine 21 is instantaneously started by the rotating force of the motor generator 231. In this case, as a matter of course, a specific signal is also applied to the engine control unit 274. When the engine 21 starts, the torque and rpm of the output shaft 211 are detected by the detector 261 and the results are supplied to the arithmetic and control unit 271. In response to this, the arithmetic and control unit 271 accelerates the engine via the engine control unit 274, and also switches the motor generator 231 to generator via the motor-generator control unit 272, thereby causing the generator to absorb the load of the engine 21. Thus, control is exerted such that the rpm of the engine 21 follows the rpm of the motor generator 232 and that the torque of the engine 21 follows the torque required by the load detected by the detector 262 (which detects torque and rpm). If the required torque of the load exceeds the high torque range of the permissible running range

of the engine, the arithmetic and control unit 271 controls the engine 21 and motor generator 231 via the engine control unit 274 and motor generator control unit 272, thereby controlling the output of the engine 21 according to the high torque values of the permissible running range of the engine.

When the vehicle reaches a constant running speed  $V_1$  (at  $t_1$ ) by the electromotive power of the motor generator 232, and the driver operates the accelerator pedal 270 in order to switch from acceleration to constant running, torque required by the vehicle decreases. Consequently, the rpm and torque of the engine 21 fall within the permissible running range. Upon detection of this state by the detecting means 261 and 262, which detect torque and rpm, the arithmetic and control unit 271 disengages the clutch 223 via the transmission control unit 273, engages the clutches 221 and 222, and gives a signal to the motor-generator control unit 272, thereby stopping the supply of power to the motor generator 232 in order to stop driving the motor generator 232. Thereafter, the motive power of the engine 21 is supplied to the drive wheels 25 via the clutches 221 and 222, the rotation shaft 233 of the motor generator 232, and the transmission 24, and then a signal from the accelerator pedal 270 is calculated by the arithmetic and control unit 271. Consequently, the engine control unit 274 controlled by the output runs the vehicle at a constant speed only by the engine 21. At this time, the motor generator 232 functions simply as a flywheel.

If torque required by a load is insufficient despite the engine 21 rotating in a high torque range, as in the case where the vehicle is running on a slope only by the motive power of the engine 21 as described above, control is exerted as described below. That is, based on the outputs of the detectors 261 and 262 that detect torque and rpm, the arithmetic and control unit 271 gives a signal to the motor-generator control unit 272, thereby rotating the motor generator 232 as a motor such that insufficient torque is compensated for.

Next, when accelerating the vehicle to speed  $V_2$  after running at a constant speed from  $t_1$  to  $t_1'$ , the driver further depresses the accelerator pedal 270. When the torque required by the load consequently increases and exceeds the high torque range of the permissible running range of the engine, the arithmetic and control unit 271 gives a signal to the motor-

generator control unit 272, thereby rotating the motor generator 232 as a motor such that the amount of torque by which the torque exceeds the high torque range of the engine is compensated for by the electromotive power of the motor generator 232. Further, when the rpm of the output shaft 211 exceeds the upper limit number Nb of revolutions for the permissible running range of the engine, the arithmetic and control unit 271 disengages the clutches 221 and 222 via the transmission control unit 273, and brings the engine 21 into an idling state via the engine control unit 274. In this case, the engine 21 may stop. Subsequently, the arithmetic and control unit 271 gives a signal to the motor-generator control unit 272, thereby rotating the motor generator 232 at high speeds so that the required torque is obtained. If the maximum torque generated by the motor generator 232 is insufficient in this case, the clutches 223 and 222 are engaged to couple the motor generators 231 and 232 and thus the electromotive power of the motor generator 231 may compensate for the insufficient torque.

Subsequently, when the running speed of the vehicle is relatively reduced from high speed V2 at time t2, the operation is performed according to the degree to which depression of the accelerator pedal 270 is decreased. In this case, rpm of the rotation shaft 233 are considerably high compared to the degree of depression of the accelerator pedal 270. Alternatively, the brake pedal 275 may be operated at the same time. In both of these cases, in response to a command given by the arithmetic and control unit 271, the clutches 221, 222 and 223 are disengaged via the transmission control unit 273, or else only the clutch 221 is disengaged as necessary and the motor generator 232 and, if necessary, the motor generator 231 are driven as a generator via the motor-generator control unit 272. In this way, a required deceleration operation is carried out. Consequently, the output of the detector 262, which detects torque and rpm, is negative, and the engine 21 is not involved in this state. If the required torque of the load is positive and less than the permissible running range of the engine (which is not illustrated in FIG. 4), the arithmetic and control unit 271 commands the engine control unit to run the engine 21 within the low torque range of the permissible running range of the engine 21. At the same time as this, in order to absorb torque based on the difference between the

outputs of the detectors 261 and 262, the arithmetic and control unit 271 applies a signal to the motor-generator control unit 272, thereby operating the motor generator 232 as a generator. Consequently, the motor generator 232 undergoes dynamic braking so that the difference between torque required by the load and torque required to run the engine 21 within the low torque range of the permissible running range of the engine 21 is absorbed and the generated power is stored in the battery 28 via the motor-generator control unit 272. Thus, since the battery 28 is charged with power generated based on the difference between torque required by the load and torque required to run the engine 21 within the low torque range of the permissible running range of the engine 21, energy loss is eliminated and accordingly energy is more efficiently used. In this case, if the torque difference is larger than the torque that can be absorbed by the motor generator 232 functioning as a generator, torque may be absorbed by the power output of the other motor generator 231 by engaging the clutch 223, thereby causing the motor generator 231 to function as a generator.

When the running speed of the vehicle then drops below the lower limit speed  $V_a$  for the permissible running range of the engine, all the clutches are disengaged to bring the engine into an idling state; while fuel consumption is kept to a minimum, the motor generator 232 operates as a generator, thereby causing the motor generator to undergo dynamic braking such that power generated by the energy produced by the inertial running of the vehicle is supplied to and stored in the battery 28 as a charge current.

According to the embodiment, as described above, the engine operates only in its permissible running range where mileage is high. If the rpm of the shaft 233 coupled to the drive wheels is not larger than the lower limit for the permissible running range of the engine, the vehicle runs only on the electromotive power generated by the motor generator 232 functioning as a motor. If rpm exceeds the high torque range of the permissible running range of the engine, both the engine and the motor generators are driven. If the torque required by a load is not greater than the low torque range of the permissible running range of the engine, the motor generator 232 operates as a generator, thereby storing power output through dynamic braking in the battery. Thus, mileage is very high and, moreover, exhaust gases can be significantly reduced.



In addition, while the motor generator 232 is generating power, the battery is charged with the generated output. This makes it possible to efficiently recover and store energy in addition to the absorption of the torque, and also makes it possible to reduce power consumed to charge the battery 28 nocturnally and so on. Thus, overall fuel costs can be greatly reduced. Further, since the motor generator 231 may be relatively short time rated, a very small and inexpensive one can be used. Accordingly, no significant increase is required in vehicle body weight.

As described above, the present invention provides a vehicle driving device that makes it possible to realize a vehicle that excels in fuel efficiency, is relatively inexpensive, allows a battery to be recharged with energy that might otherwise be lost, and produces less pollution.

In the foregoing, a description has been given in the case of a control system in which the output of the engine and the outputs of the motor generators are detected using means for detecting torque and rpm, and the rpm is used as a reference. However, it is to be understood the invention is not limited to this but the technical concepts of the present invention can also be applied in a control system in which torque is used as a reference.

#### 4. BRIEF DESCRIPTION OF THE DRAWINGS

FIG. 1 is a diagram illustrating the characteristics of curves joining points of equal mileage.

FIG. 2 is a diagram schematically showing the driving device of a vehicle according to an embodiment of the present invention.

FIG. 3A is a diagram of another example of the transmission.

FIG. 3B is a diagram of the mechanism of the transmission shown in FIG. 3A.

FIG. 4 is a diagram illustrating the characteristics of the motion of the present invention.

In the drawings, reference numerals 21 represents an engine (internal combustion engine); 22, a transmission (connecting mechanism); 231, a first motor generator; 232, a second motor generator; 261, a detector for torque and rpm (first detecting means); 262, a detector for torque and rpm (second detecting means); and 27, a control means.

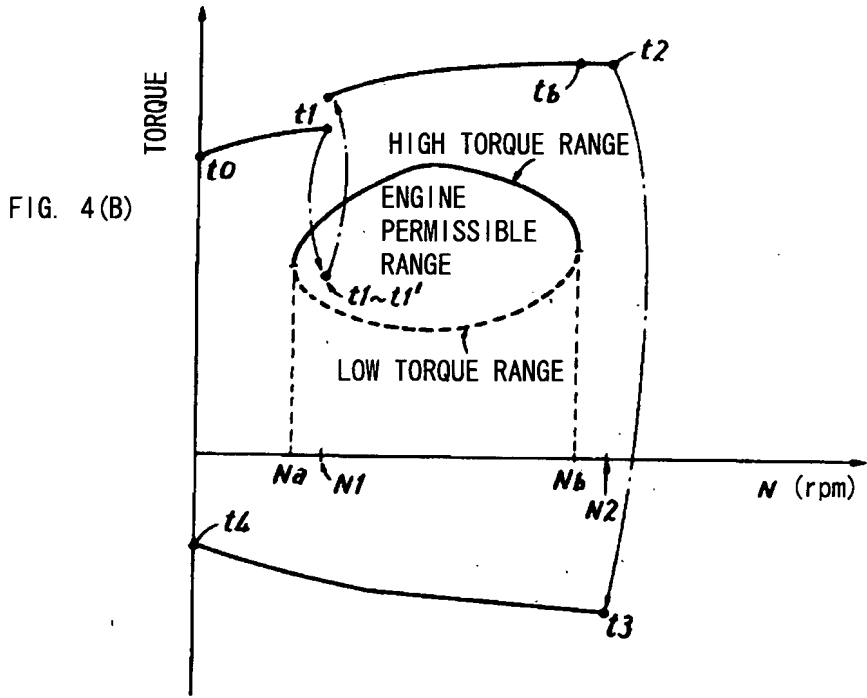
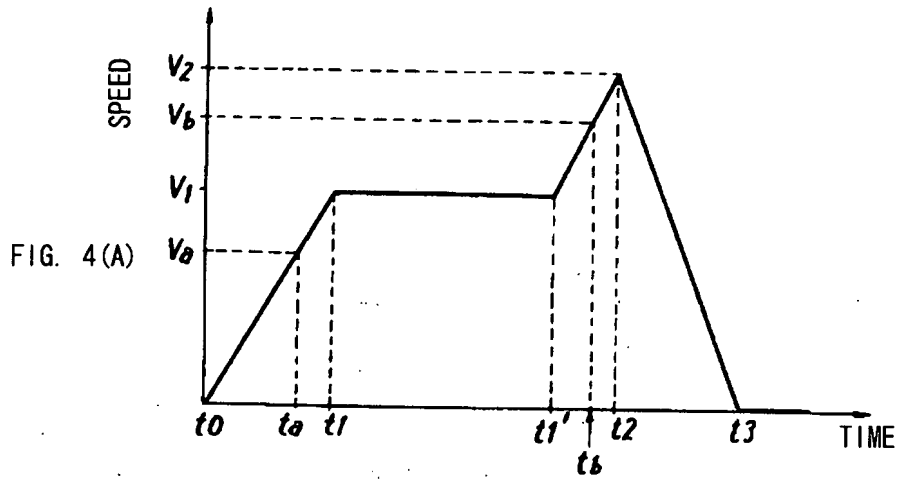

# PATENT ABSTRACTS OF JAPAN

(11)Publication number : 06-144020  
(43)Date of publication of application : 24.05.1994

(51)Int.Cl. B60K 6/00  
B60K 8/00  
B60L 11/14

(21)Application number : 04-294977 (71)Applicant : AQUEOUS RES:KK  
(22)Date of filing : 04.11.1992 (72)Inventor : MOROTO SHUZO  
KAWAMOTO MUTSUMI  
YAMAGUCHI KOZO  
MIYAISHI YOSHINORI

## (54) HYBRID TYPE VEHICLE

### (57)Abstract:

PURPOSE: To travel without generating noise and exhaust gas by driving only a motor while traveling at low and medium speed.

CONSTITUTION: A hybrid type vehicle comprises an engine 11, a first driving device, which is selectively connected to the engine 11 through a first clutch C1, a second driving device, which is selectively connected to the first driving device through a second clutch C2, and drive wheels, which are connected to the second driving device. The first driving device is constituted as a high torque low speed type, and the second driving device is constituted as a low torque high speed type. In accelerating during traveling at low speed and medium speed, in normal traveling and in decelerating the engine 11 is not driven, and therefore the hybrid type vehicle can travel without generating noise and exhaust gas. Since the engine 11 is not suddenly started in full power starting and acceleration, the drive of the first and second driving devices and drive of the engine 6 can be favorably switched.

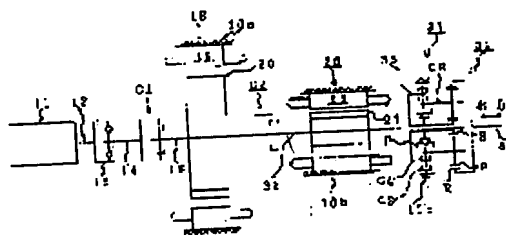

### LEGAL STATUS

[Date of request for examination] 28.10.1999  
[Date of sending the examiner's decision of rejection]  
[Kind of final disposal of application other than the examiner's decision of rejection or application converted registration]  
[Date of final disposal for application]  
[Patent number] 3141262

[Date of registration]

22.12.2000

[Number of appeal against examiner's decision  
of rejection]

[Date of requesting appeal against examiner's  
decision of rejection]

[Date of extinction of right]



## 【特許請求の範囲】

【請求項1】 (a) エンジンと、(b) 該エンジンと第1クラッチを介して選択的に連結された第一の駆動装置と、(c) 該第一の駆動装置と第2クラッチを介して選択的に連結された第二の駆動装置と、(d) 該第二の駆動装置と連結された駆動輪を有するとともに、(e) 前記第一の駆動装置を高トルク低回転型として構成し、(f) 前記第二の駆動装置を低トルク高回転型として構成したことを特徴とするハイブリッド型車両。

【請求項2】 前記第一の駆動装置及び第二の駆動装置は一体的なケース内に配設され、第1クラッチを介してエンジンと連結された請求項1に記載のハイブリッド型車両。

## 【発明の詳細な説明】

【0001】

【産業上の利用分野】本発明は、ハイブリッド型車両に関するものである。

【0002】

【従来の技術】従来、車両はエンジンを駆動することによって発生させた回転を駆動輪に伝達し、走行するようになっているが、騒音や排気ガスが発生するため、電気モータ（以下、「モータ」という。）を駆動することによって走行するようにした電気自動車を提供されている。

【0003】ところが、電気自動車はバッテリーに充電した電気を利用するものであるため、航続距離が短い。そこで、市街地では、エンジンを駆動せず、モータのみを駆動して走行することによって騒音や排気ガスの発生を防止し、高速道路などではエンジンのみを駆動して走行することによって航続距離を長くすることができるハイブリッド型車両が提案されている（特開平2-101903号公報参照）。

【0004】該ハイブリッド型車両は、前後の駆動輪がモータに接続されるとともに、前方の駆動輪はモータのみによって回転させられ、後方の駆動輪はエンジンとモータによって回転させられるようにしている。この場合、前記エンジンとモータは、クラッチを介して連結される。そして、加速時などの高負荷時にはすべてのモータを駆動し、定常走行時のような低負荷時には、前方の駆動輪をモータで回転させるとともに、後方の駆動輪をエンジンで回転させ、エンジンの回転に伴って後方のモータを発電機として使用する。

【0005】

【発明が解決しようとする課題】しかしながら、前記従来のハイブリッド型車両においては、高速走行に対応した特性を有するモータを前後の駆動輪に配設すると、低速走行時にトルクが不足することになる。そこで、例えば、フル発進時や加速時にエンジンによってトルクを補助することが考えられるが、エンジンによるトルクが必要になった場合、瞬時にエンジンを始動することができ

ない。したがって、例えば、ハイブリッド型車両を停止させている間もエンジンをアイドリング状態で待機させておく必要があり、排気ガスが発生してしまう。

【0006】一方、低速走行に対応した特性を有するモータを前後の駆動輪に配設すると、高速走行時においてトルクが不足する。このため、比較的車速が低い中速走行時においてもエンジンによってトルクを補助することが必要となり、市街地でもエンジンを駆動させて走行しなければならない場合が多くなり、排気ガスの発生を防止することができない。

【0007】本発明は、前記従来のハイブリッド型車両の問題点を解決して、低速走行時及び中速走行時においてモータのみを駆動して、騒音や排気ガスを発生させることなく走行することができ、モータの駆動とエンジンの駆動の切り換えを良好に行うことができるハイブリッド型車両を提供することを目的とする。

【0008】

【課題を解決するための手段】そのために、本発明のハイブリッド型車両においては、エンジンと、該エンジンと第1クラッチを介して選択的に連結された第一の駆動装置と、該第一の駆動装置と第2クラッチを介して選択的に連結された第二の駆動装置と、該第二の駆動装置と連結された駆動輪を有する。

【0009】そして、前記第一の駆動装置を高トルク低回転型として構成し、前記第二の駆動装置を低トルク高回転型として構成する。

【0010】

【作用及び発明の効果】本発明によれば、前記のようにハイブリッド型車両は、エンジンと、該エンジンと第1クラッチを介して選択的に連結された第一の駆動装置と、該第一の駆動装置と第2クラッチを介して選択的に連結された第二の駆動装置と、該第二の駆動装置と連結された駆動輪を有する。

【0011】そして、前記第一の駆動装置を高トルク低回転型として構成し、前記第二の駆動装置を低トルク高回転型として構成する。したがって、フル発進時や低速走行における加速時においては、エンジンを停止させ、第1クラッチを解放し、第一の駆動装置を駆動し、第2クラッチを係合し、第二の駆動装置を駆動すると、第一、第二の駆動装置のトルクが合成され、大きな駆動力が発生し、該駆動力によってハイブリッド型車両は走行する。

【0012】また、低速走行における定常走行時や、中速走行における加速時及び定常走行時においては、エンジンを停止させ、第1クラッチを解放し、第一の駆動装置を停止させ、第2クラッチを解放し、第二の駆動装置を駆動すると、第二の駆動装置のみのトルクによって駆動力が発生し、該駆動力によってハイブリッド型車両は走行する。

【0013】そして、低速走行や中速走行における減速

時においては、エンジンを停止させ、第1クラッチを解放し、第一の駆動装置を被駆動状態とし、第2クラッチに係合し、第二の駆動装置を被駆動状態とする。この時、慣性力によってハイブリッド型車両は走行するが、通常の車両のエンジンブレーキと同様に、被駆動状態の第一、第二の駆動装置が負荷となって制動力が発生するとともに、第一、第二の駆動装置において回生が行われる。

【0014】また、低速走行や中速走行においてエンジンによる発電を行う時には、エンジンを駆動し、第1クラッチに係合し、第一の駆動装置を被駆動状態とし、第2クラッチを解放し、第二の駆動装置を駆動する。この時、エンジンのトルクによって被駆動状態の第一の駆動装置において発電が行われ、第二の駆動装置のトルクによって駆動力が発生し、該駆動力によってハイブリッド型車両は走行する。

【0015】一方、高速走行における加速時及び定常走行時においては、エンジンを駆動し、第1クラッチに係合し、第一の駆動装置を停止させ、第2クラッチに係合し、第二の駆動装置を停止させる。この時、エンジンのみのトルクによって駆動力が発生し、該駆動力によってハイブリッド型車両は走行する。また、高速走行における減速時においては、エンジンを被駆動状態とし、第1クラッチに係合し、第一の駆動装置を被駆動状態とし、第2クラッチに係合し、第二の駆動装置を被駆動状態とする。この時、慣性力によってハイブリッド型車両は走行するが、通常の車両のエンジンブレーキと同様に、被駆動状態のエンジン及び第一、第二の駆動装置が負荷となって制動力が発生するとともに、第一、第二の駆動装置において回生が行われる。

【0016】そして、高速走行においてエンジンによる発電を行う時には、エンジンを駆動し、第1クラッチに係合し、第一の駆動装置を被駆動状態とし、第2クラッチに係合し、第二の駆動装置を被駆動状態とする。この時、エンジンのトルクによって駆動力が発生し、該駆動力によってハイブリッド型車両は走行するとともに、被駆動状態の第一、第二の駆動装置において発電が行われる。

【0017】したがって、低速走行及び中速走行における加速時、定常走行時、減速時においてはエンジンが駆動されないので、騒音や排気ガスを発生させることなくハイブリッド型車両を走行させることができる。そして、フル発進時や加速時においてエンジンが急に始動されることがないので、第一、第二の駆動装置の駆動とエンジンの駆動の切換えを良好に行うことができる。

【0018】

【実施例】以下、本発明の実施例について図面を参照しながら詳細に説明する。図1は本発明の実施例を示すハイブリッド型車両の概略図、図2は本発明の実施例を示すハイブリッド型車両の第1断面図、図3は本発明の実

施例を示すハイブリッド型車両の第2断面図である。

【0019】図において、10は第1部分10a、第2部分10b及び第3部分10cから成る駆動装置ケース、11はエンジン、12は該エンジン11が発生したトルクを出力するエンジン出力軸、13は前記エンジン11から急激にトルクが伝達された時に、トルクショックを抑制するダンパである。該ダンパ13はダンパケース13a、二つのスプリング13b、13c、ハブ13dから成り、ダンパケース13aに伝達されたトルクは、二つのスプリング13b、13cによって緩衝され、ハブ13dを介してダンパ出力軸14に伝達される。

【0020】また、C1は油圧サーボC-1によって係脱される第1クラッチ、16は該第1クラッチC1が係合された時にエンジン11のトルクが伝達される第1モータ出力軸である。該第1モータ出力軸16に第一の駆動装置として高トルク低回転型の第1モータ18が設けられる。該第1モータ18は、駆動装置ケース10の第1部分10aに固定されたステータ19及び回転自在に支持されたロータ20から成り、該ロータ20が前記第1モータ出力軸16に固定される。そして、前記ステータ19のステータコイルに電流が供給されると、第1モータ18が駆動され、前記ロータ20に発生した回転は、前記第1モータ出力軸16に伝達される。

【0021】また、前記第1モータ出力軸16に第2クラッチC2が接続され、該第2クラッチC2は油圧サーボC-2によって係脱される。22は該第2クラッチC2が係合された時に前記エンジン11又は第1モータ18のトルクが伝達される第2モータ出力軸である。該第2モータ出力軸22に第二の駆動装置として低トルク高回転型の第2モータ25が設けられる。該第2モータ25は、駆動装置ケース10の第2部分10bに固定されたステータ26及び回転自在に支持されたロータ27から成り、該ロータ27が前記第2モータ出力軸22に固定される。そして、前記ステータ26のステータコイルに電流が供給されると、第2モータ25が駆動され、前記ロータ27に発生した回転は、前記第2モータ出力軸22に伝達される。

【0022】さらに、該第2モータ出力軸22にトランスミッション31が接続される。該トランスミッション31は、プラネタリギヤユニット32、第3クラッチC3、第4クラッチC4及びワンウェイクラッチFから成る。また、前記プラネタリギヤユニット32は、サンギヤS、該サンギヤSと嚙合(しごう)するピニオンP、該ピニオンPと嚙合するリングギヤR及び前記ピニオンPを回転自在に支持するキャリアCRから成る。

【0023】そして、前記サンギヤSがワンウェイクラッチFのインナレース34及び第4クラッチC4のクラッチドラム35に接続され、前記キャリアCRが第2モータ出力軸22、ワンウェイクラッチFのアウタレース

37及び第4クラッチC4のクラッチディスク38に接続され、前記リングギヤRが出力軸40に接続される。

【0024】したがって、前記第3クラッチC3はサンギヤSとキャリヤCR間を係脱し、第4クラッチC4はサンギヤSと駆動装置ケース10の第2部分10b間を係脱する。前記構成のトランスミッション31においては、低速段と高速段を選択することができる。すなわち、低速段において、第3クラッチC3を係合し、第4クラッチC4を解放すると、前記第2モータ出力軸22に伝達された回転はキャリヤCRに入力され、サンギヤSを逆方向に回転させようとするが、サンギヤSが第3クラッチC3によって第2部分10bに固定されるため、リングギヤRを同方向に回転させる。すなわち、リングギヤRから減速された回転が出力される。

【0025】また、高速段において、第3クラッチC3を解放し、第4クラッチC4を係合すると、サンギヤSとキャリヤCR間が第4クラッチC4によって連結されるため、プラネタリギヤユニット32が直結状態となる。したがって、リングギヤRから前記第2モータ出力軸22の回転がそのまま出力される。なお、図2の51はエンジン11の回転数を検出するエンジン回転数センサ、図3の52は出力軸40の回転数を車速として検出する車速センサである。

【0026】ところで、前述したように駆動装置ケース10は、第1部分10a、第2部分10b及び第3部分10cから成るが、本実施例においては、従来のトランスミッションケースをそのまま使用しており、第1部分10aはトルクコンバータハウジングに、第2部分10bはセンタケースに、第3部分10cはエクステンションケースに相当する。

【0027】そして、該従来のトランスミッションケース内に特性の異なる第1、第2モータ18、25を取り付け、エンジン11を駆動したり、第1、第2モータ18、25を選択的に駆動したりしてハイブリッド型車両を走行させることができる。したがって、従来のトランスミッションと互換性を有することができ、ハイブリッド型車両本体を従来のエンジン付きの車両と共通化することが可能になる。

【0028】すなわち、エンジン付きの車両が、電気自動車や一部でエンジンを使用するハイブリッド型車両に徐々に置き換えられる過渡的な時期においては、エンジン付きの車両及び電気自動車のいずれもが使用されることになる。特に、電気自動車を新たに設計し製造するためには、膨大な費用が必要になり、コストが上昇してしまう。そのため、電気自動車の普及が遅れる可能性もある。

【0029】本実施例のように、従来のトランスミッションケースに第1、第2モータ18、25から成る電動モータ装置を配設すると、エンジン付きの車両の車両本体を大幅に変更する必要がなく、トランスミッションと

本実施例の電動モータ装置を変更するだけでそのまま搭載することができる。したがって、コストを低減することができる。従来、従来の自動車技術を利用することができる。

【0030】次に、本発明の実施例を示すハイブリッド型車両の動作について図4～6を併用して説明する。図4は本発明の実施例におけるハイブリッド型車両の作動表を示す図、図5は第1、第2モータの特性図、図6は本発明の実施例を示すハイブリッド型車両の駆動力曲線図である。図4において、○は各要素が駆動されていること又は係合されていることを、△は各要素が被駆動状態にあることを、×は各要素が停止されていること又は解放されていることを示す。

【0031】本発明の実施例においては、エンジン11(図1)のほか、高トルク低回転型の第1モータ18と低トルク高回転型の第2モータ25が駆動源として使用される。図5において、横軸は第1、第2モータ18、25(図1)の回転数を、縦軸は発生するトルクを示す。また、破線Aは第1モータ18の特性図、実線Bは第2モータ25の特性図である。

【0032】前記特性を有する第1、第2モータ18、25をエンジン11と組み合わせることによって、ハイブリッド型車両は図4に示すように作動する。したがって、フル発進時や低速走行における加速時においては、第1、第2モータ18、25を駆動し、大きな駆動力を発生させ、低速走行における定常走行時や、中速走行における加速時及び定常走行時においては、第2モータ25のみを駆動し、高速走行における加速時及び定常走行時においては、エンジン11のみを駆動してハイブリッド型車両を走行させることができる。

【0033】また、減速時には、ハイブリッド型車両の慣性力によって被駆動状態の第1、第2モータ18、25を回生することができる。そして、低速走行や中速走行においてエンジン11による発電を行う時には、エンジン11を駆動して第1モータ18の発電を行い、第2モータ25を駆動してハイブリッド型車両を走行させることができる。一方、高速走行においてエンジン11による発電を行う時には、エンジン11を駆動してハイブリッド型車両を走行させるとともに、被駆動状態の第1、第2モータ18、25において発電を行うことができる。

【0034】以下、各走行状態におけるハイブリッド型車両の作動について説明する。すなわち、ハイブリッド型車両の停止時から図示しないアクセルペダルを踏み込んで発進するフル発進時においては、エンジン11を停止させ、第1クラッチC1を解放し、第1モータ18を駆動し、第2クラッチC2を係合し、第2モータ25を駆動する。この時、第1モータ18及び第2モータ25のトルクが合成され、図6の線Cで示す駆動力が発生し、該駆動力によってハイブリッド型車両は走行する。

【0035】次に、低速走行における加速時において



7  
は、フル発進時と同様にエンジン11を停止させ、第1クラッチC1を解放し、第1モータ18を駆動し、第2クラッチC2を係合し、第2モータ25を駆動する。この時、第1モータ18及び第2モータ25のトルクが合成され、図6の線Cで示す駆動力が発生し、該駆動力によってハイブリッド型車両は走行する。

【0036】また、低速走行における定常走行時においては、エンジン11を停止させ、第1クラッチC1を解放し、第1モータ18を停止させ、第2クラッチC2を解放し、第2モータ25を駆動する。この時、第2モータ25のみのトルクによって、図6の線Dで示す駆動力が発生し、該駆動力によってハイブリッド型車両は走行する。

【0037】そして、低速走行における減速時においては、エンジン11を停止させ、第1クラッチC1を解放し、第1モータ18を被駆動状態とし、第2クラッチC2を係合し、第2モータ25を被駆動状態とする。この時、慣性力によってハイブリッド型車両は走行するが、通常の車両のエンジンブレーキと同様に、被駆動状態の第1、第2モータ18、25が負荷となって制動力が発生するとともに、第1、第2モータ18、25において回生が行われる。

【0038】また、低速走行においてエンジン11による発電を行う時には、エンジン11を駆動し、第1クラッチC1を係合し、第1モータ18を被駆動状態とし、第2クラッチC2を解放し、第2モータ25を駆動する。この時、エンジン11のトルクによって被駆動状態の第1モータ18において発電が行われ、第2モータ25のトルクによって駆動力が発生し、該駆動力によってハイブリッド型車両は走行する。

【0039】次に、中速走行における加速時においては、低速走行における定常走行時と同様にエンジン11を停止させ、第1クラッチC1を解放し、第1モータ18を停止させ、第2クラッチC2を解放し、第2モータ25を駆動する。この時、第2モータ25のみのトルクによって、図6の線Dで示す駆動力が発生し、該駆動力によってハイブリッド型車両は走行する。

【0040】また、中速走行における定常走行時においては、中速走行における加速時と同様にエンジン11を停止させ、第1クラッチC1を解放し、第1モータ18を停止させ、第2クラッチC2を解放し、第2モータ25を駆動する。この時、第2モータ25のみのトルクによって、図6の線Dで示す駆動力が発生し、該駆動力によってハイブリッド型車両は走行する。

【0041】そして、中速走行における減速時においては、低速走行における減速時と同様にエンジン11を停止させ、第1クラッチC1を解放し、第1モータ18を被駆動状態とし、第2クラッチC2を係合し、第2モータ25を被駆動状態とする。この時、慣性力によってハイブリッド型車両は走行するが、通常の車両のエンジン

ブレーキと同様に、被駆動状態の第1、第2モータ18、25が負荷となって制動力が発生するとともに、第1、第2モータ18、25において回生が行われる。

【0042】また、中速走行においてエンジン11による発電を行う時には、エンジン11を駆動し、第1クラッチC1を係合し、第1モータ18を被駆動状態とし、第2クラッチC2を解放し、第2モータ25を駆動する。この時、エンジン11のトルクによって被駆動状態の第1モータ18において発電が行われ、第2モータ25のトルクによって駆動力が発生し、該駆動力によってハイブリッド型車両は走行する。

【0043】そして、高速走行における加速時においては、エンジン11を駆動し、第1クラッチC1を係合し、第1モータ18を停止させ、第2クラッチC2を係合し、第2モータ25を停止させる。この時、エンジン11のみのトルクによって、図6の線E、Fで示す駆動力が発生し、該駆動力によってハイブリッド型車両は走行する。なお、線Eは前記トランスミッション31を低速段に切り換えた場合の、線Fは前記トランスミッション31を低速段に切り換えた場合の駆動力を示す。

【0044】また、高速走行における定常走行時においては、高速走行における加速時と同様にエンジン11を駆動し、第1クラッチC1を係合し、第1モータ18を停止させ、第2クラッチC2を係合し、第2モータ25を停止させる。この時、エンジン11のみのトルクによって、図6の線E、Fで示す駆動力が発生し、該駆動力によってハイブリッド型車両は走行する。

【0045】そして、高速走行における減速時においては、エンジン11を被駆動状態とし、第1クラッチC1を係合し、第1モータ18を被駆動状態とし、第2クラッチC2を係合し、第2モータ25を被駆動状態とする。この時、慣性力によってハイブリッド型車両は走行するが、通常の車両のエンジンブレーキと同様に、被駆動状態のエンジン11及び第1、第2モータ18、25が負荷となって制動力が発生するとともに、第1、第2モータ18、25において回生が行われる。

【0046】また、高速走行においてエンジン11による発電を行う時には、エンジン11を駆動し、第1クラッチC1を係合し、第1モータ18を被駆動状態とし、第2クラッチC2を係合し、第2モータ25を被駆動状態とする。この時、エンジン11のトルクによって駆動力が発生し、該駆動力によってハイブリッド型車両は走行するとともに、被駆動状態の第1、第2モータ18、25において発電が行われる。

【0047】また、エンジンスタート時においては、エンジン11を被駆動状態とし、第1クラッチC1を係合し、第1モータ18を駆動し、第2クラッチC2を解放し、第2モータ25を駆動する。したがって、例えば、中速走行における定常走行中は、第2モータ25のみのトルクによってハイブリッド型車両は走行するが、走行



(7)

【図2】

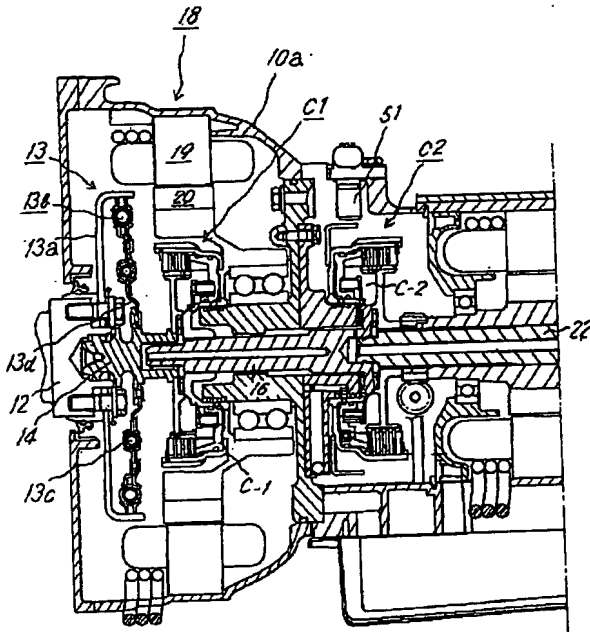

【図5】

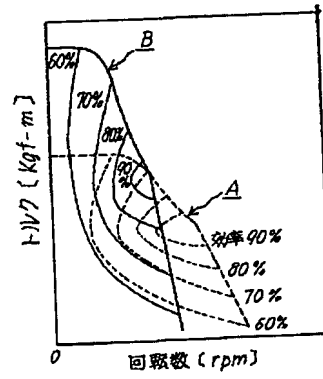

【図3】

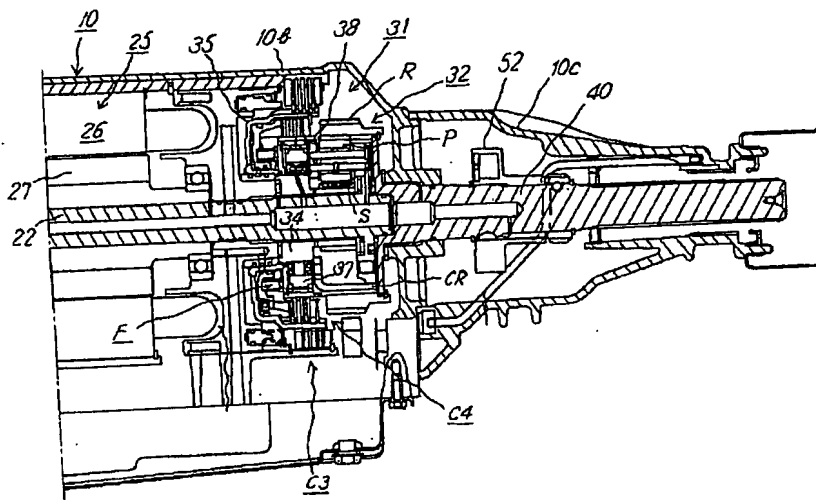

(8)

【図4】

	低速走行				中速走行				高速走行				エンジンスタート	
	フル発進	加速	定常	減速(回生)	エンジンによる発電	加速	定常	減速(回生)	エンジンによる発電	加速	定常	減速(回生)	エンジンによる発電	
エンジン	×	×	×	×	○	×	×	×	○	○	○	△	○	△
第1クラッチ	×	×	×	×	○	×	×	△	○	×	×	△	○	○
第1モーター	○	○	×	△	△	×	×	○	×	○	×	○	○	×
第2クラッチ	○	○	×	○	×	×	○	○	×	○	×	○	○	×
第2モーター	○	○	○	△	○	○	○	△	○	×	×	△	△	○

○: 駆動又は動力解放  
 △: 被駆動又は停止  
 ×: 停止

【図6】

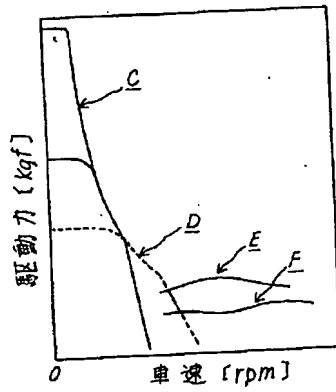

【図7】

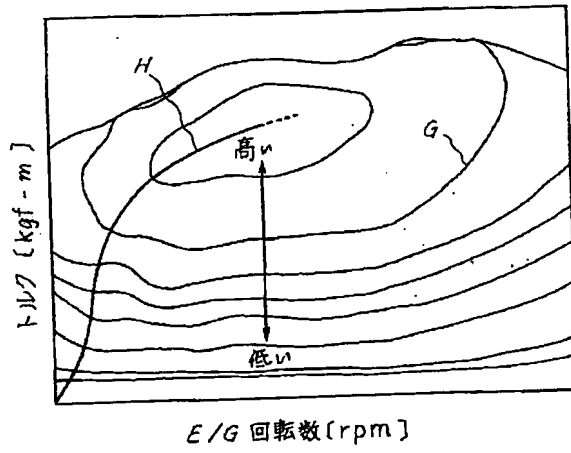

フロントページの続き

(72) 発明者 宮石 善則  
 東京都千代田区外神田2丁目19番12号 株  
 式会社エクス・リサーチ内

【公報種別】特許法第17条の2の規定による補正の掲載  
 【部門区分】第2部門第5区分  
 【発行日】平成13年1月16日(2001.1.16)

【公開番号】特開平6-144020  
 【公開日】平成6年5月24日(1994.5.24)  
 【年通号数】公開特許公報6-1441  
 【出願番号】特願平4-294977  
 【国際特許分類第7版】

B60K 6/00

8/00

B60L 11/14

【F1】

B60K 9/00 Z

B60L 11/14

【手続補正書】

【提出日】平成11年10月28日(1999.10.28)

【手続補正1】

【補正対象書類名】明細書

【補正対象項目名】特許請求の範囲

【補正方法】変更

【補正内容】

【特許請求の範囲】

【請求項1】 (a) エンジンと、(b) 該エンジンと連結された第一の駆動装置と、(c) 該第一の駆動装置と連結された第二の駆動装置と、(d) 該第二の駆動装置と連結された駆動輪とを有するとともに、(e) 前記第一の駆動装置を高トルク低回転型として構成し、

(f) 前記第二の駆動装置を低トルク高回転型として構成し、(g) 前記エンジン、前記第一の駆動装置及び第二の駆動装置を順に、かつ、同軸上に配設することを特徴とするハイブリッド型車両。

【請求項2】 前記第一、第二の駆動装置は一体的なケース内に配設される請求項1に記載のハイブリッド型車両。

【請求項3】 前記第一の駆動装置の径方向における寸法は、第二の駆動装置の径方向における寸法より大きくされる請求項1又は2に記載のハイブリッド型車両。

【手続補正2】

【補正対象書類名】明細書

【補正対象項目名】0007

【補正方法】変更

【補正内容】

【0007】本発明は、前記従来のハイブリッド型車両の問題点を解決して、低速走行時及び中速走行時において駆動装置だけを駆動することによって、騒音、排気ガス等を発生させることなく走行させることができるハイブリッド型車両を提供することを目的とする。

【手続補正3】

【補正対象書類名】明細書

【補正対象項目名】0008

【補正方法】変更

【補正内容】

【0008】

【課題を解決するための手段】そのために、本発明のハイブリッド型車両においては、エンジンと、該エンジンと連結された第一の駆動装置と、該第一の駆動装置と連結された第二の駆動装置と、該第二の駆動装置と連結された駆動輪とを有する。

【手続補正4】

【補正対象書類名】明細書

【補正対象項目名】0009

【補正方法】変更

【補正内容】

【0009】そして、前記第一の駆動装置を高トルク低回転型として構成する。また、前記第二の駆動装置を低トルク高回転型として構成する。さらに、前記エンジン、前記第一の駆動装置及び第二の駆動装置を順に、かつ、同軸上に配設する。

【手続補正5】

【補正対象書類名】明細書

【補正対象項目名】0010

【補正方法】変更

【補正内容】

【0010】

【作用及び発明の効果】本発明によれば、前記のようにハイブリッド型車両においては、エンジンと、該エンジンと連結された第一の駆動装置と、該第一の駆動装置と連結された第二の駆動装置と、該第二の駆動装置と連結された駆動輪とを有する。

【手続補正6】

【補正対象書類名】明細書  
 【補正対象項目名】0011  
 【補正方法】変更  
 【補正内容】

【0011】そして、前記第一の駆動装置を高トルク低回転型として構成する。また、前記第二の駆動装置を低トルク高回転型として構成する。さらに、前記エンジン、前記第一の駆動装置及び第二の駆動装置を順に、かつ、同軸上に配設する。したがって、フル発進時、低速走行における加速時等においては、エンジンを停止させて第一、第二の駆動装置を駆動すると、第一、第二の駆動装置のトルクが合成されて大きな駆動力が発生させられ、該駆動力によってハイブリッド型車両は走行させられる。

【手続補正7】

【補正対象書類名】明細書  
 【補正対象項目名】0012  
 【補正方法】変更  
 【補正内容】

【0012】また、低速走行における定常走行時、中速走行における加速時及び定常走行時等においては、エンジン及び第一の駆動装置を停止させて第二の駆動装置を駆動すると、第二の駆動装置だけのトルクによって駆動力が発生させられ、該駆動力によってハイブリッド型車両は走行させられる。

【手続補正8】

【補正対象書類名】明細書  
 【補正対象項目名】0013  
 【補正方法】変更  
 【補正内容】

【0013】そして、低速走行及び中速走行における減速時等においては、エンジンを停止させて第一、第二の駆動装置を被駆動状態にする。このとき、慣性力によってハイブリッド型車両は走行させられるが、通常の車両のエンジンブレーキと同様に、被駆動状態に置かれた第一、第二の駆動装置が負荷になって制動力が発生するとともに、第一、第二の駆動装置において回生が行われる。

【手続補正9】

【補正対象書類名】明細書  
 【補正対象項目名】0014  
 【補正方法】変更  
 【補正内容】

【0014】また、低速走行、中速走行等においてエンジンによる発電を行う場合、エンジン及び第二の駆動装

置を駆動して第一の駆動装置を被駆動状態にする。このとき、エンジンのトルクによって、被駆動状態に置かれた第一の駆動装置において発電が行われ、第二の駆動装置のトルクによって駆動力が発生させられ、該駆動力によってハイブリッド型車両は走行させられる。

【手続補正10】

【補正対象書類名】明細書  
 【補正対象項目名】0015  
 【補正方法】変更  
 【補正内容】

【0015】一方、高速走行における加速時及び定常走行時等においては、エンジンを駆動して第一、第二の駆動装置を停止させる。このとき、エンジンだけのトルクによって駆動力が発生させられ、該駆動力によってハイブリッド型車両は走行させられる。また、高速走行における減速時等においては、エンジン及び第一、第二の駆動装置を被駆動状態にする。このとき、慣性力によってハイブリッド型車両は走行させられるが、通常の車両のエンジンブレーキと同様に、被駆動状態に置かれたエンジン及び第一、第二の駆動装置が負荷になって制動力が発生するとともに、第一、第二の駆動装置において回生が行われる。

【手続補正11】

【補正対象書類名】明細書  
 【補正対象項目名】0016  
 【補正方法】変更  
 【補正内容】

【0016】そして、高速走行においてエンジンによる発電を行う場合、エンジンを駆動して第一、第二の駆動装置を被駆動状態にする。このとき、エンジンのトルクによって駆動力が発生させられ、該駆動力によってハイブリッド型車両は走行させられるとともに、被駆動状態に置かれた第一、第二の駆動装置において発電が行われる。

【手続補正12】

【補正対象書類名】明細書  
 【補正対象項目名】0017  
 【補正方法】変更  
 【補正内容】

【0017】したがって、低速走行及び中速走行における加速時、定常走行時、減速時等においてはエンジンが駆動されないため、騒音、排気ガス等が発生させることなくハイブリッド型車両を走行させることができる。そして、フル発進時、加速時等においてエンジンが急に始動されることがない。

[Detailed Description of the Invention]

[0001]

[Technical Field]

The present invention relates to hybrid vehicles.

[0002]

[Prior Art]

Conventional vehicles run by driving an engine to generate rotation and transmit the rotation to the driving wheels. However, since these vehicles emit noises and exhaust gases, electric vehicles have been proposed, which run by driving an electric motor (hereinafter, referred to as "motor").

[0003]

However, since electric vehicles use electricity stored in a battery, the propulsion distance is short. To solve the problem, a hybrid vehicle is proposed in which the engine is not driven but only motors are driven to prevent emission of noise and exhaust gases when the vehicle is running in cities and only the engine is driven to increase the propulsion distance when the vehicle is running on highways or the like (see JP02-101903A).

[0004]

This hybrid vehicle is designed such that the front and rear drive wheels are coupled to the front and rear motors respectively so that the front drive wheels are rotated by only the motor and the rear drive wheels are rotated by both the rear motor and the engine, in which case, the engine and the motor are coupled via a clutch. When the vehicle has a large load as during acceleration, all the motors are driven. Conversely, when the vehicle has a small load as while running at constant speed, the front wheels are rotated by the front motor, and the rear drive wheels are rotated by the engine while the rear motor is used as a generator as the engine rotates.

[0005]

[Problem to be Solved by the Invention]

However, in the conventional hybrid vehicle described above, disposing on the front and rear drive wheels the corresponding motors that have characteristics satisfying running at high speeds leads to insufficient torque when the vehicle is running at low speeds. In order to avoid this, for example, the engine may compensate for the insufficiency at the time of starting at full speed and acceleration. In this case,



the engine cannot be started instantaneously when the torque of the engine is required. Accordingly, the engine must be kept on standby in an idling state while the hybrid vehicle is stopped. This results in the production of exhaust gases.

[0006]

On the other hand, disposing on the front and rear drive wheels the corresponding motors that have characteristics satisfying running at low speeds, torque becomes insufficient while running at high speeds. Therefore, the engine is required to make up for the insufficient torque even when the vehicle is running at a relatively low medium speed. As a result, even when running in cities, the vehicle may have to frequently engage the engine and consequently will be unable to prevent production of exhaust gases.

[0007]

It is, accordingly, an object of the present invention to provide a hybrid vehicle that overcomes the foregoing problems of conventional hybrid vehicles so as to allow only motors to be driven during the vehicle's running at low through medium speeds, thereby running without emitting noise or exhaust gases, and so as to allow satisfactory drive switching between the motor and the engine.

[0008]

[Means for Solving the Problem]

In order to solve the problems, a hybrid vehicle according to the present invention includes: an engine; a first driving device selectively coupled to the engine via a first clutch; a second driving device selectively coupled to the first driving device via a second clutch; and drive wheels coupled to the second driving device.

[0009]

The first driving device is of a high torque low revolution type whereas the second driving device is of a low torque high revolution type.

[0010]

[Operation and Effect of the Invention]

According to the present invention, as described above, a hybrid vehicle includes: an engine; a first driving device selectively coupled to the engine via a first clutch; a second driving device selectively coupled to the first driving device via a second clutch; and drive wheels coupled to the second driving device.

[0011]

In addition, the first driving device is of a high torque low revolution type whereas the second driving device is of a low torque high revolution type. To be specific, when the hybrid vehicle is starting at full speed or accelerating while running at low speeds, the engine is stopped, the first clutch is released, the first driving device is driven, the second clutch is engaged, and the second driving device is driven. Consequently the torques of the first and second driving devices are combined to produce a more powerful force, with which the hybrid vehicle runs.

[0012]

When the hybrid vehicle is running at a constant low speed, accelerating while running at medium speeds, or running at a constant medium speed, the engine is stopped, the first clutch is released, the first driving device is stopped, the second clutch is released, and the second driving device is driven. Consequently, the torque of the second driving device generates a driving force with which the hybrid vehicle runs.

[0013]

When the hybrid vehicle is decelerating while running at low or medium speeds, the engine is stopped, the first clutch is released, the first driving device is passively driven, the second clutch is engaged, and the second driving device is passively driven. At this time, the hybrid vehicle runs on inertia. However, as in conventional engine brakes, the first and second driving devices being passively driven become loads to generate braking force and, also, energy is regenerated in the first and second driving devices.

[0014]

When power is generated by the engine while the hybrid vehicle is running at low or medium speeds, the engine is driven, the first clutch is engaged, the first driving device is passively driven, the second clutch is released, and the second driving device is driven. At this time, power is generated in the first driving device being passively driven by the torque of the engine, a driving force is generated by the torque of the second driving device, and consequently the hybrid vehicle runs with this driving force.

[0015]

When the hybrid vehicle is accelerating while running at high speeds or running at a constant high speed, the engine is

driven, the first clutch is engaged, the first driving device is stopped, the second clutch is engaged, and the second driving device is stopped. At this time, a driving force is generated by the torque of only the engine, and the hybrid vehicle runs with this driving force. When the hybrid vehicle is decelerating while running at high speeds, the engine is passively driven, the first clutch is engaged, the first driving device is passively driven, the second clutch is engaged, and the second driving device is passively driven. At this time, the hybrid vehicle runs on inertia. However, as in conventional engine brakes, the engine and first and second driving devices being passively driven become loads to generate braking force and, also, energy is regenerated in the first and second driving devices.

[0016]

When power is generated by the engine while the vehicle is running at high speeds, the engine is driven, the first clutch is engaged, the first driving device is passively driven, the second clutch is engaged, and the second driving device is passively driven. At this time, a driving force is generated by the torque of the engine, the hybrid vehicle runs with this driving force, and power is generated in the first and second driving devices being passively driven.

[0017]

Thus, the engine is not driven when the hybrid vehicle is accelerating while running at a low or medium speed, when the vehicle is running at a constant low or medium speed, or when the vehicle is decelerating while running at a low or medium speed. This enables the hybrid vehicle to run without emitting noise or exhaust gases. In addition, the engine is prevented from starting suddenly when the vehicle is starting at full speed or accelerating. This ensures satisfactory drive switching between the first and second driving devices, and the engine.

[0018]

[Embodiments]

The embodiments of the present invention will now be described below with reference to the attached drawings. FIG. 1 is a schematic view of a hybrid vehicle according to the embodiment of the present invention. FIGS. 2 and 3 are respectively first and second sectional views of the hybrid vehicle according to the embodiment of the present invention.

[0019]

In FIGS. 1 and 2, reference numeral 10 is a driving device case including a first portion 10a, second portion 10b, and third portion 10c. Reference numeral 11 represents an engine; 12, an engine output shaft that outputs torque generated by the engine 11; and 13, a damper that reduces torque shock when torque is suddenly transmitted from the engine 11. The damper 13 includes a damper case 13a, two springs 13b, 13c, and a hub 13d and is designed such that torque transmitted to the damper case 13a is absorbed by the two springs 13b, 13c and transmitted to a damper output shaft 14 via the hub 13d.

[0020]

Reference letter C1 represents a first clutch engaged or disengaged by a hydraulic servo C-1. Reference numeral 16 represents a first motor output shaft to which the torque of the engine 11 is transmitted when the first clutch C1 is engaged. Disposed on the first motor output shaft 16 is a first driving device, namely, a first motor 18 of a high torque, low revolution type. The first motor 18 includes: a stator 19 fixed to the first portion 10a of the driving device case 10; and a rotor 20 so supported as to be freely rotatable. The rotor 20 is fixed to the first motor output shaft 16. The first motor 18 is driven by a supply of current to the stator coil of the stator 19 and consequently rotation produced in the rotor 20 is transmitted to the first motor output shaft 16.

[0021]

Coupled to the first motor output shaft 16 is a second clutch C2, which is engaged or disengaged by a hydraulic servo C-2. Reference numeral 22 represents a second motor output shaft to which the torque of the engine 11 or first motor 18 is transmitted when the second clutch C2 is engaged. Disposed on the second motor output shaft 22 is a second driving device, namely, a second motor 25 of a low torque high revolution type. The second motor 25 includes: a stator 26 fixed to the second portion 10b of the driving device case 10; and a rotor 27 so supported as to be freely rotatable. The rotor 27 is fixed to the second motor output shaft 22. The second motor 25 is driven by a supply of current to the stator coil of the stator 26 and consequently rotation produced in the rotor 27 is transmitted to the second motor output shaft 22.

[0022]

Coupled to the second motor output shaft 22 is a

transmission 31. The transmission 31 includes a planetary gear unit 32, a third clutch C3, a fourth clutch C4, and a one-way clutch F. The planetary gear unit 32 includes: a sun gear S, a pinion P meshed with the sun gear S, a ring gear R meshed with the pinion P, and a carrier CR supporting the pinion P so as to be freely rotatable.

[0023]

The sun gear S is connected to an inner race 34 of the one-way clutch F and a clutch drum 35 of the fourth clutch C4. The carrier CR is connected to the second motor output shaft 22, the outer race 37 of the one-way clutch F, and a clutch disk 38 of the fourth clutch C4. Consequently the ring gear R is connected to an output shaft 40.

[0024]

Therefore, the third clutch C3 causes the sun gear S to engage or disengage with the carrier CR, and the fourth clutch C4 causes the sun gear S to engage or disengage with the second portion 10b of the driving device case 10. The transmission 31 having the configuration described above allows the selection of a lower gear or a higher gear. Specifically, for a lower gear, when the third clutch C3 is engaged and the fourth clutch C4 is released, rotation transmitted to the second motor output shaft 22 is input to the carrier CR, leading to the reverse rotation of the sun gear S. However, since the sun gear S is fixed to the second portion 10b by the third clutch C3, the ring gear R is rotated in the same direction. In other words, rotation at reduced speed is output from the ring gear R.

[0025]

For a higher gear, when the third clutch C3 is released and the fourth clutch C4 is engaged, the sun gear S and the carrier CR are coupled by the fourth clutch C4, and the planetary gear unit 32 is directly coupled. Accordingly, the ring gear R outputs the rotation of the second motor output shaft 22 as it is. In FIG. 2, reference numeral 51 represents a sensor for detecting the number of revolutions of the engine 11. In FIG. 3, reference numeral 52 represents a vehicle speed sensor that interprets the number of revolutions of the output shaft 40 as vehicle speed.

[0026]

Incidentally, as mentioned above, the driving device case 10 includes the first portion 10a, second portion 10b and third portion 10c. However, the present embodiment uses a

conventional transmission case as it is; and the first portion 10a corresponds to a torque converter housing, the second portion 10b, a center case, the third portion 10c, an extension case.

[0027]

The first and second motors 18, 25 of different characteristics are mounted in the above-mentioned conventional transmission case, and the engine 11 is driven or the first motor 18 or second motor 25 is selectively driven, thereby running the hybrid vehicle. Accordingly, this is compatible with a conventional transmission, thus allowing the body of the hybrid vehicle to be made common to a conventional engine vehicle.

[0028]

In other words, at a time of transition from engine vehicles to electric vehicles or hybrid vehicles that partly use engines, both engine vehicles and electric vehicles are usable. Designing and manufacturing new electric vehicles is very costly. That might slow the spread of electric vehicles.

[0029]

As in the present embodiment, disposing in a conventional transmission case an electric motor device that includes the first and second motors 18, 25 eliminates the need to significantly change the body of the engine vehicle and allows the electric motor device of the present embodiment to be mounted as it is only by simply replacing the transmission with it. This reduces costs and allows conventional vehicle technologies to be utilized.

[0030]

Next, referring to FIGS. 4 to 6, the motion of the hybrid vehicle according to the embodiment of the present invention will be described. FIG. 4 shows a table explaining the operations of the hybrid vehicle according to the embodiment of the present invention. FIG. 5 is a diagram illustrating the characteristics of the first and second motors, and FIG. 6 is a diagram illustrating the driving force curves of the hybrid vehicle according to the embodiment of the present invention. In FIG. 4, a symbol  $\circ$  indicates that each element is driven or engaged,  $\square$  indicates that each element is passively driven,  $\times$  indicates that each element is stopped or released.

[0031]

The embodiment of the present invention uses, as drive

sources, the first motor 18 of high torque low revolution type and the second motor 25 of low torque high revolution type, in addition to the engine 11 (see FIG. 1). In FIG. 5, the horizontal axis shows the number of revolutions of the first and second motors 18, 25 (see FIG. 1), and the vertical axis shows the torque generated by them. Broken lines A represent the characteristics of the first motor 18, and solid lines B the characteristics of the second motor 25.

[0032]

By combining the first and second motors 18, 25, which have the above-described characteristics, with the engine 11, the hybrid vehicle operates as shown in FIG. 4. That is, the hybrid vehicle runs as follows: while the vehicle is starting at full speed or accelerating while running at low speeds, the first and second motors 18, 25 are driven to generate a powerful driving force; while the vehicle is running at a constant low speed or accelerating while running at a medium speed or running at a constant medium speed, only the second motor 25 is driven; and while the vehicle is accelerating while running at high speeds or running at a constant high speed, only the engine 11 is driven.

[0033]

In addition, while the hybrid vehicle is decelerating, energy can be regenerated by the first and second motors 18, 25 being passively driven by inertia of the hybrid vehicle. When power is generated by the engine 11 while the vehicle is running at low or medium speeds, the engine 11 is driven to cause the first motor 18 to generate power and the second motor 25 is driven to run the hybrid vehicle. On the other hand, when power is generated by the engine 11 while the vehicle is running at high speeds, the engine 11 is driven to run the hybrid vehicle and power can be generated in the first and second motors 18, 25 being passively driven.

[0034]

Next, a description is given of the operation of the hybrid vehicle in each running state. When the hybrid vehicle is started at full speed from standstill by depressing an accelerator pedal (not shown), the engine 11 is stopped, the first clutch C1 is released, the first motor 18 is driven, the second clutch C2 is engaged, and the second motor 25 is driven. At this time, the torques of the first and second motors 18, 25 are combined to generate a driving force indicated by the line

C shown in FIG. 6, and consequently the hybrid vehicle runs with this driving force.

[0035]

When the hybrid vehicle accelerates while running at low speeds, the engine 11 is stopped, the first clutch C1 is released, the first motor 18 is driven, the second clutch C2 is engaged, and the second motor 25 is driven, as in the case where the vehicle starts at full speed. At this time, the torques of the first and second motors 18, 25 are combined to generate a driving force indicated by the line C shown in FIG. 6, and consequently the hybrid vehicle runs with this driving force.

[0036]

When the hybrid vehicle runs at a constant low speed, the engine 11 is stopped, the first clutch C1 is released, the first motor 18 is stopped, the second clutch C2 is released, and the second motor 25 is driven. At this time, a driving force indicated by the line D shown in FIG. 6 is generated by the torque of only the second motor 25 and the hybrid vehicle runs with this driving force.

[0037]

When the hybrid vehicle decelerates while running at low speeds, the engine 11 is stopped, the first clutch C1 is released, the first motor 18 is passively driven, the second clutch C is engaged, and the second motor 25 is passively driven. At this time, the hybrid vehicle runs on inertia. However, as in the conventional engine brakes, the first and second motors 18, 25 being passively driven become loads to generate braking force and, also, energy is regenerated in the first and second motors 18, 25.

[0038]

When power is generated by the engine 11 while the hybrid vehicle is running at low speeds, the engine 11 is driven, the first clutch C1 is engaged, the first motor 18 is passively driven, the second clutch C2 is released, and the second motor 25 is driven. At this time, power is generated in the first motor 18 being passively driven by the torque of the engine 11, a driving force is generated by the torque of the second motor 25, and consequently the hybrid vehicle runs with this driving force.

[0039]

When the hybrid vehicle accelerates while running at a



medium speed, the engine 11 is stopped, the first clutch C1 is released, the first motor 18 is stopped, the second clutch C2 is released, and the second motor 25 is driven, as in the case where the vehicle is running at a constant low speed. At this time, a driving force indicated by the line D shown in FIG. 6 is generated by the torque of only the second motor 25, and the hybrid vehicle runs with this driving force.

[0040]

When the hybrid vehicle runs at a constant medium speed, the engine 11 is stopped, the first clutch C1 is released, the first motor 18 is stopped, the second clutch C2 is released, and the second motor 25 is driven, as in the case where the vehicle is accelerating while running at a medium speed. At this time, a driving force indicated by the line D shown in FIG. 6 is generated by the torque of only the second motor 25, and the hybrid vehicle runs with this driving force.

[0041]

When the hybrid vehicle decelerates while running at medium speeds, the engine 11 is stopped, the first clutch C1 is released, the first motor 18 is passively driven, the second clutch C is engaged, and the second motor 25 is passively driven as in the case where the vehicle decelerates while running at low speeds. At this time, the hybrid vehicle runs on inertia. However, as in conventional engine brakes, the first and second motors 18, 25 being passively driven become loads to generate braking force and, also, energy is regenerated in the first and second motors 18, 25.

[0042]

When power is generated by the engine 11 while the hybrid vehicle is running at medium speeds, the engine 11 is driven, the first clutch C1 is engaged, the first motor 18 is passively driven, the second clutch C2 is released, and the second motor 25 is driven. At this time, power is generated in the first motor 18 being passively driven by the torque of the engine 11, a driving force is generated by the torque of the second motor 25, and consequently the hybrid vehicle runs with this driving force.

[0043]

When the hybrid vehicle accelerates while running at high speeds, the engine 11 is driven, the first clutch C1 is engaged, the first motor 8 is stopped, the second clutch C2 is engaged, and the second motor 25 is stopped. At this time,

driving forces indicated by the lines E, F shown in FIG. 6 are generated by the torque of only the engine 11 and consequently the hybrid vehicle runs with these driving forces. Here, the line E indicates a driving force generated when the transmission 31 is switched to a lower gear, and the line F indicates a driving force generated when the transmission 31 is switched to a higher gear.

[0044]

When the hybrid vehicle is running at a constant high speed, the engine 11 is driven, the first clutch C1 is engaged, the first motor 18 is stopped, the second clutch C2 is engaged, and the second motor 25 is stopped, as in the case where the vehicle is accelerating while running at high speeds. At this time, driving forces indicated by the lines E, F shown in FIG. 6 are generated by the torque of only the engine 11 and consequently the hybrid vehicle runs with these driving forces.

[0045]

When the hybrid vehicle is decelerating while running at high speeds, the engine 11 is passively driven, the first clutch C1 is engaged, the first motor 18 is passively driven, the second clutch C2 is engaged, and the second motor 25 is passively driven. At this time, the hybrid vehicle runs on inertia. However, as in conventional engine brakes, the engine 11 and first and second motors 18, 25 being passively driven become loads to generate braking force and, also, energy is regenerated in the first and second motors 18, 25.

[0046]

When power is generated by the engine 11 while the vehicle is running at high speeds, the engine 11 is driven, the first clutch C1 is engaged, the first motor 18 is passively driven, the second clutch C2 is engaged and the second motor 25 is passively driven. At this time, a driving force is generated by the torque of the engine 11, the hybrid vehicle runs with this driving force, and power is generated in the first and second motors 18, 25 being passively driven.

[0047]

When the engine starts, on the other hand, the engine 11 is passively driven, the first clutch C1 is engaged, the first motor 18 is driven, the second clutch C2 is released, and the second motor 25 is driven. Accordingly, for example, while running at a constant medium speed, the hybrid vehicle runs with the torque of only the second motor 25. However, when the

engine 11 is started while running in this state, the first motor 18 is driven, and the engine 11 is rotated by the driving force of the first motor 18.

[0048]

As described above, the engine 11 is capable of generating power while the hybrid vehicle is running at low, medium, or high speeds. In this case, generating power according to the maximum fuel efficiency curve ensures optimum efficiency. FIG. 7 is a diagram illustrating the maximum fuel efficiency curve. In FIG. 7, the horizontal axis shows the number of revolutions of the engine (E/G) 11, shown in FIG. 1, and the vertical axis shows torque.

[0049]

In the drawing, each line G joins points where fuel consumption rates are equal, and the line H is the maximum fuel efficiency curve. When power is generated, the number of revolutions and torque of the engine 11 are set in accordance with the maximum fuel efficiency curve H. In the present embodiment, the first driving device is composed of the single first motor 18, and the second driving device is composed of the single second motor 25. However, each driving device may be composed of a plurality of motors. For instance, the second driving device may be composed of a plurality of motors so as to have a low torque high revolution characteristic as a whole.

[0050]

In the present embodiment, the first and second driving devices are disposed in the same driving device case 10. However, the hybrid vehicle may be configured so as to drive its front and rear wheels with the first and second driving devices, respectively. In this case, the output shaft of the first driving device is coupled to the front wheels, the second clutch is disposed between the second driving device and the rear wheels, and the second clutch is engaged to connect the first and second driving devices via the front and rear wheels and the ground. Such a configuration allows a hybrid vehicle to run on four-wheel drive where a more powerful driving force is required.

[Brief Description of the Drawings]

FIG. 1 is a schematic view of a hybrid vehicle according to the embodiment of the present invention.

FIG. 2 is a first sectional view of the hybrid vehicle according to the embodiment of the present invention.

FIG. 3 is a second sectional view of the hybrid vehicle according to the embodiment of the present invention.

FIG. 4 is a table illustrating the operation of the hybrid vehicle according to the embodiment of the present invention.

FIG. 5 is a diagram illustrating the characteristics of the first and second motors.

FIG. 6 is a diagram illustrating the driving force curves of the hybrid vehicle according to the embodiment of the present invention.

FIG. 7 is a diagram illustrating the maximum fuel efficiency curve.

[Description of Reference Numerals]

10 DRIVING DEVICE CASE

11 ENGINE

18 FIRST MOTOR

25 SECOND MOTOR

C1 FIRST CLUTCH

C2 SECOND CLUTCH

# PATENT ABSTRACTS OF JAPAN

(11)Publication number : 04-341657  
 (43)Date of publication of application : 27.11.1992

(51)Int.Cl. F16H 61/10  
 // F16H 59:18  
 F16H 59:24  
 F16H 59:44

(21)Application number : 03-008956 (71)Applicant : NISSAN MOTOR CO LTD  
 (22)Date of filing : 29.01.1991 (72)Inventor : KATO YUJI

## (54) SHIFT PATTERN SELECT CONTROLLER OF AUTOMATIC TRANSMISSION

(57)Abstract:

PURPOSE: To perform the select control of a power pattern so optionally according to the individuality of a driver by renewing compensation data on the basis of accelerator work of the driver, and compensating the reference select judging data of accelerator operating speed by means of the compensation data.

CONSTITUTION: Reference select judging data of accelerator operating speed detected by a means (d) and compensation data are set each by each of maps (e), (f) according to throttle opening and car speed detected by each of means (b), (c). In addition, the compensation data are renewed by a means (g) under the specified running conditions. Moreover, each of data is extracted from the maps (e), (f) by respective means (h), (i), while these extracted data are summed up by a means (j), operating the select judged value. When the accelerator operating speed goes beyond this select judged value and a usual shift pattern is selected by a means (a), it is selected to a shift

pattern, where a yet more powerful run is securable, by a means (k). With this constitution, optimum select control conformed to an intention of each driver is thus performed.

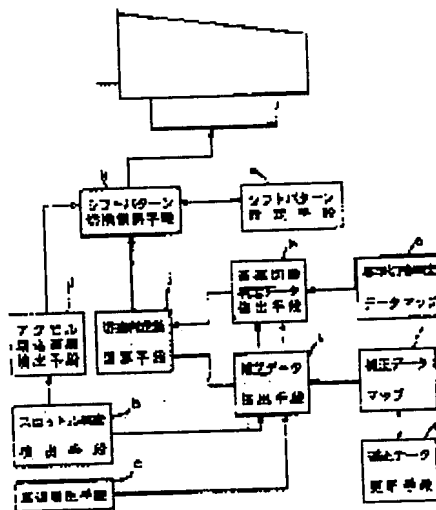

### LEGAL STATUS

- [Date of request for examination]
- [Date of sending the examiner's decision of rejection]
- [Kind of final disposal of application other than the examiner's decision of rejection or application converted registration]
- [Date of final disposal for application]
- [Patent number]
- [Date of registration]
- [Number of appeal against examiner's decision]

of rejection]

[Date of requesting appeal against examiner's  
decision of rejection]

[Date of extinction of right]

(51) Int.Cl. <sup>5</sup>	識別記号	庁内整理番号	F I	技術表示箇所
F 1 6 H 61/10		8207-3 J		
// F 1 6 H 59:18		8207-3 J		
59:24		8207-3 J		
59:44		8207-3 J		

審査請求 未請求 請求項の数1(全 6 頁)

(21) 出願番号 特願平3-8956

(22) 出願日 平成3年(1991)1月29日

(71) 出願人 000003997

日産自動車株式会社  
神奈川県横浜市神奈川区宝町2番地

(72) 発明者 加藤 雄司

神奈川県横浜市神奈川区宝町2番地 日産  
自動車株式会社内

(74) 代理人 弁理士 平田 義則 (外1名)

(54) 【発明の名称】 自動変速機のシフトパターン切換制御装置

(57) 【要約】

【目的】 電子制御により2つ以上設定されているのシフトパターンをアクセルワークに基づいて自動的に切り換える自動変速機のシフトパターン切換制御装置において、ドライバーの個性の違いによりアクセルワークに個人差があっても各ドライバーの要求意思に合致したパワーパターンへの切換えタイミングを得ること。

【構成】 ドライバーのアクセルワークの監視に基づく学習制御により補正データを随時更新しながら作成し、アクセル踏込速度の基準切換判定データをこの補正データにより補正してパワーパターンへの切換え制御を行なう構成とした。

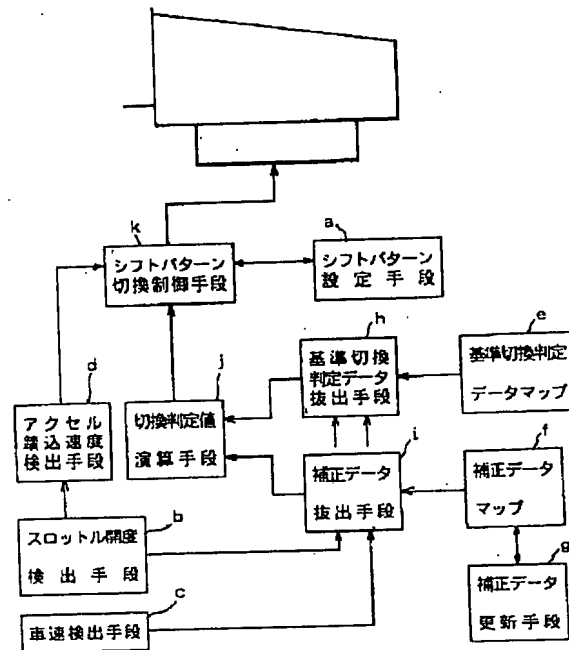

## 【特許請求の範囲】

【請求項1】 少なくとも2つ以上のシフトパターンが設定されているシフトパターン設定手段と、スロットル開度を検出するスロットル開度検出手段と、車速を検出する車速検出手段と、アクセル踏込速度を検出するアクセル踏込速度検出手段と、アクセル踏込速度の基準切替判定データがスロットル開度と車速に応じて設定されている基準切替判定データマップと、アクセル踏込速度の補正データがスロットル開度と車速に応じて設定されている補正データマップと、所定の走行条件下でアクセル踏込速度を監視しながら学習制御により前記補正データを更新する補正データ更新手段と、基準切替判定マップからスロットル開度検出値と車速検出値に応じた基準切替判定データを抜き出す基準切替判定データ抜出手段と、補正データマップからスロットル開度検出値と車速検出値に応じた補正データを抜き出す補正データ抜出手段と、抜き出された判定データと補正データを合算して切替判定値を求める切替判定値演算手段と、アクセル踏込速度検出値が切替判定値を超えた時であって、通常のシフトパターンが選択されている時には、通常のシフトパターンよりパワフルな走行が得られるシフトパターンに切り換える指令を出力するシフトパターン切替制御手段と、を備えていることを特徴とする自動変速機のシフトパターン切替制御装置。

## 【発明の詳細な説明】

## 【0001】

【産業上の利用分野】本発明は、電子制御により2つ以上設定されているシフトパターンをアクセルワークに基づいて自動的に切り換える自動変速機のシフトパターン切替制御装置に関する。

## 【0002】

【従来の技術】従来、自動変速機のシフトパターン切替制御装置としては、例えば、『自動車工学Vol. 37 No. 7』（昭和63年6月；株式会社鉄道日本社発行）の214～249ページに記載のものが知られている。

【0003】上記従来出典には、シフトパターンとして、通常走行に適したエコノミーパターンと、登坂時や追越し等、よりパワフルな走りが欲しい時に適したパワーパターンが設定されていて、ATモードスイッチでオートを選択した場合、ドライバーのアクセルワーク（アクセル踏込速度）に応じてエコノミーパターンとパワーパターンを自動的に切替える技術が示されている。

## 【0004】

【発明が解決しようとする課題】しかしながら、上記従来の自動変速機のシフトパターン切替制御装置にあっては、エコノミーパターンからパワーパターンへの切替判定は、スロットル開度と車速に応じてアクセル踏込速度の固定値による切替判定データが設定されている切替判定データマップを用いて行なうようにしている為、ドライバーの個性の違いによりパワーパターンを要求してい

ないのにパワーパターンへ切り換わったり、パワーパターンを要求しているのにパワーパターンへ切り換わったりして使い勝手にバラツキが出てしまう。

【0005】即ち、高アクセル踏込速度によりアクセルワークを行なうドライバーの場合、平坦路走行時等においてもパワーパターンへ切り換わり易いし、その切替頻度も高くなる。これに対し、高アクセル踏込速度によりアクセルワークを行なうドライバーの場合、登坂時や追越し等であってパワーパターンが欲しい時にでもパワーパターンへ切り換わらなかつたりするし、その切替頻度も低くなる。

【0006】本発明は、上記のような問題に着目してなされたもので、電子制御により2つ以上設定されているシフトパターンをアクセルワークに基づいて自動的に切り換える自動変速機のシフトパターン切替制御装置において、ドライバーの個性の違いによりアクセルワークに個人差があっても各ドライバーの要求意思に合致したパワーパターンへの切替えタイミングを得ることを課題とする。

## 【0007】

【課題を解決するための手段】上記課題を解決するため本発明の自動変速機のシフトパターン切替制御装置では、ドライバーのアクセルワークの監視に基づく学習制御により補正データを随時更新しながら作成し、アクセル踏込速度の基準切替判定データをこの補正データにより補正してパワーパターンへの切替え制御を行なう手段とした。

【0008】即ち、図1のクレーム対応図に示すように、少なくとも2つ以上のシフトパターンが設定されているシフトパターン設定手段aと、スロットル開度を検出するスロットル開度検出手段bと、車速を検出する車速検出手段cと、アクセル踏込速度を検出するアクセル踏込速度検出手段dと、アクセル踏込速度の基準切替判定データがスロットル開度と車速に応じて設定されている基準切替判定データマップeと、アクセル踏込速度の補正データがスロットル開度と車速に応じて設定されている補正データマップfと、所定の走行条件下でアクセル踏込速度を監視しながらの学習制御により前記補正データを更新する補正データ更新手段gと、基準切替判定マップeからスロットル開度検出値と車速検出値に応じた基準切替判定データを抜き出す基準切替判定データ抜出手段hと、補正データマップfからスロットル開度検出値と車速検出値に応じた補正データを抜き出す補正データ抜出手段iと、抜き出された判定データと補正データを合算して切替判定値を求める切替判定値演算手段jと、アクセル踏込速度検出値が切替判定値を超えた時であって、通常のシフトパターンが選択されている時には、通常のシフトパターンよりパワフルな走行が得られるシフトパターンに切り換える指令を出力するシフトパターン切替制御手段kとを備えていることを特徴とす



る。

【0009】

【作用】まず、補正データ更新手段gにおいて、直進走行時等の所定の走行条件下でアクセル踏込速度を監視しながらの学習制御により補正データマップfに設定されている補正データが更新される。

【0010】そして、アクセルペダルを急踏みしての走行時等であって、アクセル踏込速度検出手段dからのアクセル踏込速度検出値が切換判定値演算手段jからの切換判定値を超えた時であって、通常のシフトパターンが選択されている時には、シフトパターン切換制御手段kにおいて、通常のシフトパターンよりパワフルな走行が得られるシフトパターンに切り換える指令が出力される。

【0011】ここで、切換判定値は、基準切換判定データ抜出手段hにおいて、基準切換判定マップeからスロットル開度検出値と車速検出値に応じて抜き出された基準切換判定データと、補正データ抜出手段iにおいて、補正データマップfからスロットル開度検出値と車速検出値に応じて抜き出された補正データとを合算して求められる。

【0012】

【実施例】以下、本発明の実施例を図面に基づいて説明する。

【0013】構成を説明する。

【0014】図2は本発明実施例のシフトパターン切換制御装置が適用された自動変速機を示す全体システム図である。

【0015】実施例の自動変速機は、図2に示すように、エンジン1に連結される主変速機としてのトルクコンバータ2と、副変速機としての遊星ギヤ3とを有する。そして、変速要素としての変速クラッチ・ブレーキ類4が遊星ギヤ3と共に搭載され、この変速クラッチ・ブレーキ類4を各シフト位置に応じて締結または解放する油圧制御手段としてコントロールバルブ5が設けられ、このコントロールバルブ5にはオイルポンプ6から加圧作動油が供給される。また、コントロールバルブ5には、制御アクチュエータとして、ライン圧ソレノイド7、ロックアップソレノイド8、シフトソレノイドA9、シフトソレノイドB10、タイミング制御用ソレノイド11が付設されている。

【0016】そして、前記各ソレノイド7、8、9、10、11には、それぞれに対しクラッチ油圧作動信号、ロックアップ作動信号、変速指令、変速指令、油圧タイミング信号を出力するコントロールユニット12（マイクロコンピュータ主体）が接続されている。このコントロールユニット12には、入力情報を得る手段として、油温センサ13、スロットルセンサ14（スロットル開度検出手段に相当）、エンジン回転センサ15、車速センサ16（車速検出手段に相当）、インヒビタースイッ

チ17、ATモードスイッチ18、ASCDスイッチ19が接続されている。尚、コントロールユニット12には、シフトパターンとしてパワーパターンが選択されている時に車室内に点灯表示するパワーパターンインジケータ20も接続されている。

【0017】前記スロットルセンサ14は、エンジン1のスロットルチャンバ部に取り付けられたポテンシオメータ式センサで、スロットル開度TV0に応じた信号を出力する。

10 【0018】前記車速センサ16は、変速機出力軸位置に取付けられたパルスピックアップ式センサで、車速VSPに応じた信号を出力する。

【0019】前記ATモードスイッチ18は、パワー位置とオート位置とスノー位置との3位置切換スイッチで、パワー位置を選択した時にはシフトパターンとしてパワーパターンPPに固定され、オート位置を選択した時にはドライバーのアクセルワークに応じてエコノミーパターンEPとパワーパターンPPが自動的に切換制御され、スノー位置を選択した時には、シフトパターンとしてス

20 ノーパターンSPに固定される。  
【0020】前記コントロールユニット12のメモリには、そのシフトパターン記憶部に、図8に示すように通常走行に適するエコノミーパターンBPと、図9に示すようにパワフルな走行に適するパワーパターンPPと、雪路走行に適する図外のスノーパターンSPが記憶設定されている（シフトパターン設定手段に相当）。また、そのデータマップ記憶部に、図5に示すように、アクセル踏込速度 $\Delta TV0$ の基準切換判定データDa（100msecでのスロットル開度変化角度）をスロットル開度と車速に応じて設定した基準切換判定データマップM1と、図6に示すように、アクセル踏込速度 $\Delta TV0$ の補正データannmをスロットル開度と車速に応じて設定した補正データマップM2とが記憶設定されている。

【0021】作用を説明する。

30 【0022】図3は補正データマップM2の補正データannmを更新する処理作働の流れを示すフローチャートで（補正データ更新手段に相当）、以下、各ステップについて説明する。尚、この補正データ更新処理は、例えば、100msec毎の定時割り込み処理により行なわれ、ステアリング舵角 $\pm 10^\circ$ 以内や、所定車速以上の状態が所定時間以上継続している等の走行条件下で処理される。

40 【0023】ステップ50では、スロットル開度TV0が読み込まれる。

【0024】ステップ51では、車速VSPが読み込まれる。

【0025】ステップ52では、今回のスロットル開度TV0と前回のスロットル開度TV0Mの差の絶対値によりアクセル踏込速度 $\Delta TV0$ が演算される（アクセル踏込速度検出手段に相当）。

50 【0026】ステップ53では、今回のスロットル開度

TV0 が前回のスロットル開度TV0Mとしてメモリに記憶される。

【0027】ステップ54では、検出されたスロットル開度TV0 と車速VSP に応じた補正データ  $a_{nm}$  が図6に示す補正データマップM2から読み出される。

【0028】ステップ55では、1/4平均補正の手法により更新補正データ  $a_{nm}'$  が下記の式により演算される。

【0029】  $a_{nm}' = 3/4 a_{nm} + 1/4 \cdot \Delta TV0$  ステップ56では、更新補正データ  $a_{nm}'$  が補正データ  $a_{nm}$  として補正データマップM2に戻される。

【0030】以上の処理は、補正データ更新処理の走行条件を満足する間、繰り返し行なわれる。

【0031】図4はATモードスイッチ18のオート位置を選択している時に行なわれるシフトパターン切換制御のメインルーチンを示すフローチャートで、以下、各ステップについて説明する。

【0032】ステップ60では、図5に示す基準切換判定マップM1からスロットル開度TV0と車速VSP に応じた基準切換判定データDaが抜き出される（基準切換判定データ抜出手段に相当）。

【0033】ステップ61では、図6に示す補正データマップM2からスロットル開度TV0 と車速VSP に応じた補正データ  $a_{nm}$  が抜き出される（補正データ抜出手段に相当）。

【0034】ステップ62では、抜き出された基準切換判定データDaと補正データ  $a_{nm}$  を合算して切換判定値Dが演算される（切換判定値演算手段に相当）。尚、切換判定値Dをマップとしてあらわすと、図7に示すような切換判定値マップとなる。

【0035】ステップ63では、パワーパターンPPの選択時かどうか判断され、ステップ64では、アクセル踏込速度  $\Delta TV0$  が切換判定値Dを超えているかどうか判断され、エコノミーパターンEPが選択されている時で、 $\Delta TV0 > D$  を満足する時には、エコノミーパターンEPより高速段への変速時期を高車速側に遅らせたパワーパターンPPに切り換える指令が出力される（シフトパターン切換制御手段に相当）。

【0036】従って、例えば、高アクセル踏込速度によりアクセルワークを行なうドライバーの場合、図3に示す補正データ更新処理において、アクセル踏込速度  $\Delta TV0$  が大きな値となる為、 $a_{nm}' = 3/4 a_{nm} + 1/4 \cdot \Delta TV0$  により得られる更新補正データ  $a_{nm}'$  が次第に高い値となってゆき、学習結果によりそのドライバーのアクセルワークに適合した値が補正データ  $a_{nm}$  として補正データマップM2に設定されることになる。これにより、パワーパターンPPへの切換判定値Dは大きな値となり、アクセル踏込速度  $\Delta TV0$  を大きくしての平坦路走行時等ではエコノミーパターンEPが維持され、ドライバーの要求意思に合致したパワーパターンPPへの切換えタイミング

が得られる。

【0037】また、例えば、低アクセル踏込速度によりアクセルワークを行なうドライバーの場合、図3に示す補正データ更新処理において、アクセル踏込速度  $\Delta TV0$  が小さな値となる為、 $a_{nm}' = 3/4 a_{nm} + 1/4 \cdot \Delta TV0$  により得られる更新補正データ  $a_{nm}'$  が次第に低い値となってゆき、学習結果によりそのドライバーのアクセルワークに適合した値が補正データ  $a_{nm}$  として補正データマップM2に設定されることになる。これにより、パワーパターンPPへの切換判定値Dは小さな値となり、アクセル踏込速度  $\Delta TV0$  が十分に大きくない登坂時や追越し等であってもエコノミーパターンEPからパワーパターンPPへ容易に切り換えられ、ドライバーの要求意思に合致したパワーパターンPPへの切換えタイミングが得られる。

【0038】加えて、高アクセル踏込速度によりアクセルワークを行なうドライバーの場合でも低アクセル踏込速度によりアクセルワークを行なうドライバーの場合でも、ドライバーの個性が吸収されてパワーパターンPPへの切換頻度に一定性が保たれることになる。

【0039】以上説明してきたように、実施例にあっては、電子制御により2つ以上設定されているのシフトパターンをアクセルワークに基づいて自動的に切り換える自動変速機のシフトパターン切換制御装置において、ドライバーのアクセルワークの監視に基づく学習制御により補正データ  $a_{nm}$  を随時更新しながら作成し、アクセル踏込速度  $\Delta TV0$  の基準切換判定データDaをこの補正データ  $a_{nm}$  により補正してパワーパターンPPへの切換え制御を行なう装置とした為、ドライバーの個性の違いによりアクセルワークに個人差があっても各ドライバーの要求意思に合致したパワーパターンPPへの切換えタイミングを得ることができる。

【0040】以上、実施例を図面により説明してきたが、具体的な構成は実施例に限られるのではなく、本発明の要旨を逸脱しない範囲における変更や追加等があっても本発明に含まれる。

【0041】例えば、実施例では、エコノミーパターンからパワーパターンへ切り換える制御例を示したが、シフトパターンを3つ以上設定して、よりパワフルな走行が得られるパターンに切り換える場合にも適用することができる。

【0042】

【発明の効果】以上説明してきたように本発明にあっては、電子制御により2つ以上設定されているのシフトパターンをアクセルワークに基づいて自動的に切り換える自動変速機のシフトパターン切換制御装置において、ドライバーのアクセルワークの監視に基づく学習制御により補正データを随時更新しながら作成し、アクセル踏込速度の基準切換判定データをこの補正データにより補正してパワーパターンへの切換え制御を行なう手段とした

為、ドライバーの個性の違いによりアクセルワークに個人差があっても各ドライバーの要求意思に合致したパワーパターンへの切換えタイミングを得ることができるという効果が得られる。

【図面の簡単な説明】

【図1】実施例の自動変速機のシフトパターン切換制御装置を示すクレーム対応図である。

【図2】実施例のシフトパターン切換制御装置が適用された自動変速機の全体システム図である。

【図3】実施例装置のコントロールユニットで行なわれる補正データ更新処理作動の流れを示すフローチャートである。

【図4】実施例装置のコントロールユニットで行なわれるシフトパターン切換制御差動の流れを示すフローチャートである。

【図5】実施例装置での基準切換判定データマップを示す図である。

【図6】実施例装置での補正データマップを示す図である。

【図7】実施例装置での切換判定値をマップとしてあら

わした図である。

【図8】実施例装置のコントロールユニットにシフトパターンとして記憶設定されているエコノミーパターンを示す図である。

【図9】実施例装置のコントロールユニットにシフトパターンとして記憶設定されているパワーパターンを示す図である。

【符号の説明】

- a シフトパターン設定手段
- b スロットル開度検出手段
- c 車速検出手段
- d アクセル踏込速度検出手段
- e 基準切換判定データマップ
- f 補正データマップ
- g 補正データ更新手段
- h 基準切換判定データ抜出手段
- i 補正データ抜出手段
- j 切換判定値演算手段
- k シフトパターン切換制御手段

【図1】

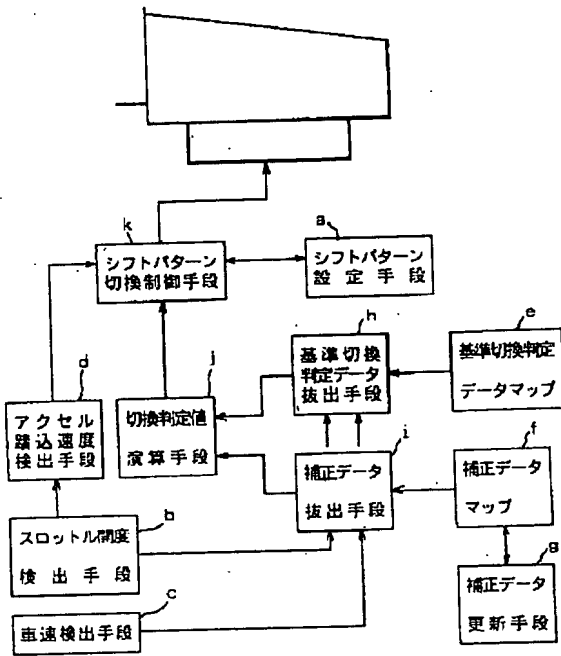

【図2】

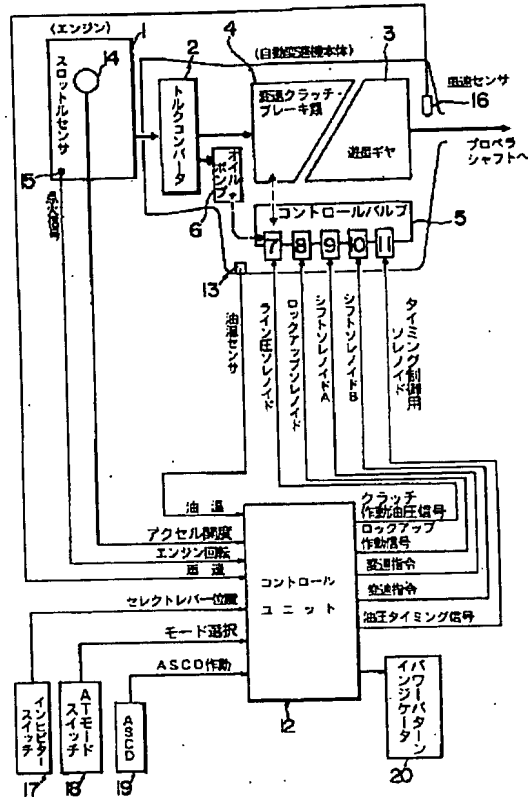

【図3】

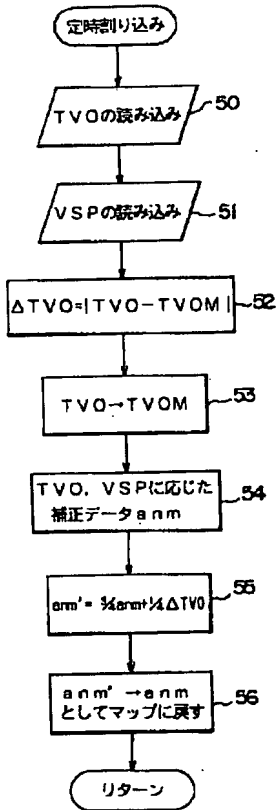

【図4】

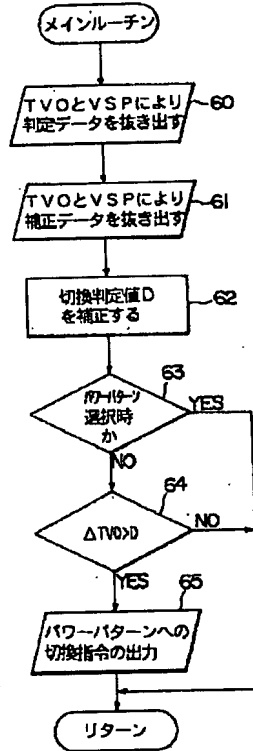

【図7】

【図5】

M1

5	6	7
10	12	13
17	20	25

大↑スロットル開度↑小  
低←車速→高

【図6】

M2

a <sub>11</sub>	a <sub>21</sub>	a <sub>31</sub>
a <sub>12</sub>	a <sub>22</sub>	a <sub>32</sub>
a <sub>13</sub>	a <sub>23</sub>	a <sub>33</sub>

大↑スロットル開度↑小  
低←車速→高

大↑スロットル開度↑小

5 + a <sub>11</sub>	6 + a <sub>21</sub>	7 + a <sub>31</sub>
10 + a <sub>12</sub>	12 + a <sub>22</sub>	13 + a <sub>32</sub>
17 + a <sub>13</sub>	20 + a <sub>23</sub>	25 + a <sub>33</sub>

低←車速→高

【図8】

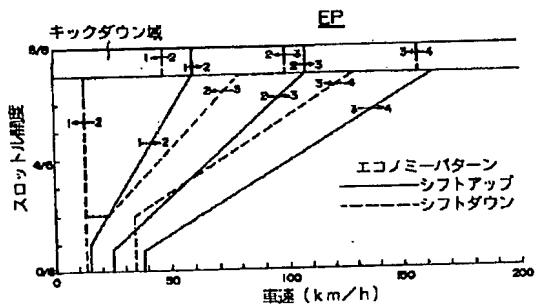

【図9】

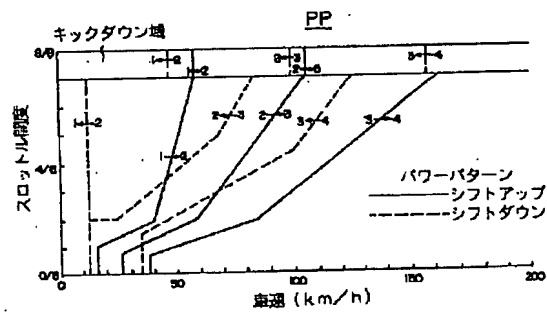



DFW

IN THE UNITED STATES PATENT AND TRADEMARK OFFICE

In re the Patent Application of :  
 :  
 Severinsky et al : Examiner: N/A  
 :  
 Serial No.: 11/429,457 : Group Art Unit: 3616  
 :  
 Filed: May 8, 2006 : Att.Dkt:PAICE201.DIV.3  
 :

For: Hybrid Vehicles

Hon. Commissioner for Patents  
 P.O. Box 1450  
 Alexandria VA 22313-1450

SUPPLEMENTAL INFORMATION DISCLOSURE STATEMENT

Listed on an accompanying PTO-1449 form are several new references which have recently come to the attention of the undersigned. The listed references all being US patents, no copies are being submitted. The Examiner is requested to consider these references and indicate that he has done so in the file of the application.

Respectfully submitted,

3/25/08

Dated:

Michael de Angeli  
 Reg. NO. 27,869  
 60 Intrepid Lane  
 Jamestown RI 02835  
 401-423-3190





NOTICE OF ALLOWANCE AND FEE(S) DUE

7590 09/05/2008

Michael de Angeli
60 Intrepid Lane
Jamestown, RI 02835

EXAMINER: COLLADO, CYNTHIA FRANCISCA
ART UNIT: 3618 PAPER NUMBER:
DATE MAILED: 09/05/2008

Table with 5 columns: APPLICATION NO., FILING DATE, FIRST NAMED INVENTOR, ATTORNEY DOCKET NO., CONFIRMATION NO.
Row 1: 11/429,457, 05/08/2006, Alex J. Severinsky, PAICE201.DIV.3, 1951
TITLE OF INVENTION: HYBRID VEHICLES

Table with 7 columns: APPLN. TYPE, SMALL ENTITY, ISSUE FEE DUE, PUBLICATION FEE DUE, PREV. PAID ISSUE FEE, TOTAL FEE(S) DUE, DATE DUE
Row 1: nonprovisional, NO, \$1440, \$300, \$0, \$1740, 12/05/2008

THE APPLICATION IDENTIFIED ABOVE HAS BEEN EXAMINED AND IS ALLOWED FOR ISSUANCE AS A PATENT. PROSECUTION ON THE MERITS IS CLOSED. THIS NOTICE OF ALLOWANCE IS NOT A GRANT OF PATENT RIGHTS. THIS APPLICATION IS SUBJECT TO WITHDRAWAL FROM ISSUE AT THE INITIATIVE OF THE OFFICE OR UPON PETITION BY THE APPLICANT. SEE 37 CFR 1.313 AND MPEP 1308.

THE ISSUE FEE AND PUBLICATION FEE (IF REQUIRED) MUST BE PAID WITHIN THREE MONTHS FROM THE MAILING DATE OF THIS NOTICE OR THIS APPLICATION SHALL BE REGARDED AS ABANDONED. THIS STATUTORY PERIOD CANNOT BE EXTENDED. SEE 35 U.S.C. 151. THE ISSUE FEE DUE INDICATED ABOVE DOES NOT REFLECT A CREDIT FOR ANY PREVIOUSLY PAID ISSUE FEE IN THIS APPLICATION. IF AN ISSUE FEE HAS PREVIOUSLY BEEN PAID IN THIS APPLICATION (AS SHOWN ABOVE), THE RETURN OF PART B OF THIS FORM WILL BE CONSIDERED A REQUEST TO REAPPLY THE PREVIOUSLY PAID ISSUE FEE TOWARD THE ISSUE FEE NOW DUE.

HOW TO REPLY TO THIS NOTICE:

I. Review the SMALL ENTITY status shown above.

If the SMALL ENTITY is shown as YES, verify your current SMALL ENTITY status:

- A. If the status is the same, pay the TOTAL FEE(S) DUE shown above.
B. If the status above is to be removed, check box 5b on Part B - Fee(s) Transmittal and pay the PUBLICATION FEE (if required) and twice the amount of the ISSUE FEE shown above, or

If the SMALL ENTITY is shown as NO:

- A. Pay TOTAL FEE(S) DUE shown above, or
B. If applicant claimed SMALL ENTITY status before, or is now claiming SMALL ENTITY status, check box 5a on Part B - Fee(s) Transmittal and pay the PUBLICATION FEE (if required) and 1/2 the ISSUE FEE shown above.

II. PART B - FEE(S) TRANSMITTAL, or its equivalent, must be completed and returned to the United States Patent and Trademark Office (USPTO) with your ISSUE FEE and PUBLICATION FEE (if required). If you are charging the fee(s) to your deposit account, section "4b" of Part B - Fee(s) Transmittal should be completed and an extra copy of the form should be submitted. If an equivalent of Part B is filed, a request to reapply a previously paid issue fee must be clearly made, and delays in processing may occur due to the difficulty in recognizing the paper as an equivalent of Part B.

III. All communications regarding this application must give the application number. Please direct all communications prior to issuance to Mail Stop ISSUE FEE unless advised to the contrary.

IMPORTANT REMINDER: Utility patents issuing on applications filed on or after Dec. 12, 1980 may require payment of maintenance fees. It is patentee's responsibility to ensure timely payment of maintenance fees when due.

**PART B - FEE(S) TRANSMITTAL**

**Complete and send this form, together with applicable fee(s), to: Mail Mail Stop ISSUE FEE  
 Commissioner for Patents  
 P.O. Box 1450  
 Alexandria, Virginia 22313-1450  
 or Fax (571)-273-2885**

**INSTRUCTIONS:** This form should be used for transmitting the ISSUE FEE and PUBLICATION FEE (if required). Blocks 1 through 5 should be completed where appropriate. All further correspondence including the Patent, advance orders and notification of maintenance fees will be mailed to the current correspondence address as indicated unless corrected below or directed otherwise in Block 1, by (a) specifying a new correspondence address; and/or (b) indicating a separate "FEE ADDRESS" for maintenance fee notifications.

CURRENT CORRESPONDENCE ADDRESS (Note: Use Block 1 for any change of address)

7590 09/05/2008

Michael de Angeli  
 60 Intrepid Lane  
 Jamestown, RI 02835

Note: A certificate of mailing can only be used for domestic mailings of the Fee(s) Transmittal. This certificate cannot be used for any other accompanying papers. Each additional paper, such as an assignment or formal drawing, must have its own certificate of mailing or transmission.

**Certificate of Mailing or Transmission**

I hereby certify that this Fee(s) Transmittal is being deposited with the United States Postal Service with sufficient postage for first class mail in an envelope addressed to the Mail Stop ISSUE FEE address above, or being facsimile transmitted to the USPTO (571) 273-2885, on the date indicated below.

(Depositor's name)
(Signature)
(Date)

APPLICATION NO.	FILING DATE	FIRST NAMED INVENTOR	ATTORNEY DOCKET NO.	CONFIRMATION NO.
-----------------	-------------	----------------------	---------------------	------------------

11/429,457      05/08/2006      Alex J. Severinsky      PAICE201.DIV.3      1951

TITLE OF INVENTION: HYBRID VEHICLES

APPLN. TYPE	SMALL ENTITY	ISSUE FEE DUE	PUBLICATION FEE DUE	PREV. PAID ISSUE FEE	TOTAL FEE(S) DUE	DATE DUE
-------------	--------------	---------------	---------------------	----------------------	------------------	----------

nonprovisional      NO      \$1440      \$300      \$0      \$1740      12/05/2008

EXAMINER	ART UNIT	CLASS-SUBCLASS
----------	----------	----------------

COLLADO, CYNTHIA FRANCISCA      3618      180-065200

1. Change of correspondence address or indication of "Fee Address" (37 CFR 1.363).

- Change of correspondence address (or Change of Correspondence Address form PTO/SB/122) attached.
- "Fee Address" indication (or "Fee Address" Indication form PTO/SB/47; Rev 03-02 or more recent) attached. **Use of a Customer Number is required.**

2. For printing on the patent front page, list

- (1) the names of up to 3 registered patent attorneys or agents OR, alternatively, 1 \_\_\_\_\_
- (2) the name of a single firm (having as a member a registered attorney or agent) and the names of up to 2 registered patent attorneys or agents. If no name is listed, no name will be printed. 2 \_\_\_\_\_
- 3 \_\_\_\_\_

3. ASSIGNEE NAME AND RESIDENCE DATA TO BE PRINTED ON THE PATENT (print or type)

PLEASE NOTE: Unless an assignee is identified below, no assignee data will appear on the patent. If an assignee is identified below, the document has been filed for recordation as set forth in 37 CFR 3.11. Completion of this form is NOT a substitute for filing an assignment.

(A) NAME OF ASSIGNEE      (B) RESIDENCE: (CITY AND STATE OR COUNTRY)

Please check the appropriate assignee category or categories (will not be printed on the patent) :     Individual     Corporation or other private group entity     Government

4a. The following fee(s) are submitted:

- Issue Fee
- Publication Fee (No small entity discount permitted)
- Advance Order - # of Copies \_\_\_\_\_

4b. Payment of Fee(s); (Please first reapply any previously paid issue fee shown above)

- A check is enclosed.
- Payment by credit card. Form PTO-2038 is attached.
- The Director is hereby authorized to charge the required fee(s), any deficiency, or credit any overpayment, to Deposit Account Number \_\_\_\_\_ (enclose an extra copy of this form).

5. Change in Entity Status (from status indicated above)

- a. Applicant claims SMALL ENTITY status. See 37 CFR 1.27.       b. Applicant is no longer claiming SMALL ENTITY status. See 37 CFR 1.27(g)(2).

NOTE: The Issue Fee and Publication Fee (if required) will not be accepted from anyone other than the applicant; a registered attorney or agent; or the assignee or other party in interest as shown by the records of the United States Patent and Trademark Office.

Authorized Signature \_\_\_\_\_ Date \_\_\_\_\_

Typed or printed name \_\_\_\_\_ Registration No. \_\_\_\_\_

This collection of information is required by 37 CFR 1.311. The information is required to obtain or retain a benefit by the public which is to file (and by the USPTO to process) an application. Confidentiality is governed by 35 U.S.C. 122 and 37 CFR 1.14. This collection is estimated to take 12 minutes to complete, including gathering, preparing, and submitting the completed application form to the USPTO. Time will vary depending upon the individual case. Any comments on the amount of time you require to complete this form and/or suggestions for reducing this burden, should be sent to the Chief Information Officer, U.S. Patent and Trademark Office, U.S. Department of Commerce, P.O. Box 1450, Alexandria, Virginia 22313-1450. DO NOT SEND FEES OR COMPLETED FORMS TO THIS ADDRESS. SEND TO: Commissioner for Patents, P.O. Box 1450, Alexandria, Virginia 22313-1450.

Under the Paperwork Reduction Act of 1995, no persons are required to respond to a collection of information unless it displays a valid OMB control number.





UNITED STATES PATENT AND TRADEMARK OFFICE

UNITED STATES DEPARTMENT OF COMMERCE
United States Patent and Trademark Office
Address: COMMISSIONER FOR PATENTS
P. O. Box 1450
Alexandria, Virginia 22313-1450
www.uspto.gov

Table with columns: APPLICATION NO., FILING DATE, FIRST NAMED INVENTOR, ATTORNEY DOCKET NO., CONFIRMATION NO., EXAMINER, COLLADO, CYNTHIA FRANCISCA, ART UNIT, PAPER NUMBER, DATE MAILED: 09/05/2008

Determination of Patent Term Adjustment under 35 U.S.C. 154 (b)
(application filed on or after May 29, 2000)

The Patent Term Adjustment to date is 425 day(s). If the issue fee is paid on the date that is three months after the mailing date of this notice and the patent issues on the Tuesday before the date that is 28 weeks (six and a half months) after the mailing date of this notice, the Patent Term Adjustment will be 425 day(s).

If a Continued Prosecution Application (CPA) was filed in the above-identified application, the filing date that determines Patent Term Adjustment is the filing date of the most recent CPA.

Applicant will be able to obtain more detailed information by accessing the Patent Application Information Retrieval (PAIR) WEB site (http://pair.uspto.gov).

Any questions regarding the Patent Term Extension or Adjustment determination should be directed to the Office of Patent Legal Administration at (571)-272-7702. Questions relating to issue and publication fee payments should be directed to the Customer Service Center of the Office of Patent Publication at 1-(888)-786-0101 or (571)-272-4200.

**Notice of Allowability**

<b>Application No.</b> 11/429,457	<b>Applicant(s)</b> SEVERINSKY ET AL.	
<b>Examiner</b> CYNTHIA F. COLLADO	<b>Art Unit</b> 3618	

**-- The MAILING DATE of this communication appears on the cover sheet with the correspondence address--**

All claims being allowable, PROSECUTION ON THE MERITS IS (OR REMAINS) CLOSED in this application. If not included herewith (or previously mailed), a Notice of Allowance (PTOL-85) or other appropriate communication will be mailed in due course. **THIS NOTICE OF ALLOWABILITY IS NOT A GRANT OF PATENT RIGHTS.** This application is subject to withdrawal from issue at the initiative of the Office or upon petition by the applicant. See 37 CFR 1.313 and MPEP 1308.

- 1.  This communication is responsive to 5/8/2008.
- 2.  The allowed claim(s) is/are 17-78.
- 3.  Acknowledgment is made of a claim for foreign priority under 35 U.S.C. § 119(a)-(d) or (f).
  - a)  All   b)  Some\*   c)  None   of the:
    - 1.  Certified copies of the priority documents have been received.
    - 2.  Certified copies of the priority documents have been received in Application No. \_\_\_\_\_.
    - 3.  Copies of the certified copies of the priority documents have been received in this national stage application from the International Bureau (PCT Rule 17.2(a)).

\* Certified copies not received: \_\_\_\_\_.

Applicant has THREE MONTHS FROM THE "MAILING DATE" of this communication to file a reply complying with the requirements noted below. Failure to timely comply will result in ABANDONMENT of this application.

**THIS THREE-MONTH PERIOD IS NOT EXTENDABLE.**

- 4.  A SUBSTITUTE OATH OR DECLARATION must be submitted. Note the attached EXAMINER'S AMENDMENT or NOTICE OF INFORMAL PATENT APPLICATION (PTO-152) which gives reason(s) why the oath or declaration is deficient.
  - 5.  CORRECTED DRAWINGS ( as "replacement sheets") must be submitted.
    - (a)  including changes required by the Notice of Draftsperson's Patent Drawing Review ( PTO-948) attached
      - 1)  hereto or 2)  to Paper No./Mail Date \_\_\_\_\_.
    - (b)  including changes required by the attached Examiner's Amendment / Comment or in the Office action of Paper No./Mail Date \_\_\_\_\_.
- Identifying indicia such as the application number (see 37 CFR 1.84(c)) should be written on the drawings in the front (not the back) of each sheet. Replacement sheet(s) should be labeled as such in the header according to 37 CFR 1.121(d).**
- 6.  DEPOSIT OF and/or INFORMATION about the deposit of BIOLOGICAL MATERIAL must be submitted. Note the attached Examiner's comment regarding REQUIREMENT FOR THE DEPOSIT OF BIOLOGICAL MATERIAL.

**Attachment(s)**

- 1.  Notice of References Cited (PTO-892)
- 2.  Notice of Draftsperson's Patent Drawing Review (PTO-948)
- 3.  Information Disclosure Statements (PTO/SB/08),  
Paper No./Mail Date 8/22/2007, 7/7/2006, 03/28/2008
- 4.  Examiner's Comment Regarding Requirement for Deposit of Biological Material
- 5.  Notice of Informal Patent Application
- 6.  Interview Summary (PTO-413),  
Paper No./Mail Date \_\_\_\_\_.
- 7.  Examiner's Amendment/Comment
- 8.  Examiner's Statement of Reasons for Allowance
- 9.  Other \_\_\_\_\_.

/Christopher P Ellis/  
Supervisory Patent Examiner, Art Unit 3618



<b>Notice of References Cited</b>	Application/Control No. 11/429,457	Applicant(s)/Patent Under Reexamination SEVERINSKY ET AL.	
	Examiner CYNTHIA F. COLLADO	Art Unit 3618	Page 1 of 1

**U.S. PATENT DOCUMENTS**

*		Document Number Country Code-Number-Kind Code	Date MM-YYYY	Name	Classification
*	A	US-6,592,484	07-2003	Tsai et al.	475/5
*	B	US-6,563,230	05-2003	Nada, Mitsuhiro	290/40C
*	C	US-6,481,516	11-2002	Field et al.	180/65.2
*	D	US-6,470,983	10-2002	Amano et al.	180/65.2
*	E	US-6,344,008	02-2002	Nagano et al.	475/1
*	F	US-6,328,670	12-2001	Minowa et al.	477/5
*	G	US-6,306,057	10-2001	Morisawa et al.	475/5
	H	US-			
	I	US-			
	J	US-			
	K	US-			
	L	US-			
	M	US-			

**FOREIGN PATENT DOCUMENTS**

*		Document Number Country Code-Number-Kind Code	Date MM-YYYY	Country	Name	Classification
	N					
	O					
	P					
	Q					
	R					
	S					
	T					

**NON-PATENT DOCUMENTS**

*		Include as applicable: Author, Title Date, Publisher, Edition or Volume, Pertinent Pages)
	U	
	V	
	W	
	X	

\*A copy of this reference is not being furnished with this Office action. (See MPEP § 707.05(a).)  
Dates in MM-YYYY format are publication dates. Classifications may be US or foreign.

<b>Application Number</b> 	<b>Application/Control No.</b> 11/429,457	<b>Applicant(s)/Patent under Reexamination</b> SEVERINSKY ET AL.	
	<b>Examiner</b> CYNTHIA F. COLLADO	<b>Art Unit</b> 3618	

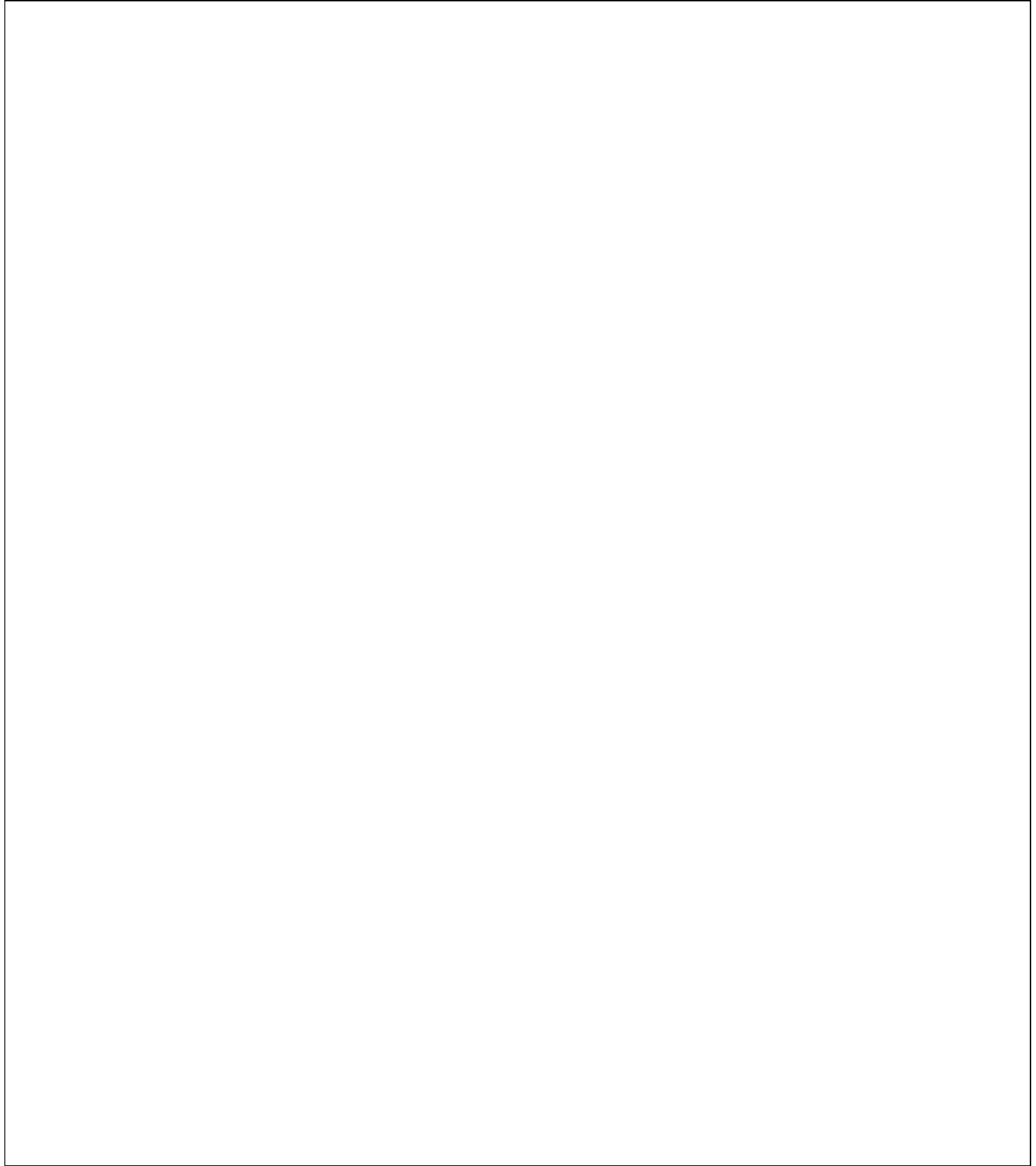

**Index of Claims**



Application/Control No.

11/429,457

Examiner

CYNTHIA F. COLLADO

Applicant(s)/Patent under Reexamination

SEVERINSKY ET AL.

Art Unit

3618

√	Rejected
=	Allowed

—	(Through numeral) Cancelled
÷	Restricted

N	Non-Elected
I	Interference

A	Appeal
O	Objected

Claim		Date									
Final	Original	8/26/08									
	1	-									
	2	-									
	3	-									
	4	-									
	5	-									
	6	-									
	7	-									
	8	-									
	9	-									
	10	-									
	11	-									
	12	-									
	13	-									
	14	-									
	15	-									
1	17	=									
2	18	=									
3	19	=									
4	20	=									
5	21	=									
6	22	=									
7	23	=									
8	24	=									
9	25	=									
10	26	=									
11	27	=									
12	28	=									
13	29	=									
14	30	=									
15	31	=									
16	32	=									
17	33	=									
18	34	=									
19	35	=									
20	36	=									
21	37	=									
22	38	=									
23	39	=									
24	40	=									
25	41	=									
26	42	=									
27	43	=									
28	44	=									
29	45	=									
30	46	=									
31	47	=									
32	48	=									
33	49	=									
34	50	=									

Claim		Date									
Final	Original										
35	51	=									
36	52	=									
37	53	=									
38	54	=									
39	55	=									
40	56	=									
41	57	=									
42	58	=									
43	59	=									
44	60	=									
45	61	=									
46	62	=									
47	63	=									
48	64	=									
49	65	=									
50	66	=									
51	67	=									
52	68	=									
53	69	=									
54	70	=									
55	71	=									
56	72	=									
57	73	=									
58	74	=									
59	75	=									
60	76	=									
61	77	=									
62	78	=									
	79										
	80										
	81										
	82										
	83										
	84										
	85										
	86										
	87										
	88										
	89										
	90										
	91										
	92										
	93										
	94										
	95										
	96										
	97										
	98										
	99										
	100										

Claim		Date									
Final	Original										
	101										
	102										
	103										
	104										
	105										
	106										
	107										
	108										
	109										
	110										
	111										
	112										
	113										
	114										
	115										
	116										
	117										
	118										
	119										
	120										
	121										
	122										
	123										
	124										
	125										
	126										
	127										
	128										
	129										
	130										
	131										
	132										
	133										
	134										
	135										
	136										
	137										
	138										
	139										
	140										
	141										
	142										
	143										
	144										
	145										
	146										
	147										
	148										
	149										
	150										

<b>Issue Classification</b> 	<b>Application/Control No.</b> 11/429,457	<b>Applicant(s)/Patent under Reexamination</b> SEVERINSKY ET AL.	
	<b>Examiner</b> CYNTHIA F. COLLADO	<b>Art Unit</b> 3618	

ISSUE CLASSIFICATION										
ORIGINAL				CROSS REFERENCE(S)						
CLASS		SUBCLASS		CLASS	SUBCLASS (ONE SUBCLASS PER BLOCK)					
180		65.2		180	65.4	205	65.1	65.8	65.7	701
INTERNATIONAL CLASSIFICATION				701	54					
B	6	0	K	6/00						
				/						
				/						
				/						
				/						

Cynthia F. Collado (Assistant Examiner) (Date)	/Christopher Ellis/ 8/27/08 (Primary Examiner) (Date)	<b>Total Claims Allowed: 62</b>
(Legal Instruments Examiner) (Date)		O.G. Print Claim(s)      O.G. Print Fig. 1                                      1

<input type="checkbox"/> Claims renumbered in the same order as presented by applicant		<input type="checkbox"/> CPA		<input type="checkbox"/> T.D.		<input type="checkbox"/> R.1.47	
Final	Original	Final	Original	Final	Original	Final	Original
	1	15	31	45	61		91
	2	16	32	46	62		92
	3	17	33	47	63		93
	4	18	34	48	64		94
	5	19	35	49	65		95
	6	20	36	50	66		96
	7	21	37	51	67		97
	8	22	38	52	68		98
	9	23	39	53	69		99
	10	24	40	54	70		100
	11	25	41	55	71		101
	12	26	42	56	72		102
	13	27	43	57	73		103
	14	28	44	58	74		104
	15	29	45	59	75		105
	16	30	46	60	76		106
1	17	31	47	61	77		107
2	18	32	48	62	78		108
3	19	33	49		79		109
4	20	34	50		80		110
5	21	35	51		81		111
6	22	36	52		82		112
7	23	37	53		83		113
8	24	38	54		84		114
9	25	39	55		85		115
10	26	40	56		86		116
11	27	41	57		87		117
12	28	42	58		88		118
13	29	43	59		89		119
14	30	44	60		90		120
							121
							122
							123
							124
							125
							126
							127
							128
							129
							130
							131
							132
							133
							134
							135
							136
							137
							138
							139
							140
							141
							142
							143
							144
							145
							146
							147
							148
							149
							150
							151
							152
							153
							154
							155
							156
							157
							158
							159
							160
							161
							162
							163
							164
							165
							166
							167
							168
							169
							170
							171
							172
							173
							174
							175
							176
							177
							178
							179
							180
							181
							182
							183
							184
							185
							186
							187
							188
							189
							190
							191
							192
							193
							194
							195
							196
							197
							198
							199
							200
							201
							202
							203
							204
							205
							206
							207
							208
							209
							210







IFW



IN THE UNITED STATES PATENT AND TRADEMARK OFFICE

re the Patent Application of :

Severinsky et al	:	Examiner: N/A
Serial No.: 11/429,457	:	Group Art Unit: 3616
Filed: May 8, 2006	:	Att.Dkt:PAICE201.DIV.3
For: Hybrid Vehicles	:	

Hon. Commissioner for Patents  
P.O. Box 1450  
Alexandria VA 22313-1450

INFORMATION DISCLOSURE STATEMENT

Sir:

This application is a divisional of Ser. No. 10/382,577. Incorporated herein by reference are the several Information Disclosure Statements (IDSs) that were filed in Ser. No. 10/382,577, and its predecessor, Ser. No. 09/822,866, now Patent 6,554,088. Copies of the IDSs thus incorporated are attached, together with the corresponding PTO-1449 forms. Where available the PTO-1449s attached are those returned by the Examiner, showing corrections that were noted in prosecution of the earlier applications. Copies of the documents thus cited were supplied in the parent and grandparent applications, or in earlier predecessor applications Ser. Nos. 09/264,817, now patent 6,209,672, and 09/392,743, now patent 6,338,391, and copies are accordingly not now being supplied herewith.

The Examiner is respectfully requested to consider the documents thus made of record, and to initial the PTO-1449 forms, indicating that he has done so.

Should there be any questions, the Examiner is invited to telephone the undersigned at the number given below.

Early and favorable action on the merits is earnestly solicited.

July 6, 2006  
Dated:

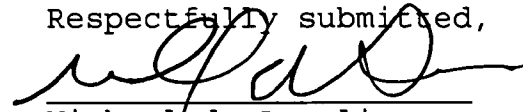
Respectfully submitted,  
  
Michael de Angeli  
Reg. No. 27,869  
60 Intrepid Lane  
Jamestown RI 02835  
401-423-3190



IN THE UNITED STATES PATENT AND TRADEMARK OFFICE

In re the Patent Application of	:	
Severinsky et al	:	Examiner: David Dunn
Serial No.: 10/382,577	:	Group Art Unit: 3616
Filed: March 7, 2003	:	Att.Dkt.: PAICE201.DIV
For: Hybrid Vehicles	:	

Hon. Commissioner for Patents  
P.O. Box 1450  
Alexandria VA 22313-1450

**FOURTH SUPPLEMENTAL INFORMATION DISCLOSURE STATEMENT**

Sir:

Applicant submits this Information Disclosure Statement for consideration by the Examiner. The issued patents from which this application claims priority have been asserted against Toyota Motor Corporation, Toyota Motor North America, Inc. and Toyota Motor Sales, USA, Inc. (collectively "Toyota") in civil action 2:04-CV-211 in the United States District Court for the Eastern District of Texas. A jury trial was recently conducted December 6-20, 2005, and a verdict holding the parent patents as valid but not infringed was returned.

Applicants submit herewith materials from this litigation for the purpose of full disclosure. Applicants respectfully request the Examiner to fully review and consider these materials in determining patentability of the present application. The materials submitted include transcripts of the trial and deposition testimony of the witnesses on whom Toyota relied for prior art assertions, with any confidential material redacted therefrom, together with copies of the documentary evidence discussed therein.

The materials also include a copy of the Court's Markman ruling construing the claims of the parent patents.

The Examiner is respectfully requested to consider these materials and indicate that he has done so in the file of this application.

Should the Examiner have any questions concerning the materials submitted, he is invited to telephone the undersigned at the number given below.

A Supplemental Notice of Allowability is earnestly solicited.

March 27, 2006  
Dated:

Respectfully submitted,



Michael De Angeli  
Reg. No. 27,869  
60 Intrepid Lane  
Jamestown, RI 02835  
401-423-3190



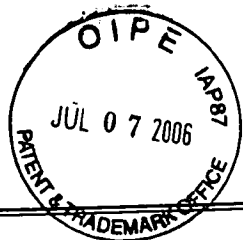

INFORMATION DISCLOSURE CITATION IN AN APPLICATION	DOCKET NUMBER	PAICE201.DIV	APPLICATION NUMBER	10/382,577
	APPLICANT			
	Severinsky et al			
FILING DATE		3/7/2003	GROUP ART UNIT	
			361	

**U. S. PATENT DOCUMENTS**

EXAMINER INITIAL	DOCUMENT NUMBER	DATE	NAME	CLASS	SUBCLAS	FILING DATE	
	5 2 5 3 9 2 9	10/1993	Ohuri				
	5 3 2 6 1 5 8	7/1994	Ohuri				
	5 4 7 6 1 5 1	12/1995	Tsuchida et al				
	5 5 6 9 9 9 5	10/1996	Kusaka et al				
	5 6 3 7 9 7 7	6/1997	Saito et al				
	5 7 8 9 9 3 5	8/1998	Suga et al				
	5 8 9 5 1 0 0	4/1999	Ito et al				
	5 9 5 1 1 1 5	9/1999	Sakai et al				
	5 9 7 3 4 6 3	10/1999	Okuda et al				
	6 0 5 3 8 4 1	4/2000	Koide et al				
	5 9 2 9 5 9 4	7/1999	Nonobe et al				
	5 9 2 4 3 9 5	7/1999	Moriya et al				

**FOREIGN PATENT DOCUMENTS**

DOCUMENT NUMBER	DATE	COUNTRY	CLASS	SUBCLASS	TRANSLATION	
					YES	NO
0 1 3 6 0 5 5	03.04.85	European Patent Office				

**OTHER DOCUMENTS** (Including Author, Title, Date, Pertinent Pages, Etc)

	Miller et al, "Starter-Alternator for Hybrid Electric Vehicle.." (1996)
	Johnston et al, "The Design and Development of the [UC Davis].." (No date)
	Johnston et al, "The Design and Development of the [UC Davis].." (1997)
	Alexander et al, "A Mid-Sized Sedan Designed for High Fuel..." (No date)
	"PRIUS New Car Features", (Toyota manual) (1998)
	TRW Systems Group, "Analysis and Advanced Design Study..." (1971)

EXAMINER /Cynthia Collado/ (08/26/2008) DATE CONSIDERED 08/26/2008

EXAMINER: Initial if citation considered, whether or not citation is in conformance with MPEP §609; Draw line through citation if not in conformance and not considered. Include copy of this form with next communication to the applicant.











<b>INFORMATION DISCLOSURE CITATION IN AN APPLICATION</b>	DOCKET NUMBER	PAICE201.DIV	APPLICATION NUMBER	10/382,577
	APPLICANT			
	Severinsky et al			
FILING DATE		3/7/2003	GROUP ART UNIT	
			361	

**U. S. PATENT DOCUMENTS**

EXAMINER INITIAL	DOCUMENT NUMBER	DATE	NAME	CLASS	SUBCLAS	FILING DATE

**FOREIGN PATENT DOCUMENTS**

DOCUMENT NUMBER	DATE	COUNTRY	CLASS	SUBCLASS	TRANSLATION	
					YES	NO

**OTHER DOCUMENTS** (Including Author, Title, Date, Pertinent Pages, Etc)

	North American Technology Seminar plans, April 1997
	Hermance, THS Technical Explanation (undated)
	"Toyota" brochure describing Prius (undated)
	Hermance, "Toyota Hybrid System" (undated)

EXAMINER /Cynthia Collado/ (08/26/2008)	DATE CONSIDERED 08/26/2008
---	----------------------------

EXAMINER: Initial if citation considered, whether or not citation is in conformance with MPEP §609; Draw line through citation if not in conformance and not considered. Include copy of this form with next communication to the applicant.

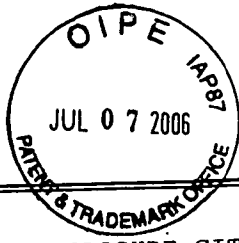

INFORMATION DISCLOSURE CITATION IN AN APPLICATION	DOCKET NUMBER	PAICE201.DIV	APPLICATION NUMBER	10/382,577
	APPLICANT			
	FILING DATE	3/7/2003	GROUP ART UNIT	361

**U. S. PATENT DOCUMENTS**

EXAMINER INITIAL	DOCUMENT NUMBER						DATE	NAME	CLASS	SUBCLAS	FILING DATE	
	5	4	1	2	2	9	3	5/1995				Minesawa et al
	5	8	8	3	4	8	4	3/1999				Akao

**FOREIGN PATENT DOCUMENTS**

DOCUMENT NUMBER	DATE	COUNTRY	CLASS	SUBCLASS	TRANSLATION	
					YES	NO
8 2 1 4 5 9 2	8.20.1996	Japan			abs t.	
1 0 6 6 3 8 3	3.6.1998	Japan			abs t.	

**OTHER DOCUMENTS** (Including Author, Title, Date, Pertinent Pages, Etc)

	Cuddy et al, "Analysis of the Fuel Economy Benefit..." SAE 970289 (1997)
	"Team Paradigm Shines in FutureCar Competition" (1996)
	Takaoka et al, "Study of the Engine Optimized for Hybrid System" (undated)
	Gelb et al, "Cost and Emission Studies of a Heat Engine/Battery.." (1972)
	Gelb et al, "Design and Performance Characteristics..." SAE 690169 (1969)
	"Electric/Hybrid Vehicles: Alternative Powerplants..." SAE SP-1284 (1997)

EXAMINER	/Cynthia Collado/ (08/26/2008)	DATE CONSIDERED	08/26/2008
----------	--------------------------------	-----------------	------------

EXAMINER: Initial if citation considered, whether or not citation is in conformance with MPEP §609; Draw line through citation if not in conformance and not considered. Include copy of this form with next communication to the applicant.



IN THE UNITED STATES PATENT AND TRADEMARK OFFICE

In re the Patent Application of :  
Severinsky et al : Examiner: David Dunn  
Serial No.: 10/382,577 : Group Art Unit: 3616  
Filed: March 7, 2003 : Att.Dkt.: PAICE201.DIV  
For: Hybrid Vehicles :  
Hon. Commissioner for Patents  
P.O. Box 1450  
Alexandria VA 22313-1450

**SUPPLEMENTAL INFORMATION DISCLOSURE STATEMENT**

Sir:

The issued patents from which this application claims priority are being asserted against an alleged infringer in civil litigation in the United States District Court for the Eastern District of Texas. The defendants in that case have brought a number of new patents and other documents to applicants' attention. New documents have also been cited in a Complete Search Report prepared by the European Patent Office, dated May 5, 2005 (copy enclosed) against a European application claiming priority from the same US applications. These newly-cited patents and other documents thus located are listed on attached PTO-1449 forms, and are discussed below. The Examiner is respectfully requested to consider these new documents and to indicate that he has done so in the file of this application, and to then re-issue the Notice of Allowance mailed April 21, 2005.

Citation of a document herein should not be considered an admission that the disclosure thereof is indeed relevant to the invention defined by the claims, nor

that the document thus made of record is indeed effective as prior art under 35 USC 102.

It is respectfully submitted that although this Statement is being filed after issue of a Notice of Allowance, it is timely under 37 CFR 1.97 (e). The fee of \$180.00 (per 37 CFR 1.17(p)) is enclosed.

It is respectfully submitted that none of the newly-cited patents or other documents made of record hereby disclose or suggest the invention claimed herein. Early and favorable action on the merits of the application - specifically, issue of the patent, the Issue Fee having been paid concurrently with submission of this Statement - is earnestly solicited.

Dated:

6/30/05

Respectfully submitted,

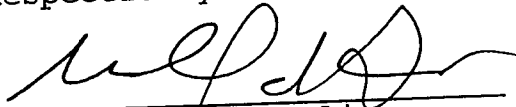

Michael de Angeli  
Reg. No. 27,869  
60 Intrepid Lane  
Jamestown, RI 02835  
401-423-3190



115

<b>INFORMATION DISCLOSURE CITATION IN AN APPLICATION</b>	DOCKET NUMBER	PAICE201.DIV	APPLICATION NUMBER	10/382,577
	APPLICANT			
	Severinsky et al			
FILING DATE		3/7/2003	GROUP ART UNIT	3616

**U. S. PATENT DOCUMENTS**

EXAMINER INITIAL	DOCUMENT NUMBER	DATE	NAME	CLASS	SUBCLAS	FILING DATE	
DD	5 8 4 4 3 4 2	12/1998	Miyatani et al				
DD	5 8 0 4 9 4 7	9/1998	Nii et al				
DD	5 4 5 7 3 6 3	10/1995	Yoshii et al				
DD	5 9 0 7 1 9 1	5/1999	Sasaki et al				
DD	5 9 1 4 5 7 5	6/1999	Sasaki				
DD	6 0 0 5 2 9 7	12/1999	Sasaki et al				
DD	6 1 6 6 4 9 9	12/2000	Kanamori et al				
DD	5 8 0 1 4 9 7	9/1998	Shamoto et al				
DD	5 9 0 9 7 2 0	6/1999	Yamaoka				
DD	5 6 9 8 9 5 5	12/1997	Nii				
DD	5 4 2 8 2 7 4	6/1995	Furutani et al				
DD	6 0 7 7 1 8 6	6/2000	Kojima et al				

**FOREIGN PATENT DOCUMENTS**

	DOCUMENT NUMBER	DATE	COUNTRY	CLASS	SUBCLASS	TRANSLATION	
						YES	NO
DD	2 4 1 9 8 3 2	3/1978	France			X	
DD	3 1 2 4 2 0 1	10/1989	Japan			X	
DD	51 1 0 3 2 2 0	2/1975	Japan			X	
DD	H5 6 4 5 3 1	9/1984	Japan			X	
DD	S 48 4 9 1 1 5	10/1971	Japan			X	

**OTHER DOCUMENTS (Including Author, Title, Date, Pertinent Pages, Etc)**

DD	Winkelman et al, SAE paper 730511, "Computer Simulation...." (1973)
DD	Berman et al, IEEE VT-23, NO. 3, pp. 61-72 "Propulsion Systems...." (1974)
DD	Berman SPC-TUE-2 "Battery Powered Regenerative SCR Drive" (1970)
DD	Gelb et al "Performance Analyses..." ACS pub (1972), pp 977-988
DD	Berman SPC-TUE-1 "Design Considerations...." (1971)
DD	Berman SPC-TUE-2 "All Solid State Method...." (1971)

/Cynthia Colorado (08/26/2008)

DATE CONSIDERED 10/26/2008

EXAMINER: Initial if citation considered, whether or not citation is in conformance with MPEP §609; Draw line through citation if not in conformance and not considered. Include copy of this form with next communication to the applicant.



<b>INFORMATION DISCLOSURE CITATION IN AN APPLICATION</b>	DOCKET NUMBER	PAICE201.DIV	APPLICATION NUMBER	10/382,577
	APPLICANT Severinsky et al			
	FILING DATE	3/7/2003	GROUP ART UNIT	361

**U. S. PATENT DOCUMENTS**

EXAMINER INITIAL	DOCUMENT NUMBER	DATE	NAME	CLASS	SUBCLAS	FILING DATE	
						YES	NO
DD	5 9 9 1 6 8 3	11/1999	Takaoka et al				
DD	5 4 7 3 2 2 8	12/1995	Nii				
DD	5 9 2 7 4 1 5	7/1999	Ibaraki et al				
DD	5 9 2 8 3 0 1	7/1999	Soga et al				
DD	6 1 7 6 8 0 7	1/2001	Oba et al				
DD	5 9 0 4 6 3 1	5/1999	Morisawa et al				
DD	5 7 8 9 8 7 7	8/1998	Yamada et al				
DD	6 0 8 7 7 3 4	7/2000	Maeda et al				
DD	5 9 7 3 4 6 0	10/1999	Taga et al				
DD	5 9 8 8 3 0 7	11/1999	Yamada et al				
DD	5 9 9 1 6 8 3	11/1999	Takaoka et al				
DD	5 8 1 8 1 1 6	10/1998	Nakae				

**FOREIGN PATENT DOCUMENTS**

	DOCUMENT NUMBER	DATE	COUNTRY	CLASS	SUBCLASS	TRANSLATION	
						YES	NO
DD	S 50 3 0 2 2 3	7/1973	Japan			X	
DD	W O 82 0 11 7 0	4/1982	PCT				
DD	0 5 1 0 5 8 2	12/1995	EPO				
DD	4 2 9 7 3 3 0	3/1991	Japan				X

**OTHER DOCUMENTS** (Including Author, Title, Date, Pertinent Pages, Etc)

DD	Minorikawa et al, "Current Status and Future Trends..." (Undated)
DD	Baum et al "Semiconductor Technologies..." (Undated)
DD	Chen "Automotive Electronics in the Year 2000..." (Apparently 1992)
DD	Brusaglino, SAE paper 910244 "Electric Vehicle Development..." (1991)
DD	Anderson et al, SAE paper 910246 "Integrated Electric..." (1991)
DD	Burke, SAE paper 911914 "Battery Availability for Near-Term..." (1991)

EXAMINER: Cynthia Collier (08/26/2008) DATE CONSIDERED 10/12/09 08/26/2008

EXAMINER: Initial if citation considered, whether or not citation is in conformance with MPEP §609; Draw line through citation if not in conformance and not considered. Include copy of this form with next communication to the applicant.





17

INFORMATION DISCLOSURE CITATION IN AN APPLICATION	DOCKET NUMBER	PAICE201.DIV	APPLICATION NUMBER	10/382,577
	APPLICANT Severinsky et al			
	FILING DATE	3/7/2003	GROUP ART UNIT	361

U.S. PATENT DOCUMENTS

EXAMINER INITIAL	DOCUMENT NUMBER	DATE	NAME	CLASS	SUBCLAS	FILING DATE

FOREIGN PATENT DOCUMENTS

DOCUMENT NUMBER	DATE	COUNTRY	CLASS	SUBCLASS	TRANSLATION	
					YES	NO

OTHER DOCUMENTS (Including Author, Title, Date, Pertinent Pages, Etc)

A B C D E F G H I J K L M N O P Q R S T U V W X Y Z AA AB AC AD AE AF AG AH AI AJ AK AL AM AN AO AP AQ AR AS AT AU AV AW AX AY AZ BA BB BC BD BE BF BG BH BI BJ BK BL BM BN BO BP BQ BR BS BT BU BV BW BX BY BZ CA CB CC CD CE CF CG CH CI CJ CK CL CM CN CO CP CQ CR CS CT CU CV CW CX CY CZ DA DB DC DD DE DF DG DH DI DJ DK DL DM DN DO DP DQ DR DS DT DU DV DW DX DY DZ EA EB EC ED EE EF EG EH EI EJ EK EL EM EN EO EP EQ ER ES ET EU EV EW EX EY EZ FA FB FC FD FE FF FG FH FI FJ FK FL FM FN FO FP FQ FR FS FT FU FV FW FX FY FZ GA GB GC GD GE GF GG GH GI GJ GK GL GM GN GO GP GQ GR GS GT GU GV GW GX GY GZ HA HB HC HD HE HF HG HH HI HJ HK HL HM HN HO HP HQ HR HS HT HU HV HW HX HY HZ IA IB IC ID IE IF IG IH II IJ IK IL IM IN IO IP IQ IR IS IT IU IV IW IX IY IZ JA JB JC JD JE JF JG JH JI JJ JK JL JM JN JO JP JQ JR JS JT JU JV JW JX JY JZ KA KB KC KD KE KF KG KH KI KJ KK KL KM KN KO KP KQ KR KS KT KU KV KW KX KY KZ LA LB LC LD LE LF LG LH LI LJ LK LL LM LN LO LP LQ LR LS LT LU LV LW LX LY LZ MA MB MC MD ME MF MG MH MI MJ MK ML MN MO MP MQ MR MS MT MU MV MW MX MY MZ NA NB NC ND NE NF NG NH NI NJ NK NL NM NO NP NQ NR NS NT NU NV NW NX NY NZ OA OB OC OD OE OF OG OH OI OJ OK OL OM ON OO OP OQ OR OS OT OU OV OW OX OY OZ PA PB PC PD PE PF PG PH PI PJ PK PL PM PN PO PP PQ PR PS PT PU PV PW PX PY PZ QA QB QC QD QE QF QG QH QI QJ QK QL QM QN QO QP QQ QR QS QT QU QV QW QX QY QZ RA RB RC RD RE RF RG RH RI RJ RK RL RM RN RO RP RQ RR RS RT RU RV RW RX RY RZ SA SB SC SD SE SF SG SH SI SJ SK SL SM SN SO SP SQ SR SS ST SU SV SW SX SY SZ TA TB TC TD TE TF TG TH TI TJ TK TL TM TN TO TP TQ TR TS TT TU TV TW TX TY TZ UA UB UC UD UE UF UG UH UI UJ UK UL UM UN UO UP UQ UR US UT UU UV UW UX UY UZ VA VB VC VD VE VF VG VH VI VJ VK VL VM VN VO VP VQ VR VS VT VU VV VW VX VY VZ WA WB WC WD WE WF WG WH WI WJ WK WL WM WN WO WP WQ WR WS WT WU WV WW WX WY WZ XA XB XC XD XE XF XG XH XI XJ XK XL XM XN XO XP XQ XR XS XT XU XV XW XX XY XZ YA YB YC YD YE YF YG YH YI YJ YK YL YM YN YO YP YQ YR YS YT YU YV YW YX YZ ZA ZB ZC ZD ZE ZF ZG ZH ZI ZJ ZK ZL ZM ZN ZO ZP ZQ ZR ZS ZT ZU ZV ZW ZX ZY ZZ	Chang, IEEE AES Magazine (1993) "Recent Developments of Electric ..."
	Kamiyama et al, IEEE 0-7803-0582-5 (1992) "Application Trends...."
	Sen, IEEE Trans. Ind. Elec. (1990) "Electric Motor Drives..."
	Wang et al, PCSC '71 Record, "Analysis of SCR Chopper Drive" (1971)
	EPRI Report TR-101264 "Assessment of Electric Motor Technology (1992)
	Berman et al, SAE paper 720111 "Electric Car Drives...." (1972)

EXAMINER <i>[Signature]</i>	DATE CONSIDERED <i>ns/ha/pcc</i>
-----------------------------	----------------------------------

EXAMINER: Initial if citation considered, whether or not citation is in conformance with MPEP §609; Draw line through citation if not in conformance and not considered. Include copy of this form with next communication to the applicant.





IN THE UNITED STATES PATENT AND TRADEMARK OFFICE

In re the Patent Application of :  
: Severinsky et al : Examiner: David Dunn  
: Serial No.: 10/382,577 : Group Art Unit: 3616  
: Filed: March 7, 2003 : Att.Dkt.: PAICE201.DIV  
: For: Hybrid Vehicles :

Hon. Commissioner for Patents  
P.O. Box 1450  
Alexandria VA 22313-1450

**SECOND SUPPLEMENTAL INFORMATION DISCLOSURE STATEMENT**

Listed on attached PTO-1449 forms are a number of documents that have come to applicants' attention since the filing of the Supplemental Information Disclosure Statement filed in this application on May 28, 2004. Applicants' thus making these documents of record should not be deemed a concession that they are necessarily available as prior art as defined by 35 USC Sect. 102. The Examiner is respectfully requested to consider these newly-cited documents and to indicate that he has done so in the file of this application.

The relevance of the newly-cited documents to the present invention is summarized as follows:

Japanese Patent Application Publication 7-54983 (Nakagawa et al) (provided with noncertified translation) shows controlling the shifting of an automatic transmission. The usual method is described as controlling the ratio based on detected engine load and vehicle speed,

following a predetermined shift pattern. Prior art shows detecting increase in loading, e.g., "uphill running", if the speed drops below shift boundary line while the throttle opening is over a predetermined value. This is stated to be workable only under limited circumstances. This invention calculates a "running load coefficient KFUKA" which is then smoothed and used to correct the predetermined shift pattern.

From paragraph 10, "[T]he running load coefficient KFUKA is calculated according to an equation  $KFUKA=2-(b/a)$  when the detected vehicle speed 'b' is lower than the standard loaded-vehicle speed 'a', and according to an equation  $KFUFA=a/c$  when the detected vehicle speed 'c' is higher than the standard value 'a' ". This is mathematically inconsistent, since both "b" and "c" are the "detected vehicle speed". Further, it is clear that KFUKA is a running load coefficient, that is, a correction factor somehow responsive to variation in running load, not the running load itself.

Japanese Patent Application Publication 4-244568  
(Onishi et al) (provided with noncertified translation) -  
Shifting of an automatic transmission is controlled responsive to a predictive program that calculates the torque to be available after shifting. Running load is employed in this calculation. It is stated to be determined as follows:

"(0022) The running load estimating means 101 now multiplies the torque converter output torque  $T_t$  by the gear ratio "r" to calculate the torque  $T_m$  generated at the wheels, and calculates the running load  $T_L$  based on the

relational formula  $T_L = T_m - M \cdot r_w \cdot \alpha$  from the vehicle mass  $M$ , the effective wheel radius  $r_w$  and the acceleration  $\alpha$ . The flow of this calculation shown in FIG. 6.

"(0023) In FIG. 6,

Step 601: Reading of the respective data of vehicle speed  $V_{SP}$  and engine rotational speed  $N$ , gear ratio "r" and acceleration  $\alpha$  is performed.

Step 602: the turbine rotational speed  $N_t$  is calculated by the following formula:

$$N_t = V_{SP}/120\pi/r_w \cdot r \times 1000$$

Step 603: Torque converter or rotational ratio "e" is calculated and pump torque coefficient  $\tau$  and torque ratio "t" are searched.

$$e = N_t/N, \tau = f_1(e), t = f_2(e)$$

Step 604: Pump torque  $T_p$  and turbine torque  $T_t$  are calculated.

$$T_p = \tau \cdot (N/1000)^2, T_t = t \cdot T_p$$

Step 605: Calculation of torque  $T_m$ .  $T_m = T_p \cdot r$

Step 606: Calculation of running load  $T_L$ .  $T_L = T_m - M \cdot r \cdot \alpha$ .

This makes no sense. In particular, it is clear that the idea is to correct the torque at the wheels  $T_m$  by the factor  $M \cdot r \cdot \alpha$  to reach the running load, but calculating  $M \cdot r \cdot \alpha$  does not yield a torque in units of kg-m, but a value in  $\text{kg} \cdot \text{m}^2/\text{sec}^2$ .

In any event it is clear that neither reference refers remotely to hybrid vehicles, much less controlling operating modes thereof responsive to road load.

US Patent 6,067,801 (Harada) is based on Japanese application 9-329430. The disclosure is directed to reducing driveline shock occasioned upon shutting off the engine in a hybrid by loading it using one of the two motor/generators. Road load per se is not discussed; mode switching is discussed only inferentially, e.g., "...at the time when the engine is not required, for example, during a reduction of the speed or a downslope run, the hybrid vehicle stops operation of the engine 150 and runs only

with the motor MG2" (col. 9, lines 40 - 43). Harada states nothing of relevance to operating the engine when loaded to above a setpoint SP.

However, this reference is generally relevant in that it acknowledges that the engine can be loaded by the battery charging load as well as the loading required for vehicle propulsion (col. 1, lines 15 - 17), that the engine can be shut off when not needed (as noted, col. 9, lines 40 - 43) and that it should be operated at an efficient operating point (same). The vehicle's power requirements, including power for acceleration, for charging, and for auxiliaries, is calculated, and a decision made whether the engine is required. Engine activation is based on vehicle speed, or the necessity of battery charging (col. 10, line 41 - col. 11, line 18). The engine is run at low power levels (col. 12, line 49), and idling is permitted (col. 11, line 65). The engine can be motored to warm it up prior to starting (col. 12, line 17). It is noted that for a given output power requirement it is more efficient to run the engine at lower RPM and higher torque than at higher RPM and lower torque output (col. 13, lines 34 - 45). The minimum RPM of the engine in the loaded state is maintained greater than in the non-loaded state, in order to allow gentle variation in torque applied to the motor MG1 during mode changes, avoiding rough operation (col. 16, lines 17 - 38), not so as only to operate the engine when loaded to the point of efficient operation. Most of the topologies shown involve the usual planetary gearset for combining the torque from the engine and two motors, but an embodiment is shown in Fig. 12 which avoids the planetary gearbox and first motor in favor of a "clutch motor MG3" which includes first and second rotors that function as an

electromagnetic coupling (col. 18, lines 43 - 56). A series hybrid version, in which the engine never transmits torque directly to the wheels, is shown in Fig. 13.

Japanese Patent Application Publication 11-122712 (Morita et al) (provided with partial noncertified translation) shows a hybrid with a traction motor and engine propelling the vehicle; a second motor drives the ancillaries and starts the engine (there is no suggestion that this second motor is used to charge the battery), so the topology is effectively a single-motor hybrid with a separate starter. The invention is essentially to disengage a clutch connecting the engine and wheels upon braking, so that the engine can be shut off; when braking ends, the starter is used to motor the engine, and when the accelerator is then applied fuel is supplied and the engine started. Mode shifting is thus performed strictly in accordance with the operation of the accelerator and brake pedals.

Japanese Patent Application Publication 11-113956 (Hisamura) (provided with partial noncertified translation) shows a control device for a continuously variable transmission. The slope of the road being driven on is determined by a calculation employing the actual torque being supplied and the vehicle speed and acceleration. The "flatland" required torque is calculated and compared to the actual torque, to determine the slope of the road, and the transmission ratio adjusted accordingly.

Japanese Unexamined Patent Publication 11-82260 (Tsuzuki et al) (supplied without translation) - Topology

includes engine, first clutch, motor/generator, second clutch, and automatic transmission, and wheels, in that order. In order to reduce shock upon engine starting, the second clutch is opened and left open until the engine and motor/generator are synchronized. This would be completely useless, since power flow to the wheels would be interrupted, seriously impacting drivability. Moreover, this would occur under acceleration, just when it would be most annoying and possibly even unsafe.

Japanese Unexamined Patent Publication 11-82261 (Tsuzuki et al) (supplied without translation) is closely related to the above Tsuzuki patent application. According to notes provided by our searcher, this simply adds the idea of providing a starter on the engine. This would suffer the same drivability problem.

According to our German searcher, German applications 198 38 853, 102 60 435, and 198 14 402, (all supplied without translations) describe methods for starting the engines of single motor hybrids.

Fiala US patent 4,411,171 shows a single-motor hybrid wherein the engine is connected through a first clutch to one side of a flywheel; a second clutch on the other side of the flywheel allows the flywheel to be locked to the output shaft, for direct drive, or to serve as the sun gear of a planetary gearbox. The planet carrier is connected to the output shaft, and the ring gear to a single motor/generator. The flywheel can also be locked, which provides an electric-car mode. The vehicle must be stopped to allow starting of the engine (col. 3, line 55), so



clearly the vehicle must be operated in distinct low speed (electric car) and high-speed hybrid modes. The engine is to be used to start the vehicle from a standing stop by using some of the engine's torque to drive the motor/generator, i.e., the motor/generator acts as a brake (col. 5, lines 1 - 7), with the planetary gearbox thus decoupling the engine from the output shaft.

Maeda U.S. patent 3,620,323 shows a hybrid vehicle in which the engine is intended to be operated at full throttle at all times; see the abstract, col. 1, lines 37 - 38, col. 5, lines 13 - 15.

Tabata et al U. S. Patent 6,317,665 is directed to control of a lock-up clutch in a hybrid vehicle so as to smooth transitions between operation in motor-drive and engine-drive modes. Tabata et al patent 6,183,389 is also directed to control of operation of lock-up clutches. Finally, Tabata patent 5,887,670 is also directed to smoothing transitions.

Hagiwara patent 5,565,711 is the US equivalent to a Japanese patent document cited against a Japanese application claiming priority from the same basic application as the present application. The Hagiwara patent relates to specifics of the connection of the individual batteries in a battery bank. No claims are pending in this application which are drawn to this aspect of the invention.

Again, the Examiner is respectfully requested to consider these documents, and to indicate that he has done so in the file of the application.

Dated: 2/17/05

Respectfully submitted,

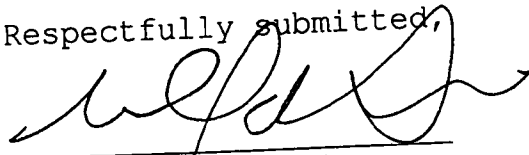

Michael de Angeli  
Reg. No. 27,869  
60 Intrepid Lane  
Jamestown, RI 02835  
401-423-3190

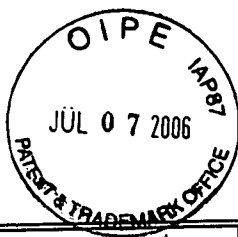

INFORMATION DISCLOSURE CITATION IN AN APPLICATION  1/2	DOCKET NUMBER	PAICE201.DIV	APPLICATION NUMBER	10/382,577
	APPLICANT			
	Severinsky et al			
FILING DATE		3/7/2003	GROUP ART UNIT	3616

**U. S. PATENT DOCUMENTS**

EXAMINER INITIAL	DOCUMENT NUMBER	DATE	NAME	CLASS	SUBCLAS	FILING DATE	
DD	6 0 6 7 8 0 1 5	15/2000	Harada et al				
DD	4 4 1 1 1 7 1 1	10/1983	Fiala				
DD	3 6 2 0 3 2 3 5	1968	Maeda				
DD	6 3 1 7 6 6 5 11	11/2001	Tabata et al				
DD	6 1 8 3 3 8 9 2	12/2001	Tabata et al				
DD	5 5 6 5 7 1 1 1	10/1996	Hagiwara				

**FOREIGN PATENT DOCUMENTS**

DOCUMENT NUMBER	DATE	COUNTRY	CLASS	SURCLASS	TRANSLATION	
					YES	NO
DD 7 5 4 9 8 3	2/1995	Japan			X	
DD 4 2 4 4 6 5 8	9/1992	Japan			X	
DD 11 0 8 2 2 6 1	3/1999	Japan				X
DD 11 1 2 2 7 1 2	4/1999	Japan			Partial	
DD 62 1 1 3 9 5 6	5/1987	Japan			Partial	

**OTHER DOCUMENTS** (Including Author, Title, Date, Pertinent Pages, Etc)

EXAMINER <i>[Signature]</i>	DATE CONSIDERED 3/16/05
-----------------------------	-------------------------

EXAMINER: Initial if citation considered, whether or not citation is in conformance with MPEP 6609; Draw line through citation if not in conformance and not considered. Include copy of this form with next communication to the applicant.



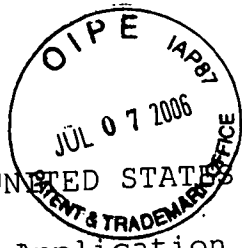

IN THE UNITED STATES PATENT AND TRADEMARK OFFICE

In re the Patent Application of :  
Severinsky et al :  
Serial No.: 10/382,577 :  
Filed: March 7, 2003 :  
For: Hybrid Vehicles :  
Hon. Commissioner for Patents :  
P.O. Box 1450 :  
Alexandria VA 22313-1450 :

Examiner: N/A  
Group Art Unit: 3616  
Att. Dkt.: PAICE201.DIV

**SUPPLEMENTAL INFORMATION DISCLOSURE STATEMENT**

Sir:

As discussed in the Preliminary Amendment dated August 11, 2003 in this application, applicants have performed additional searching for new patents possibly relevant to the subject matter of this application as amended, and other new patents and other documents have also come recently to applicants' attention. A number of patents and other documents thus located are listed on attached PTO-1449 forms, and are discussed below. Citation of a document herein should not be considered an admission that the disclosure thereof is indeed relevant to the invention defined by the claims, nor that the document thus made of record is indeed effective as prior art under 35 USC '102.

A correction is also desirable with respect to a statement made in an earlier Information Disclosure Statement (IDS). In the IDS filed on November 18, 1999 in grandparent application Ser. No. 09/264,817, which has been incorporated by reference to form part of the IDS for the present application, Taniguchi patent 5,846,155 was described as showing "a parallel hybrid of generally conventional topology, that is, comprising an ICE [internal combustion engine] and an electric motor connected to

the road wheels of the vehicle through a continuously-variable transmission, but discloses a relatively sophisticated operational scheme, wherein the source of propulsive torque varies in accordance with the road load and the state of charge of the battery bank ('SOC').

This could be misunderstood to suggest that Taniguchi suggests control of the hybrid vehicle's operating mode responsive to the road load and SOC. In fact, Taniguchi does not teach selection of the source of vehicle propulsive torque, much less the operating mode, in accordance with the road load and SOC, but in response to vehicle speed and accelerator pedal position. See col. 8, lines 13 - 40:

Moreover, the individual engagement means, as shown in FIGS. 4 and 5, are operated as shown in the operation diagram of FIG. 6. *In the power split mode, the split drive unit 9 functions at the start and at a low/medium speed.* The output of the engine 2 is transmitted to the ring gear R through the input clutch Ci. On the other hand, the rotor 5a of the motor-generator 5 is connected to the sun gear S to charge the engine output partially or to output it as the motor so that the composed force is output from the carrier CR to the CVT input shaft 7a.

On the other hand, *the parallel hybrid mode functions in a medium/high speed range.* In this state, the rotary elements of the planetary gear 6 are rotated together, and the output of the engine 2 is fed as it is to the CVT input shaft 7a. At the same time, the motor-generator 5 is connected to the input shaft 7a to assist the engine output or to charge the output partially.

*The motor mode is in the state in which the accelerator opening is small and in which the revolution number is small, e.g., in which the engine 2 need not be used, such as in a traffic jam.* Then, the motor-generator 5 is used as the motor to drive the vehicle. In this state, the input clutch Ci is released to disconnect the engine 2 and the CVT input shaft 7a, and the direct-coupled clutch Cd is applied to output the revolution of the motor-generator rotor 5a directly to the input shaft 7a.

*On the other hand, the engine mode functions during high speed cruising, and the vehicle is driven exclusively by the engine output without any participation of the motor-generator 5.* [Emphasis added].

The Examiner is respectfully requested to review the Taniguchi reference and confirm that in fact the road load is not used to determine the operating mode; in fact, Taniguchi controls the operation of the CVT, and the source of propulsive torque, in response to the vehicle speed and accelerator pedal position.

Turning now to new documents made of record hereby:

Abe 6,281,660 shows a battery charger for an electric vehicle.

Adler et al patent 5,515,937 claims a series hybrid where the power required by traction motors is drawn from either the batteries or directly from the engine/generator unit directly, depending on evaluation of their respective efficiencies and the batteries' state of charge, with respect to each new demand for power.

Barske patent 5,336,932 ties the operation of a generator used to charge a battery to specific fuel-consumption curves stored in ROM.

Bullock patent 6,170,587 shows a hybrid drive, all claims of which require at least three different types of energy storage, e.g., combustible fuel, battery, flywheel, or hydraulic accumulator.

Fattic et al patent 5,637,987 shows a hybrid vehicle in which an internal combustion engine and motor are coupled by controllable friction or electrical loading devices to control ratios.

Gray, Jr. patent 5,887,674 relates to a vehicle driven by a "fluidic motor", that is, having a hydraulic motor driving the wheels, in turn driven by a pump driven by an internal combustion engine.

Patent 4,762,191 to Hagin discloses a hybrid power train for a bus wherein multiple axles are driven via a driveshaft. Some of the dependent claims of the present application, recite connection of the combination of engine and first electric motor to a first set of wheels and connection of the second electric motor to a second set of wheels, which is quite different.

Hoshiya patent 6,315,068 shows a hybrid in which control of the torque provided by the motor is responsive to the torque provided by the engine, so that the engine can be operated at a target speed.

Ibaraki patent 5,856,709, discloses and claims a hybrid topology wherein an engine and a motor/generator are connected to different elements of a "synthesizing/distributing mechanism". A large number (nine or more) of operating modes are provided. The determination of the amount of torque required to propel the vehicle is apparently made in response to the position of the accelerator pedal; see col. 15, lines 59 - 61.

Patent 6,225,784 of Kinoshita claims a battery charge controller for a vehicle, wherein the level of charge above which further charging is permitted is varied based on the battery temperature. Patent 6,232,748 to the same inventor and assignee allows only discharge when the battery is above a specified temperature, and patent 6,204,636, again to the same inventor and assignee, controls the charging and discharge rate of the battery responsive to sensing of the "memory effect" of the battery. None of these expedients are claimed in the present application.

Four Lawrie and Lawrie et al patents, 5,993,350, 6,019,698, 5,979,257, and 6,006,620, and Reed et al 5,943,918 (et al here including Lawrie) are directed to transmissions for hybrids that combine the efficiency of manual transmissions with the convenience of automatic transmissions. Motors are used to operate the conventional "H"-pattern shifter, and a clutch, while



the motor/generator present in a hybrid is employed to match the speeds of input and output shafts, to ensure smooth shifting. Finally, Reed, Jr. et al 6,332,257 claims a method of converting a manual transmission to automated operation.

Lovatt et al patent 6,291,953 shows an "electrical drive system", in some cases applied to a hybrid vehicle, requiring a lock-up torque converter.

Minowa et al patent 6,142,907 (Hitachi) claims a hybrid wherein either an engine or a motor is used to propel the vehicle. A generator is selectively connected to the wheels through a two-speed transmission. Patent 6,328,670 is a continuation.

Morisawa et al 5,984,034 discloses a hybrid wherein regenerative braking is used to oppose engine torque when idling to keep the vehicle stopped. Morisawa et al 6,119,799 issued on a continuation and discloses a hybrid offering control of braking responsive to "obstruction [e.g., a car ahead] detection". Another patent based on the same underlying document, no. 6,334,498, claims supplying power from a motor during upshifts of an automatic transmission being driven by an engine. None of these is a feature of the claimed invention.

Another Morisawa patent, no. 5,895,333, is limited to packaging details for a planetary gearbox for a hybrid vehicle. Still another Morisawa patent, no. 6,306,057, claims a complex planetary gearbox arranged so that the internal combustion engine is used to power the vehicle when reversing.

Nagano et al 6,344,008 discloses a hybrid wherein a transmission is coupled between an engine and a torque synthesizing device, which also accepts torque from a single motor.

Nakajima et al 6,090,007 shows a control scheme for a hybrid vehicle including a continuously variable transmission. Patent

6,328,671 to Nakajima et al is a continuation-in-part of the '007 patent and shows setting the "target drive power" based on the accelerator pedal position and vehicle speed.

Nekola patent 5,660,077 shows a variable-speed transmission stated to be useful in a hybrid vehicle, including a cone-shaped gear; the meshing gear slides along the conical gear to vary their relative speeds.

Nitta patent 6,321,150 shows an abnormality monitoring system that is responsive to faults in a very specific type of communication scheme that can be used for a hybrid vehicle.

Another Nitta patent, no. 6,203,468, requires first and second motors on either side of a lock-up clutch, to smooth transitions between series and parallel operation.

Nogi et al patent application US 2001/0037905 is directed to lean-burn operation of a hybrid.

Omote patent 5,944,630 claims controlling torque applied by a motor during shifting operations, to smooth shift transitions.

Oyama patent 6,070,680 relates to prevention of stalling of the engine of a hybrid vehicle due to rapid deceleration; the traction motor provides torque to the engine in such cases.

Patent 6,123,642 to Saito claims a "speed change control apparatus" wherein a motor is connected to the wheels of a vehicle through a multispeed transmission; power to the transmission is cut during shifting.

Tabata et al patent 6,158,541 shows a hybrid vehicle wherein the battery is divided into several portions so that one or more can be completely discharged while the others remain partially charged.

A further Tabata et al patent, no. 5,847,469, is directed to a hybrid wherein the electric motor is employed for reversing if the battery is sufficiently charged, and the engine otherwise.

Another Tabata et al patent, no. 6,317,665, shows a hybrid in which a torque converter with lock-up clutch is disposed between the engine and motor and the wheels; the claims require the lock-up clutch to be released during mode switching to prevent rough running.

Another Tabata patent, no. 6,183,389, is directed to hybrids having "torque transmission systems" (i.e., torque converters; see col. 1, line 52) fitted with lock-up clutches; the invention has to do with the control system for the clutch.

Yet another Tabata et al patent, no. 5,873,426, claims a hybrid having an automatic transmission with differing shift patterns selected depending on the load; apparently, the engine is used as the only torque source in one mode and the engine and motor together in another.

Another Tabata et al patent, no. 5,923,093, recites in claim 1 that the automatic transmission is inhibited from shifting during regenerative braking, in claim 5 "braking shift control means" used when regenerative braking is not available, to downshift the transmission to increase engine braking, in claim 13 braking shift control means operated similarly prior to operation of regenerative braking, in claim 17 a clutch between transmission and engine that is engaged during regenerative braking, and in claim 23 means for preventing changing between engine and regenerative braking during a braking operation.

Still a further Tabata et al patent, no. 6,340,339, is limited to specific constructional details of a motor and transmission assembly for a hybrid.

In another Tabata et al patent, no. 5,935,040, claims 1, 5, 7, and 9 all require a manually-operated member for selecting drive modes, while claim 3 requires an automatic transmission operated so that the drive force remains constant in various drive modes as long as the required output remains constant.

Takaoka et al patent application US 2003/0085577 has claims drawn to control of gear selection in an automatic transmission for a hybrid based on engine efficiency; apparently, if the torque required cannot be supplied efficiently by the engine and motor working together, the transmission is downshifted.

Tuzuki et al patent 5,415,603 shows details of a hydraulic system for a hybrid vehicle in which the oil is used for cooling of a traction motor and lubrication of the transmission.

Wakuta et al patent 6,258,001 is directed to very narrow mechanical aspects of a motor and transmission assembly for a hybrid.

Woon et al patent 5,890,470 claims a method of controlling engine output power, evidently intended to improve on conventional governors as used on diesel engines to smooth throttle response and shifting. Claim 1 is typical and requires operating the engine at a constant horsepower value responsive to throttle position regardless of engine speed.

Yamada et al patent 6,328,122 discloses a series hybrid wherein the ICE can be used for vehicle propulsion only in the event of a failure in the charging system.

Nada patent 6,653,230 is also directed to operation of a hybrid after a particular failure.

Yamaguchi patent 5,915,489 shows a hybrid powertrain. It appears that the output torque is determined based on vehicle speed and accelerator pedal position; see col. 6, lines 17 - 21.

Yamaguchi et al patent 6,278,195 shows applying torque from the electric motor of a hybrid to quickly stop the engine.

Yamaguchi et al patent 6,247,437 claims control of the operation of a starter motor, e.g., for a hybrid, responsive to an engine parameter relevant to its startability. For example, if the engine is cold, fuel is supplied at a lower cranking RPM

to limit the drain on the battery. A divisional application (not being supplied), Yamaguchi et al published patent application 2001/0022166, similarly claims a starting control for an engine, in which the rotating speed is limited when the engine is cold to avoid excessive use of battery power.

Yamaguchi patent 5,967,940 is directed to control of the power provided by the engine of a hybrid to prevent noise due to gear backlash.

Yamaguchi 6,135,914 discloses a method of control of a hybrid including an ICE and two motor/generators. The invention has to do with limiting the engine speed so that the first motor/generator is not rotated beyond its capability in the event of a failure. The Yamaguchi system operates in engine-only, motor-only, and engine+motor modes (see col. 4, lines 46 - 54), but the method by which the choice between these is made is not explicit.

Field patent 5,081,365 discloses a hybrid vehicle wherein an engine is connected to road wheels through an electric motor, which is operated variously as traction motor or generator, depending on the batteries' state of charge and the vehicle operating mode; the operating mode is selected by the operator from an urban mode, a highway mode, an engine mode, and a cruise control mode. The selection is apparently to be made responsive to motor speed. Field acknowledges at col. 7, line 48 the desirability of operating the engine near its rated power to thus realize high efficiency; as discussed in detail below, Field suggest using an engine that is sized so that it operates at nearly maximum output during flat-highway, constant speed cruising. Such an engine would necessarily be too small to propel the vehicle up hills, so its performance would suffer under such circumstances.

Two additional patents to Field and Field et al, nos. 6,044,922 and 6,481,516, relate to developments of the system disclosed in the '365 Field patent above; the '516 patent is stated to be a continuation of the '922 patent, but their disclosures are not in fact identical. The vehicle described in these patents comprises two separate battery packs, a high-voltage battery pack for supplying power to the traction motor and a lower-powered accessory battery for operating usual vehicle ancillary components such as lights, radio, and the like.

Kubo patent 5,722,502 shows a hybrid vehicle comprising an ICE, a generator and a traction motor also operable as a generator. The vehicle can be operated in a variety of modes, include PEV ("pure electric vehicle", in which the ICE is not run at all; see col. 10, lines 18 - 28), SHV ("serial electric vehicle", wherein the ICE is run to drive the generator, which in turn supplies current to the traction motor to power the vehicle; see col. 5, lines 33 - 51), and "continuous-type PSHV" ("parallel-serial hybrid vehicle", where torque from the ICE is used to propel the vehicle and to drive the generator to power the traction motor to propel the vehicle if torque from the ICE is inadequate; see col. 5, lines 52 - 66). A distinction is drawn between this continuous-type PSHV and a "changeover-type PSHV", as exemplified by Japanese Laid-Open Publication 2-7702; see col. 3, lines 2 - 9 and col. 5, line 66 - col. 6, line 10.

The selection between the PEV mode and one or the other of the SHV and PSHV modes is made by the operator (see col. 10, line 47), while the selection between SHV and PSHV modes is made according to the battery's state of charge (SOC); see col. 6, lines 12 - 13. When the driver selects a mode other than the PEV mode, the engine is operated continuously (col. 11, lines 26 - 32), and may idle when not significantly loaded (col. 12, lines 31 - 32; col. 13, lines 51 - 52); if the battery is fully charged

but braking is required, such that regenerative braking would be inappropriate, the engine can be operated as a mechanical brake (col. 11, lines 6 - 20).

In PSHV mode, an engine control unit (ECU) then determines whether torque is to be supplied from the traction motor, ICE, or both, depending on the accelerator pedal angle: "Further, if the change in accelerator pedal angle is too large for the torque to be supplied...by the ICE alone or...by the ICE alone because fuel consumption and emission are degraded, the ECU 20 controls the [inverter] to compensate by using the motor 10 for at least that part of the torque required at the driving wheels." (Col. 13, lines 32 - 39). At low speeds in PSHV mode, it appears that the ICE provides power to the traction motor through the first motor, being operated as a generator.

Tsukamoto et al 5,771,478 shows a hybrid vehicle in which the function of a clutch or torque converter, allowing slipping of an ICE with respect to the wheels of a vehicle, e.g., when accelerating from a stop, is provided by a gearbox connected between the ICE, wheels, and a motor-generator. Excess torque provided by the ICE at starting is absorbed by the motor-generator and stored in a battery; it can then be used to run accessories or propel the vehicle.

Tabata et al 5,833,570 relates to smoothing the shifting of an automatic transmission of a hybrid by application of torque from the traction motor. Tabata 5,951,614 is generally similar, but shows smoothing of shifting by reducing the torque supplied by either the motor/generator or ICE.

Hata et al 5,875,691 discloses and claims a specific arrangement of the components of a hybrid (ICE, motor, transmission) for packaging convenience.

Haka 5,931,271 shows a hybrid powertrain wherein one-way clutches are provided so that the same motor/generator can start

an ICE and be disconnected therefrom for efficient regenerative braking.

Shibata et al patent 3,719,881 shows a battery charger arrangement especially for a serial hybrid vehicle, wherein an internal combustion engine is operated to drive a generator only above a minimum load, so as to reduce emissions, which increase at low loads.

Etienne patent 4,187,436 also shows a battery charging arrangement for a serial hybrid vehicle, which includes a first battery for powering the traction motor and a second battery for starting the ICE.

Lynch et al patent 4,165,795 shows a hybrid drive arrangement in which an ICE and a motor/generator are mechanically coupled to one another, and to the wheels of the vehicle, through a transmission. The engine is sized to provide the average power necessary for ordinary driving, and is operated near its optimal efficiency point at all times; the motor/generator is operated for load-leveling, that is, when the vehicle's torque requirements exceed the power provided by the engine the motor/generator adds torque, and when the engine's torque output exceeds the vehicle's torque requirement, the motor/generator operates as a battery charger. The difficulty with this approach is simply that the vehicle's torque requirements may vary by a factor of up to 1000%, or more, between city driving and highway driving, particularly when there are grades (using battery power to climb a grade of any length will quickly discharge any reasonably-sized battery bank) so this solution is not useful in "real-world" driving.

Hadley et al 5,283,470 shows an electric car, that is, without ICE, with regenerative braking. Hadley et al 5,406,126 is similar.



Schmidt 5,669,842 shows a hybrid drive in which either the ICE or one of several separate motors drive the accessories, depending on whether the engine is running. The engine and motors are arranged so that the engine and the mating member of the geartrain are driven at the same speed, allowing the clutch to be synchronously engaged.

Ibaraki et al 6,003,626 discloses a hybrid in which the engine normally propels the vehicle and charges the battery through a generator; if the generator fails, the engine propels the vehicle.

Takahara et al 6,009,365 discloses a hybrid with ICE and motor connected to the wheels through a continuously variable transmission (CVT). During coasting the actual torque being exerted is compared to a calculated desired torque and the actual torque adjusted accordingly.

Bower patent 6,231,135 relates to improvements in brake systems for hybrid vehicles. Although the present application is a division of an application which was a continuation-in-part of earlier applications, and which added disclosure of a new braking system to the disclosure of the parent application, no claims to that braking system are now being pursued in this application.

Soejima 5,951,118 discloses a vehicle braking system, not limited to hybrids, which includes a seating velocity reducing device for slowing the closing of a valve; this can be employed together with regenerative braking in a hybrid. Otomo et al 5,984,432 is similar. As above, no claims of the present application are directed to improvements in braking systems, although the parent was a C-I-P which added material relating thereto to the disclosure of the grandparent application.

Numazawa et al patent 5,497,941, Umebayahi et al patent 6,265,692, and Matsuda et al patent 6,357,541 all relate to improvements in HVAC systems. As in the case of the braking

systems discussed above, no claims are currently being pursued to certain new material relating to HVAC systems that was added by the parent C-I-P application to the disclosure of the parent applications.

Takahara et al patent 6,064,161 shows operating a motor/generator of a hybrid to brake a slipping wheel. This is not a feature of the claimed invention. Takahara also shows that the vehicle operating mode can be controlled responsive to accelerator pedal position and vehicle velocity, in common with many other references. See Fig. 5.

Kaiser et al 5,979,158 suggests that emissions of an ICE on starting can be reduced by spinning the ICE to a speed approximating its idle speed, activating the ignition system for about a second, and only then activating the fuel supply. This is suggested to be useful in a hybrid. No claims of the present application are directed to high-rpm starting, although the advantages of doing so are discussed in the application. Kaiser also mentions preheating of the catalyst; this step is recited in claim 77, but is not solely relied upon for patentability. Claim 77 recites, *inter alia*, that the vehicle's operating mode is selected responsive to road load, which is not shown by Kaiser.

Salecker 5,983,740 discloses a system for controlling the engine speed during shifting of an automatic transmission to smooth transition between gears; there is a brief mention that this could be useful in a hybrid.

Salecker 6,006,149 has a closely related disclosure and claims continuing to monitor operating parameters, especially temperatures of various components, for a time (the example being one second) after the engine has been shut off.

Yang patent 5,562,566 is extremely difficult to understand, but appears to disclose a power unit combining an ICE and a motor, which is stated to be useful in vehicles, ships, aircraft,

and in industrial and process equipment. The invention seems to be directed to a unit for combining the torque, but again the patent is extremely difficult to understand. Patents 5,547,433 and 5,549,524, also to Yang, appear to be directed to related inventions.

Origuchi patent 5,212,431 is directed to a serial electric hybrid vehicle wherein a generator, preferably to be driven by a gas turbine, is operated in response to monitoring of the battery's state of charge.

Antony et al 5,714,851 shows a serial hybrid with a bypass current path around the rectifiers and battery, to connect a generator driven by an ICE directly to a traction motor.

Horwinski patent 3,904,883 discloses a hybrid, wherein a single electric motor/generator is provided with separably rotatable armature and rotator, so that the unit can be operated as both motor and generator. An ICE is provided to drive the unit, and also to propel the vehicle under various conditions. Mode switching is apparently to be accomplished responsive to the battery's state of charge; see col. 5, lines 20 - 21 and col. 6, lines 64 - 66. The vehicle is intended to operate primarily as an electric car, with overnight charging from the power grid (see col. 6, lines 45 - 51) with the engine primarily provided as a range-extender, though, as noted, the engine can supply torque to the wheels; see col. 5, line 64 - col. 6 line 30.

Reichmann et al 5,851,698 and Venkatesan et al 5,856,047 are directed to nickel-metal hydride (NiMH) batteries optimized for hybrid vehicle applications.

Park 4,331,911 shows a method for equalizing the voltage across individual cells of storage batteries.

Miller et al 4,126,200 shows a vehicle having a flywheel for energy storage. Hagin et al 4,216,684 is similar. Matthews 4,591,016 shows recovering energy during regenerative braking by

accelerating a flywheel. Michel 4,592,454 shows doing so employing a hydropneumatic accumulator.

Stuhr 4,674,280 shows an accumulator for the storage of energy in a hydraulic system.

Fiala 4,416,360 shows a vehicle powertrain in which a flywheel connected to the engine by a clutch is rotated by a starter motor, and then used to start the engine using rotational inertia stored in the flywheel; the "starter" motor can then be operated as a generator to recharge the battery.

Moore 4,090,577 shows a hybrid with a conventional engine/transmission assembly driving one pair of wheels, with a solar-charged battery and motor combination driving a second pair.

Walker 5,323,688 discloses hydraulic wheel motors stated to be capable of regenerative braking.

Coe 5,384,521 discloses flywheel energy storage for a vehicle, with electromagnetic couplers.

Boll et al 5,623,194 shows a charge information system for an electric or hybrid vehicle for monitoring battery status and advising the operator.

Weiss 5,947,855 shows a hybrid drive for a tractor or the like wherein torque from an ICE is combined with torque from an electric motor, driven by a generator powered by the ICE is combined individually at the drive wheels by a "Ravigneaux" summing gear set. This is stated to provide flexibility in control.

Smith 5,971,088 shows a battery charging apparatus for regenerative charging wherein the generator is built into the vehicle driveshaft and moves with it as the vehicle encounters bumps and the like.

Walker 5,971,092 shows a hybrid comprising two ICEs, sized to accomodate differing typical loads, plus a hydraulic

accumulator. The engines are preferably two-strokes with "inertia pistons" sliding in bores in the main pistons.

Schulze et al 5,675,203 shows a motor/generator; the direction of rotation of the output shaft can be reversed by axial movement of a short-circuit winding.

Fliege 5,675,222 shows switchable winding motors for electric road vehicles.

Fliege 5,915,488 shows reducing the power supplied to switching components in a hybrid drive in response to detection of acceleration over a limiting value, e.g., to prevent sparking and erosion of switch contacts as they are jarred apart over bumps.

Lutz 5,679,087 and 5,685,798 disclose details of planetary gearboxes for vehicles.

Lutz 5,691,588 shows a clutch assembly for connecting motor and ICE of a hybrid, having separately-actuated friction plates on opposite sides of a hub forming part of the rotor.

Lutz et al patent 5,755,302 discloses a specific arrangement of a clutch connecting an engine, motor, and transmission of a hybrid - the rotor is attached to the transmission shaft and the stator to either the engine or the transmission housing, while the clutch also fits at least partially within the stator.

Fliege 5,678,646 discloses modular motors that can be stacked with interconnected coolant circuits to provide different power capacities, stated to be useful in hybrids.

Ruthlein et al 5,698,905 relates to emergency starting of a hybrid with a dead battery, by rearranging connections to allow starting by towing.

Lutz 5,713,427 shows a coupling structure for a hybrid comprising a deformable, resilient disc member.

Lutz 5,829,542 shows vehicles with separate motors on each wheel of at least one pair of wheels.

Welke patent 5,833,022 shows a specific constructional arrangement for a clutch and single traction motor of a hybrid vehicle. No operating scheme is discussed.

Adler et al 5,816,358 shows automatic disconnection of the current supply in the event of accident or the like in vehicles having relatively high current and voltage electric power supplies, e.g., hybrid vehicles.

Gardner 4,753,078 shows a hopelessly complicated hybrid vehicle design involving, among other impracticalities, "recovery of electricity from electromagnetic wind generators, gyrogenerators, and gravitational generators, and for the recovery of compressed air from air pumps...replacing the standard shock absorbers."

Wicks 5,000,003 shows a "combined cycle" engine wherein heat normally lost in the exhaust gases and rejected by heat exchange with cooling water from an ICE is recovered and used to drive a turbine or the like, and suggests that this might be especially suitable for use in a hybrid vehicle.

Lay 5,141,173 shows a vehicle capable of flight as well as travel along the ground. An ICE can propel the vehicle or drive a generator and thence electric motors, depending on the range and speed of intended travel.

Kutter 5,242,335 shows a drivetrain for a hybrid vehicle, shown in automobile and bicycle embodiments, wherein muscle power is combined with power from an auxiliary motor.

Kuang 5,264,764 shows use of an ICE as a power source to serve as a range extender for an electric car, that is, the ICE does not directly propel the vehicle.

Addie 3,699,351 shows a bi-modal vehicle, such as a rail car, which can be propelled by an external power source, such as a third rail, or by a prime mover, such as a gas turbine. A split torque device allows some of the turbine torque to be

delivered to the output shaft and the remainder to a motor/generator combination.

Shibata et al 3,719,881 shows a series hybrid, that is, an electric car comprising an ICE arranged to charge a battery connected to a traction motor, wherein the battery's state of charge is monitored and used to control operation of the ICE; the load on the ICE is monitored and the ICE is shut off when the load drops below a predetermined value.

Berman patent 3,753,059 shows a control circuit for a motor operated in both propulsive and regenerative modes, as might be employed in the hybrid vehicle drive system of Berman patent 3,566,717, already of record. Berman 3,790,816 shows an "energy storage and transfer power processor" apparently intended for use with the same system.

Williams 4,099,589 shows a series hybrid wherein the preferred power path is from an ICE to an AC generator to an AC motor, to the wheels; a rectifier, battery and DC motor are also provided as an auxiliary or additional power source.

Rowlett 4,233,858 shows a vehicle propulsion system wherein two electric motors are provided. Torque from the two motors is combined; excess torque is stored in a flywheel, to provide load-leveling.

Dailey 4,287,792 shows a variable gear ratio transmission.

Fiala 4,411,171 shows a hybrid vehicle power train in which a single electric motor/generator and an ICE are coupled to the wheels of the vehicle. Various operating modes are described.

Tankersley et al patent 5,403,244 shows an electric vehicle with a planetary gearbox for reducing the shaft speed of an electric motor to a speed suitable for driving the wheels of the vehicle, and also providing a direct drive.

Hadley et al 5,406,126 shows another serial hybrid. The invention appears to have to do with the method of regenerative charging offered.

Westphal patent 5,570,615 shows a three-mass flywheel construction, with two of the masses connected by springs and the third by planetary gears for balancing of various moments and vibrations.

Nedungadi patent 6,110,066 shows a hybrid vehicle operating in four modes, as follows (col. 4, lines 25 - 38): "There are four modes of operation for the vehicle, namely: (a) electric; (b) charge; (c) assist; and, (d) regenerative. In the electric mode, only the motor is providing propulsion power to the vehicle. In the charge mode, part of the engine power drives the vehicle and the rest is absorbed by the motor (operating as a generator) to charge the batteries. In the assist mode, both the engine and the motor are providing power to propel the vehicle. In the regenerative mode, power from the decelerating wheels is diverted to the motor so that it can be used to charge the batteries. .... The controller selects the most appropriate mode depending upon the position of the accelerator pedal, the vehicle speed and the state of charge of the battery." Nedungadi makes it clear that the idea is to keep the engine "as loaded as possible" (col. 8, line 46). In assist mode, this is done by keeping the engine at maximum power; in the charge mode, the engine is maintained at its point of maximum fuel efficiency. See col. 5, lines 46 - 53.

Fini patent 6,387,007 shows several embodiments of hybrids. Mode control appears to be accomplished responsive to accelerator pedal position.

Tsai et al 6,592,484 shows a hybrid comprising an ICE and a single motor as prime movers. The invention is directed to a



transmission including four clutches and two planetary gearsets. Some 13 operating modes are stated to be provided.

Horwinski patent 3,904,883 is essentially a predecessor of the Horwinski patent already of record.

Yamada patent 6,041,877 was recently cited in an Office Action issued against a Japanese application based on a PCT application with disclosure corresponding to the disclosures of the two parent applications. According to a non-certified translation of the Office Action, Yamada was cited because it shows "a hybrid vehicle in which a battery is configured as two separate battery sub-banks"; this was cited against a claim not corresponding to any now in this application, including a similar recitation. (Claim 29 of issued patent 6,209,672 includes a comparable limitation.) The disclosure of Yamada otherwise seems merely cumulative to numerous references of record. Japanese Utility Model Application No. 50-099456 (provided with a translated summary sheet only) was also cited in the same Office Action, the Japanese Examiner stating that "there is described a technology in which two battery groups in an electrically driven vehicle (B1 and B2, B4 and B3) are connected in series and the middle of the two battery groups is earthed to a vehicle chassis." Again, this is not relevant to any claim now being asserted herein.

Tabata patent 5,887,670 shows a single-motor hybrid. Mode determination is accomplished (see Fig. 7) responsive to a "currently required output Pd" which is determined responsive to pedal position, rate of change thereof, vehicle speed and transmission lever position (see col. 23, lines 20 - 26).

Otsu et al patent 6,123,163 shows a single-motor hybrid configured as a sort of city scooter. The vehicle operates in different modes depending on the "aimed" torque, which is determined responsive to accelerator opening and vehicle speed.

See Fig. 13, col. 10, lines 56 - 67 and col. 17, lines 11 - 33. Otsu 6,260,644 seems to have the same disclosure, and Suzuki 6,253,865 to relate to the same design.

Arai patent 6,435,296 shows a hybrid with an engine driving one set of wheels and a motor driving the other. In order that a DC motor can be used, avoiding the expense of an inverter, the motor is to be used as little as possible.

Sherman 5,789,823 shows both a torque converter and a friction clutch in a single motor hybrid. This is essentially an engine-assist arrangement; the engine can only be started when the vehicle transmission is in neutral (see col. 3, lines 30 - 38), so that it must be run at all times, and the motor/generator is stated to only assist the engine during times of peak power requirement (col. 4, lines 36 - 38). Another Sherman patent 5,258,651 is not directed to hybrid vehicles, but to a system for starting an ICE.

Onimaru 6,007,443 (Nippon Soken) shows a hybrid wherein an ICE is connected through a CVT and a clutch to a motor/generator, the output shaft of which drives the wheels. Above a minimum velocity, the engine is operated at a maximum speed. See col. 7, line 17. At lower vehicle speeds, the engine is permitted to idle; see col. 6, lines 9 - 23.

Ehsani et al, in "Propulsion System Design of Electric and Hybrid Vehicles", discuss determination of the sizes and capacities of an ICE and traction motor for a hybrid vehicle. This is generally relevant to the subject matter of claims 16 and 112. However, note that Ehsani fails entirely to address the relationship claimed between the voltage and current of the battery bank, as claimed. Ehsani et al, in "Parametric Design of the Drive Train of an Electrically Peaking Hybrid (ELPH) Vehicle", go into further detail, and indicate that the vehicle of concern is a single-motor hybrid wherein torque from the ICE

and motor can be combined by a "matchgear", as in applicant's prior patent 5,343,970. Ehsani patent 5,586,613, apparently directed to the same work, is discussed in the application as filed.

Yamaguchi et al, "Development of a New Hybrid System - Dual System", SAE paper 960231 (1996) appears to be merely cumulative to numerous patents to the same inventors already of record. "Dual System - Newly Developed Hybrid System" (publication details not known), by some of the same authors, of which only a partial copy is available, is generally cumulative but does provide a diagram showing operation of the various components as a function of time

Takaoka et al, in "A High-Expansion-Ratio Gasoline Engine for the Toyota Hybrid System", discuss the details of an ICE designed for use in a hybrid vehicle. This paper states that "By using the supplementary drive power of the electric motor, the system eliminates the light-load range, where concentrations of hydrocarbons in the emissions are high and the exhaust temperature is low." (p. 57; a similar statement is made on p. 59) and "By allocating a portion of the load to the electric motor, the system is able to reduce engine load fluctuation under conditions such as rapid acceleration. This makes it possible to reduce quick transients in engine load so that the air-fuel ratio can be stabilized easily." (p. 58). The former statement simply emphasizes the fact that engines are operated more efficiently at higher loads, and the latter that stoichiometric combustion can be more nearly obtained if the engine's speed and/or load is varied as slowly as possible.

Sasaki et al, "Toyota's Newly Developed Electric-Gasoline Hybrid Powertrain System" (publication data not available) provides a mathematical analysis of the planetary gearbox.

PCT application PCT/SE81/00280, published as WO 82/01170, shows a hybrid vehicle wherein an ICE is used for propulsion under some circumstances and an electric motor under others, e.g., to provide a forklift truck that operates electrically when indoors and is driven by the ICE when outdoors. The change from one torque source to the other is made as a function of vehicle speed. See p. 3, lines 19 - 28.

Japanese utility model publication 53-55105 (of which only a partial translation is available) appears to show a hybrid vehicle having both an ICE and a motor as sources of propulsive torque, but the description provided is inadequate to understand how the two sources are to be operated. The disclosure of Japanese patent application publication 48-64626 (of which only a partial translation is available) seems to be similar.

Japanese unexamined patent application publication 4-67703 (of which only a partial translation is available) appears to relate to an electric vehicle.

Japanese patent application publication 4-297330 (of which only a partial translation is available) seems to relate to supplementing the regenerative braking available using a traction motor as the source of braking torque with regenerative braking from a generator attached to an ICE, and with friction from motoring the engine under braking.

Japanese patent application publication 55-110328 (of which only a partial translation is available) relate to a vehicle wherein a first pair of wheels is driven by a "main driving unit", a second pair being driven by an "auxiliary power unit", wherein the auxiliary power unit is controlled responsive to a difference in speed between the first and second pairs of wheels.

Japanese utility model publication 51-103220 (of which only a partial translation is available) describes a control system for a hybrid wherein the output shaft of an ICE is connected to

that of an electric motor through a clutch, the clutch being controlled to operate when speed sensors on the shafts indicate that their rotational speeds are equal.

Japanese patent 49-29642 (of which only a partial translation is available) also shows a hybrid wherein the shaft of an ICE is connected by a clutch to that of an electric motor; in this case a one-way clutch is also provided.

Japanese patent publication 6-245317 (of which only a partial translation is available) relates to a device for preventing overcharging of the battery of an electric vehicle.

European patent application publication no. 510 582 shows a vehicle powerplant featuring both an ICE and an electric motor as sources of propulsion, and thus a hybrid of sorts, though the term is not mentioned. No suggestion is made that the control of operating mode is made other than by an operator; the determining factor seems to be whether emission must be completely prohibited, as in indoor operation.

European patent application publication no. 510 582 also shows a hybrid vehicle featuring both an ICE and an electric motor as sources of propulsion. Again there is no teaching of the specifics of switching operating mode; the invention has to do with loading the ICE by means of the generator so as to match the speed of the engine to the speed of a drive shaft driven by the traction motor before engaging a clutch connecting the two.

German OS 25 17 110, provided with an English-language abstract, is stated by the abstract to show a hybrid vehicle with a turbine engine. It appears that the vehicle is operated as an electric car until the current drawn exceeds a preset value, when the turbine is actuated; thereafter, the turbine is run at an "optimum setting", with the load split between battery charging and vehicle propulsion.

Mayrhofer et al, "A Hybrid Drive Based on a Structure Variable Arrangement" (1994), shows a hybrid vehicle design involving an ICE, two motor/generators, a planetary gearbox to enable combinations of sources of torque, and no less than four clutches, obviously much more complicated than would be desirable. Of interest with respect to the present invention is that in one operating strategy (see page 196) Mayrhofer et al suggest that the ICE should be activated only when the mean value of the power demanded exceeds a limit for more than a minimum time, 20 seconds being the example given. It is apparent that the ICE is thus to be used only for load-leveling and that mode changes are not being made based on the road load *per se*. In other strategies the engine operation appears to be even further afield from applicants' simple and direct strategy.

A December 1990 *Popular Science* article, "Diesel-Electric VW", describes a hybrid wherein an electric motor, also serving a generator and engine starter, is disposed between clutches connecting the motor to an ICE on one side and the vehicle wheels on the other. It is not clear what modes are provided, although some transitions are apparently made responsive to accelerator pedal position and vehicle velocity.

A May 1991 *Popular Science* article, "Electric Vehicles Only", addresses the then-current state of the art in electric vehicles and mentions hybrids only peripherally.

An April 1991 article appearing in *NASA Tech Briefs* discusses lead/acid batteries having woven electrodes.

As indicated, none of the newly-cited patents made of record hereby disclose or suggest the invention claimed herein. Early and favorable action on the merits of the application is earnestly solicited.

Respectfully submitted,

*May 17, 2004*  
Dated

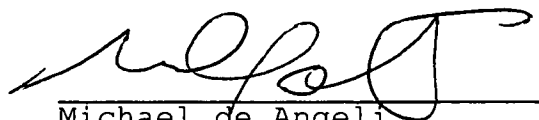

Michael de Angeli  
Reg. No. 27,869  
60 Intrepid Lane  
Jamestown, RI 02835  
401-423-3190

MAY 20 2006  
 PATENT & TRADEMARK OFFICE

OIPE 1AP87  
 JUL 07 2006  
 PATENT & TRADEMARK OFFICE

1 of 12

INFORMATION DISCLOSURE CITATION  
 IN AN APPLICATION

NUMBER PAICE201.DIV APPLICATION NUMBER 10/382,577

APPLICANT Severinsky et al

FILING DATE 3/7/2003 CLASS ART UNIT 3616

U.S. PATENT DOCUMENTS

EXAMINER INITIAL	DOCUMENT NUMBER	DATE	NAME	CLASS	SUBCLASS	FILING DATE
DD	6 2 8 1 6 6 0	08/2001	Abe			
	<del>5 5 1 5 9 3 7 5</del>	<del>5/1996</del>	<del>Adler et al</del>			
DD	5 3 3 6 9 3 2 4	4/1994	Barske			
DD	6 1 7 0 5 8 7 1	1/2001	Bullock			
DD	5 8 8 7 6 7 4 3	3/1999	Gray			
DD	4 7 6 2 1 9 1 8	8/88	Hagin et al			
	6 3 1 5 0 6 8 1 1	11/2001	Hoshiya et al			
DD	5 8 5 6 7 0 9 1	1/1999	Ibaraki et al			
DD	6 2 0 4 6 3 6 3	6/2001	Kinoshita et al			
DD	6 2 2 5 7 8 4 5	5/2001	Kinoshita et al			
DD	6 2 3 2 7 4 8 5	5/2001	Kinoshita et al			
	6 0 1 9 6 9 8 2	2/2000	Lawrie			

RECEIVED  
 JUN 02 2004  
 GROUP 3600

FOREIGN PATENT DOCUMENTS

DOCUMENT NUMBER	DATE	COUNTRY	CLASS	SUBCLASS	TRANSLATION	
					YES	NO

OTHER DOCUMENTS (Including Author, Title, Date, Pertinent Pages, Etc)

EXAMINER *[Signature]* DATE CONSIDERED 6/24/04

EXAMINER: Initial if citation considered, whether or not citation is in conformance with MPEP § 609; Draw line through citation if not in conformance and not considered. Include copy of this form with next communication to the applicant.



PATENT & TRADEMARK O

INFORMATION DISCLOSURE CITATION IN AN APPLICATION	DOCKET NUMBER	PAICE201.DIV	APPLICATION NUMBER	10/382,577
	APPLICANT	Severinsky et al		
	FILING DATE	3/7/2003	GROUP ART UNIT	3616

U.S. PATENT DOCUMENTS

EXAMINER INITIAL	DOCUMENT NUMBER	DATE	NAME	CLASS	SUBCLASS	FILING DATE
	5 9 9 3 3 5 0	11/1999	Lawrie et al			
	5 9 7 9 2 5 7	11/1999	Lawrie			
	6 0 0 6 5 2 0	12/1999	Lawrie et al			
DD	6 2 9 1 9 5 3	9/2001	Lovatt et al			
DD	6 3 3 2 2 5 7	12/2001	Reed Jr. et al			
DD	5 9 4 3 9 1 8	8/1999	Reed Jr. et al			
	5 7 5 5 3 0 2	5/1998	Lutz et al			on page 10
DD	6 1 4 2 9 0 7	11/2000	Minowa			
DD	6 3 2 8 6 7 0	12/2001	Minowa			
DD	6 1 1 9 7 9 9	9/2000	Morisawa			
DD	5 9 8 4 0 3 4	11/1999	Morisawa			
DD	6 3 3 4 4 9 8	1/2002	Morisawa			

RECEIVED  
JUN 02 2004  
GROUP 3600  
permanently cited

FOREIGN PATENT DOCUMENTS

DOCUMENT NUMBER	DATE	COUNTRY	CLASS	SUBCLASS	TRANSLATION	
					YES	NO

OTHER DOCUMENTS (Including Author, Title, Date, Pertinent Pages, Etc)

EXAMINER *[Signature]* DATE CONSIDERED 11/24/07

EXAMINER: Initial if citation considered, whether or not citation is in conformance with MPEP §609; Draw line through citation if not in conformance and not considered. Include copy of this form with next communication to the applicant.



INFORMATION DISCLOSURE CITATION IN AN APPLICATION	DOCKET NUMBER	PAICE201.DIV	APPLICATION NUMBER	10/382,577
	APPLICANT			
	FILING DATE 3/1/2003		GROUP ART UNIT	

U.S. PATENT DOCUMENTS

EXAMINER INITIAL	DOCUMENT NUMBER	DATE	NAME	CLASS	SUBCLASS	FILING DATE
DD	5 8 9 5 3 3 3 4	1999	Morisawa			
DD	6 3 0 6 0 5 7 10	2001	Morisawa			
DD	6 3 4 4 0 0 8 2	2002	Nagano			
DD	6 0 9 0 0 0 7 7	2000	Nakajima			
DD	6 3 2 8 6 7 1 12	2001	Nakajima			
DD	5 6 6 0 0 7 7 8	1997	Nekola			
DD	6 2 0 3 4 6 8 3	2001	Nitta			
DD	6 3 2 1 1 5 0 11	2001	Nitta			
DD	5 9 4 4 6 3 0 8	1999	Omote			
DD	6 0 7 0 6 8 0 6	2000	Oyama			
DD	6 1 2 3 6 4 2 9	2000	Saito			
DD	6 1 5 8 5 4 1 12	2000	Tabata			

RECEIVED  
JUN 02 2004  
GROUP 5600

FOREIGN PATENT DOCUMENTS

DOCUMENT NUMBER	DATE	COUNTRY	CLASS	SUBCLASS	TRANSLATION	
					YES	NO

OTHER DOCUMENTS (Including Author, Title, Date, Pertinent Pages, Etc)

DD	Published application US 2001/0037905, of Nogi et al., <del>11/2001</del> 11/2001

EXAMINER: *[Signature]* DATE CONSIDERED: 11/29/04

EXAMINER: Initial if citation considered, whether or not citation is in conformance with MPEP § 609; Draw line through citation if not in conformance and not considered. Include copy of this form with next communication to the applicant.



INFORMATION DISCLOSURE CITATION IN AN APPLICATION	DOCKET NUMBER	PAICE201.DIV	APPLICATION NUMBER	10/382,577
	APPLICANT	Severinsky et al		
	FILING DATE	3/7/2003	GROUP ART UNIT	3616

U.S. PATENT DOCUMENTS

EXAMINER INITIAL	DOCUMENT NUMBER	DATE	TITLE	CLASS	SUBCLASS	FILING DATE
DD	5 8 4 7 4 6 9	12/1998	Tabata			
DD	6 3 1 7 6 6 5	11/2001	Tabata			
DD	6 1 8 3 3 8 9	2/2001	Tabata			
DD	5 8 7 3 4 2 6	2/1999	Tabata			
DD	5 9 2 3 0 9 3	7/1999	Tabata			
DD	6 3 4 0 3 3 9	1/2002	Tabata			
DD	5 9 3 5 0 4 0	8/1999	Tabata et al.			
DD	5 4 1 5 6 0 3	5/1995	Tuzuki et al			
DD	6 2 5 8 0 0 1	6/2001	Wakuta			
DD	5 8 9 0 4 7 0	4/1999	Woon			
DD	6 3 2 8 1 2 2	12/2001	Yamada			
DD	6 2 7 8 1 9 5	8/2001	Yamaguchi et al			

RECEIVED  
JUN 02 2004  
GROUP 6600

FOREIGN PATENT DOCUMENTS

	DOCUMENT NUMBER	DATE	COUNTRY	CLASS	SUBCLASS	TRANSLATION	
						YES	NO
DD	4 8 6 4 6 2 6	9/1973	Japan				part.
DD	4 9 2 9 6 4 2	8/1974	Japan				"

OTHER DOCUMENTS (Including Author, Title, Date, Pertinent Pages, Etc)

DD	Published patent application US 2003/0085577 of Takaoka et al, May 8, 2003

EXAMINER: *[Signature]* DATE CONSIDERED: 11/29/04

EXAMINER: Initial if citation considered, whether or not citation is in conformance with MPEP §609; Draw line through citation if not in conformance and not considered. Include copy of this form with next communication to the applicant.



INFORMATION DISCLOSURE CITATION IN AN APPLICATION	DOCKET NUMBER	PAICE201.DIV	APPLICATION NUMBER	10/382,577	
	APPLICANT				
	FILING DATE		CLASS ART UNIT		
		3/7/2003		3616	

U.S. PATENT DOCUMENTS

EXAMINER INITIAL	DOCUMENT NUMBER	DATE	NAME	CLASS	SUBCLASS	FILING DATE
DD	6 2 4 7 4 3 7	6/2001	Yamaguchi et al			
DD	5 9 6 7 9 4 0	10/1999	Yamaguchi et al			
DD	5 0 8 1 3 6 5	1/1992	Field et al			
DD	6 0 4 4 9 2 2	4/2000	Field			
DD	6 4 8 1 5 1 6	11/2002	Field et al			
	3 7 1 9 8 8 1	3/1971	Shibata et al			
DD	4 1 8 7 4 3 6	2/1980	Etienne			
DD	5 7 2 2 5 0 2	3/1998	Kubo			
DD	6 2 3 1 1 3 5	5/2001	Bower et al			
DD	6 3 5 7 5 4 1	3/2002	Matsuda et al			
DD	6 2 6 5 6 9 2	7/2001	Umebayahi et al			
DD	5 4 9 7 9 4 1	3/1996	Numazawa et al			

RECEIVED  
JUN 02 2004  
GROUP 5000

Cited on pg 10

FOREIGN PATENT DOCUMENTS

	DOCUMENT NUMBER	DATE	COUNTRY	CLASS	SUBCLASS	TRANSLATION	
						YES	NO
DD	5 3 5 5 1 0 5	05/1978	Japan				part
DD	4 6 7 7 0 3	3/1992	Japan				"
DD	6 2 4 5 3 1 7	2/1993	Japan				"
DD	4 2 9 7 3 3 0	10/1992	Japan				"
DD	51 1 0 3 2 2 0	8/1976	Japan				"

OTHER DOCUMENTS (Including Author, Title, Date, Pertinent Pages, Etc)

DD	Mayrhofer et al "A Hybrid Drive Based on a Structure Variable Arrangement" (1994)

EXAMINER: *[Signature]* DATE CONSIDERED: 11/23/04

EXAMINER: Initial if citation considered, whether or not citation is in conformance with MPEP § 609; Draw line through citation if not in conformance and not considered. Include copy of this form with next communication to the applicant.



INFORMATION DISCLOSURE CITATION IN AN APPLICATION	DOCKET NUMBER	PAICE201.DIV	APPLICATION NUMBER	10/382,577
	APPLICANT	Severinsky et al		
	FILING DATE	3/7/2003	GROUP ART UNIT	3616

U.S. PATENT DOCUMENTS

EXAMINER INITIAL	DOCUMENT NUMBER	DATE	NAME	CLASS	SUBCLASS	FILING DATE
DD	6 0 6 4 1 6 1	5/2000	Takahara			
DD	5 5 6 2 5 6 6	10/1996	Yang			
DD	5 2 1 2 4 3 1	5/1993	Origuchi et al			
	4 1 6 5 7 9 5	8/1979	Lynch et al			
DD	5 2 8 3 4 7 0	2/1994	Hadley et al			
DD	5 4 0 6 1 2 6	8/1995	Hadley et al			
DD	5 6 6 9 8 4 2	9/1997	Schmidt			
DD	5 7 7 1 4 7 8	6/1998	Tsukamoto			
DD	5 8 3 3 5 7 0	11/1998	Tabata			
DD	5 9 5 1 6 1 4	9/1999	Tabata			
DD	5 8 7 5 6 9 1	3/1999	Hata			
DD	5 9 3 1 2 7 1	8/1999	Haka			

RECEIVED  
JUN 02 2004  
GROUP 3600

Previously cited

FOREIGN PATENT DOCUMENTS

	DOCUMENT NUMBER	DATE	COUNTRY	CLASS	SUBCLASS	TRANSLATION	
						YES	NO
DD	5 1 0 5 8 2	10/1992	European Patent Office				
DD	1 3 6 0 5 5	3/1985	European Patent Office				
DD	2 5 1 7 1 1 0	10/1975	German				
DD	8 2 0 1 1 7 0	4/1982	PCT/SE81/00280				
DD	55 1 1 0 3 2 8	8/1980	Japan				part

OTHER DOCUMENTS (Including Author, Title, Date, Pertinent Pages, Etc)

DD	"Diesel-Electric VW", <i>Popular Science</i> , December 1990, p. 30.
DD	"Electric Vehicles Only", <i>Popular Science</i> , May 1991, pp. 76-81 and 110.
DD	"Lightweight, High-Energy Lead/Acid Battery" <i>NASA Tech Briefs</i> , 4/91, 22-24.

EXAMINER: DATE CONSIDERED: 11/29/04

EXAMINER: Initial if citation considered, whether or not citation is in conformance with MPEP §609; Draw line through citation if not in conformance and not considered. Include copy of this form with next communication to the applicant.



INFORMATION DISCLOSURE CITATION IN AN APPLICATION	DOCKET NUMBER	PAICE201.DIV	APPLICATION NUMBER	10/382,577
	APPLICANT	Severinsky et al		
	FILING DATE 3/7/2003	EXHIBIT ART UNIT	3616	

U.S. PATENT DOCUMENTS

EXAMINER INITIAL	DOCUMENT NUMBER	DATE	NAME	CLASS	SUBCLASS	FILING DATE
DD	5 9 5 1 1 1 8	9/1999	Soejima			
DD	5 9 8 4 4 3 2	11/1999	Otomo et al			
DI	5 9 7 9 1 5 8	11/1999	Kaiser			
DD	5 9 8 3 7 4 0	11/1999	Salecker et al			
DD	6 0 0 6 1 4 9	12/1999	Salecker et al			
DD	6 0 0 3 6 2 6	12/1999	Ibaraki et al			
DD	6 0 0 9 3 6 5	12/1999	Takahara et al			
DD	4 1 2 6 2 0 0	11/1978	Miller et al			
DD	4 0 9 0 5 7 7	5/1978	Moore			
DD	5 3 2 3 6 8 8	6/1994	Walker			
DI	5 3 8 4 5 2 1	1/1995	Coe			
DD	5 6 2 3 1 9 4	4/1997	Boll			

RECEIVED  
JUN 02 2004  
GROUP 6000

FOREIGN PATENT DOCUMENTS

DOCUMENT NUMBER	DATE	COUNTRY	CLASS	SUBCLASS	TRANSLATION	
					YES	NO

OTHER DOCUMENTS (Including Author, Title, Date, Pertinent Pages, Etc)

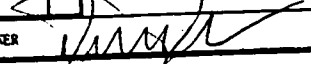
EXAMINER  DATE CONSIDERED 11/29/09

EXAMINER: Initial if citation considered, whether or not citation is in conformance with MPEP § 609; Draw line through citation if not in conformance and not considered. Include copy of this form with next communication to the applicant.



INFORMATION DISCLOSURE CITATION  
IN AN APPLICATION

DOCKET NUMBER PAICE201.DIV APPLICATION NUMBER 10/382,577  
 APPLICANT Severinsky et al  
 FILING DATE 3/7/03 GROUP ART UNIT 3616

U. S. PATENT DOCUMENTS

EXAMINER INITIAL	DOCUMENT NUMBER	DATE	NAME	CLASS	SUBCLASS	FILING DATE
DD	5 6 7 5 2 0 3	10/1997	Schulze et al			
DD	5 6 7 5 2 2 2	10/1997	Fliege			
DD	5 6 7 9 0 8 7	10/1997	Lutz			
DD	5 6 8 5 7 9 8	11/1997	Lutz			
DD	5 6 9 1 5 8 8	11/1997	Lutz			
DD	5 6 9 8 9 0 5	12/1997	Ruthlein et al			
DD	5 7 1 3 4 2 7	2/1998	Lutz			
DD	5 7 1 4 8 5 1	2/1998	Antony et al			
DD	5 8 5 6 0 4 7	1/1999	Venkatesan et al			
DD	5 8 5 1 6 9 8	12/1998	Reichmann et al			
DD	4 2 1 6 6 8 4	8/1980	Hagin et al			
DD	4 3 3 1 9 1 1	5/1982	Park			

RECEIVED  
 JUN 02 2004  
 GROUP 6600

FOREIGN PATENT DOCUMENTS

DOCUMENT NUMBER	DATE	COUNTRY	CLASS	SUBCLASS	TRANSLATION	
					YES	NO

OTHER DOCUMENTS (Including Author, Title, Date, Pertinent Pages, Etc)

EXAMINER *[Signature]* DATE CONSIDERED 4/29/04

EXAMINER: Initial if citation considered, whether or not citation is in conformance with MPEP § 609; Draw line through citation if not in conformance and not considered. Include copy of this form with next communication to the applicant.



<b>INFORMATION DISCLOSURE CITATION IN AN APPLICATION</b>	DOCKET NUMBER	PAICE201.DIV	APPLICATION NUMBER	10/382,577
	APPLICANT			
	FILING DATE 3/7/03		GROUP ART UNIT	

**U. S. PATENT DOCUMENTS**

EXAMINER INITIAL	DOCUMENT NUMBER	DATE	NAME	CLASS	SUBCLASS	FILING DATE
DD	4 4 1 6 3 6 0	11/1983	Fiala			
DD	4 5 9 1 0 1 6 5	5/1986	Matthews			
DD	4 5 9 2 4 5 4 6	6/1986	Michel			
DD	4 6 7 4 2 8 0 6	6/1987	Stuhr			
DD	4 7 5 3 0 7 8 6	6/1988	Gardner			
DD	5 0 0 0 0 0 3 3	3/1991	Wicks			
DD	5 1 4 1 1 7 3 8	8/1992	Lay			
DD	5 2 4 2 3 3 5 9	9/1993	Kutter			
DD	5 2 6 4 7 6 4 11	11/1993	Kuang			
DD	5 9 1 5 4 8 8 6	6/1999	Fliege			
DD	5 9 4 7 8 5 5 9	9/1999	Weiss			
DD	5 9 7 1 0 8 8 10	10/1999	Smith			

RECEIVED  
JUN 02 2004  
GROUP 3600

**FOREIGN PATENT DOCUMENTS**

DOCUMENT NUMBER	DATE	COUNTRY	CLASS	SUBCLASS	TRANSLATION	
					YES	NO

**OTHER DOCUMENTS** (Including Author, Title, Date, Pertinent Pages, Etc)

EXAMINER <i>[Signature]</i>	DATE CONSIDERED <i>11/29/04</i>	<small>EXAMINER: Initial if citation considered, whether or not citation is in conformance with MPEP §609; Draw line through citation if not in conformance and not considered. Include copy of this form with next communication to the applicant.</small>
-----------------------------	---------------------------------	---





<b>INFORMATION DISCLOSURE CITATION IN AN APPLICATION</b>	DOCKET NUMBER	PAICE201.DIV	APPLICATION NUMBER	10/382,577
	APPLICANT			
	FILING DATE 3/7/03		GROUP ART UNIT	

**U.S. PATENT DOCUMENTS**

EXAMINER INITIAL	DOCUMENT NUMBER	DATE	NAME	CLASS	SUBCLASS	FILING DATE
DD	5 9 7 1 0 9 2	10/1999	Walker			
DD	5 7 5 5 3 0 2	5/1998	Lutz			
DD	5 6 7 8 6 4 6	10/1997	Fliege			
	5 8 3 3 0 2 2	11/1998	Welke			
DD	5 8 1 6 3 5 8	10/1998	Adler et al			
DD	3 6 9 9 3 5 1	10/1972	Addie			
DD	3 7 1 9 8 8 1	3/1973	Shibata et al			
DD	3 7 5 3 0 5 9	8/1973	Berman			
DD	3 7 9 0 8 1 6	2/1974	Berman			
DD	4 0 9 9 5 8 9	7/1978	Williams			
DD	4 2 3 3 8 5 8	11/1980	Rowlett			
DD	4 2 8 7 7 9 2	9/1981	Dailey			

RECEIVED

JUN 02 2004

GROUP 5000

prev cited

**FOREIGN PATENT DOCUMENTS**

DOCUMENT NUMBER	DATE	COUNTRY	CLASS	SUBCLASS	TRANSLATION	
					YES	NO

**OTHER DOCUMENTS** (including Author, Title, Date, Pertinent Pages, Etc)

EXAMINER <i>[Signature]</i>	DATE CONSIDERED	11/29/04
-----------------------------	-----------------	----------

EXAMINER: Initial if citation considered, whether or not citation is in conformance with MPEP § 609; Draw line through citation if not in conformance and not considered. Include copy of this form with next communication to the applicant.



INFORMATION DISCLOSURE CITATION IN AN APPLICATION	DOCKET NUMBER PAICE201.DIV	APPLICATION NUMBER 10/382,577
	APPLICANT Severinsky et al	
	FILED DATE 3/7/03	GROUP PAY UNIT 3616

U.S. PATENT DOCUMENTS

EXAMINER INITIAL	DOCUMENT NUMBER	DATE	NAME	CLASS	SUBCLAS	FILING DATE
DD	4 4 1 1 1 7 1	10/1983	Fiala			
DD	5 4 0 3 2 4 4	4/1995	Tankersley			
	5 4 0 6 1 2 6	4/1995	Hadley et al			
DD	5 5 4 9 5 2 4	8/1996	Yang			
DD	5 5 4 7 4 3 3	8/1996	Yang			
DD	5 5 7 0 6 1 5	11/1996	Westphal et al			
DD	5 9 1 5 4 8 9	6/1999	Yamaguchi			
DD	6 1 1 0 0 6 6	8/2000	Nedungadi et al			
DD	6 1 3 5 9 1 4	10/2000	Yamaguchi et al			
DD	6 3 8 7 0 0 7	5/2002	Fini			
DD	6 5 6 3 2 3 0	5/2003	Nada			
DD	6 5 9 2 4 8 4	7/2003	Tsai			

RECEIVED

JUN 02 2004

GROUP 5600

Cited on pg 6

FOREIGN PATENT DOCUMENTS

DOCUMENT NUMBER	DATE	COUNTRY	CLASS	SUBCLASS	TRANSLATION	
					YES	NO

OTHER DOCUMENTS (Including Author, Title, Date, Pertinent Pages, Etc)

DD	Yamaguchi et al, "Dual System - Newly Developed Hybrid System" (incomplete)
DD	Takaoka et al "A High-Expansion-Ratio Gasoline Engine for the Toyota Hybrid System", Toyota Technical Review <del>47, 2, 1998</del> Vol. 47, No. 2, April 1998.
DD	Sasaki et al, "Toyota's Newly Developed Electric-Gasoline Hybrid Powertrain System" (publication data not available)

EXAMINER: *[Signature]* DATE CONSIDERED: 11/29/04

EXAMINER: Initial if citation considered, whether or not citation is in conformance with MPEP §609; Draw line through citation if not in conformance and not considered. Include copy of this form with next communication to the applicant.



<b>INFORMATION DISCLOSURE CITATION IN AN APPLICATION</b>	DOCKET NUMBER	PAICE201.DIV	APPLICATION NUMBER	10/382,577
	APPLICANT	Severinsky et al		
	FILING DATE	3/7/03	GROUP ART UNIT	3616

**U.S. PATENT DOCUMENTS**

EXAMINER INITIAL	DOCUMENT NUMBER	DATE	NAME	CLASS	SUBCLAS	FILING DATE
DD	3 9 0 4 8 8 3	9/1975	Horwinski			
DD	6 0 4 1 8 7 7	3/2000	Yamada et al			
	<del>5 8 8 7 6 7 0</del>	<del>3/1999</del>	<del>Tabata et al</del>			
DD	6 1 2 3 1 6 3	9/2000	Otsu et al			
DD	6 2 6 0 6 4 4	7/2001	Otsu			
DD	6 2 5 3 8 6 5	7/2001	Suzuki			
DD	6 4 3 5 2 9 6	8/2002	Arai			
DD	5 2 5 8 6 5 1	11/1993	Sherman			
DD	5 7 8 9 8 2 3	8/1998	Sherman			
DD	6 0 0 7 4 4 3	12/1999	Onimaru			

RECEIVED

JUN 02 2004

prev. cited

GROUP 3600

**FOREIGN PATENT DOCUMENTS**

DOCUMENT NUMBER	DATE	COUNTRY	CLASS	SUBCLASS	TRANSLATION	
					YES	NO
50 0 9 9 4 5 6	1/1977	Japan				NO

**OTHER DOCUMENTS** (Including Author, Title, Date, Pertinent Pages, Etc)

DD	Ehsani et al "Propulsion System Design of Electric and Hybrid Vehicles", IEEE Trans. Ind. Elec., 44 1 (1997)
DD	Ehsani et al, "Parametric Design of the Drive Train of an Electrically Peaking Hybrid (ELPH) Vehicle", SAE paper 970294 (1997)
DD	Yamaguchi et al, "Development of a New Hybrid System - Dual System", SAE papers 960231 (1996)

EXAMINER: *[Signature]* DATE CONSIDERED: 11/29/04

EXAMINER: Initial if citation considered, whether or not citation is in conformance with MPEP §609: Draw line through citation if not in conformance and not considered. Include copy of this form with next communication to the applicant.



IN THE UNITED STATES PATENT AND TRADEMARK OFFICE

In re the Patent Application of :  
Severinsky et al : Examiner: N/A  
Serial No.: N/A : Group Art Unit: N/A  
Filed: Herewith : Att. Dkt.: PAICE201.DIV  
For: HYBRID VEHICLES :

Hon. Commissioner of Patents and Trademarks  
Washington, DC 20231

**INFORMATION DISCLOSURE STATEMENT**

Dear Sir:

This application is a divisional of Ser. No. 09/822,866. Incorporated herein by this reference are the original and three supplemental Information Disclosure Statements filed in the parent, copies of which are enclosed herewith. These, together with an Examiner's Notice of References Cited, a copy of which is also enclosed, collectively list all of the art deemed relevant to the claims of the application. Copies of the references were provided in the parent or in the applications from which it in turn claimed priority and thus are not being provided herewith. The Examiner is requested to indicate that all of the art thus listed has been considered.

Early and favorable action on the merits is earnestly solicited.

Respectfully submitted,

Michael de Angeli  
Reg. No. 27,869  
60 Intrepid Lane  
Jamestown, RI 02835  
401-423-3190

3/5/03  
Dated

**BEST AVAILABLE COPY**

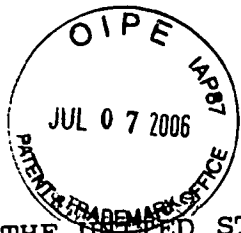

IN THE UNITED STATES PATENT AND TRADEMARK OFFICE

In re the Patent Application of	:
Severinsky et al	:
Serial No.: 09/822,866	: Examiner: N/A
Filed: April 2, 2001	: Group Art Unit: N/A
	: Att. Dkt.: PAICE201
For: Hybrid Vehicles	:

Hon. Commissioner of Patents and Trademarks  
Washington, DC 20231

**INFORMATION DISCLOSURE STATEMENT**

Dear Sir:

Listed on attached PTO-1449 forms are the issued patents and literature references considered to be most relevant to the patentability of the claims of this application. Copies of the patents listed on page 15 of the PTO-1449 are attached for the convenience of the Examiner, as is a copy of German patent 1,905,641, with uncertified translation. Copies of the other listed references were provided to the Examiner in connection with one or both of patent applications 09/264,817 and 09/392,743, so additional copies are not being submitted herewith.

Comments on the relevance of the new references which are material to the claims of this continuation-in-part per se are found in the application as filed, while the comments on these references found in the prosecution files of the two parent applications are also incorporated by reference herein.

Early and favorable action on the merits is earnestly solicited.

5/21/01  
Dated

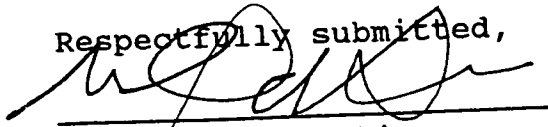
Respectfully submitted,  
  
Michael de Angeli  
Reg. No. 27,869  
Suite 330  
1901 Research Blvd.  
Rockville, MD 20850  
(301) 217-9585



**INFORMATION DISCLOSURE CITATION  
IN AN APPLICATION**

DOCKET NUMBER: PAICE201 APPLICATION NUMBER: 09/822,866  
 APPLICANT: Severinsky et al  
 FILING DATE: 04/02/01 GROUP ART UNIT: N/A 3616

JC498 U.S. PTO  
 10/382577  
 03/07/03

**U. S. PATENT DOCUMENTS**

EXAMINER INITIAL	DOCUMENT NUMBER	DATE	NAME	CLASS	SUBCLASS	FILING DATE
DD	5 3 4 3 9 7 0	9/94	Severinsky	180	65.2	
	5 4 9 2 1 9 2	2/96	Brooks et al			
	3 5 6 6 7 1 7	3/71	Berman et al			
	3 7 3 2 7 5 1	5/73	Berman et al			
	4 1 6 5 7 9 5	8/79	Lynch et al			
	5 1 1 7 9 3 1	6/92	Nishida			
	3 9 2 3 1 1 5	12/75	Helling			
	4 5 8 8 0 4 0	5/86	Albright, Jr., et al			
	5 3 1 8 1 4 2	6/94	Bates et al			
	5 1 2 0 2 8 2	6/92	Fjällström			
	4 4 0 5 0 2 9	9/83	Hunt			
	4 4 7 0 4 7 6	9/84	Hunt			
DD	4 3 0 5 2 5 4	12/81	Kawakatsu			

**FOREIGN PATENT DOCUMENTS**

	DOCUMENT NUMBER	DATE	COUNTRY	CLASS	SUBCLASS	TRANSLATION	
						YES	NO
DD	1 9 0 5 6 4 1	6/76	Germany			X	

**OTHER DOCUMENTS (Including Author, Title, Date, Pertinent Pages, Etc)**

DD	Simanaitis, "Electric Vehicles", Road & Track, May 1992, pp. 126-136
DD	Reynolds, "AC Propulsion CRX", Road & Track, Oct. 1992, pp. 126-129
DD	Kalberlah, "Electric Hybrid Drive Systems...", SAE Paper No. 910247, 1991
DD	Bullock, "The Technological Constraints of Mass, Volume, Dynamic Power Range and Energy Capacity..." SAE Paper No. 891659 1989
DD	Electric and Hybrid Vehicle Technology, vol. SP-915, SAE, Feb. 1992

EXAMINER: [Signature] DATE CONSIDERED: 11/19/04

EXAMINER: Initial if citation considered, whether or not citation is in conformance with MPEP/5609; Draw line through citation if not in conformance and not considered. Include copy of this form with next communication to the applicant.

<b>INFORMATION DISCLOSURE CITATION IN AN APPLICATION</b>	DOCKET NUMBER	PAICE201	APPLICATION NUMBER	09/822 866
	APPLICANT	Severinsky et al		
	FILING DATE	04/02/01	GROUP AMT UNIT	N/A

U.S. PATENT DOCUMENTS						
EXAMINER INITIAL	DOCUMENT NUMBER	DATE	NAME	CLASS	SUBCLASS	FILING DATE
DD	4 4 0 7 1 3 2	10/83	Kawakatsu			
	4 3 3 5 4 2 9	6/82	Kawakatsu			
	4 1 8 0 1 3 8	12/79	Shea			
	4 3 5 1 4 0 5	9/82	Fields et al			
	4 4 3 8 3 4 2	3/84	Kenyon			
	4 5 9 3 7 7 9	6/86	Krohling			
	4 9 2 3 0 2 5	5/90	Ellers			
	3 7 9 1 4 7 3	2/74	Rosen			
	4 2 6 9 2 8 0	5/81	ROSEN			
	4 4 0 0 9 9 7	8/83	Fiala			
	4 6 9 7 6 6 0	10/87	Wu et al			
	3 9 7 0 1 6 3	7/76	Kinoshita			
DD	4 0 9 5 6 6 4	6/78	Bray			

FOREIGN PATENT DOCUMENTS							
DOCUMENT NUMBER	DATE	COUNTRY	CLASS	SUBCLASS	TRANSLATION		
					YES	NO	

OTHER DOCUMENTS (Including Author, Title, Date, Pertinent Pages, Etc)	
DD	Wouk, "Hybrids: Then and Now", IEEE Spectrum, Vol. 32, 7, July 1995
DD	Bates, "Getting a Ford HEV on...", IEEE Spectrum, Vol. 32, 7, July 1995
DD	King et al, "Transit Bus takes...", IEEE Spectrum, Vol. 32, 7, July 1995
DD	Yamaguchi, "Toyota readies gasoline/electric hybrid system", Automotive Engineering, July 1997, pp. 55-58
DD	Wilson, "Not Electric, Not Gasoline..." Autoweek, June 2, 1997, pp. 17-18

EXAMINER	<i>[Signature]</i>	DATE CONSIDERED	11/19/04
----------	--------------------	-----------------	----------

EXAMINER: Initial if citation considered, whether or not citation is in conformance with MPEP §609; Draw line through citation if not in conformance and not considered. Include copy of this form with next communication to the applicant.

<b>INFORMATION DISCLOSURE CITATION IN AN APPLICATION</b>	DOCKET NUMBER	PAICE201	APPLICATION NUMBER	09/822,866 10/382577
	APPLICANT			
	Severinsky et al			
FILING DATE			GROUP ART UNIT	
04/02/01			N/A	

**U. S. PATENT DOCUMENTS**

EXAMINER INITIAL	DOCUMENT NUMBER	DATE	NAME	CLASS	SUBCLASS	FILING DATE
DD	4 1 4 8 1 9 2	4/79	Cummings			
	4 3 0 6 1 5 6	12/81	Monaco et al			
	4 3 1 3 0 8 0	11/82	Park			
	4 3 5 4 1 4 4	10/82	McCarthy			
	4 5 3 3 0 1 1	8/85	Heidemeyer			
	4 9 5 1 7 6 9	8/90	Kawamura			
	5 0 5 3 6 3 2	10/91	Suzuki et al			
	3 5 2 5 8 7 4	8/70	Toy			
	3 6 5 0 3 4 5	8/72	Yardney			
	3 8 3 7 4 1 9	9/74	Nakamura			
	3 8 7 4 4 7 2	4/75	Deane			
	4 0 4 2 0 5 6	8/77	Horwinski			
DD	4 5 6 2 8 9 4	1/86	Yang			

**FOREIGN PATENT DOCUMENTS**

DOCUMENT NUMBER	DATE	COUNTRY	CLASS	SUBCLASS	TRANSLATION	
					YES	NO

**OTHER DOCUMENTS** (Including Author, Title, Date, Pertinent Pages, Etc)

DD	Bulgin, "The Future Works, Quietly", Autoweek, Feb. 23, 1998 pp. 12-13
DD	"Toyota Electric and Hybrid Vehicles", a Toyota brochure
DD	Nagasaka et al, "Development of the Hybrid/Battery ECU...", SAE paper 981122, 1998, pp. 19-27

EXAMINER	<i>[Signature]</i>	DATE CONSIDERED	11/19/04
----------	--------------------	-----------------	----------

EXAMINER: Initial if citation considered, whether or not citation is in conformance with MPEP 5609; Draw line through citation if not in conformance and not considered. Include copy of this form with next communication to the applicant.



<b>INFORMATION DISCLOSURE CITATION IN AN APPLICATION</b>	DOCKET NUMBER	PAICE201	APPLICATION NUMBER	09/822-866
	APPLICANT			
	Severinsky et al			
FILING DATE			GROUP ART UNIT	
04/02/01			N/A	

**U. S. PATENT DOCUMENTS**

EXAMINER INITIAL	DOCUMENT NUMBER	DATE	NAME	CLASS	SUBCLASS	FILING DATE
DD	4 6 1 1 4 6 6	9/86	Keedy			
	4 8 1 5 3 3 4	3/89 <del>8/85</del>	Lexen			
	3 6 2 3 5 6 8	11/71	Mori			
	3 4 5 4 1 2 2	7/69 <del>8/65</del>	Grady, Jr.			
	3 2 1 1 2 4 9	10/65	Papst			
	2 6 6 6 4 9 2	1/54	Nims et al			
	3 5 0 2 1 6 5	3/70	Matsukata			
	1 8 2 4 0 1 4	9/31	Froelich			
	3 8 8 8 3 2 5	6/75 <del>10/75</del>	Reinbeck			
	4 5 7 8 9 5 5	4/86	Medina			
	4 7 6 5 6 5 6	8/88	Weaver			
	4 4 3 9 9 8 9	4/84	Yamakawa			
DD	5 3 0 1 7 6 4	4/94	Gardner			

**FOREIGN PATENT DOCUMENTS**

DOCUMENT NUMBER	DATE	COUNTRY	CLASS	SUBCLASS	TRANSLATION	
					YES	NO

**OTHER DOCUMENTS** (Including Author, Title, Date, Pertinent Pages, Etc)

EXAMINER	DATE CONSIDERED 11/19/04
----------	--------------------------

EXAMINER: Initial if citation considered, whether or not citation is in conformance with MPEP §609; Draw line through citation if not in conformance and not considered. Include copy of this form with next communication to the applicant.

<b>INFORMATION DISCLOSURE CITATION IN AN APPLICATION</b>	DOCKET NUMBER	PAICE201	APPLICATION NUMBER	09/822,866
	APPLICANT			
	Severinsky et al			
FILING DATE			GROUP ART UNIT	
04/02/01			N/A	

U.S. PATENT DOCUMENTS											
EXAMINER INITIAL	DOCUMENT NUMBER					DATE	NAME	CLASS	SUBCLASS	FILING DATE	
D	5	3	4	6	0	3	1	9/94	Gardner		
	5	6	6	7	0	2	9	9/97	Urban et al		
	5	7	0	4	4	4	0	1/98	Urban et al		
	5	4	9	5	9	0	6	3/96	Furutani		
	5	8	4	2	5	3	4	12/98	Frank	180	65.2
	5	8	2	3	2	8	0	10/98	Lateur	180	65.2
	5	8	2	6	6	7	1	10/98	Nakae et al		
	5	8	4	6	1	5	5	12/98	Taniguchi et al		
	5	8	4	5	7	3	1	12/98	Buglione et al	180	65.2
	5	5	8	6	6	1	3	12/96	Ehsani		
	5	6	3	5	8	0	5	6/97	Ibaraki et al		
	5	2	4	9	6	3	7	10/93	Heidl et al		
	D	5	5	5	8	5	8	8	9/96	Schmidt	

FOREIGN PATENT DOCUMENTS											
	DOCUMENT NUMBER					DATE	COUNTRY	CLASS	SUBCLASS	TRANSLATION	
										YES	NO

OTHER DOCUMENTS		(Including Author, Title, Date, Pertinent Pages, Etc.)	

EXAMINER	<i>[Signature]</i>	DATE CONSIDERED	11/19/04
EXAMINER: Initial if citation considered, whether or not citation is in conformance with MPEP §609; Draw line through citation if not in conformance and not considered. Include copy of this form with next communication to the applicant.			

**INFORMATION DISCLOSURE CITATION  
IN AN APPLICATION**

DOCKET NUMBER **PAICE201**

APPLICATION NUMBER **09/822,866**

APPLICANT **Severinsky et al**

FILING DATE **04/02/01**

GROUP ART UNIT **N/A**

**U.S. PATENT DOCUMENTS**

EXAMINER INITIAL	DOCUMENT NUMBER	DATE	NAME	CLASS	SUBCLASS	FILING DATE
<i>DD</i>	5 5 5 8 5 9 5	<i>9/96, 10/95</i>	Schmidt et al			
	5 9 <sup>08</sup> 8 8 0 7 7	6/99	Moore			
	5 7 2 2 9 1 1	3/98	Ibaraki et al			
	5 7 8 9 8 8 2	8/98	Ibaraki et al			
	5 5 5 0 4 4 5	8/96	Nii			
	5 6 5 0 9 3 1	7/97	Nii			
	5 8 6 5 2 6 3	2/99	Yamaguchi et al			
	5 7 8 8 0 0 6	8/98	Yamaguchi et al			
	5 7 9 1 4 2 7	8/98	Yamaguchi et al			
	5 7 9 9 7 4 4	9/98	Yamaguchi et al			
	5 8 0 6 6 1 7	9/98	Yamaguchi et al			
	5 8 9 9 2 8 6	5/99	Yamaguchi et al			
<i>DD</i>	5 4 3 3 2 8 2	7/95	Moroto et al			

**FOREIGN PATENT DOCUMENTS**

DOCUMENT NUMBER	DATE	COUNTRY	CLASS	SUBCLASS	TRANSLATION	
					YES	NO

**OTHER DOCUMENTS** (Including Author, Title, Date, Pertinent Pages, Etc)

EXAMINER *[Signature]* DATE CONSIDERED *11/19/04*  
 EXAMINER: Initial if citation considered, whether or not citation is in conformance with MPEP §609; Draw line through citation if not in conformance and not considered. Include copy of this form with next communication to the applicant.

<b>INFORMATION DISCLOSURE CITATION IN AN APPLICATION</b>	DOCKET NUMBER	PAICE201	APPLICATION NUMBER	09/822,866
	APPLICANT			
	Severinsky et al			
FILING DATE			GROUP ART UNIT	
04/02/01			N/A	

**U.S. PATENT DOCUMENTS**

EXAMINER INITIAL	DOCUMENT NUMBER	DATE	NAME	CLASS	SUBCLASS	FILING DATE	
						YES	NO
DD	5 7 7 8 3 2 6	7/98	Moroto et al				
	5 7 7 5 4 4 9	7/98	Moroto et al				
	5 6 9 7 4 6 6	12/97	Moroto et al	180	65.2		
	5 6 0 8 3 0 8	3/97	Kiuchi et al				
	5 6 1 4 8 0 9	3/97	Kiuchi et al				
	5 6 2 1 3 0 4	4/97	Kiuchi et al				
	5 8 9 3 8 9 5	4/99	Ibaraki				
	5 6 5 6 9 2 1	8/97	Farrall				
	5 7 7 3 9 0 4	6/98	Schiebold et al				
	5 5 1 5 9 3 7	5/96	Adler et al				
	5 6 5 0 7 1 3	7/97	Takeuchi et al				
	5 6 3 2 3 5 2	5/97	<del>Jeanneret</del> Jeanneret et al				
DD	5 4 9 2 1 8 9	2/96	Kreigler et al				

**FOREIGN PATENT DOCUMENTS**

DOCUMENT NUMBER	DATE	COUNTRY	CLASS	SUBCLASS	TRANSLATION	
					YES	NO

**OTHER DOCUMENTS** (Including Author, Title, Date, Pertinent Pages, Etc)

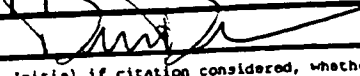
EXAMINER		DATE CONSIDERED	11/19/04
----------	---	-----------------	----------

EXAMINER: Initial if citation considered, whether or not citation is in conformance with MPSP §609; Draw line through citation if not in conformance and not considered. Include copy of this form with next communication to the applicant.

<b>INFORMATION DISCLOSURE CITATION IN AN APPLICATION</b>	DOCKET NUMBER	PAICE201	APPLICATION NUMBER	09/822,866
	APPLICANT			
	Severinsky et al			
FILING DATE			GROUP ART UNIT	
01/02/01			N/A	

U. S. PATENT DOCUMENTS						
EXAMINER INITIAL	DOCUMENT NUMBER	DATE	NAME	CLASS	SUBCLASS	FILING DATE
DD	4 3 5 4 1 4 4	10/82	McCarthy			
	4 6 9 7 6 6 0	10/87	Wu et al			
	5 8 3 1 3 4 1	11/98	Selfors et al			
	5 4 9 5 9 0 7	3/96	Data			
	5 6 7 2 9 2 0	9/97	Donegan et al			
	5 8 2 6 6 7 1	10/98	Nakae et al			
	5 7 5 7 1 5 1	5/98	Donegan et al			
	6 0 1 8 6 9 4	1/00	Egami et al	701	102	
	5 9 9 3 3 5 1	11/99	Deguchi et al	477	5	
	5 5 6 8 0 2 3	10/96	Grayer et al			
	5 8 9 0 5 5 5	4/99	Miller			
	5 1 7 2 7 8 4	12/92	Varela, Jr.			
DD	4 4 4 4 2 8 5	4/84	Stewart et al			

FOREIGN PATENT DOCUMENTS							
DOCUMENT NUMBER	DATE	COUNTRY	CLASS	SUBCLASS	TRANSLATION		
					YES	NO	

OTHER DOCUMENTS		(Including Author, Title, Date, Pertinent Pages, Etc)

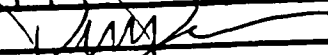
EXAMINER		DATE CONSIDERED	11/19/04
----------	---	-----------------	----------

EXAMINER: Initial if citation considered, whether or not citation is in conformance with MPEP §609; Draw line through citation if not in conformance and not considered. Include copy of this form with next communication to the applicant.

<b>INFORMATION DISCLOSURE CITATION IN AN APPLICATION</b>	DOCKET NUMBER	PAICE201	APPLICATION NUMBER	09/822,866
	APPLICANT			
	FILING DATE		GROUP ART UNIT	
		04/02/01	N/A	

U. S. PATENT DOCUMENTS					CLASS	SUBCLASS	FILING DATE
EXAMINER INITIAL	DOCUMENT NUMBER	DATE	NAME				
DD	4 5 6 2 8 9 4	1/86	Yang				
	4 4 9 5 4 5 1	1/85	Barnard				
	4 5 8 3 5 0 5	4/86	Frank et al				
	4 5 9 7 4 6 3	7/86	Barnard				
	5 7 8 9 8 8 1	8/98	Egami et al				
	5 7 8 6 6 4 0	7/98	Sakai et al				
	5 1 7 6 2 1 3	1/93	Kawai et al				
	5 8 3 9 5 3 0	11/98	Dietzel				
	5 8 9 8 2 8 2	4/99	Drozdz et al				
	5 3 2 7 9 8 7	7/94	Abdelmalek				
	5 4 1 5 2 4 5	5/95	Hammond				
	5 7 0 5 8 5 9	1/98	Karg et al				
DD	5 7 1 3 4 2 5	2/98	Buechhaus et al				

FOREIGN PATENT DOCUMENTS							
DOCUMENT NUMBER	DATE	COUNTRY	CLASS	SUBCLASS	TRANSLATION		
					YES	NO	

**OTHER DOCUMENTS** (Including Author, Title, Date, Pertinent Pages, Etc)

EXAMINER [Signature] DATE CONSIDERED 11/19/04

EXAMINER: Initial if citation considered, whether or not citation is in conformance with MP&P §609: Draw line through citation if not in conformance and not considered. Include copy of this form with next communication to the applicant.

<b>INFORMATION DISCLOSURE CITATION IN AN APPLICATION</b>	DOCKET NUMBER <b>PAICE201</b>	APPLICATION NUMBER <b>09/822,866</b>
	APPLICANT <b>Severinsky et al</b>	
	FILING DATE 04/02/01	GROUP ART UNIT <b>N/A</b>

**U.S. PATENT DOCUMENTS**

EXAMINER INITIAL	DOCUMENT NUMBER	DATE	NAME	CLASS	SUBCLASS	FILING DATE	
						YES	NO
DD	5 8 2 0 1 7 2	10/98	Brigham et al				
	5 7 1 3 4 2 6	2/98	Okamura				
	5 7 1 3 8 1 4	2/98	Hara et al				
	5 8 2 3 2 8 1	10/98	Yamaguchi et al				
	5 4 2 7 1 9 6	6/95	Yamaguchi et al				
	5 8 3 9 5 3 3	11/98	Mikami et al				
	5 7 2 5 0 6 4	3/98	Ibaraki et al				
	5 7 5 5 3 0 3	5/98	Yamamoto et al				
	5 7 7 8 9 9 7	7/98	Setaka et al				
	5 7 8 5 1 3 6	7/98	Falkenmayer et al				
	5 7 8 5 1 3 7	7/98	Reuyl				
	5 7 8 5 1 3 8	7/98	Yoshida				
DD	5 5 6 6 7 7 4	10/96	Yoshida				

**FOREIGN PATENT DOCUMENTS**

DOCUMENT NUMBER	DATE	COUNTRY	CLASS	SUBCLASS	TRANSLATION	
					YES	NO

**OTHER DOCUMENTS** (Including Author, Title, Date, Pertinent Pages, Etc)

EXAMINER 	DATE CONSIDERED <b>11/19/04</b>	EXAMINER: Initial if citation considered, whether or not citation is in conformance with MPEP §609; Draw line through citation if not in conformance and not considered. Include copy of this form with next communication to the applicant.
--	---------------------------------	--

<b>INFORMATION DISCLOSURE CITATION IN AN APPLICATION</b>	DOCKET NUMBER	PAICE201	APPLICATION NUMBER	09/822,866
	APPLICANT			
	Severinsky et al			
FILING DATE			GROUP ART UNIT	
04/02/01			N/A	

**U.S. PATENT DOCUMENTS**

EXAMINER INITIAL	DOCUMENT NUMBER	DATE	NAME	CLASS	SUBCLASS	FILING DATE	
						YES	NO
DD	5 4 9 2 1 9 0	2/96	Yoshida				
	5 4 4 1 1 2 2	8/95	Yoshida				
	5 5 5 8 1 7 5	9/96	Sherman				
	5 5 5 8 1 7 3	9/96	Sherman				
	5 7 8 8 5 9 7	8/98	Boll et al				
	5 7 8 8 0 0 3	8/98	Spiera				
	5 7 9 1 4 2 6	8/98	Yamada				
	5 3 2 3 8 6 8	6/94	Kawashima				
	5 5 4 5 9 2 8	8/96	Kotani				
	5 2 9 1 9 6 0	3/94	Brandenburg et al				
	5 2 5 5 7 3 3	10/93	King				
	5 6 6 4 6 3 5	9/97	Koga et al				
DD	5 4 6 3 2 9 4	10/95	Valdivia				

**FOREIGN PATENT DOCUMENTS**

DOCUMENT NUMBER	DATE	COUNTRY	CLASS	SUBCLASS	TRANSLATION	
					YES	NO

**OTHER DOCUMENTS** (Including Author, Title, Date, Pertinent Pages, Etc)

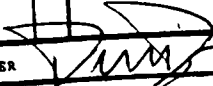
EXAMINER:  DATE CONSIDERED: 11/19/04

EXAMINER: Initial if citation considered, whether or not citation is in conformance with MPEP §609; Draw line through citation if not in conformance and not considered. Include copy of this form with next communication to the applicant.



<b>INFORMATION DISCLOSURE CITATION IN AN APPLICATION</b>	DOCKET NUMBER	PAICE201	APPLICATION NUMBER	09/822,866
	APPLICANT			
	Severinsky et al			
FILING DATE		04/02/01	GROUP ART UNIT	N/A

**U.S. PATENT DOCUMENTS**

EXAMINER INITIAL	DOCUMENT NUMBER	DATE	NAME	CLASS	SUBCLASS	FILING DATE
DD	5 5 6 2 5 6 5	10/96	Moroto et al			
	5 5 1 3 7 1 9	5/96	Moroto et al			
	5 5 1 3 7 1 8	5/96	Suzuki et al			
	5 8 3 3 0 2 2	11/98	Welke			
	5 8 4 1 2 0 1	11/98	Tabata et al			
	5 8 8 7 6 7 0	3/99	Tabata et al			
	5 8 6 2 4 9 7	1/99	Yano et al			
	5 6 3 7 9 8 7	6/95	Rattic et al			
	5 6 4 3 1 1 9	7/97	Yamaguchi et al			
	5 6 4 4 2 0 0	7/97	Yang			
	5 4 8 9 0 0 1	2/96	Yang			
	5 6 5 3 3 0 2	8/94	Edye et al			
DD	5 3 5 0 0 3 1	9/94	Sugiyama et al			

**FOREIGN PATENT DOCUMENTS**

DOCUMENT NUMBER	DATE	COUNTRY	CLASS	SUBCLASS	TRANSLATION	
					YES	NO

**OTHER DOCUMENTS** (Including Author, Title, Date, Pertinent Pages, Etc)

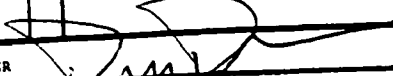
EXAMINER:  DATE CONSIDERED: 11/19/04

EXAMINER: Initial if citation considered, whether or not citation is in conformance with MPEP §609; Draw line through citation if not in conformance and not considered. Include copy of this form with next communication to the applicant.

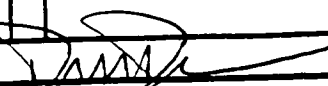
<b>INFORMATION DISCLOSURE CITATION IN AN APPLICATION</b>		DOCKET NUMBER	PAICE201	APPLICATION NUMBER	09/822,856		
		APPLICANT	Severinsky et al				
		FILING DATE	04/02/01	GROUP ART UNIT	N/A		
<b>U.S. PATENT DOCUMENTS</b>							
EXAMINER INITIAL	DOCUMENT NUMBER	DATE	NAME	CLASS	SUBCLASS	FILING DATE	
D	5 3 4 5 7 6 1	9/94	King et al				
	5 3 3 7 8 4 8	8/94	Bader				
	5 3 2 7 9 9 2	7/94	Holl				
	5 5 8 9 7 4 3	12/96	King				
	5 3 4 5 1 5 4	9/94	King				
	4 8 6 2 0 0 9	8/89	King				
	5 3 7 2 2 1 3	12/94	Hasebe et al				
	5 4 9 5 9 1 2	3/96	Gray, Jr., et al				
	5 5 8 8 4 9 8	12/96	Kitada				
	5 4 9 2 1 8 9	2/96	Kriegler				
	5 1 9 3 6 3 4	3/93	Masut				
	5 1 2 5 4 6 9	6/92	Scott				
	D	4 5 1 1 0 1 2	4/85	Rauneker			
<b>FOREIGN PATENT DOCUMENTS</b>							
	DOCUMENT NUMBER	DATE	COUNTRY	CLASS	SUBCLASS	TRANSLATION	
						YES	NO
<b>OTHER DOCUMENTS</b> (Including Author, Title, Date, Pertinent Pages, Etc)							
EXAMINER			DATE CONSIDERED	11/12/04			
EXAMINER: Initial if citation considered, whether or not citation is in conformance with MPSP §509: Draw line through citation if not in conformance and not considered. Include copy of this form with next communication to the applicant.							

<b>INFORMATION DISCLOSURE CITATION IN AN APPLICATION</b>	DOCKET NUMBER	PAICE201	APPLICATION NUMBER	09/822,866
	APPLICANT			
	Severinsky et al			
FILING DATE			GROUP ART UNIT	
04/02/01			N/A	

U. S. PATENT DOCUMENTS												
EXAMINER INITIAL	DOCUMENT NUMBER					DATE	NAME	CLASS	SUBCLASS	FILING DATE		
DD	4	6	3	1	4	5	6	12/86	Drescher et al			
	4	6	8	0	9	8	6	7/87	Elsner			
	4	9	5	3	6	4	6	9/90	Kim			
	5	9	2	7	4	1	7	7/99	Brunner et al	180	65.6	
	6	0	4	8	2	8	9	4/00	Hattori et al	477	15	
	6	0	2	6	9	2	1	2/00	Aoyama et al	180	65.2	
	6	0	5	3	8	4	2	4/00	Kitada et al	477	5	
	5	7	6	7	6	3	7	6/98	Lansberry	180	65.2	
	5	9	3	4	3	9	5	8/99	Koide et al	340	636	
	5	9	6	9	6	2	4	10/99	Sakai et al			
	5	9	8	6	3	7	6	11/99	Wexson			
	6	0	1	8	1	9	8	1/00	Tsuzuki et al	322	16	
DD	6	0	5	4	8	4	4	4/00	Frank			

FOREIGN PATENT DOCUMENTS									
DOCUMENT NUMBER	DATE	COUNTRY	CLASS	SUBCLASS	TRANSLATION				
					YES	NO			

**OTHER DOCUMENTS** (Including Author, Title, Date, Pertinent Pages, Etc)

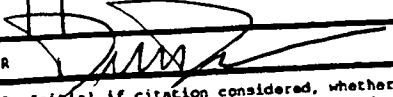
EXAMINER		DATE CONSIDERED	11/19/04
EXAMINER: Initial if citation considered, whether or not citation is in conformance with MPEP §609; Draw line through citation if not in conformance and not considered. Include copy of this form with next communication to the applicant.			

**INFORMATION DISCLOSURE CITATION  
IN AN APPLICATION**

DOCKET NUMBER **PAICE201** APPLICATION NUMBER **09/822,666**  
 APPLICANT **Severinsky et al**  
 FILING DATE **04/02/01** GROUP ART UNIT **N/A**

**U.S. PATENT DOCUMENTS**

EXAMINER INITIAL	DOCUMENT NUMBER	DATE	NAME	CLASS	SUBCLASS	FILING DATE
DD	6 0 5 9 0 5 9	5/00 9/98	Schmidt-Brucken			
	6 0 9 8 7 3 3	8/00	Ibaraki et al			
	6 1 6 1 3 8 4	12/00	Reinbold et al			
	5 9 9 6 3 4 7	12/99	Nagae et al			
	6 1 0 9 0 2 5	8/00	Murata et al			
	6 1 3 1 5 3 8	10/00	Kanai			
	4 7 7 4 8 1 1	10/88	Kawamura			
DD	5 3 2 7 9 9 2	7/94	Boll			
	5 2 4 9 8 3 7	10/93	Heldl et al			
	5 4 9 9 9 0 6	3/96	Furutani			
	6 0 1 8 8 9 4	1/00	Egami et al			
DD	6 2 0 9 6 7 2	4/01	Severinsky			

**DUPLICATION**  
//  
//

**FOREIGN PATENT DOCUMENTS**

DOCUMENT NUMBER	DATE	COUNTRY	CLASS	SUBCLASS	TRANSLATION	
					YES	NO

**OTHER DOCUMENTS** (Including Author, Title, Date, Pertinent Pages, Etc)

EXAMINER *[Signature]* DATE CONSIDERED **11/19/04**

EXAMINER: Initial if citation considered, whether or not citation is in conformance with RPSP 5609; Draw line through citation if not in conformance and not considered. Include copy of this form with next communication to the applicant.



IN THE UNITED STATES PATENT AND TRADEMARK OFFICE

In re the Patent Application of	:	
Severinsky et al	:	Examiner: N/A
Serial No.: 09/822,866	:	Group Art Unit: 3619
Filed: April 2, 2001	:	Att. Dkt.: PAICE201
For: Hybrid Vehicles	:	

Hon. Commissioner of Patents and Trademarks  
Washington, DC 20231

**SUPPLEMENTAL INFORMATION DISCLOSURE STATEMENT**

Dear Sir:

Listed on attached PTO-1449 forms are a number of new patents discovered after filing of the above application. Copies of the listed patents are enclosed. The Examiner is respectfully requested to consider these patents with respect to the claims of this application.

The relevance of the newly-listed patents may be summarized as follows:

US patent 6,307,276 to Bader shows a hybrid drive system comprising an engine, a traction motor coupled to the countershaft of a multispeed transmission, and a controller which determines a running average value for the vehicle's "required driving torque". The engine output power is then varied as the average required power changes. The specification and claims give examples of 15 and 50 seconds as the time period over which the average is calculated, and it is made clear that the engine power is varied accordingly slowly. Where the engine power is insufficient to satisfy the instantaneous torque requirement, the battery is used to supply power to a traction motor; conversely, when the engine is producing more power than is needed, the excess is used to charge the batteries.

Insofar as Fig. 2 of Bader suggests that the "required driving torque" can be negative (for example, a negative torque can be considered to be applied to the motor/generator(s) by the kinetic energy of the vehicle, i.e., under deceleration or

descents, for regenerative braking), this parameter might be misunderstood to be generally comparable to the "road load" parameter, which is analyzed by the present system to make its mode switching determinations, as illustrated by Figs. 6, 7, and 9. However, Bader's "drive power  $P_o$  can be calculated from the torque  $M_o$  and the rotational speed  $n_o$ ". Col. 4, lines 21-22. Hence the "drive power" is not in fact suggestive of applicants' road load, since the engine output, i.e., "the torque  $M_o$  at the gear input" (col. 4, line 18), cannot be negative.

In any event, there is no suggestion in Bader of changing operational modes of a hybrid vehicle responsive to the value of the "drive power  $P_o$ ", whether or not this is fairly equivalent to the road load. As made explicit by the relevant claims 1 - 9 of this application, according to an important aspect of the invention the vehicle is operated in different modes according to the road load (among other variables), and so that the engine is operated only under sufficient load to make its operation efficient. For example, when the road load is low, e.g., at low speeds, the engine is run only as necessary to charge the batteries. By comparison, in Bader it appears the engine is to be run constantly, and its speed varied slowly in accordance with the then average value of drive power. Bader thus fails to teach an important aspect of the invention.

Nii patent 6,131,680 is directed to a hybrid vehicle wherein an internal combustion engine and first and second motors are all connected to one of the sun gear, the planet carrier, or the ring gear of a planetary gearbox. Nii adjusts the relative gear ratios according to the torque required, which is apparently derived directly from the position of the accelerator pedal - see col. 22, lines 27 - 30. The Nii hybrid is operated in different modes depending on the state of charge of the battery, and the torque required. See Fig. 9. Under certain circumstances the planetary gearbox may be locked-up to avoid inefficiency. See, e.g., col. 9 line 1 - 7, and Fig. 10. However, the modes shown by Nii are not the same as those used by applicants, although there

are some similarities. For example, as stated at col. 37, lines 1 - 6, and in Fig. 26, Nii sets his engine speed to idle when the vehicle is being operated in "motor driving" (i.e., electric car) mode; this is highly inefficient, since the engine produces no useful power at idle. By comparison, applicants shut the engine off completely except when it is being operated at high efficiency.

Mikami patent 5,839,533 is discussed in the application as filed, but was apparently not listed on the PTO-1449 forms filed previously; this patent is accordingly listed on the PTO-1449 filed herewith. A copy of this patent is also provided herewith.

Stemler patent 6,300,735 relates to control of planetary gearboxes as might be used in hybrid vehicles to control the torque supplied by the internal combustion engine and electric motors. Such a gearbox is not a feature per se of the invention described by the claims of the present application.

Yanase et al patent 6,318,487 shows a scheme for braking a hybrid vehicle when the battery is fully charged, so that regenerative braking would be inappropriate, and whereby friction braking is avoided; specifically, the engine is motored, so that energy is consumed by compressing air in the engine. This is not a feature of the invention defined by the claims of this application.

Deguchi et al patent 6,278,915 shows a control system for a hybrid comprising a continuously-variable transmission, wherein the transmission ratio is set responsive to target values for the driving torque, the generated electrical power, and the engine speed. Such a transmission is not found in the system defined by the claims of this application, and the control scheme described by this patent is irrelevant to the present claims.

Deguchi et al patent 6,190,282 relates to controlling the engine, motor, and clutch of a hybrid so as to avoid shock to the passengers upon clutch engagement. This is not relevant to the claims of the present application. A similar Deguchi et al patent, 5,993,351, was made of record previously.

Obayashi et al patent 6,232,733 appears to be a further development of the invention described in Egami patents 5,789,881 and 6,018,694, previously made of record. All three of these patents relate to operating the electric motors of a hybrid to reduce vibration when the engine is started. This is not a feature of the claims of this application.

Friedmann et al patent 5,788,004 shows a control system for hybrid vehicles wherein the overall system efficiency is continuously optimized by adjustment of the operational parameters of the various system components.

Kashiwase patent 6,146,302 shows a drive system for a hybrid wherein an engine and first motor are connected to the ring gear of a planetary gearbox, a second motor is connected to its planet carrier, a transmission is connected between the planet carrier and the road wheels of the vehicle, and clutches are provided to engage two of the sun gear, planet carrier and ring gear. No such planetary gearbox is required by the system of the invention.

Frank patent 6,116,363 is stated to be a continuation-in-part of patent 5,842,534, already made of record and discussed in this application as filed. Both of these Frank patents disclose a braking system for a hybrid vehicle wherein the first 30% of pedal travel initiates regenerative braking, while the latter 70% of pedal travel initiates mechanical braking. See also Frank patent 6,054,844, already of record, which limits the braking torque to be provided by regenerative braking as a function of vehicle speed.

Maeda et al patent 6,074,321 shows a transaxle for a hybrid vehicle having a specific construction that is not particularly relevant to any of the claims of this application.

Moroto reissue patent Re. 36,678 is a reissue of patent 5,513,719, already of record.

Finally, Severinsky et al patent 6,338,391 has recently issued on application Serial No. 09/392,743, that is, is one of the parent applications.



An early and favorable action on the merits of the application is earnestly solicited.

2/8/02  
Dated

Respectfully submitted,

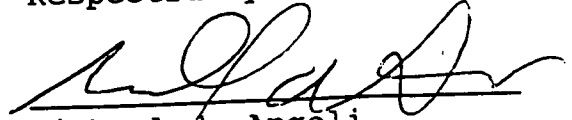

Michael de Angeli  
Reg. No. 27,869  
60 Intrepid Lane  
Jamestown, RI 02835  
401-423-3190







THE UNITED STATES PATENT AND TRADEMARK OFFICE

In re the Patent Application of :  
Severinsky et al : Examiner: David Dunn  
Serial No.: 09/822,866 : Group Art Unit: 3616  
Filed: April 2, 2001 : Att. Dkt.: PAICE201  
For: Hybrid Vehicles :

Hon. Commissioner of Patents and Trademarks  
Washington, DC 20231

SECOND SUPPLEMENTAL INFORMATION DISCLOSURE STATEMENT

Dear Sir:

Listed on accompanying PTO-1449 form(s) are a number of additional patents that may be considered relevant by the Examiner to the claims of this application. These patents were identified in supplemental searching conducted after the filing of the application. Copies of the newly-cited documents are provided herewith. The examiner is respectfully requested to consider these documents in connection with the patentability of the claims of this application. Citation of these documents should not be construed to admit they are necessarily statutory prior art effective against this application.

The relevance of the documents thus cited is as follows:

Goehring et al patent 6,394,209 discloses a hybrid vehicle in which the internal combustion engine is stated to be operated only at or near full load. To thus operate the engine of the vehicle of the invention is an object of the invention, and a limitation to that effect is present in claim 1 of the application as amended. However, the Goehring reference refers only to a serial hybrid, and therefore does not teach a hybrid vehicle operated in different modes responsive to the road load, as also required by claim 1.

Tabata et al patent 6,081,042, to be candid, is extremely difficult to comprehend. It does appear that Tabata shows a hybrid vehicle which can be driven by a motor/generator, an

engine, or both, the operation mode to be chosen based on "the currently required output Pd" and the battery state of charge. See Fig. 6 and cols. 17 - 20. Insofar as understood, the value Pd is not the same thing as applicants' instantaneous torque requirement or road load RL. Pd is defined as "an output of the hybrid drive system 210 required to drive the vehicle against a running resistance. This currently required output Pd is calculated according to a predetermined data map or equation, on the basis of the operation amount  $\theta_{AC}$  of the accelerator pedal, a rate of change of this value  $\theta_{AC}$ , running speed of the vehicle (speed  $N_0$  of the output shaft 19) or the currently established operating position of the automatic transmission." Col. 18, lines 34 - 42.

Another Tabata patent, 5,982,045, is directed to control of mode shifting in a hybrid such that transmission ratios or torque distribution ratio changes are prevented from occurring concurrently with mode shifting, the goal evidently being to smooth mode shifting. No disclosure of control of mode shifting responsive to a quantity comparable to applicants' road load is apparent.

Lawrie et al patent 5,993,350 discloses an "automated manual transmission clutch controller" which purports to combine the advantages of conventional automatic and manual transmissions. Mode shifting is evidently carried out responsive to any or several of various "information..includ[ing] vehicle speed, RPM or the like..[or] other vehicle condition signals". Col. 8, lines 37 - 49. The disclosures of three further Lawrie and Lawrie et al patents, 6,006,620, 6,019,698, and 5,797,257 appear to be essentially identical.

Nagano et al patent 6,059,064 shows a hybrid vehicle and appears to be directed to improvements in the braking system employed; these include using a prime mover (e.g., an electric motor) on one axle and another, e.g., an IC engine on another axle. Hill-holding is also addressed, as is anti-lock. The improvements in brake "feel" addressed in the present application do not appear to be discussed by Nagano.

The Examiner is respectfully urged to consider these patents in connection with examination of this application, and to indicate that he has done so in the file of the case.

Respectfully submitted,



Michael de Angeli  
Reg. No. 27,869  
60 Intrepid Lane  
Jamestown, RI 02835  
401-423-3190

9/1/02

Dated



J0498 U.S. PTO  
 10/382577  
 03/07/03

<b>INFORMATION DISCLOSURE CITATION IN AN APPLICATION</b>	DOCKET NUMBER <b>PAICE201</b>	APPLICATION NUMBER <b>09/822,866</b>
	FILING DATE <b>4/2/2001</b>	GROUP AND UNIT <b>3616</b>
<b>U.S. PATENT DOCUMENTS</b>		

EXAMINER INITIAL	DOCUMENT NUMBER	DATE	NAME	CLASS	SUBCLASS	FILING DATE
DD	639420	95/2002	Goehring et al			
	608104	26/2000	Tabata et al			
	598204	511/1999	Tabata et al			
	599335	011/1999	Lawrie et al			
	601969	802/2000	Lawrie et al			
	597925	711/1999	Lawrie			
	600662	012/1999	Lawrie et al			
DD	605906	405/2000	Nagano et al			

FOREIGN PATENT DOCUMENTS						
DOCUMENT NUMBER	DATE	COUNTRY	CLASS	SUBCLASS	TRANSLATION	
					YES	NO

OTHER DOCUMENTS (Including Author, Title, Date, Pertinent Pages, Etc)

EXAMINER	DATE CONSIDERED	11/19/04
----------	-----------------	----------

EXAMINER: Initial if citation considered, whether or not citation is in conformance with MPEP §609; Draw line through citation if not in conformance and not considered. Include copy of this form with next communication to the applicant.

**Notice of Reference Cited**

Application/Control No.

09/822,866

Applicant(s)/Patent Under Reexamination  
SEVERINSKY ET AL.

Examiner

David Dunn

Art Unit

3616

Page 1 of 6

JUL 07 2006  
IAPET  
TRADEMARK

JC198 U.S. PTO  
10/382577  
03/07/03

**U.S. PATENT DOCUMENTS**

*	Document Number Country Code-Number-Kind Code	Date MM-YYYY	Name	Classification
A	US-6,315,068	11-2001	Hoshiya et al.	180/65.2
B	US-6,330,498	12-2001	Tamagawa et al.	701/22
C	US-6,359,404	03-2002	Sugiyama et al.	318/432
D	US-6470983	10-2002	Amano et al.	180/65.2
E	US-			
F	US-			
G	US-			
H	US-			
I	US-			
J	US-			
K	US-			
L	US-			
M	US-			

**FOREIGN PATENT DOCUMENTS**

*	Document Number Country Code-Number-Kind Code	Date MM-YYYY	Country	Name	Classification
N					
O					
P					
Q					
R					
S					
T					

**NON-PATENT DOCUMENTS**

*	U	V	W	X

*[Handwritten signature]*

11/19/04

\*A copy of this reference is not being furnished with this Office action. (See MPEP § 707.05(a).)  
Dates in MM-YYYY format are publication dates. Classifications may be US or foreign.

U.S. Patent and Trademark Office  
PTO-892 (Rev. 01-2001)

Notice of References Cited

Part of Paper No. 14





IN THE UNITED STATES PATENT AND TRADEMARK OFFICE

In re the Patent Application of :  
 Severinsky et al : Examiner: David Dunn  
 Serial No.: 09/822,866 : Group Art Unit: 3616  
 Filed: April 2, 2001 : Att. Dkt.: PAICE201  
 For: Hybrid Vehicles :

Hon. Commissioner of Patents and Trademarks  
 Washington, DC 20231

THIRD SUPPLEMENTAL INFORMATION DISCLOSURE STATEMENT

Dear Sir:

Listed on accompanying PTO-1449 form(s) are five Japanese patent publications that may be considered relevant by the Examiner to the claims of this application. These publications were cited by the Japanese Patent Office in an office action dated September 2, 2002 in connection with prosecution of a Japanese patent application corresponding to the parent US applications, Ser. No. 09/264,817, now patent 6,209,672, and Ser. No. 09/392,743, now patent 6,338,391. A copy of a translation of this Japanese office action is attached, and copies of the newly-cited documents are provided herewith marked (1) - (5), in accordance with the Japanese Examiner's usage; copies of uncertified, partial translations of references 1 and 4 are also provided. The Examiner is respectfully requested to consider these documents in connection with the patentability of the claims of this application.

The relevance of the documents thus cited is as follows:

Japanese utility model registration 63-82283, published as "laid-open No. 2-7702", which was referred to in the Japanese office action as Reference 1 (a partial noncertified translation also being supplied), shows a hybrid vehicle comprising an internal combustion engine, an electric "traction" motor for providing additional torque to the wheels of the vehicle, and a

second electric motor that can be operated to also supply additional torque to the wheels or operate as a generator to charge the battery during braking or hill descent. Typically, such hybrids are operated in different modes depending on whether the vehicle is sitting at a traffic light, accelerating, cruising on the highway, and so on. The same is true of the vehicle of the present invention.

In order that the hybrid vehicle can be made commercially acceptable, it is important that the "mode switching" decisions be made by a microprocessor or the like instead of the driver. Various references teach making this decision in different ways. Reference 1 does not address this question. Commonly, as in Japanese published application 06-080048, cited by the Japanese patent office as Reference 3 (which corresponds to US patent 5,697,466, already of record), the decision is made based on the degree to which the driver has depressed the accelerator pedal. By comparison, according to the present invention, as discussed extensively in the earlier prosecution of this and the parent applications, the mode switching decision is made based on the vehicle's instantaneous torque requirement or "road load" RL.

As previously, it is important to emphasize exactly what the terms "road load" RL means as used in the present claims, to distinguish over the art. "Road load" is a somewhat subtle concept, since during many phases of vehicle operation the road load quantitatively resembles, for example, the operator's foot pressure on the accelerator pedal, or simply the engine output power. However, the road load as used herein is neither of these. "Road load" as used herein is simply that amount of torque that must be supplied to the vehicle wheels in order to carry out the operator's current command.

Note that "road load" as thus defined can be positive, as during highway cruising, "highly" positive, as during acceleration or hill-climbing, negative, as during hill descent, and "heavily" negative, as during braking. Figs. 7 and 13 show

this clearly, and it is explained in the specification of the application as well. The flowchart of Fig. 9 illustrates precisely how the mode switching decisions are made responsive to road load (with an additional variation possible based on the battery state of charge.)

The fact that according to the present invention the mode switching decisions are made responsive to road load, a quantity which can be positive or negative, distinguishes this invention from all prior art of which we are aware. It will be appreciated that making all of the mode switching decisions based essentially on monitoring this single variable (with subsidiary attention to the battery state of charge, as below) greatly simplifies the decision-making process, as compared, for example, to a system in which the operator's foot pressure on the throttle and brake pedals must be continually monitored.

The new references made of record hereby does not show this invention. Reference 1 does show a hybrid vehicle having components arranged comparably to those recited in claim 1, but there is no mention of the manner in which the mode-switching determinations are made. The Japanese Examiner made the comment that "the vehicle is operated in a plurality of operating modes in response to states of operation such as a load of the vehicle and the like", apparently based on the description in reference 1 of vehicle operation in different modes depending on the driving conditions. However, we find nothing in reference 1 that suggests mode switching based on road load as defined above.

None of the other references cited by the Japanese Examiner and made of record hereby (nor any of those previously made of record, of course) supply this deficiency of Reference 1. The Japanese Examiner cited published application 06-144020 (referred to as reference 2) against claim 1, for showing that the first motor also starts the engine, and cited reference 3 against claim 2, for showing that the state of charge of the battery can be considered in mode switching.

More specifically, in his remarks concerning claim 4, the Japanese Examiner asserted that reference 3 describes mode switching responsive to "road load (a press down amount of an accelerator pedal) (see [Fig. 3]) or the like". As above, "road load" as used in this application is something quite different than the degree to which the accelerator pedal is pressed down; for example, the latter cannot be negative, and road load as used herein can decidedly be negative. We have reviewed US patent 5,697,466 (which corresponds to Reference 3) in detail and it shows nothing comparable to mode switching based on road load as used in this application.

Claims 8 and 9 of this application are directed to the "turbocharger-on-demand" concept, which was an important aspect of the invention in parent application Ser. No. 09/392,743, now patent 6,338,391. Claims 15 - 20 of the Japanese application recite this concept, i.e., that of a turbocharger that is operated only when the road load exceeds a predetermined value for more than a minimum period of time. That is, the turbocharger is not operated continually, as in the usual prior art vehicles, but is only operated when needed, i.e., when road load exceeds the engine's normally aspirated torque capabilities (i.e.,  $RL > MTO$ ); moreover, the turbocharger is operated only when  $RL > MTO$  for more than some predetermined period of time  $T$ . This is an extremely powerful concept, and one which is only applicable to a hybrid vehicle. Providing the turbocharger on demand allows the engine to provide additional torque when needed, but to operate as a smaller, more efficient engine at other times.

More specifically, in a conventional turbocharged vehicle the turbocharger is spinning constantly, so that a turbine driven by the exhaust flow drives a compressor forcing air into the engine. The main problem with turbochargers as thus used is poor throttle response or "turbo lag", that is, a substantial time delay between the driver calling for more power by pressing on

the accelerator pedal and the engine's response. While some progress has been made, mostly by use of smaller turbochargers, this problem is inevitable to some degree, since it takes some time for the turbocharger to "spool up" to its full speed.

The Japanese Examiner cited Japanese published application 55-069724 as reference 4; as noted, a partial noncertified translation of this reference is also provided. Reference 4 shows a turbocharger which is operated on demand, in response to a "load detecting means"; this is the first reference we have seen showing this concept. There is no suggestion of use of this turbocharger in a hybrid vehicle. A conventional (i.e., non-hybrid) vehicle fitted with a turbocharger of this type would have extremely poor throttle response if used to provide additional power for passing (i.e., overtaking) or hillclimbing; the "turbo lag" inherent in operation of a turbocharger starting from zero rpm would be on the order of tens of seconds, which would be totally unacceptable for a consumer vehicle. Possibly such a system would be useful in heavy truck operation or the like, where the load will vary significantly depending on whether the truck was loaded or not; in that case, the operator could be the "load detecting means", i.e., could throw a switch when he knew high power would be needed for an extended period of time.

By comparison, a turbocharger can be employed "on demand" in a hybrid vehicle according to the invention without poor throttle response caused by turbo lag, and without requiring any intervention by the operator. This is simply because the traction motor can be used to supply the vehicle's torque requirements in excess of MTO. Thus, when  $RL > MTO$ , the traction motor provides the additional torque required. If  $RL > MTO$  for longer than T, the turbocharger is activated and begins to spin. When it is up to operating speed, the traction motor can be deactivated. All this is shown clearly by Fig. 13, and would not be possible simply given the turbocharger-on-demand of Reference 4 in a conventional, non-hybrid vehicle. By comparison, in the

present vehicle, at no point are the vehicle's torque requirements not met; therefore there is no "turbo lag".

It is apparent that this advantage can only be achieved by use of a turbocharger on demand in a hybrid vehicle. No combination of references can fairly be said to make this obvious. Specifically, the Japanese Examiner's comment as to claim 17, "it is a usual matter to control a turbocharger in response to a road load or the like" is not correct, for several reasons: no reference shows taking any kind of control action in response to road load as claimed; no reference suggests combining the turbocharger on demand of Reference 4 with a hybrid vehicle; and certainly no reference suggests the complete elimination of the turbo lag problem thus achieved, while at the same time the vehicle's useful load range is greatly broadened.

Finally, Japanese published application 04-274926 (Reference 5) was cited for a showing of preheating a catalyst before starting the associated engine, which is not a feature of the present claims.

The Examiner is respectfully urged to consider these patents in connection with examination of this application, and to indicate that he has done so in the file of the case.

Respectfully submitted,

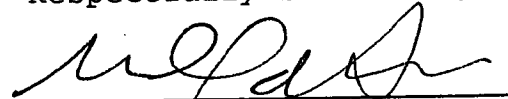

Michael de Angeli  
Reg. No. 27,869  
60 Intrepid Lane  
Jamestown, RI 02835  
401-423-3190

Nov. 28, 2002  
Dated



**This Page is Inserted by IFW Indexing and Scanning  
Operations and is not part of the Official Record**

**BEST AVAILABLE IMAGES**

Defective images within this document are accurate representations of the original documents submitted by the applicant.

Defects in the images include but are not limited to the items checked:

- BLACK BORDERS
- IMAGE CUT OFF AT TOP, BOTTOM OR SIDES
- FADED TEXT OR DRAWING
- BLURRED OR ILLEGIBLE TEXT OR DRAWING
- SKEWED/SLANTED IMAGES
- COLOR OR BLACK AND WHITE PHOTOGRAPHS
- GRAY SCALE DOCUMENTS
- LINES OR MARKS ON ORIGINAL DOCUMENT
- REFERENCE(S) OR EXHIBIT(S) SUBMITTED ARE POOR QUALITY
- OTHER: \_\_\_\_\_

**IMAGES ARE BEST AVAILABLE COPY.**

**As rescanning these documents will not correct the image problems checked, please do not report these problems to the IFW Image Problem Mailbox.**



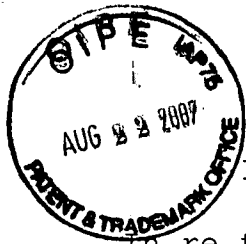

LFu

IN THE UNITED STATES PATENT AND TRADEMARK OFFICE

In re the Patent Application of :

Severinsky et al	:	Examiner: N/A
	:	
Serial No.: 11/429,457	:	Group Art Unit: 3616
	:	
Filed: May 8, 2006	:	Att.Dkt:PAICE201.DIV.3
	:	
For: Hybrid Vehicles	:	

Hon. Commissioner for Patents  
P.O. Box 1450  
Alexandria VA 22313-1450

INFORMATION DISCLOSURE STATEMENT

Sir:

Listed on an attached PTO-1449 are several Japanese references that have recently come to applicants' attention in connection with related foreign applications, and US patent 6,383,114, cited against copending Ser. No. 11/426,466. Citation of these documents herein is not to be construed as a concession that they are in fact available as prior art under 35 USC Sect. 102. Copies of the documents thus cited are attached. The Examiner is respectfully requested to consider the documents thus made of record, and to initial the PTO-1449 form, indicating that he or she has done so.

Should there be any questions the Examiner is invited to contact the undersigned at the number given below.

Early and favorable consideration of the application  
is earnestly solicited.

8/20/07  
Dated:

Respectfully submitted,

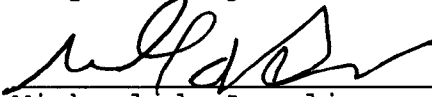

Michael de Angeli  
Reg. No. 27,869  
60 Intrepid Lane  
Jamestown RI 02835  
401-423-3190





UNITED STATES PATENT AND TRADEMARK OFFICE

UNITED STATES DEPARTMENT OF COMMERCE  
 United States Patent and Trademark Office  
 Address: COMMISSIONER FOR PATENTS  
 P.O. Box 1450  
 Alexandria, Virginia 22313-1450  
 www.uspto.gov

BIB DATA SHEET

CONFIRMATION NO. 1951

<b>SERIAL NUMBER</b> 11/429,457	<b>FILING or 371(c) DATE</b> 05/08/2006 <b>RULE</b>	<b>CLASS</b> 180	<b>GROUP ART UNIT</b> 3618	<b>ATTORNEY DOCKET NO.</b> PAICE201.DIV.3
------------------------------------	---	---------------------	-------------------------------	--

**APPLICANTS**

Alex J. Severinsky, Washington, DC;  
 Theodore Louckes, Holly, MI;

**\*\* CONTINUING DATA \*\*\*\*\***

This application is a DIV of 10/382,577 03/07/2003 PAT 7,104,347  
 which is a DIV of 09/822,866 04/02/2001 PAT 6,554,088  
 which is a CIP of 09/264,817 03/09/1999 PAT 6,209,672  
 which claims benefit of 60/100,095 09/14/1998  
 and said 10/382,577 03/07/2003  
 is a CIP of 09/392,743 09/09/1999 PAT 6,338,391  
 which claims benefit of 60/122,296 03/01/1999

**\*\* FOREIGN APPLICATIONS \*\*\*\*\***

**\*\* IF REQUIRED, FOREIGN FILING LICENSE GRANTED \*\***  
 06/02/2006

Foreign Priority claimed <input type="checkbox"/> Yes <input checked="" type="checkbox"/> No	<input type="checkbox"/> Met after Allowance	<b>STATE OR COUNTRY</b>	<b>SHEETS DRAWINGS</b>	<b>TOTAL CLAIMS</b>	<b>INDEPENDENT CLAIMS</b>
35 USC 119(a-d) conditions met <input type="checkbox"/> Yes <input checked="" type="checkbox"/> No	<input type="checkbox"/> /cfc/	DC	17	62	3
Verified and /CYNTHIA FRANCISCA COLLADO/	Examiner's Signature	Initials			
Acknowledged					

**ADDRESS**

Michael de Angeli  
 60 Intrepid Lane  
 Jamestown, RI 02835  
 UNITED STATES

**TITLE**

Hybrid vehicles

<b>FILING FEE RECEIVED</b> 3480	FEES: Authority has been given in Paper No. _____ to charge/credit DEPOSIT ACCOUNT No. _____ for following:	<input type="checkbox"/> All Fees
		<input type="checkbox"/> 1.16 Fees (Filing)
		<input type="checkbox"/> 1.17 Fees (Processing Ext. of time)
		<input type="checkbox"/> 1.18 Fees (Issue)
		<input type="checkbox"/> Other _____
		<input type="checkbox"/> Credit

PART B - FEE(S) TRANSMITTAL

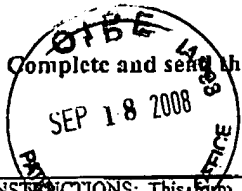

Complete and send this form, together with applicable fee(s), to: Mail Stop ISSUE FEE Commissioner for Patents P.O. Box 1450 Alexandria, Virginia 22313-1450 or Fax (571)-273-2885

INSTRUCTIONS: This form should be used for transmitting the ISSUE FEE and PUBLICATION FEE (if required). Blocks 1 through 5 should be completed where appropriate. All further correspondence including the Patent, advance orders and notification of maintenance fees will be mailed to the current correspondence address as indicated below or directed otherwise in Block 1, by (a) specifying a new correspondence address; and/or (b) indicating a separate "FEE ADDRESS" for maintenance fee notifications.

CURRENT CORRESPONDENCE ADDRESS (Note: Use Block 1 for any change of address)

Note: A certificate of mailing can only be used for domestic mailings of the Fee(s) Transmittal. This certificate cannot be used for any other accompanying papers. Each additional paper, such as an assignment or formal drawing, must have its own certificate of mailing or transmission.

7590 09/05/2008

Michael de Angeli 60 Intrepid Lane Jamestown, RI 02835

09/18/2008 RNEBRAH1 00000124 11429457

01 FC:1501 1440.00 OP
02 FC:1504 300.00 OP
03 FC:8001 30.00 OP

Certificate of Mailing or Transmission I hereby certify that this Fee(s) Transmittal is being deposited with the United States Postal Service with sufficient postage for first class mail in an envelope addressed to the Mail Stop ISSUE FEE address above, or being facsimile transmitted to the USPTO (571) 273-2885, on the date indicated below.

Michael de Angeli (Depositor's name)
[Signature] (Signature)
September 18, 2008 (Date)

Table with 5 columns: APPLICATION NO., FILING DATE, FIRST NAMED INVENTOR, ATTORNEY DOCKET NO., CONFIRMATION NO. Values: 11/429.457, 05/08/2006, Alex J. Severinsky, PAICE201.DIV.3, 1951

TITLE OF INVENTION: HYBRID VEHICLES

Table with 7 columns: APPLN. TYPE, SMALL ENTITY, ISSUE FEE DUE, PUBLICATION FEE DUE, PREV. PAID ISSUE FEE, TOTAL FEE(S) DUE, DATE DUE. Values: nonprovisional, NO, \$1440, \$300, \$0, \$1740, 12/03/2008

Table with 3 columns: EXAMINER, ART UNIT, CLASS-SUBCLASS. Values: COLLADO, CYNTHIA FRANCISCA, 3618, 180-065200

1. Change of correspondence address or indication of "Fee Address" (37 CFR 1.363).
2. For printing on the patent front page, list (1) the names of up to 3 registered patent attorneys or agents OR, alternatively, 1 Michael de Angeli (2) the name of a single firm (having as a member a registered attorney or agent) and the names of up to 2 registered patent attorneys or agents. If no name is listed, no name will be printed.

3. ASSIGNEE NAME AND RESIDENCE DATA TO BE PRINTED ON THE PATENT (print or type) PLEASE NOTE: Unless an assignee is identified below, no assignee data will appear on the patent. (A) NAME OF ASSIGNEE: PAICE LLC (B) RESIDENCE: (CITY and STATE OR COUNTRY) Bonita Springs, Florida

Please check the appropriate assignee category or categories (will not be printed on the patent): Individual [ ] Corporation [X] Government [ ]

4a. The following fee(s) are submitted: [X] Issue Fee [X] Publication Fee [X] Advance Order - # of Copies 10
4b. Payment of Fee(s): (Please first reapply any previously paid issue fee shown above) [ ] A check is enclosed. [X] Payment by credit card, Form PTO-2038 is attached. [ ] The Director is hereby authorized to charge the required fee(s), any deficiency, or credit any overpayment, to Deposit Account Number

5. Change in Entity Status (from status indicated above) [ ] a. Applicant claims SMALL ENTITY status. See 37 CFR 1.27. [ ] b. Applicant is no longer claiming SMALL ENTITY status. See 37 CFR 1.27(g)(2).

NOTE: The Issue Fee and Publication Fee (if required) will not be accepted from anyone other than the applicant; a registered attorney or agent; or the assignee or other party in interest as shown by the records of the United States Patent and Trademark Office.

Authorized Signature [Signature] Date 9/18/08
Typed or printed name Michael de Angeli Registration No. 27,869

This collection of information is required by 37 CFR 1.311. This information is required to obtain or retain a benefit by the public which is to file (and by the USPTO to process) an application. Confidentiality is governed by 35 U.S.C. 122 and 37 CFR 1.14. This collection is estimated to take 12 minutes to complete, including gathering, preparing, and submitting the completed application form to the USPTO. Time will vary depending upon the individual case. Any comments on the amount of time you require to complete this form and/or suggestions for reducing this burden, should be sent to the Chief Information Officer, U.S. Patent and Trademark Office, U.S. Department of Commerce, P.O. Box 1450, Alexandria, Virginia 22313-1450. DO NOT SEND FEES OR COMPLETED FORMS TO THIS ADDRESS. SEND TO: Commissioner for Patents, P.O. Box 1450, Alexandria, Virginia 22313-1450.

Under the Paperwork Reduction Act of 1995, no persons are required to respond to a collection of information unless it displays a valid OMB control number.

11/429457

<b>INFORMATION DISCLOSURE CITATION IN AN APPLICATION</b>	DOCKET NUMBER	PAICE201	APPLICATION NUMBER	09/8227866 10/382577
	APPLICANT	Severinsky et al		
	FILING DATE	04/02/01	GROUP ART UNIT	N/A

**U. S. PATENT DOCUMENTS**

EXAMINER INITIAL	DOCUMENT NUMBER	DATE	NAME	CLASS	SUBCLASS	FILING DATE
DD	4 1 4 8 1 9 2	4/79	Cummins			
	4 3 0 6 1 5 6	12/81	Monaco et al			
	4 3 1 3 0 8 0	11/82	Park			
	4 3 5 4 1 4 4	10/82	McCarthy			
	4 5 3 3 0 1 1	8/85	Heidemeyer			
	4 9 5 1 7 6 9	8/90	Kawamura			
	5 0 5 3 6 3 2	10/91	Suzuki et al			
	3 5 2 5 8 7 4	8/70	Toy			
	3 6 5 0 3 4 5	3-21-72	Yardney			
	3 8 3 7 4 1 9	9/74	Nakamura			
	3 8 7 4 4 7 2	4/75	Deane			
	4 0 4 2 0 5 6	8/77	Horwinski			
DD	4 5 6 2 8 9 4	1/86	Yang			

AE  
9-29-08

**FOREIGN PATENT DOCUMENTS**

DOCUMENT NUMBER	DATE	COUNTRY	CLASS	SUBCLASS	TRANSLATION	
					YES	NO

**OTHER DOCUMENTS** (Including Author, Title, Date, Pertinent Pages, Etc)

DD	Bulgin, "The Future Works, Quietly", Autoweek, Feb. 23, 1998 pp. 12-13
DD	"Toyota Electric and Hybrid Vehicles", a Toyota brochure
DD	Nagasaka et al, "Development of the Hybrid/Battery ECU...", SAE paper 981122, 1998, pp. 19-27

EXAMINER DD DATE CONSIDERED 11/19/04

EXAMINER: Initial if citation considered, whether or not citation is in conformance with MPEP §609; Draw line through citation if not in conformance and not considered. Include copy of this form with next communication to the applicant.



INFORMATION DISCLOSURE CITATION IN AN APPLICATION	DOCKET NUMBER	PAICE201.DIV	APPLICATION NUMBER	11/429,457	
	APPLICANT				
	Severinsky et al		FILING DATE	May 8, 2006	GROUP ART UNIT

**U.S. PATENT DOCUMENTS**

EXAMINER INITIAL	DOCUMENT NUMBER	DATE	NAME	CLASS	SUBCLAS	FILING DATE	
						YES	NO
	6 3 8 3 1 1 4	5/2002	Hoshiya et al				

**FOREIGN PATENT DOCUMENTS**

DOCUMENT NUMBER	DATE	COUNTRY	CLASS	SUBCLASS	TRANSLATION	
					YES	NO
02 1 0 1 9 0 3	<del>1990</del> 4-13-1990	Japan			part.	
55 1 2 7 2 2 1	<del>1980</del> 10-01-1980	Japan			x	
06 1 4 4 0 2 0	<del>1994</del> 5-24-1994	Japan			x	
04 3 4 1 6 5 7	<del>1992</del> 11-27-1992	Japan			sketch	

**OTHER DOCUMENTS** (Including Author, Title, Date, Pertinent Pages, Etc)

EXAMINER	/Cynthia Collado/ (08/26/2008)	DATE CONSIDERED	08/26/2008
----------	--------------------------------	-----------------	------------

EXAMINER: Initial if citation considered, whether or not citation is in conformance with MPEP §609; Draw line through citation if not in conformance and not considered. Include copy of this form with next communication to the applicant.

AE  
9-29  
08









11/429457

<b>INFORMATION DISCLOSURE CITATION IN AN APPLICATION</b>	DOCKET NUMBER	PAICE201.DIV	APPLICATION NUMBER	10/382,577
	APPLICANT	Severinsky et al		
	FILING DATE	3/7/2003	GROUP ART UNIT	3616

**U.S. PATENT DOCUMENTS**

EXAMINER INITIAL	DOCUMENT NUMBER	DATE	TITLE	CLASS	SUBCLASS	FILING DATE
DD	5 8 4 7 4 6 9	12/1998	Tabata			
DD	6 3 1 7 6 6 5	11/2001	Tabata			
DD	6 1 8 3 3 8 9	2/2001	Tabata			
DD	5 8 7 3 4 2 6	2/1999	Tabata			
DD	5 9 2 3 0 9 3	7/1999	Tabata			
DD	6 3 4 0 3 3 9	1/2002	Tabata			
DD	5 9 3 5 0 4 0	8/1999	Tabata et al.			
DD	5 4 1 5 6 0 3	5/1995	Tuzuki et al			
DD	6 2 5 8 0 0 1	7-10-2001 5/2001	Wakuta <b>A.P.T.A.L.</b>			
DD	5 8 9 0 4 7 0	4/1999	Woon			
DD	6 3 2 8 1 2 2	12/2001	Yamada			
DD	6 2 7 8 1 9 5	8/2001	Yamaguchi et al			

**RECEIVED**  
JUN 02 2004  
**GROUP 3600**

**FOREIGN PATENT DOCUMENTS**

	DOCUMENT NUMBER	DATE	COUNTRY	CLASS	SUBCLASS	TRANSLATION	
						YES	NO
DD	4 8 6 4 6 2 6	9/1973	Japan				part
DD	4 9 2 9 6 4 2	8/1974	Japan				"

**OTHER DOCUMENTS** (Including Author, Title, Date, Pertinent Pages, Etc)

DD	Published patent application US 2003/0085577 of Takaoka et al, May 8, 2003

EXAMINER: *[Signature]* DATE CONSIDERED: 11/29/04

EXAMINER: Initial if citation considered, whether or not citation is in conformance with MPEP § 609; Draw line through citation if not in conformance and not considered. Include copy of this form with next communication to the applicant.

AE  
9-29  
08



11/429457

INFORMATION DISCLOSURE CITATION IN AN APPLICATION		DOCKET NUMBER	PAICE201.DIV	APPLICATION NUMBER	10/382,577		
		APPLICANT	Severinsky et al				
		FILING DATE	3/7/2003	GROUP ART UNIT	3616		
U.S. PATENT DOCUMENTS							
EXAMINER INITIAL	DOCUMENT NUMBER	DATE	NAME	CLASS	SUBCLASS	FILING DATE	
DD	6 0 6 4 1 6 1	5/2000	Takahara				
DD	5 5 6 2 5 6 6	10/1996	Yang				
DD	5 2 1 2 4 3 1	5/1993	Origuchi et al				
	4 1 6 5 7 9 5	8/1979	Lynch et al			Previously cited	
DD	5 2 8 3 4 7 0	2/1994	Hadley et al				
DD	5 4 0 6 1 2 6	8/1995	Hadley et al				
DD	5 6 6 9 8 4 2	9/1997	Schmidt				
DD	5 7 7 1 4 7 8	6/1998	Tsukamoto				
DD	5 8 3 3 5 7 0	11/1998	Tabata				
DD	5 9 5 1 6 1 4	9/1999	Tabata				
DD	5 8 7 5 6 9 1	3/1999	Hata				
DD	5 9 3 1 2 7 1	8/1999	Haka				
FOREIGN PATENT DOCUMENTS							
	DOCUMENT NUMBER	DATE	COUNTRY	CLASS	SUBCLASS	TRANSLATION	
						YES	NO
DD	5 1 0 5 8 2	10/1992	European Patent Office				
DD	1 3 6 0 5 5	3/1985	European Patent Office				
DD	2 5 1 7 1 1 0	10/1975	German				
DD	8 2 0 1 1 7 0	4/1982	PCT/SE81/00280				
DD	5 5 1 1 0 3 2 8	8/1980	Japan				part
OTHER DOCUMENTS (Including Author, Title, Date, Pertinent Pages, Etc)							
DD	"Diesel-Electric VW", <i>Popular Science</i> , December 1990, p. 30.						
DD	"Electric Vehicles Only", <i>Popular Science</i> , May 1991, pp. 76-81 and 110.						
DD	"Lightweight, High-Energy Lead/Acid Battery" <i>NASA Tech Briefs</i> , 4/91, 22-24.						
EXAMINER	[Signature]		DATE CONSIDERED	11/29/04			
EXAMINER: Initial if citation considered, whether or not citation is in conformance with MPEP § 609; Draw line through citation if not in conformance and not considered. Include copy of this form with next communication to the applicant.							

AE  
9-29-  
08

RECEIVED  
JUN 02 2004  
GROUP 3600



11/429457

INFORMATION DISCLOSURE CITATION IN AN APPLICATION  1/2	DOCKET NUMBER	PAICE201.DIV	APPLICATION NUMBER	10/382,577
	APPLICANT	Severinsky et al		
	FILING DATE	3/7/2003	GROUP ART UNIT	3616

U.S. PATENT DOCUMENTS										
EXAMINER INITIAL	DOCUMENT NUMBER					DATE	NAME	CLASS	SUBCLAS	FILING DATE
DD	6	0	6	7	8	015	5/2000	Harada et al		
DD	4	4	1	1	1	711	10/1983	Fiala		
DD	3	6	2	0	3	235	5/1968	Maeda <i>ET AL.</i>		
DD	6	3	1	7	6	651	11/2001	Tabata et al		
DD	6	1	8	3	3	892	2/2001	Tabata et al		
DD	5	5	6	5	7	111	10/1996	Hagiwara		

AE  
9-29-  
08

FOREIGN PATENT DOCUMENTS												
	DOCUMENT NUMBER					DATE	COUNTRY	CLASS	SUBCLASS	TRANSLATION		
										YES	NO	
DD	7	5	4	9	8	3	2/1995	Japan			X	
DD	4	2	4	4	6	58	9/1992	Japan			X	
DD	11	0	8	2	2	613	3/1999	Japan				X
DD	11	1	2	2	7	124	4/1999	Japan			partial	
DD	62	1	1	3	9	565	5/1987	Japan			partial	

OTHER DOCUMENTS (Including Author, Title, Date, Pertinent Pages, Etc)									

EXAMINER <i>[Signature]</i>	DATE CONSIDERED	3/16/05
-----------------------------	-----------------	---------

EXAMINER: Initial if citation considered, whether or not citation is in conformance with MPEP 6609: Draw line through citation if not in conformance and not considered. Include copy of this form with next communication to the applicant.



UNITED STATES PATENT AND TRADEMARK OFFICE

UNITED STATES DEPARTMENT OF COMMERCE  
United States Patent and Trademark Office  
Address: COMMISSIONER FOR PATENTS  
P.O. Box 1450  
Alexandria, Virginia 22313-1450  
www.uspto.gov

APPLICATION NO.	FILING DATE	FIRST NAMED INVENTOR	ATTORNEY DOCKET NO.	CONFIRMATION NO.
11/429,457	05/08/2006	Alex J. Severinsky	PAICE201.DIV.3	1951
7590 Michael de Angeli 60 Intrepid Lane Jamestown, RI 02835		10/06/2008	EXAMINER COLLADO, CYNTHIA FRANCISCA	
			ART UNIT 3618	PAPER NUMBER
			MAIL DATE 10/06/2008	DELIVERY MODE PAPER

**Please find below and/or attached an Office communication concerning this application or proceeding.**  
The time period for reply, if any, is set in the attached communication.



UNITED STATES PATENT AND TRADEMARK OFFICE

Commissioner for Patents  
United States Patent and Trademark Office  
P.O. Box 1450  
Alexandria, VA 22313-1450  
www.uspto.gov

Serial No. : 11/429,457  
Applicant : SEVERIN-  
SKY  
Filing Date : 05/08/2006  
Date of Notice : 10/06/2008

## NOTICE TO FILE CORRECTED APPLICATION PAPERS

### *Notice of Allowance Mailed*

This application has been accorded an Allowance Date and is being prepared for issuance. The application, however, is incomplete for the reasons below.

Applicant is given 2 months from the date of this Notice within which to correct the informalities indicated below. If the informality pertains to the abstract, specification (including claims) or drawings, the informality must be corrected with an amendment in compliance with 37 CFR 1.121 (or, if the application is a reissue application, 37 CFR 1.173). Such an amendment may be filed after payment of the issue fee if limited to correction of informalities noted herein. See Waiver of 37 CFR 1.312 for Documents Required by the Office of Patent Publication, 1280 Off. Gaz. Patent Office 918 (March 23, 2004). In addition, if the informality is not corrected until after payment of the issue fee, for purposes of 35 U.S.C. 154(b)(1)(iv), "all outstanding requirements" will be considered to have been satisfied when the informality has been corrected. A failure to reply will result in the application being ABANDONED. **This period for reply is NOT extendable under 37 CFR 1.136(a).**

See attachment.

*A copy of this notice **MUST** be returned with the reply. Please address response to  
"Mail Stop Issue Fee, Commissioner for Patents,  
P.O. Box 1450, Alexandria, VA 22313-1450".*

*Registered users of EFS-Web may alternatively submit their reply to this notice via EFS-Web.*

/Diane Terry/  
Diane Terry  
Office of Data Management  
Phone: 703-308-9250, ext. 150

Application No. 11429457 Drawings filed 5-8-2006

**IDENTIFICATION OF DRAWING DEFICIENCIES**

- The character of the lines, numbers, and letters is poor. FIG(s) 14
- There is a hole or the image thereof within the illustration. FIG(s) \_\_\_\_\_
- An ink stamp or the image thereof obscures part of the illustration. FIG(s) \_\_\_\_\_
- The illustration is penetrated or traversed by a solid or broken line that is not intended to be part of the drawing, such as a dark line caused by a flaw in the copying process. FIG(s) \_\_\_\_\_
- The drawing is marred by black smudges, obliterations, or fax/copier marks (for example, speckles or dots in a substantial portion of the drawing). FIG(s) \_\_\_\_\_
- Figure numbers are duplicated or missing. FIG(s) \_\_\_\_\_
- Drawing sheet or figure is missing. FIG(s) \_\_\_\_\_
- Numbers, letters, or reference characters in the drawing have been crossed out or are illegibly handwritten. FIG(s) 3
- The drawing's background shows that the original drawing was made on graph paper or other paper with a pattern or decoration. FIG(s) \_\_\_\_\_
- The FIG. number label is placed in a location that causes the drawing to be read upside down. FIG(s) \_\_\_\_\_
- Data, a reference number, or part of the drawing is truncated or missing, or a lead line has no reference number. FIG(s) \_\_\_\_\_
- The drawing is continued onto a second page (or more) without proper labeling under 37 CFR 1.84(u)(1). FIG(s) \_\_\_\_\_
- The drawing and/or the FIG. label contain(s) foreign language. FIG(s) \_\_\_\_\_
- Color drawings are present in this application but the following 37 CFR 1.84(a) requirements have not been met\*:
  - Petition explaining why color drawings are necessary
  - Petition fee set forth in § 1.17(h)
  - Three (3) sets of color drawings
  - Color drawing paragraph in specification

\*If color drawings are not elected, then applicant **must respond** so stating. Also, references to color drawings in the specification, if any, must be amended.

COMMENTS: ID number located under 140.122 is unreadable  
(62 0764)



1FW

IN THE UNITED STATES PATENT AND TRADEMARK OFFICE

In re the Patent Application of :  
 Severinsky et al : Examiner: C. F. Collado  
 Serial No.: 11/429,457 : Group Art Unit: 3618  
 Filed: May 8, 2006 : Att.Dkt:PAICE201.DIV.3  
 For: Hybrid Vehicles

Mail Stop Issue Fee  
 Hon. Commissioner for Patents  
 P.O. Box 1450  
 Alexandria VA 22313-1450

RESPONSE TO NOTICE TO FILE CORRECTED APPLICATION PAPERS

Sir:

In response to the Notice to File Corrected Application Papers mailed October 6, 2008 (copy enclosed), which included an Identification of Drawing Deficiencies mentioning errors in Figs. 3 and 14 of this application, clean, corrected copies of these two drawings are submitted herewith. The application having already been allowed, prompt issuance of the patent is earnestly solicited.

Respectfully submitted,

Oct. 13, 2008

Michael de Angeli  
 Reg. No. 27,869  
 60 Intrepid Lane  
 Jamestown, RI 02835  
 401-423-3190



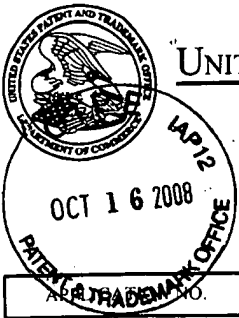

UNITED STATES PATENT AND TRADEMARK OFFICE

UNITED STATES DEPARTMENT OF COMMERCE  
United States Patent and Trademark Office  
Address: COMMISSIONER FOR PATENTS  
P.O. Box 1450  
Alexandria, Virginia 22313-1450  
www.uspto.gov

APP. NO.	FILING DATE	FIRST NAMED INVENTOR	ATTORNEY DOCKET NO.	CONFIRMATION NO.
11/429,457	05/08/2006	Alex J. Severinsky	PAICE201.DIV.3	1951

7590 10/06/2008  
Michael de Angeli  
60 Intrepid Lane  
Jamestown, RI 02835

EXAMINER  
COLLADO, CYNTHIA FRANCISCA

ART UNIT 3618 PAPER NUMBER

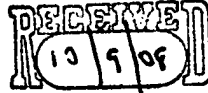

MAIL DATE 10/06/2008 DELIVERY MODE PAPER

Please find below and/or attached an Office communication concerning this application or proceeding.

The time period for reply, if any, is set in the attached communication.



UNITED STATES PATENT AND TRADEMARK OFFICE

Commissioner for Patents  
United States Patent and Trademark Office  
P.O. Box 1450  
Alexandria, VA 22313-1450  
www.uspto.gov

Serial No. : 11/429,457  
Applicant : SEVERIN-  
SKY  
Filing Date : 05/08/2006  
Date of Notice : 10/06/2008

## NOTICE TO FILE CORRECTED APPLICATION PAPERS

### *Notice of Allowance Mailed*

This application has been accorded an Allowance Date and is being prepared for issuance. The application, however, is incomplete for the reasons below.

Applicant is given 2 months from the date of this Notice within which to correct the informalities indicated below. If the informality pertains to the abstract, specification (including claims) or drawings, the informality must be corrected with an amendment in compliance with 37 CFR 1.121 (or, if the application is a reissue application, 37 CFR 1.173). Such an amendment may be filed after payment of the issue fee if limited to correction of informalities noted herein. See Waiver of 37 CFR 1.312 for Documents Required by the Office of Patent Publication, 1280 Off. Gaz. Patent Office 918 (March 23, 2004). In addition, if the informality is not corrected until after payment of the issue fee, for purposes of 35 U.S.C. 154(b)(1)(iv), "all outstanding requirements" will be considered to have been satisfied when the informality has been corrected. A failure to reply will result in the application being ABANDONED. **This period for reply is NOT extendable under 37 CFR 1.136(a).**

See attachment.

*A copy of this notice **MUST** be returned with the reply. Please address response to  
"Mail Stop Issue Fee, Commissioner for Patents,  
P.O. Box 1450, Alexandria, VA 22313-1450".*

*Registered users of EFS-Web may alternatively submit their reply to this notice via EFS-Web.*

/Diane Terry/  
Diane Terry  
Office of Data Management  
Phone: 703-308-9250, ext. 150



Application No. 11429457

Drawings filed 5-8-2006

### IDENTIFICATION OF DRAWING DEFICIENCIES

- The character of the lines, numbers, and letters is poor. FIG(s) 14
- There is a hole or the image thereof within the illustration. FIG(s) \_\_\_\_\_
- An ink stamp or the image thereof obscures part of the illustration. FIG(s) \_\_\_\_\_
- The illustration is penetrated or traversed by a solid or broken line that is not intended to be part of the drawing, such as a dark line caused by a flaw in the copying process. FIG(s) \_\_\_\_\_
- The drawing is marred by black smudges, obliterations, or fax/copier marks (for example, speckles or dots in a substantial portion of the drawing). FIG(s) \_\_\_\_\_
- Figure numbers are duplicated or missing. FIG(s) \_\_\_\_\_
- Drawing sheet or figure is missing. FIG(s) \_\_\_\_\_
- Numbers, letters, or reference characters in the drawing have been crossed out or are illegibly handwritten. FIG(s) 3
- The drawing's background shows that the original drawing was made on graph paper or other paper with a pattern or decoration. FIG(s) \_\_\_\_\_
- The FIG. number label is placed in a location that causes the drawing to be read upside down. FIG(s) \_\_\_\_\_
- Data, a reference number, or part of the drawing is truncated or missing, or a lead line has no reference number. FIG(s) \_\_\_\_\_
- The drawing is continued onto a second page (or more) without proper labeling under 37 CFR 1.84(u)(1). FIG(s) \_\_\_\_\_
- The drawing and/or the FIG. label contain(s) foreign language. FIG(s) \_\_\_\_\_
- Color drawings are present in this application but the following 37 CFR 1.84(a) requirements have not been met\*:
  - Petition explaining why color drawings are necessary
  - Petition fee set forth in § 1.17(h)
  - Three (3) sets of color drawings
  - Color drawing paragraph in specification

\*If color drawings are not elected, then applicant **must respond** so stating. Also, references to color drawings in the specification, if any, must be amended.

COMMENTS: ID number located under no. 122 is unreadable (62 0764)







APPLICATION NO.	ISSUE DATE	PATENT NO.	ATTORNEY DOCKET NO.	CONFIRMATION NO.
11/429,457	11/25/2008	7455134	PAICE201.DIV.3	1951

7590 11/05/2008

Michael de Angeli  
60 Intrepid Lane  
Jamestown, RI 02835

### ISSUE NOTIFICATION

The projected patent number and issue date are specified above.

#### **Determination of Patent Term Adjustment under 35 U.S.C. 154 (b)** (application filed on or after May 29, 2000)

The Patent Term Adjustment is 384 day(s). Any patent to issue from the above-identified application will include an indication of the adjustment on the front page.

If a Continued Prosecution Application (CPA) was filed in the above-identified application, the filing date that determines Patent Term Adjustment is the filing date of the most recent CPA.

Applicant will be able to obtain more detailed information by accessing the Patent Application Information Retrieval (PAIR) WEB site (<http://pair.uspto.gov>).

Any questions regarding the Patent Term Extension or Adjustment determination should be directed to the Office of Patent Legal Administration at (571)-272-7702. Questions relating to issue and publication fee payments should be directed to the Customer Service Center of the Office of Patent Publication at (571)-272-4200.

APPLICANT(s) (Please see PAIR WEB site <http://pair.uspto.gov> for additional applicants):

Alex J. Severinsky, Washington, DC;  
Theodore Louckes, Holly, MI;



IFW

IN THE UNITED STATES PATENT AND TRADEMARK OFFICE

Applicant: Severinsky et al : Ser. No. 11/429,457  
 Patent No.: 7,455,134 : Filed: May 8, 2006  
 Issued: November 25, 2008 : Atty. Dkt.: PAICE201.DIV.3  
 For: Hybrid Vehicles

CHANGE OF CORRESPONDENCE ADDRESS

Hon. Commissioner for Patents  
 P. O. Box 1450  
 Alexandria VA 22313-1450

Sir:

Effective November 15, 2011, kindly change the address for correspondence concerning this patent to the following:

Michael de Angeli  
 34 Court Street  
 Jamestown RI 02835

Tel: 401-423-3190  
 Fax: 401-423-3191  
 Email: Mdeangeli20@gmail.com

Thank you for your attention to this matter.

Respectfully submitted,

Michael de Angeli  
 Reg. No. 27,869  
 60 Intrepid Lane  
 Jamestown RI 02835  
 401-423-3190

Dated: 11/15/11

AO 120 (Rev. 08/10)

TO: <b>Mail Stop 8</b> <b>Director of the U.S. Patent and Trademark Office</b> P.O. Box 1450 Alexandria, VA 22313-1450	<b>REPORT ON THE                  FILING OR DETERMINATION OF AN                  ACTION REGARDING A PATENT OR                  TRADEMARK</b>
---	--

In Compliance with 35 U.S.C. § 290 and/or 15 U.S.C. § 1116 you are hereby advised that a court action has been filed in the U.S. District Court \_\_\_\_\_ for the District of Maryland Baltimore Division \_\_\_\_\_ on the following  
 Trademarks or  Patents. (  the patent action involves 35 U.S.C. § 292.):

DOCKET NO. 1:14-cv-00492-WDQ	DATE FILED 2/19/2014	U.S. DISTRICT COURT for the District of Maryland Baltimore Division
PLAINTIFF Paice LLC and The Abell Foundation, Inc.		DEFENDANT Ford Motor Company
PATENT OR TRADEMARK NO.	DATE OF PATENT OR TRADEMARK	HOLDER OF PATENT OR TRADEMARK
1 7,237,634	7/3/2007	Paice LLC and The Abell Foundation, Inc.
2 7,104,347	9/12/2006	Paice LLC and The Abell Foundation, Inc.
3 7,559,388	7/14/2009	Paice LLC and The Abell Foundation, Inc.
4 8,214,097	7/3/2012	Paice LLC and The Abell Foundation, Inc.
5 7,455,134	11/25/2008	Paice LLC and The Abell Foundation, Inc.

In the above—entitled case, the following patent(s)/ trademark(s) have been included:

DATE INCLUDED	INCLUDED BY <input type="checkbox"/> Amendment <input type="checkbox"/> Answer <input type="checkbox"/> Cross Bill <input type="checkbox"/> Other Pleading		
PATENT OR TRADEMARK NO.	DATE OF PATENT OR TRADEMARK	HOLDER OF PATENT OR TRADEMARK	
1			
2			
3			
4			
5			

In the above—entitled case, the following decision has been rendered or judgement issued:

DECISION/JUDGEMENT
--------------------

CLERK	(BY) DEPUTY CLERK	DATE
-------	-------------------	------

Copy 1—Upon initiation of action, mail this copy to Director Copy 3—Upon termination of action, mail this copy to Director  
 Copy 2—Upon filing document adding patent(s), mail this copy to Director Copy 4—Case file copy