



(12) **United States Patent**
Gopalraja et al.

(10) **Patent No.:** **US 6,277,249 B1**
(45) **Date of Patent:** **Aug. 21, 2001**

(54) **INTEGRATED PROCESS FOR COPPER VIA FILLING USING A MAGNETRON AND TARGET PRODUCING HIGHLY ENERGETIC IONS**

FOREIGN PATENT DOCUMENTS

WO 00/48226
A1 8/2000 (WO) H01J/37/34

OTHER PUBLICATIONS

Kitamoto et al., "Compact sputtering apparatus for depositing Co-Cr alloy thin films in magnetic disk," Proceedings: The Fourth International Symposium on Sputtering & Plasma Processes, Kanazawa, Japan, Jun. 4-6, 1997, pp. 519-522.

(List continued on next page.)

(75) Inventors: **Praburam Gopalraja**, Sunnyvale; **Jianming Fu**, San Jose; **Fusen Chen**, Saratoga; **Girish Dixit**, San Jose; **Zheng Xu**, Foster City; **Sankaram Athreya**, Sunnyvale; **Wei D. Wang**, Santa Clara; **Ashok K. Sinha**, Palo Alto, all of CA (US)

(73) Assignee: **Applied Materials Inc.**, Santa Clara, CA (US)

(*) Notice: Subject to any disclaimer, the term of this patent is extended or adjusted under 35 U.S.C. 154(b) by 0 days.

Primary Examiner—Mark F. Huff
Assistant Examiner—Daborah Chacko-Davis
(74) *Attorney, Agent, or Firm*—Charles S. Guenzer

(21) Appl. No.: **09/518,180**

(22) Filed: **Mar. 2, 2000**

(57) **ABSTRACT**

A target and magnetron for a plasma sputter reactor. The target has an annular trough facing the wafer to be sputter coated. Various types of magnetic means positioned around the trough create a magnetic field supporting a plasma extending over a large volume of the trough. For example, the magnetic means may include magnets disposed on one side within a radially inner wall of the trough and on another side outside of a radially outer wall of the trough to create a magnetic field extending across the trough, to thereby support a high-density plasma extending from the top to the bottom of the trough. The large plasma volume increases the probability that the sputtered metal atoms will become ionized. The magnetic means may include a magnetic coil, may include additional magnets in back of the trough top wall to increase sputtering there, and may include confinement magnets near the bottom of the trough sidewalls. The magnets in back of the top wall may have an outer magnet surrounding an inner magnet of the opposite polarity. The high aspect ratio of the trough also reduces asymmetry in coating the sidewalls of a deep hole at the edge of the wafer. An integrated copper via filling process includes a first step of highly ionized sputter deposition of copper, a second step of more neutral, lower-energy sputter deposition of copper to complete the seed layer, and electroplating copper into the hole to complete the metallization.

Related U.S. Application Data

(63) Continuation-in-part of application No. 09/490,026, filed on Jan. 21, 2000.

(51) **Int. Cl.**⁷ **C23C 14/35**; C23C 14/00; C23C 14/34

(52) **U.S. Cl.** **204/192.12**; 204/298.19; 204/298.2; 204/298.21; 204/298.22; 204/298.16; 204/298.17; 204/298.18; 204/298.12; 204/192.17; 204/192.15

(58) **Field of Search** 204/298.19, 298.2, 204/298.21, 298.22, 298.16, 298.17, 298.18, 298.12, 192.12, 192.15, 192.17

(56) **References Cited**

U.S. PATENT DOCUMENTS

5,069,770 * 12/1991 Glocker 204/192.12
5,178,739 1/1993 Barnes et al. 204/192.12
5,482,611 1/1996 Helmer et al. 204/298.17

(List continued on next page.)

27 Claims, 11 Drawing Sheets

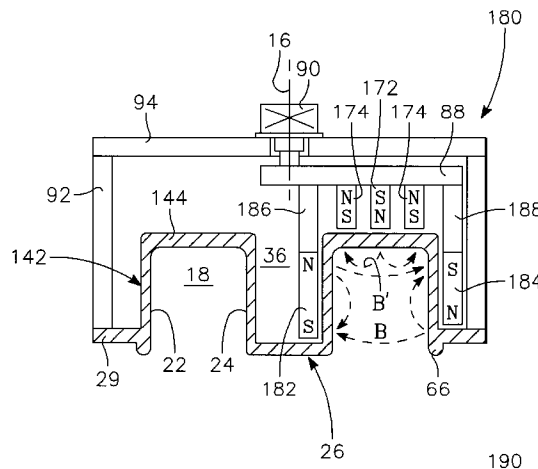

INTEL 1009

U.S. PATENT DOCUMENTS

5,512,150	*	4/1996	Bourez et al.	204/298.19
5,589,041		12/1996	Lantsman	204/192.33
5,685,959	*	11/1997	Bourez et al.	204/298.2
5,685,961		11/1997	Bourez et al.	204/192.2
5,865,961		2/1999	Yokoyama	204/192.12
5,897,752	*	4/1999	Hong et al.	204/192.12
6,080,284		6/2000	Miyaura	204/192.12

OTHER PUBLICATIONS

Yamazato et al., "Preparation of TiN thin Films by facing targets magnetron sputtering," Proceedings: The Fourth International Symposium on Sputtering & Plasma Processes, Kanazawa, Japan Jun. 4-6, 1997, pp. 635-638.

Musil et al., "Unbalanced magnetrons and new sputtering systems with enhanced plasma ionization," *Journal of Vacuum Science and Technology A*, vol. 9, No. 3, May/Jun. 1991, pp. 1171-1177.

Matsuoka et al., "Dense plasma production and film deposition by new high-rate sputtering using an electric mirror," *Journal of Vacuum Science and Technology A*, vol. 7, No. 4, Jul./Aug. 1989, pp. 2652-2657.

Ivanov et al., "Electron energy distribution function in dc magnetron sputtering discharge," *Vacuum*, vol. 43, No. 8, 1992, pp. 837-842.

* cited by examiner

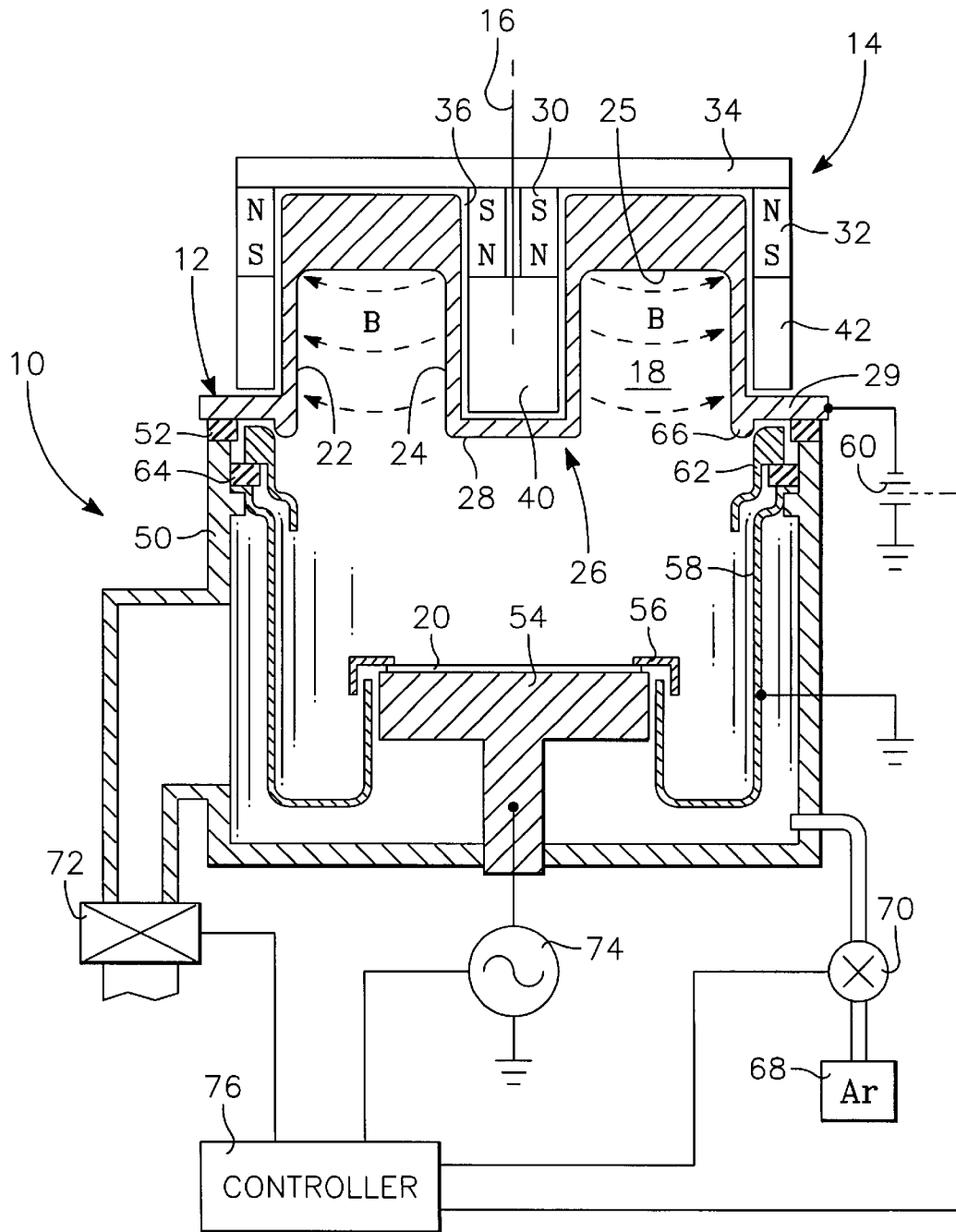

FIG. 1

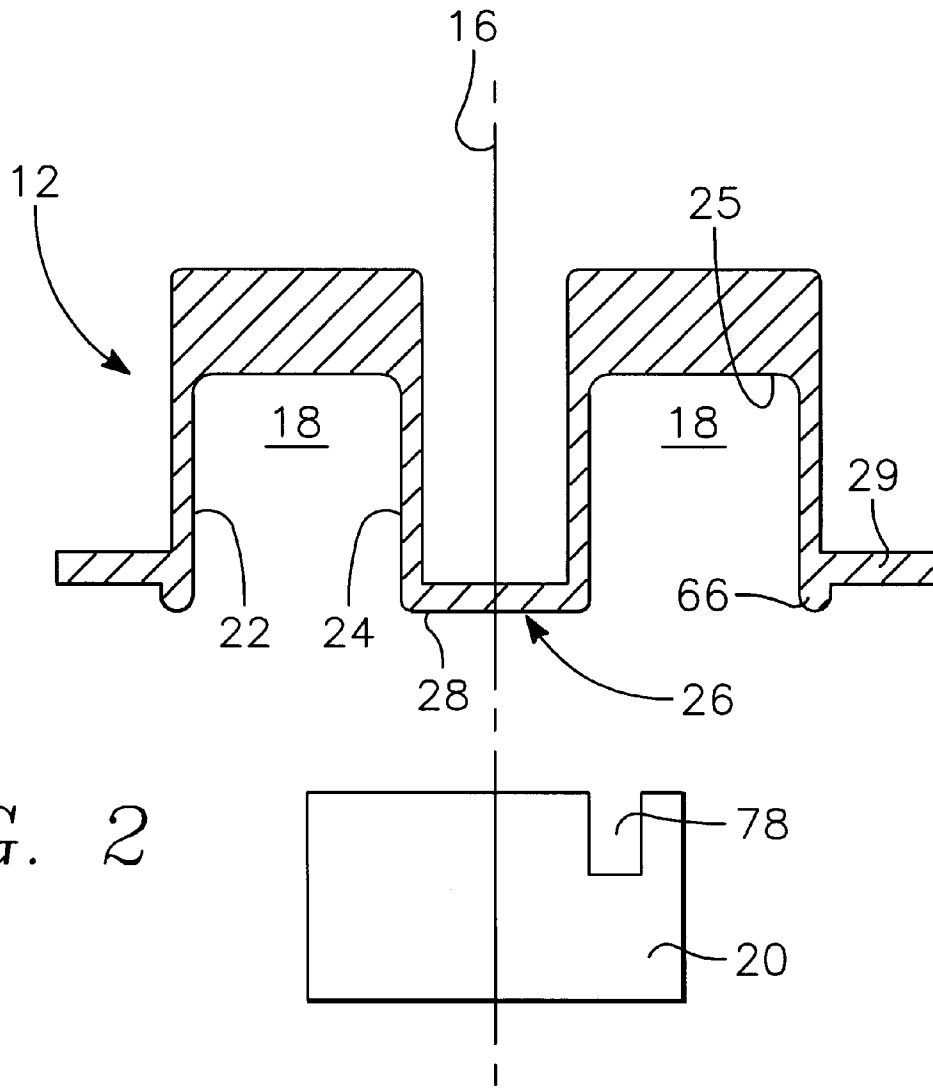

FIG. 2

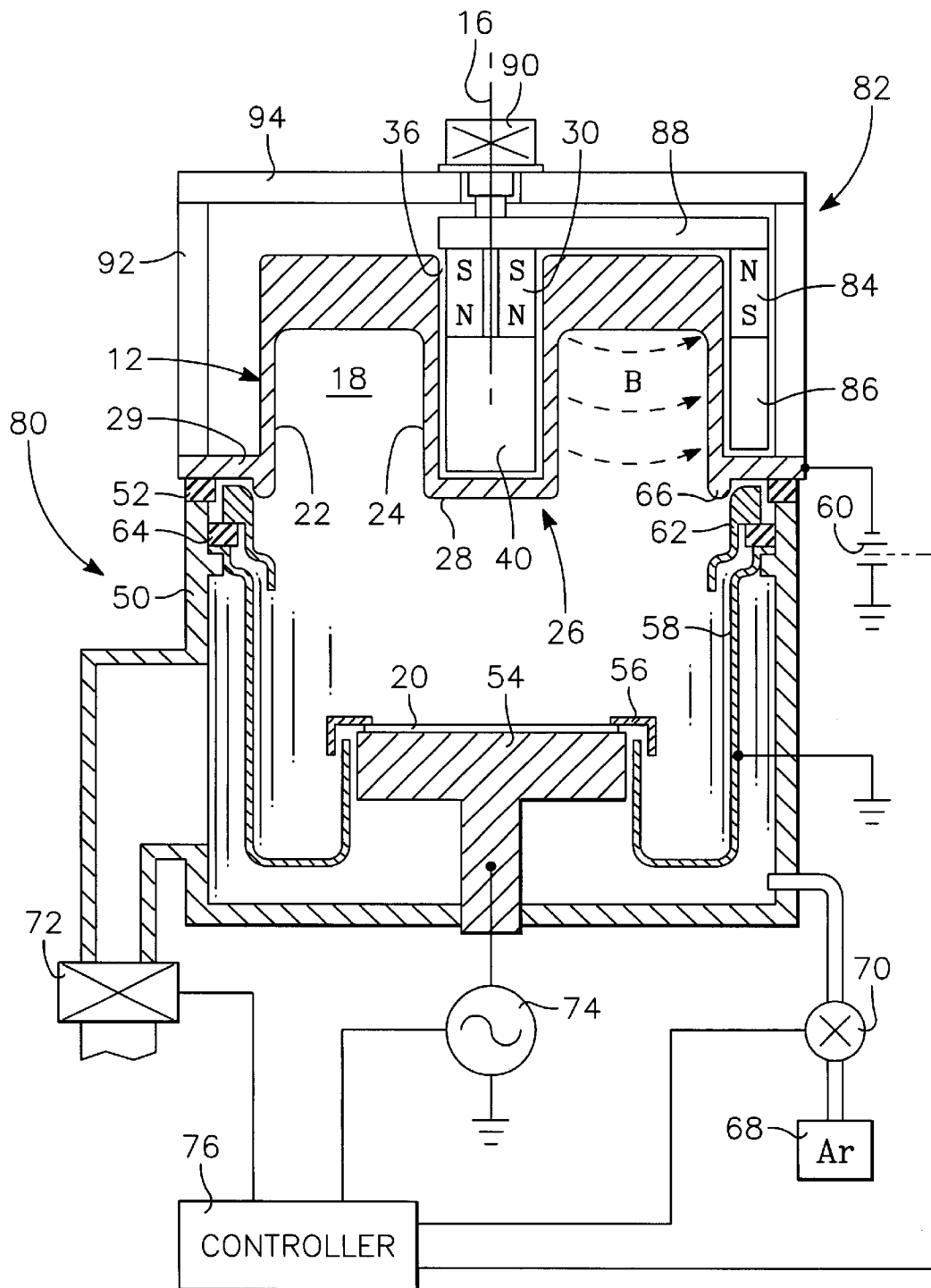

FIG. 3

Explore Litigation Insights

Docket Alarm provides insights to develop a more informed litigation strategy and the peace of mind of knowing you're on top of things.

Real-Time Litigation Alerts



Keep your litigation team up-to-date with **real-time alerts** and advanced team management tools built for the enterprise, all while greatly reducing PACER spend.

Our comprehensive service means we can handle Federal, State, and Administrative courts across the country.

Advanced Docket Research



With over 230 million records, Docket Alarm's cloud-native docket research platform finds what other services can't. Coverage includes Federal, State, plus PTAB, TTAB, ITC and NLRB decisions, all in one place.

Identify arguments that have been successful in the past with full text, pinpoint searching. Link to case law cited within any court document via Fastcase.

Analytics At Your Fingertips



Learn what happened the last time a particular judge, opposing counsel or company faced cases similar to yours.

Advanced out-of-the-box PTAB and TTAB analytics are always at your fingertips.

API

Docket Alarm offers a powerful API (application programming interface) to developers that want to integrate case filings into their apps.

LAW FIRMS

Build custom dashboards for your attorneys and clients with live data direct from the court.

Automate many repetitive legal tasks like conflict checks, document management, and marketing.

FINANCIAL INSTITUTIONS

Litigation and bankruptcy checks for companies and debtors.

E-DISCOVERY AND LEGAL VENDORS

Sync your system to PACER to automate legal marketing.