



US008023580B2

(12) **United States Patent**
Bremer

(10) **Patent No.:** **US 8,023,580 B2**
(45) **Date of Patent:** **Sep. 20, 2011**

(54) **SYSTEM AND METHOD OF COMMUNICATION USING AT LEAST TWO MODULATION METHODS**

(76) Inventor: **Gordon F. Bremer**, Clearwater, FL (US)

(*) Notice: Subject to any disclaimer, the term of this patent is extended or adjusted under 35 U.S.C. 154(b) by 0 days.

(21) Appl. No.: **12/543,910**

(22) Filed: **Aug. 19, 2009**

(65) **Prior Publication Data**

US 2010/0183055 A1 Jul. 22, 2010

Related U.S. Application Data

(63) Continuation of application No. 11/774,803, filed on Jul. 9, 2007, now Pat. No. 7,675,965, which is a continuation of application No. 10/412,878, filed on Apr. 14, 2003, now Pat. No. 7,248,626, which is a continuation-in-part of application No. 09/205,205, filed on Dec. 4, 1998, now Pat. No. 6,614,838.

(60) Provisional application No. 60/067,562, filed on Dec. 5, 1997.

(51) **Int. Cl.**
H04L 5/12 (2006.01)

(52) **U.S. Cl.** **375/261**; 455/102; 332/108; 332/119; 332/151

(58) **Field of Classification Search** **375/261**, 375/269, 285, 222, 298, 302, 305, 308; 455/102, 455/110; 332/108, 119, 120, 151
See application file for complete search history.

(56) **References Cited**

U.S. PATENT DOCUMENTS

3,736,528 A 5/1973 Acker et al.
3,761,840 A 9/1973 Bremer
3,970,926 A 7/1976 Rigby et al.

4,091,422 A 5/1978 Amster
4,335,464 A 6/1982 Armstrong et al.
4,381,546 A 4/1983 Armstrong
4,464,767 A 8/1984 Bremer
4,503,545 A 3/1985 Bremer et al.
4,509,171 A 4/1985 Bremer et al.
4,516,216 A 5/1985 Armstrong
4,525,846 A 6/1985 Bremer et al.
4,525,847 A 6/1985 Bremer
4,532,640 A 7/1985 Bremer et al.
4,630,286 A 12/1986 Betts
4,645,871 A 2/1987 Bremer et al.
4,654,807 A 3/1987 Bremer
4,663,766 A 5/1987 Bremer
4,677,625 A 6/1987 Betts et al.
4,782,498 A 11/1988 Copeland, III

(Continued)

OTHER PUBLICATIONS

“Conelrad Emergency Radio Notification System Born in 1951”, www.modestoradiomuseum.org, Accessed on Dec. 5, 2010, 2 pages.

(Continued)

Primary Examiner — Dac Ha
(74) *Attorney, Agent, or Firm* — Condo Roccia LLP

(57) **ABSTRACT**

A device may be capable of communicating using at least two type types of modulation methods. The device may include a transceiver capable of acting as a master according to a master/slave relationship in which communication from a slave to a master occurs in response to communication from the master to the slave. The master transceiver may send transmissions discrete transmissions structured with a first portion and a payload portion. Information in the first portion may be modulated according to a first modulation method and indicate an impending change to a second modulation method, which is used for transmitting the payload portion. The discrete transmissions may be addressed for an intended destination of the payload portion.

79 Claims, 8 Drawing Sheets

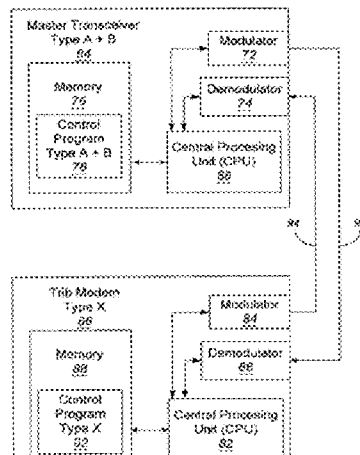

Samsung Ex. 1201
(Samsung v. Rembrandt)

U.S. PATENT DOCUMENTS							
4,811,357	A	3/1989	Betts et al.	5,999,563	A	12/1999	Polley et al.
4,862,464	A	8/1989	Betts et al.	6,011,814	A	1/2000	Martinez et al.
4,924,516	A	5/1990	Bremer et al.	6,021,158	A	2/2000	Schurr et al.
4,926,448	A	5/1990	Kraul et al.	6,031,897	A	2/2000	Bremer et al.
4,939,748	A	7/1990	Betts et al.	6,061,392	A	5/2000	Bremer et al.
5,008,903	A	4/1991	Betts et al.	6,067,297	A	5/2000	Beach
5,050,536	A	9/1991	Baker	6,072,779	A	6/2000	Tzannes et al.
5,081,647	A	1/1992	Bremer	6,075,512	A	6/2000	Patel et al.
5,099,478	A	3/1992	Bremer et al.	6,097,858	A	8/2000	Laor
5,168,535	A	12/1992	Laor	6,097,860	A	8/2000	Laor
5,206,854	A	4/1993	Betts et al.	6,101,299	A	8/2000	Laor
5,230,010	A	7/1993	Betts et al.	6,108,347	A	8/2000	Holmquist
5,239,306	A	8/1993	Siwiak et al.	6,111,936	A	8/2000	Bremer
5,239,607	A	8/1993	Da Silva et al.	6,125,148	A	9/2000	Frodigh et al. 375/261
5,251,236	A	10/1993	Brehmer et al.	6,134,245	A	10/2000	Scarmalis
5,251,328	A	10/1993	Shaw	6,154,524	A	11/2000	Bremer
5,257,396	A	10/1993	Auld, Jr. et al.	6,157,680	A	12/2000	Betts et al.
5,280,503	A	1/1994	Betts et al.	6,160,790	A	12/2000	Bremer
5,311,557	A	5/1994	Betts et al.	6,175,436	B1	1/2001	Jackel
5,311,578	A	5/1994	Bremer et al.	6,185,083	B1	2/2001	Mathieu et al.
5,345,332	A	9/1994	Da Silva et al.	6,212,227	B1	4/2001	Ko et al.
5,355,362	A	10/1994	Gorshe et al.	6,236,481	B1	5/2001	Laor
5,373,149	A	12/1994	Rasmussen	6,236,717	B1	5/2001	Bremer et al.
5,392,154	A	2/1995	Chang et al.	6,243,391	B1	6/2001	Holmquist
5,412,651	A	5/1995	Gorshe	6,252,644	B1	6/2001	Patel
5,414,540	A	5/1995	Patel et al.	6,272,108	B1	8/2001	Chapman
5,436,930	A	7/1995	Bremer et al.	6,272,154	B1	8/2001	Bala et al.
5,444,704	A	8/1995	Henderson et al.	6,292,281	B1	9/2001	Bala et al.
5,448,555	A	9/1995	Bremer et al.	6,307,653	B1	10/2001	Bala et al.
5,473,675	A	12/1995	Chapman et al.	6,307,893	B1	10/2001	Bremer et al.
5,475,713	A	12/1995	Bremer et al.	6,307,923	B1	10/2001	Bremer et al.
5,506,866	A	4/1996	Bremer et al.	6,320,879	B1	11/2001	Bremer
5,513,212	A	4/1996	Bremer	6,320,993	B1	11/2001	Laor
5,513,213	A	4/1996	Patel et al.	6,330,275	B1	12/2001	Bremer
5,521,942	A	5/1996	Betts et al.	6,335,992	B1	1/2002	Bala et al.
5,530,718	A	6/1996	Gradeler et al.	6,347,008	B1	2/2002	Vodhanel
5,537,398	A	7/1996	Siwiak	6,348,986	B1	2/2002	Doucet et al.
5,537,411	A	7/1996	Plas	6,408,056	B1	6/2002	Bremer et al.
5,540,456	A	7/1996	Meier-Burkamp et al.	6,445,733	B1	9/2002	Zuranski et al.
5,548,222	A	8/1996	Jensen et al.	6,470,110	B1	10/2002	Lin
5,550,881	A	8/1996	Sridhar et al. 375/377	6,480,645	B1	11/2002	Peale et al.
5,559,791	A	9/1996	Bremer et al.	6,493,475	B1	12/2002	Lin
5,559,792	A	9/1996	Bottoms et al.	6,529,652	B1	3/2003	Bremer
5,559,810	A	9/1996	Gilbert et al. 714/704	6,535,589	B1	3/2003	Nauman et al.
5,563,883	A	10/1996	Cheng	6,546,090	B1	4/2003	Bremer et al.
5,570,295	A	10/1996	Isenberg et al.	6,549,692	B1	4/2003	Harel et al.
5,577,087	A	11/1996	Furuya	6,556,540	B1	4/2003	Mawhinney et al.
5,602,869	A	2/1997	Scott	6,580,709	B1	6/2003	Gorshe et al.
5,629,992	A	5/1997	Amersfoort	6,580,785	B2	6/2003	Bremer et al.
5,642,379	A	6/1997	Bremer et al.	6,591,029	B1	7/2003	Lin et al.
5,651,114	A	7/1997	Davidson, Jr.	6,597,827	B1	7/2003	Bremer et al.
5,661,718	A	8/1997	Bremer et al.	6,603,894	B1	8/2003	Pu
5,671,250	A	9/1997	Bremer et al.	6,614,838	B1	9/2003	Bremer
5,684,825	A	11/1997	Ko	6,628,857	B1	9/2003	Bonadeo et al.
5,684,834	A	11/1997	Betts et al.	6,631,119	B1	10/2003	Mawhinney et al.
5,711,012	A	1/1998	Bottoms et al.	6,633,693	B1	10/2003	Peale et al.
5,719,922	A	2/1998	Bremer et al.	6,647,058	B1	11/2003	Bremer et al.
5,719,923	A	2/1998	Bremer et al.	6,658,096	B2	12/2003	Bremer et al.
5,748,811	A	5/1998	Amersfoort et al.	6,671,328	B1	12/2003	Poon et al.
5,764,699	A	6/1998	Needham et al. 375/261	6,690,644	B1	2/2004	Gorshe
5,793,800	A	8/1998	Jylha et al.	6,690,849	B1	2/2004	Dadap, Jr. et al.
5,805,669	A	9/1998	Bingel et al.	6,715,124	B1	3/2004	Betts
5,805,755	A	9/1998	Amersfoort et al.	6,744,883	B1	6/2004	Bingel et al.
5,812,537	A	9/1998	Betts et al.	6,771,740	B1	8/2004	Bingel
5,825,517	A	10/1998	Antoniades et al.	6,775,355	B1	8/2004	Bingel et al.
5,828,657	A	10/1998	Betts et al.	6,782,094	B1	8/2004	Venz et al.
5,841,500	A	11/1998	Patel	6,782,096	B1	8/2004	Bremer et al.
5,844,944	A	12/1998	Betts et al.	6,885,730	B1	4/2005	Bremer
5,859,877	A	1/1999	Betts et al.	6,922,415	B1	7/2005	Bremer et al.
5,881,047	A	3/1999	Bremer et al.	6,950,444	B1	9/2005	Holmquist et al.
5,881,142	A	3/1999	Frankel et al.	6,970,501	B1	11/2005	Bremer et al.
5,901,205	A	5/1999	Smith et al.	7,006,445	B1	2/2006	Cole et al.
5,915,003	A	6/1999	Bremer et al.	7,013,421	B2	3/2006	Betts
5,936,949	A	8/1999	Pasternak et al.	7,020,266	B2	3/2006	Bremer et al.
5,940,438	A	8/1999	Poon et al. 375/222	7,023,829	B1	4/2006	Holmquist et al.
				7,035,380	B1	4/2006	Bingel et al.
				7,046,798	B2	5/2006	Betts et al.

7,127,048 B2 10/2006 Bremer et al.
 7,130,338 B2 10/2006 Bremer et al.
 7,155,016 B1 12/2006 Betts et al.
 7,170,867 B2 1/2007 O'Toole et al.
 7,248,626 B2 7/2007 Bremer
 7,272,215 B2 9/2007 Bremer et al.
 7,289,604 B2 10/2007 Bremer
 7,289,610 B2 10/2007 Bremer et al.
 7,352,803 B2 4/2008 Bremer et al.
 7,471,777 B2 12/2008 Bremer et al.
 7,675,965 B2 3/2010 Bremer
 7,707,446 B2 4/2010 Bremer et al.
 7,711,109 B2 5/2010 Betts et al.
 7,747,000 B2 6/2010 Bremer et al.
 2001/0022836 A1 9/2001 Bremer et al.
 2002/0041662 A1 4/2002 Bremer et al.
 2002/0167949 A1 11/2002 Bremer et al.
 2003/0039348 A1 2/2003 Bremer et al.
 2003/0210773 A1 11/2003 Bremer et al.
 2003/0210779 A1 11/2003 Bremer et al.
 2004/0013183 A1 1/2004 Bremer
 2004/0042510 A1 3/2004 Bremer et al.
 2004/0052361 A1 3/2004 Betts et al.
 2004/0066929 A1 4/2004 Bremer et al.
 2004/0081233 A1 4/2004 Bremer et al.
 2004/0179662 A1 9/2004 Bremer et al.
 2004/0213170 A1 10/2004 Bremer et al.
 2004/0258236 A1 12/2004 Bremer et al.
 2005/0025153 A1 2/2005 Bremer et al.
 2005/0074057 A1 4/2005 Bremer et al.
 2005/0147158 A1 7/2005 Bremer et al.
 2005/0152404 A1 7/2005 Holmquist et al.
 2005/0163303 A1 7/2005 Bremer
 2005/0180545 A1 8/2005 Bremer et al.
 2006/0188088 A1 8/2006 Bingel et al.
 2006/0193465 A1 8/2006 Betts
 2006/0195712 A1 8/2006 Bremer et al.
 2007/0047730 A1 3/2007 Bremer
 2007/0047733 A1 3/2007 Bremer
 2007/0286187 A1 12/2007 Bremer
 2008/0013608 A1 1/2008 Bremer
 2008/0019432 A1 1/2008 Bremer et al.
 2009/0111422 A1 4/2009 Bremer
 2009/0262911 A1 10/2009 Bremer
 2009/0262912 A1 10/2009 Bremer
 2010/0183055 A1 7/2010 Bremer
 2010/0246598 A1 9/2010 Bremer

OTHER PUBLICATIONS

"Emergency Alert System", Public Safety and Homeland Security Bureau, www.fcc.gov/pshs/services/eas, Accessed on Dec. 5, 2010, 2 pages.

"Specialized Communications Techniques for the Radio Amateur", The American Radio Relay League, Inc., 1975, 1st Edition, Chapter 4, 78-83.

"Specialized Communications Techniques for the Radio Amateur", The American Radio Relay League, Inc., 1975, 1st Edition, Chapter 5, 99-113.

Bates (Ed.), "Broadband Telecommunications Handbook", McGraw-Hill Publishing, NY, 2000, Chapter 9, 128, 129, 131, 132, 133 and 134.

Benson (Ed.), "Television Engineering Handbook", McGraw-Hill Publishers, NY, 1992, 5 pages, 4.14, 4.15, 4.24, 4.34 and 4.35.

Bluetooth®, "Specification of the Bluetooth System, Master Table of Contents & Compliance Requirements", Specification vol. 0, Nov. 4, 2004, V2.0, 1-1230.

Bluetooth™, "Specification of the Bluetooth System, Core", Dec. 1, 1999, V1.0B, 1-1082.

Bluetooth™M, "Specification of the Bluetooth System, Profiles", Specification vol. 2, Dec. 1, 1999, V1.0B, 1-440.

Chorafas (Ed.), "Telephony: Today and Tomorrow", Prentice-Hall, Inc., NJ, Chapter 15, 1984, 191-197.

Freeman (Ed.), "Telecommunications Systems Engineering: Analog and Digital Network Design", John Wiley and Sons, Inc., NY, 1980, 1 page, 180.

Goodman (Ed.), "Radio Amateur's Handbook", The American Radio Relay League, Inc., CN, 1965, Chapter 10, 291-295.

Green (Ed.), "RTTY Handbook", Tab Books, Chapter 4, 1972, 266-273.

IEEE Information Technology, "Wireless LAN Medium Access Control (MAC) and Physical Layer (PHY) Specifications", 1997, 1-466.

Jurgen (Ed.), "Digital Consumer Electronics Handbook", McGraw-Hill Publications, NY, 1997, 27.7-27.10.

Kuecken (Ed.), "Talking Computers and Telecommunications", Van Nostrand Reinhold Company, Inc., NY, 1983, 32-36.

Margulies (Ed.), "SCSA Book", Telecom Library, Inc., NJ, Chapter 8, 1993, 250.

Martin (Ed.), "Telecommunications and The Computer", Prentice-Hall, Inc., NJ, 2nd Edition, Chapter 21, 1976, 410-423.

Mazda (Ed.), "Electronics Engineer's Reference Book", 5th Edition, Butterworth and Company Publishers, London, 1983, 54.5-54.8.

Newton (Ed.), "Newton's Telecom Dictionary", Flatiron Publications, Inc., NY, Apr. 1994, 7th Edition, 9, 363, 364, 426, 427, 428, 429 and 430.

Pallott and Miller, "Implementing Message Priority Polices Over an 802.11 Based Mobile Ad Hoc Network", IEEE, Military Communications Conference, 2001, MILCOM 2001, Communications for Network-Centric Operations: Creating the Information Force, Oct. 28-31, 2001, 2, 860-864.

The National Association for Amateur Radio (ARRL), Radioteletype (RTTY), "Basic Principles and Machines", Chapter 2.1, Book or Journal Title Unknown, Date Unknown, pp. 13 and 14.

The National Association for Amateur Radio (ARRL), Radioteletype (RTTY), "Autostart", Chapter 3.4, "references", Chapter 8, Book or Journal Title Unknown, Date Unknown, pp. 107-111, 183, 185, 186 and 187.

Rzeszewski (Ed.), "Color Television", IEEE Press, John Wiley and Sons, Inc, NY, 1983, 3, 8 and 9.

Shrader (Ed.), "Electronic Communication", 1959, McGraw-Hill Publishers, NY, 551-555.

Shrader (Ed.), "Electronic Communication", 1959, McGraw-Hill Publishers, NY, 519.

Third Generation Partnership Project (3GPP)—Technologies Web Page, <http://www.3gpp.org/technologies->, Accessed on Feb. 8, 2011, 2 pages.

Vilips (Ed.), "Data Modem: Selection and Evaluation Guide", Artech House, Inc, MA, Section 1, 1972, 3 pages.

Wilson et al (Ed.), "The ARRL Handbook for Radio Communications", 64th Edition, The American Radio Relay League, Inc., Chapter 19, 1986, 19-9-19-13.

Wilson et al. (Ed.), "The ARRL Handbook for Radio Communications", 85th Edition, The American Radio Relay League, Chapter 9, 2008, 9.32, 9.33 and 9.34.

Wilson et al. (Ed.), "The ARRL Handbook for Radio Communications", 64th Edition, The American Radio Relay League Inc., Chapter 14, 1986, 14-13 and 14-14.

International Telecommunications Union, Telecommunication Standardization Sector of ITU (ITU-T), Series T: Terminal Equipments and Protocols for Telematic Services, "Procedures for Document Facsimile Transmission in the General Switched Telephone Network", ITU-T Recommendation T.30, Jul. 1996, 176 pages.

International Telecommunications Union, The International Telegraph and Telephone Consultative Committee (CCITT), Data Communication Over The Telephone Network, "A 2-Wire Modem for Facsimile Applications with Rates Up to 14 400 bit/s", Recommendation V.17, Feb. 1991, 13 pages.

International Telecommunications Union, Telecommunication Standardization Sector of ITU (ITU-T), Series T: Terminal Equipments and Protocols for Telematic Services, "Standardization of Group 3 Facsimile Terminals for Document Transmission", ITU-T Recommendation T.4, Jul. 1996, 60 pages.

Services, "Standardization of Group 3 Facsimile Terminals for Document Transmission", ITU-T Recommendation T.4—Amendment 1, Jul. 1997, 10 pages.

International Telecommunications Union, Telecommunication Standardization Sector of ITU (ITU-T), Series T: Terminals for Telematic Services, "Standardization of Group 3 Facsimile Terminals for Document Transmission", ITU-T Recommendation T.4—Amendment 2, Oct. 1997, 14 pages.

International Telecommunications Union, Telecommunication Standardization Sector of ITU (ITU-T), Series T: Terminals for Telematic

Services, "Procedures for Document Facsimile Transmission in the General Switched Telephone Network", ITU-T Recommendation T.30—Amendment 1, Jul. 1997, 110 pages.

International Telecommunications Union, Telecommunication Standardization Sector of ITU (ITU-T), Series T: Terminals for Telematic Services, "Procedures for Document Facsimile Transmission in the General Switched Telephone Network", ITU-T Recommendation T.30—Amendment 2, Oct. 1997, 18 pages.

* cited by examiner

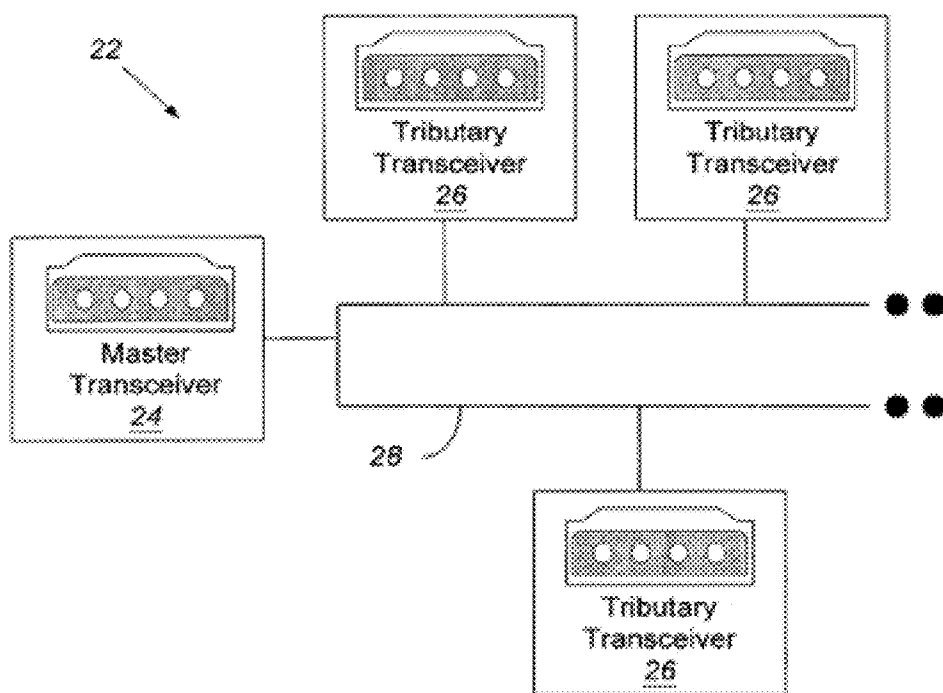

FIG. 1
Prior Art

Explore Litigation Insights

Docket Alarm provides insights to develop a more informed litigation strategy and the peace of mind of knowing you're on top of things.

Real-Time Litigation Alerts



Keep your litigation team up-to-date with **real-time alerts** and advanced team management tools built for the enterprise, all while greatly reducing PACER spend.

Our comprehensive service means we can handle Federal, State, and Administrative courts across the country.

Advanced Docket Research



With over 230 million records, Docket Alarm's cloud-native docket research platform finds what other services can't. Coverage includes Federal, State, plus PTAB, TTAB, ITC and NLRB decisions, all in one place.

Identify arguments that have been successful in the past with full text, pinpoint searching. Link to case law cited within any court document via Fastcase.

Analytics At Your Fingertips



Learn what happened the last time a particular judge, opposing counsel or company faced cases similar to yours.

Advanced out-of-the-box PTAB and TTAB analytics are always at your fingertips.

API

Docket Alarm offers a powerful API (application programming interface) to developers that want to integrate case filings into their apps.

LAW FIRMS

Build custom dashboards for your attorneys and clients with live data direct from the court.

Automate many repetitive legal tasks like conflict checks, document management, and marketing.

FINANCIAL INSTITUTIONS

Litigation and bankruptcy checks for companies and debtors.

E-DISCOVERY AND LEGAL VENDORS

Sync your system to PACER to automate legal marketing.