



US005982124A

United States Patent [19]
Wang

[11] **Patent Number:** 5,982,124
[45] **Date of Patent:** Nov. 9, 1999

[54] **METHOD AND APPARATUS FOR ADAPTIVE CONTROL OF A VEHICLE POWER WINDOW**

[75] **Inventor:** John Y. Wang, Wixom, Mich.

[73] **Assignee:** TRW Inc., Lyndhurst, Ohio

[21] **Appl. No.:** 08/886,372

[22] **Filed:** Jul. 1, 1997

Related U.S. Application Data

[63] Continuation of application No. 08/521,540, Aug. 30, 1995, abandoned.

[51] **Int. Cl.⁶** G05B 5/00

[52] **U.S. Cl.** 318/466; 318/286; 318/446; 318/461; 49/140

[58] **Field of Search** 318/445-487, 318/280-300; 49/139-140

[56] **References Cited**

U.S. PATENT DOCUMENTS

3,891,909	6/1975	Newson	318/469
4,096,579	6/1978	Black et al.	318/603
4,394,605	7/1983	Terazawa	318/280
4,468,596	8/1984	Kinzl et al.	318/287
4,628,234	12/1986	Mizuta et al.	318/267
4,641,067	2/1987	Iizawa et al.	318/287
4,686,598	8/1987	Herr	318/286
4,746,845	5/1988	Mizuta et al.	318/286
4,831,315	5/1989	Hammond et al.	318/572
4,900,994	2/1990	Mizuta	318/283

5,069,000	12/1991	Zuckerman	49/28
5,162,711	11/1992	Heckler	318/264
5,278,480	1/1994	Murray	318/626
5,410,226	4/1995	Sekiguchi et al.	318/266
5,416,395	5/1995	Hiramatsu et al.	318/600
5,436,539	7/1995	Wrenbeck et al.	318/265
5,497,326	3/1996	Berland et al.	318/468

Primary Examiner—David Martin
Attorney, Agent, or Firm—Tarolli, Sundheim, Covell, Tummino & Szabo

[57] **ABSTRACT**

An adaptive vehicle power window control apparatus (20) includes an electric motor (28) for moving a member (34) between a first position and a second position. The space between the first position and the second position is divided into a plurality of trap zones and each zone has an associated sensitivity value. A controller 24 determines (40) a value functionally related to the present motor speed and determines (44) a value functionally related to a reference motor speed. The sensitivity value is adjusted as a function of the two determined values. A window zone determining function (62) determines which of the plurality zones the member (34) is located. The value functionally related to present motor speed is adjusted (52) as a function of the sensitivity value for the zone that the member is located. A comparing function (48) compares the adjusted value with the value functionally related to reference motor speed. The motor direction and movement is controlled as a function of the comparison. Zone locations are adjustable with a calibration procedure.

22 Claims, 7 Drawing Sheets

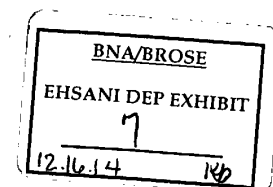
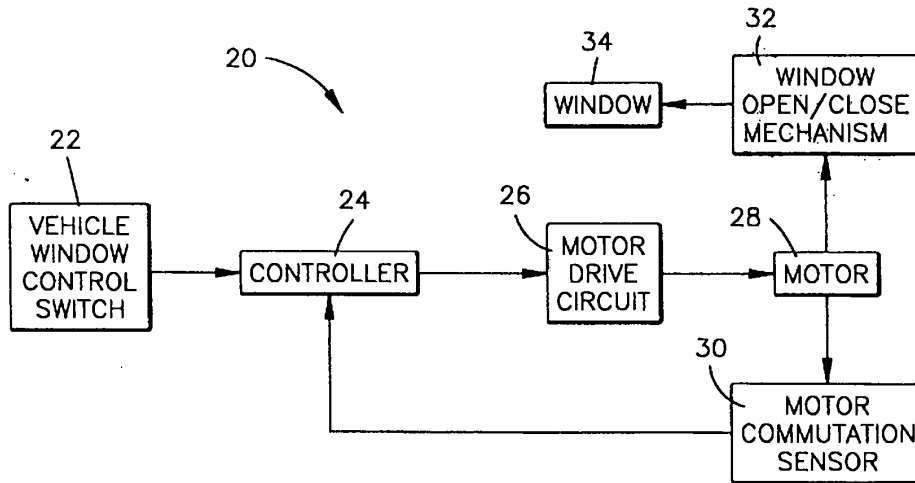

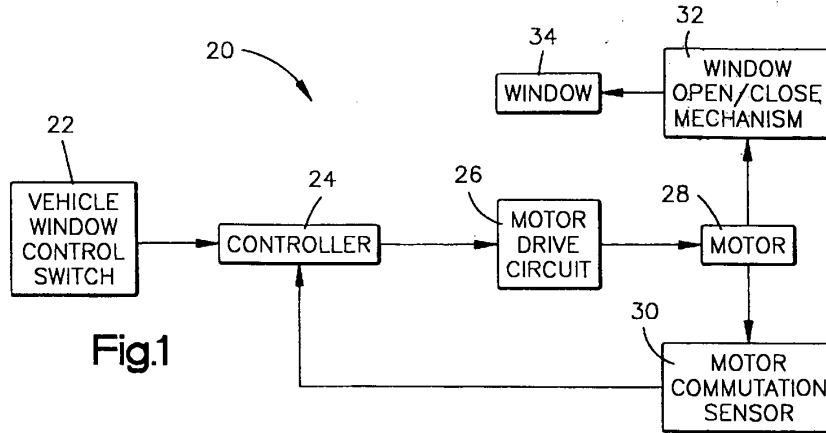

Fig.1

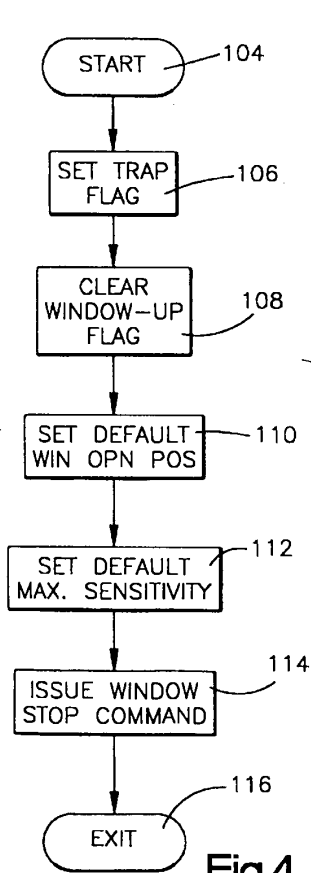

Fig.4

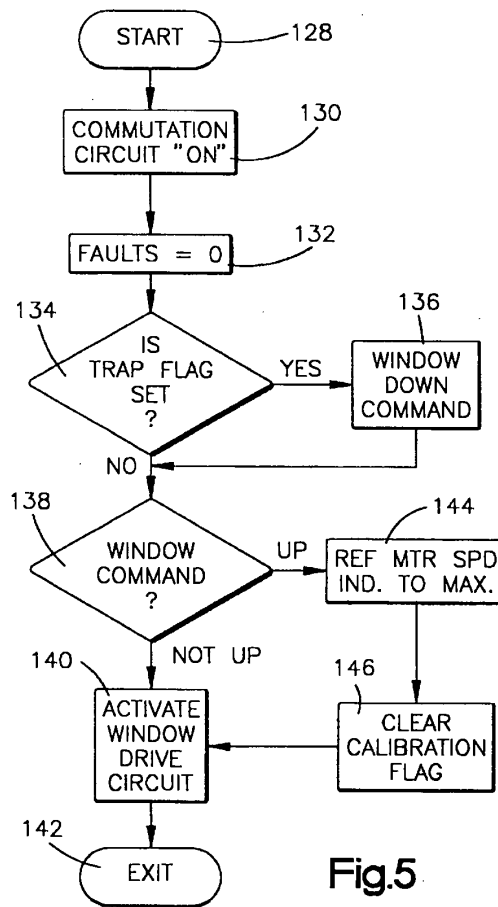
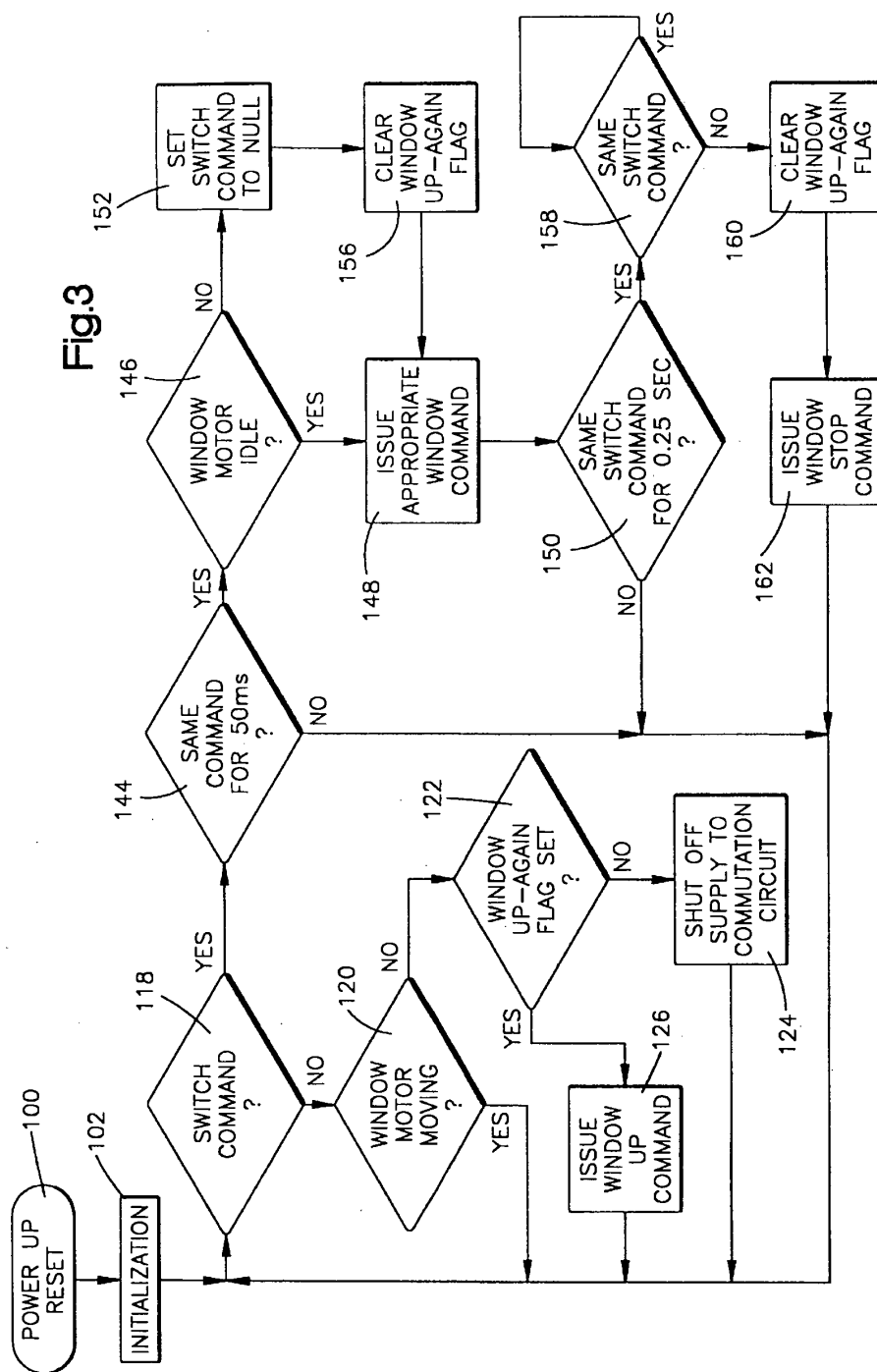

Fig.5

Fig.3



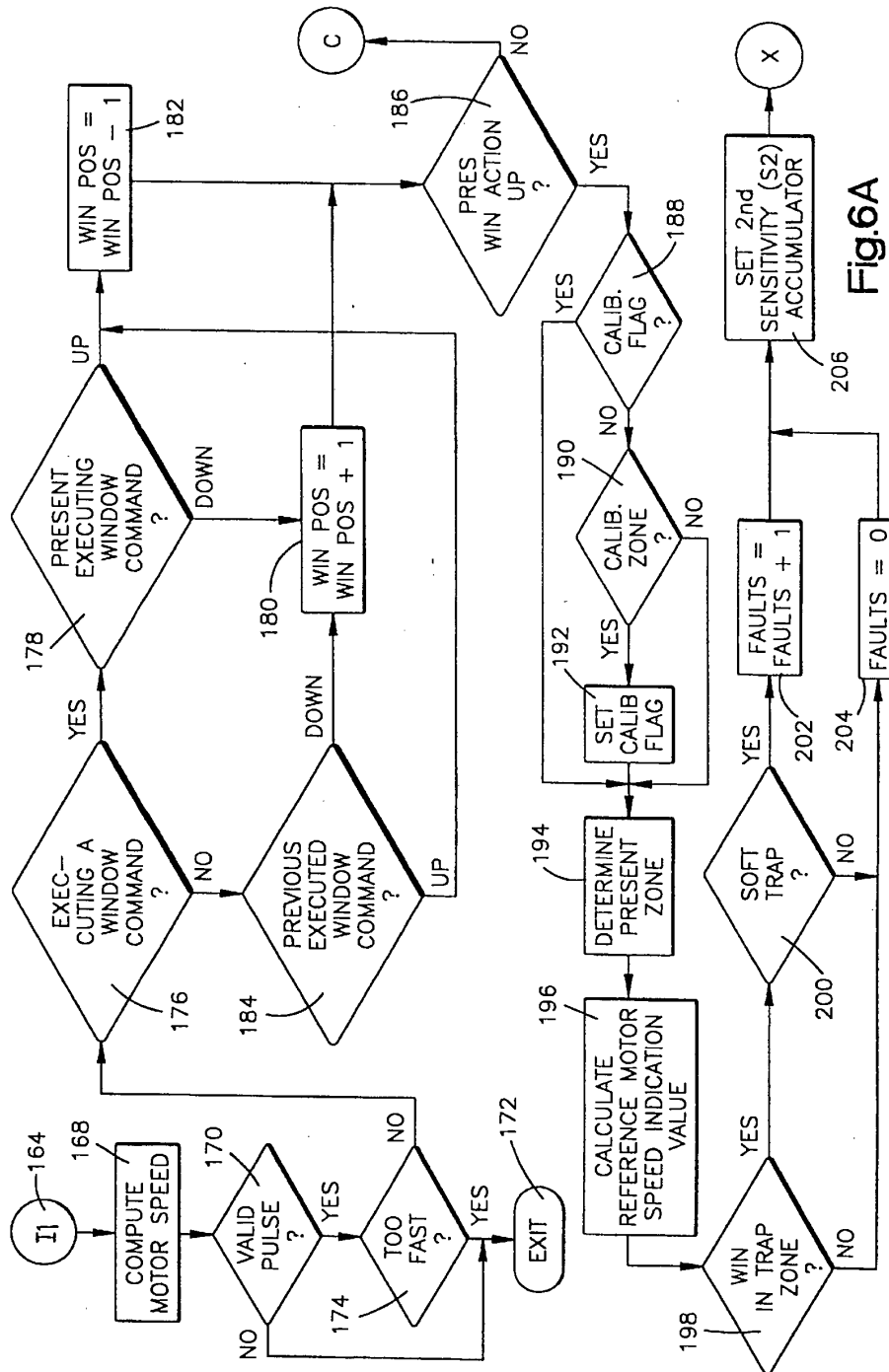

Fig 6A

Explore Litigation Insights

Docket Alarm provides insights to develop a more informed litigation strategy and the peace of mind of knowing you're on top of things.

Real-Time Litigation Alerts



Keep your litigation team up-to-date with **real-time alerts** and advanced team management tools built for the enterprise, all while greatly reducing PACER spend.

Our comprehensive service means we can handle Federal, State, and Administrative courts across the country.

Advanced Docket Research



With over 230 million records, Docket Alarm's cloud-native docket research platform finds what other services can't. Coverage includes Federal, State, plus PTAB, TTAB, ITC and NLRB decisions, all in one place.

Identify arguments that have been successful in the past with full text, pinpoint searching. Link to case law cited within any court document via Fastcase.

Analytics At Your Fingertips



Learn what happened the last time a particular judge, opposing counsel or company faced cases similar to yours.

Advanced out-of-the-box PTAB and TTAB analytics are always at your fingertips.

API

Docket Alarm offers a powerful API (application programming interface) to developers that want to integrate case filings into their apps.

LAW FIRMS

Build custom dashboards for your attorneys and clients with live data direct from the court.

Automate many repetitive legal tasks like conflict checks, document management, and marketing.

FINANCIAL INSTITUTIONS

Litigation and bankruptcy checks for companies and debtors.

E-DISCOVERY AND LEGAL VENDORS

Sync your system to PACER to automate legal marketing.