

# Model RFT9739 Rack-Mount Transmitter

## Instruction Manual

Version 3 Transmitters

February 2000

**Micro Motion**

---

**FISHER-ROSEMOUNT™ Managing The Process Better.™**



# Model RFT9739

## Rack-Mount Transmitter

### Instruction Manual

Version 3 Transmitters

For technical assistance, phone the Micro Motion Customer Service Department:

- In the U.S.A., phone 1-800-522-6277, 24 hours
- Outside the U.S.A., phone 303-530-8400, 24 hours
- In Europe, phone +31 (0) 318 549 443
- In Asia, phone 65-770-8155

**Copyright © 2000, Micro Motion, Inc. All rights reserved.**

Micro Motion, ELITE, and ProLink are registered trademarks of Micro Motion, Inc., Boulder, Colorado. Rosemount and SMART FAMILY are registered trademarks of Rosemount, Inc., Eden Prairie, Minnesota. Fisher-Rosemount is a trademark of Fisher-Rosemount, Clayton, Missouri. HART is a registered trademark of the HART Communication Foundation, Austin, Texas. Modbus is a registered trademark of Modicon, Inc., North Andover, Massachusetts. Tefzel is a registered trademark of E.I. Du Pont de Nemours Co., Inc., Wilmington, Delaware.



# Contents

<b>1</b>	<b>Before You Begin</b>	<b>1</b>
1.1	About this manual	1
1.2	About the transmitter	1
<b>2</b>	<b>Getting Started</b>	<b>3</b>
2.1	Hazardous area installations	3
	Hazardous area installations in Europe	4
2.2	Configuration, calibration, and characterization	4
2.3	Switch settings	5
	Security modes	6
	Security mode 8	7
	Communication settings	9
	Milliamp output scaling	9
<b>3</b>	<b>Transmitter Mounting</b>	<b>11</b>
3.1	General guidelines	11
3.2	Connectors	15
<b>4</b>	<b>Power-Supply and Sensor Wiring</b>	<b>17</b>
4.1	General guidelines	17
4.2	Power supply and grounding	17
	Power-supply options	17
	Power-supply wiring	18
	Grounding	19
	Fuses	21
4.3	Changing power-supply voltage	21
4.4	Sensor wiring	22
	Cable connections to sensor and transmitter	22

<b>5</b>	<b>Output Wiring</b>	<b>25</b>
5.1	General guidelines	25
5.2	Maximum wire length	25
5.3	Primary and secondary mA outputs	27
	Connections for HART® communication devices	29
5.4	Frequency outputs	30
	Frequency/pulse output	30
	Default configuration	31
	Configuration for increased current	31
	Configuration for constant current	32
	Configuration for open collector mode	33
	Dual-channel frequency output	36
	Setting voltage level for VDE output requirements	37
	Optocoupler output	39
5.5	Control output	40
	Control output in open collector mode	41
5.6	Peripheral device wiring	44
5.7	Pressure transmitter wiring	51
5.8	Remote-zero switch	54
5.9	RS-485 multidrop network	55
5.10	Bell 202 multidrop network	56
5.11	Security wiring	58
<b>6</b>	<b>Startup</b>	<b>59</b>
6.1	Initialization	59
6.2	Using the display	60
	Process variables mode	60
	Communication configuration mode	61
6.3	Custody transfer event registers	64
6.4	Flowmeter zeroing	65
	Zeroing procedure	65
	Diagnosing zero failure	66
	Additional information about flowmeter zeroing	66
6.5	Totalizer control	67
6.6	Process measurement	68

<b>7</b>	<b>Troubleshooting</b>	<b>69</b>
7.1	General guidelines	69
7.2	Transmitter diagnostic tools	69
	Fault outputs	69
	Diagnostic messages	70
7.3	Interrogation with a HART® device	70
7.4	Troubleshooting using the transmitter display	73
	Not configured	73
	Transmitter failure messages	73
	Overrange and sensor error messages	74
	Slug flow	74
	Output saturated messages	74
	Informational messages	76
7.5	Power supply	77
7.6	Wiring	78
7.7	Master reset	79
7.8	Additional information about troubleshooting	81
7.9	Customer service	81

## Appendixes

Appendix A	RFT9739 Specifications	83
Appendix B	Ordering Information	91
Appendix C	Theory of Operation	93
Appendix D	HART® Communicator Menu Trees	97
Appendix E	Transmitter Version Identification	101
Appendix F	Replacing Older Transmitters	103
Appendix G	Return Policy	111

<b>Index</b>	<b>113</b>
--------------	------------

## Tables

Table 2-1	Security modes . . . . .	6
Table 4-1	Selecting the proper grounding scheme . . . . .	19
Table 4-2	Terminal designations . . . . .	23
Table 5-1	Output wiring terminal designations . . . . .	26
Table 5-2	Peripheral wiring diagrams . . . . .	44
Table 5-3	Sensors affected by pressure . . . . .	51
Table 6-1	Display screens. . . . .	60
Table 6-2	Parameters that affect event registers . . . . .	64
Table 6-1	Effect of security modes on flowmeter zeroing . . . . .	66
Table 6-2	Effect of security modes on totalizer control . . . . .	68
Table 7-1	Fault output levels . . . . .	69
Table 7-2	Using transmitter failure messages. . . . .	73
Table 7-3	Using overrange and sensor error messages . . . . .	75
Table 7-4	Using slug flow and output saturated messages . . . . .	75
Table 7-5	Using informational messages . . . . .	77
Table 7-6	Nominal resistance ranges for flowmeter circuits. . . . .	78
Table 7-7	Default values after a master reset . . . . .	80

## Tables in appendixes

Table F-1	Resistance values for determining RTD type . . . . .	104
Table F-2	RE-01 to RFT9739 terminal conversions . . . . .	106
Table F-3	RFT9712 to RFT9739 terminal conversions . . . . .	107
Table F-4	RFT9729 to RFT9739 terminal conversions . . . . .	108



## Figures

Figure 1-1	RFT9739 exploded view . . . . .	2
Figure 2-1	Hazardous area approvals tag . . . . .	3
Figure 2-2	Switches . . . . .	5
Figure 3-1	RFT9739 dimensions . . . . .	12
Figure 3-2	Rack-mount connector locations . . . . .	13
Figure 3-3	Space requirements for proper ventilation . . . . .	14
Figure 3-4	Types of connectors . . . . .	15
Figure 4-1	Power-supply wiring terminals . . . . .	18
Figure 4-2a	Grounding detail - typical . . . . .	19
Figure 4-2b	Grounding detail - hazardous-area sensor installations . . . . .	20
Figure 4-2c	Grounding detail - high-integrity I.S. installations . . . . .	20
Figure 4-3	Fuses and power-select switch. . . . .	21
Figure 4-4	Wiring to ELITE sensors . . . . .	23
Figure 4-5	Wiring to F-Series, Model D and DL sensors . . . . .	23
Figure 4-6	Wiring to Model DT sensors . . . . .	24
Figure 5-1	Output terminals . . . . .	26
Figure 5-2	4-20 mA output performance . . . . .	27
Figure 5-3	Primary and secondary mA output wiring . . . . .	28
Figure 5-4	HART <sup>®</sup> Communicator, ProLink <sup>®</sup> PC-Interface, and AMS modem connections . . . . .	29
Figure 5-5	Frequency/pulse output wiring . . . . .	31
Figure 5-6	Frequency/pulse output wiring for increased current . . . . .	31
Figure 5-7	Frequency/pulse output wiring for constant current . . . . .	32
Figure 5-8	Frequency/pulse output wiring for open collector mode . . . . .	34
Figure 5-9	RFT9739 back panel . . . . .	34
Figure 5-10	Resistor R5 on inside of back panel . . . . .	35
Figure 5-11	Dual-channel frequency output wiring . . . . .	36
Figure 5-12	RFT9739 back panel and power board . . . . .	37
Figure 5-13	Jumper J10 on power board . . . . .	38
Figure 5-14	Jumper JP1 on inside of back panel. . . . .	38
Figure 5-15	Optocoupler output wiring. . . . .	39
Figure 5-16	Control output wiring. . . . .	40
Figure 5-17	Control output wiring for open collector mode . . . . .	42
Figure 5-18	RFT9739 back panel . . . . .	42
Figure 5-19	Location of resistor R4 on inside of back panel . . . . .	43
Figure 5-20	Wiring to DMS. . . . .	44
Figure 5-21a	Wiring to DRT with LED . . . . .	45
Figure 5-21b	Wiring to DRT with LCD . . . . .	45
Figure 5-22a	Wiring to FMS-3 with LED . . . . .	46
Figure 5-22b	Wiring to FMS-3 with LCD . . . . .	46
Figure 5-23	Wiring to NFC . . . . .	47
Figure 5-24a	Wiring to AC-powered NOC . . . . .	48
Figure 5-24b	Wiring to DC-powered NOC . . . . .	48
Figure 5-25a	Wiring to Model 3300 with screw-type or solder-tail terminals . . . . .	49
Figure 5-25b	Wiring to Model 3300 with I/O cable. . . . .	49
Figure 5-26	Wiring to Model 3350 . . . . .	50

Contents continued

Figure 5-27a	Wiring to pressure transmitter - analog output	52
Figure 5-27b	Wiring to pressure transmitter - external power, analog input	53
Figure 5-27c	Wiring to pressure transmitter - digital communications	53
Figure 5-28	Wiring to remote-zero switch	54
Figure 5-29	RS-485 wiring	56
Figure 5-30	Typical HART® network wiring	57
Figure 5-31	Inhibit-switch wiring	58
Figure 7-1	HART® Communicator, ProLink® PC-Interface, and AMS modem connections	71

Figures in appendixes

Figure C-1	Coriolis mass flow sensor	93
Figure D-1	On-line menu	97
Figure E-1	RFT9739 back panels	101
Figure F-1	RFT9739 terminals	105
Figure F-2	RE-01 Remote Electronics Unit terminals	106
Figure F-3	RFT9712 Remote Flow Transmitter terminals	107
Figure F-4	RFT9729 Remote Flow Transmitter terminals	108

## 1

# Before You Begin

## 1.1 About this manual

This instruction manual explains how to:

- Install the Micro Motion® Model RFT9739 rack-mount transmitter for use with Micro Motion Coriolis flow sensors, including instructions for:
  - Power-supply and sensor wiring
  - Output wiring
- Initialize the transmitter
- Diagnose and troubleshoot problems with the transmitter

For more information about the Micro Motion sensors, see the appropriate sensor instruction manual.

Instructions in this manual pertain to Version 3 transmitters. Do not use this manual for transmitters shipped before January 1996. To identify the transmitter version, see **Appendix E**, page 101.

## 1.2 About the transmitter

Micro Motion rack-mount transmitters have enhanced EMI immunity that complies with EMC directive 89/336/EEC and low-voltage directive 73/23/EEC, when properly installed in accordance with the guidelines and instructions in this manual.

The Model RFT9739 transmitter is a microprocessor-based transmitter for fluid process measurement. The transmitter works with Micro Motion sensors to measure mass or volume flow, density, and temperature.

The rack-mount RFT9739 is for control-room mounting. The housing is a 1/3 rack cassette for 19-inch enclosure-dense packaging. Components of the transmitter are shown in **Figure 1-1**, page 2.

The RFT9739 front panel has a two-line, 16-character, alphanumeric liquid crystal display (LCD). Scroll and Reset buttons enable the user to perform the following operations. Use of the display is described in **Section 6.2**, page 60.

- View the flow rate, density, temperature, mass and volume totals and inventory levels, and status messages
- Set the transmitter's flow totalizers
- Reset communication parameters
- Zero the flowmeter

Figure 1-1. RFT9739 exploded view

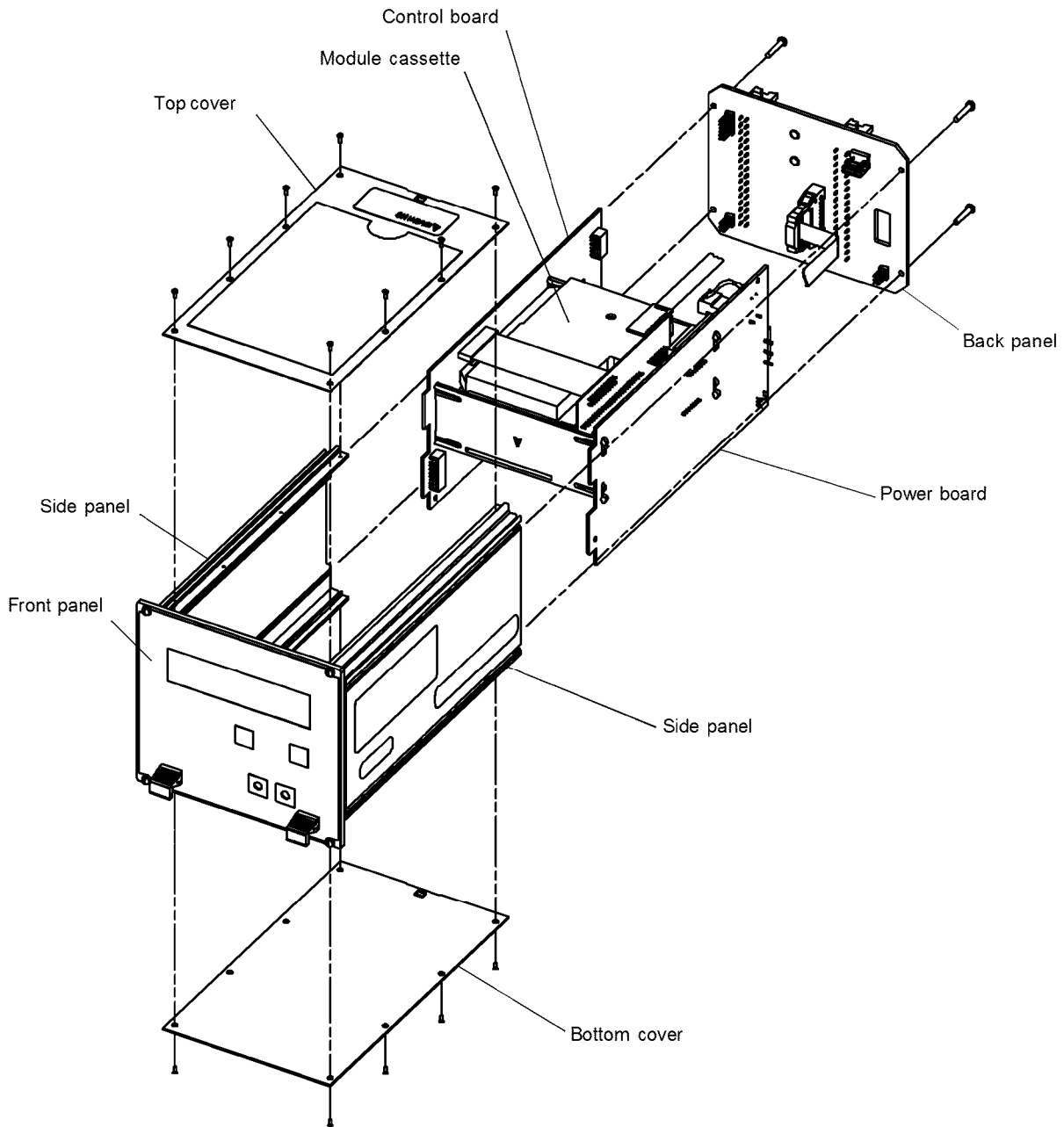

## 2.1 Hazardous area installations

**⚠ WARNING**

**If the sensor is installed in a hazardous area, failure to comply with requirements for intrinsic safety could result in an explosion.**

- Install the transmitter in a non-hazardous area.
- For intrinsically safe sensor installations, use this document with Micro Motion UL or CSA installation instructions.
- For hazardous area installations in Europe, refer to standard EN 60079-14 if national standards do not apply.

- Read the approvals tag before installing the RFT9739. The approvals tag is attached to the side of the transmitter. See **Figure 2-1**.
- For a complete list of UL, CSA, and European approvals, see page 88.
- For an intrinsically safe installation of the sensor, use this manual with the appropriate Micro Motion intrinsically safe installation instructions:
  - UL-D-IS Installation Instructions
  - CSA-D-IS Installation Instructions
- In Europe, refer to standard EN60079-14 if national standards do not apply. To comply with CENELEC standards, see page 4.

The RFT9739 rack-mount transmitter is classified as a Class A product. When used in a residential area or in an adjacent area thereto, radio interference may be caused by radios, television receivers, and like devices.

**Figure 2-1.**  
Hazardous area approvals tag

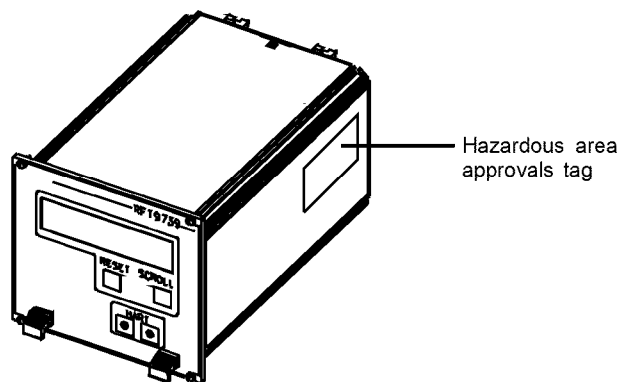

### Hazardous area installations in Europe

To comply with CENELEC standards for hazardous area installations in Europe, adhere to the following CENELEC conditions for safe use.

#### Location

The RFT9739 must be installed outside the hazardous area. The transmitter installation must meet (at least) IP20 safety requirements, per IEC 529.

#### Potential equalization

To achieve potential equalization, the RFT9739 ground conductor should be connected to the appropriate ground terminals within the hazardous area, using a potential equalizing line.

#### Output wiring

Nonintrinsically-safe connections between the RFT9739 and other devices may be made **only** to devices that maintain a voltage less than or equal to 250 V.

## 2.2 Configuration, calibration, and characterization

The following information explains the differences among configuration, calibration, and characterization. Certain parameters might require configuration even when calibration is not necessary.

**Configuration parameters** include items such as transmitter tag, measurement units, flow direction, damping values, slug flow parameters, and span values for the milliamp and frequency outputs. If requested at time of order, the transmitter is configured at the factory according to customer specifications.

**Calibration** accounts for an individual sensor's sensitivity to flow, density, and temperature. Field calibration is optional.

**Characterization** is the process of entering calibration factors for flow, density, and temperature directly into transmitter memory. Calibration factors can be found on the sensor serial number tag and on the certificate that is shipped with the sensor.

For configuration, calibration, or characterization procedures, see one of the following communications manuals:

- Using the HART Communicator with Micro Motion Transmitters
- Using ProLink Software with Micro Motion Transmitters
- Using Modbus Protocol with Micro Motion Transmitters

You can also use Fisher-Rosemount<sup>®</sup> Asset Management Solutions (AMS) software for configuration, calibration, and characterization. For more information, see the AMS on-line help.

A basic software tree for the HART Communicator is shown in **Appendix D**, page 97.

# Getting Started continued

## 2.3 Switch settings

Switches 1 through 10, located inside the transmitter on the control board, control the following transmitter functions (see **Figure 1-1**, page 2, for the location of the control board):

- Communications settings, including baud rate, stop bits and parity, data bits, communication protocol, and physical layer
- mA outputs
- Zeroing method
- Write-protection of transmitter configuration

Switches are shown in **Figure 2-2**, and described in the following sections. To access switches, remove the bottom cover of the transmitter housing. Normally, switch settings do not require adjustment.

**Figure 2-2.**  
Switches

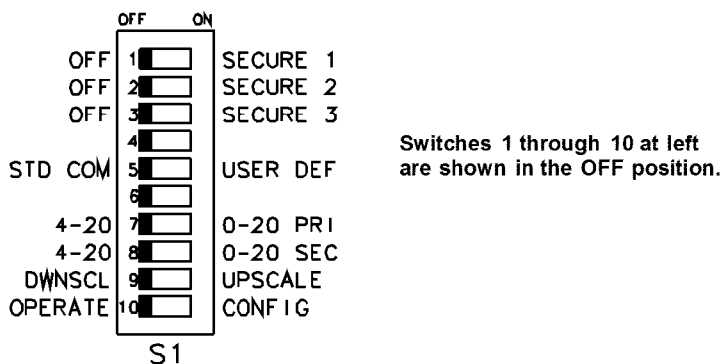

**Security modes**

Switches 1, 2, and 3 are security switches, which enable the user to disable flowmeter zeroing, disable resetting of totalizers, and write-protect all configuration and calibration parameters.

Switch settings enable any of eight possible security modes. Different modes determine which functions are disabled and whether configuration and calibration parameters are write-protected. The following functions can be disabled:

- Flowmeter zeroing using digital communications
- Flowmeter zeroing using the Scroll and Reset buttons
- Totalizer control, with flow, using digital communications
- Totalizer control, with flow, using the Scroll and Reset buttons
- Totalizer control, with zero flow, using digital communications
- Totalizer control, with zero flow, using the Scroll and Reset buttons

**Table 2-1** lists the parameters that are write-protected and functions that are disabled for each security mode. Security modes 1 through 7 are entered immediately when switches are set.

For information about security mode 8, see pages 7 through 8.

**Table 2-1. Security modes**

Switch settings		Mode 1	Mode 2	Mode 3	Mode 4	Mode 5	Mode 6	Mode 7	Mode 8*
Switch 1		OFF	OFF	OFF	OFF	ON	ON	ON	ON
Switch 2		OFF	OFF	ON	ON	OFF	OFF	ON	ON
Switch 3		OFF	ON	OFF	ON	OFF	ON	OFF	ON

Function/parameter	Performed with	Mode 1	Mode 2	Mode 3	Mode 4	Mode 5	Mode 6	Mode 7	Mode 8
Flowmeter zeroing	Zero button or Reset button		Disabled	Disabled	Disabled	Disabled	Disabled	Disabled	Disabled
	HART or Modbus			Disabled	Disabled	Disabled			Disabled
Totalizer control, no flow	Scroll and Reset buttons		Disabled		Disabled	Disabled		Disabled	
	HART or Modbus			Disabled		Disabled	Disabled		
Totalizer control, with flow	Scroll and Reset buttons		Disabled	Disabled	Disabled	Disabled	Disabled	Disabled	Disabled
	HART or Modbus			Disabled	Disabled	Disabled	Disabled	Disabled	Disabled
Configuration and calibration parameters				Write-protected	Write-protected	Write-protected	Write-protected	Write-protected	Write-protected

\*Changing the settings of switches 1, 2, and 3 does not immediately implement security mode 8. For more information about security mode 8, see pages 7 through 8.



## Security mode 8

When transmitter security is set for mode 8, the transmitter meets security requirements for custody transfer described in National Institute of Standards and Technology (NIST) Handbook 44.

Once the transmitter is configured for security mode 8, the security mode cannot be changed unless a master reset is performed. A master reset causes all configuration parameters to return to their default values, and **requires complete characterization and reconfiguration of the transmitter.**

If the user attempts to enter a new security mode or change the transmitter configuration after entering security mode 8:

- Internal totalizers stop counting
- The frequency/pulse output goes to 0 Hz
- mA outputs go to 4 mA
- The display reads "SECURITY BREACH; SENSOR OK"
- Custody transfer event registers record each change made to defined configuration and calibration parameters. (For a list of these parameters, see **Table 6-2**, page 64.)

The security breach continues, and totalizers and outputs remain inactive, until the transmitter is reconfigured for security mode 8, or until a master reset has been performed. Custody transfer event registers are not affected by a master reset.

- For information about event registers, see **Section 6.3**, page 64.
- To perform a master reset, see **Section 7.7**, page 79.

Milliamp output trim, milliamp output test, and frequency/pulse output test procedures cannot be performed after security mode 8 is entered. **Before entering security mode 8**, perform milliamp trim and/or test procedures, if necessary, as described in any of the following manuals or in AMS on-line help:

- Using the HART Communicator with Micro Motion Transmitters
- Using ProLink Software with Micro Motion Transmitters
- Using Modbus Protocol with Micro Motion Transmitters

### To enter security mode 8:

1. Note the position of switch 5.
2. Set switches 1, 2, 3, and 10 to the ON position.
3. Set switches 4, 5, and 6 to the OFF position.
4. Locate the Reset button on the transmitter front panel.
5. Press and hold the Reset button for ten seconds.
6. Reset switch 5 to the desired position (as noted in Step 1).
7. Reset switch 10 to the OFF (OPERATE) position.
8. To verify the transmitter is in security mode 8, use the Scroll button to scroll through the display screens. The transmitter is in security mode 8 if the CONFIG REG and CALIBRATE REG screens appear.
9. Leave switches 1, 2 and 3 in the ON position to maintain security mode 8.

**To verify the transmitter is in security mode 8:**

Use the Scroll button to scroll through process variable screens to event register screens. If event register screens appear, the transmitter is in security mode 8. For more information about using the Scroll button and transmitter display, see **Section 6.2**, page 60.

**To make changes to configuration or calibration parameters once security mode 8 is entered:**

1. Set switches 1, 2, and 3 to the OFF position.
2. Make changes through digital communication or with the Scroll and Reset buttons (see "Communication configuration mode", page 61). Custody transfer event registers record changes made to defined configuration and calibration parameters. For more information about digital communications, see the following instruction manuals or use AMS on-line help:
  - Using the HART Communicator with Micro Motion Transmitters
  - Using ProLink Software with Micro Motion Transmitters
  - Using Modbus Protocol with Micro Motion Transmitters
3. Set switches 1, 2, and 3 to the ON position.

**To reenter security mode 8:**

If security mode 8 has been established previously, and the security mode has been temporarily changed, it is not necessary to use the Reset button to reenter security mode 8. In such a case, resetting switches 1, 2, and 3 to the ON position will reenter security mode 8 immediately.

If a master reset has been performed, it is necessary to use the Reset button method to reenter security mode 8. See the procedure, above.

**To change to a security mode other than mode 8:**

1. Perform a master reset (see **Section 7.7**, page 79, for master reset procedure).
2. Perform characterization and re-configuration procedures as described in any of the following instruction manuals or AMS on-line help:
  - Using the HART Communicator with Micro Motion Transmitters
  - Using ProLink Software with Micro Motion Transmitters
  - Using Modbus Protocol with Micro Motion Transmitters
3. Set switches 1, 2, and 3 to the desired positions. See **Table 2-1**, page 6.

**Communication settings**

Switch 5 enables the user to choose the standard communication configuration or user-defined parameters. With switch 10 in the ON (CONFIG) position, switches 1 through 6 can be used for setting user-defined communication parameters.

**Standard communication setting**

To use the standard communication configuration, set switch 5 to the STD COMM position. Setting the switch in this position establishes the following parameters:

- HART protocol on the Bell 202 standard, at 1200 baud, on the primary mA output
- Modbus protocol in RTU mode, at 9600 baud, on the RS-485 output
- 1 stop bit, odd parity

For RFT9739 software versions 3.6 and later, if switch 5 is in the STD COMM position, an error message will appear on the RFT9739 display when an attempt is made to change the communication configuration using the RFT9739 display controls.

**User-defined communication settings**

To establish user-defined settings, set switch 5 to the USER-DEFINED position, then use the buttons on the front panel to set baud rate; stop bits and parity; data bits, protocol, and physical layer.

- When the transmitter is shipped from the factory, the default settings are HART protocol, over RS-485, at 1200 baud, with 1 stop bit and odd parity.
- For more information on using the display, see **Section 6.2**, page 60.

**Milliamp output scaling**

Switches 7, 8, and 9 allow the user to choose 0-20 mA or 4-20 mA scaling for mA outputs, and upscale or downscale fault outputs.

Switch 7 defines the primary mA output scaling. Switch 8 defines the secondary mA output scaling. Either switch may be set in the 0-20 position or the 4-20 position.

- The mA outputs are NAMUR compliant when switches 7 and 8 are in the 4-20 position. See **Section 5.3**, page 27.
- Communication using the HART protocol over the primary mA output requires switch 7 to be set in the 4-20 position.
- If switch 7 is in the 0-20 mA position, communication may be lost if output is less than 2 mA. To re-establish communication, move switch 7 to the 4-20 mA position.

Switch 9 defines the RFT9739 fault outputs. Fault outputs can be set for downscale or upscale levels.

- If switch 9 is set to the DWNSCALE position, mA outputs go to 0 mA if they produce a 0-20 mA current, or to 0-2 mA if they produce a 4-20 mA current; the frequency/pulse output goes to 0 Hz.
- If switch 9 is set to the UPSCALE position, mA outputs go to 22-24 mA; the frequency/pulse output goes to 15-19 kHz.
- For more information, see "Fault outputs", page 69.



# Transmitter Mounting

## 3.1 General guidelines

Follow these guidelines when installing the rack-mount RFT9739 transmitter:

- Locate the transmitter where it is accessible for service and calibration.
- Install the transmitter in a location that is compliant with the area specified on the RFT 9739 approvals tag (see **Figure 2-1**, page 3).
- To comply with CENELEC standards for hazardous area installations in Europe, the RFT9739 must be installed outside the hazardous area. The transmitter installation must meet (at least) IP20 safety requirements, per IEC 529.
- Total length of cable from the sensor to the transmitter must not exceed 1000 feet (300 meters).
- Locate the transmitter where the ambient temperature remains between 32 and 122°F (0 and 50°C).

The rack-mount RFT 9739 meets DIN standard 41494, 19-inch configuration for control-room equipment.

- Transmitter dimensions are shown in **Figure 3-1**, page 12.
- Three transmitters fit into one 19-inch enclosure with a Eurocard 220 mm depth, as indicated in **Figure 3-2**, page 13.
- When installing multiple transmitters in a single rack, 15 watts of forced-air cooling, per transmitter, is required. Minimum spacing is shown in **Figure 3-3**, page 14.

### CAUTION

**Failure to maintain an ambient temperature below maximum temperature rating could result in operational failure and product damage.**

Install transmitter in an area with sufficient air flow to keep the ambient temperature below 122°F (50°C).

The back panel of the transmitter housing has two 32-pin connectors for sensor wiring and output wiring. These connectors meet DIN standard 41612, Model F (male). For more information, see **Section 3.2**, page 15.

Transmitter Mounting continued

Figure 3-1. RFT9739 dimensions

Dimensions in inches  
(mm)

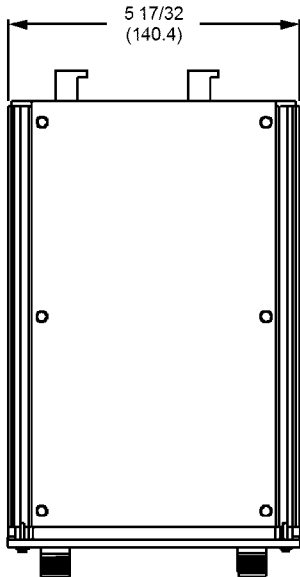

Back panel with  
DIN 41612 male  
Y-shaped screw terminals

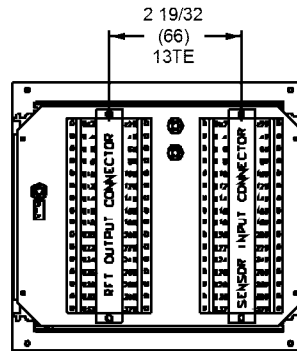

Back panel with  
DIN 41612 male  
fast-on/solder terminals

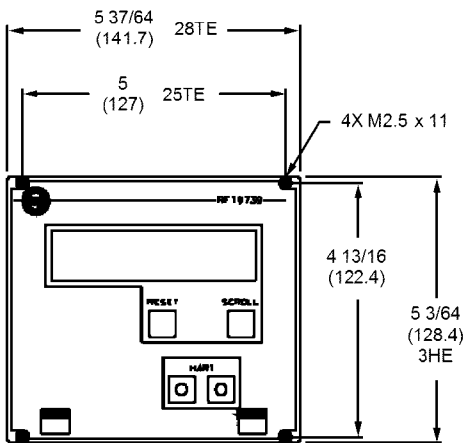
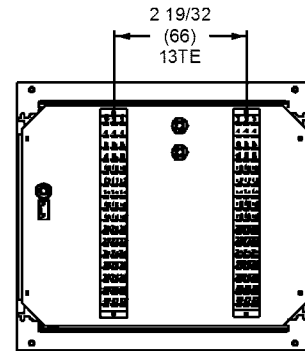

With Y-shaped  
screw terminals

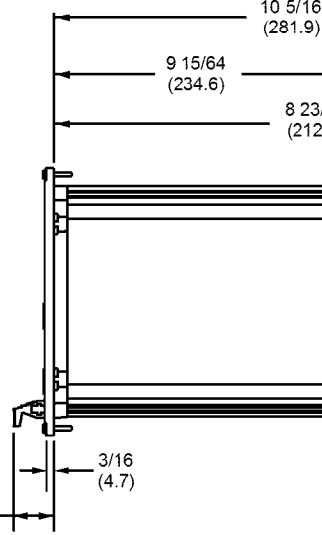

With fast-on/solder  
terminals

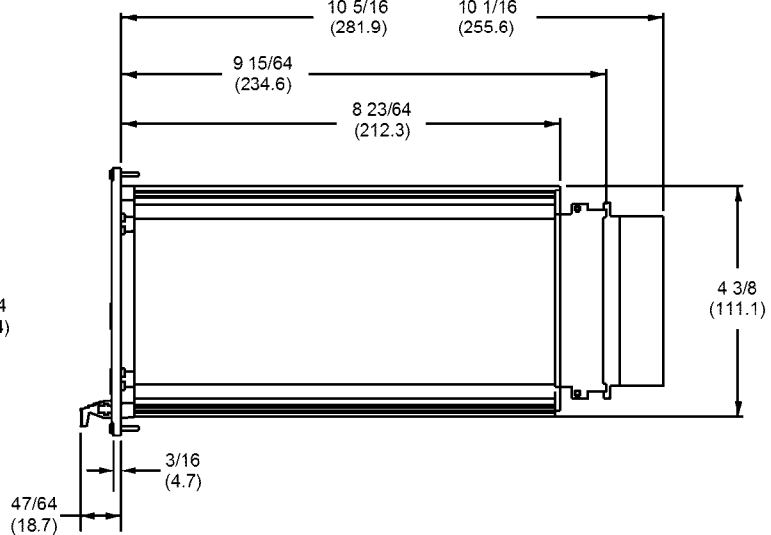

### Transmitter Mounting continued

#### Figure 3-2. Rack-mount connector locations

Dimensions in inches  
(mm)

1 TE  $\cup$  5.08 mm

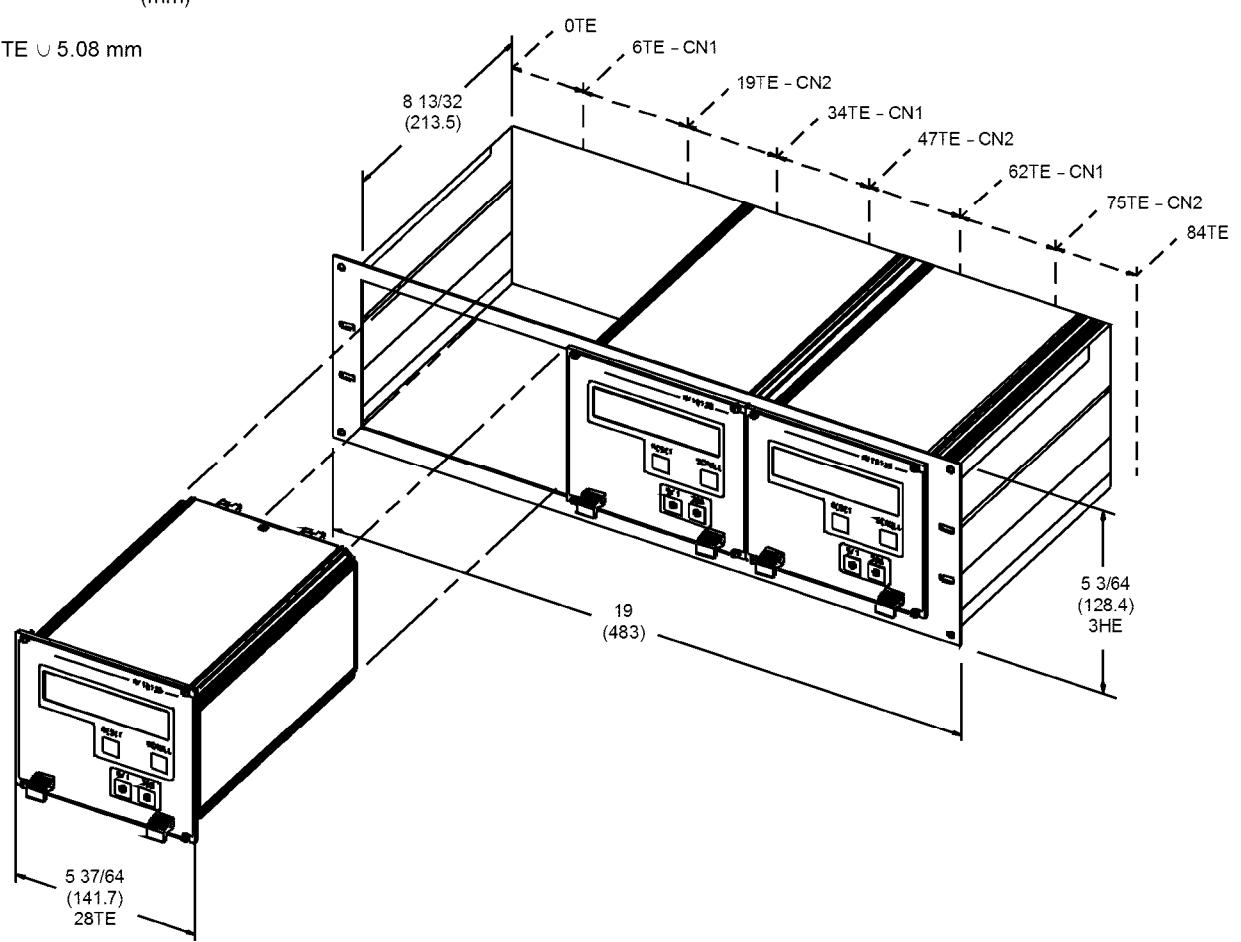

## Transmitter Mounting continued

Figure 3-3. Space requirements for proper ventilation

Dimensions in inches  
(mm)

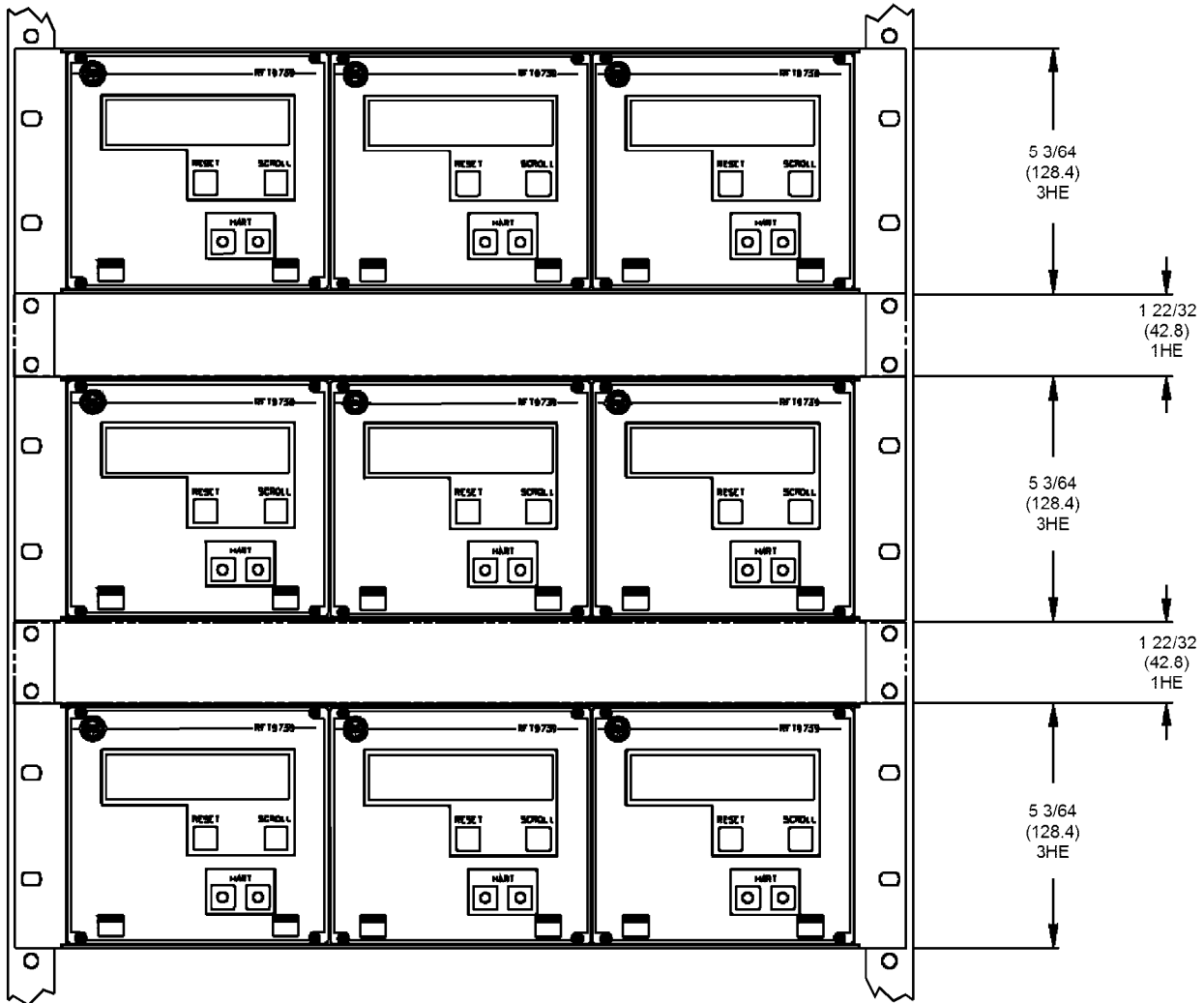

When installing multiple transmitters in a single rack, 15 watts of forced-air cooling, per transmitter, is required. Maintain sufficient air flow to keep the ambient temperature below 122°F (50°C).



### Transmitter Mounting continued

### 3.2 Connectors

The back panel of the transmitter housing has two 32-pin connectors, labeled CN1 and CN2, and a 2-pin connector, labeled CN3. Mating terminal strips, shipped with the transmitter, plug into the connectors. The detachable terminal strips enable wiring to remain connected when the transmitter is removed from the rack.

- AC power-supply wiring connects to CN3
- DC power-supply wiring connects to CN2
- Sensor wiring connects to CN1
- Output wiring connects to CN2

Connectors CN1 and CN2 are available in two types, illustrated in **Figure 3-4**, page 15.

- The standard rectangular configuration accommodates fast-on (wire-pin) or soldered connections.
- The optional Y-shaped connectors have screw terminals, which accommodate wires as large as 14 AWG (2.5 mm $\leq$ ).
- For fast-on/solder connectors, on connector CN1, pin row D is not used; on connector CN2, pin row B is not used.

Connectors CN1 and CN2 meet DIN standard 41612, Model F (male). The positions of connectors CN1 and CN2 in a 19" rack are indicated in **Figure 3-2**, page 13.

- See **Chapter 4**, page 17, for power-supply and sensor wiring instructions.
- See **Chapter 5**, page 25, for output wiring instructions.

Figure 3-4. Types of connectors

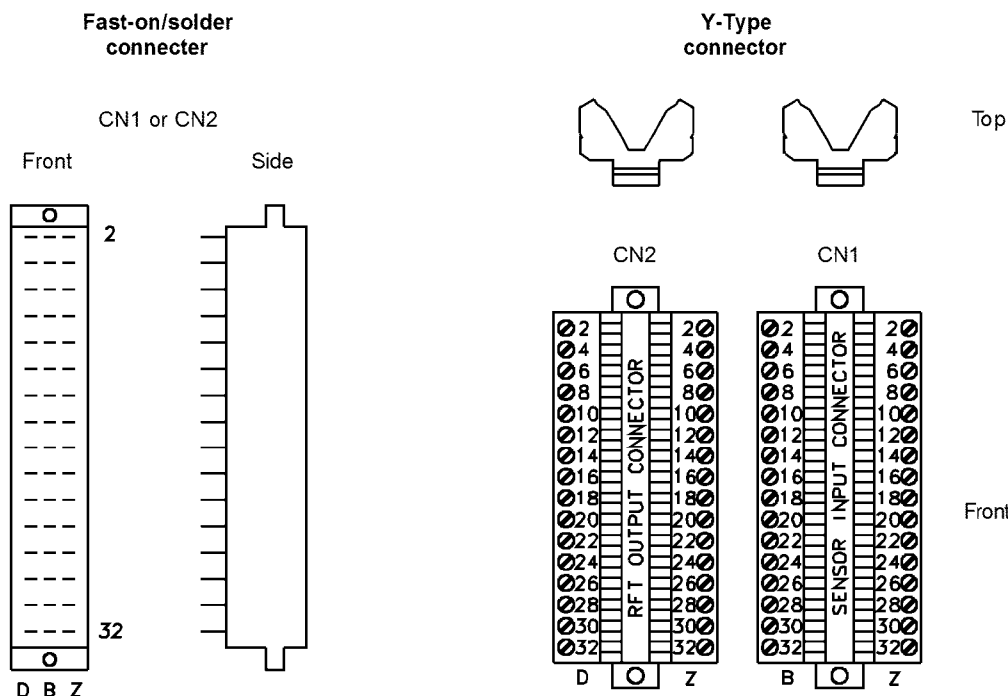



# Power-Supply and Sensor Wiring

## 4.1 General guidelines

**⚠ WARNING**

**Failure to comply with requirements for intrinsic safety if the sensor is installed in a hazardous area could result in an explosion.**

Sensor wiring is intrinsically safe.

- Install the transmitter in a non-hazardous area.
- For intrinsically safe sensor installations, use this document with Micro Motion UL or CSA installation instructions.
- For hazardous area installations in Europe, refer to standard EN 60079-14 if national standards do not apply.

- Terminal blocks may be unplugged from the transmitter back panel for easier installation of wiring.
- Install cable and wiring to meet local code requirements.
- A switch may be installed in the power-supply line. For compliance with low-voltage directive 73/23/EEC, a switch in close proximity to the transmitter is required for AC-powered transmitters.
- Do not install AC power cable or unfiltered DC power cable in the same conduit or cable tray as sensor cable or output wires.

## 4.2 Power supply and grounding

**⚠ CAUTION**

**Incorrect voltage, or installation with power supply on, will cause transmitter damage or failure.**

- Match power-supply voltage with voltage indicated on transmitter back panel. See **Figure 4-1**, page 18.
- Turn off power before installing transmitter.

### Power-supply options

- The transmitter is configured at the factory for a 110/115 or 220/230 VAC power supply. A label in the upper corner on the transmitter's back panel indicates the configured power-supply voltage. See **Figure 4-1**, page 18.
- Any RFT9739 rack-mount transmitter can accept a DC power supply, whether or not the back panel indicates the transmitter has been configured for AC power.
- To change power-supply voltage from the configured voltage, see **Section 4.3**, page 21.

**Power-supply wiring**

Some European applications require installation of AC power-supply wiring to connector CN2, terminals D2 (AC+), D6 (AC-), and Z2 (GND). **In Europe, before making AC power-supply wiring connections at CN2, contact the Micro Motion Customer Service Department. In Europe, phone +31 (0) 318 549 443.**

To install power-supply wiring, refer to **Figure 4-1** and follow these steps:

1. Match power-supply voltage to voltage indicated on the label in the upper corner of the transmitter back panel.
2. Connect AC power-supply wiring at connector CN3 and the ground lug directly above connector CN3; or connect DC power-supply wiring at connector CN2, to terminals Z32 (DC+) and D32 (DC-).
3. Ground the transmitter as instructed below.

**Figure 4-1. Power-supply wiring terminals**

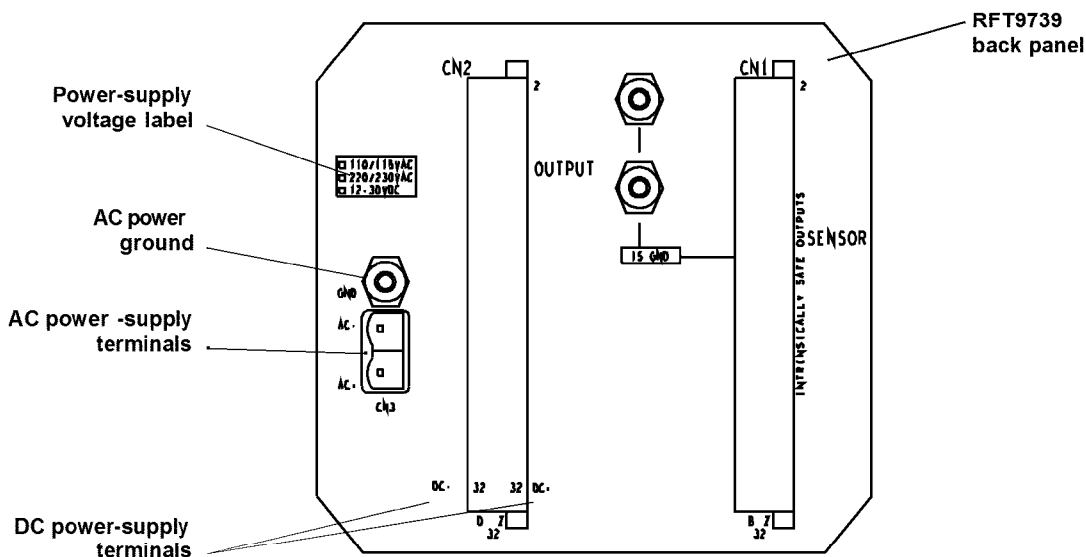

Grounding

**⚠ CAUTION**

**Failure to comply with requirements for intrinsic safety if the sensor is installed in a hazardous area could result in an explosion.**

The transmitter must be properly grounded. Follow the instructions below to ground the transmitter.

To ensure proper grounding:

- If the sensor installation must comply with UL or CSA standards, refer to the instructions in one of the following Micro Motion documents:
  - UL-D-IS Installation Instructions
  - CSA-D-IS Installation Instructions
- To determine which grounding instructions to use, refer to **Table 4-1**.

**Table 4-1.**  
Selecting the proper grounding scheme

Condition	Figure	Page
Sensor is installed in a non-hazardous area	4-2a	19
Sensor is installed in hazardous area, plant does <b>not</b> have a separate intrinsically safe ground system, installations in Europe only	4-2a	19
Sensor is installed in a hazardous area, any area except Europe	4-2b	20
Plant uses a separate, high-integrity, I.S. ground scheme	4-2c	20

**Figure 4-2a. Grounding detail — typical**

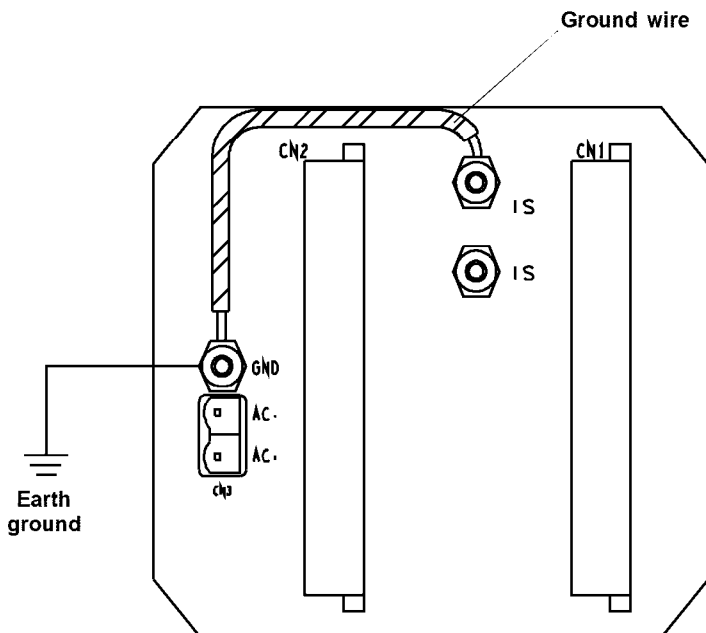

If national standards are not in effect, adhere to these guidelines for grounding:

- Use copper wire, 14 AWG (2.5 mm $\leq$ ) or larger wire size.
- Keep all ground leads as short as possible, less than 1 ohm impedance.
- A factory-installed ground wire, connecting the I.S. ground and power-supply ground terminals, must remain in place.
- Connect power-supply ground directly to earth.
- For hazardous area installation in Europe, use standard EN 60079-14 as a guideline.
- To achieve potential equalization and comply with CENELEC standards for hazardous area installations in Europe, connect power-ground terminal to the appropriate ground terminals within the hazardous area, using a potential equalizing line.

Figure 4-2b. Grounding detail — hazardous-area sensor installations

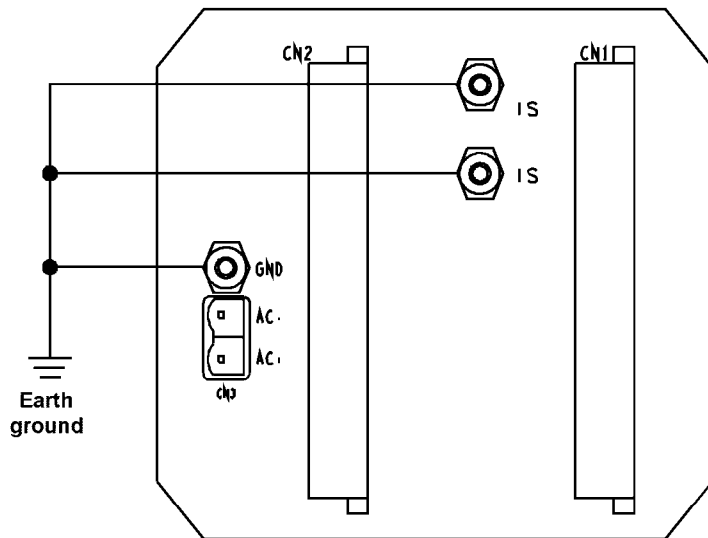

If national standards are not in effect, adhere to these guidelines for grounding:

- Use copper wire, 14 AWG (2.5 mm<sup>2</sup>) or larger wire size.
- Keep all ground leads as short as possible, less than 1 ohm impedance.
- Connect I.S. grounds and power-supply ground directly to earth.

Figure 4-2c. Grounding detail — high-integrity I.S. installations

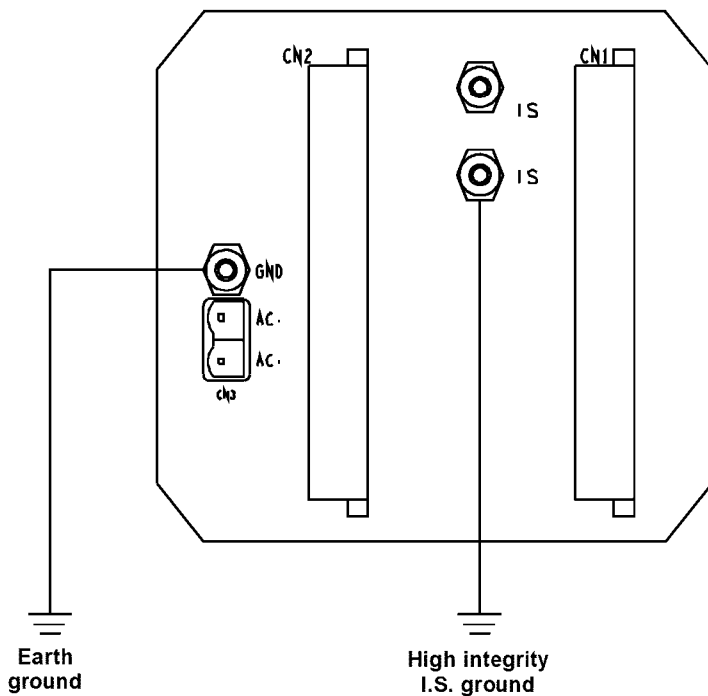

If national standards are not in effect, adhere to these guidelines for grounding:

- Use copper wire, 14 AWG (2.5 mm<sup>2</sup>) or larger wire size.
- Keep all ground leads as short as possible, less than 1 ohm impedance.
- A factory-installed ground wire, connecting the I.S. ground and power-supply ground terminals, must be removed.
- Connect ground lead from power-supply ground terminal directly to earth ground.
- To achieve potential equalization, connect the I.S. ground terminal to the appropriate ground terminals within the hazardous area, using a potential equalizing line.
- I.S. ground wire must not be routed with other wires.

## Power-Supply and Sensor Wiring continued

### Fuses

Fuses for the power-supply input are located inside the transmitter housing on the power board. The transmitter has two fuses: one for an AC power supply and one for a DC power supply.

- The AC power supply uses a UL/CSA 250mA/250V, time-lag, 5x20mm.
- The DC power supply uses a UL/CSA 2A/125V, time-lag, 5x20mm.

To access the AC-power fuse, remove the top cover. To access the DC-power fuse, remove the bottom cover. Locate the power board. The locations of the fuses on the board are indicated in **Figure 4-3**, page 21.

### 4.3 Changing power-supply voltage

A switch labeled S1, located inside the transmitter on the power board (see **Figure 4-3**), allows the AC power-supply voltage to be changed.

#### When switching from AC to DC power:

1. Remove the AC power wiring.
2. Properly install the DC wiring.

#### When switching AC voltage, or when switching from DC to AC power:

1. Turn off power, then detach the existing power-supply wiring.
2. Remove the transmitter top cover.
3. Locate the power board. The location of switch S1 is indicated in **Figure 4-3**.
4. Set switch S1 to the appropriate position (115V or 230V), then replace the top cover on the housing.
5. Mark the newly configured voltage on the label on the transmitter back panel.
6. Properly install the new wiring.

**Figure 4-3. Fuses and power-select switch**

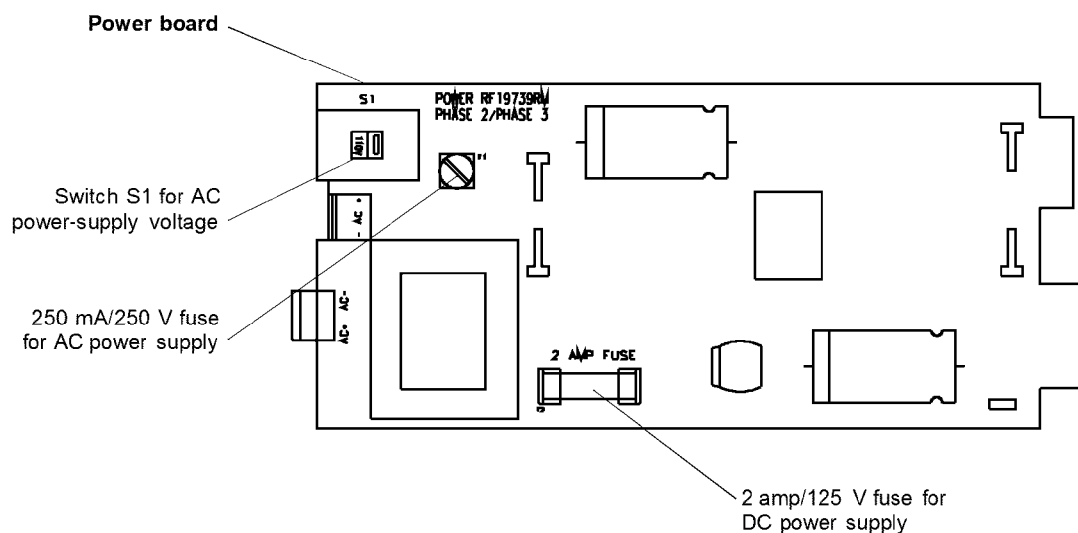

#### 4.4 Sensor wiring

The instructions in this section explain how to connect a fully prepared Micro Motion flowmeter cable to the RFT9739 and a sensor. The sensor can be a Micro Motion ELITE, F-Series, Model D, DL, or DT sensor.

- The procedure for preparing Micro Motion flowmeter cable and cable glands is described in the instructions that are shipped with the cable.
- Install cable and wiring to meet local code requirements.
- Use Micro Motion color-coded cable.
- Total length of cable from the sensor to the transmitter must not exceed 1000 feet (300 meters).

 <b>CAUTION</b>
<p><b>Improper installation of cable or conduit could cause inaccurate measurements or flowmeter failure.</b></p> <p>Keep cable away from devices such as transformers, motors, and power lines, which produce large magnetic fields.</p>

#### Cable connections to sensor and transmitter

 <b>CAUTION</b>
<p><b>Failure to seal sensor junction box could cause a short circuit, which would result in measurement error or flowmeter failure.</b></p> <p>To reduce risk of condensation or excessive moisture in the sensor junction box:</p> <ul style="list-style-type: none"><li>• Seal all conduit openings.</li><li>• Install drip legs in conduit or cable.</li><li>• Fully tighten junction box cover.</li></ul>

The wiring procedure is the same for the sensor and transmitter. Refer to the wiring diagrams on pages 23 through 24, and follow these steps:

1. Insert the stripped ends of the individual wires into the terminal blocks. No bare wires should remain exposed.
  - At the sensor, connect wiring inside the sensor junction box.
  - At the transmitter, connect wiring to the transmitter's intrinsically safe sensor terminals for sensor wiring, as numbered in **Table 4-2**, page 23. The transmitter terminal block can be unplugged for easier connection of wiring.
2. Locate the wires by color as indicated in **Table 4-2**, page 23.
3. Tighten the screws to hold the wires in place.
4. Tightly close the sensor junction-box cover. On an ELITE sensor junction box, tighten all four cover screws.



Power-Supply and Sensor Wiring continued

**Table 4-2.**  
Terminal designations

Wire color	Sensor terminal	Transmitter terminal	Function
Black*	No connection	CN1-Z4	Drain wires*
Brown	1	CN1-Z2	Drive +
Red	2	CN1-B2	Drive -
Orange	3	CN1-B6	Temperature -
Yellow	4	CN1-B4	Temperature return
Green	5	CN1-Z8	Left pickoff +
Blue	6	CN1-Z10	Right pickoff +
Violet	7	CN1-Z6	Temperature +
Gray	8	CN1-B10	Right pickoff -
White	9	CN1-B8	Left pickoff -

\*Combined drain wires from brown/red, green/white, and gray/blue pairs, and yellow/orange/violet triplet. These should be clipped back at the sensor end.

**Figure 4-4. Wiring to ELITE sensors**

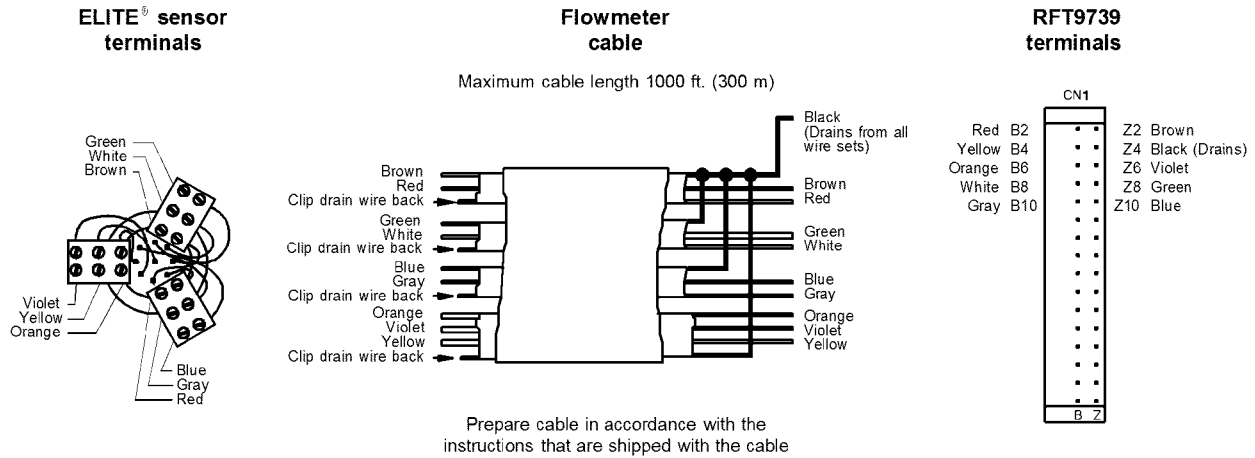

**Figure 4-5. Wiring to F-Series, Model D and DL sensors**

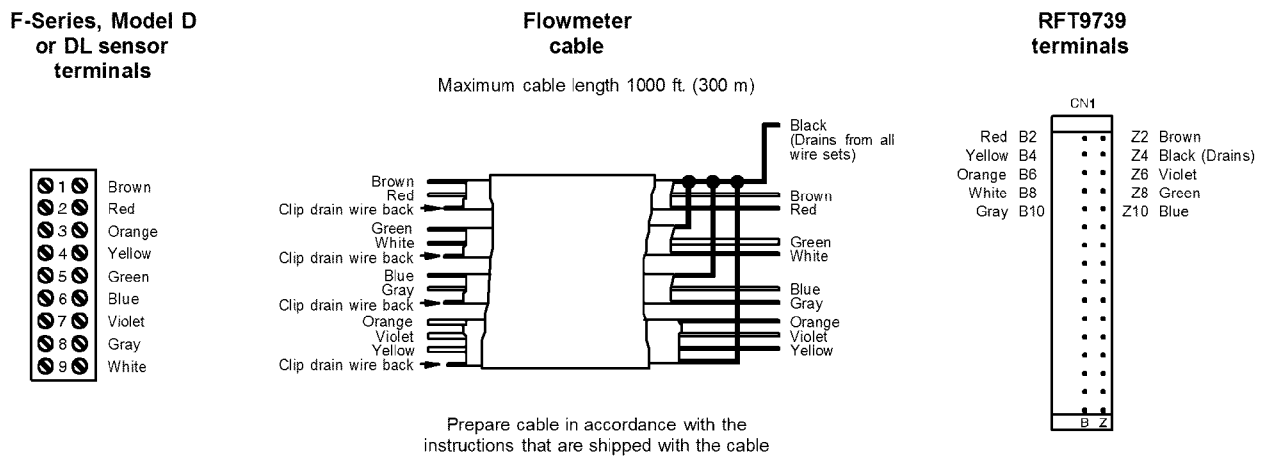
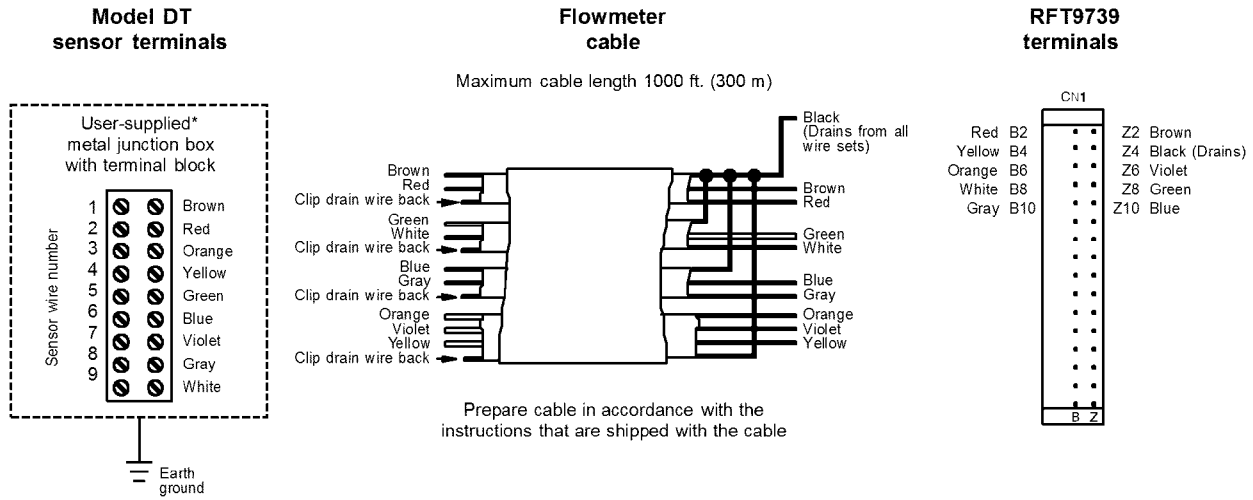

Figure 4-6. Wiring to Model DT sensors



\*In Europe, the DT-sensor junction box is supplied by the factory.

## 5.1 General guidelines

**⚠ WARNING**

**Failure to comply with requirements for intrinsic safety if the sensor is installed in a hazardous area could result in an explosion.**

Output wiring is not intrinsically safe.

- Keep output wiring separated from power-supply wiring and intrinsically safe sensor wiring.
- Follow all output wiring instructions to ensure the transmitter and any connected devices will operate correctly.

Output wiring connects to the terminals on connector CN2. Connector CN2 is not intrinsically safe. **Figure 5-1** and **Table 5-1**, page 26, describe terminal designations on connector CN2, which can be unplugged from the transmitter housing for easier installation of wiring.

- To avoid possible electrical interference, do not install output wiring in the same conduit or cable tray as power-supply wiring or intrinsically safe sensor wiring.
- Use individually shielded pairs of 22 AWG (0.3 mm $\leq$ ) or larger wires for connections between the transmitter and any peripheral device.
- Connect shields of twisted-pairs to terminals CN2-Z4 and/or CN2-D4.
- To comply with CENELEC standards for hazardous area installations in Europe, nonintrinsically-safe connections between the RFT9739 and other devices may **only** be made to devices that maintain a voltage less than or equal to 250 V.

## 5.2 Maximum wire length

Currently, there is no system for accurately estimating the maximum length of wire between the RFT9739 and a connected peripheral device.

Most applications will be able to use wire lengths up to 500 feet for 22 AWG wire (150 meters for 0.3 mm $\leq$  wire), 50 feet for 28 AWG wire (15 meters for 0.1 mm $\leq$  wire), between the transmitter and any peripheral device. However, these distances are estimates only.

Prior to commissioning the transmitter, a loop-test is recommended as a means for determining whether or not output signals are being received correctly at the receiving device.

Output Wiring continued

Figure 5-1.  
Output terminals

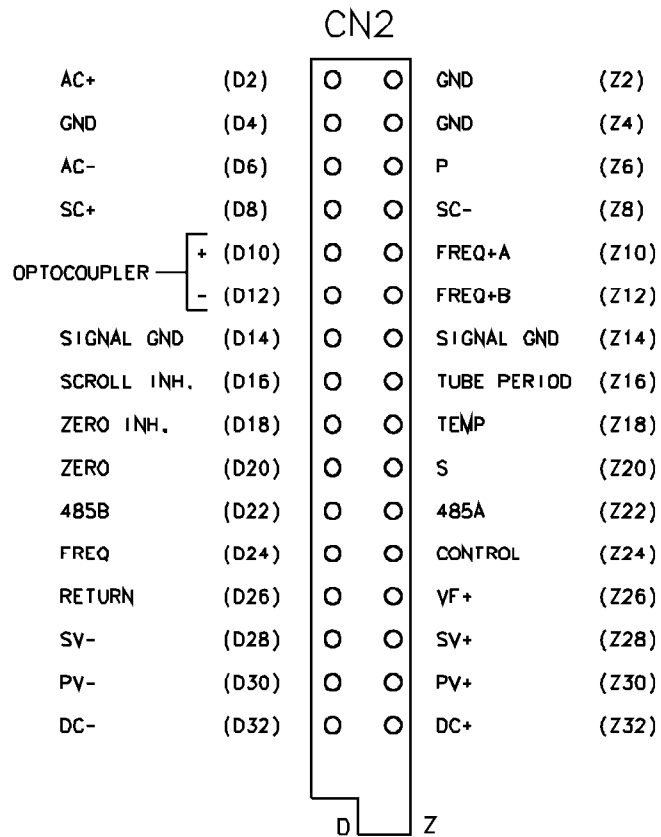

Table 5-1. Output wiring terminal designations

CN2 terminal number	Function	CN2 terminal number	Function
D4, Z2 and Z4	Grounds	Z6	DC power to pressure or DP transmitter
D10 and D12	Optocoupler output	Z10 and D26	Dual-channel (quadrature) frequency output, channel A
D14 and Z14	Signal ground	Z12 and D26	Dual-channel (quadrature) frequency output, channel B
D16 and D14	Scroll inhibit	Z16 and Z14	Tube period output
D18 and D14	Zero inhibit	Z18 and Z14	Temperature output
D20 and D26	Remote zero input	Z20	mA input from pressure or DP transmitter
D22 and Z22	RS-485 I/O	Z24 and D26	Control output
D24 and D26	Frequency/pulse output	Z26	Frequency output, DC supply voltage
D28 and Z28	Secondary variable (SV) mA output		
D30 and Z30	Primary variable (PV) mA output		
D32 and Z32	DC power-supply input		

**5.3 Primary and secondary mA outputs**

The RFT9739 primary and secondary mA output signals can be independently configured, and can represent flow, density, temperature, event 1 or event 2. With a pressure transmitter, the primary and secondary mA output signals can also represent pressure. For information on configuring mA outputs for events, see any of the following manuals or AMS on-line help:

- Using the HART Communicator with Micro Motion Transmitters
- Using ProLink Software with Micro Motion Transmitters
- Using Modbus Protocol with Micro Motion Transmitters

The mA outputs can produce a user-selected 0-20 or 4-20 mA current. (See "Milliamp output scaling," page 9.)

- When configured to produce 4-20 mA current, the mA output loop can supply loop-powered process indicators.
- **For transmitters with software version 3.8 or higher**, when configured to produce 4-20 mA current, the mA outputs are compliant with the NAMUR NE43 standard. (All RFT9739 transmitters shipped after November 1999 have software version 3.8 or higher.)

**⚠ CAUTION**

**Milliamp output range has changed.**

When configured for 4-20 mA, milliamp outputs will not output live signals between 2.0 and 3.8 mA, or between 20.5 and 22 mA.

Systems that rely on milliamp output signals in the ranges listed above might not perform as expected. For RFT9739 transmitters shipped after November 1999, outputs will saturate at 3.8 and 20.5 mA, unlike previous versions of these instruments.

Reconfigure systems as necessary.

In compliance with the NAMUR NE43 standard:

- 4-20 mA outputs will produce a live signal from 3.8 to 20.5 mA.
- 4-20 mA outputs will not produce a signal between 2.0 and 3.8 mA, or between 20.5 and 22 mA.
- 4-20 mA output performance is illustrated in **Figure 5-2**.

**Figure 5-2. 4-20 mA output performance**



Use RFT9739 terminals CN2-D30 and CN2-Z30 for the primary mA output. Use terminals CN2-D28 and CN2-Z28 for the secondary mA output. See **Figure 5-3**.

- Primary and secondary mA output loops are isolated and floating. Additional grounding will result in optimum performance, and optimum HART communication on the primary mA output. Ensure that mA output loops are grounded properly, either at the transmitter end, or at the external device.
- The maximum allowable length for mA signal wiring is determined by measuring resistance over the signal wires and through the receiver device. Total loop resistance must not exceed 1000 ohms.
- The primary mA output must be set to the 4-20 mA mode for the Bell 202 physical layer. The Bell 202 layer will not work with the primary mA output configured as a 0-20 mA output.
- The mA output is active and cannot be converted to passive.

**Figure 5-3.**  
Primary and secondary  
mA output wiring

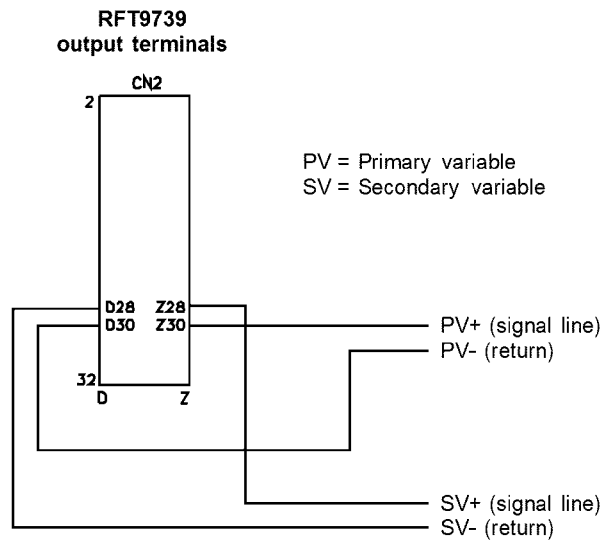

## Output Wiring continued

## Connections for HART® communication devices

**Figure 5-4** illustrates how to connect a HART Communicator, the ProLink PC-Interface adaptor, or an AMS modem to the RFT9739 for digital communication over the primary mA output. For information about using the HART Communicator or ProLink program, see the appropriate instruction manual. For information about using AMS software, see the AMS on-line help.

Figure 5-4. HART® Communicator, ProLink® PC-Interface, and AMS modem connections

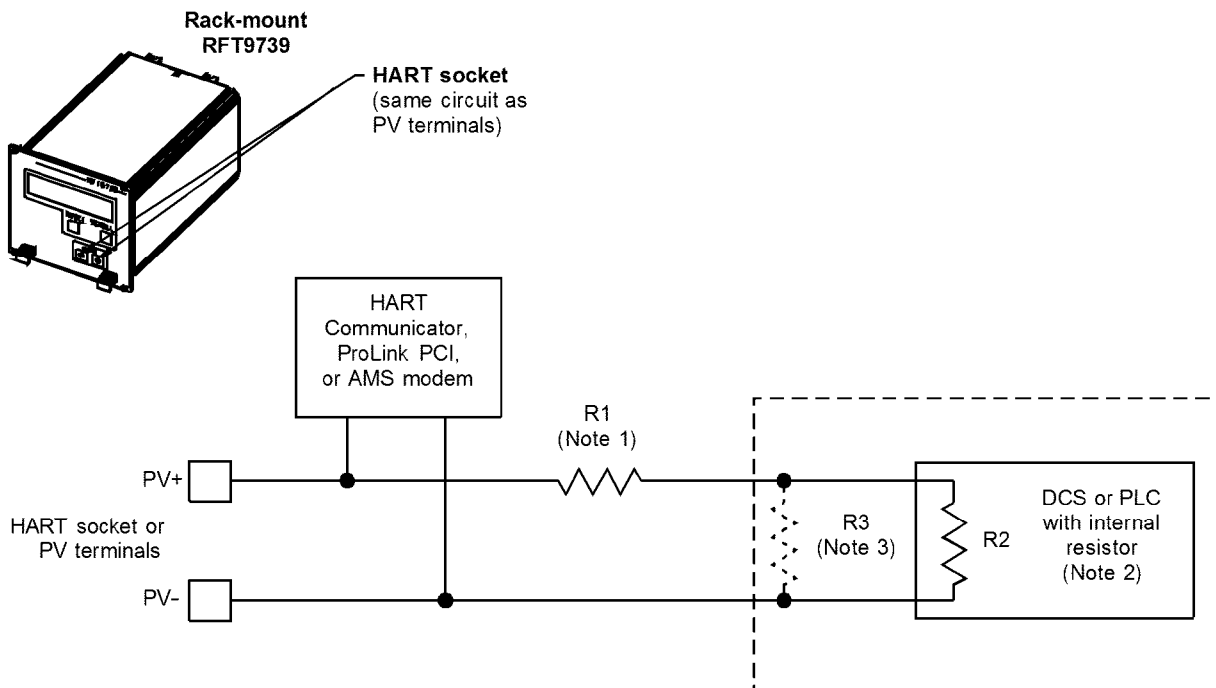

1. If necessary, add resistance in the loop by installing resistor R1. SMART FAMILY® devices require a minimum loop resistance of 250 ohms. Loop resistance must not exceed 1000 ohms, regardless of the communication setup.

### ⚠ CAUTION

**Connecting a HART device to the RFT9739 primary variable milliamp output loop could cause transmitter output error.**

If the primary variable (PV) analog output is being used for flow control, connecting a HART device to the output loop could cause the transmitter 4-20 mA output to change, which would affect flow control devices.

Set control devices for manual operation before connecting a HART device to the RFT9739 primary variable milliamp output loop.

2. The DCS or PLC must be configured for an active milliamp signal.
3. Resistor R3 is required if the DCS or PLC does not have an internal resistor.

## 5.4 Frequency outputs

The RFT9739 frequency outputs include a frequency/pulse output, a dual-channel phase-shifted frequency output for custody transfer applications, and an optocoupler output.

- The frequency output loops are isolated and floating from other circuits except the control output and external-zero input circuits. Ensure that frequency output loops are grounded properly, either at the transmitter end, or at the external device.
- The frequency output circuit uses a 2.2 kohm resistor tied to a 15-volt source that limits the current to 7 mA. The output circuit is rated to 30 VDC, with 0.1 ampere maximum sinking capability, when used in open collector mode. Open collector mode is described on page 33.
- The output is a nominal +15 V or +30 V square wave, unloaded. See "Setting voltage level for VDE output requirements," page 37.
- Output impedance is 2.2 kohm.
- For use with receivers other than Micro Motion peripheral devices, check the instruction manual for the receiver to make sure its input-voltage and electrical-current ratings match the RFT9739 ratings.

### Frequency/pulse output

The frequency/pulse output represents the flow rate, independent of the primary and secondary mA outputs. The frequency/pulse output can be used with all Micro Motion peripheral devices except the DMS Density Monitoring System and the PI 4-20 Process Indicator, which do not have frequency inputs.

The RFT9739 frequency/pulse output can be configured to provide any one of the following:

- Mass flow rate
- Volume flow rate
- Mass flow total
- Volume flow total

Mass flow total and volume flow total are not available with some RFT9739 transmitters shipped prior to 1998.

Use RFT9739 terminals CN2-D24 and CN2-D26 for the frequency/pulse output. Terminal D26 serves as a common return for the frequency/pulse output, dual-channel frequency output, control output, and remote zero input. See **Figure 5-5**, page 31.



### Output Wiring continued

#### Default configuration

When the RFT9739 is shipped from the factory, the frequency/pulse output is internally powered by an isolated 15-volt source via a 2.2 kohm pull-up resistor. This internal current is limited to approximately 7 mA. See **Figure 5-5**.

**Figure 5-5.**  
Frequency/pulse output wiring

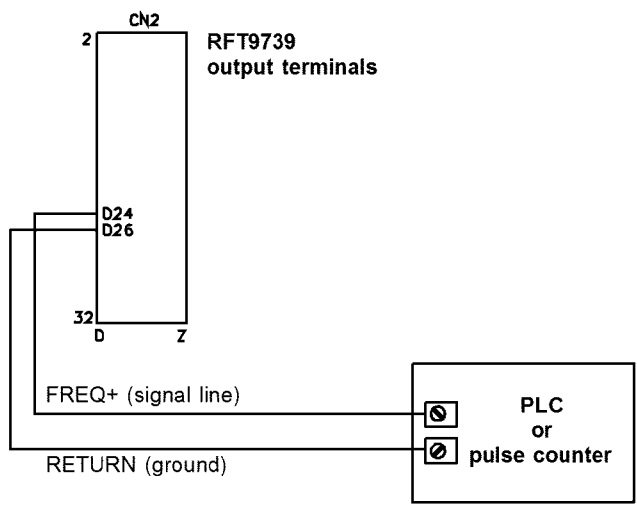

#### Configuration for increased current

In some applications, it might be necessary to increase the current in the frequency/pulse output circuit. See **Section 5.2**, page 25. For increased current to the circuit, add a 1 to 3 kohm resistor across terminals CN2-Z26 and CN2-D24, as illustrated in **Figure 5-6**.

**Figure 5-6.**  
Frequency/pulse output wiring for increased current

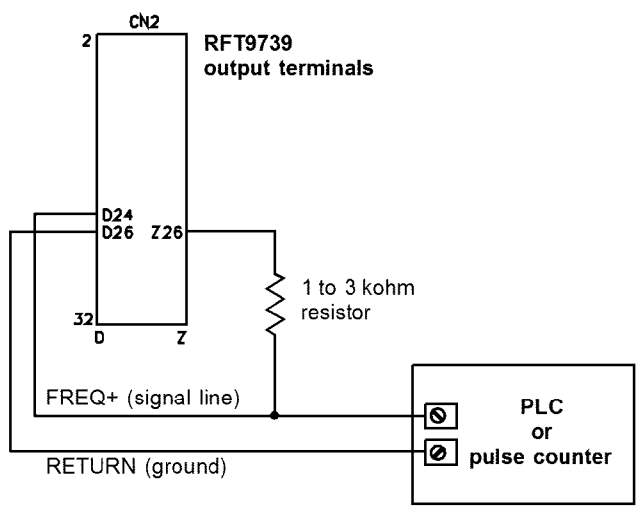

**Configuration for constant current**

Applications with high capacitance loading will benefit by wiring the frequency/pulse output circuit to maintain a constant current source of 50 mA for any load between 0 and 220 ohms. This configuration renders the control output circuit inoperable, and could affect the optocoupler and dual-channel frequency outputs.

For constant current, add a jumper across terminals CN2-Z26 and CN2-D24, and a 100 to 250 ohm resistor at the PLC or pulse-counter end of the cable, as illustrated in **Figure 5-7**.

**⚠ CAUTION**

**Adding a jumper across terminals CN2-Z26 and CN2-D24 renders the control output circuit inoperable.**

Do not attempt to use the control output circuit after you add a jumper across terminals CN2-Z26 and CN2-D24.

The control output can be reconfigured to function properly, independent of this frequency/pulse wiring procedure. See "Control output in open collector mode," page 41.

The optocoupler and dual-channel frequency outputs could be affected by configuring the frequency/pulse output for constant current as described above. To reduce this risk, use a 250 ohm resistor, as indicated in **Figure 5-7**.

**Figure 5-7.**  
Frequency/pulse output wiring for constant current

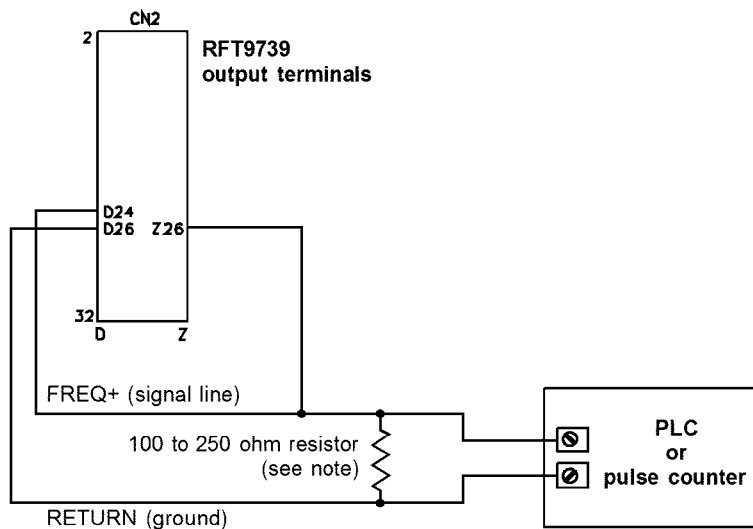

To use the dual-channel frequency output or the optocoupler output with this configuration, use only a 250 ohm resistor.

**Configuration for open collector mode**

The RFT9739 provides current to the frequency/pulse output circuit. In applications where this current must be permanently suspended, and for receiving devices that require input voltage higher than approximately 10 volts, the frequency/pulse output circuit can be used in open collector mode.

To configure the output for open collector mode, a resistor must be clipped as described below. **This procedure will permanently alter the transmitter and cannot be reversed.**

- Clip resistor R5 and add an external DC power supply and a pull-up resistor. See **Figure 5-8**, page 34.
- The pull-up resistor must be of sufficient value to limit loop current to less than 0.1 ampere, depending on the total loop resistance at the transmitter.
- To prevent damage to the optocoupler and dual-channel frequency output circuits, the external voltage must not exceed 15 V.
- Resistor R5 is located on the inside of the RFT9739 back panel.

**⚠ CAUTION**

**Clipping resistor R5 will eliminate the internal voltage source from the transmitter.**

After clipping resistor R5, an external power supply is required to use the transmitter's frequency/pulse output.

Before permanently altering any equipment, contact the Micro Motion Customer Service:

- In the U.S.A., phone 1-800-522-6277, 24 hours
- Outside the U.S.A., phone 303-530-8400, 24 hours
- In Europe, phone +31 (0) 318 549 443
- In Asia, phone 65-770-8155

To access resistor R5, refer to **Figure 5-9**, page 34, and follow these steps:

1. Remove the bottom cover of the transmitter housing.
2. Remove the back panel, and carefully pull it loose from the power board and the control board.
3. Locate and clip resistor R5 on the inside of the RFT9739 back panel. See **Figure 5-10**, page 35.
4. Reinstall the bottom cover.
5. Reinstall the back panel, carefully aligning the connector pins with the connectors on the power board and the control board.

**Figure 5-8.**  
Frequency/pulse output  
wiring for open collector  
mode

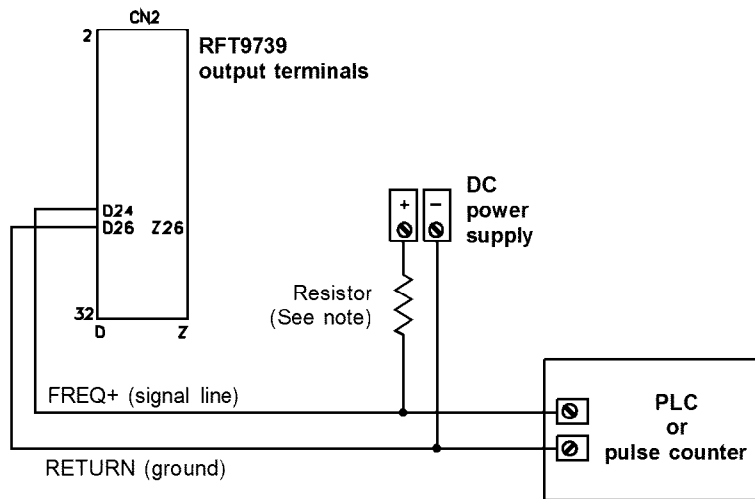

Resistor must be of sufficient value to limit loop current to less than 0.1 ampere, depending on total loop resistance.

**Figure 5-9.**  
RFT9739 back panel

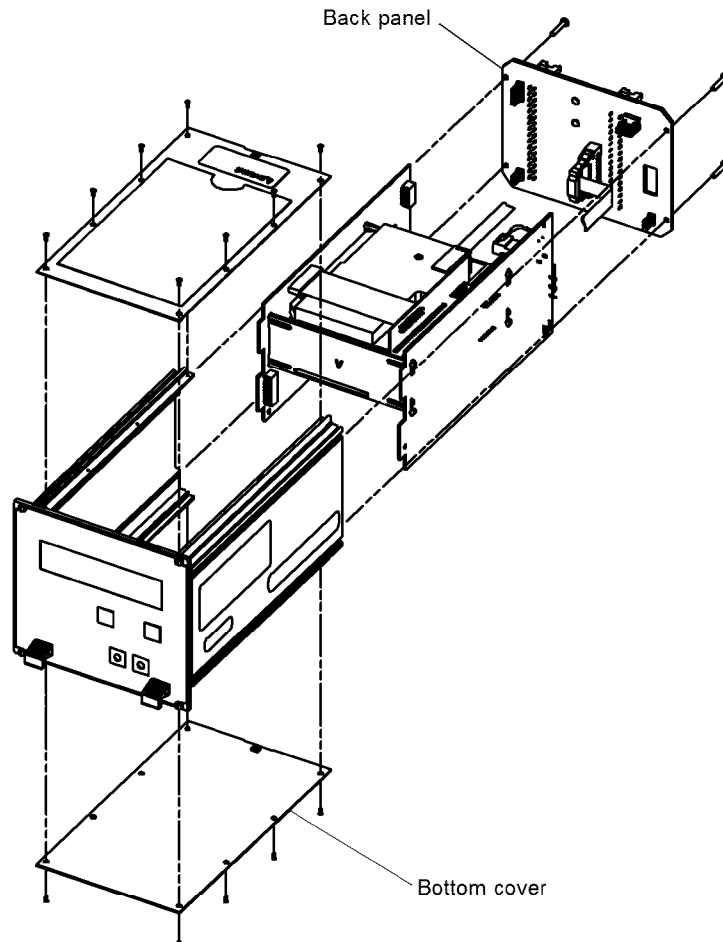
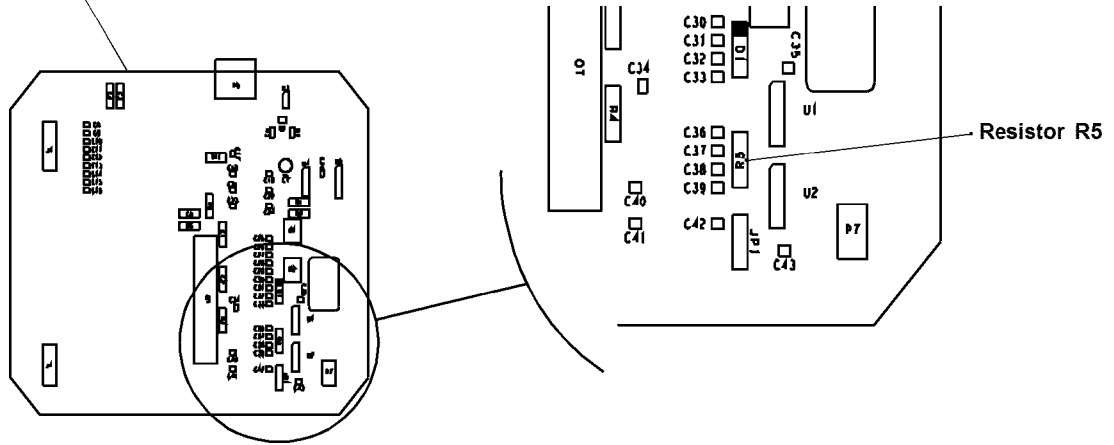

Figure 5-10. Resistor R5 on inside of back panel

Inside of back panel



**Dual-channel frequency output**

The transmitter has a dual-channel, phase-shifted frequency output for custody transfer applications. The dual-channel frequency is derived from the frequency/pulse output, and represents the same flow rate as the frequency/pulse output. Each dual-channel frequency is always half the value of the frequency/pulse output. For example, if the frequency/pulse output is 4,000 Hz, each dual-channel output is 2,000 Hz. The phase shift between channels is 90 degrees.

Use RFT9739 terminals CN2-Z10, CN2-Z12, and CN2-D26 for the dual-channel frequency output. Terminal D26 serves as a common return for the dual-channel frequency output, frequency/pulse output, control output, and remote zero input. See **Figure 5-11**.

**Figure 5-11. Dual-channel frequency output wiring**

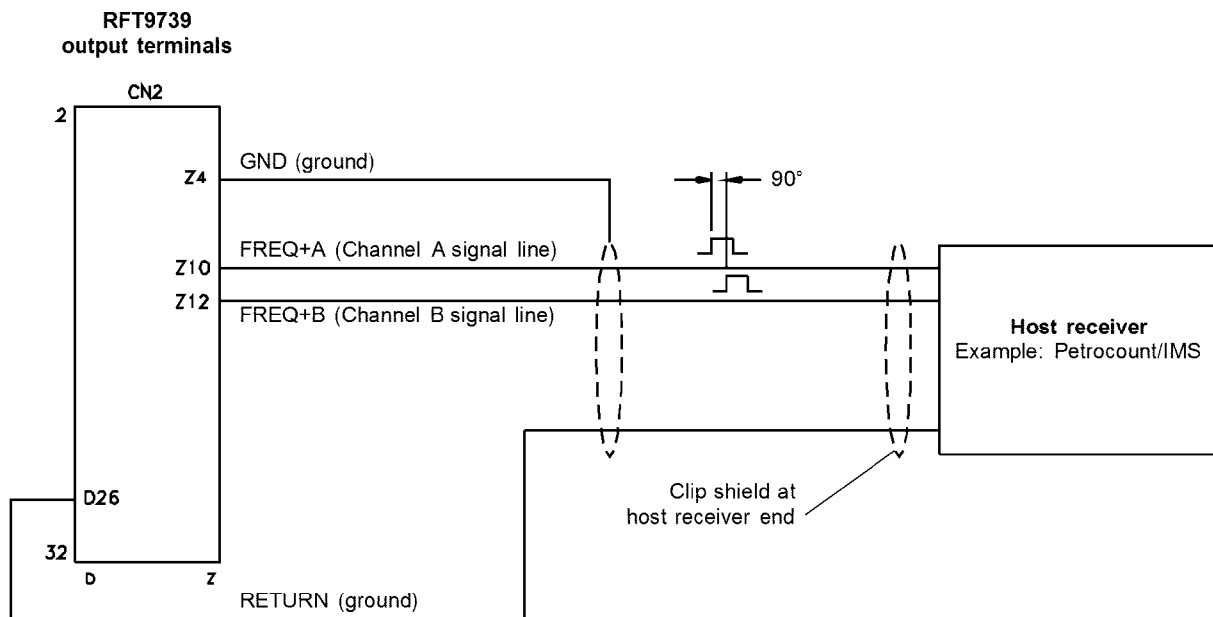

### Setting voltage level for VDE output requirements

To set the voltage level to 30 volts to meet VDE requirements for the frequency/pulse output and dual-channel frequency output:

1. Remove the bottom cover of the transmitter housing.
2. Remove the back panel, and carefully pull it loose from the power board and the control board. See **Figure 5-12**.
3. Locate jumper J10 on the power board, which is illustrated in **Figure 5-13**, page 38. Locate jumper JP1 on the inside of the back panel, which is illustrated in **Figure 5-14**, page 38.
4. Both jumpers are labeled to show a position for standard 15 volt operation (STD) and 30 V operation (VDE) to meet VDE output requirements. Set both jumpers to the same position.
  - With the jumper on the center pin and the pin labeled VDE, the output is set for 30 volts. Set the output to the VDE position to meet VDE output requirements.
  - With the jumper on the center pin and the pin labeled STD, the output is set for 15 volts. Unless the output must meet VDE requirements, set the output to the STD position.
5. Reinstall the bottom cover.
6. Reinstall the back panel, carefully aligning the connector pins with the connectors on the power board and the control board.

**Figure 5-12.**  
RFT9739 back panel and power board

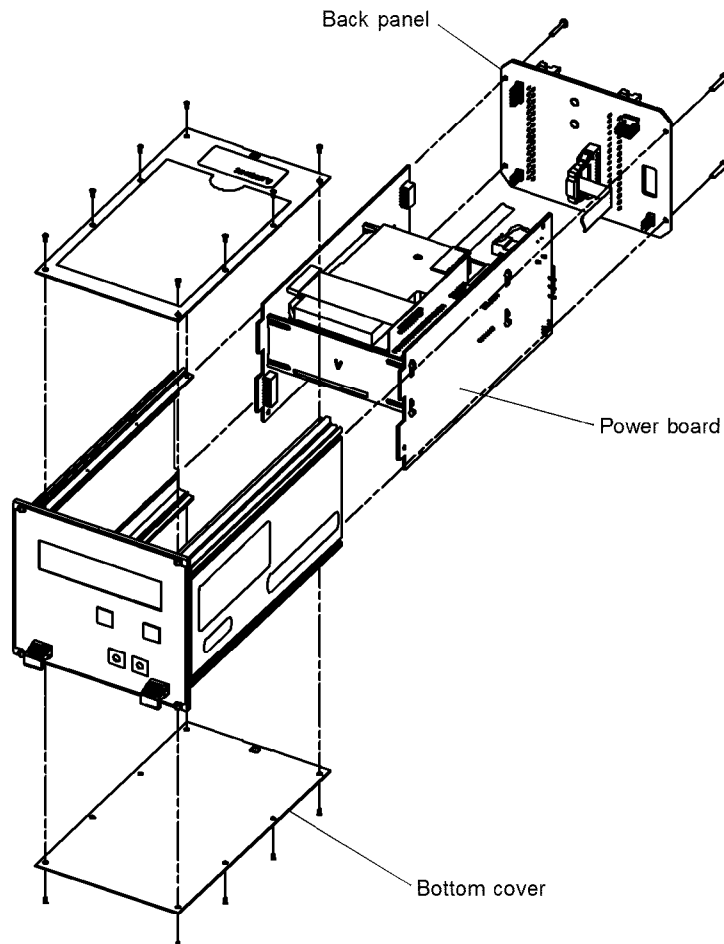

Figure 5-13. Jumper J10 on power board

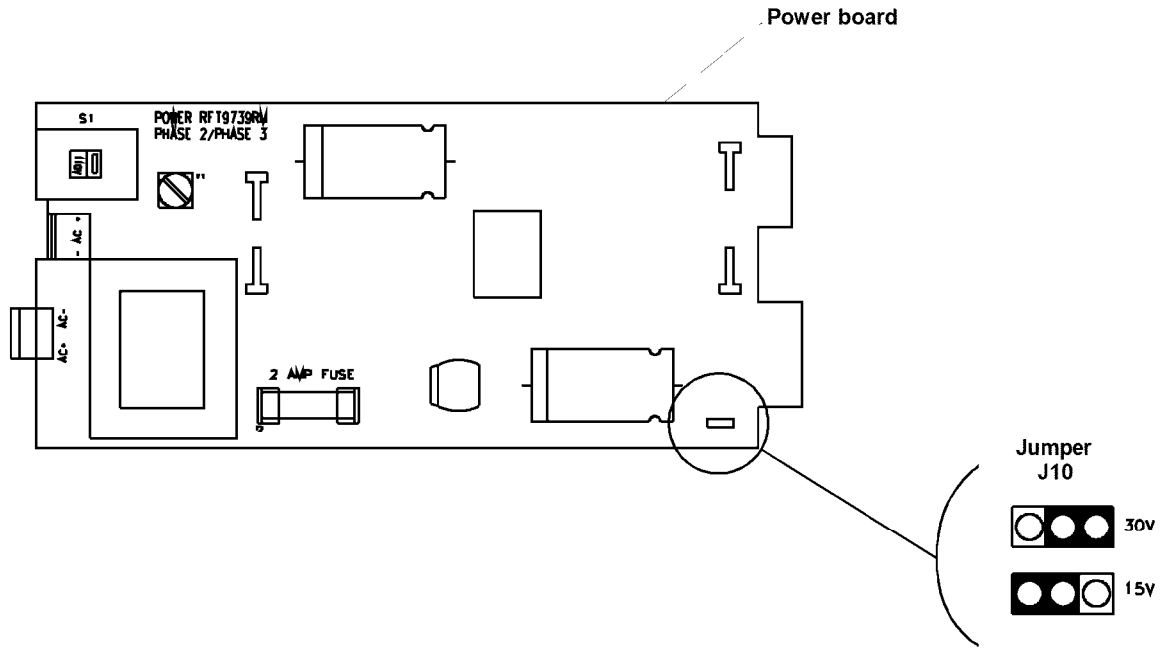
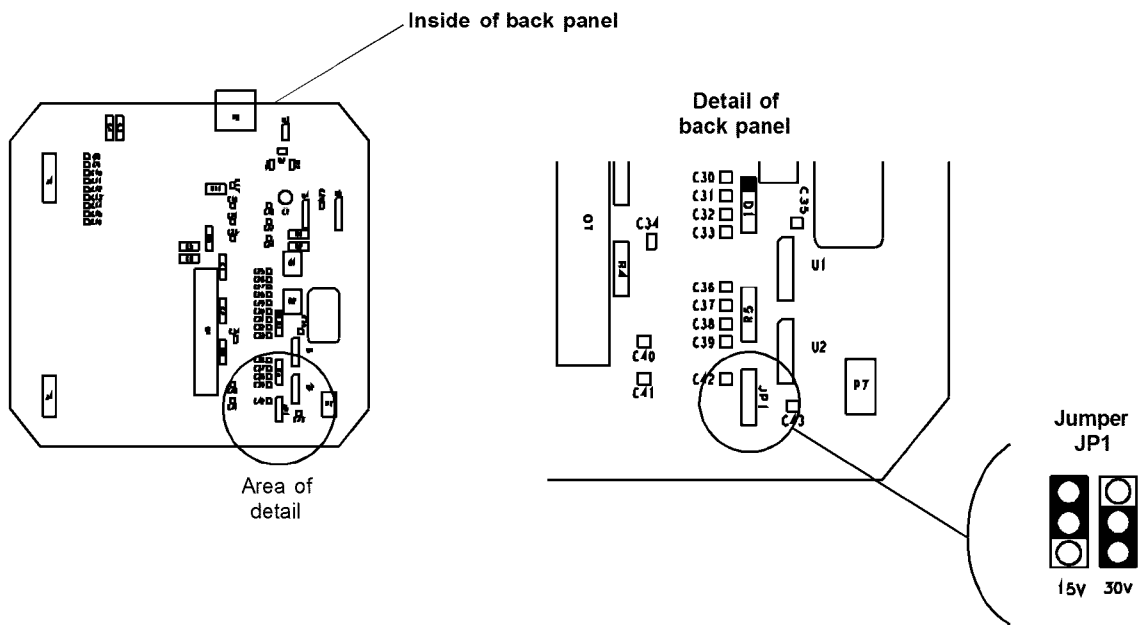

Figure 5-14. Jumper JP1 on inside of back panel





### Output Wiring continued

#### Optocoupler output

The transmitter has an externally powered passive optocoupler output in addition to the frequency/pulse and dual-channel frequency outputs. The optocoupler output is derived from the primary frequency output, and represents the same flow rate variable as the frequency/pulse output.

Use RFT9739 terminals CN2-D10, CN2-D12, and CN2-D4 for the optocoupler output.

- **Figure 5-15** illustrates the wiring connection from the optocoupler output to an auxiliary device.
- Signal voltage is 0-2 VDC low, 16-30 VDC high, with a 0.01 ampere maximum sinking capability.

Figure 5-15. Optocoupler output wiring

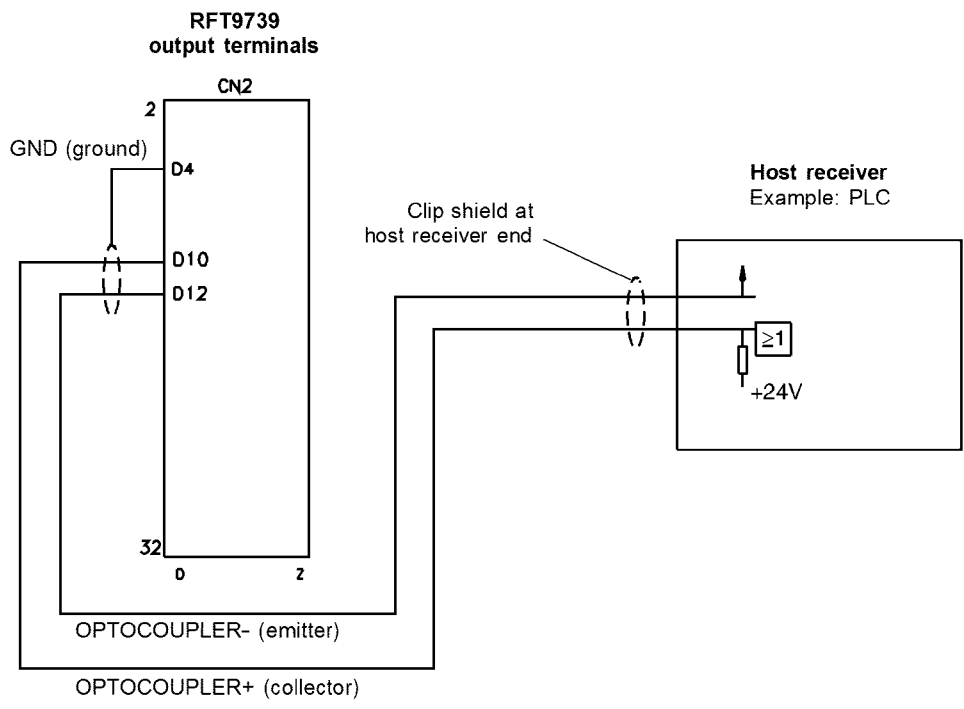

### 5.5 Control output

The control output can indicate flow direction, transmitter zeroing in progress, faults, event 1 or event 2. For information on configuring the control output for events, see any of the following manuals or AMS on-line help:

- Using the HART Communicator with Micro Motion Transmitters
- Using ProLink Software with Micro Motion Transmitters
- Using Modbus Protocol with Micro Motion Transmitters

Use RFT9739 terminals CN2-Z24 and CN2-D26 for the control output. Terminal D26 serves as a common return for the control output, frequency/pulse output, dual-channel frequency output, and remote zero input. See **Figure 5-16**.

- When configured to indicate flow direction, the output is high (+15 VDC) when indicating forward flow, and low (0 VDC) when indicating reverse flow.
- When configured to indicate transmitter zeroing in progress, the output is low (0 VDC) when zeroing is in progress and high (+15 VDC) at all other times.
- When configured to indicate faults, the output is low (0 VDC) when a fault condition exists and high (+15 VDC) during normal operation.
- When configured to indicate event 1 or event 2, the output switches ON (0 VDC) or OFF (+15 VDC) when the flow rate, flow total, density, temperature, or pressure of the process fluid achieves a programmed setpoint.
- The output circuit is rated to 30 VDC, with 0.1 ampere maximum sinking capability, when used in open collector mode. Open collector mode is described on page 41.
- Transmitter output is nominal 0 or +15 VDC, unloaded.
- Output impedance is 2.2 kohm.

**Figure 5-16.**  
Control output wiring

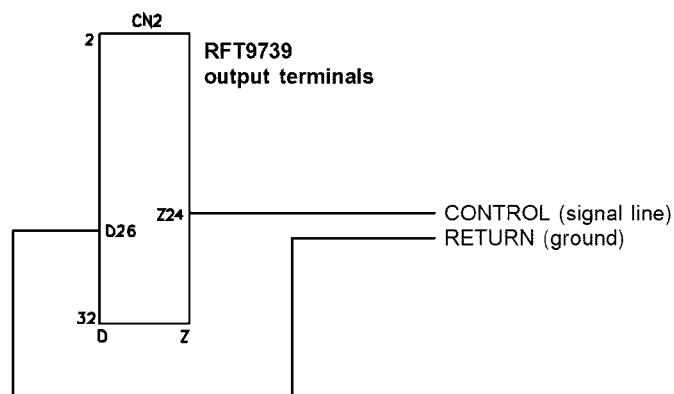

### Control output in open collector mode

The RFT9739 provides current to the control output circuit. In applications where this current must be permanently suspended, and for receiving devices that require input voltage higher than approximately 10 volts, the control output circuit can be used in open collector mode.

If the frequency/pulse output is configured for constant current (see "Configuration for open collector mode," page 33), the control output is rendered inoperable. To reconfigure the control output to function properly, independent of this frequency/pulse output configuration, the control output circuit can be configured for open collector mode.

To configure the control output for open collector mode, a resistor must be clipped as described below. **This procedure will permanently alter the transmitter and cannot be reversed.**

- Clip resistor R4 and add an external DC power supply and a pull-up resistor. See **Figure 5-17**, page 42.
- The pull-up resistor must be of sufficient value to limit loop current to less than 0.1 ampere, depending on the total loop resistance at the transmitter.
- To prevent damage to the optocoupler and dual-channel frequency output circuits, the external voltage must not exceed 15 V.
- Resistor R4 is located on the inside of the RFT9739 back panel.

**⚠ CAUTION**

**Clipping resistor R4 will eliminate the internal voltage source from the transmitter.**

After clipping resistor R4 an external power supply is required to use the transmitter's control output.

Before permanently altering any equipment, contact the Micro Motion Customer Service:

- In the U.S.A., phone 1-800-522-6277, 24 hours
- Outside the U.S.A., phone 303-530-8400, 24 hours
- In Europe, phone +31 (0) 318 549 443
- In Asia, phone 65-770-8155

To access resistor R4, refer to **Figure 5-18**, page 42, and follow these steps:

1. Remove the bottom cover of the transmitter housing.
2. Remove the back panel, and carefully pull it loose from the power board and the control board.
3. Locate and clip resistor R4 on the inside of the RFT9739 back panel. See **Figure 5-19**, page 43.
4. Reinstall the bottom cover.
5. Reinstall the back panel, carefully aligning the connector pins with the connectors on the power board and the control board.

**Figure 5-17.**  
Control output wiring for open collector mode

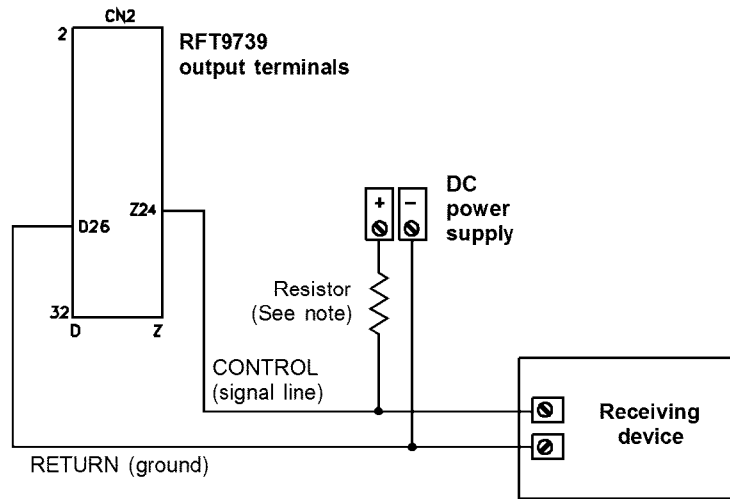

Resistor must be of sufficient value to limit loop current to less than 0.1 ampere, depending on total loop resistance.

**Figure 5-18.**  
RFT9739 back panel

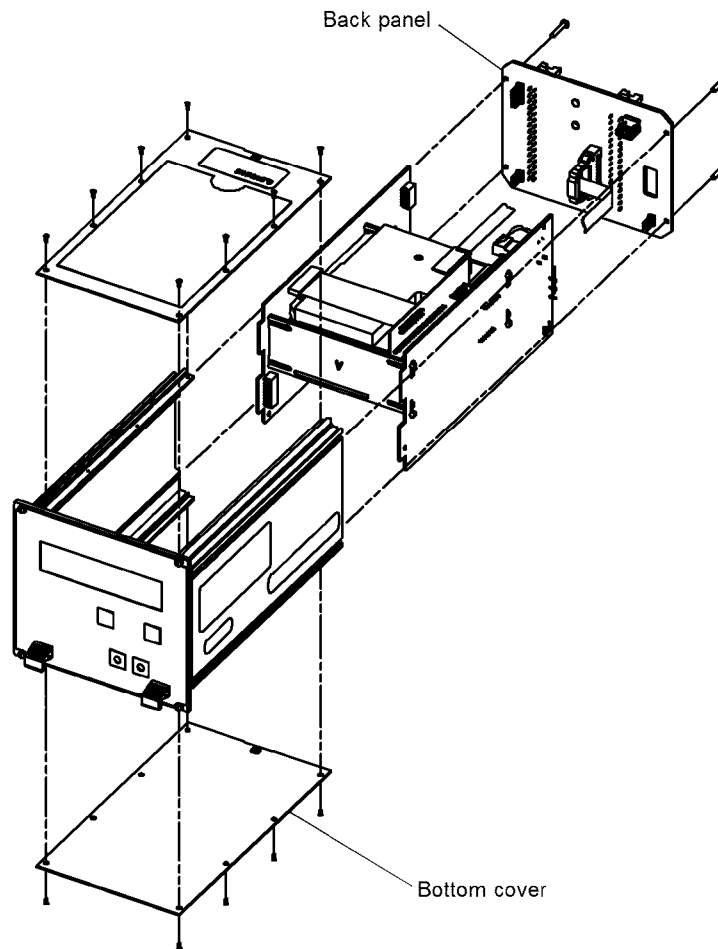

Output Wiring continued

Figure 5-19. Location of resistor R4 on inside of back panel

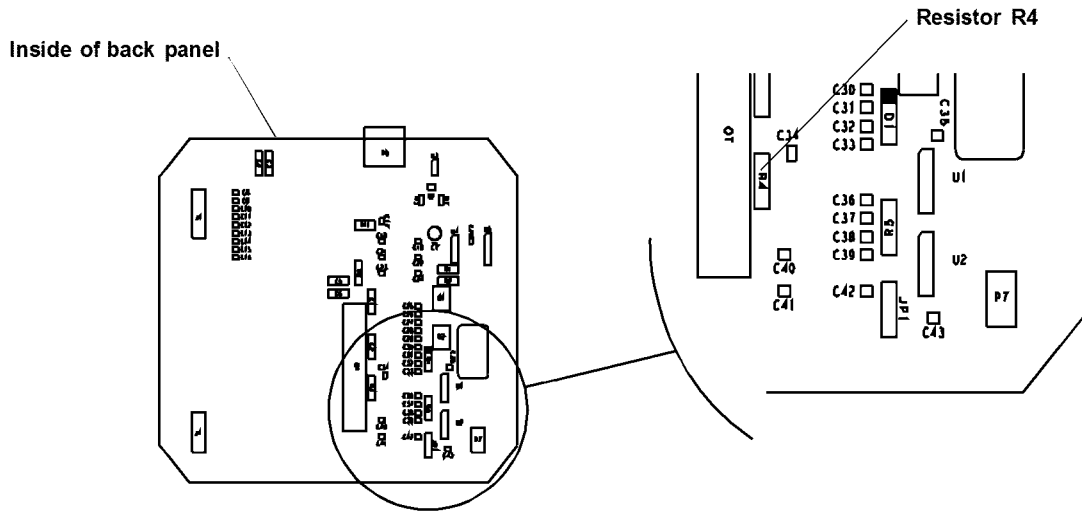

5.6 Peripheral device wiring

The wiring diagrams listed in **Table 5-2** illustrate connections from the transmitter to Micro Motion peripheral devices.

**Table 5-2.**  
Peripheral wiring diagrams

Micro Motion peripheral device	Figure	Page
DMS Density Monitoring System	5-20	44
DRT Digital Rate Totalizer with LED display	5-21a	45
DRT Digital Rate Totalizer with LCD display	5-21b	45
FMS-3 Flow Monitoring System with LED display	5-22a	46
FMS-3 Flow Monitoring System with LCD display	5-22b	46
NFC Net Flow Computer	5-23	47
NOC Net Oil Computer with AC power supply	5-24a	48
NOC Net Oil Computer with DC power supply	5-24b	48
Model 3300 Discrete Controller with screw/solder terminals	5-25a	49
Model 3300 Discrete Controller with I/O cable	5-25b	49
Model 3350 Discrete Controller	5-26	50

**Figure 5-20. Wiring to DMS**

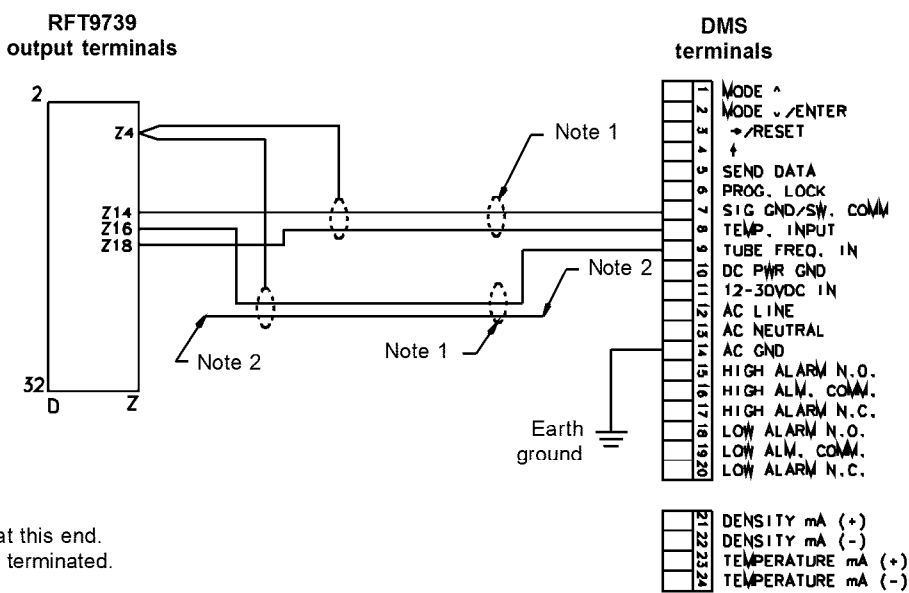

Output Wiring continued

Figure 5-21a. Wiring to DRT with LED

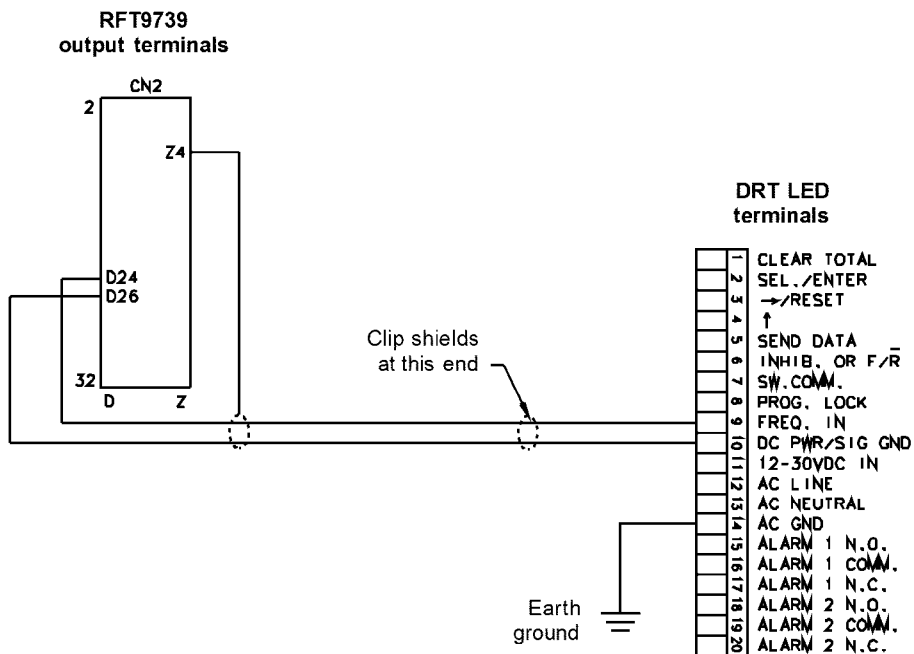

Figure 5-21b. Wiring to DRT with LCD

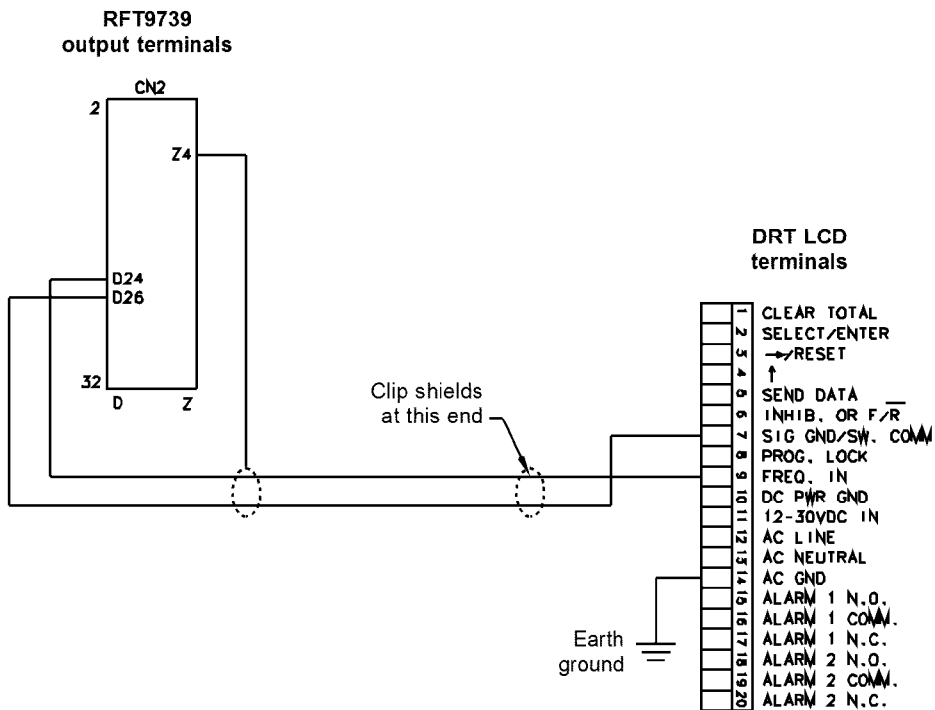

Figure 5-22a. Wiring to FMS-3 with LED

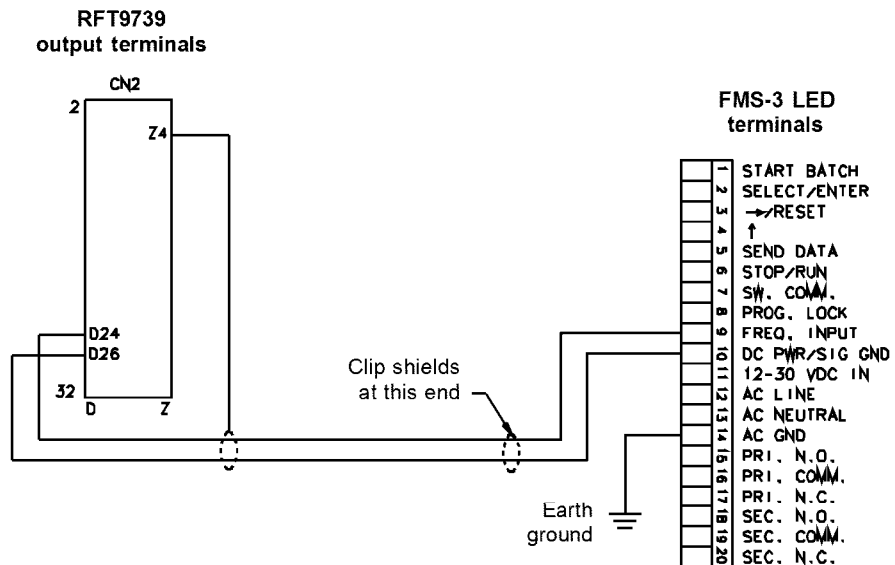
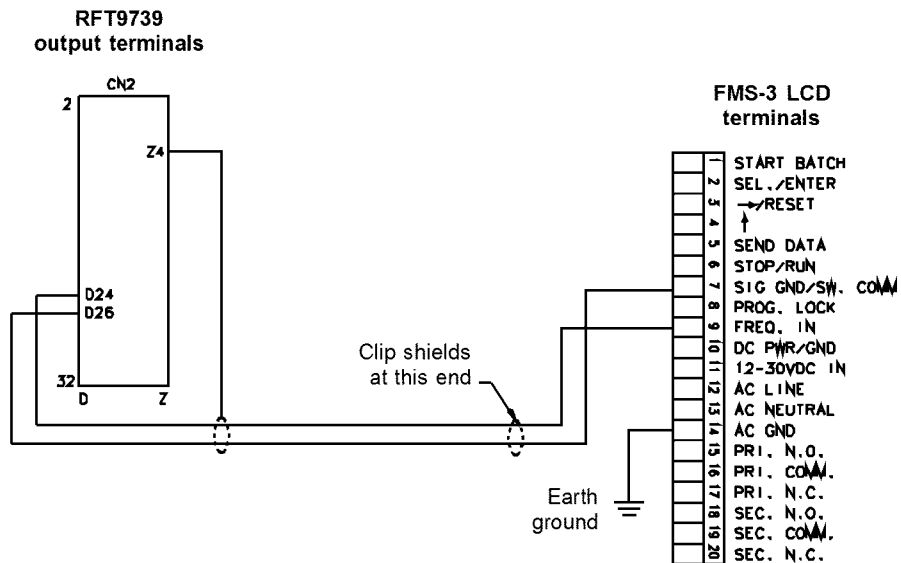

Figure 5-22b. Wiring to FMS-3 with LCD





# Output Wiring continued

## Figure 5-23. Wiring to NFC

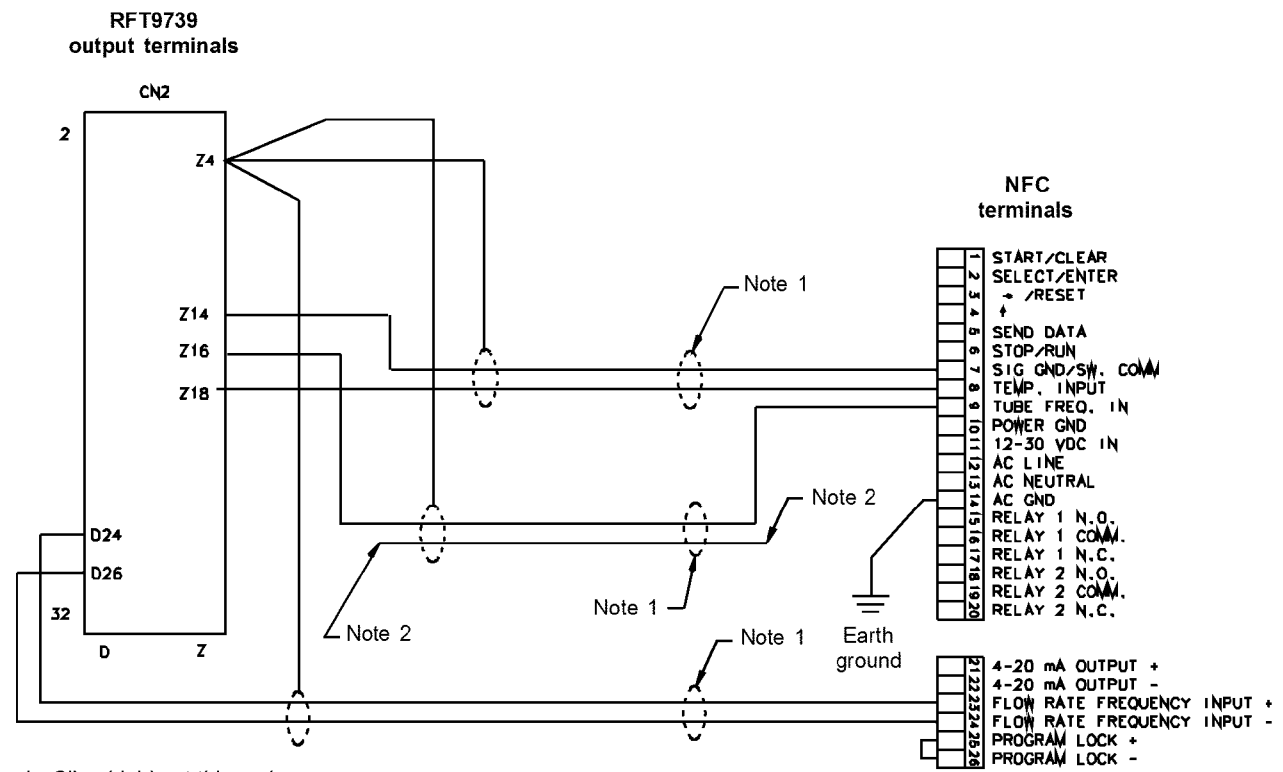

1. Clip shields at this end.
2. This wire not terminated.

Output Wiring continued

Figure 5-24a. Wiring to AC-powered NOC

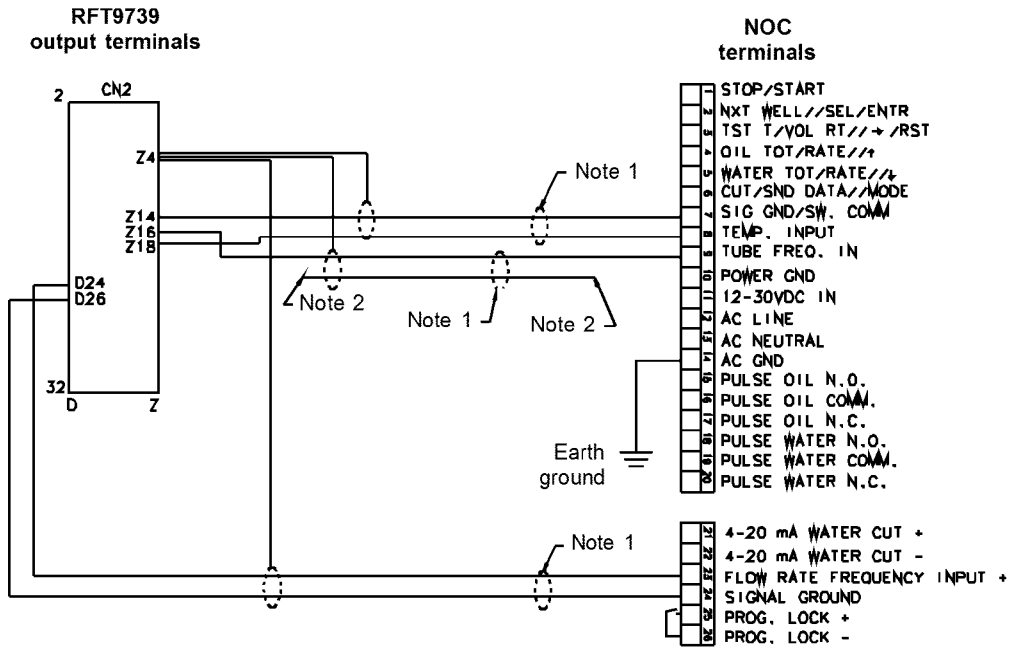

1. Clip shields at this end.
2. This wire not terminated.

Figure 5-24b. Wiring to DC-powered NOC

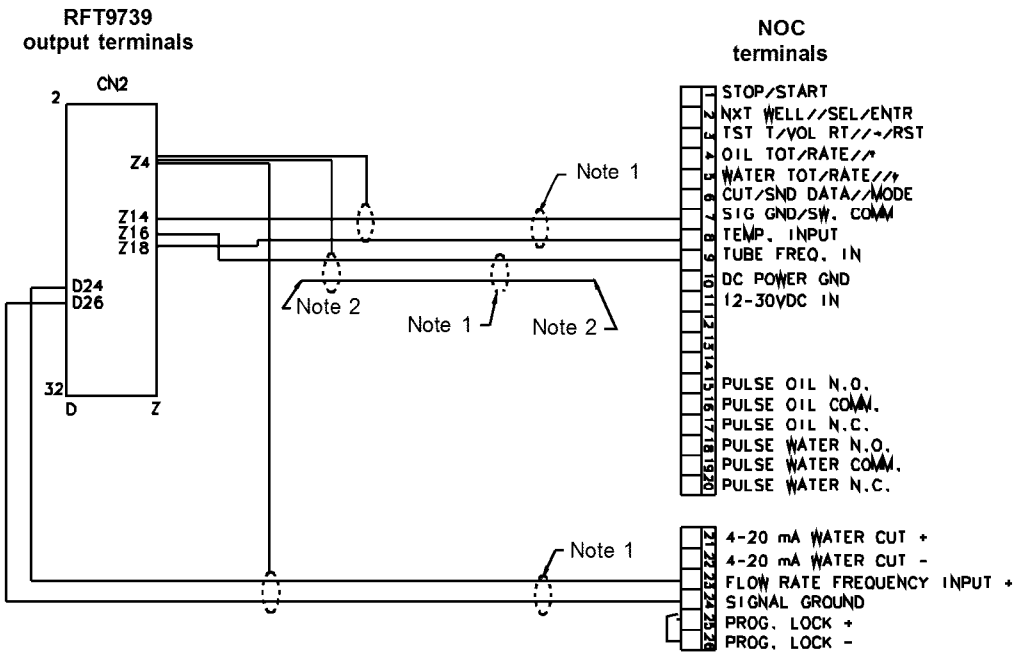

1. Clip shields at this end.
2. This wire not terminated.

Output Wiring continued

Figure 5-25a. Wiring to Model 3300 with screw-type or solder-tail terminals

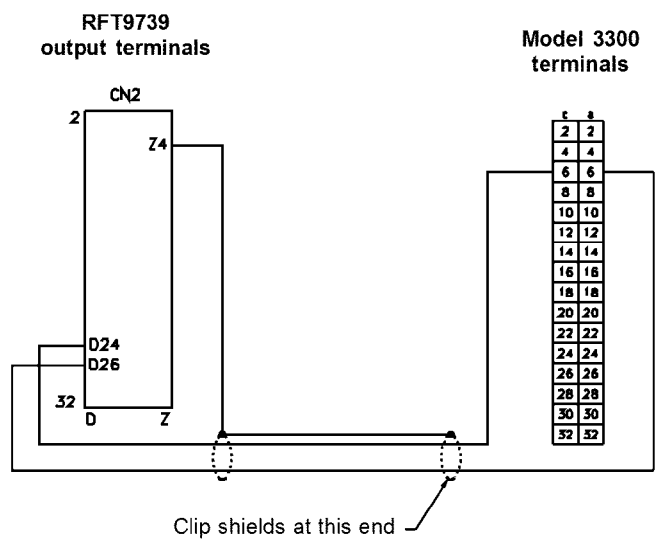

Figure 5-25b. Wiring to Model 3300 with I/O cable

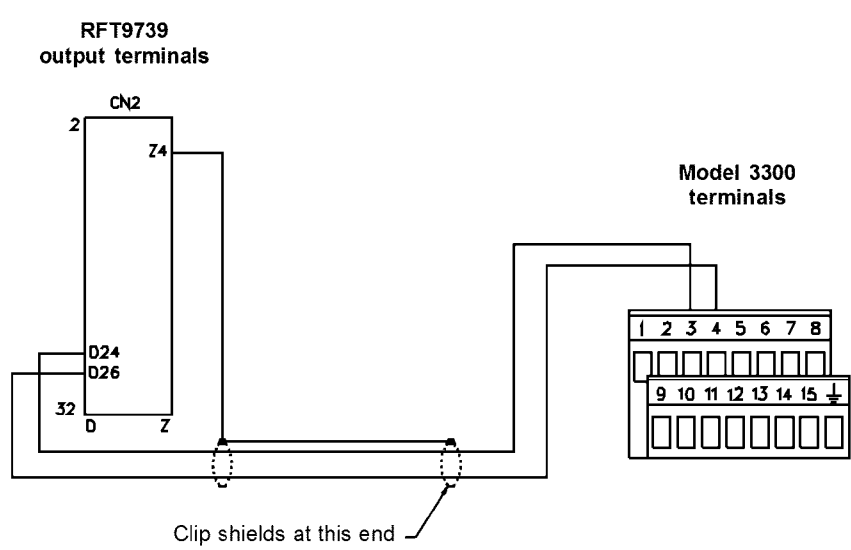
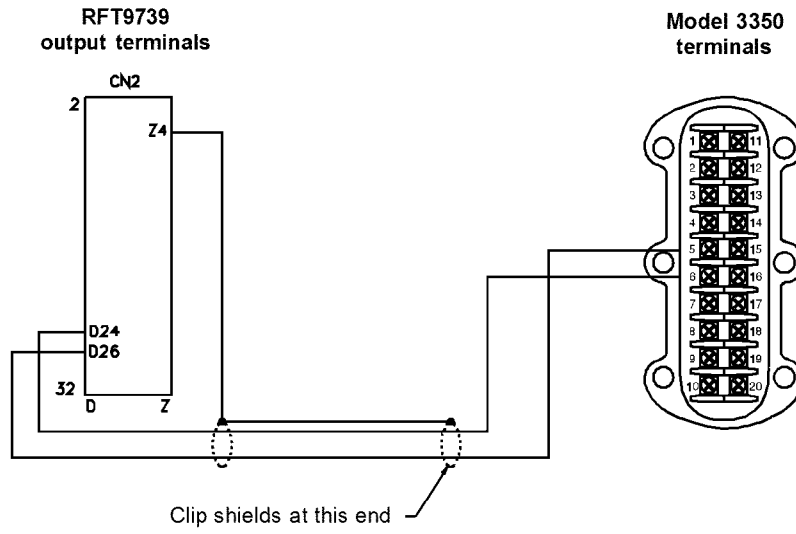

Figure 5-26. Wiring to Model 3350



5.7 Pressure transmitter wiring

**⚠ CAUTION**

**Failure to comply with requirements for intrinsic safety if the sensor is installed in a hazardous area could result in an explosion.**

Pressure transmitter wiring is not intrinsically safe.

Keep pressure transmitter wiring separated from intrinsically safe sensor wiring, power-supply wiring, and any other intrinsically safe wiring.

The RFT9739 accepts pressure input signals from a pressure transmitter for pressure compensation.

- If a pressure transmitter connected to a host controller measures gauge pressure at the sensor input, the RFT9739 can compensate for the pressure effect on the sensor. Pressure compensation is required only for the sensor models listed in **Table 5-3**.
- Instructions for wiring the RFT9739 to a pressure transmitter are provided below. Instructions for configuring the RFT9739 for pressure compensation are provided in the following instruction manuals and in the AMS on-line help:
  - Using the HART Communicator with Micro Motion Transmitters
  - Using ProLink Software with Micro Motion Transmitters
  - Using Modbus Protocol with Micro Motion Transmitters

The RFT9739 pressure input terminals (CN2-Z6 and CN2-Z20) are intended for use with a pressure transmitter, and should not be connected to a control system.

If the RFT9739 is configured for pressure compensation, flowmeter measurement will not be compensated for pressure during a pressure input failure. If the signal from the pressure transmitter fails, both of the following occur:

- The RFT9739 continues to operate in non-fault mode.
- A "Pressure Input Failure" message appears on the transmitter display, a HART Communicator with the latest memory module, ProLink software version 2.4 or higher, or AMS software.

**Table 5-3.  
Sensors affected by  
pressure**

ELITE	F-Series	Model D and DL
CMF025 (density only)	F025 (density only)	D300 standard model
CMF050 (density only)	F050	D300 Tefzel® model
CMF100	F100	D600
CMF200	F200	DL100
CMF300		DL200
CMF400		

If the pressure transmitter requires a power supply less than or equal to 11.75 V, the RFT9739 can power the pressure transmitter. Use RFT9739 terminals CN2-Z6 and CN2-Z20. Terminal Z6 (P) is the power output to the pressure transmitter, and terminal Z20 (S) is the signal input to the RFT9739, as shown in **Figure 5-27a**.

If the pressure transmitter requires a power supply greater than 11.75 V, or if other loop devices are required, an external source can power the pressure transmitter. Use RFT9739 terminals CN2-Z20 and CN2-D14 or CN2-Z14. Terminal Z20 (S) is the signal input to the RFT9739, and terminal D14 or Z14 (SIGNAL GND) is the return, as shown in **Figure 5-27b**, page 53.

If digital communication between the pressure transmitter and the RFT9739 is required, use primary variable terminals CN2-Z30 (PV+) and CN2-D30 (PV-), as shown in **Figure 5-27c**, page 53.

**Figure 5-27a. Wiring to pressure transmitter — analog output**

 **WARNING:** Pressure transmitter wiring is not intrinsically safe

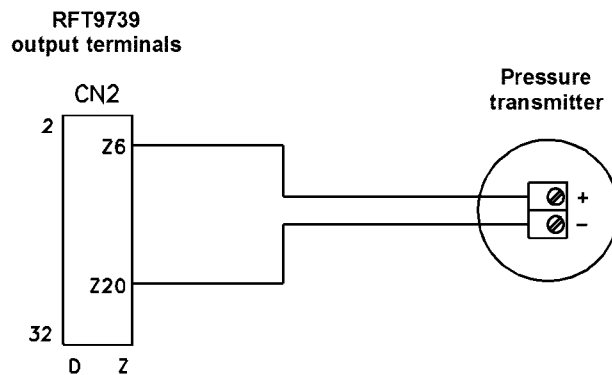

### Output Wiring continued

#### Figure 5-27b. Wiring to pressure transmitter — external power, analog input

**!** WARNING: Pressure transmitter wiring is not intrinsically safe

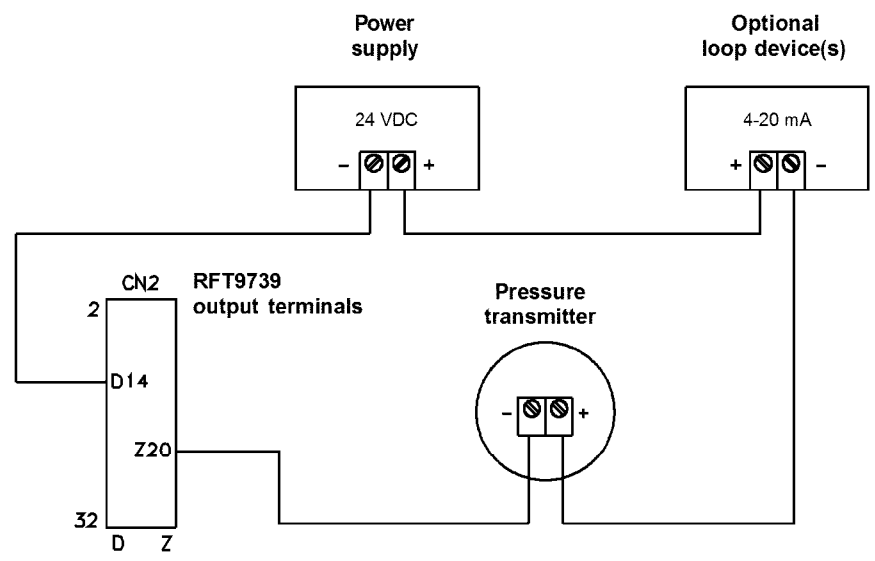

Terminal CN2-D14 must be connected directly to the negative (-) terminal of the external power supply.

#### Figure 5-27c. Wiring to pressure transmitter — digital communications

**!** WARNING: Pressure transmitter wiring is not intrinsically safe

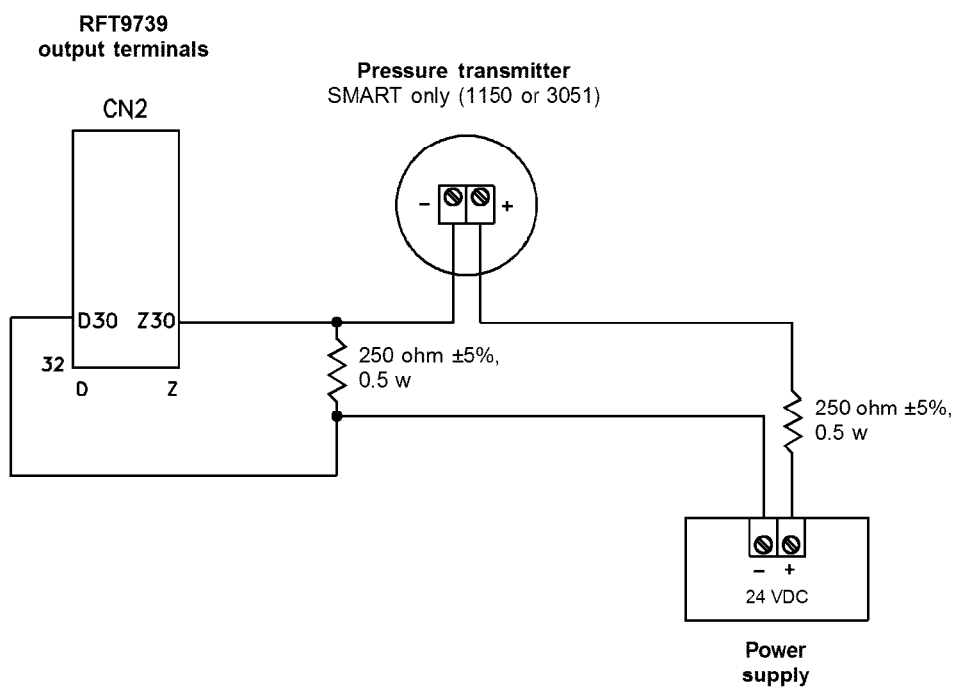

### 5.8 Remote-zero switch

The transmitter can be zeroed from a remote switch. If the transmitter display indicates flow rate, this contact will zero the flowmeter. If the transmitter display indicates flow total, this contact will reset the flow total.

- **Section 6.4**, page 65, describes the flowmeter zeroing procedure.
- **Section 6.5**, page 67, describes the totalizer reset procedure.

The switch must be a momentary-type contact, normally open, close to zero, and must carry 1 mA of current in the closed position. The open circuit voltage is 5 VDC.

Use terminals CN2-D20 and CN2-D26 for the remote switch. Terminal D26 serves as a common return for the external-switch input, frequency/pulse output, dual-channel frequency output, and control output. See **Figure 5-28**.

**Figure 5-28.**  
Wiring to remote-zero switch

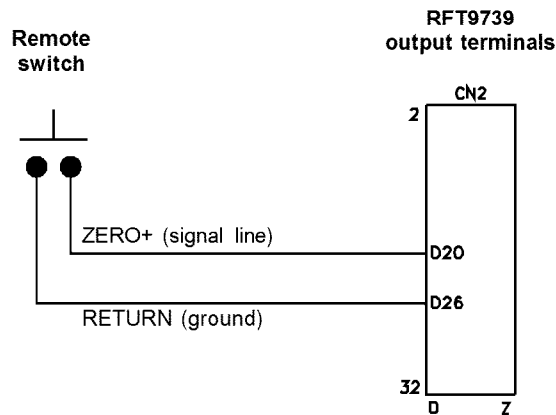



## 5.9 RS-485 multidrop network

The RFT9739 can be configured to communicate for any one of the following options:

- HART protocol over the RS-485 standard
- HART protocol over the Bell 202 standard
- Modbus protocol over the RS-485 standard
- Modbus protocol over the RS-485 standard and HART protocol over the Bell 202 standard

For communications configuration instructions, see "Communication configuration mode," page 61. For Bell 202 network wiring, see **Section 5.10**, page 56.

Multiple transmitters can participate in an RS-485 multidrop network that uses HART or Modbus protocol.

- Under HART protocol, an almost unlimited number of transmitters can participate in the network. Each transmitter must have a unique tag name. If polling addresses are used, up to 16 transmitters can have unique polling addresses from 0 to 15.
- Under Modbus protocol, up to 15 transmitters can participate in the network. Each transmitter must have a unique polling address from 1 to 15.

To connect the transmitter to an RS-485 network, use transmitter terminals CN2-Z22 and CN2-D22. **Figure 5-29**, page 56, shows how to connect one RFT9739 or multiple RFT9739 transmitters to a host controller for RS-485 serial communication.

- Install twisted-pair, shielded cable, consisting of 24-gauge (0.3 mm $\leq$ ) or larger wire, between the RFT9739 and an RS-485 communication device. Maximum cable length is 4000 feet (1200 meters).
- Some installations require a 120-ohm,  $\Omega$ -watt resistor at each end of the network cable to reduce electrical reflections.

For information on communication protocol requirements for implementing an RS-485 network, phone the Micro Motion Customer Service Department:

- In the U.S.A., phone 1-800-522-6277, 24 hours
- Outside the U.S.A., phone 303-530-8400, 24 hours
- In Europe, phone +31 (0) 318 549 443
- In Asia, phone 65-770-8155

Figure 5-29. RS-485 wiring

One RFT9739 and a host controller

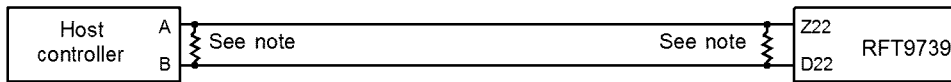

Multiple RFT9739s and a host controller

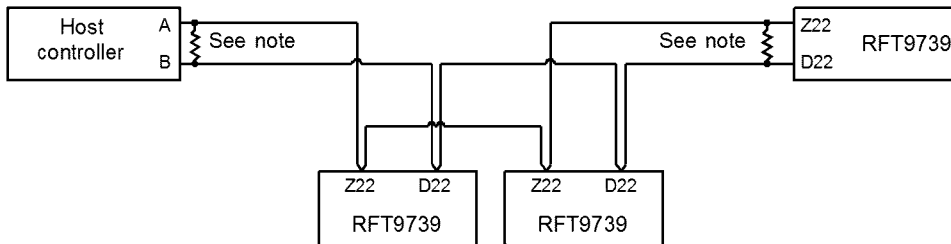

For long-distance communication, or if noise from an external source interferes with the signal, install 120-ohm  $\Omega$ -watt resistors across terminals of both end devices.

### 5.10 Bell 202 multidrop network

The RFT9739 can be configured to communicate for any one of the following options:

- HART protocol over the RS-485 standard
- HART protocol over the Bell 202 standard
- Modbus protocol over the RS-485 standard
- Modbus protocol over the RS-485 standard and HART protocol over the Bell 202 standard

For communications configuration instructions, see "Communication configuration mode," page 61. For RS-485 network wiring, see **Section 5.9**, page 55.

Devices in a Bell 202 multidrop network communicate by sending and receiving signals to and from one another. HART protocol supports up to 15 transmitters in a Bell 202 multidrop network. The actual maximum number depends upon the type of transmitters, the method of installation, and other external factors. Other Rosemount SMART FAMILY transmitters can also participate in a HART-compatible network.

- A Bell 202 multidrop network uses twisted-pair wire, and allows only digital communication. Digital communication requires a sample rate of 2 to 31 seconds at 1200 baud.
- A HART Communicator or other HART-compatible control system can communicate with any device in the network over the same 2-wire pair.

Using multiple transmitters in a HART-compatible network requires assigning a unique address from 1 to 15 to each transmitter.

- Assigning an address of 1 to 15 to the transmitter causes the primary mA output to remain at a constant 4 mA level.
- The primary mA output must produce a 4-20 mA current for the Bell 202 physical layer. The Bell 202 layer will not work with the primary mA output configured as a 0-20 mA output when the current output is 0 mA

## Output Wiring continued

To connect the transmitter to a Bell 202 network, use RFT9739 terminals CN2-Z30 and CN2-D30. See **Figure 5-30**.

- SMART FAMILY devices require a minimum loop resistance of 250 ohms. Loop resistance must not exceed 1000 ohms.
- Connect the mA outputs from each transmitter together so they terminate at a common load resistor, with at least 250 ohms impedance, installed in series.

**Figure 5-30. Typical HART® network wiring**

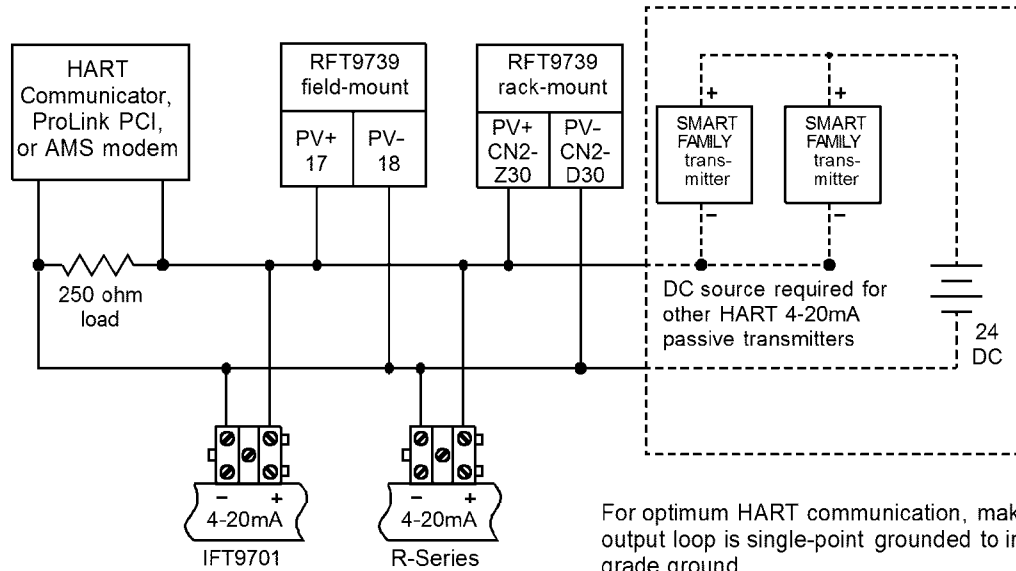

### 5.11 Security wiring

Security wiring enables the use of remote (keyed) switches to disable the front-panel Scroll and Reset buttons.

#### Scroll inhibit

To install a remote (key) switch that disables the front-panel Scroll button, connect a signal line to terminal CN2-D16 (SCROLL INH) and a ground wire to terminal CN2-D14 (SIGNAL GND). See **Figure 5-31**.

#### Reset inhibit

To install a remote (key) switch that disables the front-panel Reset button, connect a signal line to terminal CN2-D18 (ZERO INH) and a ground wire to terminal CN2-D14 (SIGNAL GND). See **Figure 5-31**.

**Figure 5-31.**  
Inhibit-switch wiring

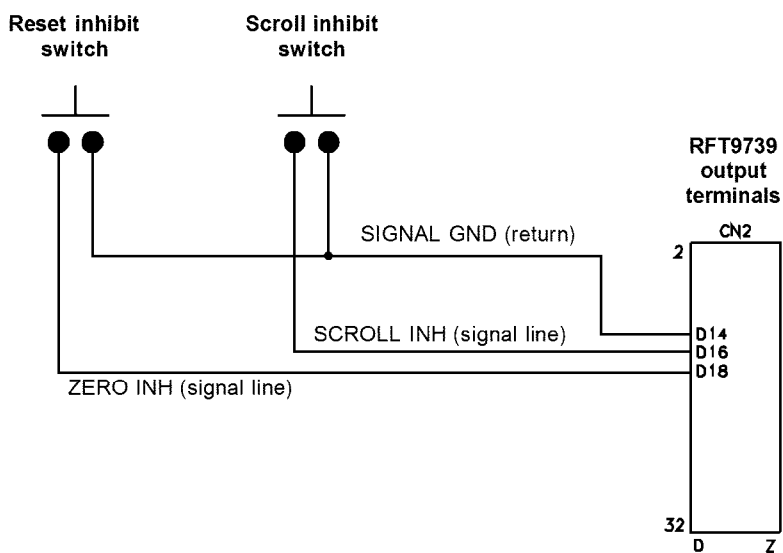

## 6.1 Initialization

After wiring has been connected, power can be supplied to the transmitter. During initialization, the transmitter performs a self-diagnostic test and produces the following series of displays, sequentially:

1. All pixels on
2. All pixels off
3. All eights
4. All pixels off
5. Copyright notification

**For DC-powered transmitters**, at startup, the transmitter power source must provide a minimum of 2 amperes of inrush current at a minimum of 12 volts at the transmitter's power input terminals. If the startup voltage is pulled below 12 VDC, the transmitter could remain in the startup loop indefinitely.

After the self-test is complete, one of 10 possible process variable screens, such as the one depicted below, displays:

INV:	38450.5
GRAMS:	Msg

If the flowmeter is operating properly, the blinking "Msg" (message) indicator appears in the bottom right corner of the screen to indicate power has been cycled.

- To clear the "Msg" indicator, repeatedly press the Scroll button until the display reads "Sensor OK \*POWER / RESET\*".
- To clear the message, press the Scroll button.

If the message does not clear, or if error messages appear, refer to **Section 7.4**, page 73, which provides an overview of diagnostic and error messages.

## 6.2 Using the display

The RFT9739 display enables the user to:

- View process variables, flow totals and inventory levels, and status messages (see page 60)
- Set communication parameters (see page 61)
- Zero the flowmeter (see page 65)
- Reset the transmitter's flow totalizers (see page 67)

Use the Scroll and Reset buttons to operate the display.

### Process variables mode

After power to the transmitter is turned off and on, or "cycled," the transmitter is in the process variables mode. The first screen that appears is the last process variable that was viewed before power was cycled. In the process variables mode, each screen indicates the value and measurement unit for a process variable.

As the user scrolls through the process variable screens, they appear in the order listed in **Table 6-1**.

**Table 6-1.**  
Display screens

Screen	Process variable	Abbreviation in upper left corner of screen
1	Mass flow rate	(RATE)
2	Volume flow rate	(RATE)
3	Density	(DENS)
4	Temperature	(TEMP)
5	Mass total <sup>[1]</sup>	(TOT)
6	Volume total <sup>[1]</sup>	(TOT)
7	Mass inventory <sup>[1]</sup>	(INV)
8	Volume inventory <sup>[1]</sup>	(INV)
9	Differential pressure or gauge pressure <sup>[2]</sup>	(DP) or (P)
10	Configuration event register <sup>[3]</sup>	(CONFIG REG)
11	Calibration event register <sup>[3]</sup>	(CALIBRATE REG)
12	Display test <sup>[3]</sup>	(DISPLAY TEST)
13	Message (if any)	--

<sup>[1]</sup>While reading total (TOT) or inventory (INV) screens, use the unit of measure in the lower left corner to distinguish between mass and volume.

<sup>[2]</sup>Screen appears only when transmitter is configured to indicate pressure.

<sup>[3]</sup>Screen appears only when transmitter is configured for security mode 8. See **Section 2.3**, page 5, for information about security modes.

When displaying total (TOT) or inventory (INV) screens, display resolution is 10 places, including the decimal point. The position of the decimal point is fixed, and depends on the flow calibration factor and units of measure. If totalizers exceed the maximum display capability, the display reads "\*\*\*\*\*". Clear the message with the Reset knob.

If a message exists, the blinking "Msg" (message) indicator appears in the bottom right corner of each screen, indicating any of the following conditions:

- Power to the transmitter has been cycled.
- The flowmeter has been zeroed.
- An error condition exists.

To read a message, scroll past all process variable screens to the message screen (see **Table 6-1**, page 60). Uncorrected status conditions remain in the message queue. Other messages are cleared when the Scroll button is used to scroll past the message screen to the flow rate screen.

If power to the transmitter has been cycled and the transmitter is operating properly, the message reads "Sensor OK \*POWER / RESET\*".

For more information about messages, refer to **Section 7.4**, page 73.

### Communication configuration mode

Switch 5 on the transmitter control board allows the user to select the standard communication configuration or establish a user-defined configuration. See **Section 2.3**, page 5, and "Communication settings", page 9. The communication configuration mode allows the user to configure the transmitter's digital communication output using the display and the Scroll and Reset buttons.

- If switch 5 is in the USER-DEFINED position, enter the communication configuration mode from any process variable screen by pressing and holding the Scroll button and the Reset button at the same time. In the communication configuration mode, the text "M1", "M2", and "M3" will appear in the upper left corner of the screen.
- For RFT9739 software versions 3.6 and later, if switch 5 is in the STD COM position, an error message will be displayed if an attempt is made to change the communication configuration using the Scroll and Reset buttons.

### **M1 - Baud rate**

To set the baud rate:

1. Press and release the Scroll button to view each baud rate option.  
Choose from 1200, 2400, 4800, 9600, 19200, or 38400 baud.
2. Press and hold the Reset button to select the displayed baud rate.  
Release the Reset button when the display stops flashing.
3. When the selected baud rate flashes again, press and release the Reset button to move to the M2 screen.

### **M2 - S=Stop bits, P=Parity**

To set the stop bits and parity:

1. Press and release the Scroll button to view each stop bit (S) option.  
Choose 1 stop bit or 2 stop bits.
2. Press and hold the Reset button to select the displayed stop bit.  
Release the Reset button when the display stops flashing.
3. When the selected stop bit flashes again, press and release the Reset button to move to the parity (P) options.
4. Press and release the Scroll button to view each parity (P) option.  
Choose from odd parity (O), even parity (E), or no parity (N). HART protocol requires odd parity; Modbus protocol requires odd parity, even parity, or no parity, depending on the host controller.
5. Press and hold the Reset button to select the displayed parity.  
Release the Reset button when the display stops flashing.
6. When the selected parity flashes again, press the Reset button to move to the M3 screen.



**M3 - Data bits and protocol**

The M3 screen enables selection of 7-bit or 8-bit mode for Modbus protocol, or 8-bit mode for HART protocol.

- The HART protocol can use either the Bell 202 or RS-485 physical layer.
- Using HART protocol over the primary mA output requires the Bell 202 physical layer.

**⚠ CAUTION**

**Changing the protocol will cause the transmitter to restart, which could result in switching of flow loop control devices.**

Set control devices for manual operation before changing the communications protocol.

To set the data bits and protocol:

1. Press and release the Scroll button to view each data bits (D) option. Choose from 7 data bits or 8 data bits. HART protocol requires 8 data bits; Modbus protocol requires 7 data bits for ASCII mode or 8 data bits for RTU mode.
2. Press and hold the Reset button to select the displayed data bits. Release the Reset button when the display stops flashing.
3. When the selected data bits flashes again, press and release the Reset button to move to the protocol and physical layer options.
4. Press and release the Scroll button to view each protocol/physical layer option. Choose from the following:
  - HART protocol over the Bell 202 physical layer (HART/202)
  - HART protocol over the RS 485 physical layer (HART/485)
  - Modbus protocol over the RS-485 physical layer (Modbus/485)
  - Modbus protocol over the RS-485 physical layer and HART protocol over the Bell 202 physical layer (Modbus/202)
5. Press and hold the Reset button to select the displayed protocol/physical layer. Release the Reset button when the display stops flashing.
6. When the selected protocol/physical layer flashes again, press and release the Reset button to restart the transmitter. If the protocol/physical layer was not changed, the transmitter will not restart, and the display will return to the process variable screen.

**6.3 Custody transfer event registers**

Event registers are provided for security requirements for custody transfer applications. When the transmitter is configured for security mode 8 (see **Section 2.3**, page 5), the transmitter meets security requirements for custody transfer described in National Institute of Standards and Technology (NIST) Handbook 44.

Custody transfer event registers record one change for each change "session." A change session begins when the transmitter is taken out of security mode 8, and ends when security mode 8 is reentered. To begin a change session, set switches 1, 2, and 3 to the OFF position. A change session ends when switches 1, 2, and 3 are reset to the ON position. After a change session ends, security event registers will increase by one (1) if any of the parameters listed in **Table 6-2** have been changed.

- Each register will increase up to 999, then roll over to zero.
- Custody transfer event registers cannot be reset.

View the security event registers using any of the following methods:

- With the RFT9739 display. If the transmitter has a display, event registers can be viewed from the CONFIG REG and CALIBRATE REG screens when the transmitter is configured for security mode 8.
- With ProLink software version 2.3 or higher. Refer to on-line help for instructions.
- With AMS software. Refer to on-line help for instructions.
- With a HART Communicator.
- With a HART-compatible or Modbus-compatible master controller.

**Table 6-2.  
Parameters that affect event registers**

<b>Configuration register</b>	
Mass flow cutoff	Primary mA output trim
Flow damping	Secondary mA output trim
Volume flow cutoff	Primary mA output assignment
Flow direction	Secondary mA output assignment
Primary mA scaling factors	Control output assignment
Secondary mA scaling factors	Master reset
<b>Calibration register</b>	
Mass flow units	Density calibration factors
Volume flow units	• Density A and Density B
Auto zero calibration	• K1, K2, and FD
Density calibration	• Density temperature coefficient
Flow calibration factor	Pressure compensation factors
Meter factors	• Flow factor
Frequency output scaling factors	• Density factor
• Frequency	• Flow calibration pressure
• Rate	

## 6.4 Flowmeter zeroing

### ⚠ CAUTION

Failure to zero the flowmeter at initial startup could cause measurement error.

Zero the flowmeter before putting it in operation.

Flowmeter zeroing establishes flowmeter response to zero flow and sets a baseline for flow measurement.

### Zeroing procedure

To zero the transmitter, follow these steps:

1. Prepare the flowmeter for zeroing:
  - a. Install the sensor according to the sensor instruction manual.
  - b. Apply power to the transmitter, then allow it to warm up for at least 30 minutes.
  - c. Ensure the transmitter is in a security mode that allows flowmeter zeroing. See "Security modes", page 6.
  - d. Run the process fluid to be measured through the sensor until the sensor temperature reading approximates the normal process operating temperature.
2. Close the shutoff valve downstream from the sensor.
3. Ensure zero flow through the sensor.

### ⚠ CAUTION

Flow through the sensor during flowmeter zeroing will result in an inaccurate zero setting.

Make sure the sensor tubes are **completely** full and fluid flow through the sensor is **completely** stopped during flowmeter zeroing.

4. Zero the transmitter in any of four ways:
  - Press and hold the Reset button for at least ten seconds. (In the rate screens, "RATE" appears in the upper left corner of the screen.)
  - An external contact closure can be used for transmitter zeroing. (Refer to **Section 5.8**, page 54, for wiring instructions). Close the contact for at least ten seconds.
  - Issue an auto zero command using a HART Communicator, a HART-compatible or Modbus-compatible master controller, or the ProLink program.
  - Issue a "zero trim" command with the AMS program.

During the zeroing procedure, the display reads "Sensor OK CAL IN PROGRESS". The default zero time will range from 20 to 90 seconds, depending on the sensor.

After flowmeter zeroing has been completed, the mass flow rate or volume flow rate screen reappears, and the blinking "Msg" (message) indicator appears in the lower right corner. To clear the message indicator, scroll past the volume inventory screen to the message screen, which should read "Sensor OK \*ERROR CLEARED\*".

**Diagnosing zero failure**

If zeroing fails, the blinking "Msg" (message) indicator appears. The message screen will indicate the zero failure with a message such as "\*\*ZERO ERROR\*\*", "\*\*ZERO TOO HIGH\*\*", or "\*\*ZERO TOO LOW\*\*". An error condition could indicate:

- Flow of fluid during flowmeter zeroing
- Partially empty flow tubes
- An improperly mounted sensor

To clear a zeroing error, cycle power to the transmitter, ensure that the sensor flow tubes are filled with fluid and flow is stopped, then re-zero the flowmeter again.

**Additional information about flowmeter zeroing**

Flowmeter zeroing can be disabled using the transmitter's security modes or with a remote (keyed) switch that disables the RFT9739 Reset button.

- **Table 6-1** describes how RFT9739 security modes 1 through 8 affect flowmeter zeroing. Refer to **Section 2.3**, page 5, for more information about security modes.
- **Section 5.11**, page 58, describes how to install keyed switches to disable the front-panel Reset button.

The transmitter has a programmable zeroing time (number of measurement cycles), and enables the user to set the standard deviation limits. For more information, see any of the following instruction manuals:

- Using the HART Communicator with Micro Motion Transmitters
- Using ProLink Software with Micro Motion Transmitters
- Using Modbus Protocol with Micro Motion Transmitters

**Table 6-1. Effect of security modes on flowmeter zeroing**

Performed with	Mode 1	Mode 2	Mode 3	Mode 4	Mode 5	Mode 6	Mode 7	Mode 8
Reset button		Disabled	Disabled	Disabled	Disabled	Disabled	Disabled	Disabled
HART or Modbus device			Disabled	Disabled	Disabled			Disabled

## 6.5 Totalizer control

The transmitter's mass totalizer and volume totalizer can be started, stopped, and reset using any of the following:

- A HART Communicator
- ProLink software version 2.4 or higher
- A Modbus device
- A M S s o f t w a r e

In addition, the totalizer can be reset from the RFT9739 front panel.

**⚠ WARNING**

**When the totalizers are stopped, the frequency/pulse output is disabled.**

If the frequency/pulse output is used for process control, failure to set control devices for manual operation could affect process control.

- Before stopping the totalizers, set process control devices for manual operation.
- To enable the frequency/pulse output, restart the totalizers.

Totalizer functions can be disabled using the transmitter's security modes or with a remote (keyed) switch.

- **Table 6-2**, page 68, lists the totalizer functions that are disabled with RFT9739 security modes 1 through 8. Refer to **Section 2.3**, page 5, for more information about security modes.
- **Section 5.11**, page 58, describes how to install keyed switches to disable the front-panel Scroll and Reset buttons.

Mass and volume totalizers cannot be reset independently. When one totalizer is reset, the other is also reset. Resetting the totalizer has no effect on the mass or volume inventory. To reset the transmitter's mass totalizer and volume totalizer using the RFT9739 Scroll and Reset buttons:

1. Use the Scroll button to view the process variable screens until either totalizer screen appears. (In the totalizer screens, "TOT" appears in the upper left corner.)
2. Hold the Reset button until the screen turns blank, then release.

Startup continued

**Table 6-2. Effect of security modes on totalizer control**

Flow condition	Performed with	Mode 1	Mode 2	Mode 3	Mode 4	Mode 5	Mode 6	Mode 7	Mode 8
No flow	Scroll and Reset buttons		Disabled		Disabled	Disabled		Disabled	
	HART or Modbus device			Disabled		Disabled	Disabled		
With flow	Scroll and Reset buttons		Disabled	Disabled	Disabled	Disabled	Disabled	Disabled	Disabled
	HART or Modbus device			Disabled	Disabled	Disabled	Disabled	Disabled	Disabled

Resetting the totalizer has no effect on the mass or volume inventory.  
 For more information about security modes, refer to **Section 2.3**, page 5.

**6.6 Process measurement**

After flowmeter zeroing has been completed as described in **Section 6.4**, page 65, the flowmeter is ready for process measurement.

## 7.1 General guidelines

Troubleshooting a Micro Motion flowmeter is performed in two parts:

1. Tests of wiring integrity
2. Observation of the transmitter's diagnostic tools, which include diagnostic messages and fault output levels.

### CAUTION

**During troubleshooting, the transmitter could produce inaccurate flow signals.**

Set control devices for manual operation while troubleshooting the flowmeter.

Follow these general guidelines when troubleshooting a Micro Motion flowmeter:

- Before beginning the diagnostic process, become familiar with this instruction manual and with the instruction manual for the sensor.
- While troubleshooting a problem, leave the sensor in place, if possible. Problems can result from the specific environment in which the sensor operates.
- Check all signals under both flow and no-flow conditions. This procedure will minimize the possibility of overlooking some causes or symptoms.

## 7.2 Transmitter diagnostic tools

In some situations, troubleshooting requires use of the transmitter's diagnostic tools, which include fault output levels and diagnostic messages.

### Fault outputs

The RFT9739 has downscale and upscale fault outputs. (See "Milliamp output scaling", page 9.) Fault output levels are listed in **Table 7-1**.

**Table 7-1. Fault output levels**

Output	Operating condition	Downscale	Upscale
0-20 mA	Alarm	0 mA	22 mA
	EPROM, RAM, or RTI error; transmitter failure	0 mA	24 mA
4-20 mA	Alarm	2 mA	22 mA
	EPROM, RAM, or RTI error; transmitter failure	0 mA	24 mA
Frequency/pulse	Alarm	0 Hz	15 kHz
	EPROM, RAM, or RTI error; transmitter failure	0 Hz	19 kHz

### Diagnostic messages

The transmitter provides diagnostic messages, which can be viewed on the display of a HART Communicator, or in the Status window of the ProLink software program. Messages are described in the following instruction manuals, and in AMS on-line help:

- Using the HART Communicator with Micro Motion Transmitters
- Using ProLink Software with Micro Motion Transmitters
- Using Modbus Protocol with Micro Motion Transmitters

Use a HART Communicator with the latest memory module, a Modbus host controller, or ProLink software version 2.3 or higher to view the following parameters:

- Drive gain
- Tube frequency
- Left and right pickoff voltages
- "Live zero"

Many of the messages that can be read with a HART Communicator, the ProLink program, or AMS software can be read from the transmitter display. These messages are described in **Section 7.4**, page 73. Modbus host controllers use status bits as diagnostic messages.

In the event of a display readback failure, if the error does not clear itself within 60 seconds, cycle power to the transmitter (turn power OFF, then ON).

### 7.3 Interrogation with a HART® device

Connect a HART device to the communications socket on the transmitter front panel (the socket is labeled "HART"), or use the ProLink program to communicate with the transmitter.

- If the HART Communicator does not offer RFT9739 "Device 4" as a device description, the communicator memory module might need to be upgraded.
- Use ProLink software version 2.3 or higher.
- Use AMS software.
- Contact the Micro Motion Customer Service Department to upgrade your HART Communicator or ProLink program:
  - In the U.S.A., phone 1-800-522-6277
  - Outside the U.S.A., phone 303-530-8400
  - In Europe, phone +31 (0) 318 549 443
  - In Asia, phone 65-770-8155

**Figure 7-1**, page 71, explains how to connect a HART Communicator, the ProLink PC Interface adaptor, or AMS serial modem to the RFT9739. For more information, see the HART Communicator or ProLink software instruction manual, or AMS on-line help.



## Troubleshooting continued

Figure 7-1. HART® Communicator, ProLink® PC-Interface, and AMS modem connections

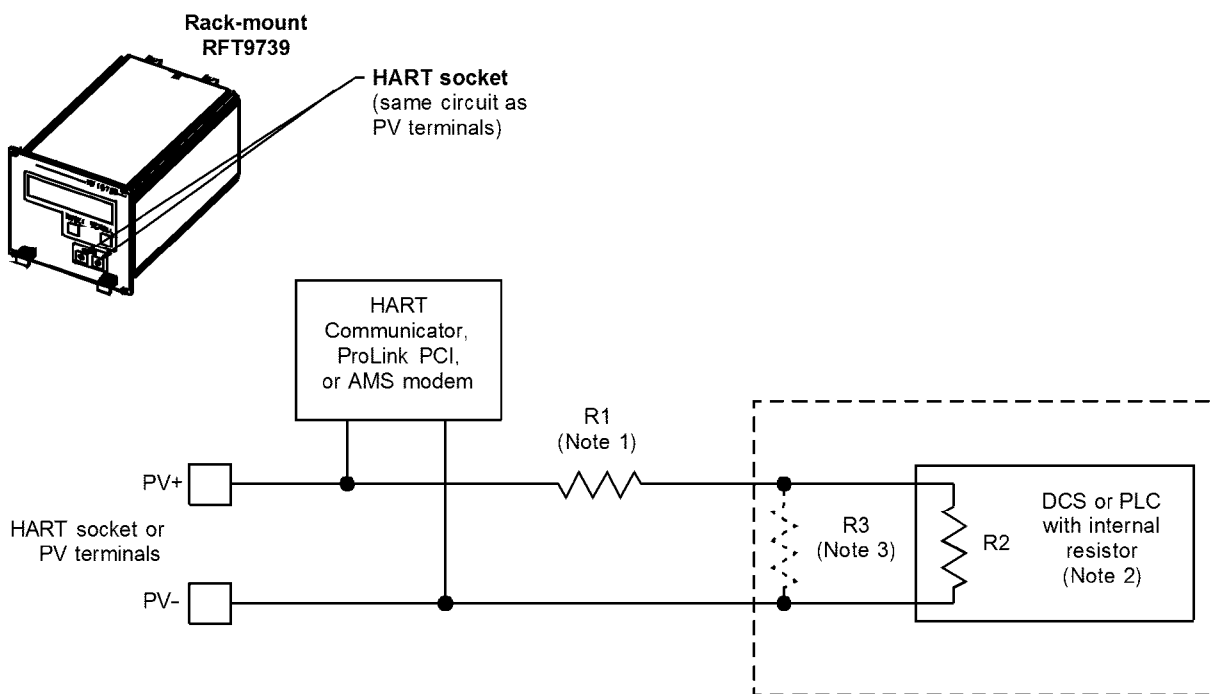

1. If necessary, add resistance in the loop by installing resistor R1. SMART FAMILY® devices require a minimum loop resistance of 250 ohms. Loop resistance must not exceed 1000 ohms, regardless of the communication setup.

### ⚠ CAUTION

Connecting a HART device to the RFT9739 primary variable milliamp output loop could cause transmitter output error.

If the primary variable (PV) analog output is being used for flow control, connecting a HART device to the output loop could cause the transmitter 4-20 mA output to change, which would affect flow control devices.

Set control devices for manual operation before connecting a HART device to the RFT9739 primary variable milliamp output loop.

2. The DCS or PLC must be configured for an active milliamp signal.
3. Resistor R3 is required if the DCS or PLC does not have an internal resistor.

Fault detection indicates an interruption in the functional integrity of the sensor and the transmitter, including the sensor pickoff coils, drive coil, and RTD. Faults, such as a short or an open circuit, are detected by the HART device.

The transmitter runs continuous self-diagnostics. If these diagnostics reveal a failure, the HART device displays an error message. Self-testing allows the transmitter to check its own circuitry.

The transmitter works with a Micro Motion flow sensor to provide flow information. Therefore, many of the troubleshooting checks pertain only to the sensor. However, a HART Communicator, the ProLink program, and AMS software enable the user to perform other tests:

- Performing an mA output test forces the transmitter to produce a user-specified current output of 0 to 22 mA.
- Performing a frequency/pulse output test forces the transmitter to produce a user-specified frequency output between 0.1 and 15,000 Hz.
- Performing an mA output trim allows adjustment of the primary and secondary mA outputs against a highly accurate external standard such as a digital multimeter (DMM) or receiving device.

Perform mA trim and/or test procedures, if necessary, as described in the HART Communicator or ProLink software instruction manuals, or in AMS on-line help.

- If the transmitter is in security mode 8, mA output test, mA output trim, and frequency/pulse output test procedures cannot be performed. For more information, see "Security mode 8", page 7.
- If the transmitter is in fault condition, an mA output test cannot be performed.
- If the transmitter is not properly connected to a sensor, or if the sensor is in fault condition, an mA output test cannot be performed.

## Troubleshooting continued

### 7.4 Troubleshooting using the transmitter display

Using the message screen, refer to the following sections to troubleshoot:

- Overrange and sensor error messages
- Transmitter failure messages
- Slug flow and output saturated messages
- Informational messages

#### Not configured

After the user performs a master reset, the message display reads "NOT CONFIGURED", indicating the flowmeter requires complete characterization and reconfiguration. Use a HART Communicator or the ProLink program to configure the transmitter. To perform a master reset, see **Section 7.7**, page 79.

#### Transmitter failure messages

If a transmitter failure occurs, the display produces one of the following messages:

- "Xmtr Failed"
- "(E)eprom Error"
- "RAM Error"
- "RTError"

If a transmitter failure occurs, contact the Micro Motion Customer Service Department. **Table 7-2** describes transmitter failure messages.

### **⚠ CAUTION**

**Transmitter failures are critical, and could cause unintentional switching of process control devices.**

The transmitter does not have any parts that are serviceable by the user. If a transmitter failure is indicated, phone the Micro Motion Customer Service Department:

- In the U.S.A., phone 1-800-522-6277, 24 hours
- Outside the U.S.A., phone 303-530-8400, 24 hours
- In Europe, phone +31 (0) 318 549 443
- In Asia, phone 65-770-8155

**Table 7-2. Using transmitter failure messages**

Message	Condition	Corrective action
Xmtr Failed	Transmitter hardware failure	Phone the Micro Motion Customer Service Department:
(E)EPROM error	EPROM checksum failure	• In the U.S.A., phone 1-800-522-6277, 24 hours
RAM Error	RAM diagnostic failure	• Outside the U.S.A., phone 303-530-8400, 24 hours
RTI Error	Real-time interrupt failure	• In Europe, phone +31 (0) 318 549 443
		• In Asia, phone 65-770-8155

### Overrange and sensor error messages

If a sensor failure occurs, if the sensor cable is faulty, or if measured flow, measured temperature, or measured density go outside the sensor limits, the display produces one of the following messages:

- "Sensor Error"
- "Drive Overrng"
- "Input Overrange"
- "Temp Overrange"
- "Dens Overrng"

To interpret overrange and sensor error messages, use the transmitter fault output levels, a digital multimeter (DMM) or other reference device, and refer to **Table 7-3**, page 75, for corrective actions.

- Turn off power to the transmitter before unplugging terminal blocks.
- Unplug terminal blocks from the transmitter back panel to check circuits.

### Slug flow

Programmed slug flow limits enable transmitter outputs and the display to indicate conditions such as slug flow (gas slugs in a liquid flow stream). Such conditions adversely affect sensor performance by causing erratic vibration of the flow tubes, which in turn causes the transmitter to produce inaccurate flow signals.

If the user programs slug limits, a slug flow condition causes the following to occur:

1. The message display reads "SLUG FLOW".
2. The frequency/pulse output goes to 0 Hz.
3. The mA outputs indicating the flow rate go to the level that represents zero flow.

The flowmeter resumes normal operation when liquid fills the flow tubes and density stabilizes within the programmed slug flow limits.

The user can also program a slug duration, from 0 to 60 seconds, into the configuration of an RFT9739. If process density goes outside a slug flow limit, flow outputs hold their last measured value for the period of time established as the slug duration.

**Table 7-4**, page 75 summarizes possible slug flow errors and lists typical corrective actions.

### Output saturated messages

If an output variable exceeds its upper range limit, the display message reads "Freq Overrange", "mA 1 Saturated" or "mA 2 Saturated". The message can mean the output variable has exceeded appropriate limits for the process, or can mean the user needs to change measurement units.

**Table 7-4**, page 75 summarizes possible output saturated messages and lists typical corrective actions.

## Troubleshooting continued

**Table 7-3. Using overrange and sensor error messages**
**Instructions**

1. Turn off power to transmitter.
2. Unplug terminal blocks from transmitter back panel to check circuits.

Message	Other symptoms	Cause(s)	Corrective action(s)
Drive Overrng or Input Overrange	<ul style="list-style-type: none"> <li>• Transmitter produces fault outputs</li> <li>• At the transmitter, DMM indicates open or short circuit from red wire to brown wire</li> <li>• At the sensor, DMM indicates open or short circuit from red wire to brown wire</li> </ul>	<ul style="list-style-type: none"> <li>• Flow rate outside sensor limit</li> <li>• Faulty cable</li> <li>• Open or short drive coil in sensor</li> </ul>	<ul style="list-style-type: none"> <li>• Fill sensor with process fluid</li> <li>• Bring flow rate within sensor limit</li> <li>• Monitor flow rate</li> <li>• If open or short at transmitter, reconnect wiring or repair cable</li> <li>• If open or short at sensor, return sensor to Micro Motion</li> </ul>
	<ul style="list-style-type: none"> <li>• Transmitter produces fault outputs</li> <li>• At the transmitter, DMM indicates open or short circuit from green wire to white wire</li> <li>• At the sensor, DMM indicates open or short circuit from green wire to white wire</li> </ul>	<ul style="list-style-type: none"> <li>• Flow rate outside sensor limit</li> <li>• Faulty cable</li> <li>• Open or short left pickoff in sensor</li> </ul>	
Sensor Error	<ul style="list-style-type: none"> <li>• Transmitter produces fault outputs</li> <li>• At the transmitter, DMM indicates open or short circuit from blue wire to gray wire</li> <li>• At the sensor, DMM indicates open or short circuit from blue wire to gray wire</li> </ul>	<ul style="list-style-type: none"> <li>• Faulty cable</li> <li>• Open or short right pickoff in sensor</li> </ul>	<ul style="list-style-type: none"> <li>• If open or short at transmitter, reconnect wiring or repair cable</li> <li>• If open or short at sensor, return sensor to Micro Motion</li> </ul>
	Transmitter produces fault outputs	Moisture in sensor case	<ul style="list-style-type: none"> <li>• Replace conduit and/or conduit seals</li> <li>• Repair cable</li> <li>• Return sensor to Micro Motion</li> </ul>
Drive Overrng or Dens Overrng	Transmitter produces fault outputs	<ul style="list-style-type: none"> <li>• Inappropriate density factors</li> <li>• Process density &gt; 5.0000 g/cc</li> <li>• Severely erratic or complete cessation of flow tube vibration due to gas slugs or solids in process fluid</li> <li>• Plugged flow tube</li> </ul>	<ul style="list-style-type: none"> <li>• Calibrate for density</li> <li>• Correct density factors</li> <li>• Monitor density</li> <li>• Bring density within sensor limit</li> <li>• Purge flow tubes with steam, water, or purging chemical</li> </ul>
Temp Overrange	<ul style="list-style-type: none"> <li>• Transmitter produces fault outputs</li> <li>• At the transmitter, DMM indicates open or short circuit from yellow wire to orange wire</li> <li>• At the sensor, DMM indicates open or short circuit from yellow wire to orange wire</li> <li>• Transmitter produces fault outputs</li> <li>• At the transmitter, DMM indicates open or short circuit from violet wire to yellow wire</li> <li>• At the sensor, DMM indicates open or short circuit from violet wire to yellow wire</li> </ul>	<ul style="list-style-type: none"> <li>• Temperature outside sensor limit</li> <li>• Faulty cable</li> <li>• Open or short lead length compensator</li> <li>• Faulty cable</li> <li>• Open or short RTD in sensor</li> </ul>	<ul style="list-style-type: none"> <li>• Bring temperature within sensor limit</li> <li>• Monitor temperature</li> <li>• If open or short at transmitter, reconnect wiring or repair cable</li> <li>• If open or short at sensor, return sensor to Micro Motion</li> </ul>

**Table 7-4. Using slug flow and output saturated messages**

Message	Condition	Corrective action(s)
Slug flow	<ul style="list-style-type: none"> <li>• Gas slugs causing process density to go below low slug flow limit</li> <li>• Solids causing process density to go above high slug flow limit</li> </ul>	<ul style="list-style-type: none"> <li>• Monitor density</li> <li>• Enter new slug flow limits</li> <li>• Enter new slug duration</li> </ul>
Freq overrange	Flow rate driving output from terminals CN2-D24 (FREQ) and CN2-D26 (RETURN) to 0 or 15 kHz	<ul style="list-style-type: none"> <li>• Change flow measurement units</li> <li>• Rescale frequency/pulse output</li> <li>• Reduce flow rate</li> </ul>
mA 1 saturated	Output from terminals CN2-Z30 (PV+) and CN2-D30 (PV-) equals 0, 3.8, or 20.5 mA	<ul style="list-style-type: none"> <li>• Change value of variable at 20 mA</li> <li>• Alter fluid process</li> </ul>
mA 2 saturated	Output from terminals CN2-Z28 (SV+) and CN2-D28 (SV-) equals 0, 3.8, or 20.5 mA	

## Informational messages

Information messages are described below. **Table 7-5**, page 77, summarizes informational messages and lists typical corrective actions.

**Power Reset** indicates a power failure, brownout, or power cycle has interrupted operation of the transmitter. The transmitter has a nonvolatile memory, which remains intact despite power interruptions.

**Cal in Progress** indicates flowmeter zeroing in progress or density calibration in progress.

**Zero Too Noisy** indicates mechanical noise has prevented the transmitter from setting an accurate zero flow offset during transmitter zeroing.

**Zero Too High** or **Zero Too Low** indicates flow was not completely shut off during sensor zeroing, so the transmitter has calculated a zero flow offset that is too great to allow accurate flow measurement. Zero Too Low indicates the zero flow offset is negative.

**Burst Mode** indicates the user has configured the transmitter to send data in burst mode while operating under HART protocol. In burst mode, the transmitter bursts data at regular intervals.

**mA 1 Fixed** or **mA 2 Fixed** indicates one of several conditions:

- The mA output trim or test was not completed. The output remains fixed at the assigned level until the user completes the output trim or test procedure.
- The user has assigned a polling address other than 0 to the transmitter for Bell 202 communication. The output remains fixed at 4 mA until the user assigns a polling address of 0 to the transmitter.

**Event 1 On** or **Event 2 On** switches ON if an event tied to an RFT9739 output switches the output ON.

- With mass or volume total assigned to the event, the event switches ON and OFF according to the low or high configuration of the alarm. With a LOW alarm, the event switches ON when the user resets the totalizer. With a HIGH alarm, the event switches OFF when the user resets the totalizer.
- With flow, density, temperature, or pressure assigned to the event, the event switches OFF or ON whenever the process variable crosses the setpoint.

**Security Breach** indicates the transmitter security mode has been changed from security mode 8. Clear the message by reentering security mode 8 or by performing a master reset.

**Error Cleared** indicates a previous message has been cleared.

## Troubleshooting continued

**Table 7-5. Using informational messages**

Message	Condition	Corrective action(s)
Power Reset	<ul style="list-style-type: none"> <li>Power failure</li> <li>Brownout</li> <li>Power cycling</li> </ul>	Check accuracy of totalizers
Cal in Progress	<ul style="list-style-type: none"> <li>Flowmeter zeroing in progress</li> <li>Density calibration in progress</li> </ul>	<ul style="list-style-type: none"> <li>If Cal in Progress disappears, no action</li> <li>If Cal in Progress reappears after zeroing or calibration is completed:               <ul style="list-style-type: none"> <li>Check flowmeter cable</li> <li>Eliminate noise, then rezero or recalibrate</li> </ul> </li> </ul>
Zero Too Noisy	Mechanical noise prevented accurate zero flow setting during auto zero	Eliminate mechanical noise, if possible, then rezero
Zero Too High	Flow not completely shut off during auto zero	Completely shut off flow, then rezero
Zero Too Low	Moisture in sensor junction box caused zero drift	Ensure interior of junction box is completely dry, then rezero
Burst Mode	Transmitter configured to send data in burst mode under HART protocol	Switch burst mode OFF
mA 1 Fixed	Communication failure during test or trim of mA output from terminals CN2-Z30 (PV+) and CN2-D30 (PV-) Polling address of 1 to 15 assigned to RFT9739 for HART in Bell 202	Complete trim or test <ul style="list-style-type: none"> <li>Change polling address to zero (0)</li> <li>Use RS-485 communication standard</li> </ul>
mA 2 Fixed	Communication failure during test or trim of output from terminals CN2-Z28 (SV+) and CN2-D28 (SV-)	Complete trim or test
Event 1 On	Event (alarm) 1 is ON	<ul style="list-style-type: none"> <li>If totalizer assigned:               <ul style="list-style-type: none"> <li>Low alarm switches event ON at totalizer reset</li> <li>High alarm switches event OFF at totalizer reset</li> </ul> </li> <li>If other variable assigned, event switches ON/OFF when variable crosses setpoint</li> </ul>
Event 2 On	Event (alarm) 2 is ON	
Security Breach	Security mode changed from mode 8	<ul style="list-style-type: none"> <li>Re-enter security mode 8</li> <li>Perform master reset</li> </ul>

### 7.5 Power supply

The transmitter is configured at the factory for a 110/115 VAC or 220/230 VAC power supply. All RFT9739 rack-mount transmitters can accept a 12 to 30 VDC power supply, independent of the AC power-supply configuration.

- A label on the upper corner of the transmitter back panel indicates the configured power-supply voltage.
- The AC power supply voltage configuration can be changed by the user. See **Section 4.3**, page 21.

Check for specified power at the transmitter terminals.

- Wire DC power at connector CN2, to terminals Z32 (DC+) and D32 (DC-).
- Wire AC power at connector CN3 and the ground lug above connector CN3.
- Some European applications require installation of AC power-supply wiring to connector CN2, terminals D2 (AC+), D6 (AC-), and Z2 (GND). **In Europe, before making AC power-supply wiring connections at CN2**, contact the Micro Motion Customer Service Department. In Europe, phone +31 (0) 318 549 443.
- If the transmitter is wired for an AC power supply, ensure switch S1 on the power board is in the appropriate position. See **Section 4.3**, page 21.
- Check fuses. See "Fuses", page 21.

## 7.6 Wiring

For transmitter wiring instructions, refer to **Chapter 4**, page 17, and **Chapter 5**, page 25. Wiring problems are often incorrectly diagnosed as a faulty sensor. At initial startup of the transmitter, always check the following:

1. Proper cable, and use of shielded pairs
2. Proper wire termination
  - a. Wires on correct terminals
  - b. Wires making good connections at transmitter terminals
  - c. Wires making good connections at the sensor terminals
  - d. Wires properly connected at any intermediate terminal junction, such as the user-supplied junction box between a Model DT sensor and transmitter.

If a fault condition is indicated, follow these instructions:

1. Disconnect the transmitter's power supply.
2. Unplug the terminal blocks from the transmitter back panel.
3. Use a digital multimeter (DMM) to measure resistance between wire pairs at the transmitter terminals:
  - Drive coil, check terminals CN1-Z2 and CN1-B2 (brown/red)
  - Left pickoff coil, check terminals CN1-Z8 and CN1-B8 (green/white)
  - Right pickoff coil, check terminals CN1-Z10 and CN1-B10 (blue/gray)
  - RTD, check terminals CN1-Z6 and CN1-B4 (violet/yellow)
4. If the measured resistance is outside the range listed in **Table 7-6**, repeat the measurements at the sensor terminals.
5. Reinsert the terminal blocks and restore power to the transmitter.
6. Use the DMM to troubleshoot the flowmeter.

**Table 7-6. Nominal resistance ranges for flowmeter circuits**

**Notes**

- Temperature sensor value increases 0.38675 ohms per °C increase in temperature
- Nominal resistance values will vary 40% per 100°C. However, confirming an open coil or shortened coil is more important than any slight deviation from the resistance values presented below.
- Resistance across terminals 6 and 8 (right pickoff) should be within 10% of resistance across terminals 5 and 9 (left pickoff).
- Resistance values depend on the sensor model and date of manufacture.

Circuit	Wire colors	Sensor terminals	Transmitter terminals	Normal resistance range
Drive coil	Brown to red	1 to 2	CN1-Z2 to CN1-B2	8 to 2650 Ω
Left pickoff	Green to white	5 to 9	CN1-Z8 to CN1-B8	15.9 to 300 Ω
Right pickoff	Blue to gray	6 to 8	CN1-Z10 to CN1-B10	15.9 to 300 Ω
Temperature sensor	Orange to violet	3 to 7	CN1-B6 to CN1-Z6	100 Ω at 0°C + 0.38675 Ω / °C
Lead length compensator	Yellow to violet	4 to 7	CN1-B4 to CN1-Z6	100 Ω at 0°C + 0.38675 Ω / °C



## 7.7 Master reset

Use the switches on the transmitter control board to perform a master reset (see **Figure 1-1**, page 2, for the location of the control board). A master reset causes communication options to default to the setup used by HART Communicators, causes all other configuration options to return to their default values, and **requires complete characterization and reconfiguration of the transmitter.**

**Table 7-7**, page 80, lists master reset defaults for characterization and configuration variables.

**⚠ CAUTION**

**All configuration data will be lost by performing a master reset.**

Before performing a master reset, phone the Micro Motion Customer Service Department:

- In the U.S.A., phone 1-800-522-6277, 24 hours
- Outside the U.S.A., phone 303-530-8400, 24 hours
- In Europe, phone +31 (0) 318 549 443
- In Asia, phone 65-770-8155

To perform a master reset:

1. Note the position of switch 5.
2. Shut off power to the transmitter.
3. Set switches 1, 2, and 3 to the OFF position.
4. Set switches 4, 5, 6, and 10 to the ON position.
5. Restore power. Wait until the "Msg" indicator appears on the transmitter display.
6. Set switches 4, 6, and 10 to the OFF position.
7. Return switch 5 to its original position.
8. Shut off power to the transmitter. Wait 30 seconds.
9. Restore power.

If switches are left in the ON position, another master reset will occur the next time power to the transmitter is shut off and then restored. **To avoid an unintentional master reset**, set switches 4, 6, and 10 to the OFF position after performing a master reset.

After the user performs a master reset, the blinking "Msg" indicator appears in the lower right corner of the display to indicate the presence of a status message. If the user scrolls to the message screen, it reads "NOT CONFIGURED", indicating the transmitter memory contains default variables.

To characterize the sensor and configure the transmitter, use a HART communicator, the ProLink program, or a Modbus host. For more information, see **Section 2.2**, page 4. After characterization is completed, the message display reads "Sensor OK \*ERROR CLEARED\*", and the transmitter is ready for normal operation.

## Troubleshooting continued

**Table 7-7. Default values after a master reset**

<b>Characterization variables</b>			
	<b>Default</b>		<b>Default</b>
Flow calibration factor	1.00005.13	Mass flow factor	1.0
Density		Volume flow factor	1.0
Density A	0.0000 g/cc	Density factor	1.0
K1 density constant	5000.00	Pressure	
Density B	1.0000 g/cc	Pressure polling	No
K2 density constant	50000.00	Field device tag	DP CELL!
Density temperature coefficient	4.44% per 100°C	Pressure input at 4 mA	0.00 psi
FD density constant	0.000	Pressure input at 20 mA	1000.00 psi
Temperature calibration factor	1.00000T0000.0	Pressure correction for flow	0.00% per psi
		Pressure correction for density	0.00 g/cc per psi
		Flow calibration pressure	0.00 psi
<b>Measurement units</b>			
	<b>Default</b>		<b>Default</b>
Mass flow unit	g/sec	Temperature unit	°C
Volume flow unit	l/sec	Pressure unit	psi
Density unit	g/cc		
<b>Field device variables</b>			
	<b>Default</b>		<b>Default</b>
Mass flow cutoff	0.00 g/sec	Low slug flow limit	0.0000 g/cc
Volume flow cutoff	0.0000 l/sec	High slug flow limit	5.0000 g/cc
Flow direction	Forward only	Internal damping on density	2.00 sec
Internal damping on flow	0.80 sec	Internal damping on temperature	4.00 sec
<b>Transmitter output variables</b>			
	<b>Default</b>		<b>Default</b>
Primary mA output variable	Mass flow	Frequency/pulse output variable	Mass flow
Upper range value	160.00 g/sec	Frequency	10000.00 Hz
Lower range value	-160.00 g/sec	Rate	15000.00 g/sec
Added damping	0.00 sec	Maximum pulse width	0.50 sec
Secondary mA output variable	Temperature	Control output	Flow direction
Upper range value	450.00°C	Slug duration	1.00 sec
Lower range value	-240.00°C	Polling address	0
Added damping	0.00 sec	Burst mode	Off
<b>Device information</b>			
	<b>Default</b>		<b>Default</b>
Transmitter tag name	M. RESET	Sensor model	Unknown
Description	CONFIGURE XMTR	Sensor flow tube material	Unknown
Message	MASTER RESET - ALL DATA DESTROYED	Sensor flange type	Unknown
Date	01/JAN/1995	Sensor flow tube liner material	None
<b>Communication settings</b>			
	<b>Default with switch 5* set to STD COMM</b>	<b>Default with switch 5* set to USER DEF</b>	
Stop bits and parity	1 stop bit, odd parity	1 stop bit, odd parity	
Protocol, physical layer, baud rate	HART Bell 202 on primary mA at 1200 baud, and Modbus RTU on RS-485 at 9600 baud	HART on RS-485 at 1200 baud	

\*For information about switches and switch settings, see **Section 2.3**, page 5.

## Troubleshooting continued

### 7.8 Additional information about troubleshooting

For more information about troubleshooting the RFT9739 transmitter, see any of the following instruction manuals or AMS on-line help:

- Using the HART Communicator with Micro Motion Transmitters
- Using ProLink Software with Micro Motion Transmitters
- Using Modbus Protocol with Micro Motion Transmitters

### 7.9 Customer service

For technical assistance, phone the Micro Motion Customer Service Department:

- In the U.S.A., phone 1-800-522-6277, 24 hours
- Outside the U.S.A., phone 303-530-8400, 24 hours
- In Europe, phone +31 (0) 318 549 443
- In Asia, phone 65-770-8155



# RFT9739 Specifications

## Performance specifications

Sensor model		Mass flow accuracy*
ELITE	liquid	$\pm 0.10\% \pm [(\text{zero stability} / \text{flow rate}) \times 100]\%$ of rate
	gas	$\pm 0.50\% \pm [(\text{zero stability} / \text{flow rate}) \times 100]\%$ of rate
F-Series	liquid	$\pm 0.20\% \pm [(\text{zero stability} / \text{flow rate}) \times 100]\%$ of rate
	gas	$\pm 0.70\% \pm [(\text{zero stability} / \text{flow rate}) \times 100]\%$ of rate
D (except DH38), DT and DL	liquid	$\pm 0.15\% \pm [(\text{zero stability} / \text{flow rate}) \times 100]\%$ of rate
	gas	$\pm 0.65\% \pm [(\text{zero stability} / \text{flow rate}) \times 100]\%$ of rate
DH38	liquid	$\pm 0.15\% \pm [(\text{zero stability} / \text{flow rate}) \times 100]\%$ of rate
	gas	$\pm 0.50\% \pm [(\text{zero stability} / \text{flow rate}) \times 100]\%$ of rate

Sensor model		Mass flow repeatability *
ELITE	liquid	$\pm 0.05\% \pm [\Omega(\text{zero stability} / \text{flow rate}) \times 100]\%$ of rate
	gas	$\pm 0.25\% \pm [(\text{zero stability} / \text{flow rate}) \times 100]\%$ of rate
F-Series	liquid	$\pm 0.10\% \pm [\Omega(\text{zero stability} / \text{flow rate}) \times 100]\%$ of rate
	gas	$\pm 0.35\% \pm [(\text{zero stability} / \text{flow rate}) \times 100]\%$ of rate
D (except DH38), DT and DL	liquid	$\pm 0.05\% \pm [\Omega(\text{zero stability} / \text{flow rate}) \times 100]\%$ of rate
	gas	$\pm 0.30\% \pm [(\text{zero stability} / \text{flow rate}) \times 100]\%$ of rate
DH38	liquid	$\pm 0.05\% \pm [\Omega(\text{zero stability} / \text{flow rate}) \times 100]\%$ of rate
	gas	$\pm 0.25\% \pm [(\text{zero stability} / \text{flow rate}) \times 100]\%$ of rate

Sensor model		Density accuracy		Density repeatability	
		g/cc	kg/m <sup>3</sup>	g/cc	kg/m <sup>3</sup>
ELITE (except CMF010P)	liquid only	$\pm 0.0005$	$\pm 0.5$	$\pm 0.0002$	$\pm 0.2$
ELITE CMF010P	liquid only	$\pm 0.002$	$\pm 2.0$	$\pm 0.001$	$\pm 1.0$
F-Series	liquid only	$\pm 0.002$	$\pm 2.0$	$\pm 0.001$	$\pm 1.0$
D6, D12, D25, D40, DH100, DH150	liquid only	$\pm 0.002$	$\pm 2.0$	$\pm 0.001$	$\pm 1.0$
DH6, DH12, DH38	liquid only	$\pm 0.004$	$\pm 4.0$	$\pm 0.002$	$\pm 2.0$
D65, DL65, DT65, D100, DT100, D150, DT150, DH300	liquid only	$\pm 0.001$	$\pm 1.0$	$\pm 0.0005$	$\pm 0.5$
D300, D600, DL100, DL200	liquid only	$\pm 0.0005$	$\pm 0.5$	$\pm 0.002$	$\pm 2.0$

Sensor model	Temperature accuracy	Temperature repeatability
All sensors	$\pm 1^\circ\text{C} \pm 0.5\%$ of reading in $^\circ\text{C}$	$\pm 0.02^\circ\text{C}$

\* Flow accuracy includes the combined effects of repeatability, linearity, and hysteresis. All specifications for liquids are based on reference conditions of water at 68 to 77 °F (20 to 25°C) and 15 to 30 psig (1 to 2 bar), unless otherwise noted. For values of zero stability, refer to product specifications for each sensor.

**Functional specifications**

**Output signals**

**Analog**

Two independently configured analog outputs, designated as primary and secondary, can represent mass or volumetric flow rate, density, temperature, event 1 or event 2. With a pressure transmitter, can also provide indication for pressure. Internally powered, can be selected as 4-20 mA or 0-20 mA current outputs. Outputs cannot be changed from active to passive. Galvanically isolated to  $\pm 50$  VDC, 1000 ohm load limit. Out-of-range capability: 0-22 mA on 0-20 mA output; 3.8-20.5 mA on 4-20 mA output.

**Milliamp (mA) output rangeability**

Flow

Maximum span determined by sensor specifications.

Range limit determined by sensor maximum rate.

Minimum recommended span (% of nominal flow range):

ELITE sensors	2.5%
F-Series sensors	10%
D, DT, and DL sensors	10%
D300 and D600 sensors	5%
High-pressure (DH) sensors	20% typical

Density

Range limit 0 to 5 g/cc (0 to 5000 kg/m<sup>3</sup>)

Minimum span 0.05 g/cc (50 kg/m<sup>3</sup>)

Temperature

Range limit -400 to 842°F (-240 to 450°C)

Minimum span 36°F (20°C)

**Frequency**

One frequency/pulse output can be configured to indicate mass flow rate, volumetric flow rate, mass total (inventory), or volume total (inventory), independent of analog outputs. Internally powered, 0-15 V square wave, unloaded; 2.2 kohm impedance at 15 V, galvanically isolated to  $\pm 50$  VDC. In open collector configuration: sinking capability, 0.1 amps in "on" condition (0 volt level), 30 VDC compliance in "off" condition. Signal can be scaled up to 10,000 Hz. Out-of-range capability to 15,000 Hz. Programmable pulse width for low frequencies.

**Dual-channel frequency**

Approved for custody transfer applications, a dual-channel frequency output, referred to as frequency A and frequency B. Phase shift between channels is 90 degrees. Output derived from the primary frequency, and represents the same process variable as the frequency/pulse output, but with half the frequency. All specifications match frequency/pulse output except: Signal can be scaled up to 5,000 Hz; out-of-range capability to 7500 Hz. The output complies with VDE/VDI 2188 when jumper JP1 is installed.

### **Optocoupler output**

The optocoupler is an externally powered output. Signal voltage: low level 0-2 VDC, high level 16-30 VDC. Maximum signal current 0.01 amp. Maximum capacitive load 150 nF at 10 kHz. Output is derived from the primary frequency, and represents the same process variable as the frequency/pulse output. The output complies with VDE/VDI 2188.

### **Control**

One control output can represent flow direction, fault alarm, zero in progress, event 1 or event 2. Internally powered, digital level, 0 or 15 V, 2.2 kohm pull-up, galvanically isolated to  $\pm 50$  VDC. In open collector configuration: sinking capability, 0.1 amps in "on" condition (0 volt level), 30 VDC compliance in "off" condition.

### **Communication**

Switch allows selection of preset or user-defined settings.

- Default preset-settings: HART protocol over Bell 202, on the primary mA output, 1200 baud; Modbus protocol in RTU mode, on the RS-485 output, 9600 baud; 1 stop bit, odd parity.
- Default user-defined settings: HART protocol, on the RS-485 output, 1200 baud, 1 stop bit, odd parity.

Bell 202 signal is superimposed on primary variable mA output, and available for host system interface. Frequency 1.2 and 2.2 kHz, amplitude 0.8 V peak-to-peak, 1200 baud. Requires 250 to 1000 ohms load resistance.

RS-485 signal is a  $\pm 5$  V square wave referenced to transmitter ground. Baud rates between 1200 baud and 38.4 kilobaud can be selected.

## **Additional outputs**

### **Sensor frequency**

For use with Micro Motion peripheral devices, 8 V peak-to-peak at sensor natural frequency, referenced to sensor ground, 10 kohm output impedance.

### **Sensor temperature**

For use with Micro Motion peripheral devices, 5 mV/ $^{\circ}$ C, referenced to signal ground, 10 kohm output impedance.

**API gravity**

API gravity references to 60°F (15°C). Uses correlation based on API equation 2540 for Generalized Petroleum Products.

Accuracy of corrected density calculation relative to API-2540 from 0 to 300°F:

Process fluid	g/cc	kg/m <sup>3</sup>	°API
Diesel, heater, and fuel oils	±0.0005	±0.5	±0.2
Jet fuels, kerosenes, and solvents	±0.002	±2.0	±0.5
Crude oils and JP4	±0.004	±4.0	±1.0
Lube oils	±0.01	±10	±2.0
Gasoline and naphthenes	±0.02	±20	±5.0

Minimum 4-20 mA span: 10°API

**Standard volume**

Outputs standard volume at 60°F or 15°C for Generalized Petroleum Products when °API is selected as density unit of measure. Accuracy of standard volume measurements depends on accuracies of mass flow rate, density, temperature and temperature-corrected °API calculation, and can be estimated using the root mean square method. Standard volume accuracy of ±0.5% of rate is typically attainable for Generalized Petroleum Products such as fuel oils, jet fuels, and kerosenes.

**Pressure compensation**

The analog input can accept a signal from a pressure transmitter for pressure compensation of flow and density. Range, 0-25 mA. Can be used to power independent pressure or differential pressure transmitter. Voltage sourcing capability, 15 V. Input impedance, 100 ohms.

**Low-flow cutoff**

Flow values below the low-flow cutoff cause digital and frequency outputs to default to zero flow levels. Each mA output may be configured for an additional low-flow cutoff.

**Slug-flow limits**

Transmitter senses density outside limits. Flow output remains at last measured value, for a programmed time of 0 to 60 seconds, before defaulting to zero flow.

**Damping**

Wide range of programmed filter time constants for damping on flow, density, and temperature. Additional damping may be applied to mA outputs.

**Fault indication**

Faults can be indicated by user-selected downscale (0-2 mA, 0 Hz) or upscale (22-24 mA, 15-19 kHz) output levels. The control output can also be configured to indicate a fault condition at 0 V.



**Output testing**

Output testing can be conducted with a HART Communicator, the ProLink program, a Modbus host, or AMS software.

**Current source**

Transmitter can produce a user-specified current between 0 and 22 mA on a 0-20 mA output, or between 2 and 22 mA on a 4-20 mA output.

**Frequency source**

Transmitter can produce a user-specified frequency between 0.1 and 15,000 Hz.

**Display**

Display is a 2-line, 16-character, alphanumeric liquid crystal display (LCD). Using the transmitter's scroll function, the user can view flow rate, density, temperature, mass and volume totals and inventory levels, and status messages on the LCD. A reset button allows the user to reset the transmitter's flow totalizers and communication parameters, and perform the flowmeter zeroing procedure.

**Power-supply options and fuses**

110/115 VAC  $\pm$  25%, 48 to 62 Hz, 10 watts typical, 15 watts maximum, fused with UL/CSA 250mA/250V, time-lag, 5x20mm.

220/230 VAC  $\pm$  25%, 48 to 62 Hz, 10 watts typical, 15 watts maximum, fused with UL/CSA 250mA/250V, time-lag, 5x20mm.

All AC-powered RFT9739 transmitters comply with low-voltage directive 73/23/EEC per IEC 1010-1 with Amendment 2.

12 to 30 VDC, 7 watts typical, 14 watts maximum, fused with UL/CSA 2A/125V, medium-lag, 5x20mm. At startup, transmitter power source must provide a minimum of 2 amperes of short-term current at a minimum of 12 volts at the transmitter's power input terminals.

**Environmental limits**

**Ambient temperature limits**

Operating: 32 to 122°F (0 to 50°C)

Storage: -4 to 158°F (-20 to 70°C)

**Humidity limits**

Meets SAMA PMC 31.1-1980

**Vibration limits**

Meets SAMA PMC 31.1-1980, Condition 1

**Environmental effects**

**EMI effect**

Rack-mount RFT9739 transmitters feature enhanced EMI immunity and the requirements of the EMC directive 89/336/EEC per EN 50081-1 (January 1992) and EN 50082-2 (March 1995) when operated at nominal rated flow measurement range. Enhanced EMI immunity is required for transmitters installed in the European Community after 1 January 1996.

For specific EMC effects within the EC, the Technical EMC file may be reviewed at Fisher-Rosemount Veenendaal.

All RFT9739 transmitters meet the requirements of SAMA PMC 33.1 (October 1978), Class 1, A, B, C (0.6% span) at nominal flow rate. All RFT9739 transmitters meet the recommendations of ANSI/IEEE C62.41 (1991) for surge and EFT.

To meet the above specifications, the transmitter must be installed with an approved Micro Motion sensor, and the sensor cable must be either doubly shielded with full contact glands, or installed in continuous, fully bonded metallic conduit. The transmitter and sensor must be directly connected to a low-impedance (less than 1 ohm) earth ground. Transmitter outputs must be run in standard twisted-pair, shielded instrument wire.

**Ambient temperature effect on transmitter**

On mA outputs:  $\pm 0.005\%$  of span/ $^{\circ}\text{C}$   
On temperature output:  $\pm 0.01^{\circ}\text{C}/^{\circ}\text{C}$   
On mA input:  $\pm 0.01\%$  of span/ $^{\circ}\text{C}$

**Hazardous area classifications**

When properly installed with an approved sensor, the RFT9739 rack-mount transmitter can be installed in the following areas:

**UL**

Non-hazardous locations. Provides nonincendive sensor outputs for use in Class I, Div. 2, Groups A, B, C, and D; or intrinsically safe sensor outputs for use in Class I, Div. 1, Groups C and D, or Class II, Groups E, F, and G.

**CSA**

Non-hazardous locations. Connections to sensor are intrinsically safe for use in Class I, Div. 1, Groups C, D, and Class II, Groups E, F, and G.

**CENELEC**

Safe area only. Connections to sensor are intrinsically safe in [EEx ib] IIC areas.

**Physical specifications**

**Housing**

19-inch rack, European standard DIN 41494: 128 mm (3HE) high x 142 mm (28TE) wide x 231.9 mm deep.

**Electrical connections**

Two connectors per DIN 41612, type F. Choose either fast-on (wire-pin) solder connectors (standard) or Y-shaped screw-terminal connectors (optional). Sensor connectors and output connectors are not interchangeable.

**Weight**

4.4 lb (2.0 kg)



Appendix  
**B**

# Ordering Information

## RFT9739 model number matrix

Code	Transmitter model
------	-------------------

RFT9739 RFT9739 transmitter

Code	Housing options
------	-----------------

R Rack-mount

Code	Power supply
------	--------------

1 110/115 VAC  
 2 220/230 VAC  
 3 12 to 30 VDC

Code	Configuration
------	---------------

E Enhanced EMI immunity (CE compliant) - requires installation with Micro Motion cable type CPLTJ or CFEPJ installed in conduit, or type CPLTS, CPLTA, CFEPS, or CFEPA installed with approved cable glands

Code	Approval
------	----------

M Micro Motion standard - no approvals  
 U UL intrinsically safe  
 C CSA  
 B CENELEC, intrinsically safe sensor outputs

Code	Glands
------	--------

F Fast-on/solder terminals  
 S Y-shaped screw terminals

## Micro Motion instruction manuals

- |                            |   |
|----------------------------|---|
| <b>Sensors</b>             | <ul style="list-style-type: none"><li>• ELITE<sup>®</sup> Sensor Instruction Manual</li><li>• R-Series Flowmeter Instruction Manual</li><li>• R-Series Flowmeter with FOUNDATION<sup>™</sup> fieldbus</li><li>• T-Series Flowmeter Instruction Manual</li><li>• F-Series Sensor Instruction Manual</li><li>• Model D and DT Sensors Instruction Manual</li><li>• Model DL Sensor Instruction Manual</li></ul>   |
| <b>Transmitters</b>        | <ul style="list-style-type: none"><li>• ALTUS<sup>™</sup> Installation Manual</li><li>• ALTUS<sup>™</sup> Detailed Setup Manual</li><li>• ALTUS<sup>™</sup> Density Applications Manual</li><li>• ALTUS<sup>™</sup> Net Oil Computer Manual</li><li>• Installing Relays for the ALTUS<sup>™</sup> Applications Platform</li><li>• RFT9739 Field-Mount Transmitter Instruction Manual</li><li>• RFT9739 Rack-Mount Transmitter Instruction Manual</li><li>• IFT9701 Transmitter Instruction Manual</li><li>• Model 5300 Transmitter with FOUNDATION<sup>™</sup> fieldbus</li><li>• RFT9709 Transmitter Instruction Manual</li><li>• RFT9712 Remote Flow Transmitter Instruction Manual</li></ul> |
| <b>Communications</b>      | <ul style="list-style-type: none"><li>• Using ProLink<sup>®</sup> Software with Micro Motion<sup>®</sup> Transmitters</li><li>• Using the HART<sup>®</sup> Communicator with Micro Motion<sup>®</sup> Transmitters</li><li>• Using Modbus<sup>®</sup> Protocol with Micro Motion<sup>®</sup> Transmitters</li><li>• RFT9739 Transmitter-Specific Command Specification</li><li>• RFT9709 Transmitter-Specific Command Specification</li><li>• RFT9712 Transmitter-Specific Command Specification</li></ul>  |
| <b>Peripheral products</b> | <ul style="list-style-type: none"><li>• DMS Density Monitoring System Instruction Manual</li><li>• DRT Digital Rate Totalizer LCD Instruction Manual</li><li>• DRT Digital Rate Totalizer LED Instruction Manual</li><li>• FMS-3 Flow Monitoring System LCD Instruction Manual</li><li>• FMS-3 Flow Monitoring System LED Instruction Manual</li><li>• NFC Net Flow Computer Instruction Manual</li><li>• NOC Net Oil Computer Instruction Manual</li><li>• PI 4-20 Process Indicator</li></ul>   |
| <b>Wiring instructions</b> | <ul style="list-style-type: none"><li>• 9-Wire Flowmeter Cable Preparation and Installation</li><li>• Cable Gland Assembly Instructions</li><li>• UL-D-IS Installation Instructions</li><li>• CSA-D-IS Installation Instructions</li><li>• SAA-D-IS Installation Instructions</li><li>• Power-Supply Wiring for the D600 Sensor</li><li>• Input Signal Wiring for Peripheral Devices</li></ul>  |

# Theory of Operation

The flow tubes of the Coriolis mass flow sensor are driven to vibrate at their natural frequency by a magnet and drive coil attached to the apex of the bent tubes (see **Figure C-1**). An AC drive control amplifier circuit in the transmitter reinforces the signal from the sensor's left velocity pickoff coil to generate the drive coil voltage. The amplitude of this drive coil voltage is continuously adjusted by the circuit to maintain a constant, low amplitude of flow tube displacement, minimizing stress to the tube assembly.

**Figure C-1.**  
Coriolis mass flow sensor

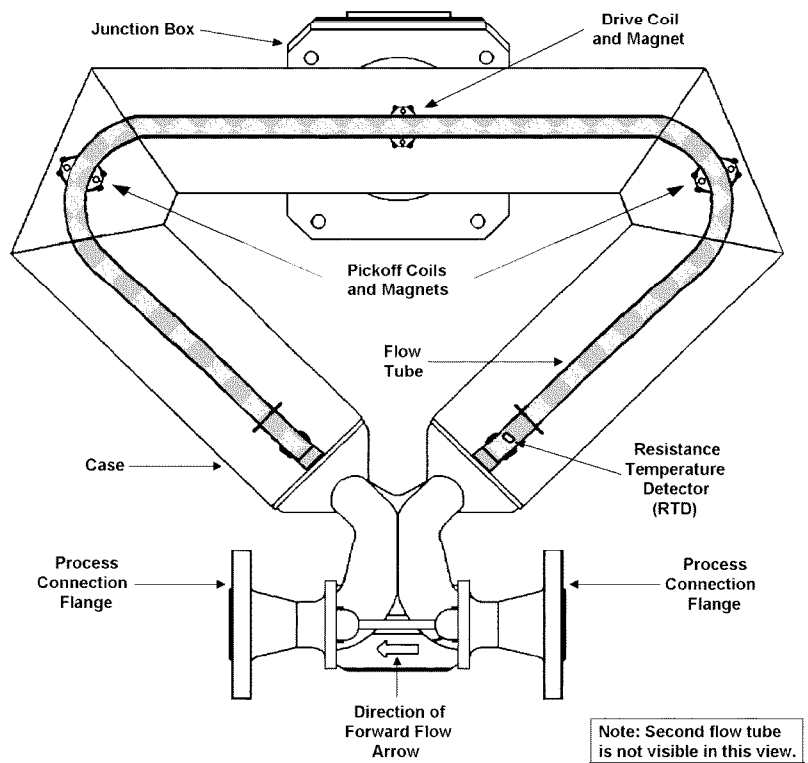

### Mass flow measurement

The vibrating motion of the flow tube, combined with the momentum of the fluid flowing through the tubes, induces a Coriolis force that causes each flow tube to twist in proportion to the rate of mass flow through the tube during each vibrational cycle. Since one leg of the flow tube lags behind the other leg during this twisting motion, the signals from sensors on the two tube legs can be compared electronically to determine the amount of twist. The transmitter measures the time delay between the left and right pickoff signals using precision circuitry and a high frequency crystal controlled clock. This "delta time" value is digitally filtered to reduce noise and improve the measurement resolution.

Delta time is multiplied by the flow calibration factor to determine the mass flow rate. Since temperature affects flow tube stiffness, the amount of twist produced by the Coriolis force will be affected by the flow tube temperature. The measured flow rate is continuously adjusted by the transmitter, which monitors the output of a platinum element resistance temperature detector (RTD) attached to the outside surface of the flow tube. The transmitter measures the sensor temperature using a three-wire RTD bridge amplifier circuit. The voltage out of the amplifier is converted to a frequency and is digitized by a counter read by the microprocessor.

### Density measurement

The Coriolis mass flow sensor also functions as a vibrating tube density meter. The natural frequency of the tube assembly is a function of tube stiffness, tube geometry, and the mass of the fluid the tube contains. Therefore, fluid density can be derived from a measurement of tube frequency.

The transmitter measures the time period of each vibrational cycle using a high-frequency clock. This measurement is digitally filtered, and density is calculated using the density calibration factors for the sensor after compensating the sensed natural frequency for known changes in the tube stiffness due to operating temperature. The transmitter calculates volumetric flow by dividing the measured mass flow by the measured density.

### API gravity

If °API is selected as the density unit, the transmitter calculates standard volume for Generalized Petroleum Products according to API-2540. The transmitter calculates volume flow and volume total at 60°F or 15°C, depending on the temperature unit:

- If degrees Fahrenheit or degrees Rankine is selected as the temperature unit, the transmitter calculates volume at 60°F.
- If degrees Celsius or Kelvin is selected as the temperature unit, the transmitter calculates volume at 15°C.

From the operating density (fluid density at line conditions) and operating temperature of a given petroleum fluid, the standard density (density at 60°F or 15°C) can be determined directly from API thermal expansion tables, or by using API equation API-2540:



$$\rho_o = \rho_s \cdot \exp[-\alpha\Delta T(1 + 0.8\alpha\Delta T)]$$

where:

- $\rho_o$  = operating density
- $\rho_s$  = standard density
- $\Delta T$  = temperature difference from base (standard) temperature
- $\alpha$  =  $K_0 / (\rho_s)^2 + K_1 / \rho_s$ , where  $K_0$  and  $K_1$  are constants

The equation is iterative, and requires significant calculation time to generate one reading. The transmitter software contains a simplification of this correlation to maximize sampling frequency of the measurement. Accuracy of the Micro Motion correlation is  $\pm 0.0005$  g/cc ( $\pm 0.5$  kg/m<sup>3</sup>) relative to the API-2540 equation. After temperature correction to 60°F (15°C), the density is converted to °API by the following expression:

$$\text{Degrees API} = (141.5/\text{standard specific gravity}) - 131.5$$

The  $K_0$  and  $K_1$  terms in the API-2540 equation are constants characteristic of different types of Generalized Petroleum Products. Separate API tables exist for crude oils, distillates, gasolines, lube oils, and other products. The correlation in the RFT9739 is based on the API constants for Generalized Petroleum Products from 2 to 95°API over an operating temperature range of 0 to 300°F. As fluid density or operating temperature extends beyond these values, the RFT9739 correlation error will increase. Density calibration must be performed in units of g/cc for the API correlation to be correct.

### API standard volume

If °API is selected as the density unit, the RFT9739 automatically calculates standard volume at 60°F or at 15°C based on the following expression:

$$\text{Standard volume} = \text{mass flow}/\text{standard density}$$

Accuracy of standard volume measurement is based on the accuracies of the following factors:

- Mass rate measurement
- Operating density measurement
- Temperature measurement
- RFT9739 correlation to API tables

The accuracy of each factor varies based on the process operating conditions and fluid that is being measured. For Generalized Petroleum Products, standard volume will be accurate within  $\pm 0.5\%$  of the flow rate. Because the temperature correction correlations for density are based on API equations, the RFT9739 standard volume output can be used only for Generalized Petroleum Products or materials that exhibit the same thermal expansion characteristics as Generalized Petroleum Products.

**Pressure compensation**

A pressure transmitter can be connected to the RFT9739 for pressure compensation. The RFT9739 or an external source can supply power to the pressure transmitter.

If the input is configured to indicate gauge pressure, the transmitter uses the pressure input to account for effects of pressure on the flow tubes of certain sensors. Not all sensors are affected by pressure. In this mode, the pressure effect is calculated as the percent change in the flow rate per psi change in pressure and/or the amount of change in density, in g/cc, per psi change in pressure.

**Output variables**

Measured variables can be output in a variety of ways from the RFT9739. Mass or volume flow rate can be output as an isolated 4-20 or 0-20 mA signal over either of two sets of output terminals. Alternatively, either mA output can be configured to indicate temperature, density, pressure, event 1 or event 2.

Mass or volume flow pulses from the isolated frequency output terminals can be scaled to 10,000 Hz for compatibility with PLCs, batch controllers, and totalizers.

All measured variables, including totalizers for batch and inventory, can be accessed digitally. The transmitter can use the Bell 202 physical layer at 1200 baud superimposed on the primary mA signal and/or the RS-485 physical layer at 1200 baud to 38.4 kilobaud. The transmitter can use HART protocol over the Bell 202 or RS-485 physical layer, Modbus protocol over the RS-485 physical layer, or HART over the Bell 202 layer and Modbus over the RS-485 layer.

A logic output can be programmed to indicate the flow direction, a fault alarm, or a zero in progress condition. The transmitter operational status is also indicated on the transmitter display.

# HART® Communicator Menu Trees

Figure D-1. On-line menu

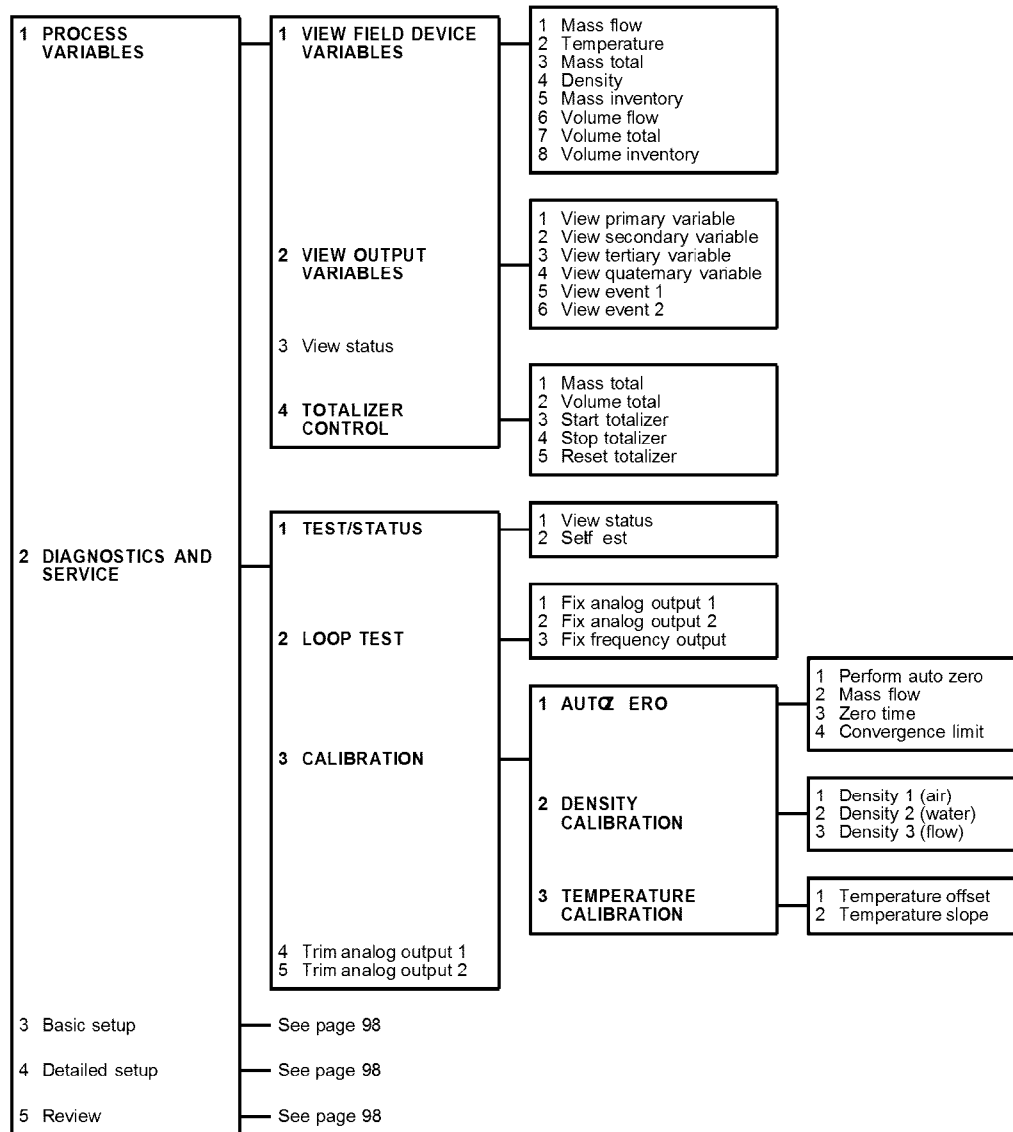
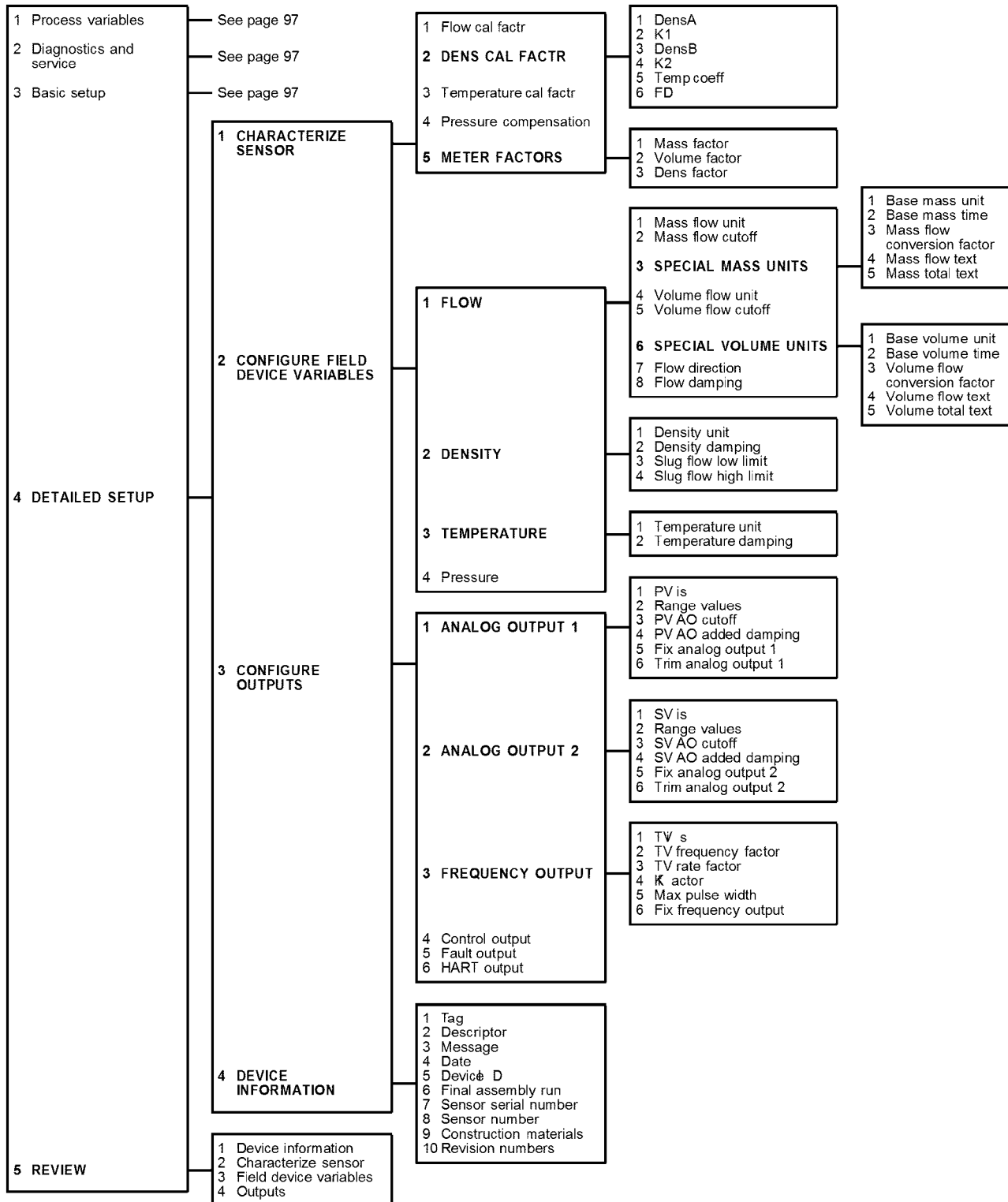

Figure D-1. On-line menu continued



**HART® Communicator Menu Trees** continued

**Fast key**

The fast key code is a sequence of numerical button presses that corresponds to a specific menu option. Compare the fast key sequences in the table below with the menu options in the menu trees on pages 97 and 98.

Function/variable	Fast-key sequence
Analog output 1	4, 3, 1
Analog output 2	4, 3, 2
Analog 1 range values	3, 3
Analog 2 range values	3, 5
Auto zero	2, 3, 1
Basic setup	3
Calibration	2, 3
Characterize sensor	4, 1
Control output	4, 3, 4
Date	4, 4, 4
Density calibration factors	4, 1, 2
Density calibration procedure	2, 3, 2
Density variables	4, 2, 2
Descriptor	4, 4, 2
Device ID	4, 4, 5
Device information	4, 4
Detailed setup	4
Device information	4, 4
Diagnostics and service	2
Events	4, 5
Fault output	4, 3, 5
Field device variables	4, 2
Final assembly number	4, 4, 6
Fix analog output 1	2, 2, 1
Fix analog output 2	2, 2, 2
Fix frequency output	2, 2, 3
Flow calibration factor	4, 1, 1
Flow variables	4, 2, 1
Frequency factor	3, 6
Frequency output	4, 3, 3
HART output	4, 3, 6
Loop test	2, 2
Mass flow variables	4, 2, 1
Mass total	1, 4, 1
Output variables	4, 3
Perform auto zero	2, 3, 1, 1

Function/variable	Fast-key sequence
Polling address	4, 3, 6, 1
Pressure compensation	4, 1, 5
Pressure unit	4, 2, 4
Primary variable	1, 2, 1
Primary variable unit	3, 2
Process variables	1
Quarternary variable	1, 2, 4
Range values	3
Rate factor	3, 7
Reset totalizer	1, 4, 5
Review	5
Revision numbers	4, 4
Secondary variable	1, 2, 2
Secondary variable unit	3, 4
Self test	2, 1, 2
Sensor serial number	4, 4, 7
Sensor model	4, 4, 8
Start totalizer	1, 4, 3
Status	1, 3
Stop totalizer	1, 4, 4
Tag	3, 1
Temperature calibration factors	4, 1, 3
Temperature calibration procedure	2, 3, 4
Temperature variables	4, 2, 3
Tertiary variable	1, 2, 3
Tertiary variable frequency factor	3, 6
Tertiary variable rate factor	3, 7
Test/status	2, 1
Totalizer control	1, 4
Trim analog output 1	2, 4
Trim analog output 2	2, 5
Volume flow variables	4, 2, 1
Volume total	1, 4, 2



# Transmitter Version Identification

## To identify a Version 3 RFT9739 rack-mount transmitter:

A Version 3 transmitter has a back-panel that is different from older versions. For comparison, refer to **Figure E-1**.

- The Version 3 back panel has text between connectors CN1 and CN2, which reads BACKPLANE RFT9739RM PHASE 2/PHASE 3.
- The Version 2 back panel does not have text between connectors CN1 and CN2 to identify the transmitter version.
- Earlier versions have a 3-position power-supply terminal block at connector CN3.

Although an examination of the back panel can determine whether the RFT9739 is a Version 3 transmitter, it does not identify the software version. **To identify the software version:**

1. When shipped from the factory, a sticker affixed to the side of the transmitter housing identifies the transmitter software version.
2. If the identification sticker has been removed, use a HART device to identify the software version. See one of the following communications manuals for instructions:
  - Using the HART Communicator with Micro Motion Transmitters
  - Using ProLink Software with Micro Motion Transmitters

Figure E-1. RFT9739 back panels

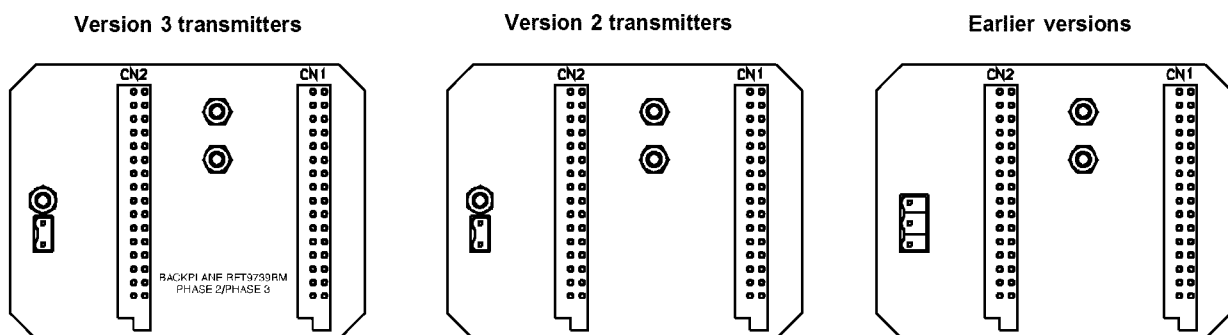





# Replacing Older Transmitters

## Step 1 Disconnecting the old transmitter

 <b>WARNING</b>
<p><b>Hazardous voltage can cause severe injury or death.</b></p> <p>Shut off power before disconnecting the transmitter.</p>

 <b>CAUTION</b>
<p><b>Process control will stop when the transmitter is disconnected.</b></p> <p>Set control devices for manual operation before disconnecting the transmitter.</p>

Follow these steps to wire the RFT9739 in place of the old transmitter:

- a. Shut off power to the transmitter.
- b. Open the transmitter wiring compartment covers. **Do not disconnect wires from the transmitter yet.** Wires will need to be moved from the old transmitter terminals to the appropriate terminals on the RFT9739 transmitter. Make note of which terminals the wires are connected to **before removing them from the old transmitter.**
  - **Figure F-1** shows the location of terminals on a Model RFT9739
  - **Figure F-2** shows the location of terminals on a Model RE-01
  - **Figure F-3** shows the location of terminals on a Model RFT9712
- c. Detach wires from the old transmitter, then remove the transmitter.
- d. Proceed to Step 2, page 104.

## Step 2 Determining type of RTD in the sensor

Determine whether the sensor has a platinum or copper RTD (resistance temperature detector). The type of RTD determines how the transmitter and sensor must be wired and configured.

All sensors shipped after October 1986 have **platinum** RTDs. For older sensors, or if the date of manufacture is not known, follow these steps to determine the sensor's RTD type:

- a. Identify the sensor serial number on the tag that is attached to the outside of the sensor case.
  - If the sensor serial number is higher than 87263, the sensor has a **platinum** RTD. See "Installing the RFT9739 transmitter", page 105, if the sensor serial number is higher than 87263.
  - If the serial number is 87263 or lower, check resistance values as described below.
  
- b. If the sensor and transmitter were properly wired with Micro Motion color-coded cable, the orange and violet wires provide temperature detection. These wires were connected to RE-01 terminals 3 and 9, or RFT9712 terminals 3 and 7, or RFT9729 terminals CN1-14d and CN1-16d. The yellow or shield wire from the orange/violet pair, which was connected to RE-01 terminal 6, or RFT9712 terminal 4, or RFT9729 terminal CN1-12d, provides temperature lead length compensation.

Use a digital multimeter (DMM) to check resistance between the orange, violet, and yellow wires. Refer to **Table F-1** to determine the sensor's RTD type. Contact the Micro Motion Customer Service Department for further assistance.

- In the U.S.A., phone 1-800-522-6277, 24 hours
- Outside the U.S.A., phone 303-530-8400, 24 hours
- In Europe, phone +31 (0) 318 549 443
- In Asia, phone 65-770-8155

- c. Proceed to Step 3, page 105.

**Table F-1. Resistance values for determining RTD type**

Wire colors	Resistance if RTD is platinum	Resistance if RTD is copper	Resistance if RTD is open
Violet to orange	110 $\Omega$ at ambient temperature (70°F)	Open (infinite resistance)	Open (infinite resistance)
Violet to yellow	110 $\Omega$ at ambient temperature (70°F)	110 $\Omega$ at ambient temperature (70°F)	Open (infinite resistance)
Orange to yellow	0-10 $\Omega$	Open (infinite resistance)	-

### Step 3 Installing the RFT9739 transmitter

**⚠ WARNING**

**Hazardous voltage can cause severe injury or death.**

Shut off power before disconnecting the transmitter.

Follow these instructions to mount and wire the new RFT9739 transmitter:

- a. Mount the RFT9739 transmitter in accordance with the instructions in **Chapter 3**, page 11.
- b. Connect power-supply wiring and ground wires to the RFT9739 transmitter in accordance with the instructions in **Chapter 4**, page 17.
- c. Connect the flowmeter and output wiring from the old transmitter to the appropriate terminals on the RFT9739 transmitter.
  - **Figure F-1** shows the terminals on a Model RFT9739
  - Refer to **Figure F-2** and **Table F-2** for a Model RE-01
  - Refer to **Figure F-3** and **Table F-3** for a Model RFT9712
  - Refer to **Figure F-4** and **Table F-4** for a Model RFT9729
- d. If the sensor has a copper RTD, temperature lead length compensation is necessary for proper operation.
  - Connect the orange and yellow wires at the sensor end, to sensor terminal 4.
  - Alternatively, if the sensor is not easily accessible, and the cable that connects the sensor and transmitter is 50 feet (15 meters) or less, install a jumper between RFT9739 transmitter terminals CN1-B6 and CN1-B4.
- e. Proceed to Step 4, page 109.

**Figure F-1. RFT9739 terminals**

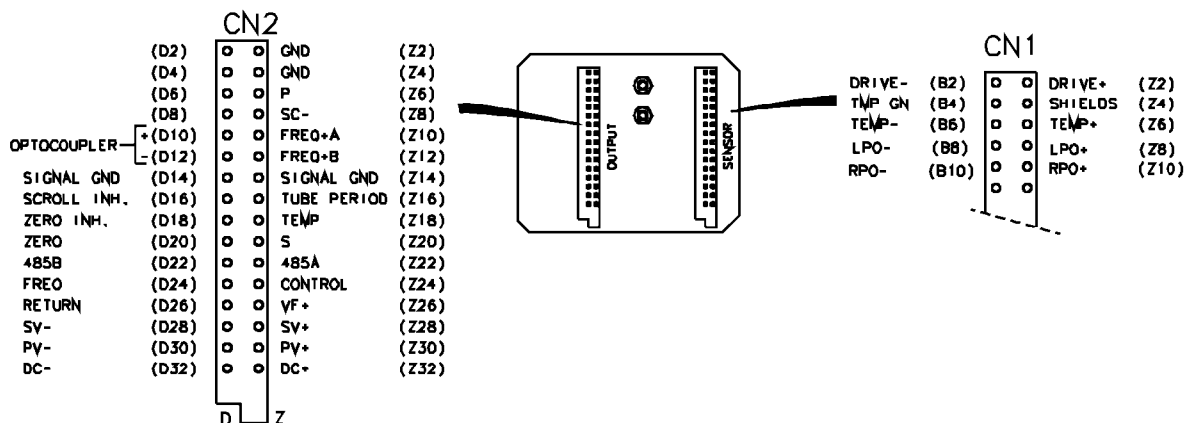

Figure F-2. RE-01 Remote Electronics Unit terminals

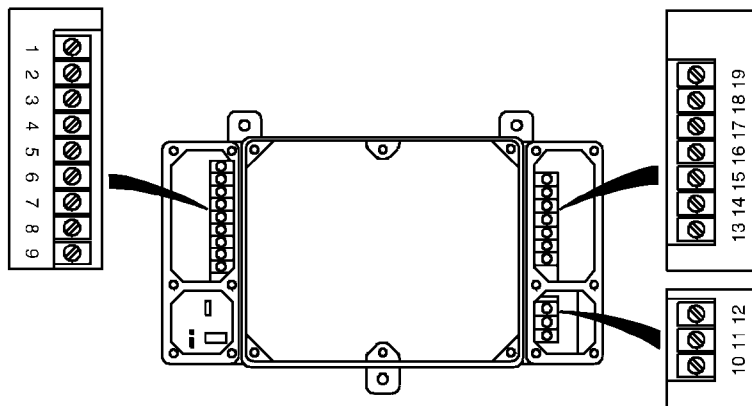

Table F-2. RE-01 to RFT9739 terminal conversions

Take the wire from RE-01 terminal number:	...and connect it to RFT9739 terminal number	Wire color (Micro Motion color-coded cable)	Function
1	CN1-Z2	Brown	Drive +
2	CN1-B2	Red	Drive -
3	CN1-B6	Orange	Temperature -
4	No connection	-	-
5	No connection	-	-
6	CN1-B4	Yellow <sup>[1]</sup>	Temperature lead length compensation
7	CN1-Z8	Green	Left pickoff +
8	CN1-Z10	Blue	Right pickoff +
9	CN1-Z6	Violet	Temperature +
10	See RFT9739 power-supply wiring and grounding instructions ( <b>Chapter 4</b> )		
11			
12			
13	CN2-D14 or CN2-Z14	-	Signal ground
14	CN2-Z26	-	VF +
15	No connection	-	-
16	CN2-D30	-	PV -
17	CN2-Z30	-	PV +
18	CN2-D26	-	Return
19	CN2-D24	-	Freq

<sup>[1]</sup>Shield wire from orange/violet pair.

Figure F-3. RFT9712 Remote Flow Transmitter terminals

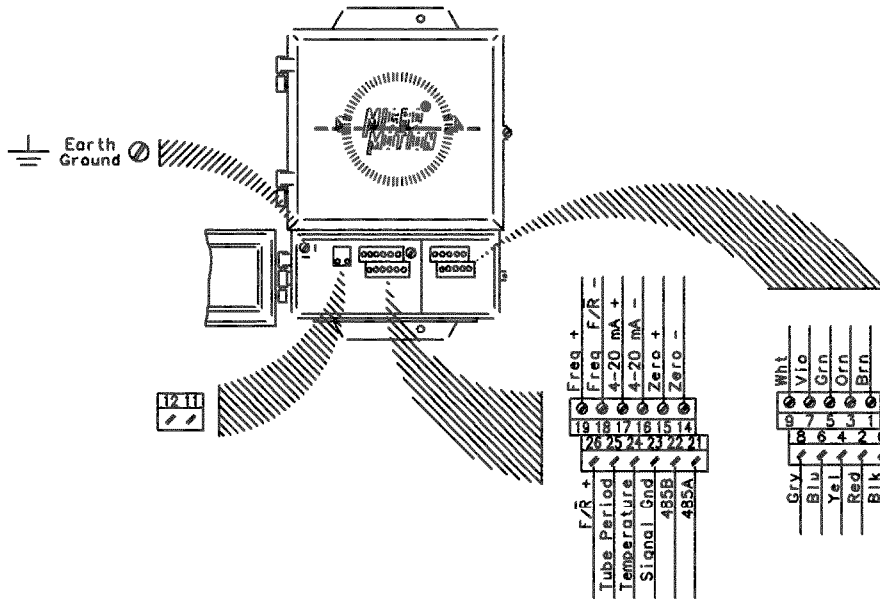

Table F-3. RFT9712 to RFT9739 terminal conversions

Take the wire from RFT9712 terminal number:	...and connect it to RFT9739 terminal number	Wire color (Micro Motion color-coded cable)	Function
0	CN1-Z4	Black <sup>[1]</sup>	Shields
1	CN1-Z2	Brown	Drive +
2	CN1-B2	Red	Drive -
3	CN1-B6	Orange	Temperature -
4	CN1-B4	Yellow <sup>[2]</sup>	Shield (Temperature lead length compensation)
5	CN1-Z8	Green	Left pickoff +
6	CN1-Z10	Blue	Right pickoff +
7	CN1-Z6	Violet	Temperature +
8	CN1-B10	Gray	Right pickoff -
9	CN1-B8	White	Left pickoff -
10	See RFT9739 power-supply wiring and grounding instructions ( <b>Chapter 4</b> )		
11			
12			
14	CN2-D26	-	Return
15	CN2-D20	-	Zero +
16	CN2-D30	-	PV -
17	CN2-Z30	-	PV +
18	CN2-D26	-	Return
19	CN2-D24	-	Freq +
21	CN2-Z22	-	485A
22	CN2-D22	-	485B
23	CN2-D14	-	Signal ground
24	CN2-Z18	-	Temperature
25	CN2-Z16	-	Tube period
26	CN2-Z24	-	Control

<sup>[1]</sup>Combined shields from brown/red, green/white, and gray/blue pairs

<sup>[2]</sup>Shield wire from orange/violet pair.

Figure F-4. RFT9729 Remote Flow Transmitter terminals

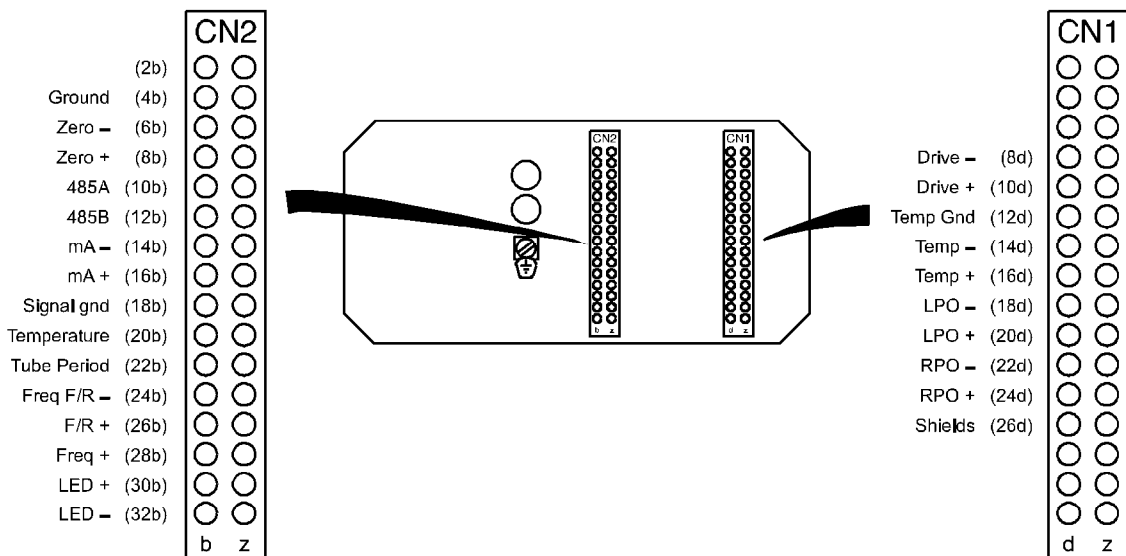

Table F-4. RFT9729 to RFT9739 terminal conversions

Take the wire from RFT9729 terminal number:	...and connect it to RFT9739 terminal number	Wire color (Micro Motion color-coded cable)	Function
CN1-8d	CN1-B2	Red	Drive -
CN1-10d	CN1-Z2	Brown	Drive +
CN1-12d	CN1-B4	Yellow <sup>[1]</sup>	Shield (Temperature lead length compensation)
CN1-14d	CN1-B6	Orange	Temperature -
CN1-16d	CN1-Z6	Violet	Temperature +
CN1-18d	CN1-B8	White	Left pickoff -
CN1-20d	CN1-Z8	Green	Left pickoff +
CN1-22d	CN1-B10	Gray	Right pickoff -
CN1-24d	CN1-Z10	Blue	Right pickoff +
CN1-26d	CN1-Z4	Black <sup>[2]</sup>	Shields
CN2-2d or 6z CN2-2b CN2-2z or 4bdz <sup>[3]</sup>	See RFT9739 power-supply wiring and grounding instructions (Chapter 4)		
CN2-6b	CN2-D26	-	Return
CN2-8b	CN2-D20	-	Zero +
CN2-10b	CN2-Z22	-	485A
CN2-12b	CN2-D22	-	485B
CN2-14b	CN2-D30	-	PV -
CN2-16b	CN2-Z30	-	PV +
CN2-18b	CN2-D14	-	Signal ground
CN2-20b	CN2-Z18	-	Temperature
CN2-22b	CN2-Z16	-	Tube period
CN2-24b	CN2-D26	-	Return
CN2-26b	CN2-Z24	-	Control
CN2-28b	CN2-D24	-	Freq

<sup>[1]</sup>Shield wire from orange/violet pair.

<sup>[2]</sup>Combined shields from brown/red, green/white, and gray/blue pairs

<sup>[3]</sup>Terminal CN2-2z is typically used for AC power-supply grounding. Alternative terminals available for this purpose are 4b, 4d, and 4z.

## Step 4 Characterizing sensors with copper RTDs

**⚠ CAUTION**

**Failure to characterize a sensor with a copper RTD will cause measurement error.**

If the sensor has a copper RTD, the flow calibration factor programmed into the transmitter must be modified to ensure accurate flow measurement.

Replace the second decimal point in the flow calibration factor with the letter "c".

Example:  
Calibration factor with platinum RTD: 63.1905.13  
Calibration factor with copper RTD: 63.1905c13

Use the procedures in one of the following manuals to characterize the sensor for flow, or see AMS on-line help:

- Using the HART Communicator with Micro Motion Transmitters
- Using ProLink Software with Micro Motion Transmitters
- Using Modbus Protocol with Micro Motion Transmitters

When entering the flow calibration factor, replace the second decimal point with the letter "C", if the sensor has a copper RTD, as shown in the example above. If the sensor has a platinum RTD, do not use a letter in place of the decimal point.





# Return Policy

## General guidelines

Micro Motion return procedures must be followed for you to meet the legal requirements of applicable U.S. Department of Transportation (DOT) regulations. They also help us provide a safe working environment for our employees. Failure to follow these requirements will result in your equipment being refused delivery.

To return equipment, contact the Micro Motion Customer Service Department for return procedures and required documentation:

- In the U.S.A., phone **1-800-522-6277** or **1-303-530-8400** between 6:00 a.m. and 5:30 p.m. (Mountain Standard Time), Monday through Friday, except holidays.
- In Europe, phone **+31 (0) 318 549 549**, or contact your local sales representative.
- In Asia, phone **(65) 777-8211**, or contact your local sales representative.

Information on return procedures and forms are also available on our Web site, at [www.micromotion.com](http://www.micromotion.com).

## New and unused equipment

Only equipment that has not been removed from the original shipping package will be considered new and unused. New and unused equipment includes sensors, transmitters, or peripheral devices which:

- Were shipped as requested by the customer but are not needed, or
- Were shipped incorrectly by Micro Motion.

## Used equipment

All other equipment is considered used. This equipment must be completely decontaminated and cleaned before being returned. Document all foreign substances that have come in contact with the equipment.



# Index

Page numbers in **bold** indicate illustrations.

- About this manual 1
- Accuracy 83
- Agency approvals
  - approved areas 88
  - hazardous area installation 3
  - order an approved transmitter 91
- Ambient temperature limits 87
- AMS 4
  - connecting to transmitter 29
  - zeroing procedure 65
- API gravity 86
- Approvals. See agency approvals
- Asset Management Solutions 4. See also AMS
  
- BASIS sensor. See F-Series
- Baud rate
  - communication configuration
    - using display 62
    - using switches 5, 9
- Bell 202
  - communication configuration
    - using display 63
    - using switches 5, 9
  - communication output specification 85
  - multidrop network 56, **57**
  
- Cable
  - gland
    - order with transmitter 91
  - installation guidelines 22
  - sensor wiring 22-24
  - wiring instruction manuals 92
- Calibration 4
  - master reset default values 80
  - security modes 6
- CE
  - EMC directive 1, **88**
  - low-voltage directive 1
    - power supply options 87
    - wiring guidelines 17
  - order a transmitter 91
- CENELEC
  - approved areas 88
  - hazardous area installations 4
  - installation guidelines 11
  - order an approved transmitter 91
- Characterization 4
  - copper RTD 109
  - master reset default values 80
  - security mode 8 7
  - security modes 6, 8
  
- CMF sensor. See ELITE sensor 23
- Communication configuration
  - master reset default values 80
  - mode 61-63
  - switches **5**
  - using display 60-63
  - using switches 9
- Communication output specification 85
- Conduit fitting
  - order with transmitter 91
- Configuration 4
- Control output 40-43
  - fault indication 86
  - open collector mode 41, **42**
  - specification 85
  - wiring **40**
- CSA
  - approved areas 88
  - hazardous area installation 3
  - instruction manual 92
  - order an approved transmitter 91
- Custody transfer event registers 64
  - security mode 8 7-8
- Customer service 81
- Cutoff 86
  
- D, DL, DT sensor
  - accuracy with 83
  - copper RTD 109
  - repeatability with 83
  - wiring
    - D, DL sensor **23**
    - DT sensor **24**
- Damping specification 86
- Data bits
  - communication configuration
    - using display 63
    - using switches 5, 9
  - master reset default values 80
- Default characterization and configuration values 80
- DH sensor. See D sensor
- Diagnostic messages 69-76
  - "burst mode" 76
  - "cal in progress" 76
  - "dens overrng" 74-75
  - "drive overrng" 74-75
  - "EPROM error" 73
  - "error cleared" 76
  - "event on" 76
  - "freq overrange" 74-75
  - "input overrng" 74-75

## Index continued

- "mA fixed" 76
- "mA saturated" 74-75
- "Msg" 59
- "not configured" 73
- "power reset" 76
- "RAM error" 73
- "RTI error" 73
- "security breach" 76
- "sensor error" 74-75
- "slug flow" 74-75
- "temp overrange" 74-75
- "xmtr failed" 73
- "zero error" 76
- Display 60-63
  - communication configuration 61-63
  - custody transfer event registers 64
  - process variables mode 60
  - screens 60
  - security mode 8 7-8
  - specifications 87
- DL sensor. See D sensor
- DMS Density Monitoring System
  - and frequency/pulse output 30
  - wiring 44
- Downscale
  - fault indication 69, 86
  - mA output scaling 9
- DRT Digital Rate Totalizer
  - wiring 45
- DT sensor. See D sensor
- Dual-channel frequency output 36
- Effect. See Environmental effects; Pressure compensation
- ELITE sensor
  - accuracy with 83
  - repeatability with 83
  - wiring 23
- EMC. See CE
- Environmental effects on sensor and transmitter 88
- Environmental limits 87
- External zero
  - external switch wiring 54
  - zeroing procedure 65
- Fault outputs
  - mA output scaling 9
  - specification 86
  - troubleshooting with 69
- Flowmeter cable 22
  - DT sensors 24
  - ELITE sensors 23
  - F-Series, D, DL sensors 23
  - instruction manual 92
- FMS-3 Flow Monitoring System
  - wiring 46
- Frequency/pulse output 30-35
  - constant current 32, 32
  - default configuration 31
  - fault indication 69
  - increased current 31, 31
  - open collector mode 33, 34
- security mode 8 7
  - specification 84
  - test 72, 87
  - wiring 31
- F-Series sensor
  - accuracy with 83
  - repeatability with 83
  - wiring 23
- Functional specifications 84-88
- Fuses 21, 87
- Grounding 17, 19-20
- Handbook 44
  - security mode 8 7
- HART Communicator. See also HART protocol
  - connecting to transmitter 29, 29
  - diagnostic messages 70
  - fast key codes 99
  - instruction manual 92
  - interrogation with 70-72
  - master reset 79
  - menu trees 97-99
  - specifications
    - communication output 85
    - troubleshooting with 70-72
- HART protocol. See also HART Communicator
  - communication configuration
    - using display 60-63
    - using switches 5, 9
  - mA outputs 27-29
  - master reset default values 80
  - multidrop network
    - Bell 202 56
    - RS-485 55
- Hazardous areas
  - agency approvals 88
  - CENELEC standards 4
  - installing in 3
  - order an approved transmitter 91
- Humidity limits 87
- Identifying transmitter version 101
- Initialization 59
- Instruction manuals
  - list of 92
- Intrinsically safe installations 3
  - grounding 17
  - wiring guidelines 17
- Jumpers
  - jumper J10 37, 38
  - jumper JP1 37, 38
  - setting for VDE 37-38
- Lead length compensation
  - temperature return wiring terminal 23
- Low-flow cutoff specification 86
- Low-voltage directive. See CE

## Index continued

- mA outputs 27-29
  - AMS modem 29
  - Bell 202 multidrop network 56
  - fault indication 69
  - HART Communicator **29**
  - master reset default value 80
  - performance **27**
  - ProLink PC interface **29**
  - rangeability specification 84
  - scaling 9
  - security mode 8 7
  - specification 84
  - switches 5
  - temperature effect on 88
  - test 72, 87
  - trim 72
  - wiring 27-29, **28**
- Master reset
  - default characterization and configuration values 80
  - procedure 79
  - security mode 8 7-8
- Menu trees for HART Communicator 97-99
  - fast key codes 99
- Message display. See Diagnostic messages
- Modbus protocol
  - communication configuration 9
    - using display 60-63
    - using switches 5, 9
  - custody transfer event registers 64
  - instruction manual 92
  - master reset default values 80
  - multidrop network 55-56
- Model 3300
  - wiring **49**
- Model 3350
  - wiring **50**
- Mounting 11-15
- Multidrop network
  - Bell 202 56, **57**
  - RS-485 55, **56**
- NAMUR standard 27
- National Institute of Standards and Technology
  - custody transfer event registers 64
  - security mode 8 7
- Network. See Multidrop network
- NFC Net Flow Computer
  - wiring **47**
- NIST. See National Institute of Standards and Technology
- NOC Net Oil Computer
  - AC-powered wiring **48**
  - DC-powered wiring **48**
- Nominal resistance range for flowmeter circuits 78
- Optional display. See Display
- Optocoupler output 39
- Ordering information 91-92
- Outputs
  - control 40-43, **40**
    - open collector mode 41, **42**
  - dual-channel frequency 36
  - fault indication 69
  - frequency 30-39
    - frequency/pulse 30-35
      - constant current 32, **32**
      - default configuration 31
      - increased current 31, **31**
      - open collector mode 33, **34**
      - test 72
      - wiring **31**
  - mA 27-29
    - Bell 202 multidrop network 56, **57**
    - performance **27**
    - rangeability 84
    - scaling 9
    - switches 5, 9
    - temperature effect on 88
    - test 72, 87
    - trim 72
  - NAMUR standard 27
  - optocoupler 39
  - specifications 84-86
  - terminals **26**
  - test 72, 87
  - wiring 25-58
- Parity 5
  - communication configuration 9
    - using display 62
    - using switches 5, 9
- Performance specifications 83
- Peripheral device wiring 44
  - DMS Density Monitoring System **44**
  - DRT Digital Rate Totalizer **45**
  - FMS-3 Flow Monitoring System **46**
  - instruction manual 92
  - Model 3300 **49**
  - Model 3350 **50**
  - NFC Net Flow Computer **47**
  - NOC Net Oil Computer
    - AC-powered **48**
    - DC-powered **48**
- Physical layer
  - communication configuration 9
    - using display 63
    - using switches 5
  - master reset default values 80
- PI 4-20 Process Indicator
  - and frequency/pulse output 30
- Power supply 17-21
  - changing 21
  - fuses 21
  - pressure transmitter 51, **53**
    - specification 87
  - troubleshooting 77
  - wiring 17-18, **18**,
    - grounding 17
    - low-voltage directive 17
- Pressure compensation 51
  - input specification 86
- Pressure transmitter 51-53
- Primary output 27
- Process measurement 68
- Process variables mode 60

## Index continued

- ProLink program
  - communication configuration
    - using switches **5**
  - connecting to transmitter **29, 29**
  - custody transfer event registers **64**
  - diagnostic messages **70**
  - instruction manual **92**
  - interrogation with **70-72**
  - master reset **79-80**
  - troubleshooting with **70-72**
- Rack mounting
  - about **1**
  - connectors **15**
  - dimensions **12-13**
- Rangeability
  - mA outputs **84**
- Repeatability **83**
- Reset inhibit **58**
- Return policy **111**
- RFT9739 transmitter
  - about **1**
  - characterization and calibration **4**
  - identify version **101**
  - model number **91**
  - ordering a transmitter **91**
  - specifications **83-89**
  - version **101**
  - wiring
    - Bell 202 network **57**
    - connections to sensor and transmitter **22-24**
      - DT sensors **24**
      - ELITE sensors **23**
      - F-Series, D, DL sensors **23**
    - diagrams
      - peripheral devices **44**
    - dual-channel frequency output **36**
    - output **25-58**
      - control **40-43, 40, 42**
      - dual-channel frequency **36**
      - frequency **30-39**
      - frequency/pulse **30-35**
      - mA **27-29**
      - optocoupler **39**
    - pressure transmitter
      - analog output **52**
      - digital communication **53**
      - external power, analog input **53**
    - RS-485 network **56**
- RS-485
  - communication configuration
    - using display **63**
    - using switches **5, 9**
  - communication output specification **85**
  - multidrop network **55, 56**
- Scroll and Reset buttons
  - about **1**
  - security modes **6-8**
  - totalizer reset **67**
  - using **60**
  - zeroing with **65-66**
- Scroll inhibit **58**
- Secondary output **27**
- Security
  - breach **7**
  - custody transfer event registers **64**
  - modes **6-8**
    - security mode **8 7-8**
  - switches **5, 5**
  - wiring **58, 58**
- Slug flow
  - fault indication **74**
  - specification **86**
- Slug flow fault indication **75**
- Software trees. See Menu trees for HART Communicator
- Specifications **83-89**
  - accuracy **83**
  - damping **86**
  - display **87**
  - environmental effects **88**
  - environmental limits **87**
  - fault outputs **86**
  - hazardous area approvals **88**
  - input for pressure **86**
  - low-flow cutoff **86**
  - output signals **84**
  - output testing **87**
  - power supply **87**
  - repeatability **83**
  - slug-flow inhibit **86**
  - weight **89**
- Startup **59-68**
  - custody transfer event registers **64**
  - display **60-63**
    - communication configuration **61-63**
    - process variables mode **60**
    - screens **60**
  - initialization **59**
  - "Msg" indicator **59**
  - process measurement **68**
  - totalizer control **67**
  - zeroing **65-66**
    - additional information **66**
    - diagnosing zero failure **66**
    - procedure **65**
- Stop bits **5**
  - communication configuration
    - using display **62**
    - using switches **5**
- Switches **5, 5**
  - communication configuration **9**
  - mA output scaling **9**
  - master reset **79**
  - security **6-8**

## Index continued

- Temperature
  - effect on transmitter 88
  - limits 87
- Terminals. See also Wiring
  - Bell 202 network 57
  - ELITE sensors **23**
  - F-Series sensors **23**
  - Model D sensors **23**
  - Model DL sensors **23**
  - Model DT sensors **24**
  - output **26**
    - control 40
    - dual-channel frequency 36
    - frequency/pulse 30
    - mA 28-29
    - optocoupler 39
    - peripheral devices 44
  - power supply 23
  - remote-zero 54
  - RS-485 network 55
  - security wiring 58, **58**
  - sensor
    - DT **24**
    - ELITE **23**
    - F-Series, D, DL **23**
- Test
  - mA output 72
  - outputs 72
- Totalizer control 67
  - reset 67
  - security 6
  - start 67
  - stop 67
- Totalizer reset
  - security 6
- Trim
  - mA output 72
- Troubleshooting 69
  - customer service 81
  - diagnostic messages
    - "burst mode" 76
    - "cal in progress" 76
    - "dens overrng" 74-75
    - "drive overrng" 74-75
    - "EPROM error" 73
    - "error cleared" 76
    - "event on" 76
    - "freq overrange" 74-75
    - "input overrng" 74-75
    - "mA fixed" 76
    - "mA saturated" 74-75
    - "not configured" 73
    - "power reset" 76
    - "RAM error" 73
    - "RTI error" 73
    - "security breach" 76
    - "sensor error" 74-75
    - "slug flow" 74-75
    - "temp overrange" 74-75
    - "xmtr failed" 73
    - "zero error" 76
  - diagnostic tools 69-70
  - display 73-76
  - fault outputs 69
  - frequency/pulse output test 72
  - general guidelines 69
  - HART Communicator 70-72
  - mA outputs test 72
  - mA outputs trim 72
  - master reset 79-80
  - open circuits 78
  - power supply 77
  - ProLink program 70-72
  - wiring 78
  - zero failure 66, 76
- UL
  - approved areas 88
  - hazardous area installation 3
  - instruction manual 92
  - order an approved transmitter 91
- Upscale
  - fault indication 69, 86
  - mA output scaling 9
- VDE 37-38
- Version 3 transmitter
  - identifying 101
- Vibration limits 87
- Voltage level 37-38
- Weight 89
- Wiring
  - diagrams
    - AMS modem 29
    - Bell 202 network **57**
    - control output **40**
      - open collector mode **42**
    - DMS Density Monitoring System **44**
    - DRT Digital Rate Totalizer **45**
    - dual-channel frequency output **36**
    - FMS-3 Flow Monitoring System **46**
    - frequency/pulse outputs
      - constant current **32**
      - default configuration **31**
      - increased current **31**
      - open collector **34**
    - HART Communicator **29**
    - mA outputs **28**
    - Model 3300 **49**
    - Model 3350 **50**
    - NFC Net Flow Computer **47**
    - NOC Net Oil Computer
      - AC-powered **48**
      - DC-powered **48**
    - pressure transmitter
      - analog output **52**
      - digital communications **53**
      - external power **53**

## Index continued

- ProLink PC interface **29**
- remote-zero switch **54**
- RS-485 network **56**
- security **58**
- sensors
  - DT sensor **24**
  - ELITE **23**
  - ELITE sensor **23**
  - F-Series, D, DL sensor **23**
- grounding 17
- instruction manuals 92
- output 25-58
  - general guidelines 25
- power supply 17-18
- pressure transmitter 51-53
  - sensor **23**
  - sensor connections 22-24
    - diagrams **24**
    - general guidelines 17
  - troubleshooting 78
- Zero button
  - security modes 6
- Zero failure 66
- Zeroing 65-66
  - failure 66, 76
  - security 5
  - security modes 6
- Zeroing procedure 65





Visit us on the Internet at [www.micromotion.com](http://www.micromotion.com)

**Micro Motion Europe**

Groeneveldselaan 8  
3903 AZ Veenendaal  
The Netherlands  
Tel +31 (0) 318 549 549  
Fax +31 (0) 318 549 559

**Micro Motion Asia**

1 Pandan Crescent  
Singapore 128461  
Republic of Singapore  
Tel (65) 777-8211  
Fax (65) 770-8003

**Micro Motion Inc. USA  
Worldwide Headquarters**

7070 Winchester Circle  
Boulder, Colorado 80301  
Tel (303) 530-8400  
(800) 522-6277  
Fax (303) 530-8459

**Micro Motion Japan**

Shinagawa NF Bldg. 5F  
1-2-5, Higashi Shinagawa  
Shinagawa-ku  
Tokyo 140-0002 Japan  
Tel (81) 3 5769-6803  
Fax (81) 3 5769-6843

# Micro Motion

**FISHER-ROSEMOUNT™ Managing The Process Better.™**

©2000, Micro Motion, Inc.  
All rights reserved  
P/N 3002192, Rev. F (2/00)

 recycled paper

Invensys Ex. 2006  
Micro Motion v. Invensys IPR 2014-00393, page 130

INVENSYS0111683