

- [54] **METHOD AND STRUCTURE FOR FLOW MEASUREMENT**
- [75] Inventor: **James E. Smith, Boulder, Colo.**
- [73] Assignee: **Micro Motion, Inc., Boulder, Colo.**
- [21] Appl. No.: **348,071**
- [22] Filed: **Feb. 11, 1982**

**Related U.S. Patent Documents**

Reissue of:

- [64] Patent No.: **4,187,721**
- Issued: **Feb. 12, 1980**
- Appl. No.: **926,468**
- Filed: **Jul. 20, 1978**

U.S. Applications:

- [63] Continuation-in-part of Ser. No. 818,475, Jul. 25, 1977, abandoned.
- [51] Int. Cl.<sup>3</sup> ..... **G01F 1/86**
- [52] U.S. Cl. .... **73/861.38; 73/434**
- [58] Field of Search ..... **73/32 A, 434, 505, 861.18, 73/861.35, 861.37, 861.38**

[56] **References Cited**

**U.S. PATENT DOCUMENTS**

2,624,198	1/1953	Pearson .	
2,635,462	4/1953	Poole et al. ....	73/32
2,753,173	7/1956	Barnaby et al. ....	264/1
2,754,676	7/1956	Poole et al. ....	73/32
2,804,771	9/1957	Brown .....	73/228
2,811,854	11/1957	Powers .	
2,813,423	11/1957	Altfillisch et al. .	
2,821,084	1/1958	Altfillisch et al. .	
2,831,349	4/1958	Altfillisch et al. .	
2,834,209	5/1958	Jones et al. .	
2,865,201	12/1958	Roth .	
2,877,649	3/1959	Powers .	
2,889,702	6/1959	Brooking .....	73/32
2,897,672	8/1959	Glasbrenner et al. ....	73/228
2,914,945	12/1959	Cleveland .	
2,923,154	2/1960	Powers et al. .	
2,934,951	5/1960	Li .	
2,943,476	7/1960	Bernstein .....	73/32
2,943,487	7/1960	Potter .	
2,956,431	10/1960	Westerheim .....	73/32
3,039,310	6/1962	Copland et al. ....	73/434

3,044,302	7/1962	Knauth .....	73/434
3,049,917	8/1962	Alspach et al. .	
3,049,919	8/1962	Roth .....	73/228
3,080,750	3/1963	Wiley et al. .	
3,087,325	4/1963	Roth .....	73/3
3,096,646	7/1963	Peirce .....	73/228
3,108,475	10/1963	Henderson .	
3,132,512	5/1964	Roth .	
3,138,955	6/1964	Uttley .	
3,164,017	1/1965	Karlby et al. .	
3,167,691	1/1965	Halista .....	317/157
3,218,851	11/1965	Sipin .	
3,232,110	2/1966	Li .	
3,251,226	5/1966	Cushing .....	73/861.63 X
3,261,205	7/1966	Sipin .	
3,276,257	10/1966	Roth .	
3,276,258	10/1966	Rowley .	
3,298,221	1/1967	Miller et al. ....	73/32
3,303,705	2/1967	Dostal .....	73/505
3,320,791	5/1967	Banks .....	73/32
3,329,019	7/1967	Sipin .	
3,339,400	9/1967	Banks .....	73/32
3,344,666	10/1967	Rilett .	
3,349,604	10/1967	Banks .....	73/32
3,350,936	11/1967	Li .	
3,355,944	12/1967	Sipin .	
3,385,104	5/1968	Banks .	
3,396,579	8/1968	Sourian .	
3,449,940	6/1969	Banks .....	73/32
3,449,941	6/1969	Banks .....	73/32
3,456,491	7/1969	Brockhaus .....	73/32
3,481,509	12/1969	Marhauer .	
3,485,098	12/1969	Sipin .	
3,533,285	10/1970	Dee .	
3,555,900	1/1971	Bauer et al. .	
3,575,052	4/1971	Lenker .	
3,584,508	6/1971	Shiba .	
3,589,178	6/1971	Germann .	
3,608,374	9/1971	Miller .	
3,613,451	10/1971	Scott .	
3,625,055	12/1971	LaFourcade .	
3,677,086	7/1977	Corey .	
3,688,574	9/1972	Arutunian et al. .	
3,728,893	4/1973	Janssen .....	73/32
3,740,586	6/1973	Banks et al. .	
3,762,217	10/1973	Hagen .	
3,839,915	10/1974	Schlitt .	
3,842,681	10/1974	Mumme .	
3,876,927	4/1975	Gee et al. .	
3,897,766	8/1975	Pratt, Jr. et al. .	
3,927,565	12/1975	Pavlin et al. .	

3,955,401 5/1976 Catherall ..... 73/32 A  
 4,051,723 10/1977 Head et al. .  
 4,056,976 11/1977 Hildebrand .  
 4,109,524 8/1978 Smith .  
 4,127,028 11/1978 Cox et al. .... 73/861.38

## FOREIGN PATENT DOCUMENTS

2249269 4/1974 Fed. Rep. of Germany .  
 2145387 2/1975 France .  
 32-6595 8/1957 Japan .  
 44-18531 8/1969 Japan .  
 46-19827 6/1971 Japan .  
 117091 5/1958 U.S.S.R. .  
 146982 4/1961 U.S.S.R. .  
 149900 11/1961 U.S.S.R. .  
 159678 12/1963 U.S.S.R. .  
 171651 5/1965 U.S.S.R. .  
 400838 10/1973 U.S.S.R. .  
 426170 4/1974 U.S.S.R. .  
 486247 9/1975 U.S.S.R. .

## OTHER PUBLICATIONS

A. Treatise; *Continuous Measurement of Unsteady Flow*,  
 by G. P. Katys, translated from the Russian by D. P.  
 Barrett, MacMillan Company, New York, 1964.

Primary Examiner—Jerry W. Myracle  
 Attorney, Agent, or Firm—Irons & Sears

[57]

## ABSTRACT

Apparatus and method for mass flow measurement utilizing a substantially "U" shaped conduit mounted in a cantilever manner at the legs thereof, [means for oscillating the conduit, and means for measuring] so that, when the conduit is oscillated, sensors mounted on the conduit can measure the Coriolis force by measurement of the force moment or the angular motion of the conduit around an axis substantially symmetrical to the legs of the conduit. The force moment is measured by sensing incipient movement around the axis, and generating and measuring a nulling force. In preferred embodiments, the oscillating means are mounted on a spring arm having a natural frequency substantially equal to that of the "U" shaped conduit, and in a particularly preferred [displacement] embodiment the measuring [means are sensors] sensors are mounted on the "U" shaped conduit and adapted to measure, with proper direction sense, the time differential between the leading and trailing portions of the "U" shaped conduit passing through the plane of the "U" shaped conduit at substantially midpoint of the oscillation thereof.

55 Claims, 14 Drawing Figures

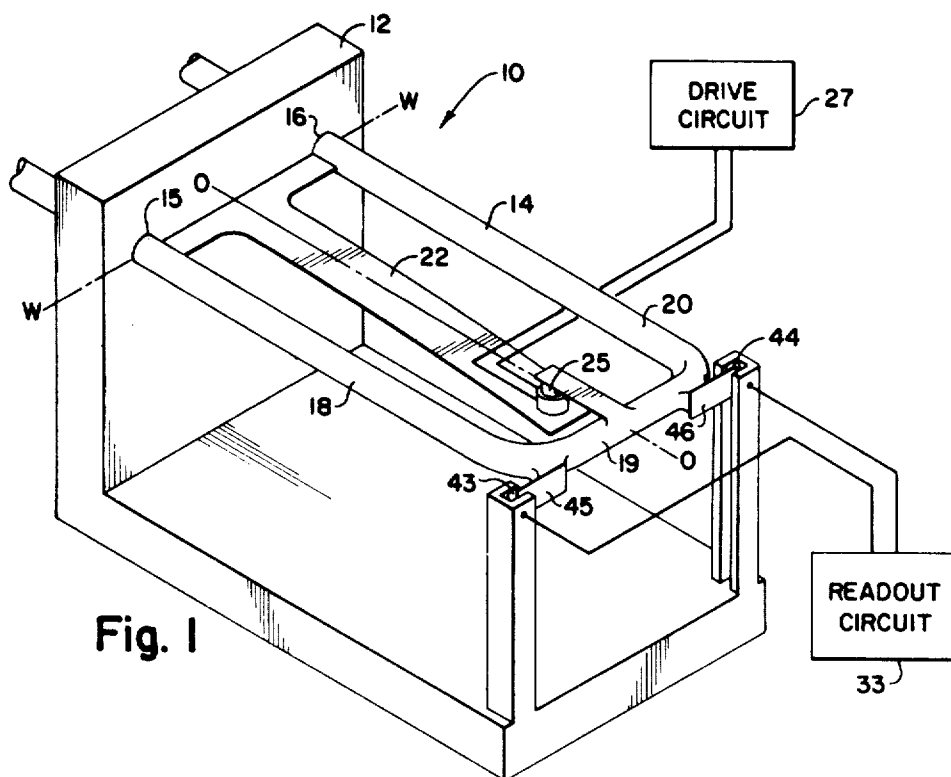

Fig. 1

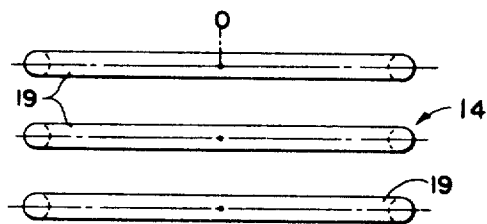

Fig. 2

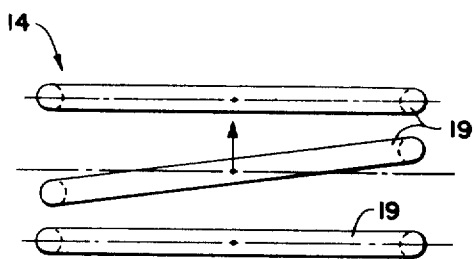

Fig. 3

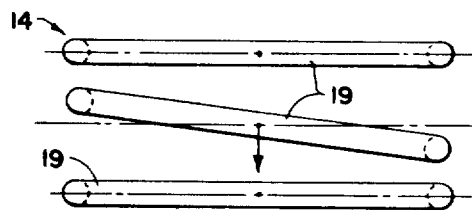
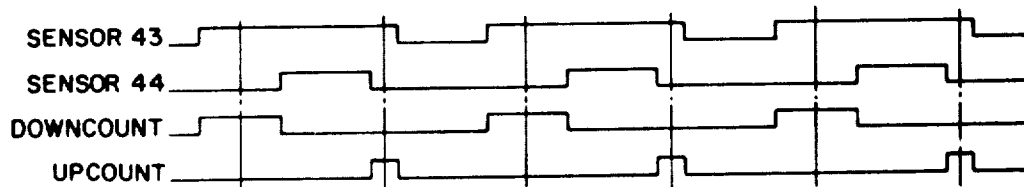
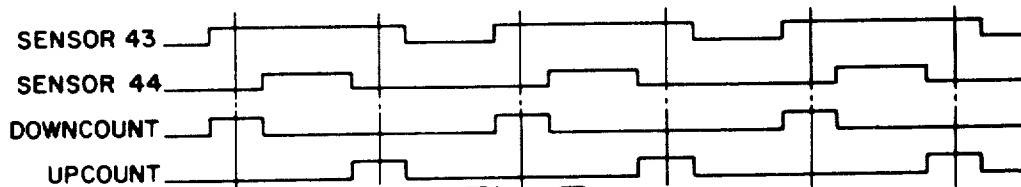
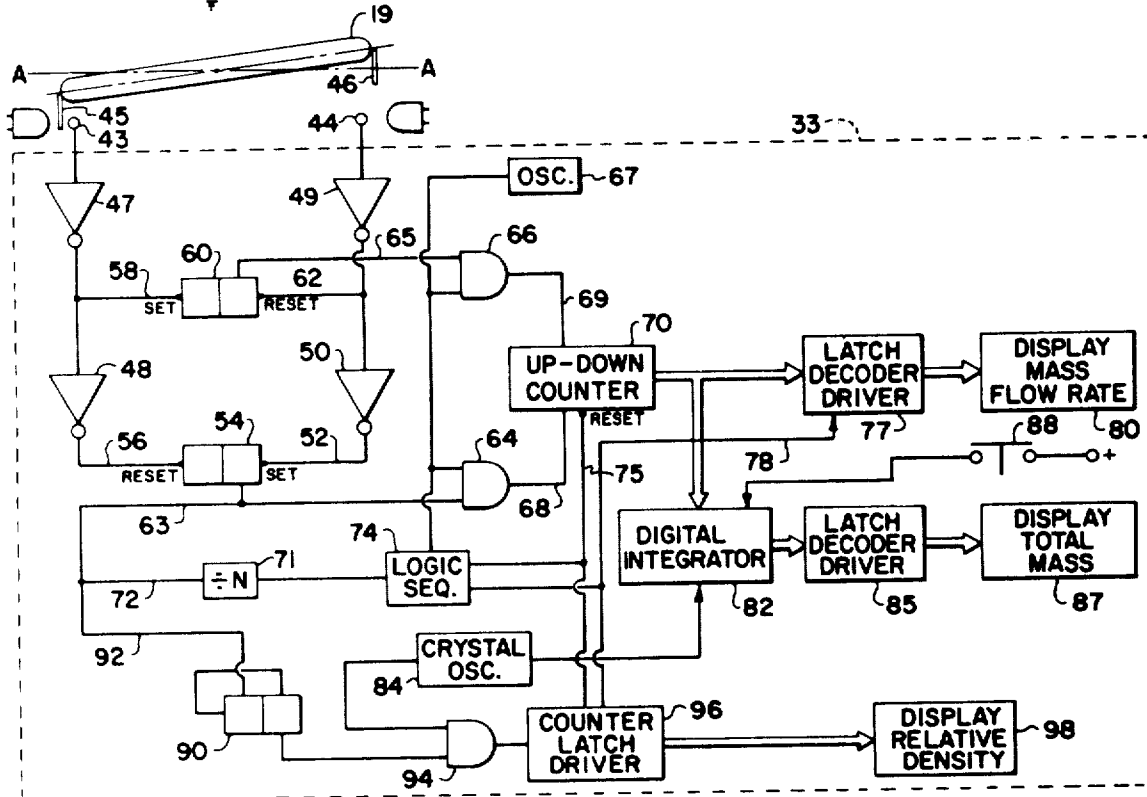
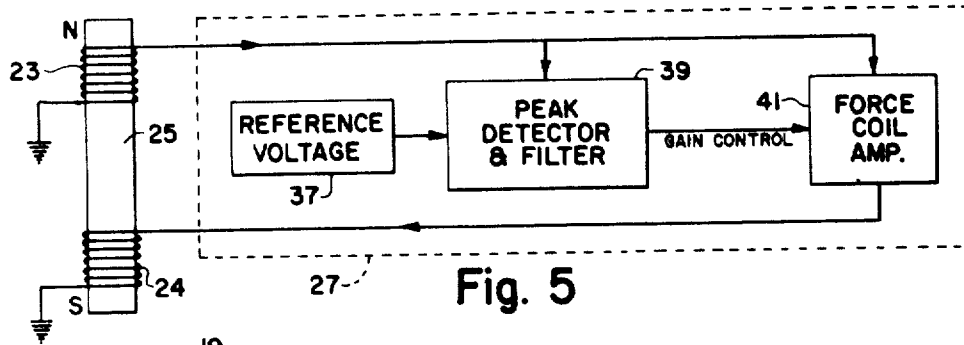

Fig. 4



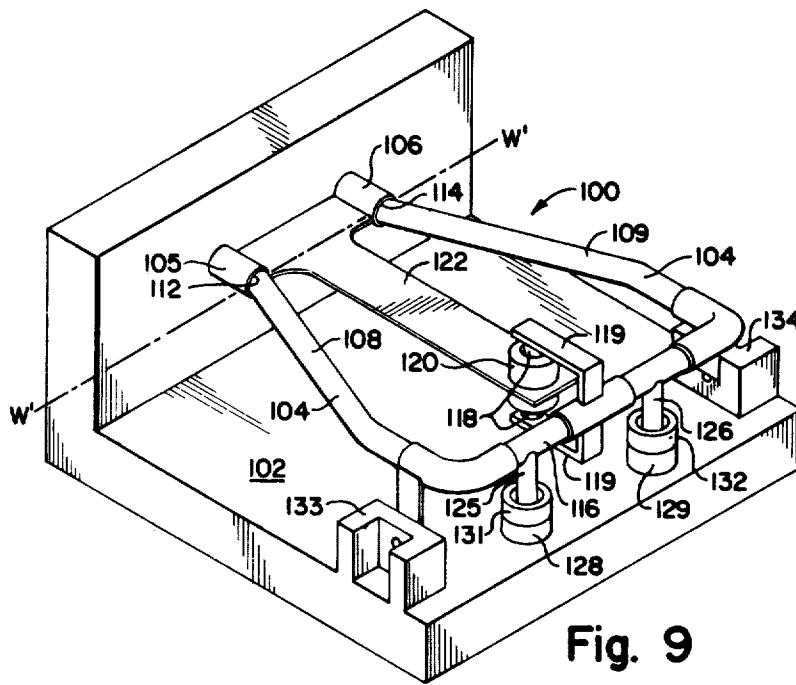

Fig. 9

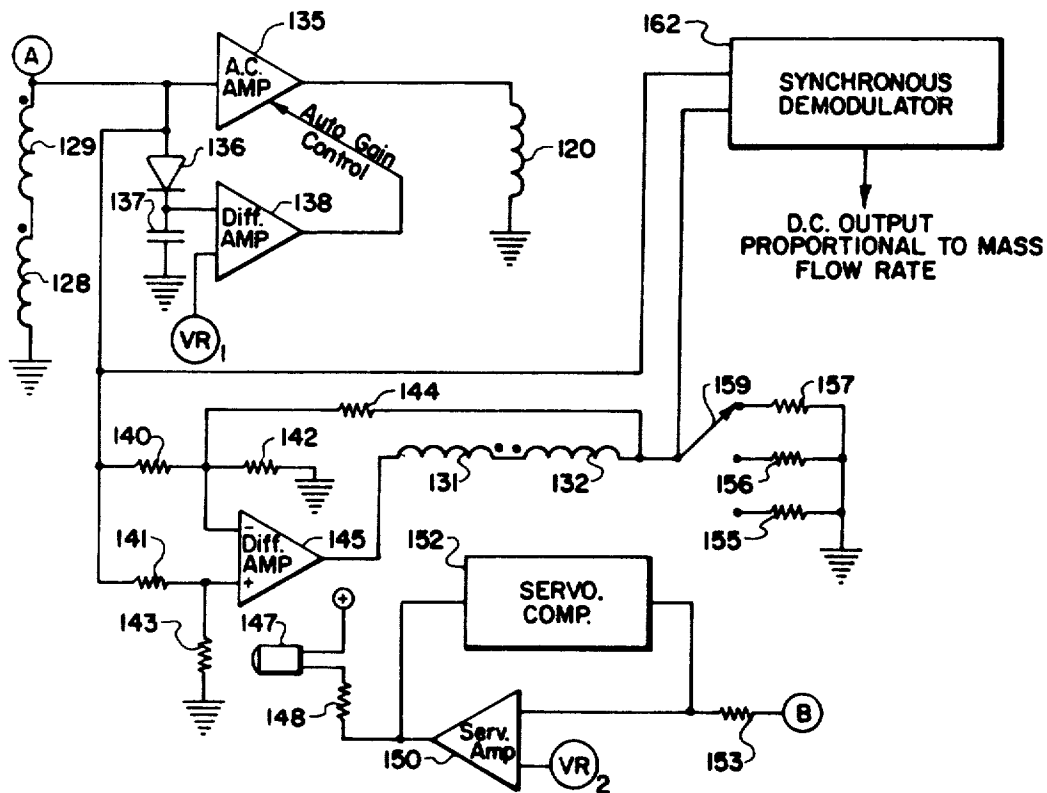

Fig. 10

# Explore Litigation Insights

Docket Alarm provides insights to develop a more informed litigation strategy and the peace of mind of knowing you're on top of things.

## Real-Time Litigation Alerts



Keep your litigation team up-to-date with **real-time alerts** and advanced team management tools built for the enterprise, all while greatly reducing PACER spend.

Our comprehensive service means we can handle Federal, State, and Administrative courts across the country.

## Advanced Docket Research



With over 230 million records, Docket Alarm's cloud-native docket research platform finds what other services can't. Coverage includes Federal, State, plus PTAB, TTAB, ITC and NLRB decisions, all in one place.

Identify arguments that have been successful in the past with full text, pinpoint searching. Link to case law cited within any court document via Fastcase.

## Analytics At Your Fingertips



Learn what happened the last time a particular judge, opposing counsel or company faced cases similar to yours.

Advanced out-of-the-box PTAB and TTAB analytics are always at your fingertips.

## API

Docket Alarm offers a powerful API (application programming interface) to developers that want to integrate case filings into their apps.

## LAW FIRMS

Build custom dashboards for your attorneys and clients with live data direct from the court.

Automate many repetitive legal tasks like conflict checks, document management, and marketing.

## FINANCIAL INSTITUTIONS

Litigation and bankruptcy checks for companies and debtors.

## E-DISCOVERY AND LEGAL VENDORS

Sync your system to PACER to automate legal marketing.