

1984
NISSAN
300ZX

OWNER'S MANUAL

AMH00589

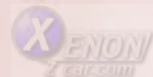

Honda Ex. 1008

A Word To NISSAN Owners

Thank you for choosing a NISSAN. We are sure you will be happy you did. This manual has been prepared to help you understand the operation and maintenance of your vehicle so that you may enjoy many miles of driving pleasure.

A Warranty Booklet supplements this Owner's Manual. It provides valuable information concerning the warranty on your vehicle, etc. Read the Owner's Manual and Warranty Booklet carefully and keep them in your glove box at all times.

Your dealer has the equipment and experience to service your vehicle. He is kept advised of every new technical development and you are his customer. Your DEALER/DATSUN dealer is the best place for you to take your vehicle for any kind of service.

To assist dealers in handling your needs, a number of Regional Offices are maintained throughout the United States and Canada. If you have a problem that has not been

handled to your satisfaction, follow the procedures outlined in your Warranty Booklet under the heading "Consumer Assistance".

OPERATION IN ANOTHER COUNTRY, STATE OR DISTRICT

When planning to travel in another country you should first find out if the octane rating of the gasoline available there is suitable for your vehicle's engine. Using gasoline with too low an octane rating may cause engine damage. Therefore, avoid taking your vehicle to areas where gasoline of the appropriate octane is not available. All models can be operated only with unleaded gasoline.

The laws and regulations for motor vehicle emission control and safety standards vary according to the country; therefore, vehicle specifications may differ.

In addition, laws and regulations of the state or local governments differ; therefore, some vehicle specifications may also be different.

When transferring the registration of any vehicle to another country, state or district, it may be necessary to modify the

vehicle to meet local laws and regulations. The vehicle must pass an inspection by the local authorities after it is modified. In addition, the vehicle may be required to complete other complicated procedures in order to transport and register the vehicle in another country, state or district.

When registered in another country, the following inconveniences may be encountered:

- Appropriate service may not be provided due to the non-availability of necessary parts, equipment or tools.
- A fuel that meets the appropriate specifications may not be available. The use of an inappropriate fuel could cause operational difficulties in the engine.
- Unleaded gasoline may be unavailable. The use of a leaded gasoline could cause deterioration in the catalyst performance.

When any vehicle is to be taken into another country, state or district and registered, its modifications, transportation and registration are the responsibility of the user. Always be sure to check local regulations before taking your vehicle into another country. Nissan is not responsible for any inconvenience that may result.

Contents

Because of the variety of options, components and features offered by NISSAN and your NISSAN/DATSUN dealer, the equipment described in this manual may or may not be identified as standard or optional and may or may not be applicable to your particular vehicle.

All information, specifications and illustrations in this manual are those in effect at the time of printing. NISSAN reserves the right to change specifications or design at any time without notice.

© 1983 NISSAN MOTOR CO., LTD.
TOKYO, JAPAN

Economy Hints	1-1
Before Driving Your NISSAN	2-1
Instruments And Controls	3-1
Starting And Operating	4-1
Comfort And Convenience Features ...	5-1
In Case Of Emergency	6-1
Emission Control Systems	7-1
Maintenance Schedule	8-1
Do-It-Yourself	9-1
Appearance And Interior Care	10-1
Specifications	11-1
Consumer Information	12-1
Index	13-1
Gas Station Information	14-1

Economy Hints



Normal driving saves fuel and money.



Severe driving wastes fuel and money.

Operational economy is one of the outstanding features of your NISSAN. By developing the following good driving habits even greater economy may be attained.

1. Do not pump the accelerator. Gently depress until the desired speed has been attained and then try to maintain that speed.
2. Always drive your vehicle in the gear which properly suits driving conditions.
3. Maintain moderate speeds on the highway. Speeds above 50 MPH (80 km/h) will considerably increase fuel consumption.
4. Maintain a safe distance behind other vehicles. Avoid sudden stops. This will reduce wear on brake linings and pads and save fuel, as extra fuel is required to accelerate back to driving speed.
5. Excessive engine revving while the vehicle is stopped increases fuel consumption.
6. Keep the tires at the recommended inflation pressures for longer tire life and fuel economy.
7. Keep your engine tuned-up and follow the recommended periodic maintenance schedule. This will increase the life of all parts and lower operating costs.
8. Check your tires regularly for abnormal wear. Wheels that are out of alignment cause the tires to drag, resulting in premature tire wear and additional fuel consumption.
9. Use the air conditioner only when necessary. When cruising at highway speeds, it is more economical to use the air conditioner and leave the windows closed to reduce drag.

Before Driving Your NISSAN

Familiarize yourself with all the NISSAN features and safe-driving procedures.

SAFETY CHECKS

Before driving your NISSAN, be sure to check all the safety items mentioned below.

BEFORE ENTERING THE VEHICLE

- Check to be sure that all windows and light lenses are clean.
- Visually inspect tires for their appearance and condition. Also check tire pressure for proper inflation.
- Check to be sure that area around vehicle is clear.
- Make sure that the hood, doors and rear hatch are closed securely.

- To prevent the battery from running down, avoid continuous use of the power unit such as the power seat, power window, etc. which consume a large amount of electric power when the engine is stopped.

AFTER ENTERING THE VEHICLE

- Lock all doors.
- Position seat and adjust head restraints.
- Adjust inside and outside mirrors.
- Fasten seat belts and ask all passengers to do likewise.
- Check the operation of lights, switches, horn and brakes.
- Check the operation of warning lights when key is turned to "ON" position.
- Adjust tilting steering wheel.
- Check to make sure all windows are clear from frost and fog.

BUCKLE-UP FOR SAFETY!

To help lessen the chance of injury and/or the severity of injury in accidents or sudden stops, NISSAN Motors urges that people riding in the vehicle be properly restrained at all times, using the seat belts provided.

IMPORTANT OWNER INFORMATION

Fluid levels such as engine oil, engine coolant, brake and clutch fluid, windshield washer, rear window washer fluid should be checked frequently, or at least whenever you refuel.

This is not only a good practice but is especially important to owners using "self-service" service stations. It is normal, especially in the case of engine oil and coolant, to have to add oil or coolant solution between recommended maintenance intervals. **Low or improper fluid levels can cause serious damage to your vehicle.** If frequent replenishment is required, take your vehicle to your NISSAN/DATSUN dealer or other competent service facility for necessary correction. Further details are described in "Do-It-Yourself".

KEY

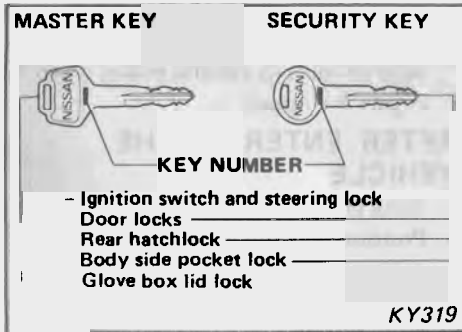

DOOR LOCKS

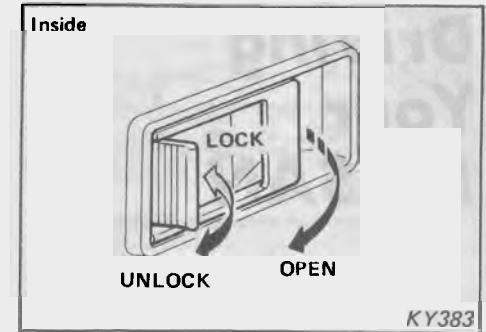
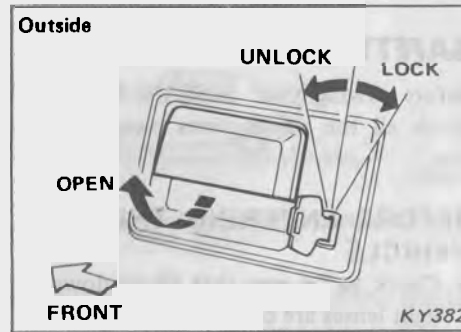

The key operates all the locks and the ignition switch on your NISSAN.

Record the key number so your NISSAN/DAISUN dealer will be able to replace a lost key.

It is also a good idea to keep your key number in your wallet together with your license.

If the driver's door is opened when the key is in the ignition switch, a chime will sound to remind you to remove the key. This will help prevent theft of your vehicle.

FROM OUTSIDE

The doors can be locked from the outside without a key. Move the inside lock knob to the "LOCK" position and then shut the door, pulling the outside door handle upward.

When locking the door without a key, be sure that the key has not been left inside the vehicle.

FROM INSIDE

All doors can be locked from inside the vehicle. When the door is locked, it cannot be opened by the inside door handle.

- **Always lock doors from the inside while driving. This provides greater safety in accidents, helps keep children from opening doors, and helps keep out intruders when stopped.**
- **Before opening the door, always look to be sure it is safe to do so.**

POWER DOOR LOCK

The passenger door can be locked (unlocked) by locking (unlocking) the door on the driver's side.

The passenger door can also be locked (unlocked) individually with the door lock knob.

SEATS

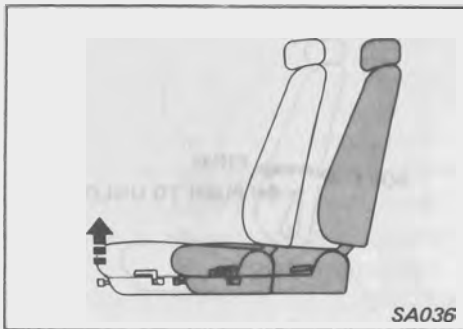

FRONT SEAT ADJUSTMENT

The fore-and-aft control lever located at the lower front of the seat releases the seat latch. To adjust the seat position, move the lever as shown and hold it while you slide the seat forward or backward to the desired position. Release the lever to lock the seat in position.

CAUTION:

- Do not adjust the driver's seat while driving. The seat may suddenly jerk forward or backward, which could result in loss of control.
- After adjustment, test to be sure seat is securely locked.

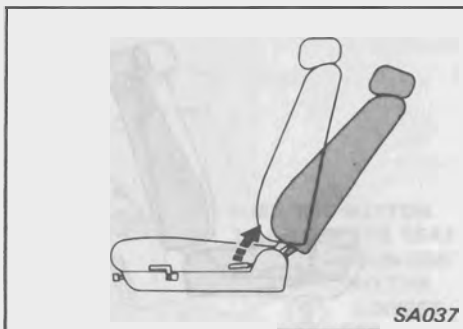

RECLINING SEATS

The reclining seat control levers are located at the outside of each front seat. To adjust the seatback, pull the lever upward, and lean back until the desired angle is obtained. To bring the seatback up again, pull the lever and it will move forward. When the desired angle is obtained, release the lever.

After adjustment, test to be sure seat is securely locked.

WARNING:

Never ride in a moving vehicle with the seatback in the reclining position. Seat belts are effective only when the wearer is in a comfortable upright position.

CAUTION:

Do not adjust the driver's seat while driving.

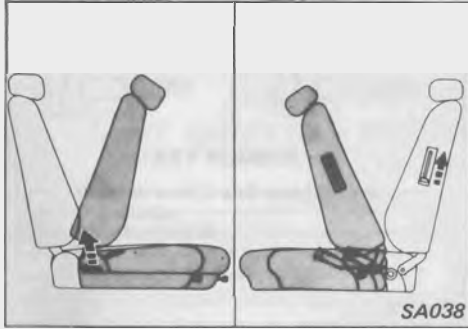

TILTING FRONT SEATS

2+2 model

To facilitate entry to the rear seat, the front passenger's seatback tilts as illustrated.

When the latch is released, the seatback will tilt forward and the seat will automatically slide forward.

Rear seat occupant can tilt the front passenger seat by moving the lever located on the side of the seatback.

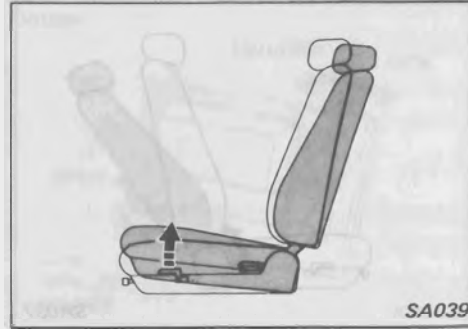

SEAT LIFTER

Adjust the angle of the seat cushion to any desired position by pulling up the lever.

CAUTION:

Do not adjust driver's seat while driving.

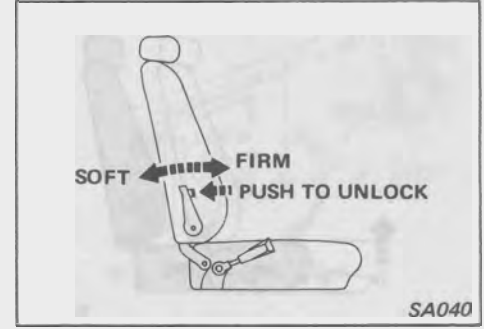

LUMBAR SUPPORT

To lessen fatigue from a long drive, adjust the firmness of the part of the driver's seat which supports the lumbar-vertebra area of the back.

The degree of firmness of the seat can be adjusted by operating the adjusting lever forward or rearward.

With the push button depressed, push the adjusting lever forward and the middle portion of the seatback will move slightly forward for increased lumbar support. To return the seatback to its original position, move your body forward slightly at the waist. Then, while depressing push button, lean back and the seatback will return to its original position.

CAUTION:

Do not adjust driver's seat while driving.



SIDE SUPPORT ①

Adjust the driver's seatback side support to the desired position by turning the dial on the side of the seatback cushion.

THIGH SUPPORT ②

Adjust the driver's seat cushion height to the desired position by moving the lever located at the lower front of the seat.

By repeatedly moving the lever up and down, the air bag in the seat cushion is filled with air, raising the seat cushion. Pushing the button on the lever causes air to escape from the air bag and the seat cushion to lower.

CAUTION:

Do not adjust the driver's seat while driving.

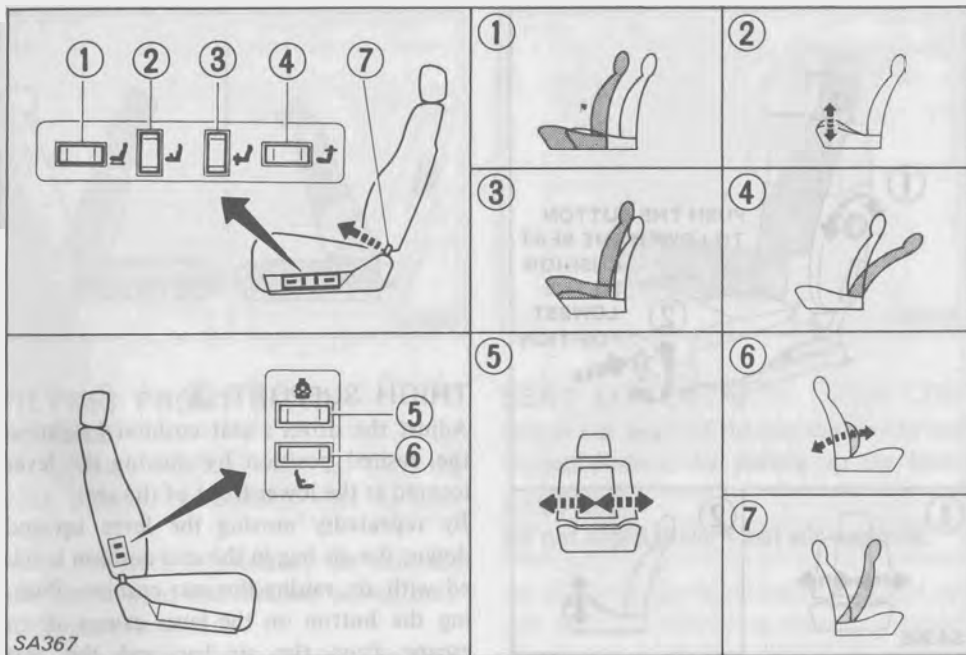

POWER SUPPORT ADJUSTMENT SEAT (Driver's seat only)

The fore-and-aft slide, reclining seatback, seat lifter, side support, lumbar support and thigh support can be adjusted by an electric system. Adjust them to the desired positions by pushing the switch on the seat's lower left side or seatback right side.

AMH00598

CAUTION:

- Do not adjust the driver's seat while driving.
- Do not leave the vehicle unattended with only children inside.
- When moving the seat slide to the full rear position, reclining the seat back or

lowering the lifter, be careful of the rear seat passengers.

- Switches ②, ⑤ and ⑥ operate an air pump. Avoid operating the air pump for an extended period of time. Although the system is designed to release air from a relief valve when each air mat is overfilled, the pump can be damaged if run excessively.
- If any of the motors stop while operating, wait a short period and then operate the circuit again. The circuits are designed to cut off electric current under overload conditions.
- Avoid using the power support adjustment seat continuously when the engine is stopped as it consumes a large amount of electric power. This is to prevent the battery from running down.



HEAD RESTRAINTS

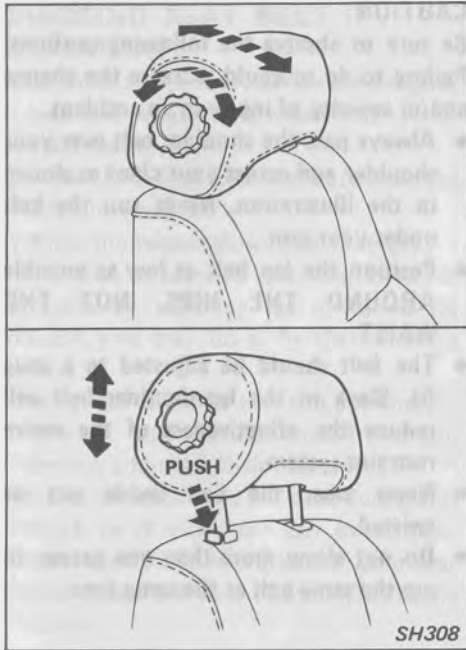

WARNING:
Head restraints may provide significant protection against whiplash injuries. Do not remove them.

Adjust the position which places the top of the head restraints closest to the top of your ears. To raise or lower, push the lock knob and slide the head restraint up or down. The fore-and-aft adjustment is made by moving the knob located on the side of the head restraint.

AMH00599

SEAT BELTS

Every person who drives or rides in this vehicle should wear a seat belt at all times.

Many scientific studies have shown that your chances of being injured in an accident and/or the severity of injury, may be greatly reduced if you are wearing your seat belt and it is properly adjusted. NISSAN strongly encourages you and all of your passengers to buckle up every time you drive. Infants, children and pregnant women should see the special precautions later in this section.

CAUTION:

Some states, provinces or territories may specify that seat belts be worn at all times when a vehicle is being operated.

Seat belts are provided for each seating position. Front seats are equipped with one-piece combination lap/shoulder belts and emergency locking retractors. Rear seats have lap belts with automatic locking retractors for the outboard positions (for models with rear seats). The system includes a reminder light and chime.



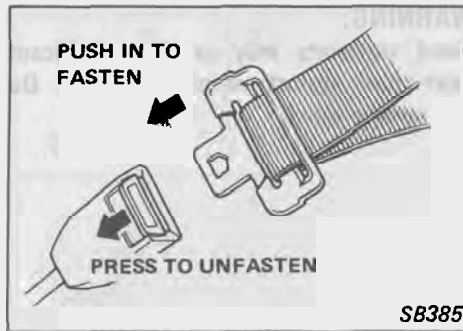

FRONT SEAT BELTS

1. Adjust the seat forward or back to the preferred driving position. Adjust the seat back to a comfortable **upright** position, the seat belts will be less effective if the seat is reclined. Sit upright and well back in the seat; your seat belts are more effective when you sit up and face forward.
2. Take hold of the tongue and slowly pull out the lap-shoulder belt. Remove any twists in the belt and insert the tongue into the buckle until you hear a snapping sound.
3. Position the lap portion of the belt across the lap as low on the hips as possible.

4. If the lap-shoulder belt is slack after you have buckled it, pull the shoulder belt portion toward the retractor to take up the slack.

The front seat belts have an emergency locking retractor which is designed to lock during a sudden stop or in certain kinds of accidents. Under normal circumstances the belt retractor permits the belt to move, allowing you some freedom of movement in the seat.

5. To unfasten the belt, press the button of the buckle. The seat belt will automatically retract.

CAUTION:

Be sure to observe the following cautions. Failure to do so could increase the chance and/or severity of injury in an accident.

- Always pass the shoulder belt over your shoulder and across your chest as shown in the illustration. Never run the belt under your arm.
- Position the lap belt as low as possible **AROUND THE HIPS, NOT THE WAIST.**
- The belt should be adjusted to a snug fit. **Slack in the lap-shoulder belt will reduce the effectiveness of the entire restraint system.**
- Never wear the belt inside out or twisted.
- Do not allow more than one person to use the same belt at the same time.

CHECKING SEAT BELT OPERATION

Your front seat belt retractors are designed to lock and restrict belt movement by two separate methods:

- 1) When the belt is pulled quickly from the retractor; and
 - 2) When the vehicle slows down rapidly.
- If you wish to increase your confidence in the belts by checking the operation for yourself, you may do so by the following method.

- Grasp the shoulder belt and pull sharply forward. The retractor should lock and prevent additional belt movement.
- If the retractor does not lock during this check or if you have any other questions about the operation of your seat belt, please see your NISSAN/DATSUN dealer.

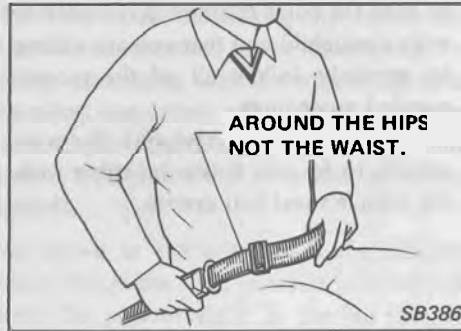

REAR SEAT BELTS

1. Grasp the tongue. Slowly and in one motion, pull the tongue until the belt fits around your lap. Insert the tongue into the buckle until you hear a snapping sound.

If pulling motion is interrupted, the retractor will lock and restrict further movement. If this happens, let the belt rewind into the retractor all the way and then the belt can be pulled out.

2. Position the belt on the hips as low as possible and adjust for a snug fit by pulling the belt firmly toward the retractor.

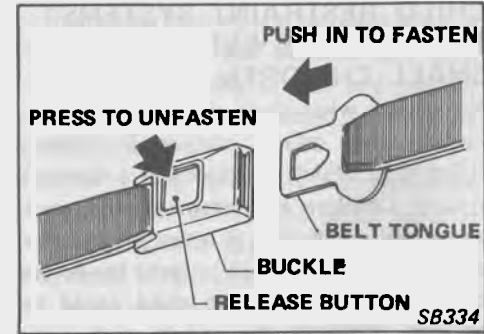

3. To unfasten the belt, press the button in the center of the buckle as illustrated. The seat belt will automatically retract.

CAUTION:

Position the lap belt as low as possible AROUND THE HIPS, NOT THE WAIST.

- Never wear the belt inside out or twisted.
- Do not allow more than one person to use the same belt at the same time.

CHILD RESTRAINT SYSTEMS FOR INFANTS AND SMALL CHILDREN

No matter what their size, it is very important that infants and small children riding in a vehicle be placed in a restraint system. **Children and infants should never be carried on the lap; it is not possible for even the strongest adult to resist the forces of an accident, and the child could be crushed between the adult and parts of the vehicle. Also, do not put the same seat belt around both your child and yourself. The rear seat is the safest place for a child. (Models with rear seat)**

Child restraint systems specially designed for infants and small children are offered by several manufacturers. Some systems may be used for both infants and small children.

When selecting any child restraint system, keep the following points in mind:

- 1) Choose only a system with a label certifying that it complies with Federal Motor Vehicle Safety Standard 213 or Canadian Motor Vehicle Safety Standard 213.
- 2) Place your child in the child restraint and try out the various adjustments to

AMH00602

be sure the child restraint is compatible with your child and that you are willing to regularly follow all of the recommended procedures.

- 3) Try out the child restraint in your vehicle to be sure it is compatible with the vehicle's seat belt system.

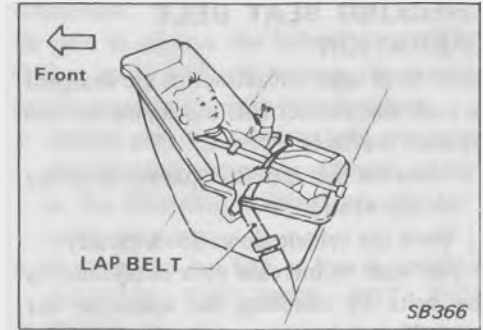

INSTALLATION ON REAR SEAT

Follow all of the child restraint manufacturer's instructions for installation and use. When purchasing a child restraint, be sure to select one which will fit in your vehicle as it may not be possible to properly install some types of child restraints on your vehicle.

Secure the child restraint with the lap belt as shown in the example illustration. When the lap belt is slack, adjust for a snug fit by pulling it toward the retractor. The automatic locking retractor will hold it snug.



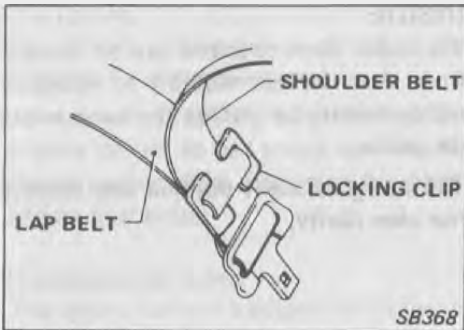
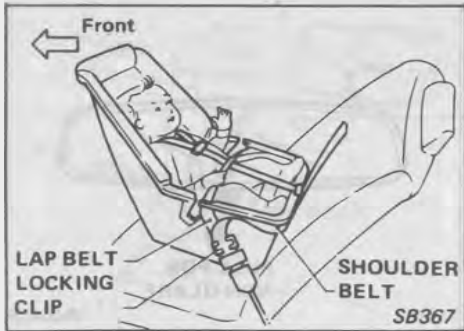

INSTALLATION ON FRONT SEAT

Follow all of the child restraint manufacturer's instructions for installation and use. A seat belt locking clip is required for installation of a child restraint system in the front seat of your vehicle.

AMH00603

For how to use the locking clip, follow the instructions attached to the locking clip. When purchasing a child restraint, be sure to select one which will fit in your vehicle as it may not be possible to properly install some types of child restraints on your vehicle.

As shown in the example in the illustrations, secure the child restraint with the lap belt. To prevent slack in the lap belt, it will be necessary to secure the lap/shoulder belt in place with a locking clip. Use a NISSAN genuine locking clip (part number 999JW-A3000, available from your Nissan/Datsun dealer), or one which is equivalent in dimensions and strength. After securing the locking clip, place the shoulder portion of the belt between the child restraint and the seat back.

When your child restraint system is not in use, keep the locking clip in the glove box to prevent it from being lost.

CAUTION:

- When your child restraint system is not in use, store it in the luggage room or keep it secured with a seat belt to prevent it from being thrown forward in case of a sudden stop or accident.

- Remember that a child restraint left in a closed vehicle can become very hot. Check the seating surface and buckles before placing your child back in the child restraint.
- Some states, provinces, or territories require that infants and small children be restrained in approved child restraint systems at all times while the vehicle is being operated.

CHILDREN

Children who are too large for child restraint systems, or who do not have an appropriate child seat available should be seated and restrained by the seat belts which are provided. Children seated in the front seat should wear both the lap and shoulder belts. If the shoulder belt contacts the neck or face due to the child's size, the child should sit in the rear seat and wear a lap belt. Infants who cannot sit up by themselves and who do not have a child restraint available may be placed in a well-padded bassinet, crosswise on the rear seat, with a seat belt around the bassinet.

Never let a child stand or kneel on any seat or allow a child in the cargo areas while the vehicle is moving. A child who must stand while riding should stand on the floor, behind the driver's seat. This will provide some protection in case of a sudden stop.

PREGNANT WOMEN

It is recommended that pregnant women use seat belts. Check with your doctor for specific recommendations. The lap belt should be worn snug and positioned as low as possible around the hips, not the waist.

INJURED PERSONS

It is recommended that injured persons use seat belts, depending on the injury. Check with your doctor for specific recommendations.

SEAT BELT MAINTENANCE

- To clean the belt webbings, apply a mild soap solution or any solution recommended for cleaning upholstery or carpets, brush it, wipe with a cloth and allow it to dry in the shade.
- Do not allow the belts to retract until they are completely dry.
- Do not use any other chemicals or try bleaching or re-dyeing the belt. These operations weaken the webbing.
- Periodically check the belt and the metal components such as buckles, tongues, retractors, flexible wires and anchors for deterioration or damage.
- If any component is found deteriorated or damaged, **or if the belt has been stressed because it was worn during an accident, the entire belt assembly should be replaced.**

REARVIEW MIRRORS

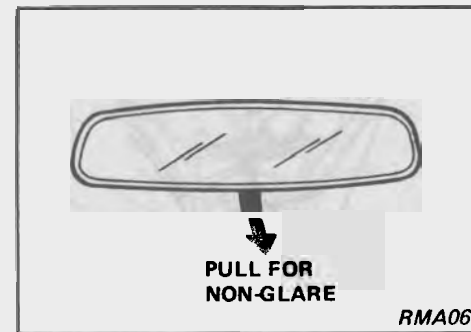

INSIDE

The inside rearview mirror can be changed from clear daylight visibility to non-glare night visibility by pulling the knob under the mirror.

The non-glare night position also reduces rear view clarity.

TRAILER TOWING

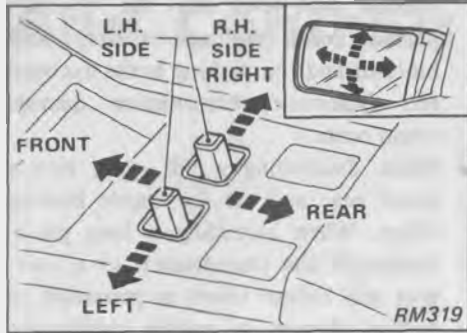

OUTSIDE

The outside mirror can be moved in any direction for better rear view.

To remove ice from the mirror surface, use a spray deicer; do not scrape ice from the mirror surface since damage to the mirror surface may occur.

Remote control mirror

This type of mirror is adjusted with the remote control switch located at the center console.

If ice forms on the mirror surface, remove it with a spray deicer before using the mirror.

Objects in the door mirror on the assist side are closer than they appear.

AMH00605

Your new NISSAN was designed to be used primarily to carry passengers and cargo. For your safety and that of your passengers, please read the following section carefully before towing a trailer. Remember that towing a trailer will place additional loads on your vehicle's engine, drive train, steering, braking and other systems.

MAXIMUM TRAILER LOAD

Never allow the total trailer load (trailer weight plus cargo weight) to exceed 1,000 lb (454 kg). Towing loads greater than this could have serious effects on your vehicle's handling and performance which could result in vehicle damage and/or personal injury.

MAXIMUM TONGUE LOAD

Never allow the tongue load to exceed 10% of the total trailer load. In addition, remember that tongue load should be considered part of the vehicle passenger and cargo load (Gross Axle Weight Rating). In no case should this load rating be exceeded; otherwise, vehicle handling, brak-

ing and performance may be adversely affected.

TRAILER HITCH

Choose a hitch design which is compatible with your vehicle and trailer and make sure the trailer hitch is securely attached to the vehicle, to help avoid personal injury due to sway caused by crosswinds, rough road surfaces or passing trucks. Axle-mounted hitches should not be used.

The hitch should not be attached to the bumper; in addition, it should be installed in a manner that will not affect the operation of the impact-absorbing bumper system.

No modifications should be made during hitch installation to the vehicle exhaust system, brake system, etc. If the hitch is removed, seal the bolt holes to prevent exhaust fumes, water or dust from entering the passenger compartment.

From time to time, check to make sure that all trailer hitch mounting bolts remain securely fastened.



TIRE PRESSURES

When towing a trailer, inflate the vehicle tires to the recommended cold tire pressure indicated on the tire placard (located on the inside of the center console-box lid.

Trailer tire condition, size, load rating and proper inflation pressure should be in accordance with the trailer and tire manufacturers' specifications.

SAFETY CHAIN

Always use a suitable chain between your vehicle and the trailer. The chain should be crossed and should be attached to the hitch, not to the vehicle bumper or axle. Be sure to leave enough slack in the chain to permit turning corners.

TRAILER LIGHTS

Trailer lights should comply with Federal and/or local regulations.

When wiring vehicle for towing connection, connect stop and tail light pickup into the vehicle electrical circuit at point between the sensor and stop light switch or light switch.

TRAILER BRAKES

If your trailer is equipped with a braking system, make sure it conforms to Federal and local regulations and that it is properly installed.

Under no circumstances should a trailer brake system be connected directly to the vehicle brake system.

TRAILER TOWING TIPS

In order to gain skill and an understanding of the vehicle's behavior, you should practice turning, stopping and backing up in an area which is free from traffic, because steering stability, operation and braking performance will be somewhat different than under normal circumstances.

- Avoid abrupt starts, acceleration or stops.
- Avoid sharp turns or lane changes.
- Always drive your vehicle at a moderate speed.
- Always block the wheels on both vehicle and trailer when parking. Parking on a slope is not recommended; however, if you must do so, and if your vehicle is equipped with automatic transmission, don't shift the trans-

mission shift lever into the "PARK" position until the wheels have been blocked and the parking brake has been set. Otherwise, transmission damage could occur.

- When descending a hill, shift into a lower gear and use the engine braking effect. When ascending a long grade, downshift the transmission to a lower gear and reduce speed as permitted to reduce chances of engine overloading and/or overheating.
- If the engine coolant rises to an extremely high temperature when the air conditioning system is "ON" turn the system "OFF".
- Trailer towing requires more fuel than under normal circumstances because of a considerable increase in traction power and resistance.
- Avoid towing a trailer during the "break-in" period.
- Have your vehicle serviced more often than at intervals specified in the recommended Maintenance Schedule.

When towing a trailer, change oil in the transaxle more frequently.

Refer to the Maintenance Schedule.

Instruments And Controls

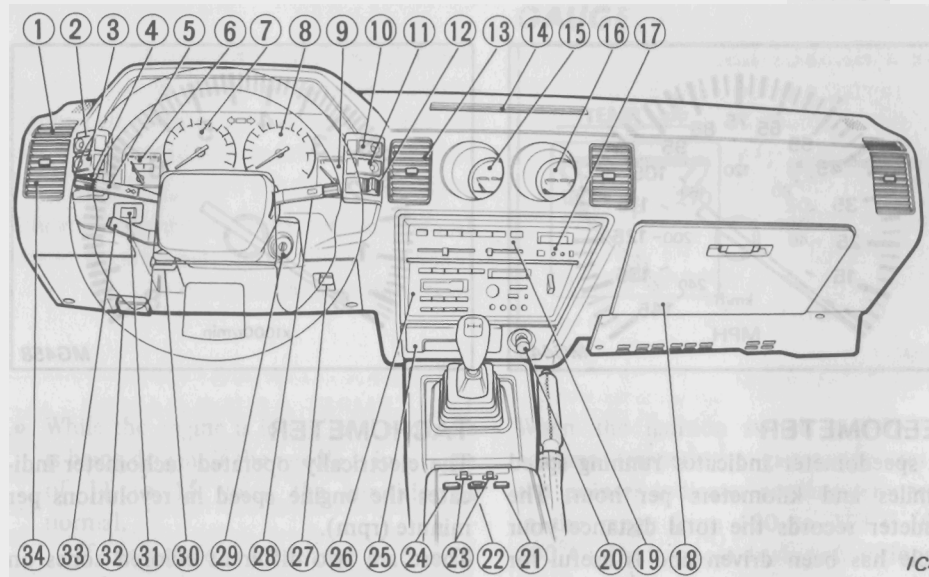

- ① Side defroster
- ② Retractable headlight switch
- ③ Hazard warning flasher switch
- ④ Cruise control main switch
illumination control rheostat
(Non-cruise control device model)
- ⑤ Light and turn signal switch
- ⑥ Fuel gauge
- ⑦ Speedometer
- ⑧ Tachometer
- ⑨ Coolant temperature gauge
- ⑩ Rear defogger switch
- ⑪ Auxiliary driving light switch
- ⑫ Rear window wiper and washer switch

AMH00607

- ⑬ Center ventilator
- ⑭ Upper ventilator
- ⑮ Oil pressure gauge (Non-turbo model)
Oil pressure and temperature gauge
(Turbo model)
- ⑯ Voltmeter (Non-turbo model)
Boost meter (Turbo model)
- ⑰ Clock
- ⑱ Glove box
- ⑲ Heater or air conditioner control
- ⑳ Cigarette lighter
- ㉑ Shock absorber adjusting switch
- ㉒ Headlight cleaner switch
- ㉓ Door mirror remote control switch
- ㉔ Door mirror defogger switch
- ㉕ Ash tray
- ㉖ Radio and cassette stereo player
- ㉗ Floor ventilation control lever
- ㉘ Windshield wiper and washer switch
- ㉙ Ignition switch
- ㉚ Tilt steering wheel adjust lever
- ㉛ Illumination control rheostat
(Cruise control device model)
- ㉜ Hood release handle
- ㉝ Cruise control lever
- ㉞ Side ventilator

SPEEDOMETER



TACHOMETER

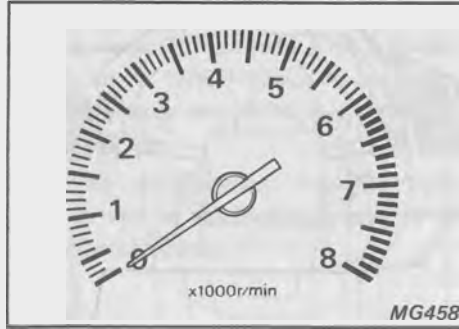

SPEEDOMETER

The speedometer indicates running speed in miles and kilometers per hour. The odometer records the total distance your vehicle has been driven and is useful for keeping a record of maintenance intervals. Two trip odometers are provided which individually record the distance your vehicle has traveled after they are reset. The last digit in orange indicates 1/10 of a mile (km for Canada). Reset the trip odometer to zero by pressing the reset knob.

TACHOMETER

The electrically operated tachometer indicates the engine speed in revolutions per minute (rpm). There are two different colored zones on its face. Operating the engine with the needle in the red zone can lead to serious engine damage.

VOLTMETER

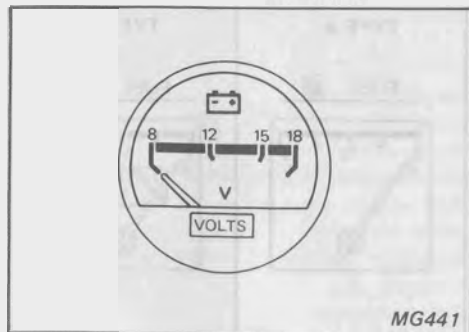

The voltmeter monitors the condition of the charging system and the state of the battery, as outlined below:

- Before starting the engine, check the position of the needle when the ignition switch is in the "ON" position.
If the needle is not in a range of 11 to 12 volts Check the condition of the battery.
- During starter operation
If the needle is in a range of 6.0 to 10 volts Normal condition.

After starter operation, the needle may sometimes stay within a range of 6 to 8 volts, even though nothing is wrong with the battery or charging system.

The needle will fall back as the battery is discharged.

AMH00609

COOLANT TEMPERATURE GAUGE

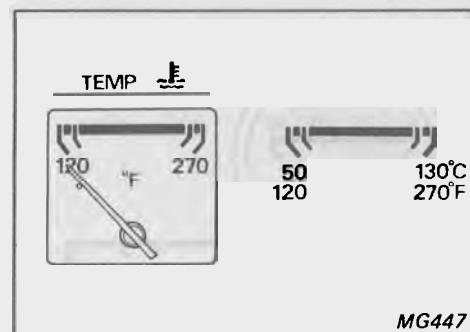

- While the engine is idling or the vehicle is being driven, if the needle is in a range of 11 to 15 volts, the condition is normal.

If the needle is in a range of 6 to 11 volts or 16 to 18 volts
. The problem may be

- Loose fan belt
- Condition of battery or charging system
- Electrical overload

Have the condition checked by your NISSAN/DATSUN dealer or other competent service facility.

When the ignition switch is "ON", the coolant temperature gauge operates and the pointer indicates coolant temperature in the range from 120 to 270°F (50 to 130°C). Under most driving conditions, the needle will remain at approximately the halfway point.

Stop-and-go driving, driving at high speeds in warm weather, or driving up a steep grade may cause the needle to move toward the hot side.

CAUTION:

Do not continue to drive your vehicle when the needle has swung fully to the hot side. This will cause overheating and damage the engine. If your vehicle overheats, refer to "In Case of Emergency".

OIL PRESSURE AND TEMPERATURE GAUGE

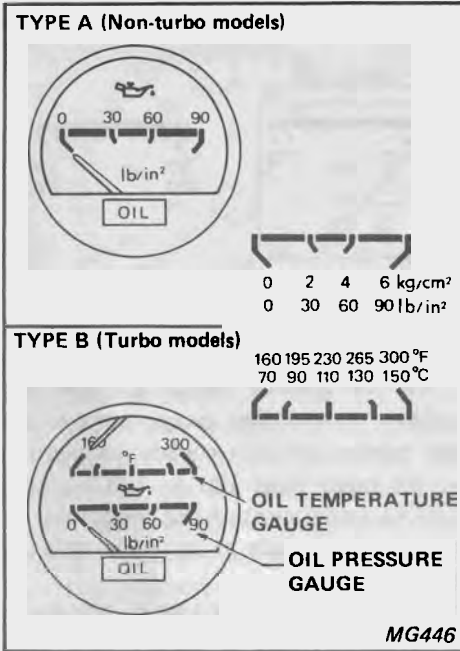

OIL PRESSURE GAUGE

When the ignition switch is "ON", the oil pressure gauge indicates the oil pressure with the engine running.

During ordinary driving, the needle will remain 35 to 60 psi (2.5 to 4 kg/cm², 250 to

400 kPa) at 2,000 rpm with the engine at normal operating temperature.

If the needle moves below 30 psi (2 kg/cm², 200 kPa) at 2,000 rpm, stop the engine and check the engine oil level.

In cold weather, the engine oil pressure will increase slightly until the engine has reached its normal operating temperature.

OIL TEMPERATURE GAUGE

When the ignition switch is "ON", the engine oil temperature gauge operates and the pointer indicates oil temperature in the range from 160 to 300°F (70 to 150°C). During ordinary driving, the pointer will indicate 170 to 270°F (75 to 130°C).

CAUTION:

Do not continue to drive your vehicle when the pointer has swung all the way to 280°F (140°C) as this will damage the engine. Have the condition checked by your NISSAN/DATSUN dealer or other competent service facility.

FUEL GAUGE

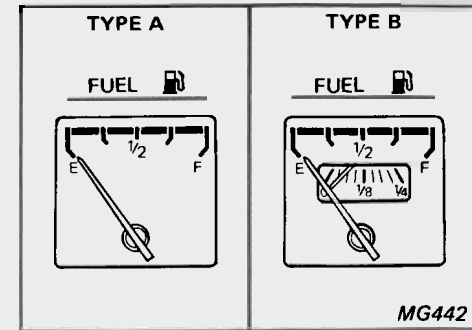

When the ignition switch is "ON", the fuel gauge registers the APPROXIMATE fuel level in the tank. The position of the needle will vary slightly when accelerating, braking, or when the vehicle is going up or down hill. Check your fuel supply when the vehicle is on level ground, either parked or moving at a constant speed.

- When the ignition switch is turned "OFF", the fuel gauge needle will remain at almost the same position that it held before the switch was turned off. However, the indication may vary slightly when parking the vehicle for extended periods of time.
- It is advisable to refill the fuel tank before the gauge registers Empty.

BOOST METER

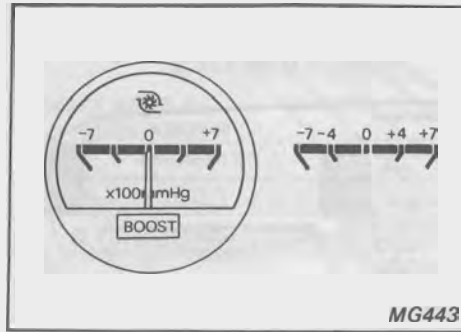

- When filling up with fuel, it will take a little time for the needle to stabilize.
- When the fuel tank is filled up, the needle on the fuel gauge may move beyond the "F" position or stay in that position for a while.

Dual type

A sub-gauge is provided on the dual type fuel gauge as well as the main gauge which indicates the fuel level between the Full and the Empty mark.

The sub-gauge registers the fuel level after the fuel has dropped to or below the one-quarter (1/4) mark on the main gauge dial.

There is no malfunction indicated if the needle should become visible when the fuel level is above the 1/4 mark.

When the engine is running, the boost meter indicates the pressure in the intake manifold. The boost meter indicates a negative pressure when the engine is idling or the vehicle is moving at extremely low speeds. A positive indication on the meter shows that the turbocharger is operating.

CAUTION:

When the pressure exceeds the maximum positive or negative value shown on the meter, stop the vehicle as engine components could be damaged. Have the condition checked at your nearest NISSAN/DATSUN dealer or other competent service facility.

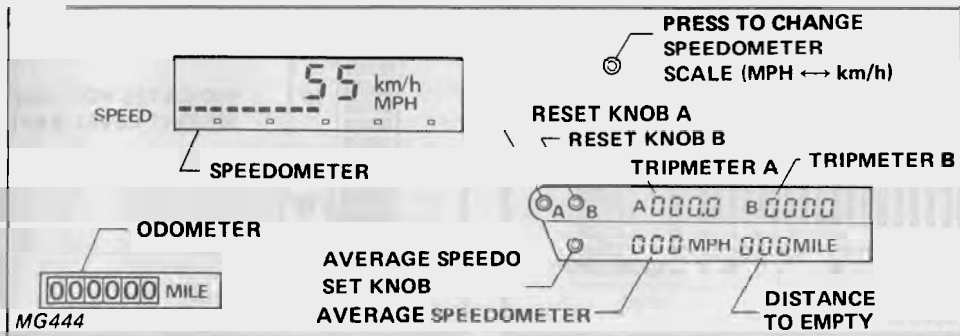

AVERAGE SPEEDOMETER

This speedometer indicates the average vehicle speed after pressing the set knob in “MPH (U.S.A.)” or “km/h (Canada).” Even if the ignition is turned off, the computation of the average speed continues as long as the battery cables are not disconnected.

Because signals from the clock are fed to the speedometer for computation, the average speed display will be reset if the clock is adjusted.

SPEEDOMETER

The speedometer indicates the vehicle speed in digital and graphic displays in “MPH (U.S.A.)” or “km/h (Canada).”

Push the MPH, km/h select knob once to change the digital display from “MPH” to “km/h”, or vice versa.

ODOMETER

The odometer records the total mileage your vehicle has been driven and is useful for keeping a record of the maintenance interval.

TRIPMETER

Two tripmeters are individually provided to record the distance your vehicle has traveled after they are reset. On tripmeter A, the last digit indicates 1/10 of a mile (km for Canada). Reset the tripmeter to zero by pressing the reset knob.

DISTANCE TO EMPTY

From the average fuel consumption in the last 1-mile (1-km for Canada) driven and the remaining quantity of fuel, the meter computes the driveable distance before the fuel runs out and indicates it in “Miles (U.S.A.)” or “kms (Canada).”

The driveable distance will not be displayed when the remaining fuel has decreased less than about 1-7/8 US gal (1-1/2 Imp gal, 7 liters).

TACHOMETER

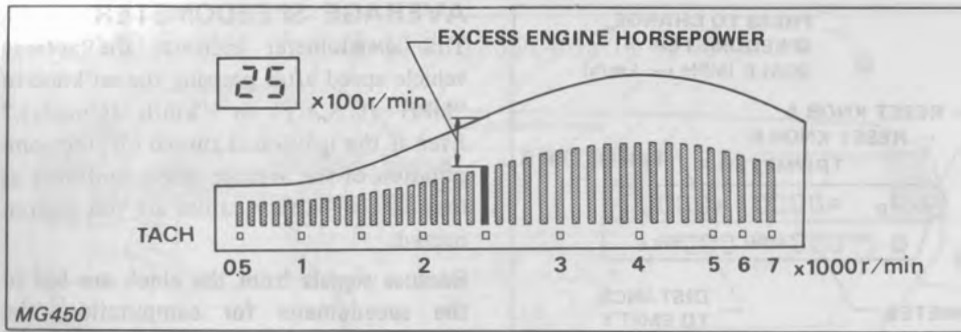

The tachometer indicates the engine speed (rpm) in a digital and graphic-bar display. The digital indicates 1/100 of the actual rpm. For example, an indication of "25" means 2,500 rpm. In the graphic-bar display, the brightest vertical bar indicates the engine speed. The length of the brightest vertical bar indicates the boost pressure in the intake manifold, and the difference between the maximum curve and the indicated length of the brightest vertical bar shows the excess engine horsepower.

AMH00614

VOLTMETER

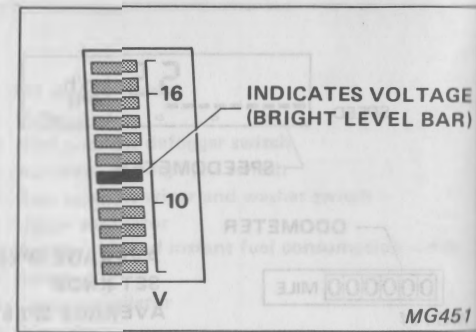

The level brighter than other segments indicates the voltage.

The voltmeter monitors the condition of the charging system and the state of the battery, as outlined below:

- Before starting the engine, check the position of the indicator when the ignition switch is in the "ON" position.
If it is not in a range of 11 to 14 volts Check the condition of the battery.

- During starter operation
The normal range is 6.0 to 10 volts.

After starter operation, the meter may sometimes indicate within a range of 6 to 8 volts even though nothing is wrong with the battery or charging system.

OIL PRESSURE GAUGE

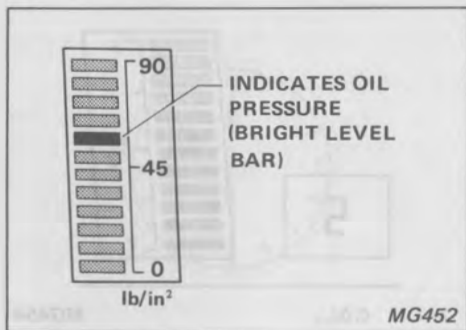

- While the engine is idling or the vehicle is being driven, the normal range is 11 to 15 volts.

If it indicates a range of 6 to 11 volts or 16 to 18 volts The problem may be

- Loose fan belt
- Condition of battery and alternator.
- Electrical overload

Have the condition checked by your NISSAN/DATSUN dealer or other competent service facility.

AMH00615

The engine oil pressure during engine operation is indicated by the level brighter than other segments in the oil pressure gauge.

The pressure is normal if the gauge remains within the range of from 2nd to 12th lights corresponding to the engine rpm.

CAUTION:

- If the gauge remains low even when the engine speed is increased, the lubricating system should be inspected. Stop the engine, and check the engine oil level. If the oil level is normal, the system is malfunctioning. Have the vehicle checked immediately by your NISSAN/DATSUN dealer or other competent service facility.



- In cold weather, the oil pressure may increase temporarily after starting the engine.
- If the oil pressure drops abnormally or fluctuates a lot during engine operation, stop the engine and check for oil quantity.

COOLANT TEMPERATURE GAUGE

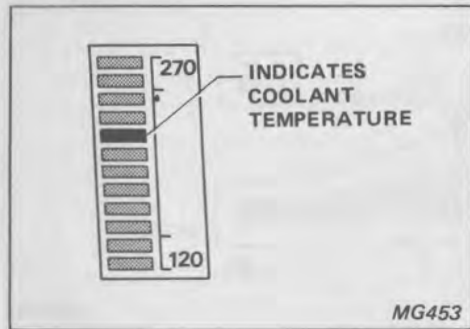

FUEL GAUGE

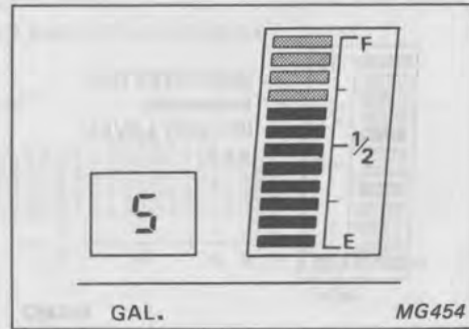

The coolant temperature is indicated by the level brighter than other segments in the coolant temperature gauge. Under most driving conditions, the indicator will remain at approximately the halfway point. Stop-and-go driving, driving at high speeds in warm weather, or driving up a steep grade may cause the indicator to move toward the upper side.

CAUTION:

Do not continue to drive your vehicle when the temperature rises up to the top segment. This will cause overheating and damage the engine. If your vehicle overheats, refer to "In Case of Emergency".

The APPROXIMATE fuel level in the tank is indicated by the graphic bar brighter than other segments in the fuel gauge.

The position of the indicator will vary when turning, accelerating, braking, or when the vehicle is going up or down a hill. Check your fuel supply when the vehicle is level, whether stationary or moving.

The digital gauge begins to indicate the remaining amount of fuel in gallons (U.S.A.) or liters (Canada) when it is about 5 US gal (4-1/8 Imp gal) (U.S.A.) or 19 liters (Canada). The gauge will indicate until the remaining amount of fuel is 2 US gal (1-5/8 Imp gal) (U.S.A.) or 5 liters (Canada). If the amount falls below that, a letter "E" blinks.

It is advisable to refill the fuel tank before the gauge registers Empty. When filling up with fuel, it will take a little time for the indicator to stabilize.

ACCELERATION GAUGE AND INSTANT FUEL CONSUMPTION METER

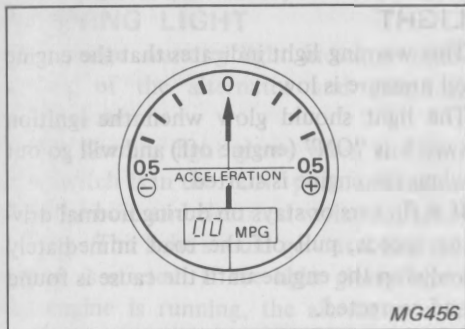

Acceleration gauge

The acceleration gauge indicates the acceleration and deceleration of the vehicle in the gravitational acceleration unit G. The figure appearing on the plus side is the acceleration and that on the minus side, the deceleration. Zero is displayed during constant-speed straight driving.

Instant fuel consumption meter

The mileage meter indicates occasional fuel consumption digitally in MPG (U.S.A.) or km/l (Canada). Even if driving conditions change, the indication will remain unchanged for about 10 seconds. When the accelerator pedal is released during driving to actuate engine braking, fuel injection may be cut. In this case, the maximum fuel consumption "99" will be displayed.

AMH00617

COMPASS

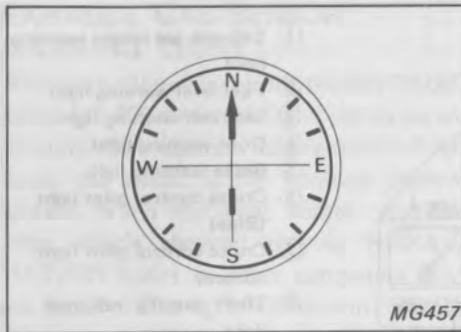

The letters, N, E, S, and W, on the gauge correspond respectively to the North, East, South, and West of a compass, and the arrow points in the direction which the vehicle is heading. Since the arrow indicates the direction with reference to magnetic north, its indication is somewhat different from the actual bearing on a map.

The compass may sometimes fail to point to the correct direction in weak magnetic environments such as when driving through a tunnel, near a building or under an iron bridge. Do not put any magnetic material (such as magnetic mount CB antenna base, etc.) on or close to the roof.

WARNING/INDICATOR LIGHT AND CHIME

Needle type

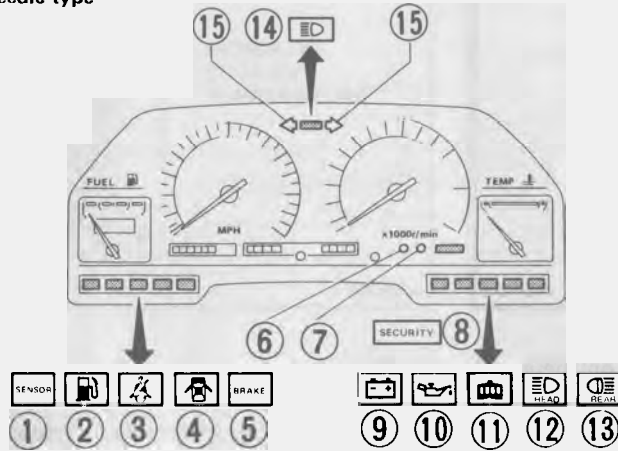

Digital type

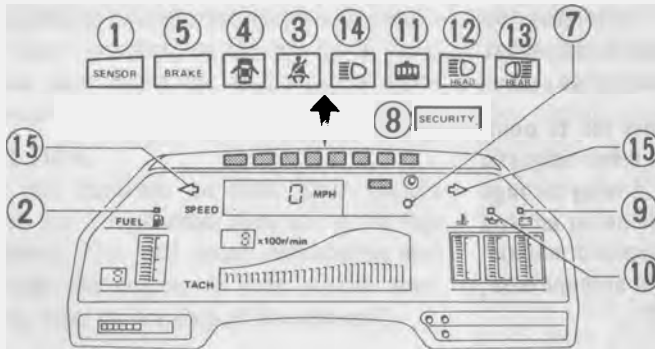

- ① Exhaust gas sensor warning light
- ② Fuel level warning light
- ③ Seat belt warning light
- ④ Door warning light
- ⑤ Brake warning light
- ⑥ Cruise control pilot light (Blue)
- ⑦ Cruise control pilot light (Green)
- ⑧ Theft warning indicator light
- ⑨ Charge warning light
- ⑩ Oil pressure warning light
- ⑪ Coolant level warning light
- ⑫ Headlight monitoring light
- ⑬ Tail light monitoring light
- ⑭ High beam indicator light
- ⑮ Turn signal/Hazard indicator lights

OIL PRESSURE WARNING LIGHT

This warning light indicates that the engine oil pressure is low.

The light should glow when the ignition switch is "ON" (engine off) and will go out when the engine is started.

If it flickers or stays on during normal driving speeds, pull off the road immediately and stop the engine until the cause is found and corrected.

When the engine is idling, after a long high-speed trip, momentary flickering of the warning light is of no concern if the light goes out upon accelerating the engine.

CAUTION:

Continued running of the engine when the oil pressure warning light is on may damage the engine.

CHARGE (Alternator) WARNING LIGHT

The charge warning light indicates functioning of the alternator and electrical wiring system.

If this warning light glows when the ignition switch is in the "ON" position (engine off), the bulb and electrical wiring are satisfactory. The light should go out when the engine is started. If the light glows when the engine is running, the alternator and electrical system should be checked as soon as possible.

If the alternator and electrical system are functioning normally, but the electrical load is too heavy, the charge warning light may glow slightly. When this occurs, there is no need to check the alternator and electrical system.

FUEL LEVEL WARNING LIGHT

The fuel warning light comes on when the fuel in the fuel tank drops below 2-1/8 US gal (1-3/4 Imp gal, 8 liters) with the ignition switch "ON". When the fuel warning light comes on, refuel at the nearest gas station.

CAUTION:

Do not try to start your vehicle with no fuel in the system.

EXHAUST GAS SENSOR WARNING LIGHT

When the odometer reading reaches 30,000 miles (48,000 km), this light comes on indicating the required maintenance of exhaust gas sensor in the emission control system. When the light comes on, have your vehicle checked at your NISSAN/DATSUN dealer or other competent service facility. This light will remain on until the system has been properly serviced. Before 30,000 miles (48,000 km), this light comes on only when the ignition switch is turned to "ON" position with the engine stopped. If the light does not come on, under this condition, check the electrical system for a burned-out bulb or an open circuit.

This system does not operate, after maintenance has been performed at 30,000 miles (48,000 km).

BRAKE WARNING LIGHT

This warning light functions for both the parking brake and the foot brake systems. The warning light glows when the ignition switch is turned to the "ON" position and the engine is not running. If the light does

not glow, check the electrical system for a burned-out bulb or an open circuit.

Parking brake system

The warning light will continue to glow when the parking brake is applied with the engine running.

Brake fluid level indicator system

With the engine running and the parking brake not applied, the warning light glows if the fluid level is lower than the prescribed level.

If the warning light glows while you are driving, brake fluid level should be checked immediately. All brake components should also be checked for leakage of brake fluid. Add brake fluid or make other repair as necessary.

CAUTION:

If these checks cannot be made immediately, pull off the road and stop carefully. Remember that your stopping distance may be longer and the pedal may go down farther than normal and be more difficult to operate. Test the brakes by carefully starting and stopping on the shoulder of the road. If you judge it to be safe, drive carefully to the nearest service station for repairs. Otherwise have your vehicle towed. Driving it could be dangerous.

SEAT BELT WARNING LIGHT AND CHIME

The driver's seat is equipped with a seat belt warning light and chime system.

The seat belt warning light "FASTEN BELTS" comes on for about six seconds whenever the ignition switch is placed in the "ON" position.

The seat belt warning chime will sound for about six seconds when the ignition switch is placed in the "ON" position unless the driver's seat belt is securely fastened.

LIGHTS "ON" WARNING CHIME/VOICE

A chime or voice (refer to the "Voice Warning") will sound if the driver side door is opened when the ignition key is removed from the switch with the light switch turned on. The chime or voice stops when the light switch is turned off.

KEY WARNING CHIME

The warning chime warns the driver that the ignition key is in its slot. The chime will sound if the driver's door is opened when the ignition key is in the "ACC", "OFF" or "LOCK" position.

DOOR WARNING LIGHT

The door warning light comes on when one or more doors and tailgate are not closed securely while the engine is running. The light glows when the ignition switch is turned ON and the engine is not running. If the light does not glow, check the electrical system for a burned-out bulb or an open circuit.

COOLANT LEVEL WARNING LIGHT

This light comes on when the coolant level in the reservoir tank drops below the "MIN" level mark.

HEADLIGHT MONITORING LIGHT

This light comes on with the headlight switch in the  position, if the headlight bulb is burned out on at least one side.

TAIL LIGHT MONITORING LIGHT

This light comes on with the light switch in the "ON" position if the tail light bulb is burned out on at least one side.

HIGH BEAM INDICATOR LIGHT

The headlights have two beams to meet varying night driving conditions.

The high beams give you better long range visibility on dark roads in suburban areas. With the headlights on, the beam indicator glows whenever the high beams are being used, and goes off when the low beams are selected.

TURN SIGNAL/HAZARD INDICATOR LIGHTS

The green indicator light on the instrument panel flashes simultaneously with the exterior turn signal lights.

THEFT WARNING INDICATOR LIGHT

Refer to the section titled "THEFT WARNING SYSTEM".

CRUISE CONTROL PILOT LIGHT

Refer to the section titled "CRUISE CONTROL" in the "Starting And Operating" instructions.

VOICE WARNING

Each voice warning is sounded to warn the driver of the following conditions. The voice warning continues until the condition is corrected. Only the voice warning "FUEL LEVEL IS LOW" is repeated two or three times and then stops.

If more than one item requires warning simultaneously, warning is sounded in the order of priority, as follows:

- When the ignition switch is in the "ON" position:

- ① RIGHT DOOR IS OPEN.
- ② LEFT DOOR IS OPEN.
- ③ PARKING BRAKE IS ON.
- ④ FUEL LEVEL IS LOW.

- When the ignition switch is in the "OFF" position:
LIGHTS ARE ON.

WARNING OPERATION

"RIGHT DOOR IS OPEN"

will sound when the right door is open and the vehicle is moving over 5 MPH (10 km/h).

"LEFT DOOR IS OPEN"

will sound when the left door is open and the vehicle is moving over 5 MPH (10 km/h).

"PARKING BRAKE IS ON"

will sound when the vehicle is moving over 5 MPH (10 km/h) if the parking brake is applied before the vehicle is in motion yet not released. However, if the parking brake is applied while the vehicle is in motion, the voice warning will not sound.

"FUEL LEVEL IS LOW"

will sound when the ignition switch is in the "ON" position and the fuel in the fuel tank drops below 2-5/8 US gal (2-1/4 Imp gal, 10ℓ). The warning will be repeated 2 or 3 times and then stop.

"LIGHTS ARE ON"

will sound when the light switch is "ON", the driver's door is opened and the ignition switch is "OFF".

DISC BRAKE WEAR INDICATOR

The front and rear disc brake pads have audible wear indicators. When the brake pad wears to such an extent that it needs to be replaced, the audible wear indicator will make a high-pitched sound similar to that of a wire brush striking a cymbal (or a maraca being shaken). This sound will be heard continuously or discontinuously when the car is in motion, no matter when foot brakes are applied. If this warning sound is heard, have the brakes checked as soon as possible to prevent the pad from being worn out completely and the rotor from being damaged subsequently. This sound may not be heard when driving in noisy areas, when the car radio is operating or when windows are closed. Check the disc brake pads for wear in accordance with the Maintenance Schedule even if the wear indicator does not make a sound.



THEFT WARNING SYSTEM



The theft warning system has been designed to protect your belongings in the vehicle and the vehicle itself from being stolen when all doors, hood and rear hatch are locked.

If an attempt is made to forcibly open the door, hood, or rear hatch without using the key, the system not only causes the headlights and horn to activate, but also makes it impossible for the starter to operate.

CAUTION:

This warning system will not function unless the vehicle is set in the armed condition. Accordingly, when you leave the vehicle, be sure to take the key with you, lock all doors, and confirm that the indicator light comes on and the vehicle is armed.

WARNING OPERATION

Conditions that cause an alarm

This warning system is activated by the following:

- Opening the door or rear hatch without using the key.
Even if the door or rear hatch is opened by releasing the door inside lock knob or by operating the opener lever, the warning will activate.
- Opening the hood.
- Pushing in or pulling out the key cylinder of the door or rear hatch.

Alarm description

The warning system will give the following alarm.

- The headlights flicker and the horn sounds intermittently. In addition, the starter is fixed so that the engine will not start.
- The alarm automatically comes to an end in 2 to 4 minutes. However, if tampered with again, the system will give the alarm once more.

If this occurs, the alarm will continue to sound and the starter will not work until the door or rear hatch is unlocked with the key.

TO SET THE VEHICLE IN THE ARMED CONDITION

1. Remove the key from the ignition switch, close and lock all doors, hood and rear hatch.
 - The door can be locked either with or without the key.
 - It does not matter in what order the doors, hood and rear hatch are locked.
2. The indicator light will come on for about 30 seconds when the door, hood or rear hatch is last locked. The warning system is armed, after the light goes off.
 - If during this 30 second time period, the door is unlocked or the ignition key is turned to "ACC" or "ON", the system will not arm. After that, if the key is removed and the doors, hood, and rear hatch are locked, the system will again be armed.

CAUTION:

a) If the key is turned slowly when locking the door, the system may not arm. Furthermore, if the key is turned to the unlock side when removing it, the system will likely be reset.

If the indicator light fails to come on, unlock the door once and lock it again in order to turn on the indicator light and thus arm the warning system.

b) When the driver is in the vehicle, the ignition switch is "OFF", and the driver's door is locked, and a person outside the vehicle closes the hood or rear hatch or locks the doors, the vehicle will become armed. In this case, the driver should turn the key once to "ACC" or "ON", and then open the door in order to prevent the warning system from activating.

c) When the doors, hood and rear hatch are locked, and the driver gets out before the passengers do and locks the driver's door, the vehicle will become armed. In this condition, if a passenger opens the door by releasing the inside lock knob, the warning will activate. THEREFORE, THE DRIVER'S DOOR SHOULD BE LOCKED AFTER ALL PASSENGERS GET OUT OF THE VEHICLE.

AMH00623

d) Even with a door window left open, the vehicle will become armed. At that time, always unlock the door with the key, because the system will activate if unlocked by pulling up the inside lock knob.

e) After the alarm is activated, it cannot be stopped by turning on the ignition switch. To stop the alarm, unlock the door or rear hatch with the key.

TO TURN OFF THE WARNING SYSTEM WHEN ARMED

To turn off the warning system when armed, unlock the door or rear hatch with the key or turn the ignition switch to "ACC" or "ON".

TO STOP ALARMS

When the system has started to alarm due to an error, it can be stopped by unlocking the door or rear hatch with the key.

- The alarm will not stop even if the ignition switch is turned to "ACC" or "ON".

SECURITY INDICATOR LIGHT OPERATION

An indicator light, provided on the instrument pad, gives different indications, letting the driver know the condition of the warning system.

NOTE:

- If the ignition switch is "OFF" and the door, hood, or rear hatch is open, the indicator light will flicker to remind the driver to arm the system.

If the door is closed and left unlocked, the light will go off and the vehicle will be left disarmed.

- The indicator light will come on for about 30 seconds when the last door (hood or rear hatch) is locked, after which the light will go off indicating the warning system is armed.

If any abnormalities are found such as the indicator light does not go on and off properly or the warning system cannot be set, have the system checked by your NISSAN/DATSUN dealer or other competent service facility.



WINDSHIELD WIPER AND WASHER SWITCH

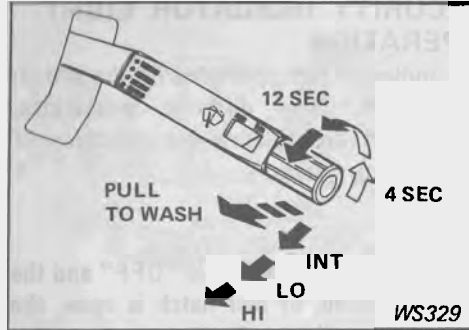

The switch controls the speed of the windshield wiper and also controls the windshield washer.

To operate the washer, pull the lever toward you and hold it until there is enough fluid on the windshield to wash off dirt.

Intermittent time control knob

The intermittent time control knob is attached to the switch lever. When this knob is turned with the switch lever in the intermittent (first) position, wiper blade operation can be adjusted to an intermittent duration of from 4 to 12 seconds.

- **Check washer fluid level regularly.**
- **Do not operate the washer continuously for more than thirty seconds.**
- **In cold weather, defrost the windshield glass before operating the washer.**
- **Do not substitute radiator anti-freeze for windshield washer solutions.**
- **Do not wipe the glass with a dry cloth. It may scratch the glass.**
- **Do not operate the washer if the reservoir is dry.**

REAR WINDOW WIPER AND WASHER SWITCH

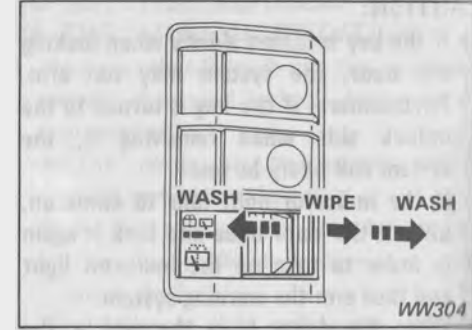

The rear window wiper switch has one speed. When the switch is pushed to the right, the wiper blade is activated. To operate the washer, push the knob to the left when the wiper is stopped and to the right when it is operating and hold it until there is enough fluid on the glass to wash off the dirt. For general precautions, refer to descriptions under the heading "Windshield Wiper and Washer Switch".

HEADLIGHT CLEANER SWITCH

PUSH TO WASH



HC303

Open the headlights by turning on the retractable headlight switch or the headlight switch.

Washer fluid is sprayed on the headlight lens by pushing the rear end of the switch button.

This switch does not operate when the headlights are closed.

For general precautions, refer to the “Windshield Wiper and Washer Switch”.

REAR WINDOW DEFOGGER SWITCH

PUSH TO TURN ON



DS311

An electric defogger is built into the rear window.

To heat the rear window glass, push the switch to the “ON” position.

A rear window defogger monitoring light installed in the switch will glow to indicate the system is on.

The switch operates only when the ignition switch is in the “ON” position.

The rear window defogger will automatically turn off approximately 15 minutes after the switch is turned “ON”.

If you need it further, push the switch again.

CAUTION:

When you clean the vehicle, do not clean the inner side of the window with abrasive-type cleaners, and do not use any type of scraper to remove foreign deposits from the inner glass surface as this may damage the electrical conductors.

DOOR MIRROR DEFOGGER SWITCH

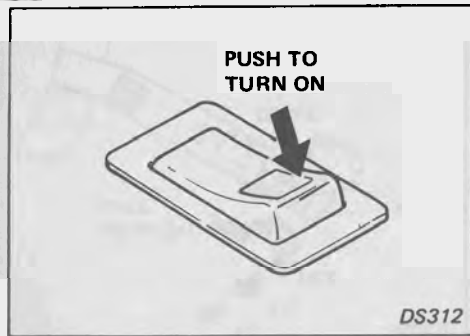

An electric defogger is built into the door mirrors. To heat the door mirror glass, push the rear end of the switch. A defogger monitoring light on the switch will glow to indicate the system is on.

The switch operates only when the ignition switch is in the "ON" position.

When the defogger is not in use, turn off the switch.

RETRACTABLE HEADLIGHT SWITCH

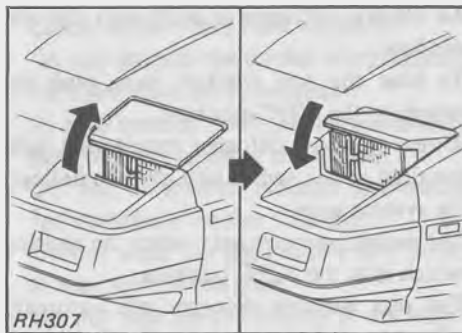
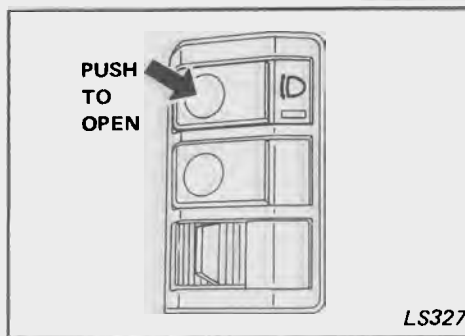

When the switch is set to "ON", the retractable headlights will open. This switch does not turn on the headlights.

CAUTION:

Before operating the switch, make sure that no one is near the headlights.

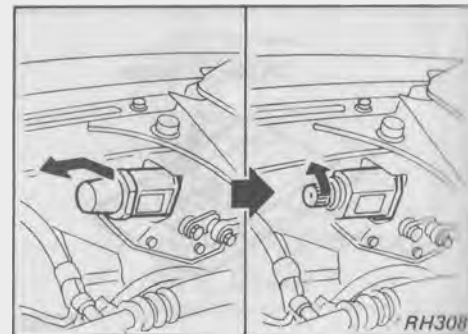

Emergency procedures when headlights do not open/close

1. Turn off the light combination switch and the retractable headlight switch, then disconnect the negative terminal of the battery or the fusible link.
2. Remove the motor shaft cap beside each headlight.
3. To open or close the headlights, turn the motor shaft counterclockwise by hand.
4. Reinstall the motor shaft cap.

Be sure to have the headlights checked and repaired by your NISSAN/DATSUN dealer or other competent service facility.

LIGHT SWITCH

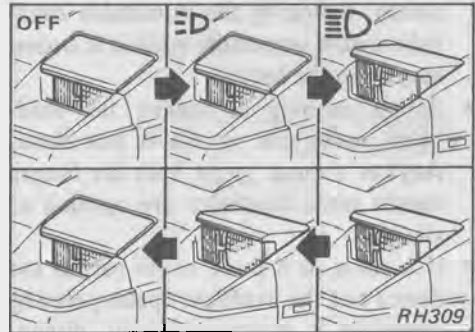
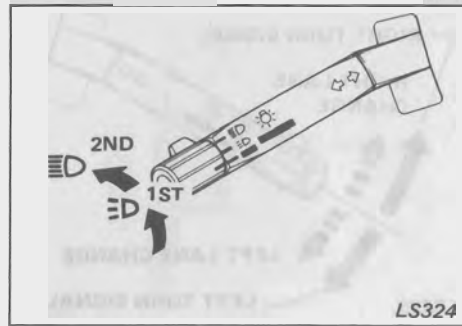

CAUTIONS:

- Remove the negative terminal of the battery or the fusible link.
- If work is started without disconnecting the negative terminal of the battery or the fusible link, the headlights and motor shaft may suddenly begin moving and catch your fingers.

When the light switch knob is turned on, the following lights will come on.

1ST POSITION

Parking (or clearance), tail, license plate, side marker, key illumination, automatic transmission selector lever indicator, heater (air conditioner) control panel, rear window defroster illumination and instrument panel lights.

2ND POSITION

Headlights and all the above lights. (The headlight high/low beams are controlled by the light/turn select lever.)

Retractable headlights

The retractable headlights will open and come on when the light combination switch is set in the 2ND position, and will close when the switch is set in the "OFF" position.

CAUTION:

- When driving in cold weather or on a snowcovered road and there is a possibility the headlight mechanism will become frozen, drive or park your vehicle with the headlights opened. (Operate the retractable headlight switch, not the light combination switch.) If the mechanism is frozen and will not operate, be sure to carefully melt or break the ice before operating the

TURN SIGNAL SWITCH AND HEADLIGHT BEAM SELECTOR

switch. Operating the retractable headlight switch repeatedly while it is frozen may drain the battery.

- Before opening or closing the headlights, make sure no one is near them. Anyone around might have his fingers caught while headlights are opening or closing.
- If a stone or a piece of ice gets in the device and the headlight opening-closing operation is stopped halfway, disconnect the battery or the fusible link and remove the obstacle; then operate the switch again.

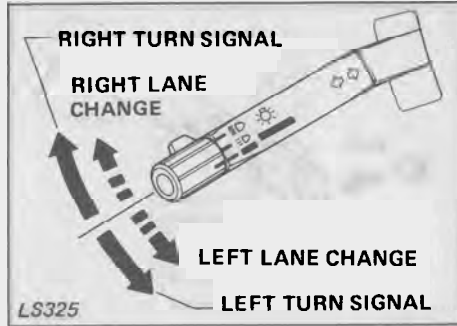

TURN SIGNAL

With the lever at either upward or downward position, lights flash on the front and rear of the vehicle, indicating the direction you are about to turn.

A corresponding turn signal indicator light on the instrument panel tells you which set of signals —right or left— is operating.

The turn signals cancel automatically when you have completed a turn (like driving around a corner) and steering wheel has returned to the straight ahead position.

LANE CHANGE SIGNAL

To indicate a lane change, move the lever up or down to a point where it begins flashing. The lever will return to the neutral position when released.

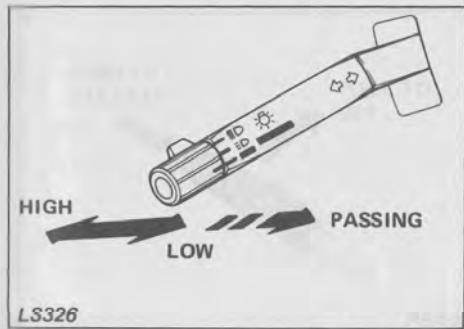

HEADLIGHT BEAM SELECTOR

The light/turn select lever also controls headlight high-low beam when the light switch is turned to the 2nd position.

If the high beam is on, the high beam indicator light on the instrument panel glows.

PASSING SIGNAL

The high beam lights will come on when the turn signal lever is moved fully toward the driver, irrespective of the light switch position. Release the lever to turn lights off.

If the turn signal lever is pulled when the headlights are opened, the high beam lights will come on. If the signal lever is pulled when the headlights are closed, the headlights will open and come on. Release the lever and the headlights will go out and close. If the lever is released before the headlights have completely opened, the headlights will continue to the full-open position and then will go out and close.

AUXILIARY DRIVING LIGHT SWITCH

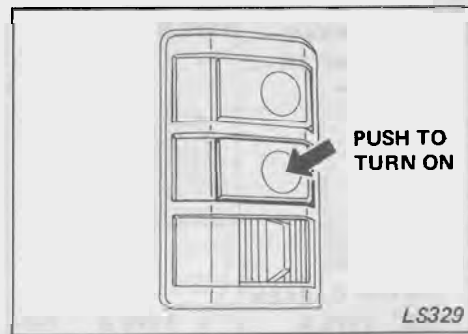

The light comes on when the switch is pressed and goes out when pressed again. The switch operates only when the headlights come on.

ILLUMINATION CONTROL RHEOSTAT

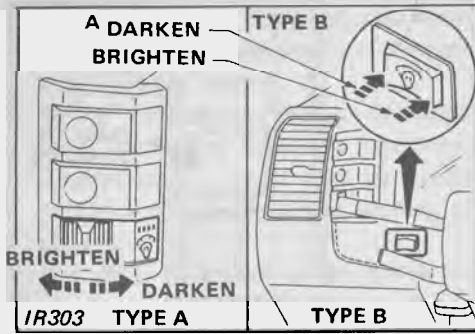

HAZARD WARNING FLASHER SWITCH



The illumination control rheostat is located on the instrument panel. The brightness of all instrument illumination lights can be adjusted by pushing the control switch.

TYPE A

When the switch is pushed to the left, the illumination lights brighten. Pushing to the right will reduce their brightness.

TYPE B

Pushing the right side of the switch will brighten the illumination lights. They will darken when pressed to the left side.

All directional signals flash when the flasher switch is on to warn other drivers and pedestrians that your vehicle is disabled or parked under emergency conditions.

The flasher can be actuated with the ignition switch either off or on.

- **When stalled or stopped on the roadway under emergency conditions, move the vehicle well off the road.**
- **Do not use the switch while moving on the highway unless unusual circumstances force you to drive so slowly that your vehicle might become a hazard to other traffic.**
- **Some state laws may prohibit the use of the hazard warning flasher switch under any circumstances.**

- **Turn signals do not work when the switch is operating.**

PARKING BRAKE LEVER

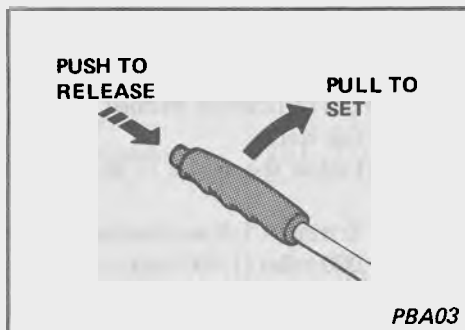

To set the parking brake, pull the lever upwards. It is a good practice to depress the foot brake pedal at the same time.

To release, pull upward. Then depress the push button and push down all the way.

If the ignition switch is "ON", the brake warning light will continue to glow as long as the parking brake is engaged.

For proper parking procedures see "Parking" under the heading "Starting and Operating".

CAUTION:

Make sure that the parking brake is completely released before driving.

If you drive a vehicle with the parking brake partially engaged, the rear brake shoes may be damaged.

AMH00631

HORN

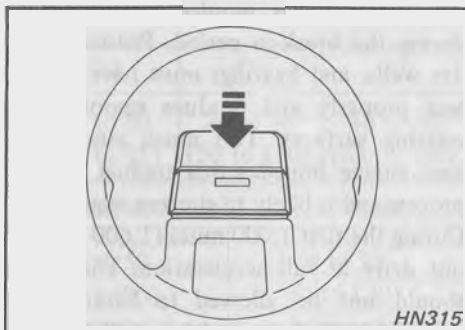

The horn sounds when the horn button (or pad) is pressed firmly.

Use the horn to warn pedestrians or other drivers of the possibility of danger. Excessive use of the horn should be avoided.

Starting And Operating

BREAK-IN SCHEDULE

All new vehicles require careful driving during the break-in period. Pistons, cylinder walls, and bearings must have time to seat properly and produce smooth, long wearing surfaces. Too much strain on a new engine impedes this gradual break-in process and is likely to shorten engine life. During the first 1,000 miles (1,600 km), do not drive at full acceleration. The engine should not be allowed to labor before downshifting when climbing a hill. Variable speeds are best during the break-in period. Always drive so that the engine runs fast enough to prevent strain.

Fuel economy will vary in the first few thousand miles (kilometers) of operation due to engine break-in. And it is also dependent upon driving habits and proper maintenance.

Therefore to conserve fuel and assist the break-in:

- Do not drive at high speeds before the engine has sufficiently warmed up.
- Avoid fast starts.
- Do not allow the engine to labor in any gear.
- Avoid driving at full acceleration for the first 1,000 miles (1,600 km).
- Do not race the engine.
- Avoid extended idling periods.
- Except in an emergency, avoid heavy braking or rough usage of the brakes.



CATALYTIC CONVERTER

Break-in speed limit MPH (km/h)

	1st	2nd	3rd	4th	5th
Manual transmission	0 to 22 (0 to 35)	15 to 37 (25 to 60)	22 to 60 (35 to 95)	30 to 80 (50 to 130)	40 to 80 (65 to 130)
Automatic transmission	"1" Low		"2" Second		"D" Drive
	0 to 30 (0 to 50)		22 to 50 (35 to 80)		0 to 75 (0 to 120)

The figures listed in the chart refer to potential speed ranges for each gear. The speed at which you drive, however, should conform to all federal, state, province and territory laws, and to the condition which will permit safe operation.

A catalytic converter for emission control is installed in the exhaust system. Inside this converter, exhaust gases are burned at high temperature to help reduce pollutants.

Certain engine malfunctions, particularly involving the electrical, fuel injection or ignition systems, will result in large amount of unburned fuel, causing the converter to reach elevated temperatures. Discontinue operation of the vehicle if the engine misfires, or if noticeable loss of performance or other unusual operating conditions are detected.

Instead, have the vehicle inspected by an authorized NISSAN/DATSUN dealer or other competent service facility.

CAUTION:

- Use **UNLEADED GASOLINE ONLY** of the type recommended in "Oil and fuel recommendation" under the heading "Do-It-Yourself". Leaded gasoline will seriously damage catalytic converter.
- Keep an eye on your fuel gauge; running out of gas could possibly cause damage to the catalytic converter.
- Refrain from racing the engine.



TURBOCHARGER SYSTEM

- d) Do not stop or park the vehicle over inflammable materials, such as dry grass, waste paper, or rags that may come into contact with the exhaust system.
- e) When parking, ensure that people or inflammable materials are kept away from the exhaust pipe.

The turbocharger system uses engine oil for lubrication and cooling of its rotating components. The turbocharger turbine turns at speeds in excess of 100,000 rpm at full throttle, its temperature can reach 1,600°F (870°C). It is essential to maintain a clean supply of oil flowing through the turbocharger system. Therefore, a sudden interruption of oil supply may cause a malfunction in the turbocharger.

To ensure prolonged life and performance of the turbocharger, it is essential to comply with the following maintenance procedure:

1. Change your engine oil every 5,000 miles (8,000 km) or 6 months, whichever comes first. More frequent maintenance may be required under severe driving conditions. Use only the recommended oil.
2. If the engine had been operating at high rpm for an extended period of time, let it idle for a few minutes prior to shut-down.
3. Do not accelerate your engine to high rpm immediately after start.

STARTING THE ENGINE

EXHAUST GAS WARNING (Carbon Monoxide)

Never inhale exhaust gases; they contain carbon monoxide, a colorless, odorless extremely dangerous gas which can cause unconsciousness or death. If you should suspect that exhaust fumes are getting into the passenger compartment, have the vehicle examined and the leakage corrected immediately. If you must drive under these conditions, drive only with ALL windows FULLY OPEN and ventilator fan operating.

1. It is not advisable to sit for any length of time in a parked vehicle with the engine running.
2. Do not run the engine in closed spaces such as a garage for any longer than is absolutely necessary.
3. When a vehicle has been stopped in an open area with its engine running for any significant length of time, turn the ventilator on to force outside air into the vehicle.
4. If the rear hatch is not closed while driving, exhaust gases could be drawn into the vehicle. Avoid driving for any length of time with the rear hatch open.

If it is necessary to drive in this manner, open windows and operate ventilation fan.

5. Always assure that the front ventilator inlet grille is free from snow, leaves or any other kind of obstruction so that vehicle's ventilation system will be able to function properly at all times.
6. The exhaust system and body should be inspected by a qualified mechanic whenever:
 - a. The vehicle is raised for service.
 - b. You suspect that exhaust fumes are getting into the passenger compartment.
 - c. You notice a change in the sound of the exhaust system.
 - d. You have had an accident involving damage to the exhaust system, underbody, or rear of the vehicle.



IGNITION SWITCH

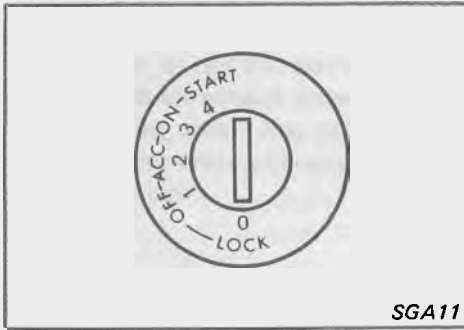

The switch includes the anti-theft steering lock device and also controls the ignition system and most of the electrical equipment:

“LOCK” Normal parking position

The ignition key can be inserted and removed at the “LOCK” position only. The steering can be locked by turning the key to the “LOCK” position, removing it, and rotating the steering wheel until the locking plunger clicks into position.

To unlock the steering, insert the key and turn it to the “OFF” position. For easier key operation when unlocking, rotate the steering wheel slightly to relieve pressure on the steering lock.

AMH00636

WARNING:

Never remove the ignition key while driving. If the key is removed, the steering wheel will lock, and it will become impossible to control the vehicle.

“OFF”

The position permits turning the engine off without locking the steering wheel.

“ACC” (Accessories)

This position allows you to use all the electrical accessories controlled by the switch.

“ON” Normal operating position

This position turns on the ignition system and electrical circuits.

“START”

This position starts the engine. After the engine has started, release the key. It will automatically return to the “ON” position.

BEFORE STARTING THE ENGINE

The seat belt warning light flashes on for about six seconds when the ignition switch is placed in the “ON” position.

The warning chime will sound for about six seconds when placing the ignition switch in the “ON” position if you do not fasten the driver’s seat belt securely.

1. Make sure the parking brake is applied.
2. Place the gearshift lever into “Neutral” (in “N” or “P” position for the automatic transmission).

With manual transmission model, do not attempt to start the engine in any gear position except “Neutral”. If any gear is engaged without depressing the clutch, the vehicle will lurch forward or backward.

3. With a manual transmission, it is a good practice to depress the clutch pedal to reduce drag from the transmission gears, while starting.



TIPS ON STARTING

1. To start the engine, turn on the ignition switch without depressing the accelerator pedal.
 - If the engine is very hard to start in extremely cold or hot weather, use the accelerator pedal to help start the engine.
 - In the summer, when restarting the engine within 30 minutes after it has been stopped, crank the engine keeping the pedal fully depressed.
2. As soon as the engine starts running under its own power, release the ignition key and accelerator pedal.
3. If the engine stops or falters in starting, wait 3 or 4 seconds before restarting. This will prevent possible damage to the starting motor or engine.

If it becomes necessary to start the engine with a booster battery and jumper cables, the instructions and cautions contained in the "In Case of Emergency" should be carefully followed.

Warm-up

Always allow the engine to idle for at least 30 seconds after starting and drive at moderate speed for a short distance, especially in cold weather.

DRIVING WITH MANUAL TRANSMISSION

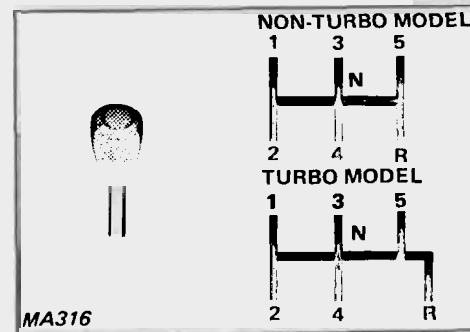

To shift gears, fully depress the clutch pedal and then operate the gearshift lever. When shifting the lever from a Forward gear to Reverse, or from Reverse to a Forward gear, be sure to first bring your vehicle to a complete stop.

On the non-turbo model, you cannot shift directly from 5th gear into Reverse, but must first shift into Neutral, then into Reverse.

Apply the parking brake when at a standstill. When starting to move the vehicle, release the parking brake and drive away.

CORRECT SHIFT-UP SPEEDS

The table below indicates the recommended speeds for shifting up to a higher gear.

Unit: MPH (km/h)

Shifting	1 → 2	2 → 3	3 → 4	4 → 5
Shift-up speed	15 (25)	25 (40)	40 (65)	45 (75)

SPEED RANGES IN EACH GEAR

The following table indicates the speed ranges in which the vehicle may be driven or downshifted in each gear without over-revving. Never run the engine in a higher gear than is required for the speed you are traveling as this will place a great strain on the components and may damage the en-

gine or drive train. Always downshift when slowing to negotiate a sharp turn, when proceeding up a steep hill, or when slowing down appreciably for any reason. When braking, disengage the clutch when your speed has fallen to 10 to 15 MPH (15 to 25 km/h) and continue braking to a stop.

Unit: MPH (km/h)

Gear position	1st	2nd	3rd	4th	5th
Speed range	0 to 30 (0 to 50)	15 to 55 (25 to 90)	22 to 80 (35 to 130)	Over 30 (Over 50)	Over 40 (Over 65)

- When you are shifting from one gear to another, be certain to press the clutch pedal all the way to the floor to avoid clashing or chipping the gears.
 - Shift into reverse gear only after the vehicle has come to a complete stop.
 - Do not use the clutch pedal as a foot rest between gear changes as this may result in clutch damage.
 - Never hold the vehicle in position on a steep hill by slipping the clutch.
 - To maintain safe speeds on steep down grades and to help save the brakes, shift to a lower gear before you start down.
 - When quick acceleration is required, shift to a lower gear and accelerate until the vehicle reaches the maximum speed in each gear. Do not exceed the speed limit of any gear.
- Use caution when accelerating or when shifting into a lower gear on slippery surfaces. Sudden acceleration or downshifting could cause the wheels to skid and result in loss of control.
- The figures listed in the chart refer to potential speed ranges for each gear. The speed at which you drive, however, should conform to all federal, state, province and territory laws, and to the condition which will permit safe operation.

DRIVING WITH AUTOMATIC TRANSMISSION

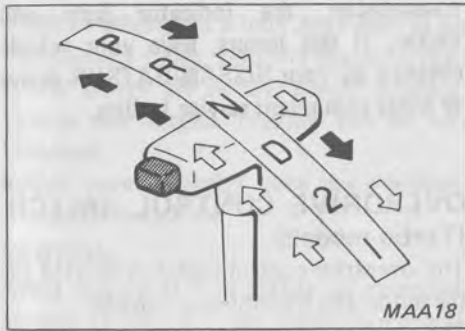

HOW TO OPERATE SELECTOR LEVER

Push the button located on the end of the selector lever when engaging “R” and “P” and when shifting from “D” to “2”, as indicated by the arrow “➡”.

The lever can be shifted freely into any positions indicated by the arrow “↔”.

- Start the engine in the “P” or “N” position. It will not start in any other selector position. If it should, have your vehicle checked by your NISSAN/DATSUN dealer or other competent service facility.
- Shift into “N” position and apply the parking brake when at a standstill. Before moving the vehicle, apply the foot

brake and shift into the driving position. This prevents the vehicle from creeping. Release the parking brake and drive away slowly.

- Keep the engine at idling speed while shifting from “N” to any driving position.
- When stopped on an upgrade, do not hold vehicle using engine. Use your brakes.

“P” PARKING:

After parking, apply the parking brake and set the selector lever in the “P” position. This position locks the transmission and rear wheels. Do not shift into “P” while the vehicle is moving.

“R” REVERSE:

Shift into the “R” position only after the vehicle has completely stopped. Then gently depress the accelerator pedal to back up.

“N” NEUTRAL:

In the “N” position neither forward nor reverse gear is engaged.

“D” NORMAL DRIVE POSITION:

This position is used for most city and highway driving. Press the accelerator pedal slowly to increase vehicle speed. The 4-forward gears are upshifted automatically from low to second, to third and to overdrive. When speed decreases, downshifting is also automatic.

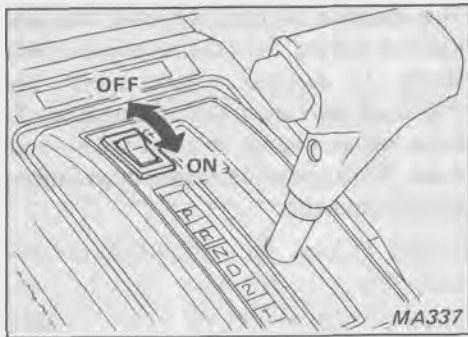

PATTERN CHANGE SWITCH (Non-turbo models)

There are two types of driving patterns available with your automatic transmission: Normal pattern and power pattern. To select either pattern, use the Pattern Change Switch located at the front of the automatic transmission console.

Normal Pattern

Available when the switch is in the “OFF” position. This is the most effective mode for routine, stop-and-go driving or driving on the freeway. Normal pattern driving also allows for maximum fuel efficiency.

In some instances, when the accelerator pedal is depressed for increased power during normal pattern driving, the trans-

mission may move into the power pattern mode even though the switch is in the “OFF” position, this is a normal operating condition. The indicator light on the switch will come on when this occurs.

Power Pattern

Available by moving the switch to the “ON” position. The indicator light will come on when this selection is made. If the switch is turned on while driving in overdrive, the transmission automatically shifts down into 3rd gear.

The power pattern driving mode is most effective for:

- Quick acceleration for passing or for entrance onto freeways, and turnpikes.
- Uphill driving for better control of engine acceleration.
- Downhill driving such as long slopes, and mountain roads, to obtain better engine braking (deceleration).

The indicator light will also come on when the ignition switch is turned to the “ON” position with the engine stopped. If it does not come on, check the electrical system for a burned out bulb or an open circuit.

CAUTION:

If any abnormality occurs in the automatic

transmission, the indicator light will flicker. If this occurs, have your vehicle checked by your NISSAN/DATSUN dealer or other competent service facility.

OVERDRIVE CONTROL SWITCH (Turbo models)

The overdrive control switch is located on the automatic transmission console.

The overdrive indicator light is located on the switch.

- To operate the overdrive gear, push the switch to the “ON” position. With the selector lever in the “D” position, the transmission is upshifted to overdrive as the vehicle increases speed. The light glows when the transmission is upshifted to overdrive.
- When the vehicle is accelerated by operating the “ACCEL” set switch of the cruise control, the transmission is shifted down to third gear even when the overdrive control switch is turned on.
- When the switch is turned off and the select lever is in the “D” position, the transmission is upshifted automatically from 1st to 2nd and to 3rd, but will not be upshifted to overdrive.

- When driving on a long slope such as on mountain roads, turn the overdrive control switch off so that proper acceleration and engine braking can be obtained.
- For normal driving, turn the overdrive control switch on.

CAUTION:

Avoid driving at high speeds for extended periods of time with the overdrive control switch turned off.

"2" SECOND GEAR:

Use the "2" position when starting on slippery roads or ascending hills and for effective engine braking on downhill grades.

Do not downshift into the "2" position at speeds over 62 MPH (100 km/h) for the non-turbocharger model and 60 MPH (95 km/h) for the turbocharger model. Do not exceed 62 MPH (100 km/h) for the non-turbocharger model and 60 MPH (95 km/h) for the turbocharger model in the "2" position.

"1" LOW GEAR:

The "1" low gear is helpful for driving up very steep hills and for braking the vehicle on downhill grades. When downshifting into the "1" position, move the selector lever from "D" to "2" and then to "1".

Even if the selector lever is downshifted into "1", the vehicle remains in second gear until the vehicle speed drops below 30 MPH (50 km/h). Do not shift into the "1" position at speeds over 62 MPH (100 km/h) for the non-turbocharger model and 60 MPH (95 km/h) for the turbocharger model. Do not exceed 37 MPH (60 km/h) in the "1" position.

ACCELERATOR DOWNSHIFT —In "D" POSITION—

You can get extra power and acceleration for rapid passing or hill climbing by completely depressing the accelerator pedal to downshift the gears. The accelerator downshift makes the transmission downshift into second gear when driving below 60 MPH (95 km/h) for the non-turbocharger model and 55 MPH (90 km/h) for the turbocharger model and into low gear when driving below 30 MPH (50 km/h).

PARKING

BEFORE LEAVING YOUR VEHICLE

1. Set the parking brake.
2. **Manual transmission models:**
Place the gearshift lever in the "Reverse" position.

When parking on an uphill grade, place the gearshift lever in the "1st" position.

Automatic transmission models:

Place the gearshift lever in the "P" position.

CAUTION:

Safe parking procedures require that both the parking brake be set and the transmission placed in the "P" (park) position. Make sure the shift lever has been pushed as far forward as it can go and cannot be moved without depressing the button at the end of the lever.

3. Turn the ignition key to the "LOCK" position. Never leave an unattended vehicle with its engine running.
4. Remove the ignition key.
5. Lock all doors.
6. Never leave children unattended in vehicle.

TIPS ON DRIVING

DRIVING UPHILL

When starting on a steep grade, it is sometimes difficult to operate both the brake and clutch. Use the parking brake to hold the vehicle. Do not slip the clutch. When ready to start, slowly release the parking brake while depressing accelerator pedal and releasing the clutch.

DRIVING DOWNHILL

The engine braking action is effective for controlling the vehicle while descending hills. The gearshift lever should be placed in the lower speed position prior to descending. With the automatic transmission vehicle, the “2” or “1” position should be selected.

WET BRAKES

When the vehicle is washed or driven under extremely wet or muddy conditions, the brake linings sometimes get wet. In a safe manner and as traffic conditions permit, gently apply the brakes several times as the vehicle is moving slowly to dry the linings. Do not drive the vehicle at high speeds until the brakes are functioning correctly.

SPARK PLUGS

The factory-installed spark plugs on your vehicle are designed to meet normal driving conditions. If your vehicle is operated under either of the following conditions, it is recommended that optional spark plugs of the proper heat range be installed.

1. When the vehicle is used primarily for short distance travel, so that the engine does not run long enough to reach its

normal operating temperature, use hot-type spark plugs.

2. When the vehicle is frequently operated with throttle wide open for long periods of time, use cold-type spark plugs.

For spark plug types, please consult your NISSAN/DATSUN dealer or other competent service facility.

Recommended spark plugs

Engine	Hot type	Standard type	Cold type
Non-turbocharger model	BCPR5ES-11*	BCPR6ES-11*	BCPR7ES-11*
Turbocharger model	BCPR5E-11*	BCPR6E-11*	BCPR7E-11*

Always use the spark plug, or its equivalent, indicated in the above chart.
Resistor built-in type spark plug

*: NGK make

IN COLD WEATHER

STARTING OFF ON SLIPPERY ROADS

When rain or snow makes the roads slippery, use caution in accelerating and engaging the clutch. If the clutch is engaged too abruptly and with too much acceleration, the wheels may spin and the vehicle will not move forward. To stop the spin, apply the brake and then back up a little. Repeatedly rolling backward and forward will get you away from the slippery patch. In an emergency situation, the vehicle carpet can be used as skidmatting.

DRIVING ON SLIPPERY ROADS

Hard driving, braking, or cornering on wet or slippery roads should be avoided. When braking under these conditions, shift to a lower gear and use the braking effect of the engine to assist the foot brakes.

When driving on icy roads, always proceed slowly and cautiously, turn the steering wheel gently, and use the brakes only very lightly. Moreover, always change gears smoothly, and never drive with the clutch pedal depressed.

If you should go into a skid, do not apply the brakes. Release the accelerator slowly and turn into the direction of the skid. As the vehicle stops skidding, straighten out the wheels and accelerate lightly.

FREEING A FROZEN DOOR LOCK

To prevent a door lock from freezing, apply de-icer or glycerin to it through the key hole. Should the lock become frozen, heat the lock key before use.

REPLACING LUBRICANT

When the temperature drops below 10°F (-12°C), it is recommended that the engine lubricating oil be replaced with one of a lower viscosity. Refer to “Recommended SAE Viscosity Number” under the heading “Do-It-Yourself”.

ANTI-FREEZE

In the winter when it is anticipated that the temperature will drop below 32°F (0°C), check anti-freeze (ethylene glycol base) to assure proper winter protection. For details, refer to “Engine Cooling System” under the heading “Do-It-Yourself”.

[Example]

Unit: US qt (Imp qt, liters)

Coolant capacity		Outside temperature down to
Non-turbo-charger model	Turbocharger model	
12 (10, 11.3)	12-1/2 (10-3/8, 11.8)	
Anti-freeze	2 (1-5/8, 1.9)	2-1/8 (1-3/4, 2.0)
	4 (3-3/8, 3.8)	4-1/8 (3-3/8, 3.9)
	6 (5, 5.7)	6-1/4 (5-1/4, 5.9)
		19°F (-7°C)
		0°F (-18°C)
		-31°F (-35°C)

BATTERY

If the battery is not fully charged during extremely cold weather conditions, the battery fluid may freeze and damage the battery. To maintain maximum efficiency, the battery should be checked regularly.



DRAINING OF COOLANT WATER

If the vehicle is to be left outside without anti-freeze, drain the cooling system by opening the drain cocks located under the radiator and on the engine block. Refill before operating the vehicle.

For details, refer to “Changing Engine Coolant” under the heading “Do-It-Yourself”.

TIRE EQUIPMENT

1. If you have snow tires installed on the rear wheels of your vehicle, they should be of the same size, load range, construction and type (bias, bias-belted or radial) as the front tires.
2. If the vehicle is to be operated in severe winter conditions, snow tires may be installed on all four wheels.
3. For additional traction on icy roads, studded tires may be used. However, some Provinces and States prohibit their use, so, before installing studded tires, check local, state and provincial laws.

CAUTION:

Skid and traction capabilities of studded tires, on wet or dry surfaces, may be poorer than non-studded snow tires.

SPECIAL WINTER EQUIPMENT

It is recommended that the following items be carried in the vehicle during winter:

1. A scraper and stiff-bristled brush to remove ice and snow from the windows.
2. A sturdy, flat board to be placed under the jack to give it firm support.
3. A shovel to dig the vehicle out of snow-drifts.
4. Snow chains, if desired. Make sure they are installed according to the chain manufacturer's suggestions. In addition, drive at a reduced rate of speed, otherwise, your vehicle may be damaged and/or vehicle handling and performance may be adversely affected.

CORROSION PROTECTION

Chemicals used for road surface de-icing are extremely corrosive and will accelerate corrosion and the deterioration of underbody components such as the exhaust system, fuel and brake lines, brake cables, floor pan and fenders.

Flushing all components at frequent intervals with plain water will greatly reduce the harmful effects of these chemicals.

In areas where heavy concentrations of these corrosive chemicals are used, the vehicle should, in addition to frequent washing, be thoroughly washed, flushed and carefully inspected for signs of deterioration or corrosive action, at least several times per year. Repairs should be performed accordingly.

For additional protection against rust and corrosion, which may be required in some areas, consult your local NISSAN/DATSUN dealer or other competent service facility.



IN HOT WEATHER

REPLACING THE LUBRICANT

When the temperature stays over 90°F (32°C), the engine lubricating oil should be replaced with one of a higher viscosity. Refer to “Recommended SAE Viscosity Number” under the heading “Do-It-Yourself”.

CRUISE CONTROL

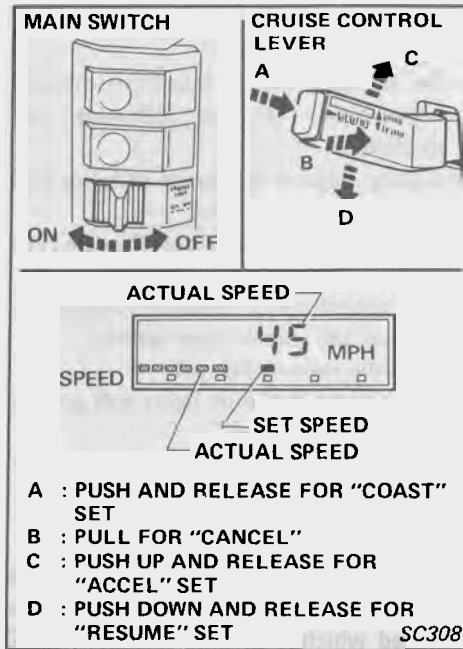

The cruise control system automatically maintains a desired vehicle speed within a range of approximately 30 to 78 MPH (48 to 126 km/h) without the necessity of operating the accelerator pedal.

1. To operate the cruise control, push the main switch to the "ON" position.

[The pilot light (green) on the combination meter panel will illuminate.]

And to set the vehicle at the speed you desire, proceed with either of the following two methods.

The vehicle will then automatically maintain the desired cruising speed.

[The pilot light (blue) on the combination meter panel will illuminate (Needle type meter). The set speed will illuminate in the graphic display on the speedometer (Digital and graphic type meter).]

- a) Depress the accelerator pedal and, when the vehicle attains the desired speed, momentarily press the "COAST" set switch.
 - b) When the vehicle speed is within the range of approximately 30 to 78 MPH (48 to 126 km/h), keep pushing the set lever up, allowing the vehicle to accelerate without depressing the accelerator pedal.
- When the vehicle attains the desired speed, release the cruise control lever.
2. To increase the vehicle speed, briefly depress the accelerator pedal. When the pedal is released, the vehicle will return

to the cruising speed selected prior to acceleration.

3. To reset at a faster cruising speed, proceed with either of the following two methods. The vehicle will then automatically maintain the newly selected speed.

a) Depress the accelerator pedal and, as the vehicle attains the desired speed, momentarily press the "COAST" set switch or push the cruise control lever up.

b) Keep pushing the cruise control lever up, allowing the vehicle to accelerate without depressing the accelerator pedal. When the vehicle attains the desired speed, release the cruise control lever.

4. To reset at a slower cruising speed, proceed with either of the following two methods. The vehicle will then automatically maintain the newly selected speed.

a) Depress the brake pedal and, as the vehicle attains the desired speed, momentarily press the "COAST" or push the cruise control lever up.

b) Keep pressing the "COAST" set switch, allowing the vehicle to decelerate without depressing the brake pedal. When

the vehicle attains the desired speed, release the set switch.

5. To disengage the cruise control, proceed with either of the following two methods.

a) Lightly depress the brake pedal or pull the cruise control lever.

[The blue light will go out. (Needle type meter)

The pre-set speed indicator remains on. (Digital and graphic type meter)]

b) Turn the main switch off.

[Both green and blue lights will go out. (Needle type meter)

The set speed indicator and green light will go out. (Digital and graphic meter type)]

• **The cruise control will automatically be released if the vehicle slows down to a speed which is 6 to 12 MPH (10 to 20 km/h) or more below the pre-set cruise speed.**

• **On the manual transmission model, the cruise control will automatically be released when the clutch pedal is depressed. Never shift the transmission without depressing the clutch.**

• **On the automatic transmission model, the cruise control will automatically be**

released by shifting the control lever into the "N" range.

• **If the brake pedal is depressed while pushing the cruise control lever up, the vehicle speed cannot be set until the main switch is turned "OFF" and then "ON".**

6. To resume the speed selected prior to disengagement of the cruise control by pulling the cruise control lever, depressing the brake or clutch pedal, or by shifting into "N" range on an automatic transmission model, push down and release the cruise control lever.

The vehicle will then automatically return to the speed and maintain it.

• **If the vehicle speed is below 30 MPH (48 km/h) immediately before the "resuming" operation, the "resuming" function will not operate. If the cruise control lever is depressed again when the vehicle speed has exceeded 30 MPH (48 km/h), the "resuming" function will operate.**

• **When the cruise control lever is kept pushed down, the vehicle will decelerate. When the cruise control lever is released, the "resuming" function will start to operate.**

CAUTION:

- Avoid using the cruise control system in areas where road conditions and/or weather elements are not suitable, as in congested areas, very curvy or hilly roads with a short field of vision, slippery roads (rain, snow, ice, etc.), very windy areas, etc.

During cruise-speed driving, keep your foot off the accelerator pedal to permit movement of the accelerator pedal.

- On the manual transmission model, if the transmission is put into the neutral position without the clutch being depressed, and the cruise control is left on, the engine will race and damage will result.

Comfort And Convenience Features

VENTILATION SYSTEM

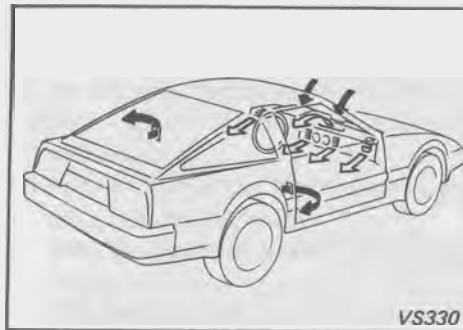

FOR FORCED VENTILATION

Air flow outlets that act like one-way valves are provided in the door locker pillar. When all the windows are closed, they allow air to flow out of the vehicle but not into it, providing constant, draft-free circulation.

When ventilating, refer to the HEATER or AIR CONDITIONER section for operation instructions.

VENTILATORS

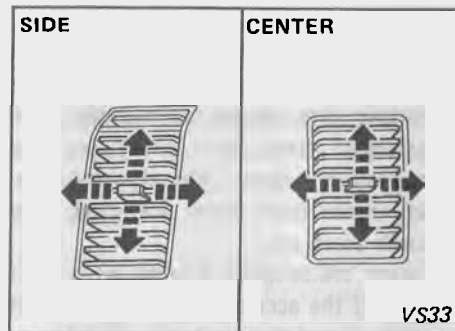

To change the direction of air flow, turn the grille as desired.

HEATER

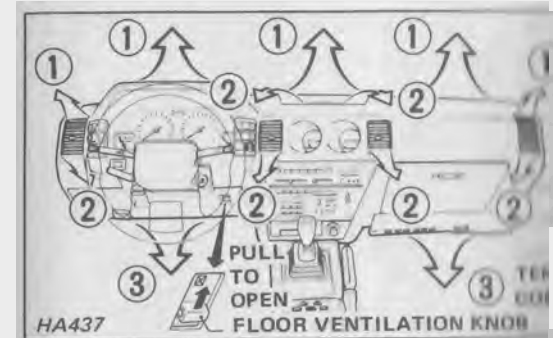

OPERATION

Preferred climate setting	Control position		
	Mode control switch	Temperature control lever	Fan control lever
No heating	Any position	"COLD"	"OFF"
Ventilation		"COLD" to "HOT"	"OFF"
Bi-level			"OFF"
Heating		"COLD" to "HOT"	"OFF"
Defrosting and Heating			"OFF"
Defrosting			"OFF"
Fast heating		"HOT"	"OFF"

HEATER

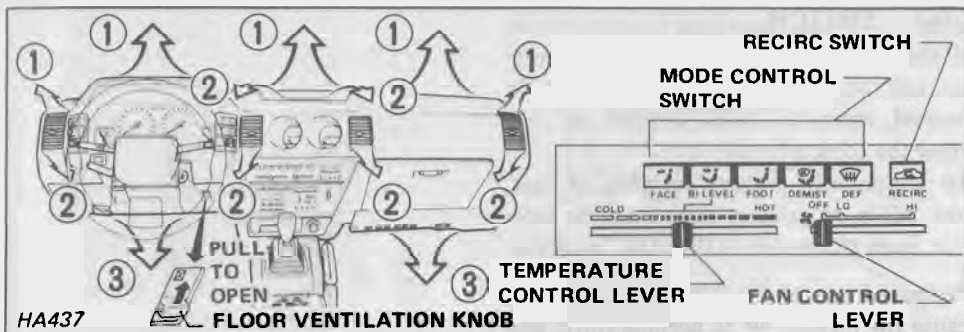

OPERATION

Preferred climate setting	Control position				Air source	Air outlet
	Mode control switch	Temperature control lever	Fan control lever	RECIRC switch		
No heating	Any position	"COLD"	"OFF"	ON	—	No air flow
		"COLD" to "HOT"		OFF	Outside	①
Ventilation		"COLD" to "HOT"	"LO" to "HI"	ON or OFF	Inside or Outside	②
Bi-level						②, ③
Heating						③
Defrosting and Heating						①, ③
Defrosting				OFF	Outside	①
Fast heating		"HOT"	"HI"	ON	Inside	③

FLOOR VENTILATOR KNOB

When the floor ventilator is pulled up with the MODE control switch at the "FACE" position, the air will be directed toward the floor area as well as the face area.

OPERATING TIPS

- Clear any snow and ice from the air inlet in front of the windshield to improve heater and defroster efficiency.
- Always remove snow and ice from the front, side and rear windows to improve defogging efficiency and ensure proper visibility.
Remove snow and ice from the outside mirrors and lights at the same time.
- For adequate rear seat heating, keep the floor areas beneath the front seats clear, and operate the fan as required.



SWITCH

If the switch is pressed to “ON”, interior air will be recirculated. If the switch is pressed again to “OFF”, outer air will enter the compartment.

To temporarily prevent entrance of dust, bad odors or exhaust gases into the interior, push the switch to the “ON” position.

Prolonged use of the “ON” position may cause the interior air to become stuffy and the windows to fog up. To prevent these, usually, the “OFF” position should be used.

AIR CONDITIONER *Manual control)* control)

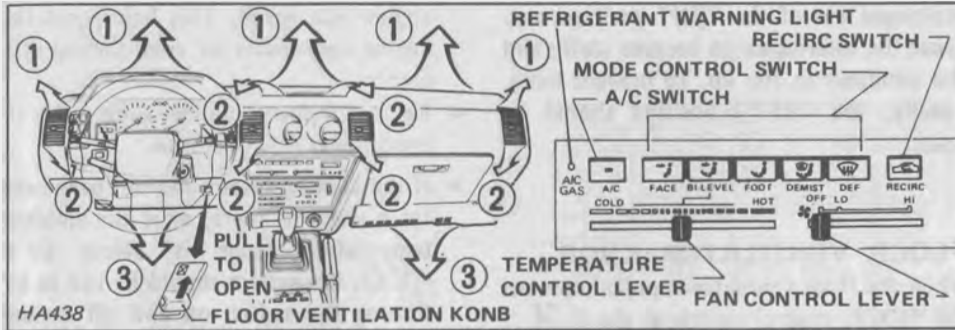

OPERATION

Preferred climate setting	Control position				Air source	Air outlet
	Mode control switch	Temperature control lever	Fan control lever	RECIRC switch		
Cooling and Dehumidified heating		"COLD" to "HOT"	"LO" to "HI"	"ON" or "OFF"	Inside or Outside	②
						②, ③
						③
						①, ③
Dehumidified defogging				OFF	Outside	①
Ventilation Heating Defrosting*	Utilize the same procedure as for the HEATER.					

*: If it is difficult to defrost the windshield glass while the A/C switch is turned off, turn it on.

AMH00651

A/C SWITCH

To operate the air conditioner system, push the A/C switch to "ON" and move the FAN CONTROL LEVER from "LO" to "HI". The air conditioner indicator light on the A/C switch will come on.



REFRIGERANT WARNING LIGHT

This warning light indicates that the refrigerant capacity in the air conditioner system is low.

This light should glow when the ignition switch is "ON" (engine off) and will go out when the engine is started.

If it stays on during normal driving speed, stop the air conditioner and contact your NISSAN/DATSUN dealer or other competent service facility.

CAUTION:

Continued operation of the air conditioner when the refrigerant warning light is on may damage the air conditioner system.



SWITCH

If the switch is pressed to "ON", interior air will be recirculated. If the switch is pressed again to "OFF", outer air will enter the compartment.

To temporarily prevent entrance of dust, bad odors or exhaust gases into the interior, push the switch to the "ON" position.

Prolonged use of the "ON" position may cause the interior air to become stuffy and the windows to fog up. To prevent these, usually, the "OFF" position should be used.

FLOOR VENTILATOR KNOB

When the floor ventilator is pulled up with the MODE control switch at the "FACE" position, the air will be directed toward the floor area as well as the face area.

OPERATING TIPS

Tips other than the following are the same as those for the heater.

- If your vehicle has been parked in the sun for a period of time with all the windows closed, drive for two or three minutes with all windows open. This will allow the air conditioner to cool the interior more quickly, as the hot air will be forced from the vehicle.
- If stopped in traffic during hot weather, place the automatic transmission lever in PARK "P" position to increase the

engine idle speed. This helps cool the engine and assists air conditioning efficiency.

- Keep windows closed while the air conditioner is in operation.
- **If the cooling system has not been used for a week or more, or if the ambient temperature range is below 60°F (15°C), the system should be run in by turning the switch on and off several times at three second intervals, with the engine running at low speed. This will add to the service life of the system.**
- **If anything unusual is noted, shut off the system immediately. Have it checked by your NISSAN/DATSUN dealer or other competent service facility.**
- **It is suggested that the system be run for about ten minutes or so at least once a month in winter to circulate lubricant in the system, so that it will be ready for use next season.**
- **At the start of the season, it is recommended that the air conditioning system be checked by your NISSAN/DATSUN dealer or other competent service facility.**



AIR CONDITIONER (Auto temperature control)

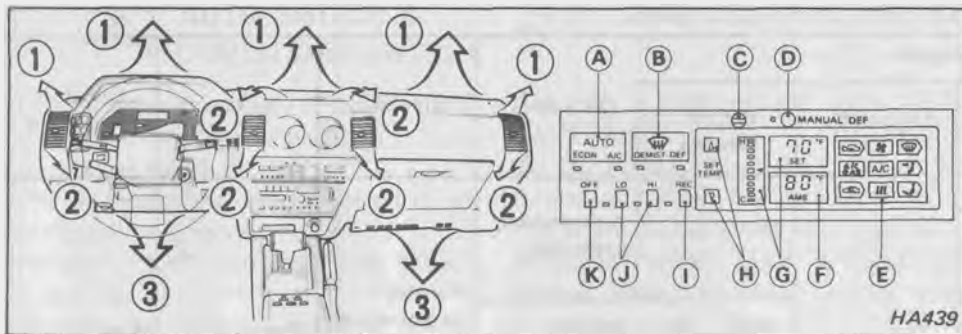



- (A) AUTO switch
- (B) DEMIST-DEF switch
- (C) SET TEMP adjuster
- (D) MANUAL DEF switch
- (E) A/C operating monitor

- (F) AMB temperature indicator
- (G) SET temperature indicator
- (H) SET TEMP switches
- (I) REC switch
- (J) FAN control switches
- (K) OFF switch

The auto temperature control is an air conditioning system which, once the SET TEMP switches are set to a desired temperature position, automatically selects the optimum air flow, outlet air temperature and outlet port so that the interior temperature can be maintained at the desired temperature, irrespective of changes in outside air temperature.

A/C OPERATING MONITOR

-  Indicates air is discharged from the vents (1) to the windshield in order to remove condensation and frosting.
-  Indicates air is discharged from the ventilators (2).
-  Indicates air is discharged from the vents (3) to the foot area.



Indicates the blower motor is operating.



Indicates the A/C compressor is operating.



Indicates hot water is flowing to the heater core through the water cock.



Indicates outside air is being taken in.



Indicates the inside air is used as the air source.



This warning light indicates that the refrigerant capacity in the air conditioner system is low.

This light should glow when the ignition switch is "ON" (engine off) and will go out when the engine is started.

If it stays on during normal driving speed, stop the air conditioner and contact your NISSAN/DATSUN dealer or other competent service facility.

CAUTION:

Continued operation of the air conditioner when the refrigerant warning light is on may damage the air conditioner system.

OPERATION

Preferred climate setting	Control position				Air source	Air outlet	Air flow	Outlet air temperature
	AUTO/DEMIST-DEF/MANUAL DEF switches	Set temperature	Fan control switches	RECIRC switches				
Ambient temperature is cool	AUTO w	"ECON"	Any temperature	"LO", "HI" or Automatic control	OFF	Automatically controlled	Variable (Automatically controlled)	Variable (Automatically controlled)
All seasons		"A/C"			ON*1	Inside*1		
Normal defrosting	MIST-switch	"DEMIST"			Automatically controlled	① and ③		
Fast defrosting	MANUAL DEF switch*5	"DEF"			OFF	Outside*2	①	LO or HI*3
		ON				HI		

- *1: Approximately 10 minutes after the RECIRC switch has been turned on, it will automatically turn off and the air source will be automatically controlled.
- *2: The air source is automatically fixed at "Outside".
- *3: When the "DEF" mode is selected, the amount of air flow is automatically controlled to "HI". "LO" air flow can be selected by depressing the "LO" switch.
- *4: When the "DEF" mode is selected, the outlet air automatically rises to the maximum temperature.
- *5: This switch should be used only if the air conditioner control function should be out of order.



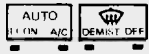

AUTO SWITCH & DEMIST-DEF SWITCH

Pushing either the AUTO or DEMIST-DEF switch activates the air conditioner when the ignition switch is “ON”.

The air conditioner can then be set to any of the following modes:

“ECON”, “A/C”, “DEMIST”, and “DEF”, as needed.

The selected mode is indicated by the corresponding pilot light on the control panel.

When the DEMIST-DEF switch is set to “DEF”, the FAN control switch is automatically set to the “HI” position. Pushing the “LO” switch allows for a low air flow rate.

When the AUTO switch is pushed to “A/C”, or when the set temperature is changed during the “A/C” mode, an electronic sound will emit three times when the outside temperature is lower than about 60°F (15°C). This is a sign suggesting the AUTO switch can be set to “ECON”. When the “ECON” mode is selected, it is economical as the A/C compressor stops.



FAN CONTROL SWITCH

The FAN control switch is set to “OFF”, “AUTOMATIC”, “LO” or “HI” by pressing the buttons. When the “LO” or “HI” button is pushed, the pilot light on the left of the corresponding button comes on. When the button which is operating is pushed again, the fan control is set in the automatic mode and the speed of the fan motor is automatically controlled.



OFF SWITCH

When the switch is depressed while the air conditioner is operating, it will stop. To operate the air conditioner, depress the AUTO switch or DEMIST-DEF switch.



SETTING THE TEMPERATURE

The temperature can be set as desired by means of two SET TEMP switches. Pushing the upper switch increases the set temperature; pushing the lower switch decreases it. The set temperature is shown on both the graphic and digital displays.

When the DEMIST-DEF switch is set to “DEF”, the set temperature will rise to the maximum temperature. In any other mode, the set temperature returns to the last set temperature.

The outside temperature is also shown on the digital display.



REC SWITCH

When the switch is pressed to “ON”, interior air will be recirculated. The indicator light on the left side of the switch will come on. If the switch is pressed again to “OFF”, outer air will enter the compartment.

To temporarily prevent entrance of dust, bad odors or exhaust gases into the interior, push the switch to the "ON" position. The REC switch is deactivated when the DEMIST-DEF switch is in "DEF".

Prolonged use of the "ON" position may cause the interior air to become stuffy and the windows to fog up. To prevent these, usually, the "OFF" position should be used.



SET TEMP ADJUSTER

The SET TEMP adjuster is used to create a difference in temperature between the head area and foot area, as desired. When the adjuster is turned counter-clockwise (with a screwdriver or similar tool), the temperature around the head area decreases and that around the foot area increases; when it is turned clockwise, the temperature around the head area increases and that around the foot area decreases.

NOTE:

When the outside temperature is higher than 60°F (15°C), there will not be a difference in air temperature between the side ventilator outlets.

MANUAL DEF SWITCH

Pushing the switch once will activate the system in the "DEF" mode removing moisture from the windshield. Pushing the switch again releases the "DEF" mode. The pilot light to the left of the switch comes on when the switch is on.

During this mode of operation, the air conditioning system and display panel will be inoperative.

This switch should be used only if the air conditioner control function should be out of order.

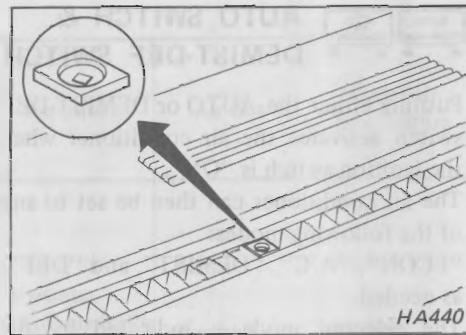

SUNLOAD SENSOR

The sunload sensor, which is part of the auto temperature control air conditioner system, is located on the top surface of the instrument panel. Do not put items on or around this sensor. Otherwise, the auto temperature control air conditioner may not operate normally.



OPERATING TIPS

Tips other than the following are the same as those for the heater.

- If your vehicle has been parked in the sun for a period of time with all the windows closed, drive for two or three minutes with all windows open. This will allow the air conditioner to cool the interior more quickly, as the hot air will be forced from the vehicle.
- If stopped in traffic during hot weather, place the automatic transmission lever in PARK "P" position to increase the engine idle speed. This helps cool the engine and assists air conditioning efficiency.
- Keep windows closed while the air conditioner is in operation.
- If the cooling system has not been used for a week or more, or if the ambient temperature range is below 60°F (15°C), the system should be operated by turning the switch on and off several times at three second intervals, with the engine running at low speed. This will add to the service life of the system.
- If anything unusual is noted, shut off the system immediately. Have it checked by your NISSAN/DATSUN dealer or other competent service facility.

AMH100657

- It is suggested that the system be operated for about ten minutes or so at least once a month in winter to circulate lubricant in the system so that it will be ready for use next season.
- At the start of the air conditioner season, it is recommended that the air conditioning system be checked by your NISSAN/DATSUN dealer or other competent service facility.
- When the engine is cold, the air conditioner operates in the "DEF" mode until the engine has warmed up.
- The air conditioner compressor remains inoperative when the outside air temperature is lower than 32°F (0°C).
- If the ignition switch is put in the "ON" position even when the air conditioner is stopped, the displays will come on. When the engine runs, the indications except the AMB temperature and SET temperature indicators will go out.



RADIO AND STEREO TAPE DECK

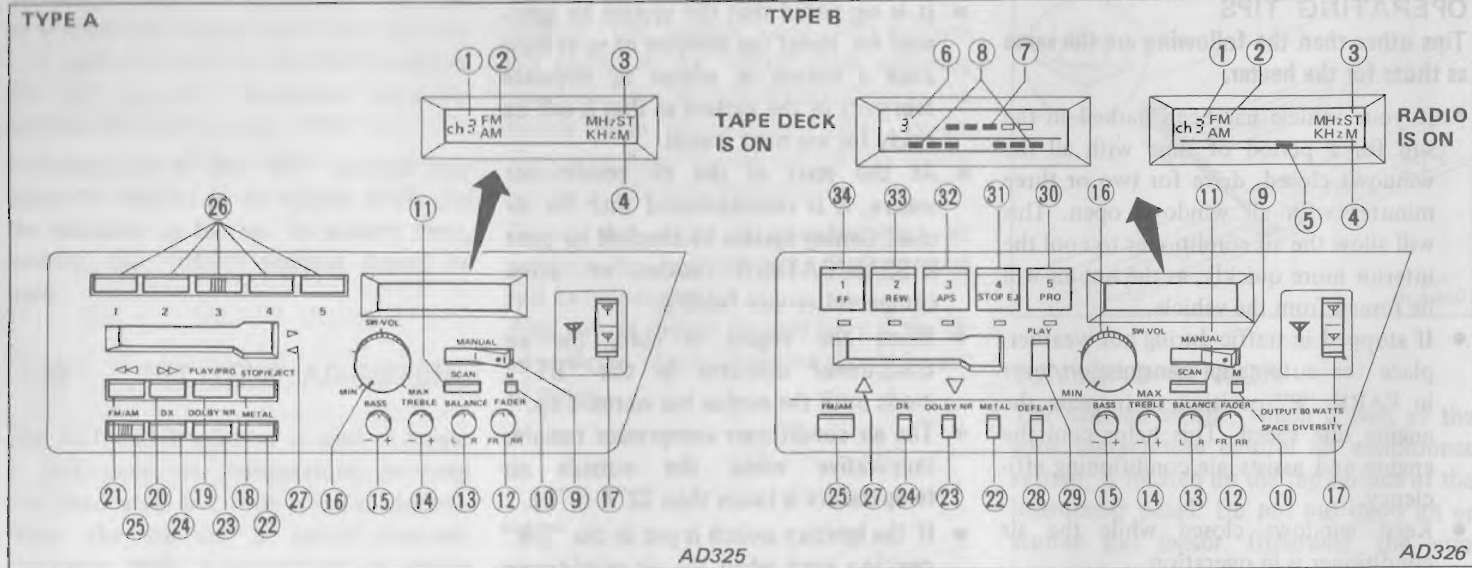

AD325

AD326

- ① Channel indicator
- ② AM-FM indicator
- ③ Stereo indicator
- ④ Memory indicator
- ⑤ Frequency indicator
- ⑥ Tape program search indicator
- ⑦ Remaining cassette tape amount indicator
- ⑧ Cassette output level indicator
- ⑨ Manual turning switch
- ⑩ Memory button
- ⑪ SCAN tuning switch
- ⑫ FADER control knob
- ⑬ BALANCE control knob

AMH00658

- ⑭ TREBLE control knob
- ⑮ BASS control knob
- ⑯ Power ON-OFF switch and volume control knob
- ⑰ Antenna height switch
- ⑱ Stop and eject button
- ⑲ Play and program select button
- ⑳ Fast rewind button
- ㉑ Fast forward button
- ㉒ Tape selector
- ㉓ Dolby button
- ㉔ SCAN tuning sensitivity selector

- ㉕ AM-FM band selector
- ㉖ Tuning push button
- ㉗ Tape operating indicator
- ㉘ DEFEAT button
- ㉙ Play button
- When radio is on —
- ㉚ to ㉜ Tuning push button
- When tape deck is playing —
- ㉝ Program select button
- ㉞ Stop and eject button
- ㉟ Auto program search button
- ㊱ Fast rewind button
- ㊲ Fast forward button

RADIO

The radio features an automatic tuning system and five push buttons for station selection. Using the push buttons, it is possible to preset five FM stations and five AM stations. Other stations may be selected using the SCAN or manual tuning switch. The ignition switch must be set at "ON", or "ACC". The stereo indicator remains lighted during FM stereo reception. The channel indicator indicates channel number of tuning push button and continues to glow during reception.

Type B

In addition to the digital frequency display, a frequency indicator in the lower section lights up to indicate the frequency.

- **When receiving a stereo broadcast in mountainous areas, etc. where FM is weak, the radio will automatically change from stereo to monaural to prevent static from entering the radio. At this time, the stereo indicator shuts off.**

MANUAL tuning

AM frequency will continue to increase or decrease in units of 10 kHz, and FM frequency in units of 0.2 MHz by keeping the right or left side of the switch pressed down.

SCAN tuning

When the SCAN tuning switch is pressed, scanning begins from low to high frequencies. When any station is received, the scan stops for five seconds. If nothing is done by the listener during this period, scanning starts again.

If the switch is again pressed during this five second period, the radio remains tuned to that station even after the switch is released. This scanning motion can be restarted by pressing the switch again.

SCAN tuning will continue if the broadcasting station is exceptionally weak. In such a case, set the SCAN tuning sensitivity selector button to the "DX" () position. For normal use, set the button in the "LO" () position.

Speaker balance control

Adjust the right and left speaker volume by turning the BALANCE control knob.

Adjust the volume for the front and rear speakers by turning the FADER control knob.

The point where a light click is felt is the center position.

Tone control

Turn the BASS or TREBLE tone control knob clockwise or counterclockwise, as desired, to adjust the tone. Turning the control knob clockwise will gradually increase the tone, while turning it counterclockwise will cause the tone to become softer.

The point where a light click is felt is the center position.

Pressing the DEFEAT button () will change the sound to a normal tone regardless of the BASS or TREBLE knob position. If the button is pressed again (), the DEFEAT function will be cancelled and the sound will become the original tone.



SETTING PUSH BUTTONS

Depending on the AM-FM band selector position, the desired AM or FM stations can be set by tuning push buttons 1 through 5.

1. Select the desired station by automatic or manual tuning.
 2. Lightly press the desired tuning push button while also pressing the memory button. This will cause the previously memorized station to be cancelled and replaced by the newly selected station.
 3. Other tuning push buttons can be set to desired stations in the same manner.
- **The memory indicator will remain lighted for five seconds after the memory button is pressed. If the push button is pressed during this period, the desired station can be set.**
 - **When the battery cable is disconnected, when the radio is removed, or when the fuse in the power circuit blows, the memory will also be cancelled. In that case, reset the desired stations.**

POWER ANTENNA

Turning on the power switch with the ignition switch set at "ON" or "ACC", the antenna will automatically extend.

The antenna will automatically retract when the power ON-OFF switch is off.

The antenna height switch permits the selection of antenna height in two stages.

When the antenna height switch is pushed on the down end, the antenna will extend to half height. When pushed on the up end, the antenna will extend to full height.

WARNING:

- **Before turning on power to the radio, make sure that there is no one near the antenna outlet and there is enough space for it to extend.**
- **When receiving an FM broadcast near an FM station where a number of other FM stations are geographically located close by, set the antenna at half height so that good reception can be obtained.**

STEREO TAPE DECK (Cassette)

Turn the ignition key to the "ON" or "ACC" position and insert the tape cassette gently through the tape door.

- To play the deck, push the play button. When playing, the tape operating indica-

tor will come on. The tape cassette contains two programs which are automatically played in succession. If the stereo tape deck is operated when the radio is turned "ON", the power supply for the radio tuner will be automatically cut off.

- To select a program, push the program select button. To rapidly select a particular program, push the fast forward or rewind button.
- Volume, tone and speaker balance adjustments are made with the radio controls and adjustment procedures.
- To stop, push the stop and eject button.
- To remove the tape, stop the tape deck and push the stop and eject button.
- **When the PLAY button is pushed while the tape is in fast forward or the radio is on, the tape will be played.**
- **When the power ON-OFF switch is pushed while the tape is playing, it will stop playing the tape and the radio will come on.**

Bar graph display (Type B)

The display indicates the amount of tape remaining and output power level in a graphic bar.

Auto program search (Type B)

For music tapes, automatic search can be done up to nine selections ahead or before. While the tape is playing, check what number the selection to be searched is and push the auto program search button until the number desired appears on the left side of the display. Next, press the fast forward button or fast rewind button. The tape will run quickly and stop just the desired selection and then play.

When the SCAN tuning switch is pushed while playing a tape, the tape will run quickly and return to the normal speed just before the next program. The tape will play for 10 seconds and then run quickly again; these sequences will be repeated until the SCAN tuning switch is pushed during the 10 seconds of normal play. When the SCAN tuning switch is pushed, the tape will continue to play at normal speed.

This system searches the desired selection by counting the blank intervals between selections. Therefore, if there is a blank interval within one selection or there is no interval between selections, the system may not search correctly.

- When playing a tape recorded with a "Dolby" system, press the "Dolby" button. When the "Dolby" is on (), high frequency tape noise will be reduced. When the button is pressed again, "Dolby" will be turned off. ()
- When playing a high performance tape (metal tape or chrome tape), be sure to depress the tape selector button. () Press the button again to set the tape deck in the normal position. ()
- Use the "Dolby" button and tape selector according to the tape you wish to hear. Incorrect changeover will diminish the sound quality.
- When the vehicle has been parked in a hot or humid place, run the vehicle for some distance before starting the stereo tape. Never leave a cassette in the player when it is not being used.
- Store the tape in a cool, clean and dry place in the shade, with the tape end of the cassette in an upright position.
- When the ignition key is turned "OFF" while playing the stereo tape deck, the stereo tape deck will stop and pinch roller will come off the tape.

- Dolby and the double-D symbol are trademarks of Dolby Laboratories Licensing Corporation.

Cleaning: After being used for a long time, the head of the deck will be covered with dust and tape powder.

This residue may cause a deterioration of the sound quality and output of the tape.

Push open the tape door and clean the capstan (revolving metal post), head and tape guide with alcohol (do not use carbon tetrachloride).

CB RADIO OR CAR PHONE

CLOCK

When installing large capacity wireless equipment or a car phone in your NISSAN, be sure to observe the following as it may adversely affect the E.F.I. system and other electronic parts depending on its installation location.

- Keep the antenna as far as possible away from the Electronic Control Unit.
- Also keep the antenna feeder line as far as possible away from the E.F.I. harness [7.9 in (20 cm) min.]. Do not make them parallel for a long distance.
- Adjust the antenna and feeder line so that the standing-wave ratio can be kept smaller.
- For details, consult a NISSAN/DATSUN dealer or other competent service facility.

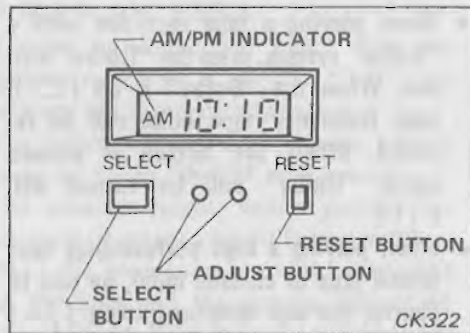

The time is displayed when the ignition switch is in the "ACC" or "ON" position, or the light switch is in the "ON" position. The clock continues operation even when the ignition switch is in the "OFF" or "LOCK" position, though the time is not displayed. The digital clock display will change as follows when the "SELECT" button is pressed.

"Hours and minutes" → "Month and day"
→ "Minutes and seconds" → "Hours and minutes" → ...

However, the display of "month and day" will automatically return to "hours and minutes" within several seconds.

Once the power supply is disconnected the clock will continue to flash 12:00 in hours

and minutes or the date 1 1 (Jan. 1). In this case, pressing the adjust button will start the clock running again.

The adjust button is designed so that it cannot be pressed with a finger. When adjustment is necessary, press the adjust button with a pointed article such as a pencil. This is designed to prevent an accidental adjustment.

To adjust the clock, proceed in the following manner.

Hour and minute display

1. Press the "SELECT" button and set the digital display to "hours and minutes". For example, 10:45. In this case, the colon located in the middle of the digits flashes.
2. Press the left adjust button and adjust to the desired hour with the AM/PM indicator lighted.
3. Keep pressing the right adjust button and adjust to the desired minute.

Calendar (Month and day) display

1. Press the "SELECT" button and set the digital display to "month and day". For example 2 1 (Feb. 1). In this case, the colon located in the middle of the digits disappears.

2. Press the left adjust button and set to the desired month. The meanings of the numerals for the months are:

- | | |
|--------------|--------------|
| 1: January | 2: February |
| 3: March | 4: April |
| 5: May | 6: June |
| 7: July | 8: August |
| 9: September | 10: October |
| 11: November | 12: December |

3. Press the right adjust button and set to the desired day.

Minute and second display

Press the "SELECT" button and set the digital display to "minutes and seconds". For example 10:10 (10 minutes 10 seconds). In this case, the center colon remains lit.

If the "RESET" button is pressed when the clock displays "minutes and seconds", the display will start from 00:00.

Time adjustment

When the clock displays either "hours and minutes" or "minutes and seconds", the clock can be set to the time signal.

For example, if the "RESET" button is depressed while the time is between 8:01 and 8:29, the display will be reset to 8:00. If depressed while it is between 8:30 and 8:59, the display will be reset to 9:00.

AMH00663

CIGARETTE LIGHTER AND ASH TRAYS

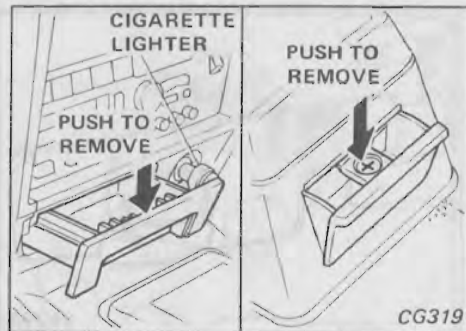

CIGARETTE LIGHTER

Push the knob in all the way and release it. When the lighter springs back to its original position, it is ready for use.

Replace the lighter in its original position after use.

ASH TRAYS

Do not use the ash tray as a waste receptacle.

GLOVE BOX AND BODY SIDE POCKET

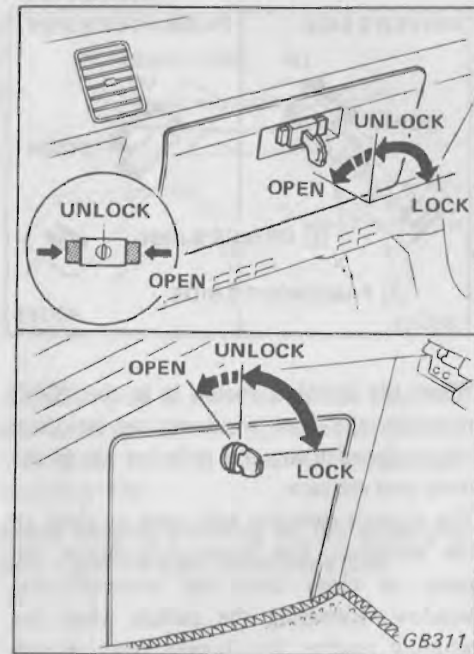

The glove box and body side pocket provide handy storage space.

When locking or unlocking the glove box, use the master key. The security key cannot be used.

Keep glove box lid closed while driving to prevent injury in an accident or a sudden stop.

POWER WINDOW

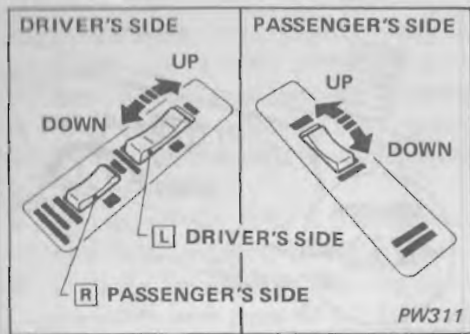

When the ignition switch is in the "ON" position, the door windows can be opened or closed using the switches set in the door arm restraint.

The driver's switches will open or close all the windows. The passenger's switch will open or close only the corresponding window. Releasing the switch when the window reaches the desired position will cause the window to stop.

WARNING:

To assure the safety of children and others, make sure that all passengers have their hands, etc. inside the vehicle before closing the windows. Also, be sure to remove the ignition key and keep it with you when you leave the vehicle.

AMH00664

SUN VISORS AND VANITY MIRROR

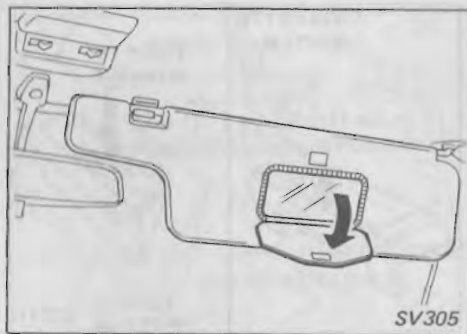

You can lift the sun visors from their center mounting and turn them toward the windows to block glare from the sides. The vanity mirror is located behind the passenger sun visor.

INTERIOR LIGHT

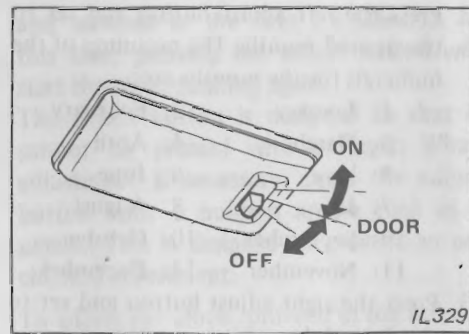

INTERIOR LIGHT

To turn on the interior light, flip the switch to the "ON" position.

When the knob is in the "DOOR" position, the interior light will be turned on (off) automatically by opening (closing) the rear hatch (2-seater model), driver's or passenger's door.

Interior light delay system

On models which are equipped with this system, when doors are closed and the interior light switch is set at "DOOR", the interior light will gradually fade to "OFF".





SPOT LIGHT

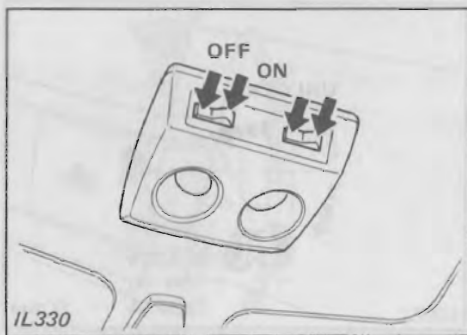

To turn on the spot light, push the switch. To turn off the light, push the switch again. The spot light will be helpful for reading road maps, instructions, etc. in the vehicle at night.

ASSIST GRIPS AND COAT HANGERS

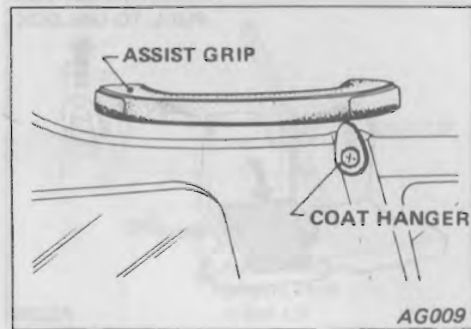

An assist grip is attached to the roof rail above the side window [2+2 model (except T-bar roof model)] and to the passenger side door trim.

Avoid hanging anything on the assist grip that might obstruct the driver's view.

Illuminated entry system

On models which are equipped with this system, the interior light when the interior light switch is set at "DOOR", leg room lights and door key cylinder illumination will come on and gradually go out when the outer handle of the driver's door is pulled and released once. This operation will allow you to check the interior of the vehicle and to aid for inserting the key into the door key hole from the outside before unlatching the door lock when entering the vehicle at night.

FOLDING REAR SEAT

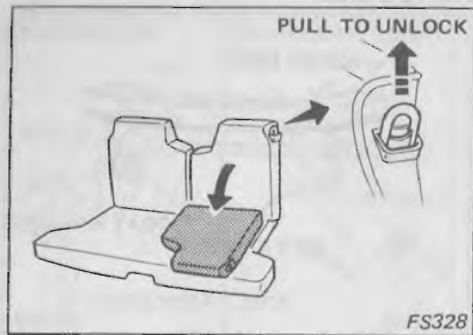

2+2 MODEL

The rear seat may be quickly and easily converted into luggage space when needed. The right and left rear seat backs can be folded down separately. Release the lock at the outer side of each seat back, and then pull the seat back forward and down to expand the luggage space.

- When the seat back is in its normal upright position, make sure it is locked securely.
- Never allow anyone to ride in the luggage area or on the rear seat in the fold-down position. Use of these areas by passengers can be extremely hazardous.

REAR HATCH LOCK

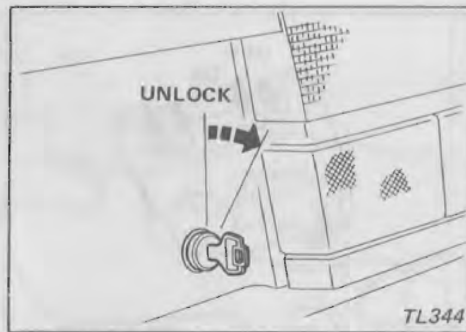

To open the rear hatch, insert the key and turn it clockwise. To lock the rear hatch, push it down securely. No further key operation is required.

CAUTION:

Do not drive with the rear hatch open. This will prevent dangerous exhaust gases from being drawn into the vehicle.

If the vehicle is driven with an open or unsecured rear hatch, it could become damaged through uncontrolled movement.

REAR HATCH AND FUEL FILLER LID OPENER

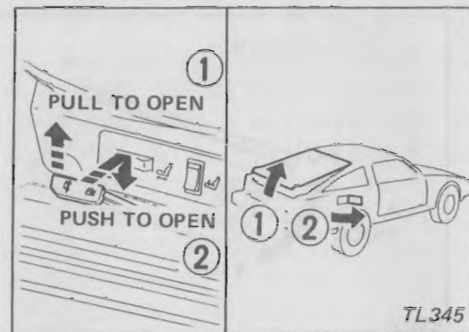

The rear hatch or fuel filler lid can be opened from the driver's seat without a key. To open the rear hatch, pull up the opener lever located in the left of the driver's seat to release the lock. To open the fuel filler lid, push the opener lever down. To lock, push the rear hatch or fuel filler lid down securely.

Turn off the engine while refueling.

CAUTION:

Do not drive with the rear hatch open. This will prevent dangerous exhaust gases from being drawn into the vehicle.

If the vehicle is driven with an open or unsecured rear hatch, it could become damaged through uncontrolled movement.

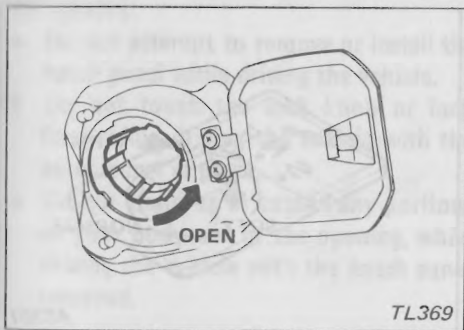

FUEL FILLER CAP

The fuel filler cap is a screw-on ratcheting type.

To remove the fuel filler cap, rotate it counterclockwise. To install the fuel filler cap, tighten it clockwise securely until a ratcheting clicking sound is heard indicating the cap is completely on.

- Turn off the engine while removing the fuel filler cap.
- Use only a genuine NISSAN fuel filler cap specified for your model. It has a built-in safety valve to prevent a serious malfunction of the fuel system and emission control system.

AMH00667

TILTING STEERING WHEEL

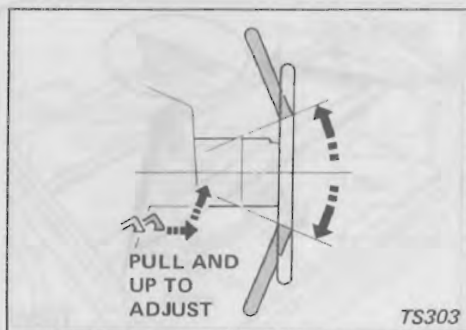

TILT OPERATION

The steering wheel can be tilted to obtain the best driving position.

To tilt the wheel, first unlock the steering column by pulling the lock lever out and up.

Then, while keeping the lever up, move the steering wheel up or down to the desired position.

To lock the wheel, release the lever and the lever will return to the original position.

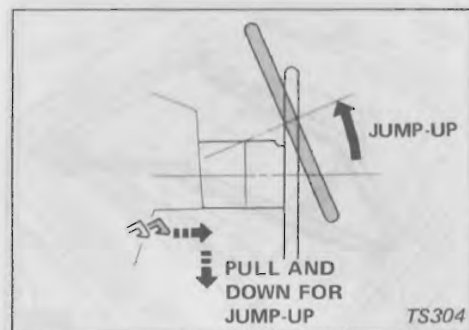

JUMP-UP OPERATION

The steering column can be jumped-up to enable the driver easy entry into the vehicle.

To jump-up the wheel, unlock the steering column by pulling the lever out and down. The steering wheel will then jump-up automatically. After sitting in the seat, bring the wheel down.

The wheel will lock in the original position.

CAUTION:

Do not adjust the steering wheel while driving.



BAGGAGE STRAP

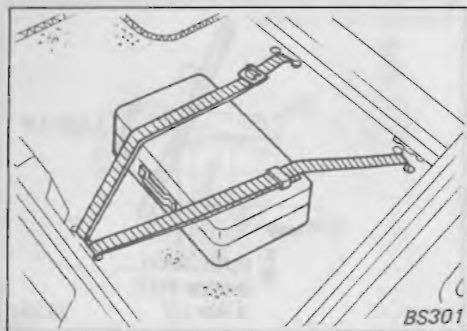

There is a strap in the baggage space to secure baggage while traveling. Use of the baggage strap to secure baggage will help keep it from being thrown about and injuring occupants in an accident.

Luggage or other cargo should not be placed in a manner which will obstruct the driver's rear or side vision.

TONNEAU COVER

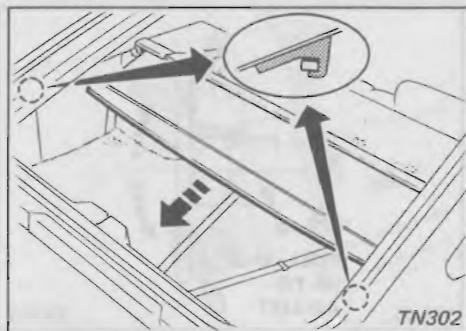

The tonneau cover keeps the luggage compartment contents hidden from the outside.

Never put anything on the tonneau cover, no matter how small. Any object on it could cause an injury in an accident or when the brakes are applied suddenly.

ADJUSTABLE SHOCK ABSORBER SWITCH

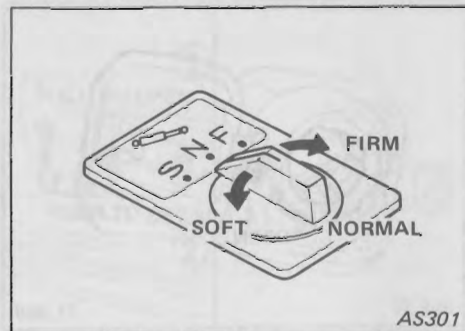

The damping force of the shock absorbers can be set at the level you desire by the switch on the center console. The indicator light (green) on the selected position will illuminate.

Marks "S", "N", and "F" on the switch stand for "Soft", "Normal" and "Firm", respectively.

The switch can be switched over only when the ignition switch is in the "ON" position.

When the system is normal, only the indicator light for the selected position will come on. If any other condition exists, (for example, all the three indicator lights come on or go off, or any of the lights flickers), it shows that there is an abnormality. Should this occur, contact your NISSAN/DATSUN dealer or other competent service facility and have it checked.

T-BAR ROOF

WARNING:

- Do not attempt to remove or install the hatch panel while driving the vehicle.
- Do not touch the lock knob or lock lever while driving the vehicle with the hatch panel in place.
- Do not stand up or extend any portions of your body out of the opening, while driving the vehicle with the hatch panel removed.

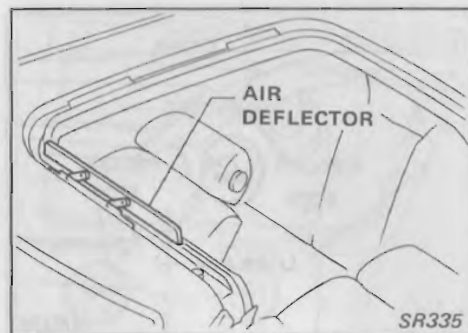
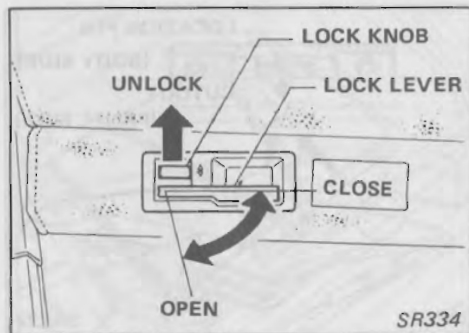

REMOVING THE HATCH PANEL

1. While pushing up the lock knob, pull the lock lever to its fully open position.
2. Lift the hatch panel and remove it from the vehicle.

When removing the hatch panel, securely support it using both hands so as not to drop it.

CAUTION:
Do not attempt to put hot water on a frozen air deflector in cold weather.

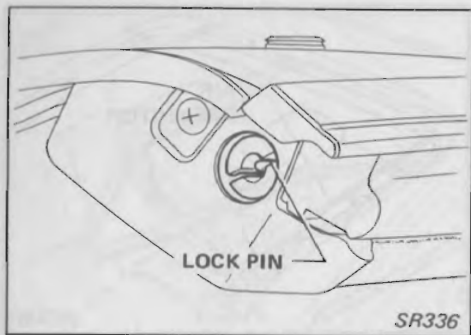

INSTALLING THE HATCH PANEL

1. Move the lock lever to its fully open position.

Ensure that the end of the lock pin does not protrude from the roof garnish.

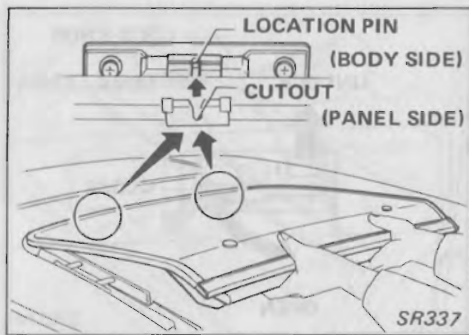

2. Properly align the cutout portion of the sash on the hatch panel with the locating pin of the hook on the vehicle body, and insert the hatch panel into the hook.

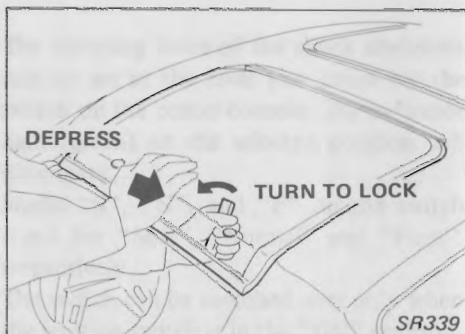
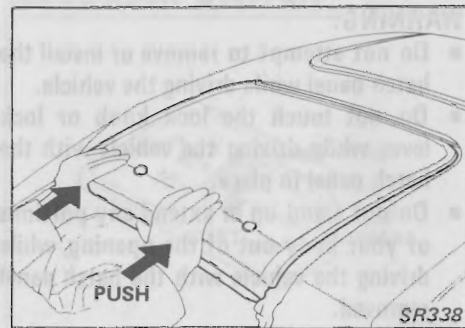

3. To firmly place the hatch panel in position, push the hatch panel towards the middle of the vehicle.
4. Lower the entire hatch panel. While depressing the hatch panel finisher, gradually move the lock lever in the direction that tightens the hatch panel.

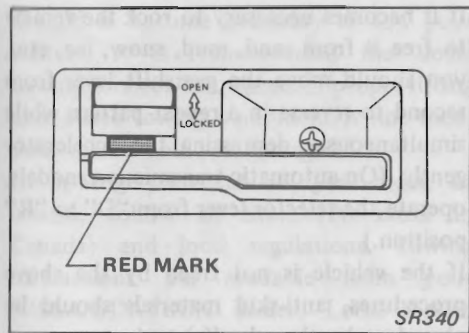

Carefully depress the finisher until the sash is even with the height of the vehicle, being careful not to scratch the trim with the lock pin.

5. Gradually move the lock lever towards its lock position until the knob “clicks”.

After the hatch panel has been properly installed, ensure that the lock knob covers the “RED” marks.

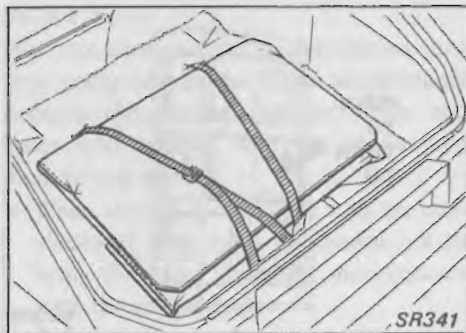

STORING OF PANELS

After removing the hatch panel, store it in the luggage compartment according to the following procedures:

1. Insert the hatch panel into its protective bag.
 2. Securely fasten the hatch bag using the baggage straps.
- To correctly store the left and right hatch panels, place one hatch panel over the other with their locks positioned symmetrically to prevent scratching the panels.
 - Do not place any heavy objects or items which have pointed corners or sharp edges on the stored panels.

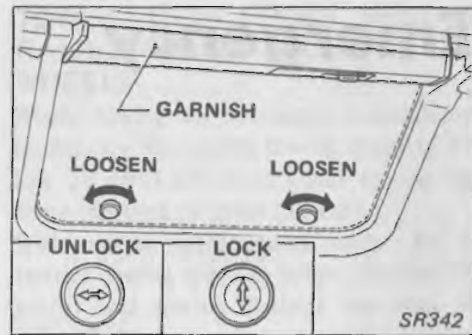

SUN SHADE PLATE

Removal

1. Loosen the bolts while holding on to the sun shade plate.
2. Unfasten the hooks on the sun shade plate from the holders.

Installation

1. Insert the outside edge of sun shade plate into the garnish.
2. Align two bolts on inside of sun shade plate with locknuts and then securely tighten the bolts.

CAUTION:

Do not attempt to remove the sun shade while the vehicle is in motion.

In Case Of Emergency



HAZARD WARNING



Use the hazard warning flasher to warn other drivers that your vehicle is disabled or parked under emergency conditions. Avoid stopping the vehicle on the roadway if possible. For further instructions, refer to "Hazard Warning Flasher Switch" under the heading "Instruments and Controls".

FREEING IMMOBILIZED VEHICLE

If it becomes necessary to rock the vehicle to free it from sand, mud, snow, ice, etc., you should move the gearshift lever from second to reverse in a repeat pattern while simultaneously depressing the accelerator gently. (On automatic transmission models, operate the selector lever from "D" to "R" position.)

If the vehicle is not freed by the above procedures, anti-skid materials should be placed under the wheel(s) to improve traction or the vehicle should be towed out.

CAUTION:

To get the best possible traction under such circumstances, avoid racing the engine.

Personal injury and vehicle damage, including tire and/or rear axle failure, may result from excessive wheel spinning.

TOWING THE VEHICLE

Should it become necessary to tow your vehicle, it is recommended that local towing services be utilized. If proper lifting and other towing equipment is not used, your vehicle could be damaged.

In towing your vehicle, you must, of course, follow all State (Provincial in Canada) and local regulations. Towing instructions are available from your NISSAN/DATSUN dealer. Local service operators will generally be familiar with the applicable laws and procedures for towing. To assure proper towing and to prevent accidental damage to your vehicle, it is advisable to have the service operator carefully read the following precautions.

CAUTION:

Failure to follow these instructions can cause serious damage to your vehicle.

FRONT TOW:

Not recommended with conventional sling type equipment on the turbocharger model because the towing rope or chain will come into contact with the spoiler and damage may result.

- When towing your vehicle with the conventional sling type, be careful not to bring the rope, chain, etc. into contact with the vehicle body.
- Before towing, make sure that the transmission, axles, steering system and power train are in good order. If any unit is damaged a dolly must be used.
- Release the parking brake and set the gearshift lever in "Neutral" position before starting to tow the vehicle.
- The ignition key must remain in the "OFF" position to prevent the steering mechanism from locking.

TOWING WITH FRONT WHEELS RAISED OR ON ALL FOUR WHEELS

When towing an automatic transmission model, try to restrict towing speed to below 20 MPH (30 km/h) and towing distance less than 20 miles (30 km).

With manual transmission model, try to restrict towing speed to below 50 MPH (80 km/h) and towing distance less than 50 miles (80 km).

If the speed or distance must necessarily be greater, remove the propeller shaft beforehand to prevent damage to the transmission.

TOWING WITH REAR WHEELS RAISED

With the ignition switch in the "OFF" position, secure the steering wheel in a straight-ahead position with a rope or other similar device. Do not place ignition switch in the "LOCK" position. This will result in damage to the lock mechanism. If the steering wheel cannot be fixed securely, a dolly must be used.

TOWING HOOKS

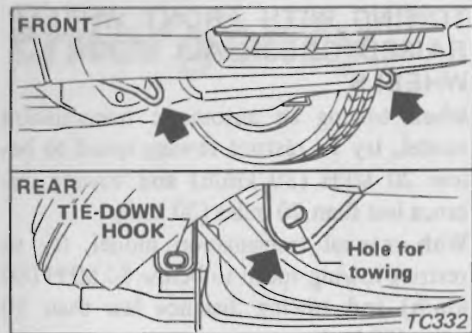

PUSH STARTING

No models should be pushed or pulled to start, since the catalytic converter may be damaged. Vehicles equipped with automatic transmissions cannot be started by pushing. Attempting to do so may damage the transmission or other components.

The towing hooks should be used only in emergency situations, e.g., to pull vehicle out of a ditch, a snow bank or mud. Always pull the cable in a straight direction with respect to the hook. Do not apply force to the hook in a side direction. To prevent damage, do not take up slack in the cable too quickly.

JUMP STARTING WITH BOOSTER BATTERY

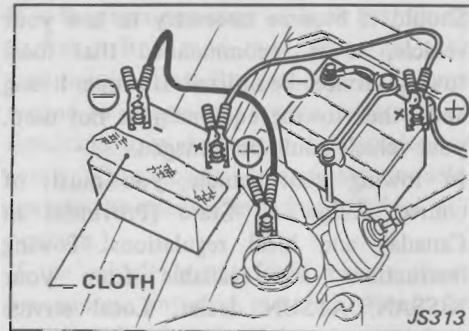

- If done incorrectly, jump starting can be hazardous.
- Because explosive hydrogen gas is always present in the vicinity of the battery, keep all sparks and flames away from it. Whenever charging or using a battery in a closed environment always be sure that there is suitable ventilation.
- The final booster cable connection must be to ground on the part shown in the illustration away from the battery to reduce the chance of an explosion set off by sparks.
- Do not, under any circumstances, allow battery fluid to come into contact with eyes, skin, cloth or painted surfaces. Battery fluid is a corrosive sulphuric acid solution which can cause severe

burns. If the fluid should come into contact with anything, immediately flush the contacted area with water.

- Whenever working on or near a battery, always wear suitable eye protectors (e.g., goggles or industrial safety spectacles) and remove rings, metal bands, or any other metal jewelry.
- Keep battery out of the reach of children.
- Always follow the instructions below exactly.

1. Position the two vehicles to bring their batteries into close proximity to each other. Set parking brakes. Set the shift lever in "Neutral" (On automatic transmission models set the lever in "P" position). Switch off all unnecessary electrical systems (light, heater, fan, etc.).

CAUTION:

- The booster battery voltage must not exceed 12 volts, or electric components and the control unit of the fuel injection system will be damaged.
- If the battery cables have been disconnected they should be tightly clamped to the battery terminals to secure a good contact.
- Do not allow the two vehicles to touch.

AMH00675

2. To reduce the explosion hazard inherent in connecting a live booster battery to a discharged battery, remove the vent caps (if so equipped) from both batteries and place a cloth over their open vent wells or open vent holes.
3. Run one jumper cable from the positive terminal (identified by "+" on the battery case, post, or clamp) of the booster battery to the positive terminal of the discharged battery.
4. Connect the other cable to the booster battery's negative terminal and to the engine lift bracket of the vehicle with the discharged battery [not to negative (-) terminal of battery].

CAUTION:

- Do not connect the positive lead to the negative terminal or vice versa. Doing so could cause damage to both charging systems or could even result in serious personal injury.
 - Make sure cables are clear of moving parts and that neither clamp contacts any other metal.
5. Start the engine of the other vehicle. After letting it run for a few minutes, start your engine in the normal manner.

6. Once you have your engine running carefully disconnect the jumper cables, exactly reversing the connection procedure.
7. Replace the vent caps if so equipped. Because the cloths used to cover the vent wells or holes may have been contaminated with corrosive acid, be sure to dispose of them in a safe manner.



IF YOUR VEHICLE OVERHEATS

Pull the vehicle safely off the road, put the transmission in "Neutral" (automatic transmission in "P" position) and lift the engine hood. If the air conditioning is on, turn it off. Do not stop the engine.

Visually check belts for damage or looseness. Also check the cooling fan for proper operation, and the radiator hoses and radiator for leakage.

WARNING:

- Be careful not to allow your hands or clothing to come into contact with, or to get caught in, the running fan or belts.
- The turbocharged engine model is equipped with an auxiliary fan in the engine compartment. The fan may come on as the ignition key is turned off when the coolant temperature is high. The fan may stay on for about 15 minutes after the ignition key is turned off.

If engine overheating is not caused by a faulty cooling system but by something else, such as climbing a long hill on a hot day, abrupt reduction of vehicle speed after high-speed driving or repeated stop-and-go driving in congested areas, the engine coolant temperature will start to drop

after the engine has run at idle for one or two minutes.

If coolant is leaking or the fan belt damaged or loose, stop the engine and have your vehicle brought to the nearest NISSAN/ DATSUN dealer or other competent service facility for repair.

To reduce the coolant temperature, run the engine for several minutes at a speed twice as high as the normal idle speed.

- After the engine cools down to normal operating temperature, again check for leakage and, with the engine running, add coolant as necessary. After starting the vehicle again, drive slowly for the first ten minutes, checking for any sign of abnormality. If no abnormality is noted during that time, resume normal driving.

WARNING:

To avoid the danger of being burned, never remove the radiator cap while the engine is still hot. When the radiator cap of a hot engine is removed, pressurized hot water will spurt out, possibly causing serious personal injury.

JUMP STARTING WITH BOOSTER BATTERY

Always follow the instructions below exactly.
Position the two vehicles to bring their batteries into close proximity to each other. Set parking brakes. Set the shift lever in "Neutral". On automatic transmission models set the lever in "P" position. Switch off all unnecessary electrical systems (light, heater fan, etc.).

- The booster battery cables should not exceed 12 volts or electric components and the control console. The fuel injection system will be damaged if the booster battery cables have been disconnected. They should be firmly clamped to the battery terminals to ensure a good contact. Do not allow the two vehicles to touch.



Emission Control Systems

The emission control system consists of (1) a crankcase emission control system, (2) an exhaust emission control system, and (3) an evaporative emission control system.

Under the laws of some jurisdictions, the owner may be subject to penalties for modification of the emission control system after delivery.

CRANKCASE EMISSION CONTROL SYSTEM

This system serves to prevent the emission of blow-by gases into the atmosphere.

EXHAUST EMISSION CONTROL SYSTEM

Models not equipped with turbocharger;

Electronic Fuel Injection (E.F.I.)
Exhaust Gas Recirculation (E.G.R.)
Three-way Catalyst (T.W.C.)
Closed Loop (C.L.)
Electronic Concentrated engine Control System (E.C.C.S.)

Models equipped with turbocharger;

Electronic Fuel Injection (E.F.I.)
Exhaust Gas Recirculation (E.G.R.)
Three-way Catalyst (T.W.C.)
Closed Loop (C.L.)
Electronic Concentrated engine Control System (E.C.C.S.)
Turbocharger (T.C.)

ELECTRONIC FUEL INJECTION (E.F.I.) SYSTEM

The electronic fuel injection system monitors the operating conditions of the engine through various types of sensors.

THREE-WAY CATALYTIC CONVERTER (T.W.C.)

The three-way catalytic converter is located midway along the exhaust tube.

This converter oxidizes hydrocarbons (HC) and carbon monoxide (CO) and at the same time reduces nitrogen oxides (NOx), thus minimizing these emissions.

EXHAUST GAS RECIRCULATION (E.G.R.) SYSTEM

This system controls the engine combustion temperature, thus reducing NOx emission.

CLOSED LOOP (C.L.) SYSTEM

The closed-loop system is designed to maintain the air/fuel ratio at a point that allows the three-way catalyst to simultaneously minimize CO, HC, and NOx emissions.

ELECTRONIC CONCENTRATED ENGINE CONTROL SYSTEM (E.C.C.S.)

This system monitors the operating conditions of the engine and vehicle through various types of sensors, and controls Fuel Injection, Idle Speed, Ignition timing, E.G.R. and Fuel Pump operation to obtain better driveability, fuel economy, etc.

TURBOCHARGER (T.C.)

This unit is installed as a part of the Air Flow System and sends the air which is pressurized by the turbine to the engine in order to increase power.

EVAPORATIVE EMISSION CONTROL SYSTEM

The evaporative emission control system prevents evaporative gases in the fuel tank from entering the atmosphere.

EMISSION CONTROL SYSTEM WARRANTY

Your NISSAN is covered by the following emission warranties.

For U.S.A.

- 1) Emissions Defects Warranty
- 2) Emissions Performance Warranty

For Canada

Emission Control System Warranty

Details of these warranties may be found with other vehicle warranties in your warranty booklet which comes with your NISSAN. If you did not receive a warranty booklet or it becomes lost, you may obtain a replacement by writing.

- Nissan Motor Corporation in U.S.A.
Consumer Relations Department
P.O. Box 191
Gardena, CA 90247
- Nissan Automobile Company
(Canada) Ltd.,
P.O. Box 2600,
Streetsville Postal Station,
Mississauga, Ontario,
L5M 2L5



Maintenance Schedule

In order to maintain your new NISSAN's good mechanical condition as well as its emission and engine performance, it is essential to have it (checked and) serviced by your NISSAN/DATSUN dealer or other competent service facility in accordance with the following Maintenance Schedule.

If maintenance service is required, or if your vehicle exhibits malfunctions, have the systems checked and tuned by an authorized NISSAN/DATSUN dealer or any other qualified service outlet.

PERIODIC MAINTENANCE

The following charts show the normal maintenance schedule. **Under severe driving conditions**, additional or more frequent maintenance will be required. Refer to "Maintenance under severe driving conditions".

The periodic maintenance schedule is repeated beyond the last mileage and period shown.



EMISSION CONTROL SYSTEM MAINTENANCE

MAINTENANCE OPERATION		MAINTENANCE INTERVAL			
Periodic maintenance should be performed at number of miles, kilometers or months, whichever comes first.	Miles x 1,000	15	30	45	60
	(Kilometers x 1,000)	(24)	(48)	(72)	(96)
	Months	12	24	36	48
Drive belts		I		I	
Air cleaner filter		R		R	
Vapor lines		I*		I*	
Fuel lines (hoses, piping, connections, etc.)		I*		I*	
Fuel filter		See NOTE (1)*			
Engine coolant		R		R	
Engine oil	Except turbocharged engine	Replace every 7,500 miles (12,000 km) or 6 months.			
	Turbocharged engine	Replace every 5,000 miles (8,000 km) or 6 months.			
Engine oil filter		Replace at the first oil change and then every second oil change.			
Spark plugs		R		R	
Ignition wires		I*		I*	
Idle rpm (Except turbocharged engine)		I*	I*	I*	I*
Exhaust gas sensor		I		I	

NOTE:

- (1) If vehicle is operated under extremely adverse weather conditions or in areas where ambient temperatures are either extremely low or extremely high, the filters might become clogged. In such an event, replace them immediately.
- (2) Maintenance items and intervals with "*" are recommended by NISSAN MOTOR CO., LTD. Other maintenance items and intervals are required.

Abbreviations: A = Adjust
 R = Replace
 I = Inspect. Correct or replace if necessary.

CHASSIS AND BODY MAINTENANCE

MAINTENANCE OPERATION	MAINTENANCE INTERVAL	MAINTENANCE INTERVAL			
		Miles x 1,000	30	45	60
Periodic maintenance should be performed at number of miles, kilometers or months, whichever comes first.	Miles x 1,000	15	30	45	60
	(Kilometers x 1,000)	(24)	(48)	(72)	(96)
	Months	12	24	36	48
Brake lines & hoses		I	I	I	I
Brake pads & discs		I	I	I	I
Brake fluid			R		R
Manual and automatic transmission & differential gear oil		I	I	I	I
Power steering lines & hoses		I	I	I	I
Steering gear & linkage, & suspension parts		I	I	I	I
Steering linkage ball joints & front suspension ball joints					I
Propeller shaft(s)			I		I
Locks, hinges & hood latch		L	L	L	L
Front wheel bearing grease			I		I
Exhaust system		I	I	I	I
Seat belts, buckles, retractors, anchors & adjuster		I	I	I	I

Abbreviations: L = Lubricate
R = Replace
I = Inspect, Correct or replace if necessary



MAINTENANCE UNDER SEVERE DRIVING CONDITIONS

The maintenance intervals shown on the preceding pages are for normal operating conditions. If the vehicle is operated under severe driving conditions as shown below, more frequent maintenance must be performed on the following items as shown in the table.

Severe driving conditions

- A – Repeated short distance driving
- B – Extensive idling
- C – Driving in dusty conditions
- D – Driving in extremely low or high ambient temperatures
- E – Towing a trailer
- F – Driving in areas using road salt or other corrosive materials
- G – Driving on rough and/or muddy roads
- H – Driving in high humidity areas or in mountainous areas

Driving condition	Maintenance item	Maintenance operation	Maintenance interval
. . . C	Air cleaner filter	R	More frequently
A B C . . E	Engine oil (Except turbo-charged engine)	R	Every 3,000 miles (5,000 km) or 3 months
	Engine oil (Turbocharged engine)	R	Every 2,500 miles (4,000 km) or 3 months
A B C . . E	Engine oil filter	R	At the first oil change and then every second oil change.
A . . C . . E F G . . .	Brake pads & discs	I	Every 7,500 miles (12,000 km) or 6 months
. H	Brake fluid	R	Every 15,000 miles (24,000 km) or 12 months
. E . . G	Manual and automatic transmission & differential gear oil)	R	Every 30,000 miles (48,000 km) or 24 months
. G	Steering gear & linkage, & suspension parts	I	Every 7,500 miles (12,000 km) or 6 months
. . . C D . . F G	Steering linkage ball joints & front suspension ball joints	I	Every 7,500 miles (12,000 km) or 6 months
. F	Locks, hinges & hood latch	I	Every 7,500 miles (12,000 km) or 6 months
A E F G	Exhaust system	I	Every 7,500 miles (12,000 km) or 6 months

Maintenance operations: I = Inspect. Correct or replace if necessary R = Replace

EXPLANATION OF MAINTENANCE ITEMS

Additional information on the following items with "*" is found in the "Do-It-Yourself" section.

Emission control system maintenance

Drive belts* Check drive belts for wear, fraying or cracking and also for proper tension. Replace the drive belts if found damaged.

Air cleaner filter Under normal driving conditions, the air cleaner filter should be replaced in accordance with the maintenance schedule. However, driving the vehicle in dusty areas may cause more rapid clogging of the element. Consequently, the element may have to be replaced more frequently.

Vapor lines Check vapor lines and connections for failure or looseness. If leaks are found, replace them.

Fuel lines (hoses, piping, connections, etc.) Check the fuel hoses, piping and connections for leaks, looseness or deterioration. Replace any parts if they are damaged.

Fuel filter If the vehicle is operated under extremely adverse weather conditions or in areas where ambient temperatures are either extremely low or extremely high, the filter might become clogged. In such an event, replace the filter immediately.

Engine coolant* Drain and flush the cooling system.

Engine oil & oil filter* Under normal driving conditions, the engine oil and oil filter should be replaced in accordance with the maintenance schedule. However, under severe driving conditions, they may have to be replaced more frequently.

Spark plugs* Replace with new plugs having the correct heat range.

Ignition wires Check the ignition wires for cracking of exterior insulation and for proper fit on the distributor cap and spark plugs.

Idle rpm (Except turbocharged engine) Inspection and adjustment should be made with a tachometer to ensure accuracy.

Exhaust gas sensor Check the exhaust gas sensor for proper operation.

Chassis and body maintenance

Brake lines & hoses Check the brake lines and hoses (including brake booster vacuum hoses, connections & check valve) for proper attachment, leaks, cracks, chafing, abrasion, deterioration, etc.

Brake pads & discs Check these and the other neighboring brake components for wear, deterioration and leaks. Under severe driving conditions, they may have to be inspected more frequently.

Brake fluid Under normal driving conditions, the brake fluid should be replaced in accordance with the maintenance schedule. However when driving in high humidity areas or in mountainous areas, the interval should be shortened.

Manual and automatic transmission* & differential gear oil Visually inspect for signs of leakage. Under severe driving conditions, the oil should be replaced at the specified interval.

Power steering lines & hoses Check the lines & hoses for proper attachment, leaks, cracks, chafing, abrasion, deterioration, etc.

Steering gear & linkage, & suspension parts Check for damage, looseness and leakage of oil or grease. Under severe driving conditions, more frequent inspection should be performed.

Steering linkage ball joints & front suspension ball joints Check the ball joints for damage, looseness and grease leakage. Under severe driving conditions, more frequent inspection should be performed.

Propeller shaft Check the propeller shaft for damage, looseness and grease leakage.

Locks, hinges & hood latch* Lubricate all locks and hinges on all doors including trunk lid, back hatch and hood latch. When driving in areas using road salt or other corrosive materials, inspection should be performed more frequently.

Front wheel bearing grease Check for grease leakage around grease seals, axial end play and smooth turning.

Exhaust system Visually check the exhaust pipes, muffler, and hangers for proper attachment, leaks, cracks, chafing, abrasion, deterioration, etc. Under severe driving conditions, inspection should be performed more frequently.

Seat belts, buckles, retractors, anchors & adjuster Check for damage, deterioration, proper functioning, smooth operation and loose mounting.

GENERAL MAINTENANCE

General maintenance includes those items which should be checked during the normal day-to-day operation of the vehicle. They are essential if your vehicle is to continue operating properly. It is your responsibility to perform these procedures regularly as prescribed. As the driver, you are the only one who can ensure that your vehicle receives the proper maintenance care. Remember, you are a vital link in the maintenance chain. You can perform the checks and inspections yourself or you can have your NISSAN/ DATSUN dealer do them for a nominal charge. If you detect any unusual sounds, vibrations or smell, be sure to check for the cause or have your NISSAN/DATSUN dealer or other competent service facility do it promptly. In addition, you should notify your NISSAN/DATSUN dealer or other competent service facility if you think that repairs are required.

When performing any checks or maintenance work, closely observe the precautions in the "Do-It-Yourself" section.

Additional information on the following items with "*" is found in the "Do-It-Yourself" section.

OUTSIDE THE VEHICLE

Tires* Check the pressure with a gauge periodically when at a service station, and adjust to the specified pressure if necessary. Check carefully for damage, cuts or excessive wear.

Wheel nuts* When checking the tires, make sure no nuts are missing, and check for any loose nuts. Tighten if necessary.

Tire rotation* Tires should be rotated every 15,000 miles (24,000 km).

Wheel alignment and balance If the vehicle should pull to either side while driving on a straight and level road, or if you detect uneven or abnormal tire wear, there may be a need for wheel alignment. If the steering wheel or seat vibrates at normal highway speeds, wheel balancing may be needed.

Windshield glass Check for abrasions or scratches.

Windshield wiper blades* Check for cracks or wear if they do not wipe properly.

Doors and engine hood* Check that all doors and the engine hood operate smoothly as well as the trunk lid and back hatch.

Also ensure that all latches lock securely. Lubricate if necessary. Make sure that the secondary latch keeps the hood from opening when the primary latch is released.

INSIDE THE VEHICLE

The maintenance items listed here should be checked on a regular basis, such as when performing periodic maintenance, cleaning the vehicle, etc.

Lights* Make sure that the headlights, stop lights, tail lights, turn signal lights, and other lights are all operating properly and installed securely. Also check headlight aim.

Warning lights and chimes Make sure that all warning lights and chimes are operating properly.

Horn Make sure it operates properly.

Windshield wiper and washer* Check that the wipers and washer operate properly and that the wipers do not streak.

Windshield defroster Check that the air comes out of the defroster outlets properly and in sufficient quantity when operating the heater or air conditioner.

Rear view mirror Make sure that it is secure.

Sun visors Make sure that they can be moved freely and are secure.

Steering wheel* Check that it has the specified freeplay. Be sure to check for changes in the steering condition, such as excessive freeplay, hard steering or strange noises.

Seats Check front seat position controls such as seat adjusters, seatback recliner, etc. to ensure they operate smoothly and that all latches lock securely in every position. Check that the head restraints move up and down smoothly and that the locks (if so equipped) hold securely in all latched positions. Check that the latches lock securely for folding-down rear seatbacks.

Seat belts Check that all parts of the seat belt system e.g. buckles, anchors and retractors operate properly and smoothly. Check the belt webbing for cuts, fraying, wear or damage.

Accelerator pedal Check the pedal for smooth operation and make sure the pedal does not catch or require uneven effort.

Clutch pedal* Make sure the pedal operates smoothly and check that it has the proper free travel.

Brakes Check that the brake does not pull the vehicle to one side when applied.

Brake pedal* Check the pedal for smooth operation and make sure it has the proper distance under it when depressed fully. Check the brake booster function.

Parking brake* Check that the lever has the proper travel and confirm that your vehicle is held securely on a fairly steep hill with only the parking brake applied.

Automatic transmission "Park" mechanism Check that the lock release button on the selector lever operates properly and smoothly. On a fairly steep hill check that your vehicle is held securely with the selector lever in the "P" position without applying any brakes.

UNDER THE HOOD AND VEHICLE

The maintenance items listed here should be checked periodically e.g. each time you check the engine oil or refuel.

Windshield washer fluid* Check that there is adequate fluid in the tank.

Engine coolant level* Check the coolant level when the engine is cold.

Radiator and hoses Check the front of the radiator and clean off any dirt, insects, leaves, etc., that may have accumulated. Make sure the hoses have no cracks, deformation, rot or loose connections.

Brake and clutch fluid levels* Make sure that the brake and clutch fluid levels are between the "MAX" and "MIN" lines on the reservoir.

Engine drive belts* Make sure that no belt is frayed, worn, cracked or oily.

Engine oil level* Check the level on the dipstick after parking the vehicle on a level spot and turning off the engine.

Power steering fluid level* Check the level on the dipstick when the fluid is cold and the engine is turned off.

Automatic transmission fluid level* Check the level on the dipstick after putting the selector lever in "P" with the engine idling.

Exhaust system Make sure there are no loose supports, cracks or holes. If the sound of the exhaust seems unusual or there is a smell of exhaust fumes, imme-

diately locate the trouble and correct it. (Refer to the carbon monoxide warning in the "Starting and Operation" section)

Underbody The underbody is frequently exposed to corrosive substances such as those used on icy roads or to control dust. It is very important to remove these substances, otherwise rust will form on the floor pan, frame, fuel lines and around the exhaust system. At the end of winter, the underbody should be thoroughly flushed with plain water, being careful to clean those areas where mud and dirt can easily accumulate. Refer to the "Appearance and Interior Care" section for additional information.

Fluid leaks Check under the vehicle for fuel, oil, water or other fluid leaks after the vehicle has been parked for a while. Water dripping from the air conditioner after use is normal. If you should notice any leaks or gasoline fumes are evident, check for the cause and correct it immediately.



Do-It-Yourself

PRECAUTIONS

When performing any inspection or maintenance work on your vehicle, always exercise care to prevent accidental personal injury to yourself or damage to the vehicle. The following are general precautions which should be closely observed in carrying out any servicing operation.

- Set the parking brake securely.
- Do not work on the engine while it is hot. Always turn it off and allow it to cool down.
- If you must work with the engine running, remove necktie and any jewelry, such as rings, watch, etc. Keep your hand, clothing, hair and tools away from moving fans and fan belts.
- The turbocharged engine model is equipped with an auxiliary fan in the engine compartment. The fan may come on as the ignition key is turned off when the coolant temperature is high. The fan may stay on for about 15 minutes after the ignition key is turned off.
- Never get under the vehicle while it is supported by a jack. If it is necessary to work under the vehicle, use safety stands.

- Keep smoking materials, flame or sparks away from gasoline or battery.
- Never connect or disconnect either the battery or any transistorized component while the ignition key is on.
- When connecting the battery cables, pay particular attention to their polarities. Never confuse the positive cable with the negative cable.
- When performing any checks with the engine running in an enclosed space such as a garage, be sure there is proper ventilation.

This "Do-It-Yourself" section gives instructions regarding only those items which are relatively easy for an owner to perform.

The "Periodic Maintenance and Lubrication Schedule" is included in this booklet. However, sustained heavy duty or high speed operations or operation under adverse conditions may necessitate more frequent servicing. You should be aware that incomplete or improper servicing may result in operating difficulties or excessive emissions, and could affect your warranty coverage. If in doubt about any servicing, have it done by an authorized NISSAN/DATSUN dealer or other competent service facility.

Before changing oil, check for a suitable way to dispose of the old oil. Do not pour it down sewage drains, onto garden soil, or into open streams. Your zoning or environmental regulations will give you more detailed instructions on such disposal. We suggest that you have your oil changed at your authorized NISSAN/DATSUN dealer or other competent service facility.

OIL AND FUEL RECOMMENDATION

FUEL RECOMMENDATION

All models are designed to operate on unleaded gasoline with an octane rating of at least 87 AKI (Anti-Knock Index) number (91 Research octane number).

Using a fuel other than that specified could adversely affect the emission control devices and systems, resulting in loss of coverage under the emission control warranty. It may also affect coverage under other NISSAN warranties.

Under no circumstances should a leaded gasoline be used since this will damage the catalytic converter.

In most parts of North America, you should use unleaded gasoline with an octane rating of at least 87 AKI (Anti-Knock Index) number. However, you may use unleaded gasoline with an octane rating as low as 85 AKI (Anti-Knock Index) number in these high altitude areas [over 4,000 ft (1,219 m)] such as: Colorado, Montana, New Mexico, Utah, Wyoming, northeastern Nevada, southern Idaho, western South Dakota, and that part of Texas which is directly south of New Mexico.

Using unleaded gasoline with an octane rating lower than stated above can cause

persistent, heavy "spark knock." ("Spark knock" is a metallic rapping noise.) If severe, this can lead to engine damage. If you detect heavy spark knock even when using gasoline of the stated octane rating, or if you hear steady spark knock while holding a steady speed on level roads, have your dealer correct the problem. Failure to take steps to stop such knocking is misuse of the car, for which NISSAN/DATSUN is not responsible.

Incorrect ignition timing, or the use of a fuel whose octane rating is too low, will result in knocking, after-run or overheating. This in turn may cause excessive fuel consumption or damage to the engine. If any of the above symptoms are encountered, have your vehicle checked at a NISSAN/DATSUN dealer or other competent service facility.

However, now and then you may notice light spark knock for a short time while accelerating or driving up hills. This is no cause for concern, because you get the greatest fuel economy benefit from the gasoline's octane rating when there is occasional light spark knock. Using gasoline with a higher octane rating than that which allows occasional spark knock is an unnecessary expense.

ENGINE OIL AND OIL FILTER RECOMMENDATION

Selecting the correct oil

There are three oil characteristics which must be considered when selecting the correct engine oil. They are quality, viscosity and frictional characteristics. It is essential that the correct quality and viscosity oil is chosen to ensure satisfactory life and performance of the engine. It is further recommended on the non-turbo engine that a low friction oil (energy conserving oil) be selected in order to improve fuel economy and conserve energy. **Oil which may contain foreign matter or has been previously used should not be used.**

OIL QUALITY

The quality of the engine oil is shown on the container in accordance with API (American Petroleum Institute) designations of quality.

Oils which do not have the specified quality label should not be used as they could cause engine damage.

Non-turbo engine oil: Only energy conserving oils with the designation "SF" should be used. The oil may be labeled with a single designation "SF", or "SF" in combination with other categories, for example, "SF/CC".

Turbo engine oil: Use oils with the designation "SF/CC" or "SF/CD".

OIL VISCOSITY

The engine oil viscosity or thickness changes with temperature. Because of this it is important that the engine oil viscosity be selected based on the temperatures at which the vehicle will be operated before the next oil change. The following chart "Recommended SAE viscosity number" shows the recommended oil viscosities for the expected ambient temperatures. Choosing an oil viscosity other than that recommended could cause serious engine damage.

ENERGY CONSERVING OILS

In order to improve fuel economy and conserve energy new, lower friction engine oils have been developed. These oils are readily available and can be identified by such labels as energy conserving, energy saving, improved fuel economy, etc.

OIL IDENTIFICATION

A standard symbol may be used to help you select the correct oil. A typical symbol is shown below, the upper portion designates the quality, the center designates the viscosity and the lower section indicates that the oil has fuel saving capabilities.



Selecting the correct oil filter

Your new vehicle is equipped with a high-quality genuine NISSAN oil filter. When replacing, use the genuine oil filter Part No. 15208-H8917 or its equivalent for the reason described in "change intervals".



RECOMMENDED LUBRICANT SPECIFICATIONS

Change intervals

The oil and oil filter change intervals for your engine are based on the use of the specified quality oils and filters. Oil and filter other than the specified quality, or oil and filter change intervals longer than recommended could reduce engine life. Damage to engines caused by improper maintenance or use of incorrect oil and filter quality and/or viscosity is not covered by the new Nissan vehicle warranties.

Your engine was filled with a high quality engine oil when it was built. You do not have to change the oil before the first recommended change interval. Oil and filter change intervals depend upon how you use your vehicle. Operation under the following conditions may require more frequent oil and filter changes.

- repeated short distance driving at cold outside temperatures,
- driving in dusty conditions,
- extensive idling,
- towing a trailer.

Lubricant		Specifications	Remarks
Engine oil	Non-Turbo engine	API SF (Energy Conserving Oils)	For further details, refer to "Engine oil and oil filter recommendation".
	Turbo engine	API SF/CC or SF/CD*1	
Gear oil	Transmission except for Turbo model	API GL-4	For further details, refer to the recommended SAE viscosity chart.
	Transmission for Turbo model	API GL-4 (SAE 75W-90) or Type DEXRON	
	Differential	API GL-5	
Automatic-T/M and power steering fluid		Type DEXRON	-
Multi-purpose grease		NLGI No. 2	Lithium soap base
Brake and clutch fluid		DOT 3	US FMVSS No. 116
Anti-freeze		-	Ethylene glycol base

*1: On models equipped with a turbocharger, use 10W-30, 10W-40, 20W-20, 20W-40 or 20W-50 except under extremely cold conditions. Use 5W-30 only under extremely cold conditions.



RECOMMENDED SAE VISCOSITY NUMBER

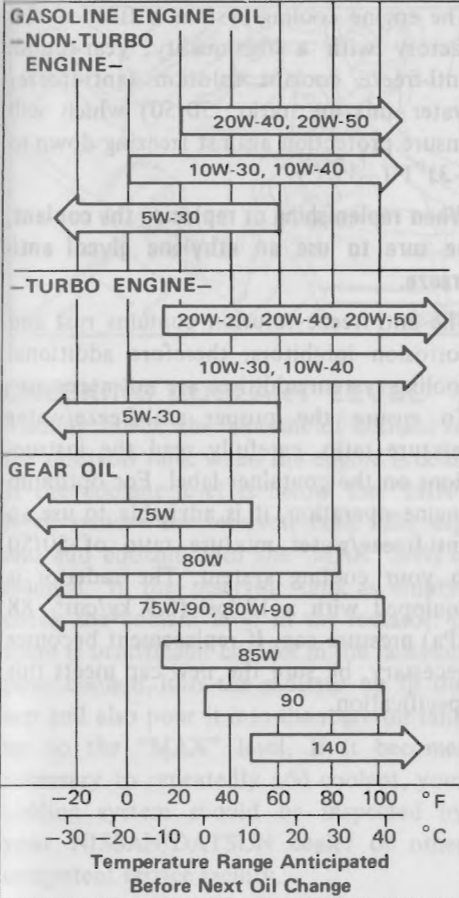

AMH00691

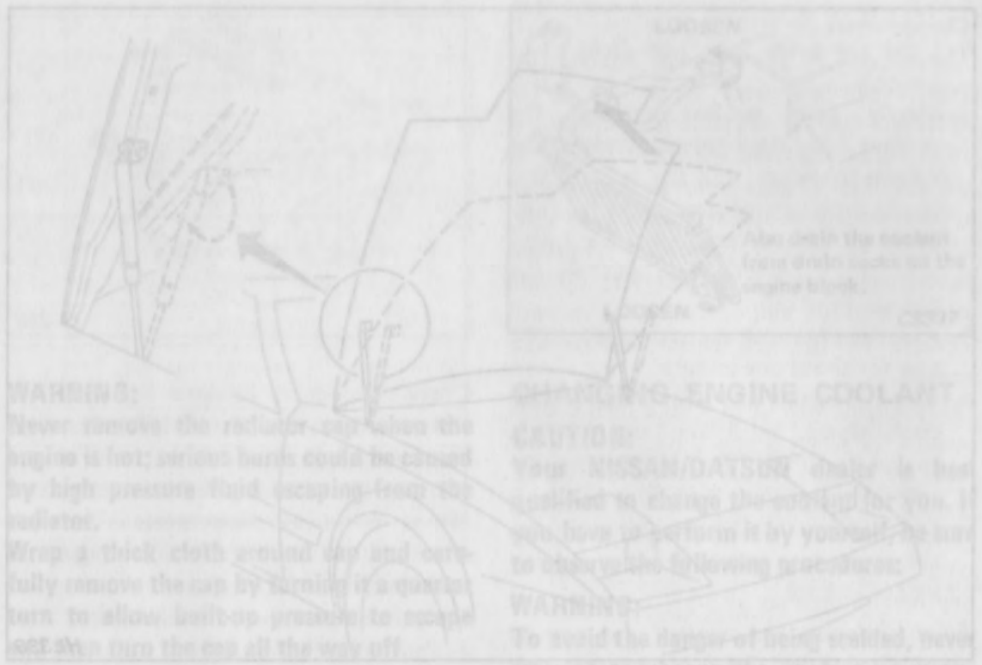

- For safety's sake, it is recommended that this operation be performed by two persons.
- Before closing the hood, be sure to reinstall the stay in the regular mounting hole. Failure to do so can damage the stay or hood.

WARNING:
Never remove the radiator cap when the engine is hot; serious burns could be caused by high pressure fluid escaping from the radiator.
Wrap a thick cloth around the cap and fully remove the cap by turning it clockwise to turn the cap all the way off.

CAUTION:
Your NISSAN/DATSUN dealer is best qualified to change the coolant for you. It may be necessary to bleed the system to ensure proper coolant flow.

WARNING:
To avoid the danger of injury, do not touch the engine or radiator until they are cool.

CAUTION:
The hood can be opened further than normal in order to better facilitate the maintenance of the engine. Open the hood, remove the bolts securing the stay to the hood, and install the stay in the lower hole provided. Do not allow the hood to swing out to view.

XENON
GHI-CHI

HOOD

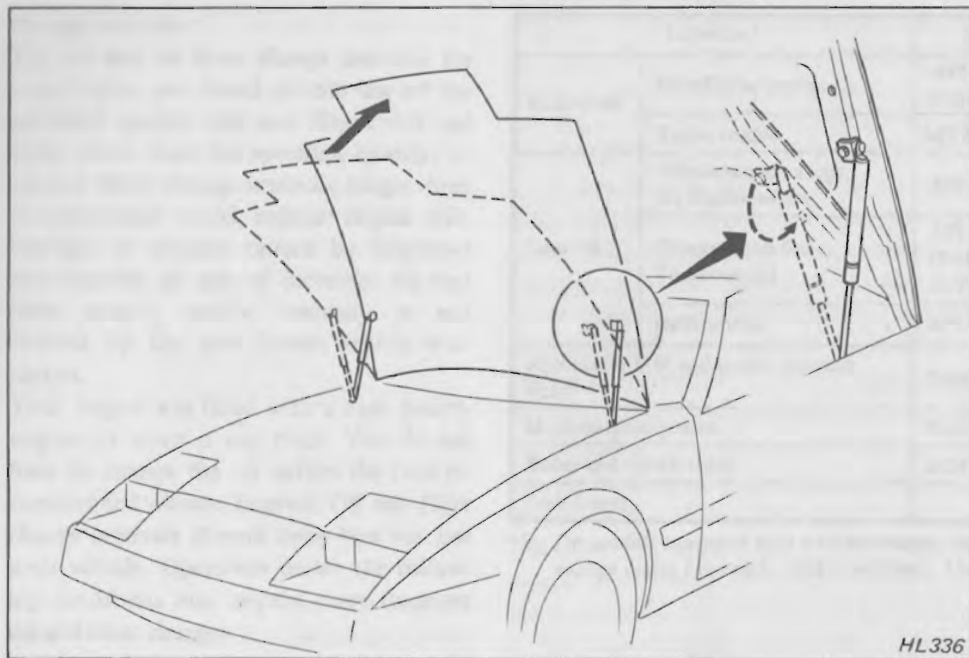

The hood can be opened further than normal in order to better facilitate the maintenance of the engine. Open the hood, remove the bolts securing the stay to the hood, and install the stay in the lower hole provided.

AMH00692

- For safety's sake, it is recommended that this operation be performed by two persons.
- Before closing the hood, be sure to reinstall the stay in the regular mounting hole. Failure to do so can damage the stay or hood.

ENGINE COOLING SYSTEM

The engine cooling system is filled at the factory with a high-quality, year-round, anti-freeze coolant solution (anti-freeze/water mixture ratio: 50/50) which will ensure protection against freezing down to -31°F (-35°C).

When replenishing or replacing the coolant, be sure to use an ethylene glycol anti-freeze.

The anti-freeze solution contains rust and corrosion inhibitors, therefore additional cooling system additives are not necessary. To ensure the proper anti-freeze/water mixture ratio, carefully read the instructions on the container label. For optimum engine operation, it is advisable to use an anti-freeze/water mixture ratio of 50/50 in your cooling system. The radiator is equipped with a 13 psi ($0,9\text{ kg/cm}^2$, 88 kPa) pressure cap. If replacement becomes necessary, be sure the new cap meets this specification.

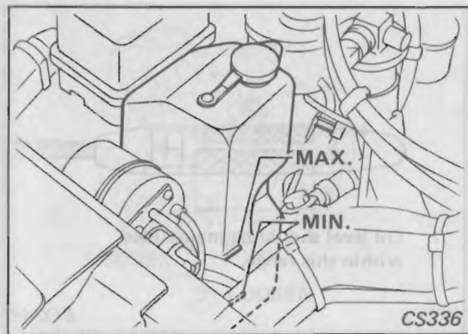

CHECKING COOLANT LEVEL

Visually check the amount of coolant in the reservoir tank when the engine is cold. If the coolant level is below the "MIN" level, remove the reservoir tank filler cap and add coolant until the "MAX" level is reached. If the reservoir tank is empty, check the coolant level in the radiator. If there is insufficient coolant in the radiator, pour coolant into the radiator up to the cap and also pour it into the reservoir tank up to the "MAX" level. If it becomes necessary to repeatedly add coolant, your cooling system should be inspected by your NISSAN/DATSUN dealer or other competent service facility.



WARNING:

Never remove the radiator cap when the engine is hot; serious burns could be caused by high pressure fluid escaping from the radiator.

Wrap a thick cloth around cap and carefully remove the cap by turning it a quarter turn to allow built-up pressure to escape and then turn the cap all the way off.

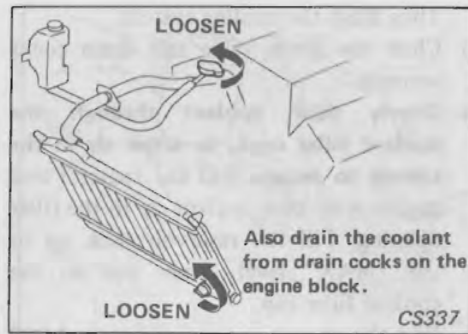

CHANGING ENGINE COOLANT

CAUTION:

Your NISSAN/DATSUN dealer is best qualified to change the coolant for you. If you have to perform it by yourself, be sure to observe the following procedures:

WARNING:

To avoid the danger of being scalded, never attempt to change the coolant when the engine is hot.

1. Move the temperature control lever of the heater or air conditioner control to the "HOT" position.
2. Open the coolant filler cap and drain valve of the radiator to drain the coolant. Open the drain cocks on the left and right sides of the engine block.

CHECKING ENGINE OIL LEVEL

ENGINE COOLING SYSTEM

Then flush the cooling system.

3. Close the drain valve and drain cocks securely.
4. **Slowly pour coolant through the coolant filler neck, to allow air in the system to escape.** Fill the radiator and engine with new coolant up to the filler opening. Fill the reservoir tank up to the "MAX" level. Then put on the coolant filler cap.
5. Run the engine at approximately 2,000 rpm for about one minute.
6. Stop the engine and after it completely cools down, refill the radiator and engine up to the filler opening. Fill the reservoir tank up to "MAX" level.
7. Put on the coolant filler cap and check the drain valve and drain cocks for any sign of leakage.

After replacing the coolant, be sure to check the coolant level of reservoir tank some time after the engine has cooled. Add coolant if necessary.

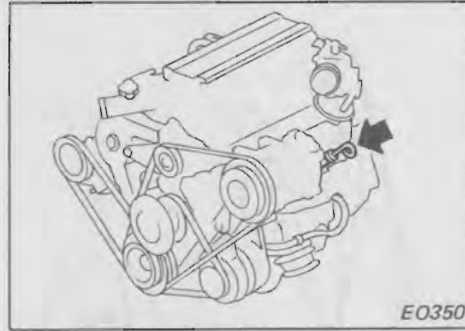

Check the engine oil level regularly and maintain it at the correct level. The best time to check the oil level is several minutes after the engine has been turned off at operating temperature. This will allow oil accumulated in the engine to drain back into the oil pan.

To make an accurate oil level check:

1. Park the vehicle on a level surface.
2. Turn off engine.
3. Remove the dipstick and wipe it clean.
4. Reinsert it all the way into the tube for an accurate reading.
5. Remove the dipstick and check the oil level. It should be between the "H" and "L" marks.
6. After taking the reading, reinsert the dipstick securely.

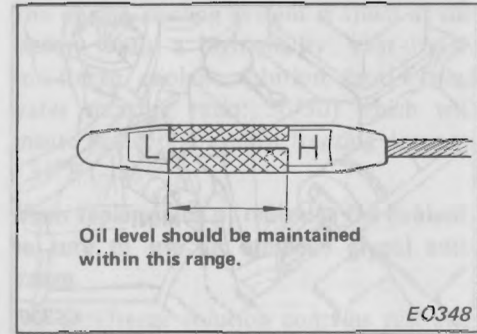

If the oil level is at or below the "L" mark, add sufficient oil into the oil filler, located on the right side rocker cover, to raise the level to the "H" mark. Do not overfill.

It is normal to add some oil between oil changes or during the break-in period, depending on the severity of operating conditions.

Oil level should be checked regularly. Operating with insufficient amount of oil can damage the engine.

CHANGING ENGINE OIL AND OIL FILTER

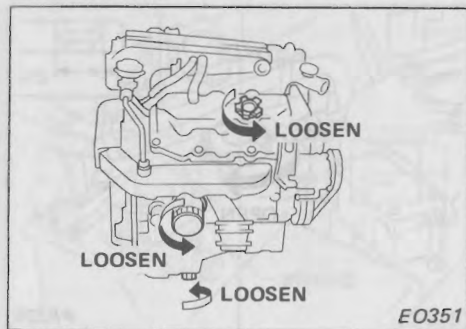

For the engine oil and oil filter, refer to the information described under the heading "Engine oil and oil filter recommendation".

The engine oil and oil filter should be replaced periodically.

1. Park the vehicle on a level surface and set the parking brake.
2. Warm up the engine until it reaches operating temperature, and then turn it off.
3. Place a drain pan under the drain plug of the oil pan.
4. Remove the oil filler cap.
5. Remove the drain plug with a wrench and completely drain the oil.

Be careful not to burn yourself, as the engine oil may be hot.

AMH00695

6. Clean and re-install the drain plug with washer. Tighten the plug with a wrench, but do not use excessive force.

It is recommended that the oil filter be replaced at the same time.

- a. Remove the oil filter. If the oil filter is hard to remove by hand, use an oil filter wrench.
- b. Wipe the engine oil filter mounting surface with a clean rag.
- c. Smear a little engine oil on the rubber gasket of the new filter.
- d. Screw in the oil filter until a slight resistance is felt, then tighten an additional 2/3 by hand.

Do not tighten with the oil filter wrench.

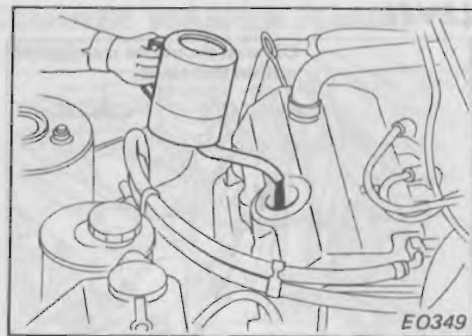

7. Refill oil and install the cap securely. Refer to "Capacity at oil change" in the "Gas Station Information".
8. Start the engine. Check the area around the drain plug and oil filter for any sign of oil leakage. If any leakage is evident, these parts have not been properly installed.
9. Run the engine until it reaches operating temperature. Then turn it off and wait several minutes. Check the oil level. If necessary, add engine oil.



CHECKING AUTOMATIC TRANSMISSION FLUID LEVEL



WARNING:

When engine is running, keep hands and clothing away from any moving parts such as fan and drive belt.

1. Drive the vehicle several miles (kilometers) to bring the transmission up to normal operating temperature. [Approximately 158°F (70°C)]
2. Park the vehicle on a level surface.
3. Set the parking brake.
4. Place the selector lever in the park "P" position and leave the engine running.
5. Remove the dipstick and wipe it clean.
6. Reinsert the dipstick all the way into the dipstick pipe.
7. Remove the dipstick and note reading.

AMH00696

CHECKING ZF POWER STEERING FLUID LEVEL

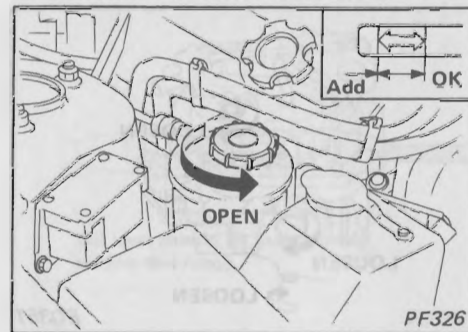

If the fluid level is at or below the "L" mark, add sufficient fluid through the dipstick pipe to raise the level to the "H" mark. Do not overfill above "H" mark. See the "Recommended Lubricants" for fluid.

With engine off, check the fluid level in reservoir by observing the dipstick when the fluid is cold. Add fluid as necessary to bring the level into proper range on dipstick.

CHECKING BRAKE AND CLUTCH FLUID LEVELS

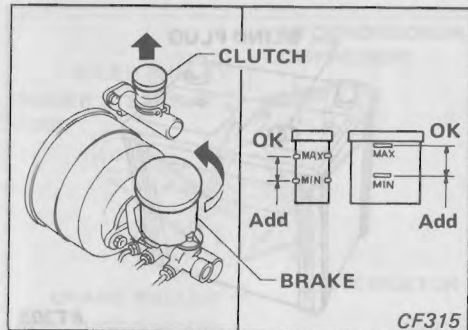

Check the fluid level in each reservoir. It should be between the Max. and Min. lines on the reservoir. If it is below the Min. line or the brake warning light comes on, add brake fluid DOT 3 up to the Max. line.

Use only new brake fluid. Use of an old or inferior brake fluid may endanger the functioning of the brake and clutch systems.

- Do not allow the brake fluid to come into contact with painted surfaces. This may damage the paint.
- Before opening the reservoir cap, wipe it clean with a rag.

If brake fluid must be added frequently, the system should be thoroughly checked by your NISSAN/DATSUN dealer or other competent service facility.

AMH00697

CHECKING WINDSHIELD/REAR WINDOW/HEADLIGHT CLEANER WASHER FLUID LEVEL

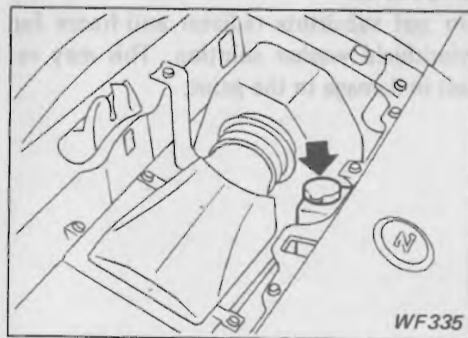
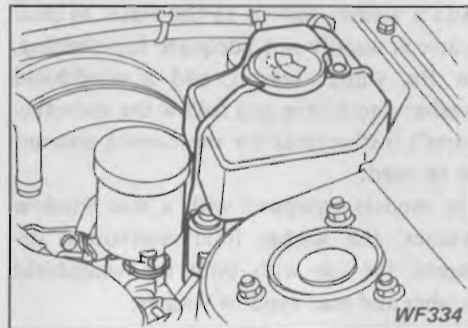

WARNING:

With service stations continuing to convert to self-service operations, many motorists check fluid levels in their vehicles themselves and add fluids when necessary. Adding the wrong type brake fluid or allowing the braking system to become contaminated can damage the system and affect the vehicle's stopping ability.

Check fluid level in the washer reservoir and add fluid if necessary.

Add a washer solvent to the water as clear water is usually not adequate for cleaning. In the winter season, add a windshield washer anti-freeze and follow the manufacturer's instructions for the correct amount to be used.

On models equipped with a rear window washer, the washer fluid reservoir is designed for use with both the windshield washer and rear window washer.

CAUTION:

Do not substitute radiator anti-freeze for windshield washer solution. This may result in damage to the paint.

CHECKING BATTERY FLUID LEVEL AND CONDITION

WARNING:

Do not expose the battery to flames or electrical sparks. Hydrogen gas generated by battery action is explosive. Do not allow battery fluid to come in contact with skin, eyes, fabrics, or painted surfaces. After touching a battery, or battery cap, do not touch or rub your eyes until you have thoroughly washed your hands. If the acid contacts the eyes, skin or clothing, immediately flush with water for 15 minutes and seek medical attention.

The battery surface should be clean and dry. Periodically apply a small amount of grease to each terminal to minimize corrosion.

This battery does not require periodic fluid level check or addition of distilled water.

If charging is necessary, run the engine to charge the battery. Should the engine fail to start, charge the battery for at least 4 hours using 6-ampere direct current flow, and again try to start the engine. If the engine still does not start, the battery has reached the end of its useful life and should be replaced.

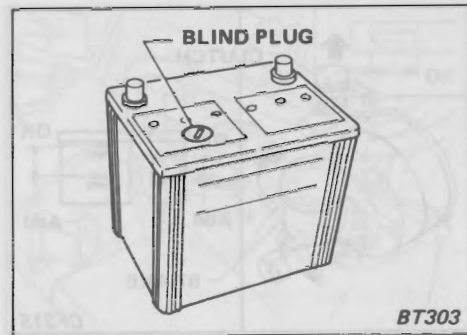

BT303

When the blind plug on the upper surface of the battery is removed, the electrolyte specific gravity can be measured.

CAUTION:

Do not use more than 10-ampere current flow to charge the battery quickly, as this will shorten the battery's service life.



CHECKING DRIVE BELTS

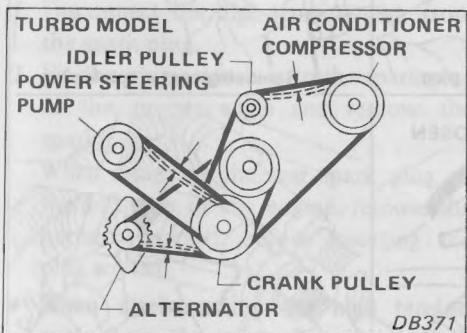
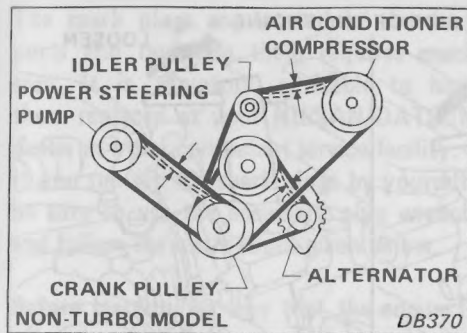

- The drive belts used in your vehicle do not usually require inspection because they are the automatically elastic type with exceptional durability. However, if the vehicle has been driven in severe conditions, it is recommended to check the belts by using the following procedure:
- Be sure the engine is off and the transmission is in "Neutral". Engage the parking brake securely.

1. Visually inspect each belt for signs of unusual wear, cuts or fraying. If a belt is in poor condition, have it replaced by your NISSAN/DATSUN dealer or other competent service facility.
2. Check the belt tension by applying 22 lb (98N) of pressure with your thumb midway between the pulleys. The belt should deflect within the specified amount as shown in the specification section. If the belt tension is not proper, have it adjusted by your NISSAN/DATSUN dealer or other competent service facility.

REPLACING SPARK PLUG

CHECKING DRIVE BELTS

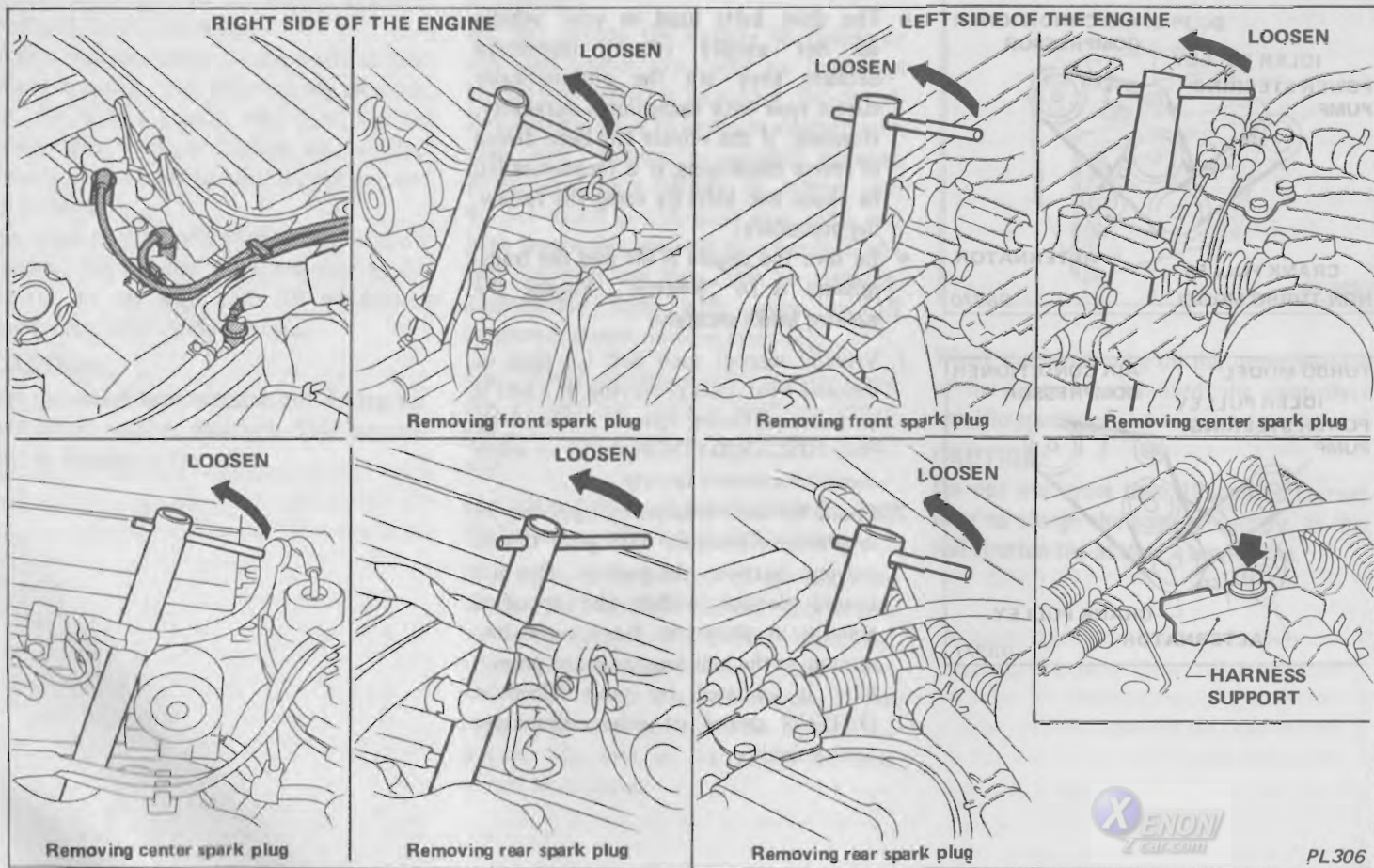

AMH00700



PL306

The spark plugs are located in the deep ports and replacing them requires much care. It is, therefore, advisable to have them replaced at your NISSAN/DATSUN dealer or other competent service facility. If you replace the spark plugs by yourself, be sure to use the accessory plug wrench and follow the instructions given below.

Before starting, be sure that the engine is off and parking brake engaged securely.

1. Disconnect the high tension cable from the spark plug.
2. Fit the plug wrench onto the spark plug at the proper angle and remove the spark plug.
When removing the rear spark plug on the left side of the engine, remove the harness support before inserting the plug wrench.
- **When disconnecting the high tension cable from the spark plug, always hold the boots, not the cables, to identify their original locations.**
- **The plug wrench has a rubber which holds the spark plug so that it will not fall off when it is pulled out. When pulling out the plug from the port, make sure that the spark plug is snugly fitted in the plug port.**

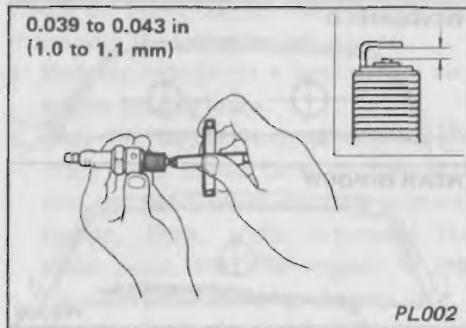

3. Before installing a new spark plug, check each spark plug gap with a feeler gauge to see if it is within the specified range. If it is not, bend the side electrode until the gap is within the specified range.
4. With a spark plug fitted tightly in the plug wrench, insert the plug into the port at the proper angle. It is important that the spark plug fit tightly or else it may fall from the plug wrench during replacement.
5. When installing a plug, screw and tighten it with a spark plug wrench to 14 to 22 ft-lb (20 to 29 N·m). Be careful not to overtighten it.

6. Holding the boots, re-connect the high tension cables to their proper locations until you feel a snap.

After the rear spark plug on the left side of the engine has been replaced, install the harness support to its original position.

CHECKING HOOD LOCK

 LUBRICATION POINT

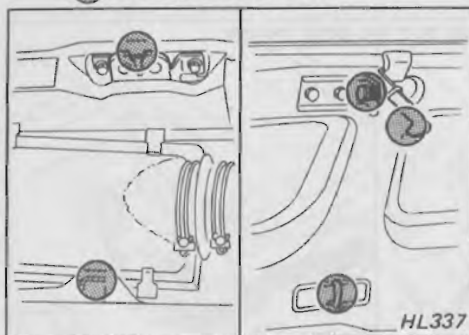

After closing the hood, always check to see if it is closed and latched securely.

Lubricate hood lock assembly periodically as recommended in the "Periodic Maintenance and Lubrication Schedule".

Coat all functioning parts with grease after wiping off any accumulation of dirt on lock parts.

Make certain that the lock and release mechanisms operate smoothly.

CHECKING WIPER BLADES/ WASHER NOZZLES

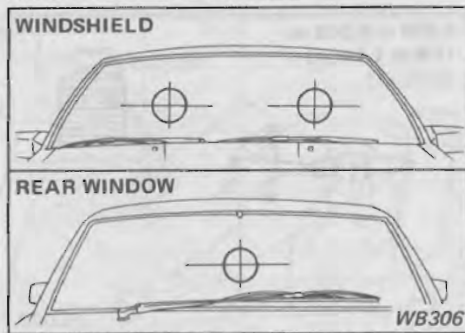

Check the wiper blades for operation and cleanliness. If the wiper blades do not wipe the windshield or rear window clean after the blades have been wiped with a cloth, replace the blades.

To adjust the washer spray, move the nozzles toward the center of each half of the windshield and toward the center of the rear window.

CHECKING PARKING BRAKE CONDITION

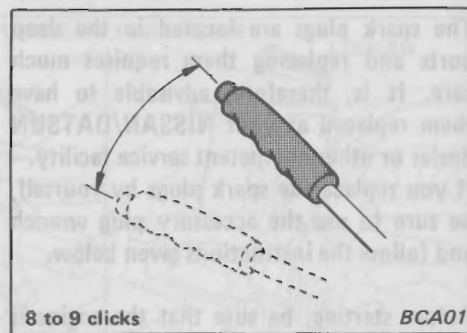

From the completely released position, apply the parking brake slowly and firmly, counting the clicks. If the number of clicks is as shown in the illustration, the parking brake is in good condition. If the number is out of the range, have the parking brake adjusted by your authorized NISSAN/DATSUN dealer or other competent service facility.

CHECKING BRAKE PEDAL DISTANCE

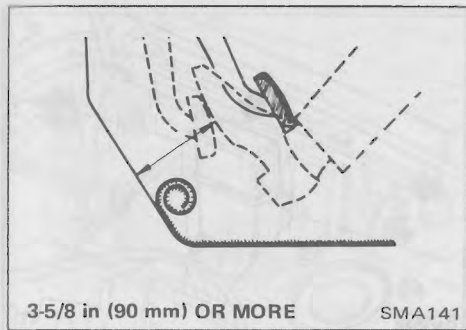

When the brake pedal is fully depressed [depressing force of 110 lb (490 N)] with the engine running, the distance between the upper surface of the pedal and the melt sheet should be as shown in the illustration.

When this distance approaches the prescribed limit value, have the brake checked by your authorized NISSAN/DATSUN dealer or other competent service facility. If the distance should abruptly be shortened, there is something wrong with the brake system. Stop driving your vehicle immediately.

Your vehicle is equipped with power assisted brakes. Braking effort with engine off will require greater pedal force.

AMH00703

CHECKING BRAKE BOOSTER FUNCTION

Check the brake booster function in accordance with the following procedures:

1. Park the vehicle on a level surface and set the parking brake.
2. With the engine stopped, depress the brake pedal several times to make sure that the pedal travel distance does not change. Then, while depressing the brake pedal, start the engine. At this time, the pedal should go down a little.
3. Depress the brake pedal while running the engine. With the brake pedal depressed, stop the engine. Keeping the pedal depressed for about 30 seconds, make sure that the depressed pedal height does not change.
4. Run the engine for a minute and then stop it. Depress the brake pedal several times and make sure that the pedal travel distance decreases gradually with each depression.

If the brake does not operate properly, have the brake system checked by your authorized NISSAN/DATSUN dealer or other competent service facility.

CHECKING CLUTCH PEDAL FREE TRAVEL

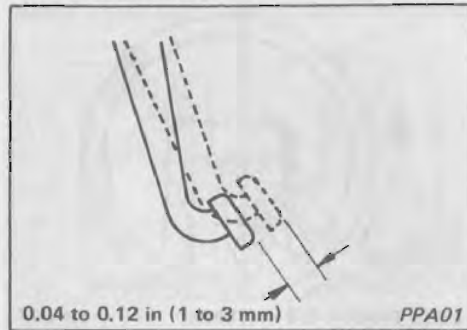

The clutch pedal should have the amount of free travel shown in the illustration. Check it by depressing the pedal by hand. If free travel is too little or too much, have the clutch checked by your NISSAN/DATSUN dealer or other competent service facility.



CHECKING STEERING WHEEL PLAY

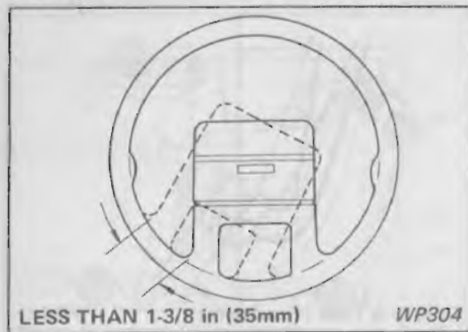

With the steering wheel in straight ahead position, measure the amount of steering wheel play. Turn the steering wheel in both directions within the range where the front tires remain stationary as seen with the eyes; the amount of circumferential movement of the steering wheel at this time is the steering wheel play.

If the play is greater than that shown above, have the steering wheel adjusted by your authorized NISSAN/DATSUN dealer or other competent service facility.

If your vehicle is equipped with power assist steering, greater steering effort will be required if engine is off.

CHECKING FUSES

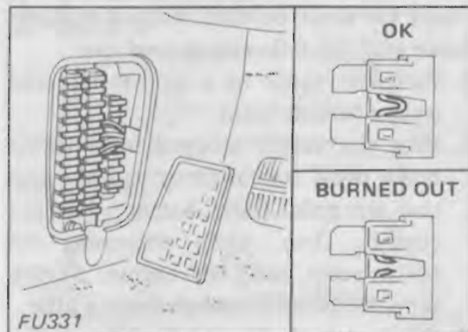

Should an electrical failure occur, check for a burned-out fuse. Fuses are located as shown in the illustration.

1. Remove the fuse and check. If it is burned out, replace it.

Before replacing any fuse, be sure to check the fuse specifications listed on the fuse box cover. Never use a fuse of higher amperage rating than that specified.

Snap fuses into their fuse holders securely.

2. Should a replacement fuse burn out again, have the electrical system checked and repaired by your authorized NISSAN/DATSUN dealer or other competent service facility.

CHECKING FUSIBLE LINKS

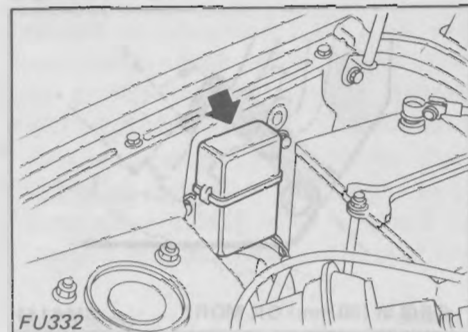

When electrical failure has occurred and fuses are in good order, check the condition of the fusible links. Fusible links are located as shown in the illustration. Should an overload occur, these fusible links melt, preventing damage to the wiring harness, electronic fuel injection system and electrical equipment. Replace a fusible link only with a genuine NISSAN part or one of an equal rating.

BULB REPLACEMENT

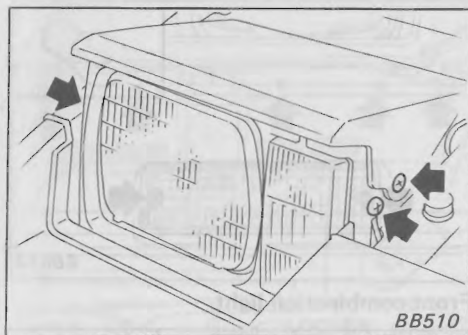

HEADLIGHTS

The headlight is a sealed beam type in which the lens, reflector and filament are of a unitized construction.

1. Turn on the retractable headlight switch.

After the headlights are open, disconnect the battery ground cable.

2. As shown in the illustration, remove the screws attaching the headlight finisher, and remove the headlight finisher. When removing the headlight finisher, push down on the finisher and pull out on the upper part of the finisher while pulling up the headlight cover, then remove it.

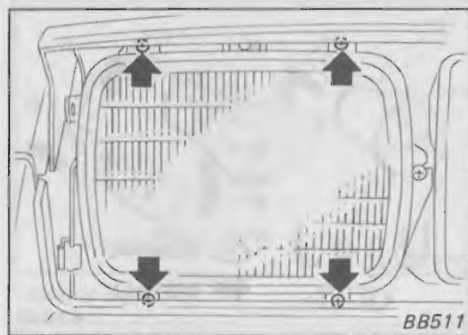

Be careful not to break the finisher when removing it.

3. Loosen the screws which hold the headlight retaining ring and take off the headlight.
4. After removing the headlight from the mounting ring, remove the wiring connector from the rear end of the bulb.

Be careful not to disturb the aiming adjusting screws.

5. When installing the new unit, be sure that the raised letters on the lens can be read normally.

When aiming adjustment is necessary, see your NISSAN/DATSUN dealer or other competent service facility.

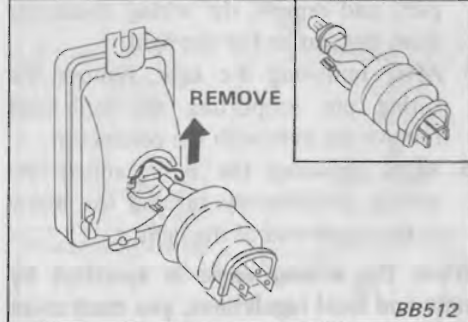
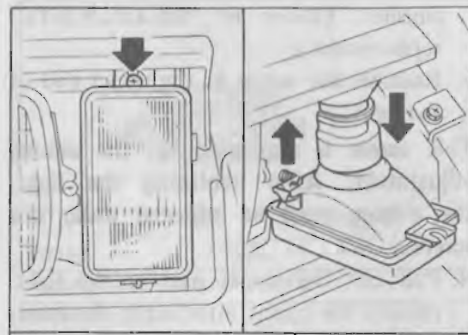

AUXILIARY DRIVING LIGHT

1. Turn on the retractable headlight switch.

After the headlights are open, disconnect the battery ground cable.

2. Remove the screws holding the headlight finisher, and remove the headlight

finisher. (Refer to "HEADLIGHTS" replacement.)

3. Remove the screw in the upper end of the light.

This screw is also used for the aiming adjustment. After replacing the light, the aiming must be adjusted using this screw.

4. Pull out the upper part of the light, remove the spring attached to the lower part, and remove the wiring connector from the rear end of the light.
5. After removing the light, remove the spring pin supporting the bulb and remove the bulb with the connector.
6. After replacing the bulb, adjust the aiming properly by turning the screw in the upper end of the light.

When the aiming angle is specified by state and local regulations, you must make these adjustments according to the regulations.

If you cannot adjust the headlights to the proper aiming angle by yourself, see your NISSAN/DATSUN dealer or other competent service facility.

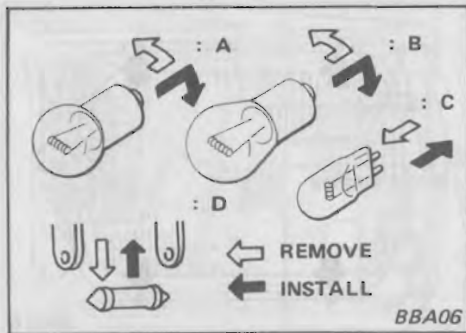

OTHER LIGHTS

All other lights are either type A, B, C or D. When replacing a bulb, first remove the lens and/or cover.

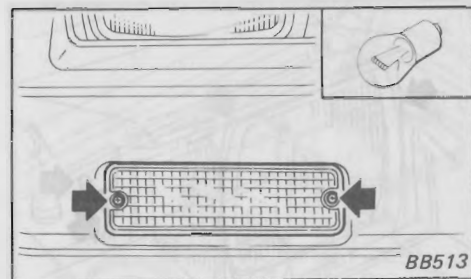

Front combination light

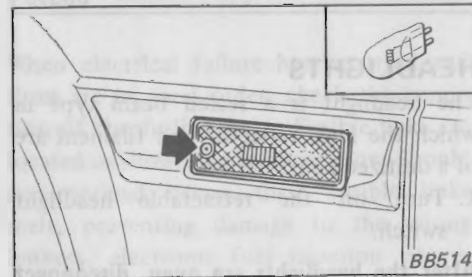

Front side marker light

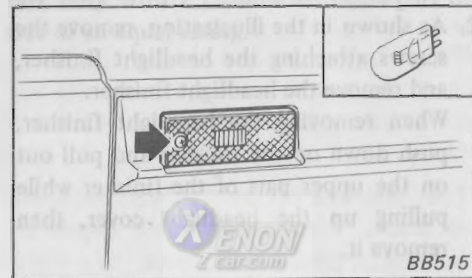

Rear side marker light

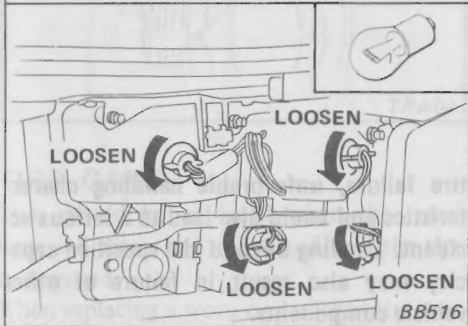
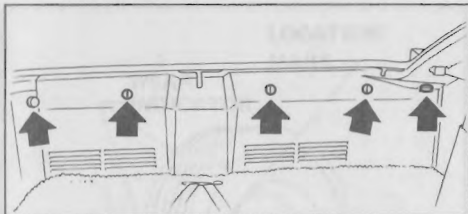

Rear combination light

BB516

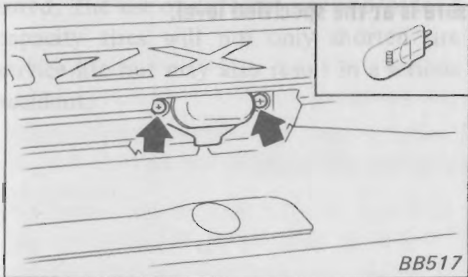

License plate light

AMH00707

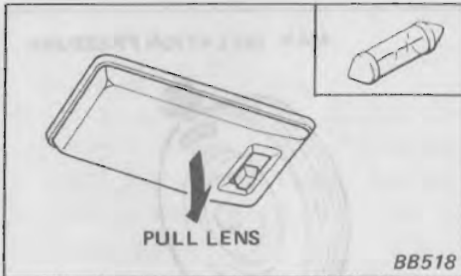

Interior light

BB518

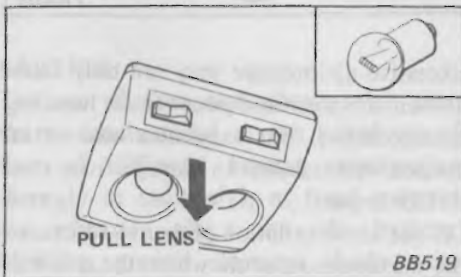

Spot light

BB519

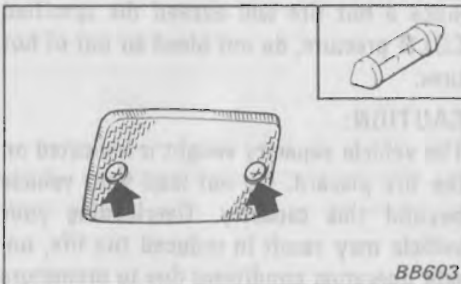

Door step light

BB603

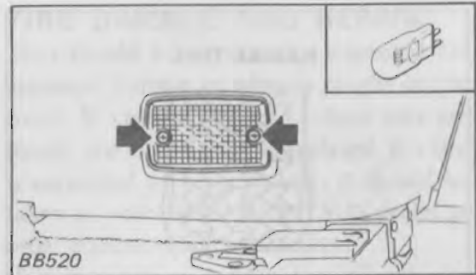

Luggage compartment light

BB520

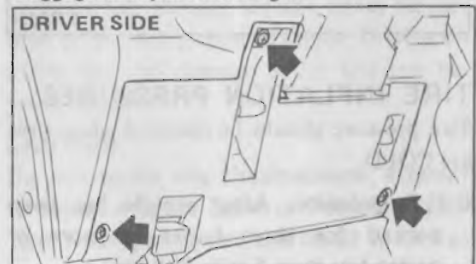

PASSENGER SIDE

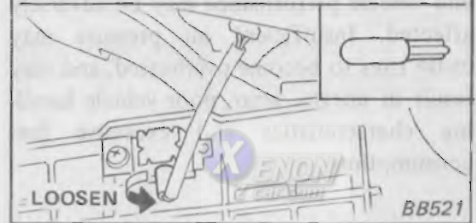
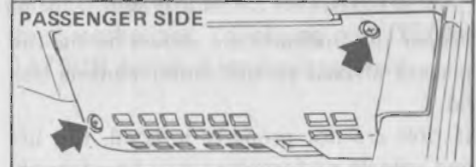

Leg room light

BB521

WHEELS AND TIRES



TIRE INFLATION PRESSURES

Tire pressure should be checked when tires are COLD.

COLD pressure: After vehicle has been parked for three hours or more or driven less than 1 mile (1.6 km).

Proper tire pressures are shown on the tire placard affixed to the center console box lid.

If tires are not properly inflated, tire life and vehicle performance may be adversely affected. Insufficient air pressure may cause tires to become overheated, and may result in uneven wear, poor vehicle handling characteristics and excessive fuel consumption.

AMH00708



Excessive air pressure may not only cause uneven tire wear and poor vehicle handling characteristics, but may also lead to increased vulnerability to damage from road surface impact.

Do not allow inflation pressures to exceed the maximum value shown on the side wall of the tire.

Since a hot tire will exceed the specified COLD pressure, do not bleed air out of hot tires.

CAUTION:

The vehicle capacity weight is indicated on the tire placard. Do not load your vehicle beyond this capacity. Overloading your vehicle may result in reduced tire life, unsafe operating conditions due to premature

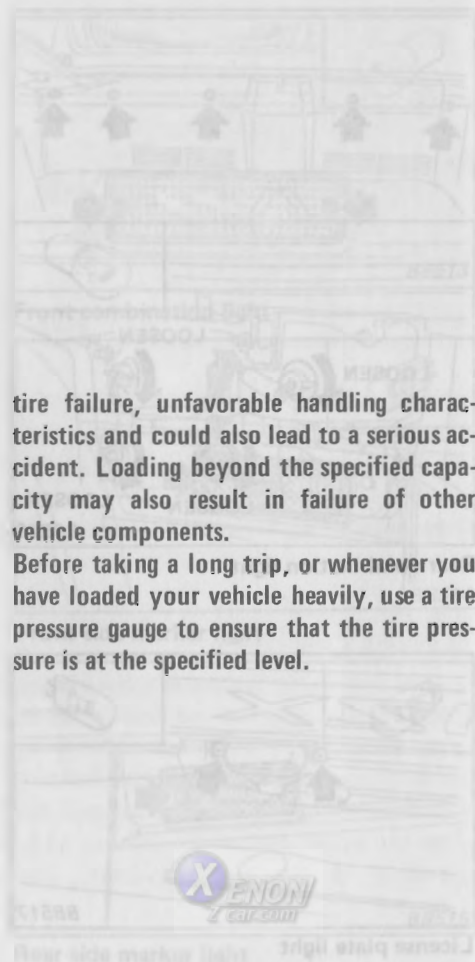

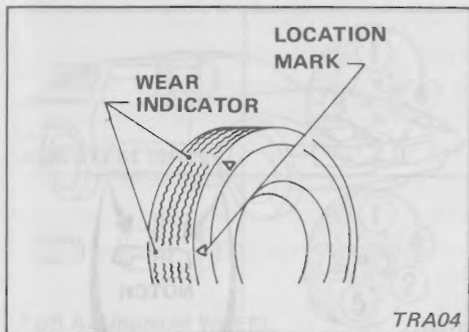

TIRE CARE

Tire should be replaced when the tread wear indicators are visible and/or if the tire is damaged.

When replacing a worn or damaged tire, use a replacement tire of the same size and load carrying capacity as that with which the vehicle was equipped when manufactured. The use of different size and/or load capacity tires will not only shorten tire service life but may also result in a serious accident.

CAUTION:

The use of tires and wheels other than those recommended or the mixed use of tires of different brands, construction (bias-ply or radial-ply), or tread patterns can adversely affect the ride, braking, handling, ground clearance, body-to-tire clearance, and speedometer calibration.

TIRE DAMAGE AND REPAIR

Tires should be periodically inspected for cracking, bulging or objects caught in the tread. If cracks, bulging or deep cuts are found, the tire should be replaced. If a tire is suspected of being unsafe, it should be taken to your NISSAN/DATSUN dealer or other competent service facility.

If a blowout or sudden loss of pressure occurs while driving, do not travel further than is necessary to stop safely. Driving on a flat tire can damage a tire and rim beyond repair.

CAUTION:

Do not, under any circumstances, attempt to repair a Space Saver or Foldable Spare Tire. Improper service can result in serious personal injury. Contact authorized Bridgestone, authorized Yokohama or NISSAN/DATSUN dealers if service is required.



TIRE ROTATION

Periodic rotation of tires will result in longer tire life. Tires should be rotated as recommended in the illustrated rotation system.

As to the tire rotation interval, refer to "Maintenance Schedule" section.

CAUTION:

- All the tires should be of the same type.
- Bias, bias belted and radial-ply tires must not be mixed under any circumstances.
- Do not include the Sapce Saver Spare tire when rotating tires.

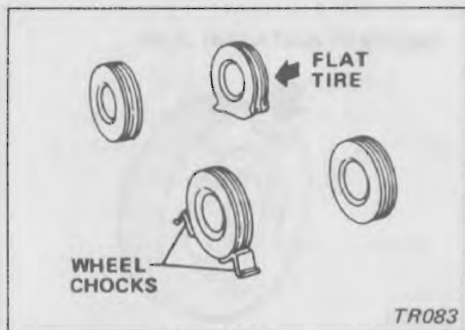

CHANGING TIRES

When changing tires, carefully take the following steps.

1. Park on a level surface, set parking brake firmly and turn off engine. Set manual transmission in reverse (automatic transmission in "P").
2. If parked on or near road, activate hazard warning flasher.
3. Remove the spare tire and jacking equipment from the stowage compartment.

The spare tire is designed for emergency use. Refer to specific instructions under the heading "TIRE DAMAGE AND REPAIR".

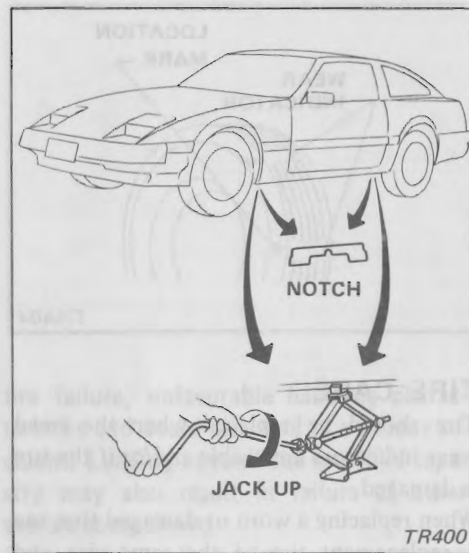

4. Place wheel chocks at both the front and back of the wheel diagonally opposite the jack position.
5. Place the jack under the jack-up point indicated.

Carefully read the caution label attached to the jack body.

6. Using the flat end of the wheel nut wrench, remove the wheel cover and loosen the wheel nuts one or two turns

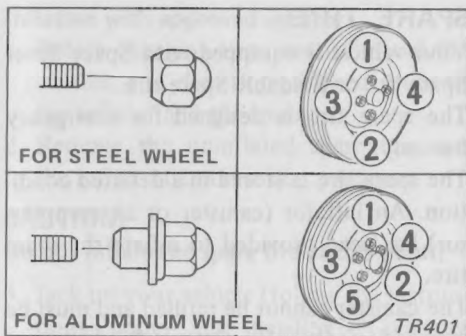

each by turning them counterclockwise.

- Do not remove wheel cover with bare hands.
- Do not remove the wheel nut until the wheel is raised off the ground.

7. Raise the vehicle slowly until the wheel clears the ground. Remove the wheel nuts and replace the wheel.

WARNING:

Never get under the vehicle while it is supported only by the jack.

Do not start or run engine while vehicle is on the jack.

8. Reinstall the wheel nuts as shown in the illustration and tighten them in the sequence indicated as much as you can by hand. AMH00711

- If NISSAN aluminum wheels are installed, use only wheel nuts designed for your aluminum wheels.

- Pull the wheel back to properly align the nuts with the bolt holes, then hand-tighten the aluminum wheel nuts until they fit securely into holes on the aluminum wheel.

9. Then slightly tighten the wheel nuts alternately and evenly until there is no wheel play.
10. Lower the vehicle slowly until the wheel touches the ground, and then tighten the wheel nuts to the specified torque in a criss-cross fashion.

- Use the NISSAN wheel nut wrench to tighten the nuts.
- As soon as possible after changing wheels, have a technician tighten the wheel nuts to the specified torque with a torque wrench.

Tightening torque:

Wheel nut 72 to 87 ft-lb
(98 to 118 N-m)

- Be sure to check the wheel nuts for tightness, after the aluminum wheel has been run for the first 600 miles (1,000 km) (also in cases of repairing flat tires,

tire rotation, etc.). Retighten if necessary.

11. Adjust the tire pressure to the specified value indicated on the tire placard. Remove the wheel chocks, and replace the tools and spare tire.

CAUTION:

Always make sure that the spare tire and jacking equipment are properly secured after use. Such items can become dangerous projectiles in a serious accident.



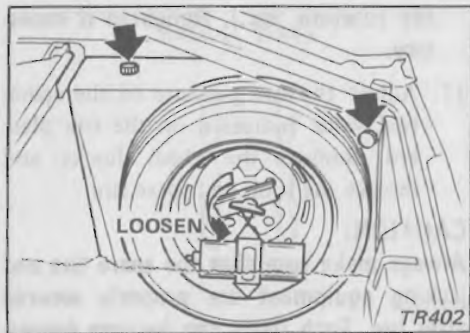

SPARE TIRE/JACK STOWAGE

The spare tire and inflator are located on the right side of the luggage compartment. Remove the inside trim, then release the spare tire clamp. The jack, jack handle, wheel chocks, wheel nuts, road wheel nut wrench and spark plug wrench are placed on the left side of the luggage compartment under the carpet.

To eliminate the possibility of the jack, inflator, wheel chocks etc., rattling while the vehicle is moving, stow them securely.

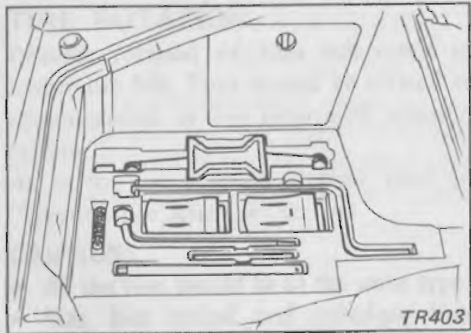

SPARE TIRE

Your vehicle is equipped with Space Saver Spare tire or Foldable Spare tire.

The spare tire is designed for emergency use only.

The spare tire is stored in a deflated condition. An inflator (canister or air compressor) has been provided to inflate the spare tire.

The canister cannot be refilled and must be replaced after each inflation. Replacement canisters may be purchased from your NISSAN/DATSUN dealer or any authorized tire dealer. Be sure you obtain the proper size canister for your spare tire size. After properly installing the spare tire, drive to the nearest service station for repair or replacement of the conventional tire. When the conventional tire has been reinstalled, the spare tire should be deflated and stowed for future use.

CAUTION:

The spare tire is designed for emergency use and short distance driving only. Do not exceed 50 MPH (80 km/h) with the spare tire installed.



Inflation with approved inflator

1. Before changing tires, carefully read the caution and directions affixed on both the inflator and the spare tire.
2. Remove the uninflated spare tire and the inflator from rear compartment.

CAUTION:

Do not inflate the spare tire at this point.

3. Jack up your vehicle (follow the instructions under the heading "Changing Tires") and remove the damaged tire.

Then mount the uninflated spare tire to the axle. (Tighten wheel nuts slightly.)

CAUTION:

If your vehicle is equipped with aluminum wheels, be sure to use the spare tire wheel nuts in the tool bag. Never use the wheel nuts for aluminum wheel on the spare tire wheel.

The spare tire wheel may come off the axle and cause personal injury if the wheel nuts for aluminum wheels are used on the spare tire wheel.

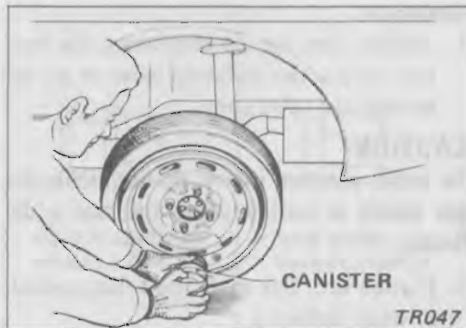

USING CANISTER

- 1) With tire valve at 6 o'clock position, inflate the spare tire with the canister. Place tire inflator on the tire inflation valve and push squarely until gas can be heard entering the tire. The spare tire may be inflated in about 3 minutes.

CAUTION:

The metal parts of the canister become extremely cold during inflation and can cause frost bite. Avoid contact with the metal, and use a glove or other means of protection.

- 2) To ensure complete emptying of the canister, hold the canister on tire valve for one minute after sound of gas stops.

If the temperature is below 10°F (-12.2°C), the canister must be warmed

with the windshield defroster for five to ten minutes.

- 3) Lower the vehicle in accordance with the jacking instructions and fully tighten the wheel nuts.
 - a) Do not install the wheel cover on the spare tire.
 - b) In cold weather, the tire may not look fully inflated. Therefore, drive slowly for the first mile; as the tire temperature rises the pressure will increase.

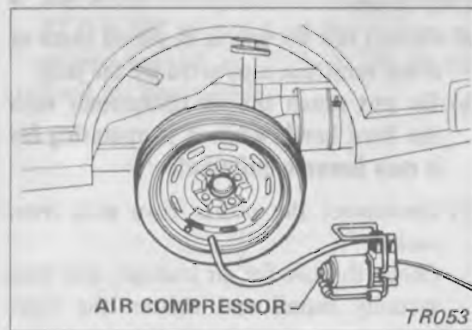

USING AIR COMPRESSOR

- 1) Remove the valve cap from the spare tire and securely connect the air compressor hose in its place.
- 2) Connect the power cord plug of the air compressor to the cigarette lighter

socket. The spare tire may be inflated to the recommended pressure 28 psi (200 kPa) in about 5 minutes. Adjust the tire pressure per the tire placard with tire pressure gauge.

If the air compressor operation is slow, run the engine while the air compressor is operating.

In this case, lower the vehicle and fully tighten the wheel nuts. Then remove the jack before starting the engine.

CAUTION:

- a) Do not run the engine in closed space or if the vehicle is supported by the jack.
 - b) Do not touch the air compressor with the bare hands while it is operating for it may become quite hot.
- 3) Disconnect the power cord plug from socket.
Check the tire for air leakage, and then securely install and tighten the valve cap.
 - 4) Lower the vehicle in accordance with the jacking instructions and fully tighten the wheel nuts.

Do not install the wheel cover on the spare tire.

AMH00714

Deflation

1. Deflate the tire by depressing the button on the tire inflation valve or by removing the valve core.

CAUTION:

To avoid personal injury, do not inhale the gas which is vented while the tire is deflating.

2. Flatten tire. The spare tire folds gradually while deflating.
3. Store tire in rear compartment.

Repair

Repairing, mounting, or dismantling of the spare tire on the wheel is not recommended under any circumstance.

Improper service can result in serious personal injury.

Contact authorized Bridgestone, authorized Yokohama or NISSAN/DATSUN dealers if service is required.

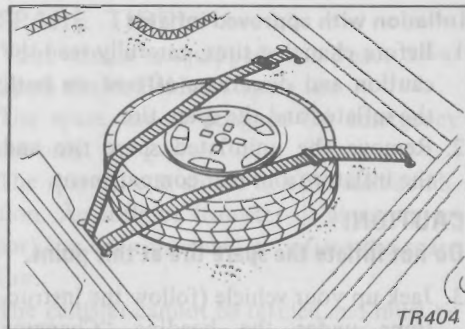

CAUTION:

When stowing a tire replaced by a spare, the tire should be placed in the baggage area and secured with baggage straps, as illustrated. This will reduce the likelihood of the tire being thrown about and injuring occupants in an accident.



CHANGING WHEELS

When selecting new tires or wheels, pick only those types and sizes recommended in "Wheels and Tires" under the heading "Specifications". The wheels should be equal in load limit, diameter, width, offset, and mounting configuration to those recommended. A wheel of the wrong size may adversely affect wheel and bearing life, braking and stopping ability, handling characteristics, ground clearance, body-to-tire clearance, snow chain clearance, speedometer calibration, headlight aim and bumper height.

- Do not install a deformed wheel even if it has been repaired. Such wheels could have structural damage and could fail without warning.
- Do not use an inner tube on a tubeless tire wheel.
- Avoid installing a used wheel. If the wheel has been used under severe operating conditions, its life may have been significantly shortened and could fail without warning.

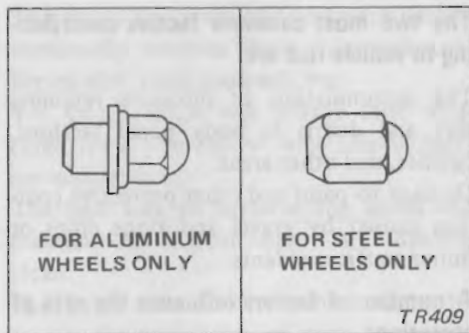

CARE OF ALUMINUM WHEELS

Wash the wheels while washing the rest of the vehicle to maintain their appearance. Clean the inner side of the wheels each time one is changed or the underside of the vehicle is washed.

CAUTION:

- Do not use abrasive cleaners when washing the wheels.
- Inspect wheel rims regularly for dents or corrosion, which may cause loss of pressure, damage the tire bead, or sudden wheel failure.
- Consider the application of vehicle wax to protect against the road salt used during winter.

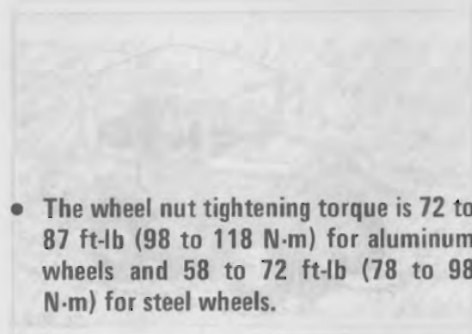

Appearance And Interior Care



AMH00716

RUST AND CORROSION

The two most common factors contributing to vehicle rust are:

The accumulation of moisture retaining dirt and debris in body panel sections, cavities, and other areas.

Damage to paint and other protective coatings caused by gravel and stone chips or minor traffic accidents.

A number of factors influence the rate of corrosion:

Moisture

Remember, even when the vehicle surface appears dry, areas which have accumulated dirt and water will remain moist or damp for long periods.

The underbody and floor sections of the vehicle should be thoroughly checked. Floor sections which have snow and ice trapped under the matting will not dry.

Drain holes located at the bottom of doors and tailgates can become clogged, trapping water inside and causing the lower sections to rust.

Relative humidity

Corrosion will be accelerated in areas of high relative humidity, especially those areas where the temperatures stay above the freezing point and where atmospheric pollution and road salt use is highly evident. Parts of the vehicle covered with road dirt containing de-icing agents will corrode much more quickly at a lower relative humidity than those parts of the vehicle which have been cleaned.

Temperature

A temperature increase will accelerate the rate of corrosion to those parts of the vehicle which are not well ventilated to permit fast drying.

Air pollution

Industrial pollution, the presence of salt in the air in coastal areas, or in areas of heavy salt use will accelerate the corrosion process. Road salt will also accelerate the disintegration of paint surfaces.

These factors identify the necessity for every vehicle owner to keep their vehicles as clean as possible, to pay particular attention to the underbody and to repair minor damage to the paint or protective coatings quickly.

CLEANING YOUR VEHICLE

High relative humidity, air pollution, temperatures regularly above freezing, or the use of road salts for de-icing all increase the chance for corrosion. In those areas that experience any of the above conditions the need for vehicle care is increased.



The finish and upholstery on your vehicle continually receives abuse from industrial fumes, dirt, mud, road salt, etc.

Yet your vehicle will always look well-cared for if you follow these helpful hints on vehicle care.

The best way to preserve the finish and maintain its original beauty is to keep it clean.

The longer dirt is left on the surface, the greater the probability of some damage to the finish.

In areas where excessive road salt is used or where sea winds blow, the vehicle should be cleaned more often to protect the finish.

- The underside of the vehicle also picks up dirt and road salt which should not be allowed to build up.

Therefore, the underside of the vehicle should be sprayed with a powerful jet of water, at regular intervals, to remove these corrosive deposits.

- Particular attention should be paid to underfender areas where dirt and mud deposits, thrown up by the road wheels, are heaviest.
- Ensure that door and body drain holes are clear and free from obstruction.

- Inspect condition of undercoating protection and respray where required.

Have the underside of your vehicle inspected regularly by a qualified mechanic.



WASHING

Your vehicle should be washed at regular intervals. In adverse conditions, if the weather permits and appropriate facilities are available, your vehicle should be washed at least once a week.

Do not wash your vehicle in the direct rays of the sun.

Using a jet of water, loosen the dirt from the underbody.

Rinse the entire body of the vehicle until the dirt has been loosened.

Wash off the dirt with a sponge and plenty of water.

Clean the vehicle thoroughly using a mild soap or detergent (a special vehicle soap or general purpose dish-washing liquid) mixed with clean, lukewarm (never hot) water.

Rinse the vehicle thoroughly with plenty of clean water.

After each washing, check the drain holes on the bottom of the doors and tailgates to make sure that they are clear and can drain properly. Inspect all weatherstripping and window mouldings to ensure that they are preventing water from entering the body panels.

In case of extremely cold weather, ensure that the vehicle is thoroughly dried to prevent the door locks, rubber door seals and other rubber seals from freezing and becoming damaged.

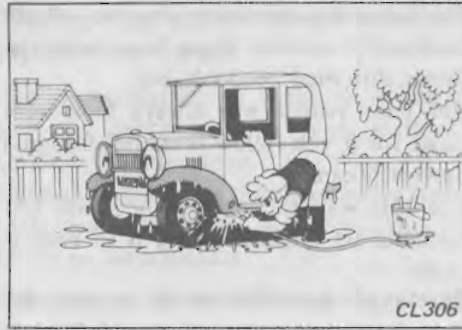

During the winter months it is especially important to clean the underbody with high pressure water or steam. This should include the wheel housings, bumpers, muffler, tailpipe and brackets. The underbody should be washed in this manner at least once during the winter and once after, although more often would be preferable.

CAUTION:

If these cleanings only wet the caked mud and debris instead of removing it, the possibility of corrosion will increase not decrease.

If you are unable to clean the underbody yourself, locate a vehicle wash equipped to perform this service.

Re-cycled cleaning solutions which have not been adequately treated have proven to be contributing factors to corrosion. Check with your vehicle wash operator.

This recommendation also applies to vehicles used in areas with above average concentration of atmospheric salts and areas having above normal levels of atmospheric corrosives such as sulphur dioxide.



INSPECTING BODY SURFACE

Inspect body surface for stone chips and parking lot damage, and have spot repairs carried out as soon as possible.

REMOVING SPOTS

Remove spots from the painted surface as soon as possible to prevent staining.

Tar or road oil

Remove tar or oil immediately as permanent staining may result.

Use a tar and road oil remover. If you do not have a remover, use turpentine. Then wash with a soap and water solution. Wax to preserve the finish.

Insects or tree sap

Remove with a lukewarm soap and water solution. Do not allow tree sap to harden on the paint surface.

WAXING

Apply liquid wax or paste wax to obtain a long-lasting, durable finish.

Wax at periodic intervals, depending on the environment where your vehicle is used.

At a minimum, the vehicle should be waxed twice yearly.

To keep the beautiful appearance of the urethane or polypropylene bumper, observe the following precautions:

- Only black wax or black shoe wax should be used as other waxes may produce a stain.
If wax is splashed on the bumper by an automatic car washer, apply a black wax or black shoe wax as soon as possible.
- If you spill brake fluid or battery electrolyte on the bumper, clean it off immediately with water.
- When cleaning the bumper, do not use abrasive cleaners. As the bumper exterior is soft, clean carefully to avoid scratches.
- Keep the bumpers away from high temperatures. Before baking on new paint, be sure to remove the bumpers.

VINYL AND LEATHER TRIM (SEAT)

- Occasionally remove loose dust from the interior trim and seats using a vacuum cleaner or soft brush. Regularly wipe the vinyl and leather surfaces with a clean, soft cloth.
- The leather seats should be regularly coated with a leather wax. **Never use car wax.**

- Remove ordinary stains with lukewarm water and a mild soap (or 1 to 3% of neutral detergent solution). Wipe with a damp, clean, soft cloth to remove traces of soap and then wipe clean with a dry cloth. **Never use benzine, thinner or any similar material.**

CLOTH UPHOLSTERY AND CARPET

Clean with a vacuum cleaner or hard brush. Stains should be removed with a soap and water solution or a spot remover. Wipe with a damp, clean cloth from outside of stain toward center.

Refer to the seat belt section of this manual for seat belt cleaning instructions.

CAUTION:

Only use spot removing fluids in a well ventilated area and keep out of the reach of children.

Do not use gasoline, kerosene, naphtha, nail polish remover or other volatile cleaning fluids. They may be toxic or flammable or hazardous in other ways.



PAINT REPAIR



REPAIRING SURFACE DAMAGE

Washing your vehicle regularly will provide you with an opportunity to inspect the painted surface of your vehicle for stone chips, scratches, parking lot damage, etc. These should be repaired quickly by a qualified body repair shop.

ADDITIONAL INFORMATION



PASSENGER AND CARGO COMPARTMENTS

Not all corrosion begins on the outside of your vehicle. Moisture is often trapped under the floor and luggage compartment mats and, if allowed to remain, will eventually corrode and weaken the floor and luggage compartment panels. If moisture is evident in these areas, remove any loose protective mats and allow them, and the areas under them, to dry. A wet type vacuum cleaner may be used.

Certain cargo such as chemicals, fertilizers, cleaners, de-icing salts, etc. are extremely corrosive. Transporting these makes it necessary for owners to take special precautions to protect their vehicles from the related corrosion.



KEEPING THE VEHICLE IN A GARAGE

It is difficult to generalize on whether or not to keep a vehicle indoors.

If your garage is damp because of poor ventilation or if you often wash your vehicle there or drive it in to the garage before removing the snow, then it is probably better to keep your vehicle outdoors, especially when the temperature is below freezing.

Specifications

VEHICLE IDENTIFICATION PLATE LOCATION

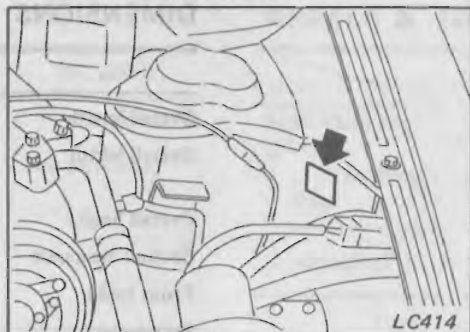

The vehicle identification plate is located as shown in the illustration.

F.M.V.S.S. CERTIFICATION LABEL LOCATION

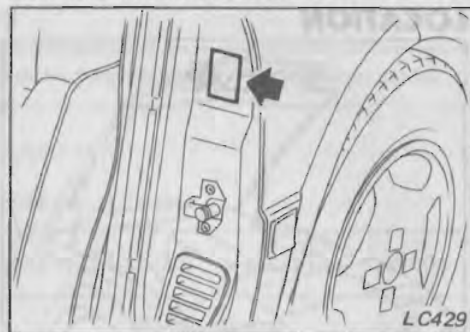

The F.M.V.S.S. certification label is affixed as shown in the illustration.

VEHICLE IDENTIFICATION NUMBER PLATE LOCATION

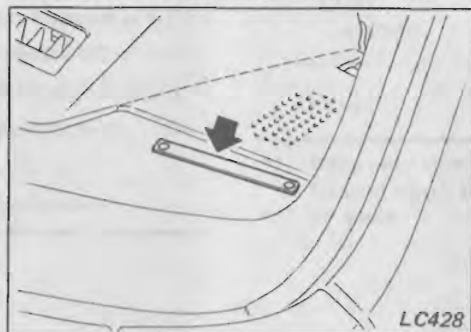

The vehicle identification number plate is attached as shown in the illustration.

ENGINE SERIAL NUMBER LOCATION

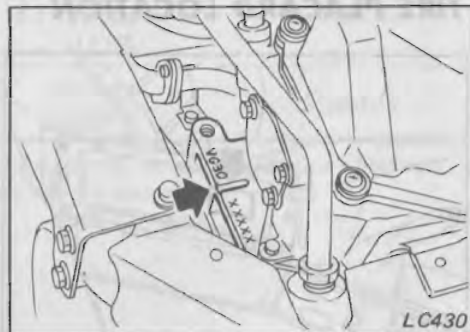

The engine number is stamped as shown in the illustration.

WEIGHTS

Model	Weight (kg)	Weight (lb)
LC414	170.7 (376.8)	376.8 (831.1)
LC429	170.7 (376.8)	376.8 (831.1)
LC428	170.7 (376.8)	376.8 (831.1)
LC430	170.7 (376.8)	376.8 (831.1)

ENGINE

Model	Cylinder arrangement	Type	Bore x Stroke (mm)	Displacement (cc)
LC414	6-cyl	OHV	70.0 x 80.0	3,420
LC429	6-cyl	OHV	70.0 x 80.0	3,420
LC428	6-cyl	OHV	70.0 x 80.0	3,420
LC430	6-cyl	OHV	70.0 x 80.0	3,420

*: Models equipped with turbocharger

EMISSION CONTROL INFORMATION LABEL LOCATION

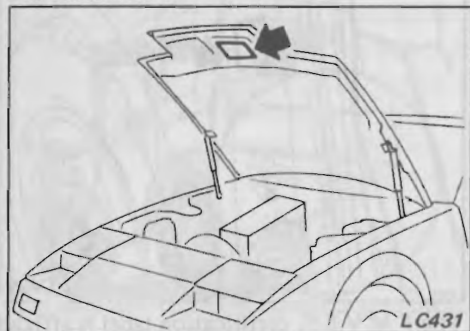

The emission control information label is attached as shown in the illustration.

TIRE PLACARD LOCATION

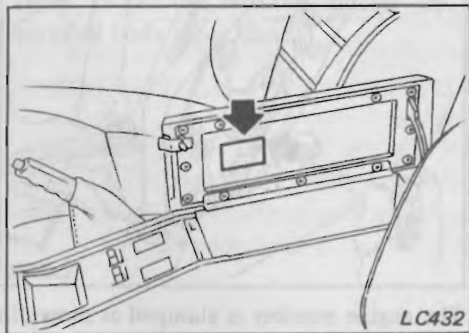

The tire placard label is attached to the inside of the glove box lid.

SPECIFICATIONS

DIMENSIONS

		2 seater	2+2 seater
Overall length	in (mm)	170.7 (4,335)	178.5 (4,535)
Overall width	in (mm)	66.5 (1,690), 67.9 (1,725)*	66.5 (1,690), 67.9 (1,725)*
Overall height	in (mm)	51.0 (1,295)	51.6 (1,310)
Ground clearance	in (mm)	5.9 (150)	5.9 (150)
Front tread	in (mm)	55.7 (1,415)	55.7 (1,415)
Rear tread	in (mm)	56.5 (1,435)	56.5 (1,435)
Wheelbase	in (mm)	91.3 (2,320)	99.2 (2,520)
Turning circle [wall to wall]	ft (m)	34.8 (10.6)	37.4 (11.4)

*: Model with side molding



WEIGHTS

	2 seater	2+2 seater
Gross Vehicle Weight Rating		
lb (kg)		
Gross Axle Weight Rating	See the "F.M.V.S.S. certification label".	
Front	lb (kg)	
Rear	lb (kg)	
Seating capacity	persons	
	2	4

ENGINE

Cylinder arrangement	6-cylinder, V-slanted at 60°	
Type	4-cycle OHC	
Bore x Stroke	in (mm)	3.425 x 3.268 (87.0 x 83.0)
Displacement	cu in (cm ³)	180.62 (2,960)
Compression ratio	9.0, 7.8*	
Firing order	1-2-3-4-5-6	

*: Models equipped with turbocharger

WHEELS & TIRES

	Non-turbocharger model	Turbocharger model
Road wheel size		
... Offset		
in (mm)		
Steel	5-1/2-JJ-14 ... 1.18 (30)	-
Aluminum*1	6-1/2-JJ-15 ... 1.18 (30)	6-1/2-JJ-15 ... 1.18 (30)
Tire	Type	Radial, tubeless
Size	P195/70R14 P215/60R15	P215/60R15
Spare tire		
Road wheel size	5-J x 14 (Steel)	5-J x 15 (Steel)
... Offset	... 1.18 (30)*2	... 1.18 (30)
in (mm)	5-J x 15 (Steel) ... 1.18 (30)	
Tire size	C78-14*2 155/90D15	155/90D15

*1: When using aluminum road wheels, be sure to carry four wheel nuts for steel wheels for use with the spare tire.

*2: SF model

SERVICE DATA

ENGINE TUNE-UP

Idle speed	rpm	See the "Emission Control Label" on the underside of the hood.	
Ignition timing (B.T.D.C.)	degree/rpm		
CO percentage at idle speed	[No air] (%)		
Spark plug gap	in (mm)	0.039 to 0.043 (1.0 to 1.1)	
Non-turbocharger model	BCPR5ES-11*2		
	BCPR6ES-11*2		
	BCPR7ES-11*2		
Turbocharger model	BCPR5E-11*2		
	BCPR6E-11*2		
	BCPR7E-11*2		
Drive belt deflection		Adjust deflection of used belt	Set deflection of new belt
		0.24 to 0.31 (6 to 8),	0.20 to 0.28 (5 to 7),
Alternator	in (mm)	0.24 to 0.35 (6 to 9)*1	0.20 to 0.31 (5 to 8)*1
Air conditioner compressor	in (mm)	0.35 to 0.43 (9 to 11)	0.28 to 0.35 (7 to 9)
Power steering oil pump	in (mm)	0.51 to 0.63 (13 to 16)	0.39 to 0.51 (10 to 13)
Applied pushing force	lb (N)	22 (98)	
Alternator belt size Width x Length	in (mm)	0.551 x 37.20 (14.0 x 945)	
		0.5606 x 40.47	
		(14.24 x 1,028)*1	

*1: Turbo model AMH00724 NGK make

CAPACITIES

	US measure	Imp measure	Liter
Fuel tank	19 gal	15-7/8 gal	72
Coolant			
Non-turbo model	11-1/8 qt	9-1/4 qt	10.5
Turbo model	11-5/8 qt	9-5/8 qt	11.0
Reservoir tank	7/8 qt	3/4 qt	0.8
Engine			
With oil filter	4-1/4 qt	3-1/2 qt	4.0
Without oil filter	3-7/8 qt	3-1/8 qt	3.6
Transmission			
M/T	4 pt	3-3/8 pt	1.9
A/T	7-3/8 qt	6-1/8 qt	7.0
Differential carrier	2-3/4 pt	2-1/4 pt	1.3
Power steering system	1 qt	3/4 qt	0.9
Windshield and Rear window washer tank	3-1/8 qt	2-5/8 qt	3.0
Headlight cleaner washer tank	2-3/8 qt	2 qt	2.2
Air conditioning system			
Compressor oil	5.1 fl oz	5.3 fl oz	0.15
Refrigerant	2.2 lb	2.2 lb	1.0 kg



TIGHTENING TORQUE

Unit: ft-lb (N·m)

Cylinder head bolt		40 to 47 (54 to 64)
Manifold bolt and nut		
Intake*		
1st step		2.2 to 3.6 (3 to 5)
2nd step	Bolt	17 to 20 (24 to 27)
	Nut	12 to 14 (16 to 20)
Exhaust		13 to 16 (18 to 22)
Spark plug		14 to 22 (20 to 29)
Oil pan bolt		3.6 to 5.1 (5 to 7)
Oil pan drain plug		22 to 29 (29 to 39)
Transmission drain and filler plugs		43 to 72 (59 to 98)
Differential carrier drain and filler plugs		29 to 43 (39 to 59)
Wheel nut	Aluminum	72 to 87 (98 to 118)
	Steel	58 to 72 (78 to 98)

*: When tightening the intake manifold, first tighten temporarily (1st step) and then tighten the bolts and nuts to the specified torque (2nd step).

BULBS

Item	Wattage (W)	SAE trade number
Headlight	65, 35	H6054
Auxiliary driving light	55	—
Front combination light	27/8	1,157
Front side marker light	3.4	158
Rear side marker light	3.4	158
Rear combination light		
Turn signal	27/8	1,157
Stop/Tail	27/8	1,157
Back-up	27	1,073
License plate light	4.0	—
Interior light	10	—
Spot light	8	—
Rear (luggage) compartment light	3.4	—
Door step light	5	—
Leg room light	2	—

FUSES

Item	Ampere (A)
Headlight RH	10
Headlight LH	10
Headlight motor RH	15
Headlight motor LH	15
Clearance, Illumination	15
Room light	10
Hazard light	10
Horn	10
Stop light	15
Auto door lock	10
Air con. blower	15
Engine control	15
Fuel pump	10
Meter	10
Turn signal	10
A/T control	10
Auxiliary driving light	15
Theft warning	10
Audio	10
RR wiper	10
FR wiper	15
Cigarette lighter	15
Air con. control	10
RR defogger	20
Fan motor (Turbo)	15

AMH00726

FUSIBLE LINKS

Color	Usage
Black	Power supply to battery, accessory, E.F.I. circuit and ignition switch
Brown	Ignition switch
Brown	Headlight circuit
Green	Power window
Brown	E.F.I. control unit
Brown	E.F.I. injector



Consumer Information

INTRODUCTION

The figures contained in the following summary apply to all NISSAN/DATSUN vehicles in the particular group.

In compliance with the National Traffic and Motor Vehicles Safety Act (15 U.S.C. 1401, 1407) and the Canadian Motor Vehicles Safety Act, our NISSAN/DATSUN vehicles have been tested extensively and the results compiled to include all of the automobiles offered for sale in the U.S.

We believe it is essential that you carefully study the data before driving your new NISSAN/ DATSUN so that you are familiar with the potential ability of the vehicle PRIOR to using it.

The National Highway Traffic Safety Administration of the United States Department of Transportation (Department of Road and Motor Vehicle Traffic Safety, Transport Canada) has carefully evaluated the

statistics relating to the following minimum safety figures and has established specific guidelines that we, the manufacturers, must use when arriving at the figures stated in the following pages.

The following results were obtained by skilled drivers under controlled road and vehicle conditions, and may not be representative of results obtainable under other conditions.



VEHICLE STOPPING DISTANCE

This figure indicates braking performance that can be met or exceeded by the vehicles to which it applies, without locking the wheels, under different conditions of loading and with partial failures of the braking system.

The information presented represents results obtainable by skilled drivers under controlled road and vehicle conditions, and the information may not be correct under other conditions.

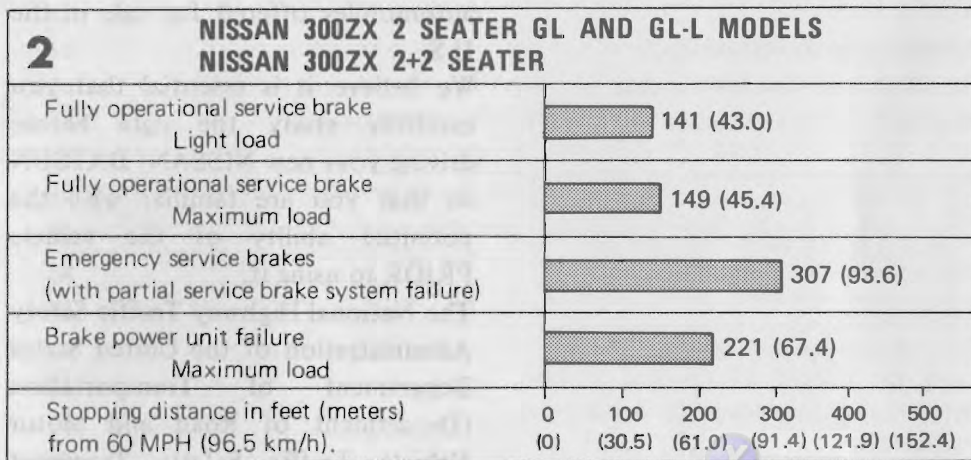
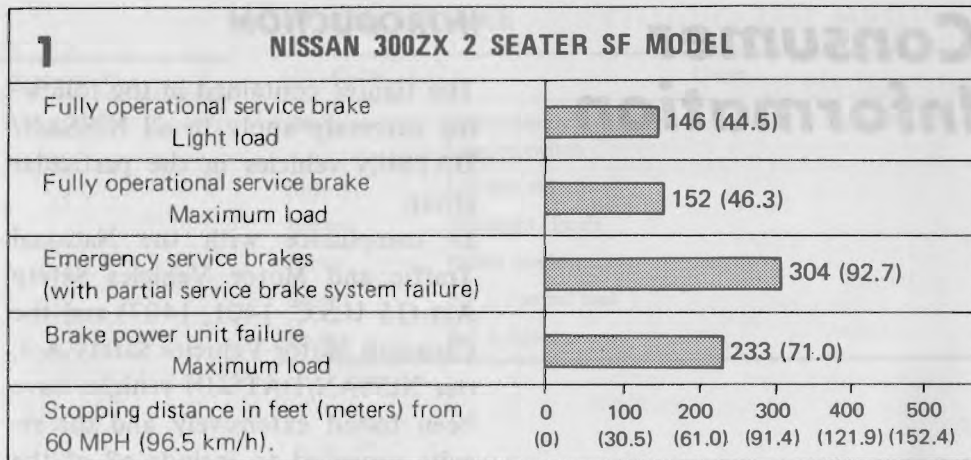

UNIFORM TIRE QUALITY GRADES FOR BIAS AND RADIAL TIRES

With the exception of Space Saver Tires, the tire quality grade assigned by the tire manufacturer is shown on the sidewall of all bias-ply or radial-ply tires.

NISSAN 300ZX 2 SEATER NISSAN 300ZX 2+2 SEATER	
Recommended tire size	P195/70R14 P215/60R15

TRACTION A, B AND C

The traction grades, from highest to lowest, are A, B and C, and they represent the tire's ability to stop on wet pavement as measured under controlled conditions on specified government test surfaces of asphalt and concrete. A tire marked C may have poor traction performance.

WARNING:

The traction grade assigned to this tire is based on straight line braking traction tests and does not include cornering (turning) traction.

TEMPERATURE A, B, AND C

The temperature grades are A (the highest), B, and C, representing the tire's resistance to heat build up and its ability to dissipate heat when tested under controlled conditions on a specified indoor laboratory test wheel. Sustained high temperature can cause the material of the tire to degenerate and reduce tire life, and excessive temperature can lead to sudden tire failure. The grade C corresponds to a level of performance which all passenger car tires must meet under the Federal Motor Vehicle Safety Standard No. 109. Grades B and A represent higher levels of performance on the laboratory test wheel than the minimum required by law.

WARNING:

The temperature grade for this tire is established for a tire that is properly inflated and not overloaded. Excessive speed, underinflation, or excessive loading, either separately or in combination, can cause heat buildup and possible tire failure.



YES, We sell FACTORY AUTHORIZED NISSAN SERVICE MANUALS

The inside story on every NISSAN designed is out. Genuine Nissan Service Manuals filled with facts, photos; diagrams, illustrations, the works. Written by the people who make the cars. And used by the ones who work on them.

Best of all, although these volumes of information are used by technicians, you don't have to be an Engineer to get the picture, it's written in plain English.

For your copy see your dealer or send check or money order payable to:

In U.S.A. Pendant Industries
P.O. Box 387,
Harbor City, Ca. 90710
(213) 530-0120

In Canada Nissan Automobile Company
(Canada) Ltd.,
P.O. Box 2600,
Streetsville Postal Station,
Mississauga, Ontario,
L5M 2L5

AMH00730

MODEL	1984 SERVICE MANUAL			1984 OWNER'S MANUAL		
	Part No.	U.S.A.	CANADA	Part No.	U.S.A.	CANADA
Stanza	20105	\$22.50	\$26.50	30110	\$2.50	\$3.00
Pick-up	20106	\$22.50	\$26.50	30111	\$2.50	\$3.00
Maxima	20107	\$22.50	\$26.50	30112	\$2.50	\$3.00
300ZX	20108	\$22.50	\$26.50	30113	\$2.50	\$3.00
Pulsar	20109	\$22.50	\$26.50	30114	\$2.50	\$3.00
200SX	20110	\$22.50	\$26.50	30115	\$2.50	\$3.00
Sentra	20111	\$22.50	\$26.50	30116	\$2.50	\$3.00
Micra	20112	(Can. only)	\$26.50	30117	(Can. only)	\$3.00

California residents add 6.5% tax.

Yes! We also have service manuals available for older models, write for a catalog.

Prices listed are for Pendant Industries and Nissan Automobile Co. (Canada) Ltd., and are suggested retail prices. Dealer prices may vary.



Index

- Adjustable shock absorber switch . . . 5-21
- Adjustment
- head restraints 2-7
 - seat 2-3
 - seat belt 2-8
 - washer spray 9-16
- Air conditioner 5-4
- Aluminum wheels 9-29
- Ash trays 5-16
- Assist grips 5-18
- Automatic transmission
- driving 4-8
 - fluid level 9-10
- Baggage strap 5-21
- Battery 9-12
- Before driving 2-1
- Before starting the engine 4-5
- Body side pocket 5-16
- Boost meter 3-5
- Brake
- fluid level 9-11, IBC
 - pedal distance 9-17
- Break-in schedule 4-1
- Bulb
- replacement 9-19
 - service data 11-5
- Capacities 11-4
- Catalytic converter 4-2
- CB radio or car phone 5-15
- Changing
- engine coolant 9-7
 - engine oil and oil filter 9-9
 - tire 9-24
 - wheel 9-29
- Checking
- automatic transmission fluid level 9-10
 - battery fluid level and condition 9-12
 - brake booster function 9-17
 - brake fluid level 9-11
 - brake pedal distance 9-17
 - clutch fluid level 9-11
 - clutch pedal free travel 9-17
 - coolant level 9-7
 - drive belts 9-13
 - engine oil level 9-8
 - fuses 9-18
 - fusible links 9-18
 - hood lock 9-16
 - parking brake condition 9-16
 - power steering fluid level 9-10
 - safety 2-1
 - steering wheel play 9-18
 - windshield/rear window/headlight cleaner washer fluid level 9-11
 - wiper blades/washer nozzles 9-16
- Cigarette lighter 5-16
- Cleaning 10-2
- Clock 5-15
- Clutch
- fluid level 9-11, IBC
 - pedal free travel 9-17
- Coat hangers 5-18
- Cold weather 4-12
- Consumer information 12-1
- Coolant temperature gauge 3-3
- Cruise control 4-14
- Defogger switch, rear 3-19
- Digital and graphic instrument 3-6
- Disc brake wear indicator 3-15
- Do-it-yourself
- precautions 9-1
- Door locks 2-2

AMH00731

precautions	9-1	gauge	3-4	Light switch	3-21
Door locks	2-2	recommendation	9-2, 14-1	Locks	
Door mirror defogger switch	3-20	Fuses	9-18	door	2-2
Drive belts	9-13	Fusible links	9-18	glove box	5-11
Driving		Gas station information	14-1	hood	9-16
automatic transmission	4-8	Glove box	5-16	rear hatch	5-19
break-in schedule	4-1	Hazard warning	6-1	Lubricant specifications	9-4
cold weather	4-12	Hazard warning flasher switch	3-24	Maintenance schedule	8-1
downhill	4-11	Head restraints	2-7	Manual transmission	4-6
economy hints	1-1	Headlight cleaner switch	3-19	Monitoring light	
hot weather	4-14	Headlights control		headlight	3-14
manual transmission	4-6	high-low beam	3-23	tail light	3-14
tips on driving	4-11	lane change	3-22	Oil	
tips on starting	4-6	passing signal	3-23	pressure gauge	3-4
uphill	4-11	Heater	5-2	recommendation	9-2
Economy hints	1-1	Hood	9-6	Ordering instructions	
Emergency, in case of		Hood lock	9-16	(Service Manual)	12-4
freeing immobilized vehicle	6-1	Hood release	14-1	Overheats, engine	6-5
jump starting	6-3	Horn	3-24	Paint repair	10-5
overheats	6-5	Hot weather	4-14	Parking	4-10
push starting	6-3	Identification plates	11-1	Parking brake	
towing	6-2	Ignition switch	4-5	condition	9-16
Emission control system	7-1	Illumination control rheostat	3-23	lever	3-24
warranty	7-2	Indicator lights		Passing signal	3-23
Engine cooling system		hazard warning	3-14	Power window	5-17
changing coolant	9-7	high beam	3-14	Push starting	6-3
coolant level	9-7, IBC	turn signal	3-14	Radio	5-11
Engine oil		Instruments and controls	3-1	Rear hatch	5-19
changing oil	9-9	Interior light	5-17	Rearview mirror	2-12
oil level	9-8, IBC	Jack	9-24	Retractable headlight switch	3-20
recommendation	9-3, IBC	Jump starting	6-3	Rust and corrosion	10-1
Exhaust gas warning	4-4	Key	2-3	Seats	2-3
Fog light switch	3-23			Seat belt	
Folding rear seat	5-19			adjusting	2-8
Freeing immobilized vehicle	6-1				
Fuel					
filler cap	5-19, 14-1				

maintenance	2-12	Towing	6-2
Service data		Trailer towing	2-13
bulbs	11-5	Turbocharger system	4-3
capacities	11-4	Turn signal switch	3-22
engine tune-up	11-4		
fuses	11-6	Vanity mirror	5-17
fusible links	11-6	Ventilation system	5-1
tightening torque	11-5	Ventilators	5-1
Spare tire	9-26	Viscosity, oil	9-5
Spark plugs		Voice warning	3-15
recommendation	4-11	Voltmeter	3-3
replacement	9-14		
Specifications		Warranty (See Warranty Booklet)	
dimensions	11-2	Warning chime	3-14
engine	11-3	Warning lights	
weights	11-3	brake	3-13
wheels and tires	11-3	charge (alternator)	3-13
Speedometer	3-2	coolant level	3-14
Spot light	5-18	door	3-14
Starting the engine	4-4	exhaust gas sensor	3-13
Steering wheel play	9-18	fuel	3-13
Stereo tape deck	5-11	oil pressure	3-12
Stopping distance	12-2	refrigerant	5-5
Sun visors	5-17	seat belt	3-14
		Washer fluid level	9-11, IBC
Tachometer	3-2	Wheel	
T-bar roof	5-22	care	9-29
Temperature gauge	3-4	changing	9-29
Theft warning system	3-16	Wiper and washer switch	
Tilting steering wheel	5-20	rear window	3-18
Tips on driving	4-11	windshield	3-18
Tips on starting	4-6	Wiper blades	9-16
Tire			
care	9-23		
changing	9-24		
inflation pressure	9-22, 14-1		
repair	9-23		
rotation	9-24		
Tonneau cover	5-21		

AMH00733



The first step in getting the best car for you is getting the best information.

FREE RECOMMENDATION

Customer's Name		Address	

Fill out and return to:

The first step in getting the best car for you is getting the best information.



Gas Station Information

FUEL FILLER CAP

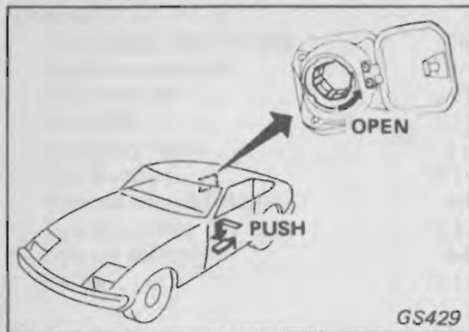

Do not forget to replace the filler cap after refilling.

FUEL RECOMMENDATION

	Gasoline	Gasoline octane number (Minimum)	
		AKI (Anti-Knock Index) number	Research octane number
		(R + M)/2	RON
All models	Unleaded	87	91

Tank capacity:

19 US gal (15-7/8 Imp gal, 72 liters)

The fuel filler opening is designed for use with an unleaded fuel nozzle [nozzle diameter less than 0.94 in (21.3 mm)] only.

AMH00734

HOOD RELEASE

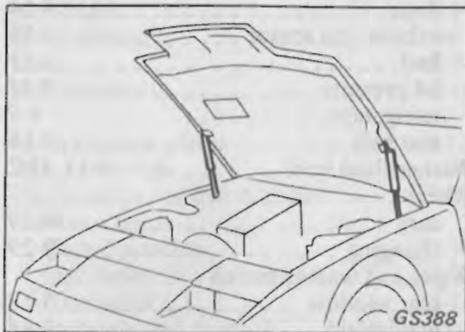
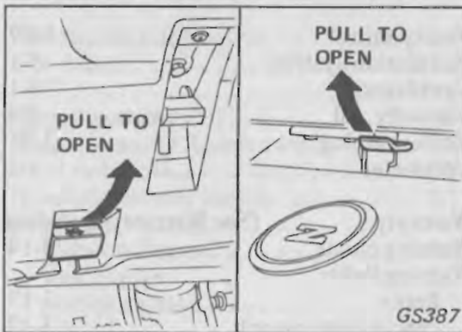

Pull the hood release handle located below the instrument panel to release the hood safety latch. Raise the hood by hand.

Further details and precautions are described in "Do-It-Yourself".

RECOMMENDED TIRE INFLATION PRESSURE

➤ Tire pressure should be checked when tires are COLD.

See the tire placard affixed to the inside of the center console box lid.



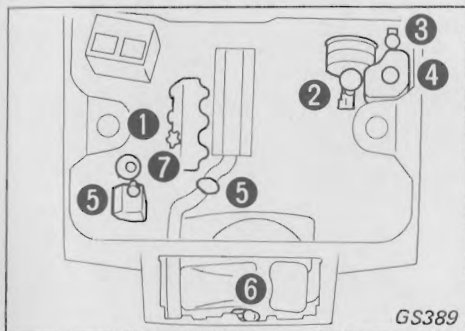

GS389

ENGINE OIL ①

The engine oil dipstick is located on the left side of the cylinder block.

The best time to check the oil level is at operating temperature several minutes after the engine has been turned off. Maintain oil level between "H" and "L" marks on dipstick.

Capacity at oil change

with filter: 4-1/4 US qt
(3-1/2 Imp qt,
4.0 liters)

without filter: 3-7/8 US qt
(3-1/8 Imp qt,
3.6 liters)

ENGINE OIL RECOMMENDATION

Use only recommended engine oil according to API classification SF (Energy Con-

serving Oils) for non-turbo engines and SF/CC or SF/CD for turbo engines.

Refer to "Engine oil and oil filter recommendation" in "Do-it-yourself".

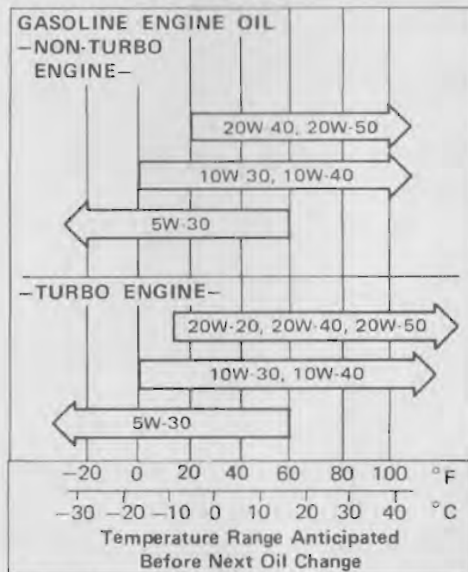

On models equipped with a turbocharger, use 10W - 30, 10W - 40, 20W - 20, 20W - 40 or 20W - 50 except under extremely cold conditions. Use 5W - 30 only under extremely cold conditions.

BRAKE ② AND CLUTCH ③ FLUID

Check brake and clutch reservoir fluid level. Use only recommended fluid DOT 3.

WARNING:

Adding the wrong type brake fluid or allowing the braking system to become contaminated can damage the system and affect the vehicle's stopping capability.

WINDSHIELD WASHER FLUID ④ / HEADLIGHT WASHER FLUID ⑥

Check reservoir fluid level. Always use NISSAN windshield washer liquid or equivalent.

ENGINE COOLANT ⑤

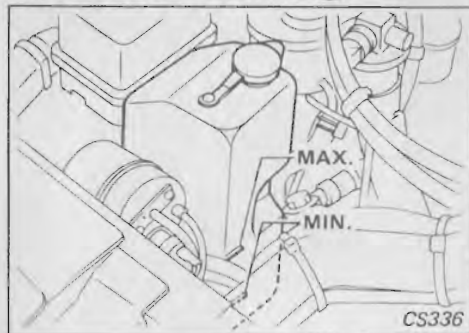

CS336

Check engine coolant level when system is cool. Coolant level should be maintained between Max. and Min. lines on reservoir.

POWER STEERING FLUID ⑦

Check power steering reservoir fluid level. Use only recommended fluid Type DEXRON.

AMH00735

'84 Z31-D



This Owner's Manual has been provided to introduce you to your new Nissan. A separate Warranty Booklet contains information concerning your new vehicle warranty.

BUT DID YOU KNOW ?

Thousands of Nissan owners are learning even more about the technical side of their new automobiles by purchasing Factory Service Manuals.



For information on how you may order your individual vehicle manual, see "Ordering Instructions" in this Owner's Manual.