



US005778181A

**United States Patent** [19]  
**Hidary et al.**

[11] **Patent Number:** **5,778,181**  
[45] **Date of Patent:** **Jul. 7, 1998**

[54] **ENHANCED VIDEO PROGRAMMING SYSTEM AND METHOD FOR INCORPORATING AND DISPLAYING RETRIEVED INTEGRATED INTERNET INFORMATION SEGMENTS**

5,481,542	1/1996	Logston et al.	348/7
5,534,913	7/1996	Majeti et al.	348/7
5,572,442	11/1996	Schulhof et al.	364/514 C
5,589,892	12/1996	Knee et al.	348/731
5,612,730	3/1997	Lewis	348/8

[75] Inventors: **Jack D. Hidary**, New York; **Craig Ullman**, Brooklyn, both of N.Y.

*Primary Examiner*—Parshotam S. Lall  
*Assistant Examiner*—Viet Vu  
*Attorney, Agent, or Firm*—Dorsey & Whitney LLP

[73] Assignee: **ACTV, Inc.**, New York, N.Y.

[21] Appl. No.: **615,143**

[57] **ABSTRACT**

[22] Filed: **Mar. 14, 1996**

A system for integrating video programming with the vast information resources of the Internet. A computer based system receives a video program with embedded uniform resource locators (URLs). The URLs, the effective addresses of locations or Web sites on the Internet, are interpreted by the system and direct the system to the Web site locations to retrieve related Web pages. Upon receipt of the Web pages by the system, the Web pages are synchronized to the video content for display. The video program signal can be displayed on a video window on a conventional personal computer screen. The actual retrieved Web pages are time stamped to also be displayed, on another portion of the display screen, when predetermined related video content is displayed in the video window.

**Related U.S. Application Data**

[63] Continuation-in-part of Ser. No. 613,144, Mar. 8, 1996, abandoned.

[51] Int. Cl.<sup>6</sup> ..... **G06F 13/00**; H04N 5/50

[52] U.S. Cl. .... **395/200.48**; 395/200.49; 348/12

[58] Field of Search ..... 395/200.3, 200.48, 395/200.47, 327, 200.49; 348/7, 8, 10, 13, 564, 906, 461, 12; 455/3.1, 5.1, 6.1, 6.3

[56] **References Cited**

**U.S. PATENT DOCUMENTS**

5,014,125 5/1991 Pocock et al. .... 348/7

**23 Claims, 2 Drawing Sheets**

**SYSTEM DESIGN**

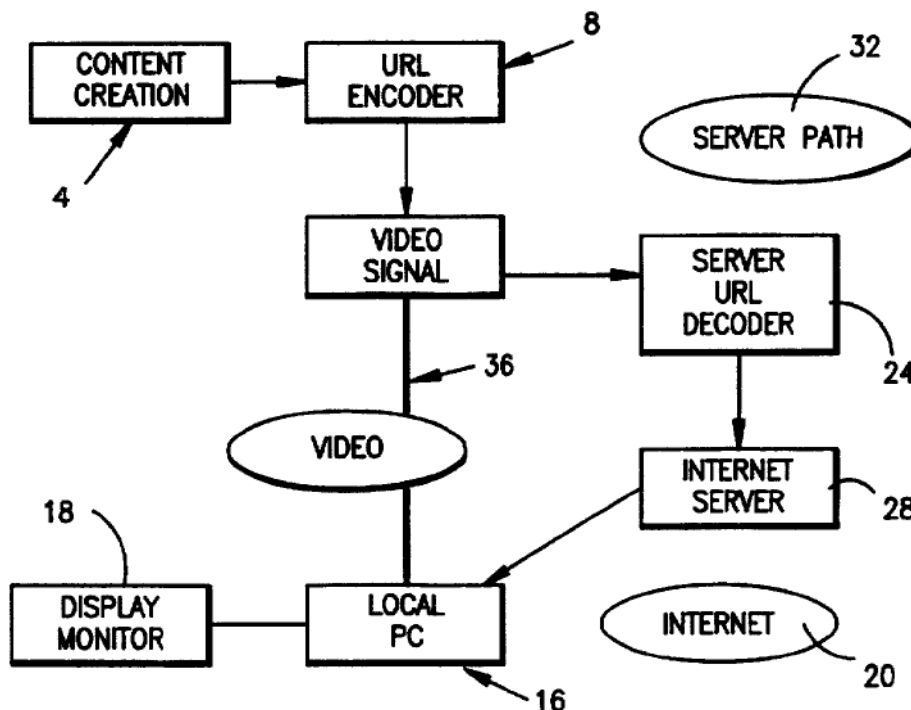

FIG. 1

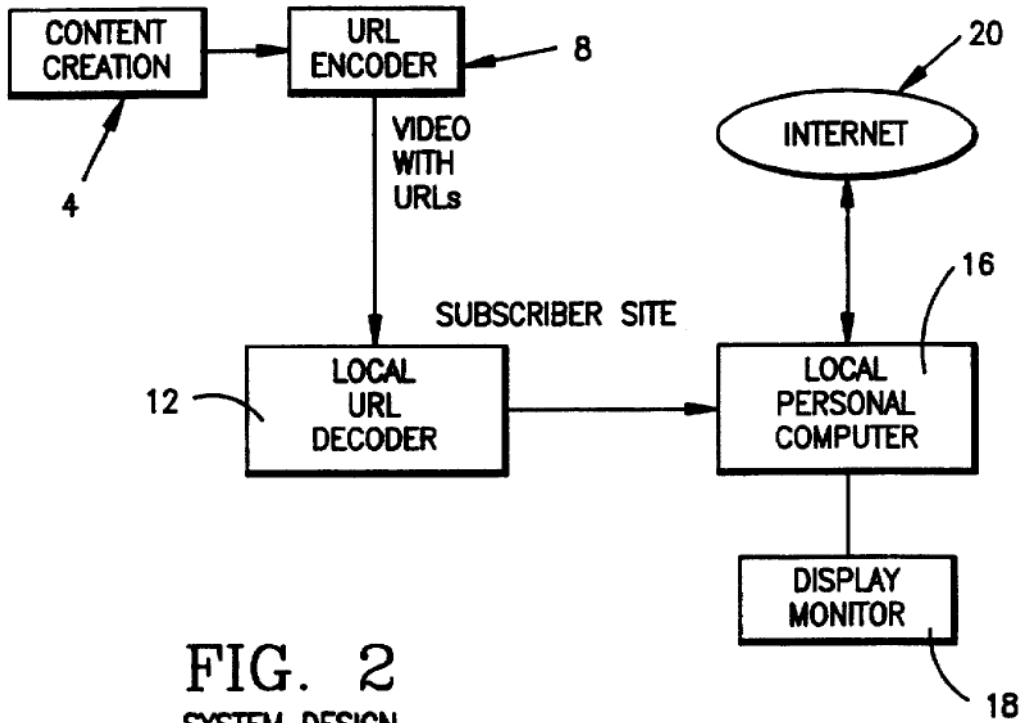
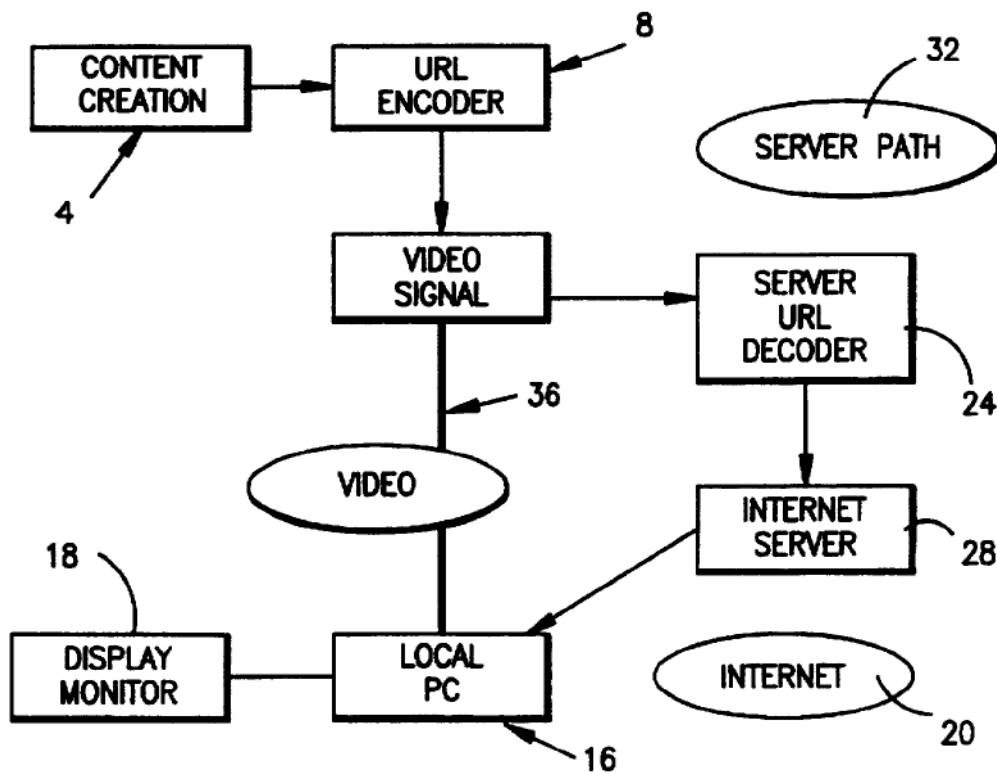
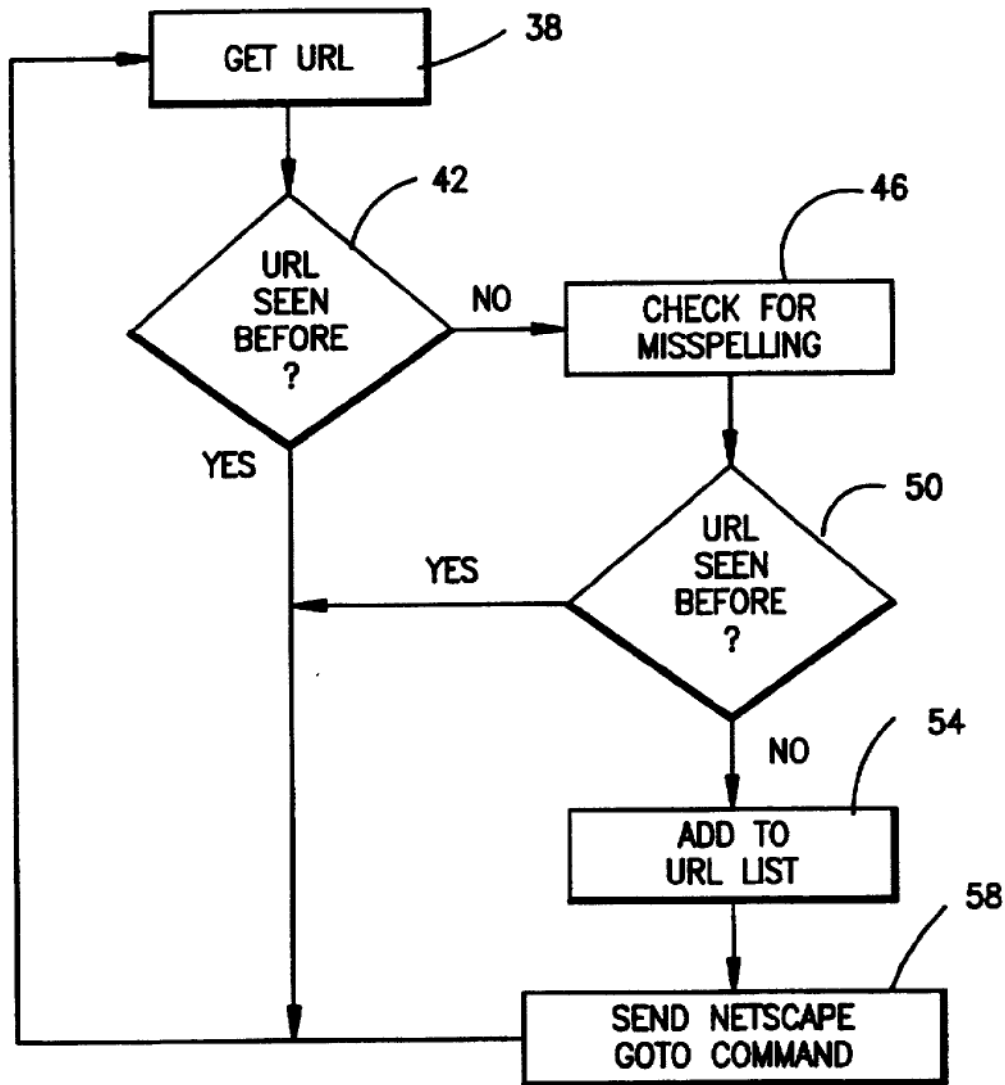

FIG. 2  
SYSTEM DESIGN





SOFTWARE DESIGN

FIG. 3

**ENHANCED VIDEO PROGRAMMING  
SYSTEM AND METHOD FOR  
INCORPORATING AND DISPLAYING  
RETRIEVED INTEGRATED INTERNET  
INFORMATION SEGMENTS**

This application is a continuation-in-part of application Ser. No. 08/613,144, filed Mar. 8, 1996, entitled "AN INTEGRATED INTERACTIVE VIDEO AND INTERNET SYSTEM" now abandoned.

**BACKGROUND OF THE INVENTION**

Today, the capabilities of computers to provide massive amounts of educational and entertainment information has exploded with the Internet. The Internet has the power to transform society through unprecedented levels of information flow between members. Currently, on-line systems offer a variety of different services to users, including news feeds, electronic databases (either searchable by the user directly on the on-line system, or downloadable to the users own computer), private message services, electronic newsletters, real time games for play by several users at the same time, and job placement services, to name a few. However, today, most on-line communications occur merely through text. This currently stands in great contrast to the audio/visual presentation of the alternative electronic medium, television. However, it is expected that as multi-media's incessant growth continues, audio/visual programs will proliferate and text will become less and less dominant in the on-line environment. Even though these programs will be introduced, the Internet, will remain essentially user unfriendly due to its very massiveness, organization, and randomness. Simply stated, there is no order or direction in the Internet. Specific pieces of information are many times hard to find, and harder yet, is the ability to put that piece of information into a meaningful context.

Television, on the other hand, has been criticized for being a passive medium—"chewing gum for the eyes," as Fred Allen once observed. Television has always been something you watched, not something you do. Many social critics believe that the passivity television depends on has seeped into our entire culture, turning a nation of citizens into a nation of viewers. While interactive television systems have increased the level of user interaction, and thus, provided greater learning and entertainment opportunities, vast information resources such as databases are inaccessible from such a medium.

What is needed is a means to close the gap between video programming and the information superhighway of the Internet. What is needed is a wider, richer experience integrating audio/visual and textual database elements into an organized unique interactive, educational, entertainment experience. Currently, the Internet is a repository of information on virtually any subject. However, what is needed is a mechanism for combining the user-friendly visual experience of television with the vast information resources of the Internet.

**SUMMARY OF THE INVENTION**

The system of the present invention combines broadcast television programming and/or video programming which appears on a VHS or Beta tape, CD-ROM, DVD or other medium, or video programming at a video server (hereinafter "video programming") with the massive Internet, creating a new and powerful educational and entertainment medium. The system allows consumers to receive

more information in a more efficient manner than either television or the Internet alone. Consumers not only can see a news report on television, but they can also read pertinent information about the report, as well as explore related information about the story. The program becomes the introduction to a particular subject, rather than the entire subject itself. The act of viewing a program has now become a more engaging, enriching experience.

The system can also create a more intimate relationship between the viewer and the program. The user might be solving problems or performing virtual experiments on the Internet site that a teacher is discussing in an educational television program. Similarly, the consumer might be solving problems that the fictional characters in a television program must solve. In both cases, the consumer is an active participant in the process, rather than a passive observer.

Instead of an undirected and unfocused exploration of Internet sites, by synching specific Internet pages to the video signal, the system puts the Internet in context. The television program producers now can decide what additional information to offer their audience. This material can now be seen in the context of the television program.

An additional advantage is that consumers don't have to search through the literally hundreds of millions of pages on the Internet to find appropriate material. The material has already been filtered by the program producers and delivered to the consumer automatically.

Another advantage of the system is that it changes the nature of advertising. Since additional information can be given to consumers automatically, advertising can now be more substantive, allowing customers to make more informed choices. Now, the act of purchasing a product seen on television can be streamlined—the consumer can be given the choice of buying the product instantly using the two-way capabilities of the system.

Another advantage of the current system is that in the alternative embodiment, the local user need not have a vertical blanking interval (VBI) reader to receive the uniform resource locators (URLs). Therefore, digital video can be used as the video source. The Intercast, by comparison, is an analog video product.

By marrying the appeal of television with the two-way data transfer capabilities of the Internet, the system creates a powerful new medium: Television producers and Internet site creators can enhance their content, advertisers can speak more directly to consumers, and consumers can gain a new level of interest and interactivity over a video-based medium.

Now, several media companies have joined to create a system for linking the Internet and television on the personal computer, called "Intercast." In this system, content will be provided simultaneously with the TV video signal. This system, however, requires that stripped down Web pages be sent in the vertical blanking interval (VBI) of the video signal, using up to three scan lines limiting effective bandwidth to approximately 28.8 kbps. This approach, however, requires specialized hardware to both insert the Web pages into the VBI and extract these codes at each PC since it takes up to three scan lines of the VBI. Thus, the complexity and cost of the PC is increased. Because the Web pages are transmitted with the video signal, the Intercast system is not a true "two-way" system, but merely a one-way "piggyback" system.

The system of the present invention, on the other hand, is a much more flexible, but less complex, system. First, the actual Web pages are not forced into the very limited

bandwidth of the vertical blanking interval (VBI). Instead, merely eight fields of line 21 of the VBI are used to deliver the relevant Internet Web page addresses to the PC. These addresses are called "uniform resource locators" (URLs). The system then directs the particular Web browser to retrieve the identified Web pages from the Internet. Upon receipt of the particular Web page(s), the system syncs the Web page(s) to the video signal, and at the appropriate times, presents the Web pages on one portion of the computer screen with the television video signal, shown in a window on another portion of the screen, and thus, provides the synergistic Internet and television experience. One of the advantages of the system of the present invention is that no specialized chip set need be produced and implemented into the standard PC. Thus, complexity is kept to a minimum.

Thus, it is an object of the present invention to provide order and direction to the Internet by using television signals to place, orient and control such information in a meaningful context.

It is an object of the present invention to create a more intimate relationship between the viewer and the program by enriching the learning experience through the provision of more indepth information.

#### DESCRIPTION OF THE DRAWINGS

FIG. 1 is a diagram of the system design, showing the receipt and decoding of video signals at the subscriber location using the method of the present invention.

FIG. 2 is a diagram showing an alternative system embodiment to achieve the integration of the Internet information with the video content by decoding the uniform resource locators at a server site and then transmitting the URLs to the subscriber stations via the Internet.

FIG. 3 is a flow diagram of the basic software design of the present invention.

#### PREFERRED EMBODIMENT

The system of the present invention combines the rich visual capabilities of television with the vast resources of the Internet. As shown in FIG. 1, the present invention is a computer based system for receiving a video program along with embedded uniform resource locators (URLs)—which direct the user's computer 16 to address locations, or Web sites, on the Internet 20 to retrieve related Web pages. These Web pages correspond to the video presentation. The particular video programming can be delivered in analog, digital or digitally compressed formats (e.g., MPEG2) via any transmission means, including satellite, cable, wire, or television broadcast.

The video programming is preferably created at a centralized location, i.e., content creation 4 as shown in FIG. 1, for distribution to subscribers in their homes, for example. Program creation is accomplished according to any conventional means known in the art. After a video program is created, uniform resource locators are embedded, preferably, into the vertical blank interval of the video programming by the URL encoder 8, shown in FIG. 1. In the preferred embodiment, the URLs are encoded onto eight fields of line 21 of the VBI. Line 21 is the line associated with close captioning, among other things. However, the URLs could also be embedded in other fields of the VBI, in the horizontal portion of the video, as part of the audio channel, or in any subcarrier to the video. Preferably, the URLs have associated time stamps which indicate to the subscriber stations when, during the video program, to display the particular Web pages addressed by the URLs.

The particular information in line 21 is not part of the visual part of the program, and thus, is not perceptible to the human eye, thereby making it ideal to send data information to the users. While the bandwidth capacity of line 21 is limited, because the system of the present invention transmits only the uniform resource locators (URLs), and not full Web pages, there is more than enough capacity. Furthermore, no additional hardware is necessary at the PCs 16 to implement the elements of the present invention. Thus, the present invention has the additional advantages of being very efficient and takes advantage of conventional hardware.

Once the video program is created, it can be transmitted to user sites over any transmission means, including broadcast, cable, satellite, or Internet, and may reside on video servers. Furthermore, the video program, with embedded URLs, can be encoded on a VHS or Beta tape, DVD or other medium.

Preferably, each receiver station comprises any Intel x86 machine (preferably a 486 processor, pentium processor, etc.), an Apple Computer, UNIX or any other type of standard computer workstation. The local PC 16 is preferably connected to either a cable and/or broadcast television connection or to a local VCR or other video source. At each subscriber site, the local personal computer 16 preferably receives the cable transmission by cable connection on the back of the personal computer 16. The video/audio program can then be processed for display on the computer screen using any conventional PC card capable of displaying NTSC signals on a computer monitor, such as a WinTV card. In addition to the cable connection, however, in the present invention there is also an Internet 20 connection created concurrently with the cable connection.

The Internet 20 connection can be via high-speed line, RF, conventional modem or by way of two-way cable carrying the video programming. The local PC 16 has internet access via any of the current ASCII software mechanisms. In the preferred embodiment, at each subscriber home, an associated local URL decoder 12 receives the cable video television program, as shown in FIG. 1. The local URL decoder 12 extracts the URLs, preferably embedded in the vertical blanking interval, with the use of any conventional VBI decoder device. The URL decoder 12 may be either a standalone unit or a card which is implemented into the personal computer 16.

In an alternative system shown in FIG. 2, the uniform resource locators (URLs) are encoded into the video in the same manner as described above. Again, the URLs are preferably encoded onto eight fields of line 21 of the VBI. However, the URL decoder 24 is located at the server site, as opposed to the subscriber location. When the decoder 24 receives the video program signal, it strips out the URL codes on line 21 of the VBI and delivers these codes independently to an Internet server 28. The URL code is then subsequently delivered over the Internet 20 to the user PC 16. Simultaneously, the video is broadcast over conventional broadcast or cable transmission means 36 to the user's personal computer 16.

#### System Operation

Once the URLs have reached the personal computer 16, system operation is the same for both of the embodiments diagramed in FIGS. 1 and 2.

In the preferred embodiment, a JAVA enabled browser as well as specialized software for performing part of the method of the present invention are installed on the computer. The JAVA enabled browser allows the computer 16 to

# Explore Litigation Insights

Docket Alarm provides insights to develop a more informed litigation strategy and the peace of mind of knowing you're on top of things.

## Real-Time Litigation Alerts



Keep your litigation team up-to-date with **real-time alerts** and advanced team management tools built for the enterprise, all while greatly reducing PACER spend.

Our comprehensive service means we can handle Federal, State, and Administrative courts across the country.

## Advanced Docket Research



With over 230 million records, Docket Alarm's cloud-native docket research platform finds what other services can't. Coverage includes Federal, State, plus PTAB, TTAB, ITC and NLRB decisions, all in one place.

Identify arguments that have been successful in the past with full text, pinpoint searching. Link to case law cited within any court document via Fastcase.

## Analytics At Your Fingertips



Learn what happened the last time a particular judge, opposing counsel or company faced cases similar to yours.

Advanced out-of-the-box PTAB and TTAB analytics are always at your fingertips.

## API

Docket Alarm offers a powerful API (application programming interface) to developers that want to integrate case filings into their apps.

## LAW FIRMS

Build custom dashboards for your attorneys and clients with live data direct from the court.

Automate many repetitive legal tasks like conflict checks, document management, and marketing.

## FINANCIAL INSTITUTIONS

Litigation and bankruptcy checks for companies and debtors.

## E-DISCOVERY AND LEGAL VENDORS

Sync your system to PACER to automate legal marketing.