

Microsoft®
Windows® 98
ResourceKit

Microsoft® Press

PUBLISHED BY
Microsoft Press
A Division of Microsoft Corporation
One Microsoft Way
Redmond, Washington 98052-6399

Copyright © 1998 by Microsoft Corporation

Material appearing in chapters 17 and 18 is based on material originally created as:

Novell-Supplied NetWare Clients: The Benefits,

Copyright © 1997, 1998 Novell, Inc. All rights reserved.

Used, reproduced, and distributed with permission from Novell, Inc.

All rights reserved. No part of the contents of this book may be reproduced or transmitted in any form or by any means without the written permission of the publisher.

Library of Congress Cataloging-in-Publication Data
Microsoft Windows 98 Resource Kit / Microsoft Corporation.

p. cm.

Includes index.

ISBN 1-57231-644-6

1. Microsoft Windows (Computer file) 2. Operating systems

(Computers) I. Microsoft Corporation.

QA76.76.063M5244 1998

005.4'469--dc21

98-2768

CIP

Printed and bound in the United States of America.

1 2 3 4 5 6 7 8 9 WCWC 3 2 1 0 9 8

Distributed in Canada by ITP Nelson, a division of Thomson Canada Limited.

A CIP catalogue record for this book is available from the British Library.

Microsoft Press books are available through booksellers and distributors worldwide. For further information about international editions, contact your local Microsoft Corporation office or contact Microsoft Press International directly at fax (425) 936-7329. Visit our Web site at mspress.microsoft.com.

ActiveX, BackOffice, Direct3D, DirectDraw, DirectInput, DirectPlay, DirectSound, DirectX, DoubleSpace, DriveSpace, FrontPage, Microsoft, Microsoft Press, MS-DOS, Natural, Picture It!, PowerPoint, Visual Basic, Visual C++, WebBot, Win32, Windows, and Windows NT are registered trademarks and ActiveMovie, Authenticode, DirectAnimation, DirectMusic, DirectShow, JScript, MSN, NetMeeting, NetShow, OpenType, and Outlook are trademarks of Microsoft Corporation. Novell and NetWare are registered trademarks of Novell, Inc. in the United States and other countries.

Other product and company names mentioned herein may be the trademarks of their respective owners.

The example companies, organizations, products, people, and events depicted herein are fictitious. No association with any real company, organization, product, person, or event is intended or should be inferred.

Acquisitions Editors: Casey D. Doyle, David Clark, Anne Hamilton

Project Editor: Maureen Williams Zimmerman

Security

9

This chapter presents an overview of security features provided in Microsoft Windows 98. It describes their use, together with security features of Internet Explorer version 4.0, in a networking environment. It is intended for system administrators and others who have authority to set security levels for network clients, and for those who need secure communication over the Internet.

| | | |
|------------------------|--------------------------------------|-----|
| In This Chapter | Overview of Security Features | 356 |
| | Security Planning Checklist | 360 |
| | Network Security | 361 |
| | Passwords | 370 |
| | Internet Explorer Security | 376 |
| | Security Features in Outlook Express | 383 |
| | Firewalls | 388 |
| | Distributed Component Object Model | 390 |
| | Troubleshooting Security | 393 |

- See Also**
- For information about file and printer sharing services and user-level or share-level security, see Chapter 18, “Logon, Browsing, and Resource Sharing.”
 - For information about editing system policies, see Chapter 8, “System Policies.”
 - For information about security for Internet Explorer, see Chapter 20, “Internet Access and Tools.”
 - For information about Distributed Component Object Model (DCOM), see Chapter 29, “Windows 98 Network Architecture” and Chapter 25, “Application Support.”

Overview of Security Features

Computer security refers to the protection of all components—hardware, software, and stored data—of a computer or a group of computers from damage, theft, or unauthorized use. A computer security plan that is well thought out, implemented, and monitored makes authorized computer use easy and unauthorized use or accidental damage difficult or impossible.

Personal computing depends increasingly on computers connected through networks, and more often through the Internet and intranets. You can use Windows 98 security to prevent unauthorized access to shared resources on computers in a network. The security features built into Windows 98 are described briefly in this section, and in more detail later in the chapter.

Logon Security

Windows 98 allows users to log on fully. In a networking environment, you can set your system up so that when a name and password pair have been validated against the security authority of a network server, the Windows 98 user interface is displayed.

Logon Password

A user can log on to all networks and Windows 98 at the same time. If a user's password for Windows 98 or for another network is the same as the password for the primary logon client, Windows 98 automatically logs the user on to Windows 98 and all networks using that password.

Note A unified password prompt does not enhance security, but eases logging on to the system. As the system administrator, you can require additional passwords for a more secure system.

For more information about the logon prompt, see "Using the Windows 98 Logon Password" later in this chapter. Once users log on to their machines, they have the option to cache their passwords. These passwords are cached in a file with a .pwl extension. The file name is the same as the user's name. See "Password Caching" later in this chapter.

Network Validation

With system policies, you can prevent users from logging on to Windows 98 if their Windows NT or Novell NetWare network logon is not validated. This causes the network logon dialog to appear before, or instead of, the Windows 98 logon prompt. Also, the user list may not be network wide, but specific to a server, and may be different for different servers.

For more information about logon security, see "Network Security" later in this chapter. For more information about system policies, see "Using System Policies to Enforce Password Security" later in this chapter, and Chapter 8, "System Policies."

Shared-Resource Security

When a computer is running Windows 98 with file and printer sharing services, other users can connect to shared printers, volumes, directories, and CD-ROM drives on that computer. To protect these shared resources, Windows 98 provides user-level and share-level security.

User-Level Security

With user-level security, a user's request to access a shared resource is passed through to a security provider, such as a Windows NT or NetWare server. The security provider grants or denies the request by checking the requestor's user name and password against a network-wide or server-wide stored list. User-level security does not require file and printer sharing services. These accounts must be created on the machine providing user-level authentication, such as a Windows NT or NetWare server. Windows 98 cannot act as an authentication server for user-level security.

This type of security allows fine-grained control over per-user access and allows individual accountability. The disadvantages are that you must create a user account for each user you want to grant access to, and you must grant that user the access.

Share-Level Security

With share-level security, users assign passwords to their shared resources. Any user who can provide the correct password is permitted to access the shared resource. The password is stored and checked by the computer where the resource resides. Share-level security requires file and printer sharing services.

Note Any subfolders of the shared folder, if they are also shared, must be set with the same level of security as the parent folder.

The advantage of this type of security paradigm is that it allows granting access to a broad range of people with very little effort. However, it is not as secure as user-level security, because the password is widely distributed and there is no notion of personal accountability.

Note You cannot use share-level security on NetWare networks, because the File and Printer Sharing for NetWare Networks utility does not support passwords. You can limit access, however, by defining a resource as read-only.

Password Controls

In addition to setting up passwords for security, Windows 98 also provides password caching, Password List Editor, and system policies.

Password Caching

Like unified logon, password caching provides a convenient and secure way to access protected resources. The first time a user connects to the resources and saves the password, Windows 98 caches the password in a PWL file. Whenever the user logs on again, the logon password unlocks the PWL file and the resource passwords it contains, and the user then has free access to those resources. If password caching is disabled, users must type the password each time they connect to a password-protected resource.

Password List Editor

Password List Editor lets you view resources on a password list. It also lets a user view or edit his or her own password file (PWL). You may then delete a password (you cannot view the actual password) so that it can be replaced.

System Policies

System policies let you enforce a password policy with some or all of these restrictions:

- Disable password caching.
- Require an alphanumeric Windows 98 logon password.
- Require a minimum Windows 98 logon password length.

You can also define system policies that prevent users from enabling peer resource sharing services and that enforce other security techniques, such as preventing users from configuring system components.

For more information, see "Using System Policies to Enforce Password Security" later in this chapter, and Chapter 8, "System Policies."

Internet and Intranet Security

The Internet is an effective way to communicate and share information with others, but with its use comes a greater need for security. The following security features make it easier for you to protect your computer and your privacy when using the Internet.

Internet Explorer

Internet Explorer 4.0 has new security options that let you configure a security level to a specific Web site according to how much you trust the content of that Web site. Four security zones are set up in Internet Explorer 4.0. They are:

- An Internet zone that by default contains all Internet sites.
- A Trusted sites zone to which you can assign Web sites you trust.
- A Restricted sites zone to which you can assign Web sites you do not trust.
- A Local intranet zone for computers connected to a local area network.

Outlook Express

Outlook Express includes tools to protect you from fraud, ensure your privacy, and prevent unauthorized access to your computer. These tools enable you to send and receive secure e-mail messages and to control potentially harmful e-mail messages through security zones.

Distributed Component Object Model

A distributed application consists of multiple processes that cooperate to accomplish a single task. The Distributed Component Object Model (DCOM) can be used to integrate distributed applications in a network, thus allowing specified users to have access to certain processes.

Firewalls

A firewall enforces a boundary between networks. The boundary prevents unauthorized access of private networks by preventing the passage of packets between networks.

Security Planning Checklist

You need to determine the type of exposure or risk you potentially have, and develop a security policy that reflects this level of risk. On the basis of that analysis, choose products, network technology, and business practices for the installation, integration, and management of your system.

Before you integrate Windows 98 security into your network security model, consider the following issues:

What kind of logon security do you need? Do you allow users to log on to Windows 98 and the network with the same password? Do you want to require alphanumeric or minimum-length passwords for the Windows 98 logon password? Do you want to require that users be validated by the network security provider before being able to log on to Windows 98? For both Windows NT and NetWare networks, you can use system policies to require validation by a Windows NT or NetWare server before allowing access to Windows 98 and to specify other Windows 98 password restrictions.

What kind of resource protection do you need on Microsoft networks? If you enable peer resource sharing, you must decide how to protect those resources with share-level or user-level security. User-level security provides greater security because the network security provider must authenticate the user name and password before access to the resource is granted. Share-level security is not available for NetWare networks.

For more information about NetWare networks, see Chapter 17, "Windows 98 on Third-Party Networks."

What kinds of access rights will users have to resources protected by user-level security? You can specify the types of rights users or groups of users have to resources by setting Sharing properties for the shared resource (such as a folder or drive). For example, you can restrict other users to read-only access to files or give them read-access and write-access to files.

How do you want to enable user-level security? You can enable security in a setup script or in system policies. If you enable user-level security in either a setup script or Control Panel, remote administration is enabled by default for domain administrators on a Windows NT network and for supervisors on a NetWare network.

Should password caching be allowed? You can use system policies to disable password caching and thus require users to type a password each time they access a password-protected resource.

Should users be able to change Control Panel settings? You can use system policies to restrict users' ability to change the configuration of system components, their desktops, applications, or network connections in the Control Panel folder.

Does a particular hard disk need extra protection? Windows 98 security obstructs hacking over the network; but if a person has physical access to the computer, critical data could still be taken from the hard disk where it resides by using Safe Mode or a floppy disk to start the workstation. If specific data requires greater levels of security, you should store critical files on a secure server. If computers require greater levels of security, Windows NT Workstation is recommended, because it provides a means to protect resources on a hard disk based on a user's identity.

Are there applications that should not be run? You may need to restrict access to some applications while supplying access to other applications in your system. To implement this type of security, use system policies. You can also restrict access to parts of an application by using DCOM.

Do certain processes of an application need protection? If security is required for a distributed application—that is, one whose component processes are distributed over more than one computer in the network—use DCOM. DCOM provides the structure to share applications at the component level between a server and clients. The components can be shared over the Internet or an intranet. Using DCOM to set a security level for the application automatically applies that security level to each component, wherever located.

Should Internet or intranet access be limited? You may need to limit access to certain sites on the Internet and on your intranet. To implement this type of security, use Internet Explorer security features.

Network Security

Windows 98 allows users to log on fully. The first thing most users encounter after booting their Windows 98 systems is a logon dialog box, which varies depending on the type of network. Once the proper user name and password are validated against the security authority of the network server, the Windows 98 user interface is displayed.

System administrators can configure the Windows 98 system to allow entry into the operating system with no network access (this configuration is the default). As an alternative solution to this problem, system administrators can specify guest accounts that have limited network access.

The Windows 98 user logon should not be construed as a mechanism to fully secure personal computers. Because personal computers are still vulnerable to a floppy boot, all data stored on their disks is potentially available. The underlying file system in Windows 98 is the MS-DOS file allocation table (FAT) file system, which has no built-in encryption or other security mechanisms.

Network resources are secured under Windows 98 using the same security mechanisms employed by network servers on corporate networks. The user name and password in Windows 98 can be configured to be the same as those used by the network server. By doing this, the network manager can control network access, provide user-level security for access to shared resources on the local computer, control the various agents in Windows 98, and limit who has remote administration authority on this Windows 98 system. In this fashion, Windows 98 leverages the existing investment in network servers, management tools, utilities, and infrastructure. System administrators can manage user accounts centrally on the server, just as they always have. They can also use familiar tools for managing user accounts.

Implementing Network Security

Implementing security in a Windows 98 networking environment involves the following types of activity:

- Define user accounts on a network server or domain controller for user-level security. For more information, see the documentation for the software on the network security provider.
- Install file and printer sharing services, and then enable user-level or share-level security.
- Define access rights for resources protected by user-level security.
- Make the Windows 98 logon password and network logon password the same. Disable password caching if you do not want this feature. For more information, see “Using the Windows 98 Logon Password” and “Using the Windows 98 Password Cache” later in this chapter.
- Define system policies to restrict users’ ability to configure the system or shared resources, and to enforce password policies.
- Define Internet and intranet security zones. For more information, see “Setting Up Security Zones” later in this chapter.

Sharing Resources

Windows 98 provides share-level or, alternatively, user-level security for protecting shared resources on computers running Windows 98 (the share level requires file and printer sharing services).

Share-level security protects shared network resources on the computer running Windows 98 with individually assigned passwords. For example, you can assign a password to a folder or a locally attached printer. If other users want to access it, they need to type in the appropriate password. If you do not assign a password to a shared resource, every user with access to the network can access that resource.

User-level security protects shared network resources by requiring that a security provider authenticate a user's request to access resources. The security provider, such as a Windows NT domain controller or a NetWare server, grants access to the shared resource by verifying that the user name and password are the same as those on the user account list stored on the network security provider. Because the security provider maintains a network-wide list of user accounts and passwords, each computer running Windows 98 does not have to store a list of accounts.

Note For Microsoft networks, the security provider must be a Windows NT domain or workstation. For NetWare networks, it must be either a NetWare 4.x server running bindery emulation or a NetWare 3.x server.

Figure 9.1 shows how user-level security works for Microsoft networks. The reference numbers are explained after the illustration.

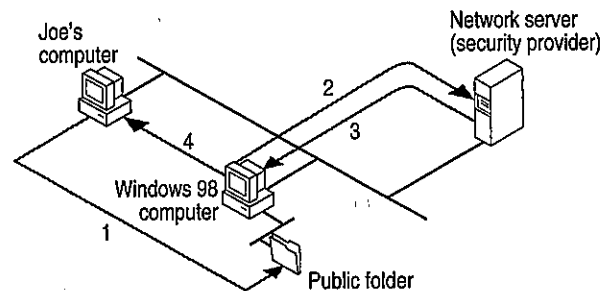

Figure 9.1 User-level security

1. Joe's computer is running Windows 98. Joe enters a password to access a shared resource protected by user-level security.
2. The Windows 98 computer passes a request to the server (security provider) to authenticate Joe's identity.
3. The security provider sends a verification to the computer if Joe's name and password combination are valid.
4. Windows 98 grants access to the shared resource according to rights assigned to Joe on the Sharing property sheet for that resource.

Joe's password is stored on his computer's PWL file to be used for authentication when he accesses that resource again. He will not be prompted for the password again during that session. When he logs off, the computer will erase his password from the file.

Setting Up Security for Shared Resources

Before a user can share a resource on a computer running Windows 98, the computer must be configured for share-level or user-level security, and file and printer sharing services must be installed by using the Network option in Control Panel. Configuring share-level or user-level security is described briefly in the following sections, and in Chapter 18, "Logon, Browsing, and Resource Sharing."

Note Share-level security is not available on NetWare networks.

► **To set up share-level security**

1. Install File and Printer Sharing for Microsoft Networks, as described in the "Installing Peer Resource Sharing" section of Chapter 18, "Logon, Browsing, and Resource Sharing."
2. On the computer that hosts the resource to be shared, in Control Panel, double-click Network, and then click the **Access Control** tab.
3. Click **Share-level access control**, and then click **OK**.

► **To set up user-level security on a Microsoft network**

1. Install File and Printer Sharing for Microsoft Networks, as described in the "Installing Peer Resource Sharing" section of Chapter 18, "Logon, Browsing, and Resource Sharing."
2. In Control Panel, double-click Network, and then click the **Access Control** tab.
3. Click **User-level access control**.
4. In the **User-level access control** box, type the name of the Windows NT domain or Windows NT workstation where the user accounts reside.
5. Click **OK**.

► **To set up user-level security on a NetWare network**

1. Install File and Printer Sharing for NetWare Networks, as described in the "Installing Peer Resource Sharing" section of Chapter 18, "Logon, Browsing, and Resource Sharing."
2. In Control Panel, double-click Network, and then click the **Access Control** tab.

3. Click **User-level access control**.
4. In the **User-level access control** box, type the name of the NetWare server.
5. Click **OK**.

For information about specifying values for security in custom setup scripts, see Appendix D, "Msbatch.inf Parameters for Setup Scripts." For information about using System Policy Editor to set user-level security and other security options, see Chapter 8, "System Policies."

Using Share-Level Security

You can restrict access to resources such as a shared folder or a printer by either defining it as read-only or assigning a password to it.

- ▶ **To share a folder or printer with share-level security**
 1. In Windows Explorer, right-click the folder or printer to be shared, and then click **Properties**.
 2. In the **Properties** menu, click the **Sharing** tab.
 3. Click **Shared As**, and type the resource's share name.

The shared resource name will be the computer name plus the share name. For example, in the following screen shot, if the computer name is mycomputer, this shared resource is \\mycomputer\mydocuments.

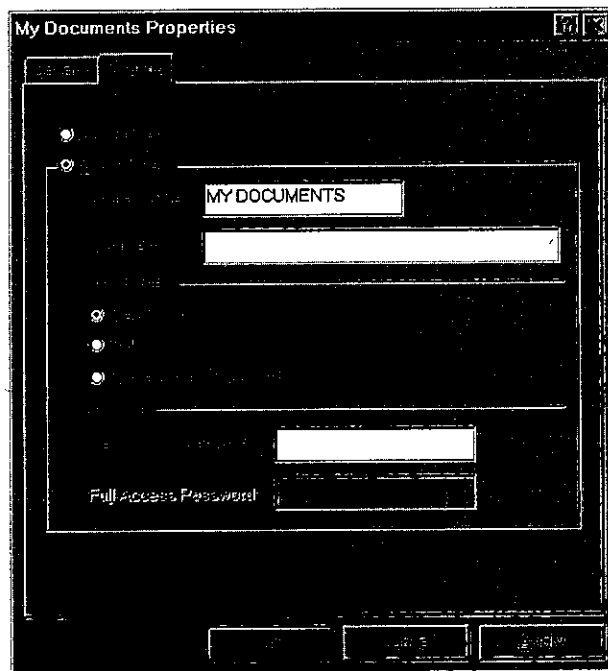

4. Specify whether you want users to have read-only or full access to this resource.

Note There is no read-only share-level access for a printer or remote administration.

5. Type the password for the specified access, and click **OK**.

Tip You can share a folder but hide it from the Network Neighborhood browsing list by adding a dollar sign (\$) to the end of its share name (for example, PRIVATE\$).

Using User-Level Security

Windows 98 uses the logon process to provide user-level security for a variety of services beyond network resource access, including the following services that are remotely accessible:

- File and printer sharing.
- Dial-up network access gateway control.
- Backup.
- Network and system management.

Pass-through security is implemented in Windows 98 as the mechanism to enable user-level security. *Pass-through* literally means that Windows 98 passes authentication requests through to a Windows NT or NetWare server. Windows 98 does not implement its own unique user-level security mechanism but instead uses the services of an existing server on the network.

Enabling pass-through security is a two-step process. First, user-level security must be enabled using the Control Panel. Second, the device must be shared, and users with access privileges must be specified. Right-clicking the drive C icon in My Computer and selecting **Properties** from the Shortcut menu displays a property sheet that shows which shares already exist and which users have access. It also allows new devices to be shared and new users to be added to specific shares. The Windows NT server or the NetWare bindery supplies the user names listed in this property sheet.

For more information about file and printer sharing, see Chapter 18, "Logon, Browsing, and Resource Sharing."

The Remote Administration function of a Windows 98 personal computer specifies the users or groups who have authority to manage the Windows 98 system, including the following:

- Dial-up network access gateway control.
- Backup.
- Remote access to the registry.
- Remote NetWatcher access.
- Remote system performance monitoring.

Remote Administration is controlled through the Passwords option in Control Panel. For more information about Remote Administration, see Chapter 23, "System and Remote Administration Tools."

For each network resource governed by user-level security, there is a list of users and groups that can access that resource.

► **To share a resource with user-level security**

1. In Windows Explorer or My Computer, right-click the icon for the resource to be shared, and then click **Properties**.
2. In the **Properties** menu, click the **Sharing** tab.
3. Click **Add**.
4. In the **Add Users** dialog box, click a user or group, and then assign access rights as described in the following paragraphs.

Assign, for each user, a set of rights for the resource. The kinds of rights that you assign depend on the kind of resource you are securing:

- For shared directories, you can let a user have read-only access, full access, or custom access. Within custom access, you can grant the user any or all of the following rights: read, write, create, list, delete, change file attributes, and change access rights.
- For shared printers, a user either has the right to access the printer or not.
- For remote administration, a user either has the right to be an administrator or not as defined in the Passwords option in Control Panel.

Permissions are enforced for a resource as follows:

- If the user has explicit rights to the resource, those rights are enforced.
- If the user does not have explicit rights to the resource, the permissions are determined by taking all of the rights of each group to which the user belongs.
- If none of the groups to which the user belongs has any rights to that resource, the user is not granted access to the resource.

When you do not explicitly assign access rights to a file or folder, Windows 98 uses implied rights. *Implied rights* are those assigned to the nearest parent folder of a file or folder. If none of the parent folders (up to and including the root directory of the drive) have explicit rights, no access is allowed.

Note Implied rights are displayed automatically on the property sheet for the shared file or folder.

Specifying Folder Access Rights in User-Level Security

Access rights specify what a user can do in a folder protected by user-level security. The access rights you define for a folder apply to all of its subfolders. You cannot, however, assign access rights to individual files in Windows 98. (Both Windows NT and NetWare let you assign access rights to files.)

Note Any subfolders of the shared folder, if they are also shared, must be set with the same level of security as the parent folder.

For each folder, you can assign read-only, full, or custom access. Custom access lets you further specify exactly what each user or group can do in the folder, as specified in Table 9.1.

Table 9.1 Custom access options

| File operation | Required permissions |
|----------------------------------|---|
| Read from a closed file | Read files |
| See a file name | List files |
| Search a folder for files | List files |
| Write to a closed file | Write, create, delete, change file attributes |
| Run an executable file | Read, list files |
| Create and write to a file | Create files |
| Copy files from a folder | Read, list files |
| Copy files to a folder | Write, create, list files |
| Make a new folder | Create files |
| Delete a file | Delete files |
| Remove a folder | Delete files |
| Change folder or file attributes | Change file attributes |
| Rename a file or folder | Change file attributes |
| Change access rights | Change access control |

► **To define custom access**

1. Open the **Add Users** dialog box in a shared resource's properties (described in the procedure, "To share a resource with user-level security" earlier in this chapter).
2. In the **Add Users** dialog box, click a user or group, click **Custom**, and then click **OK**.
3. In the **Add Users** dialog box, click a user or group from the **Name** list, and then click **Custom**.
4. In the **Change Access Rights** dialog box, click the type of rights the user or group of users may have in the folder, and then click **OK**.
5. To remove a user or group of users, click that user or group, and then click **Remove**.
6. To edit the access rights for a user or group of users, click that user or group, and then click **Edit**.

Managing User Lists

Windows 98 user-level security depends on a list of accounts and groups located on a security provider. You cannot add or remove users and groups from the security provider list by using Windows 98 tools. However, you can do this by running User Manager for a Windows NT domain, SYSCON for NetWare 3.x, and NETADMIN for NetWare 4.x in a NetWare bindery environment. You can use these tools on a computer running Windows 98. These tools are provided by the respective vendors and not by Windows 98. Under Windows 98, you specify what rights users have to specific resources on the local computer as described in "Using Share-Level Security" earlier in this chapter. For more information about changing a user's access rights, see "Specifying Folder Access Rights in User-Level Security" earlier in this chapter.

Note Although Windows NT networks allow multiple domains, a computer running Windows 98 can specify only one domain for user-level security. However, you can set permissions for users or groups from any domain in the Sharing properties for the shared resource, as long as the two domains have a proper trust relationship. Also, rights may include user accounts from different trusted domains. To use a trust relationship to access multiple domains, you should consult the *Microsoft Windows NT Server 4.0 Concepts and Planning Guide*, part of the Windows NT Server documentation set.

Managing Security for Windows 98 in NetWare Bindery Environments

NetWare 3.x servers store all the information about users, groups, passwords, and rights in a database stored on the server called the *bindery*. NetWare 4.x servers can appear to have a bindery through bindery emulation, a feature that is enabled by default. There is a separate bindery for each NetWare server. Windows 98 can use the bindery of only one NetWare server as the security provider. It is common for a company to have one or more NetWare servers per department, where users log on to the server for their department. This scenario can pose a problem when the bindery differs from one NetWare server to another. For example, Sue and Bob log on to the Sales server, and Fred logs on to the R&D server. Because Sue is running Windows 98 and can specify only one server for pass-through validation, she specifies Sales (the server she uses for logon). She can now grant access to shared resources on her computer to Bob but cannot grant access to Fred.

The only way to solve this problem is to include all user accounts for all servers on one NetWare server. This server should be specified as the security provider for every computer running Windows 98 with File and Printer Sharing for NetWare Networks.

Note Windows 98 supports only bindery emulation to obtain user lists on NetWare 4.x servers. It does not support user lists obtained with NetWare Name Service (NNS) or other add-on services for that purpose.

Passwords

A good password policy helps users protect their passwords from other individuals. This helps to reduce the probability of someone logging on with another user's password and gaining unauthorized access to data.

The following guidelines should help you create a basic security policy:

- Tell users not to write down their passwords.
- Tell users not to use obvious passwords, such as their names, their spouses' names, their children's names, and so on.
- Do not distribute user accounts and passwords in the same communication. For example, if you are sending a new user's account name and password in writing, send the user name and the password at different times.

You can use the following Windows NT and NetWare security features to enhance Windows 98 security:

Enforce a reasonable minimum password length. This policy increases the number of permutations needed to guess someone's password randomly or programmatically. Additionally, you can enforce an alphanumeric password combination to achieve the same security.

Enforce maximum and minimum password age. This policy forces the user to change the password, preventing someone else from discovering it as a result of the password being in use for a long time. A minimum password age prevents a user from immediately reverting to a previous password after a change.

Enforce password uniqueness and maintain password history. This policy prevents users from toggling between their favorite passwords. You can specify the number of unique passwords that a user must have before that user can use a previously used password.

For more information about using Windows NT and NetWare security features, see the documentation for those products, or see the *Microsoft Windows NT Server Networking Guide* in the *Windows NT Server Resource Kit* (for Windows NT Server version 4.0) (ISBN 1-57231-343-9).

Using the Windows 98 Logon Password

With Windows 98, users can log on to all networks and Windows 98 at the same time. The first time a user starts Windows 98, logon dialog boxes appear for Windows 98 and for each network client on that computer. This is useful for you as a network administrator, because you can use existing user accounts on a network security provider to validate access to the network for users running Windows 98. For more information, see Chapter 18, "Logon, Browsing, and Resource Sharing."

If a user's password for Windows 98 or for another network is the same as the password for the primary logon client, Windows 98 logs the user on to Windows 98, and then the network automatically uses that password. When a user logs on to other networks with different passwords and chooses to save them, the passwords are stored in the password list file. The Windows 98 password unlocks this file. Thereafter, Windows 98 will use the passwords stored in the password list file to log a user on to other networks, so that no additional passwords need to be typed. This single logon provides a solution to the problem of password proliferation.

The Passwords option in Control Panel provides a way to synchronize logon passwords for different networks. This allows users to use the password for whatever logon dialog box appears first (the primary network logon client or Windows 98 logon) for logging on to all other network clients.

► **To change a password for a network resource to be the same as the Windows 98 logon password**

1. In Control Panel, double-click Passwords, and then click **Change Windows Password**.
2. In the **Change Windows Password** dialog box, select the other passwords you would like to change to use the same password as the Windows 98 password, and then click **OK**.

To appear in this list, the related software must include a function that lets its password be changed.

3. In the second **Change Windows Password** dialog box, type the current (old) Windows 98 password, type a new password, and then, in the **Confirm new password** box, type the new password again. Click **OK**.

Note The Windows Screen Saver passwords option appears here only if the Windows screen saver has been turned on and the password-protected option has been selected.

You can maintain separate passwords for a network resource and require users to type a password each time they access it.

► **To change a password for a network resource**

1. In Control Panel, double-click Passwords, and then click **Change Other Passwords**.
2. In the **Select Password** dialog box, select the password you want to change, and then click **Change**.
3. In the **Change Password** dialog box, type the current (old) network password, type a new password, and then, in the **Confirm new password** box, type the new password again. Click **OK**.

You must now type the new password to access the resource.

Note You can also use the Passwords option to change individual passwords to other network resources to be different from the Windows 98 logon password.

Using Windows 98 with NetWare Passwords

To log on to a NetWare network, you must type the name of the preferred server on which the related user account is stored. After the user name and password are validated by the network server, you can use resources shared on that server. If you are not validated, you will be prompted to enter a password whenever connecting to a NetWare server during this work session.

The first time you attempt to connect to a NetWare server other than the preferred server, Windows 98 searches for an appropriate user name and password in the PWL file. If no matching set of credentials is found, Windows 98 tries to log on using the Windows 98 password. If this fails, Windows 98 displays a NetWare logon prompt for you to enter a valid user name and password, which can then be stored in the PWL file.

- ▶ **To avoid use of automatic NetWare logon**
 - Use system policies to enable the policy named **Disable Automatic NetWare Login**.

- ▶ **To change your password on a NetWare server**

1. At the command prompt, use the **net use** command to connect to the NetWare server's SYS volume. For example, for a server name NWSVR2, you would type:

```
net use * \\nwsvr2\sys
```

2. At the command prompt, change to the drive for the NetWare server, and then make the Public folder the current folder. For example, if the drive is mapped to drive N, type:

```
n:
```

Then type:

```
cd \public
```

Note If you want to change your password on more than one server, connect to all affected servers before running the **setpass** command. Setpass is a utility provided by Novell and is not part of Windows 98.

3. At the command prompt, type **setpass**.

If the server on which you want to change your password is different from the one on the current drive, type **setpass** and the name of the server.

For example, to change your password on the server named NWSERVE1, type:

```
setpass nwserve1
```

4. When you are prompted, type your old password, and then type and confirm the new password.
5. If you are connected to other NetWare servers that also use your old password, these servers are listed, and you are asked if you want to change your password on these servers also.

Using the Windows 98 Password Cache

Keeping track of multiple passwords can be a problem for users. Often, they either forget the passwords or write them down and post lists of passwords near their computers. When this happens, the security policy is no longer doing the job it was meant to do—to allow access to those who should have it and to deny access to those who should not.

Windows 98 solves this problem by storing passwords for resources in a password list file (PWL). This file stores passwords for the following network resources:

- Resources on a computer running Windows 98 that are protected by share-level security.
- Password-protected applications that have been specifically written to the password-caching application programming interface (API).
- Windows NT computers that do not participate in a domain.
- A Windows NT logon password that is not the Primary Network Logon.
- NetWare servers.

The password list file is stored in the Windows folder on the local computer by using an encryption algorithm. An unencrypted password is never sent across the network.

Caution If you delete PWL files, you will lose all previously stored passwords. You will need to retype each password.

Password caching is enabled by default when you install Windows 98. When you access a password-protected resource for the first time, make sure the **Save this password in your password list** option is selected (it should be selected by default) to save the password to the password list file.

Note If, during log on, you click **Cancel** to bypass the logon screen, the cache will not be opened, and you will be prompted for a password each time you attempt to use a protected resource.

You can disable password caching by using System Policy Editor, which is shipped on the Windows 98 compact disc but not automatically installed onto your system during Setup. Use the Add/Remove Programs option in Control Panel to install System Policy Editor.

► **To install System Policy Editor**

1. In Control Panel, double-click Add/Remove Programs, click the **Windows Setup** tab, and then click **Have Disk**.
2. In the **Install From Disk** dialog box, click **Browse** and specify the Tools\Admin\Poedit folder on the Windows 98 compact disc.
3. Click **OK**, and then click **OK** again in response to the dialog boxes.
4. In the **Have Disk** dialog box, click **System Policy Editor**, and then click **Install**.

► **To disable password caching by using system policies**

1. On the **Start** menu, click **Run**.
2. Type **poedit**, and then click **OK**.
3. In System Policy Editor, double-click the Local Computer icon.
4. In the Local Computer Properties, click **Network**.
5. Click **Passwords**.
6. Click the policy named **Disable Password Caching**.

For more information, see Chapter 8, "System Policies."

Note If you have any share-level security servers and you disable password caching and are running Client for Microsoft Networks, you should not use the **Quick Logon** feature in the Network option in Control Panel.

Using Password List Editor

If password caching is enabled, Windows 98 caches passwords in the password list file when you connect to a password-protected network resource. Password List Editor (Pwledit) lets you view the resources listed in a user's password list (PWL) file. It does not let you view the actual passwords, but lets you remove specific password entries if problems are encountered using a cached password.

Password List Editor works only if the password list file is unlocked, that is, if the user is logged on. It can be used to view only the contents of the logged-on user's password list file, so you should run it on the user's computer.

Note Only users themselves can view or edit their own PWL files.

Password List Editor can be found in the Netadmin\Pwledit folder on the Windows 98 compact disc.

► **To install Password List Editor**

1. In Control Panel, double-click Add/Remove Programs, click the **Windows Setup** tab, and then click **Have Disk**.
2. In the **Install From Disk** dialog box, click **Browse**.
3. Type the path name to Netadmin\Pwledit\Pwledit.inf, and then click **OK**.
4. In the **Have Disk** dialog box, click **Password List Editor**, and then click **Install**.

► **To run Password List Editor**

- On the **Start** menu, click **Run**. Type **pwledit**, and then click **OK**.

Using System Policies to Enforce Password Security

You can use system policies to increase security by requiring users to follow specific password guidelines. Using system policies, you can enforce password policies.

For information about restricting settings with system policies, see Chapter 8, "System Policies."

Internet Explorer Security

Internet Explorer 4.0 adds several security features to Windows 98, including support for security zones, Secure Socket Layer (SSL) versions 2.0/3.0 and Private Communication Technology (PCT) version 1.0 protocols, client and server authentication, and the Platform for Internet Content Selection (PICS) rating system. These security features make it easier for you to protect your computer and your privacy while using the Internet.

Security zones. You can divide the Web into zones and have Internet Explorer 4.0 provide different levels of security depending on which zone you have assigned to a Web site.

When you install Windows 98, you configure the following Internet Explorer settings:

- Internet zone
- Trusted sites zone
- Restricted sites zone
- Local intranet zone

A fifth zone, My Computer, is also created, but it is not configurable through the security options.

This system lets the administrator divide the Web content a browser can visit into groups, each of which can have a security level associated with it. The Web content can be anything from a Hypertext Markup Language (HTML) file to a graphic, an ActiveX control, a Java applet, or an executable file.

Authenticode technology. An Authenticode certificate identifies who published a piece of software and verifies that it has not been tampered with.

Certificate management. System administrators can control which Java applets, ActiveX controls, and other software can be run on their intranets, based on who published the software.

Capabilities-based Java security (sandboxing). The Internet Explorer 4.0 security model for Java makes it easy for you to control how Java applets interact with your computer system. You can decide what capabilities and levels of access to your computer or system you want to give Java applets. You can offer full access to applets from trusted sources while restricting applets from unknown sources to safe “sandboxes” where they cannot harm files.

Privacy protection. Internet Explorer 4.0 supports all standard Internet security protocols to ensure private communication over the Web. Internet Explorer prompts you before user names or passwords are sent to Web sites not designated as trusted. For trusted sites, you can choose not to be prompted before personal information is transmitted. Outlook Express—the Internet mail and news component of Internet Explorer 4.0—lets you encrypt messages and ensures that no one can falsely assume your identity on the Internet.

The following sections explain how to configure these settings.

Setting Up Security Zones

Internet Explorer 4.0 has security options that let you configure a security level to a specific Web site according to how much you trust the content of that Web site. Five predefined security zones, four of which have configurable security settings, are set up in Internet Explorer 4.0:

- Internet zone that by default contains all Internet sites.
- Trusted sites zone to which you can assign Web sites you trust.
- Restricted sites zone to which you can assign Web sites you do not trust.
- Local intranet zone for computers connected to a local area network.
- Local machine called My Computer, unsecured, providing full access to all aspects of the machine, not configurable.

Note Because security works differently in Internet Explorer 4.0, any existing Internet Explorer 3.0 settings are not preserved.

Using the **Internet Properties** dialog box in the Internet option in Control Panel, you can set the security options you want for Internet, Trusted sites, Restricted sites, and Local intranet, and then add or remove sites from the zones depending on your level of trust in each site.

In corporate environments, administrators can set up zones for users and can add or remove authentication certificates of software publishers that they do or do not trust so that users do not have to make security decisions while they are using the Internet.

For each security zone, you can choose a High, Medium, Low, or Custom security setting. Use the High setting for sites in a zone of untrustworthiness and Low in a trusted zone. The Custom option gives advanced users and administrators even more control over all security options, including the following:

- Access to files, ActiveX controls, and scripts.
- The level of capabilities given to Java applets.
- Whether sites must be identified with SSL authentication.

► **To set up security zones**

1. In Control Panel, double-click Internet.
2. Click the **Security** tab.
3. Configure the settings according to your security needs.

Setting Up the Internet Zone

By default, the Internet zone is set to the Medium security level. If you are concerned about security problems as users browse the Internet, change this setting to High. When this level is set to High, some Web pages may not be allowed to perform certain operations that can potentially compromise security.

For more advanced and detailed security control, use the Custom settings to configure each individual security setting for the zone.

► **To set up custom settings for the Internet zone**

1. In the **Security** tab, select **Custom**, and then click **Settings**.
2. Configure the settings according to your security needs.

Adding Sites to the Trusted and Restricted Zones

You can classify Web sites into two categories, according to how much you trust their contents:

- Trusted sites zone
- Restricted sites zone

By default, the Trusted sites zone is set to the Low security level. When you add a site to the Trusted sites zone, the site is allowed to perform more operations, and Internet Explorer will ask you to make fewer security decisions when you access the site. Add a site to this zone only if you trust all of its content never to do anything that may harm your computer. For the Trusted sites zone, it is strongly recommended that you use the HTTPS protocol so that you can securely connect to the site.

By default, the Restricted sites zone is set to the High security level. When you add a site to the Restricted sites zone, the site is allowed to perform only minimal, very safe operations. Add sites that you do not trust to this zone.

► **To add sites to the Trusted sites zone or Restricted sites zone**

1. In the **Security** tab, select either the **Trusted sites zone** or **Restricted sites zone** in the Zone list.
2. Click **Add Sites**, select the desired sites for that zone, and then click **OK**.

Setting Up the Local Intranet Zone

To be secure, the Local intranet zone must be set up in accordance with the proxy server and firewall configuration. All sites in the zone should be “inside the firewall,” and proxy servers should be configured so that they do not allow an external Domain Name System (DNS) to be resolved in this zone.

By default, the Local intranet zone consists of local domain names and those set in proxy override in the **Connection** tab. Make sure that these settings are indeed secure for the installation; if they are not, adjust them as needed. You can check that the Local intranet zone is configured correctly by browsing various intranet and Internet pages and checking that the correct zone is shown in the status bar.

After you have checked that the Local intranet zone is secure, you can change the zone's security level to Low to allow a wider range of operations and make the Web pages more functional. You can also adjust individual security settings in the **Security Settings** dialog box as explained in "Setting Up the Internet Zone" earlier in this section.

If parts of your intranet are not secure or do not meet your security standards, you can exclude them from the Intranet zone by adding them to the Restricted sites zone.

The Local intranet zone is designed to be configured using the *Microsoft Internet Explorer Administration Kit*; however, you can also use the **Security** tab in the **Internet Properties** dialog box.

Summary of Authenticode Technology

When users download signed code to their computers, *Authenticode* verifies both its publisher and its integrity (that it has not been tampered with since the author published it). No software can be guaranteed to be 100 percent safe under all circumstances, but Authenticode uses public key technology to sign objects digitally and help you make informed decisions about blocking the execution of certain code. Authenticode works with all common types of downloadable code, including Java applets, ActiveX controls, and plug-ins.

Authenticode checks to see that a piece of software is digitally signed during the valid lifetime of the publisher's certificate.

Authenticode can also automatically check to make sure a software publisher's certificate has not been revoked. Publishers can have their certificates revoked if they abuse their code-signing agreement by, for example, creating malicious code that harms users' computers.

Summary of Certificate Management

Authentication certificates are a key tool in providing Internet security. Certificate management eases the administration of network security. The certificates, which are assigned to software publishers who meet defined levels of integrity and security in their code, give users a way to identify the origin of a piece of software on the Internet. This identification mechanism forms the basis of Authenticode. Certificate Management lets system administrators control which Java applets and ActiveX controls are allowed to run on their networks based on who published the applets or controls.

Example**Certificate Management**

You can let users open and run all internally created controls, but keep all controls that originate from outside your corporate firewall from loading and running on company computers.

Site certificates verify that you are really connected to the Web sites that you believe you are connected to. Viewing information may not present a security risk, but sending information can. Security certificates are issued to particular organizations for specific periods of time. Before you send information, certificates are sent from the secure Web sites to Internet Explorer 4.0. These certificates provide certain information about security at those sites. Internet Explorer 4.0 verifies that the Internet address stored in the certificate is valid and that the current date precedes the expiration date.

Note Site Certificates are active only for Uniform Resource Locators (URLs) using HTTPS. Communication to and from Web sites using HTTPS are kept private through encryption when this mode is active.

► **To see the site certificates stored in Internet Explorer 4.0**

1. Start Internet Explorer.
2. Click the **View** menu, and then click **Internet Options**.
3. Click the **Content** tab, and then click **Authorities**.

By default, the **Certificate Authorities** dialog box contains a list of authorities that are allowed to issue certificates to sites.

If you are connected to a site with a certificate, a lock icon appears on the bottom right corner of the browser window.



Summary of Java Security (Sandboxing)

Support for *sandboxing*, the Java security model, was built into Internet Explorer 3.0 and has been enriched in Internet Explorer 4.0. Running a Java applet in a sandbox prevents it from accessing a computer or network resource and also greatly restricts what it can do. Internet Explorer lets you control access of applets to users' resources, such as their hard disks and network connections. It presents users with a range of security options, such as allowing a Java applet to access a specific amount of hard disk space on a client computer.

Summary of Privacy Protection

The following list describes the kinds of privacy protection built into Internet Explorer 4.0.

Secure channel services. Support for Secure Socket Layer (SSL) versions 2.0/3.0 and Private Communication Technology (PCT) version 1.0 ensures that personal or business communications using the Internet or an intranet are private. The SSL and PCT protocols create a secure channel so that no one can eavesdrop on communications. With secure communications guaranteed, users can buy consumer goods, reserve plane tickets, or conduct personal banking on the Internet.

Transport Layer Security. Transport Layer Security (TLS) is a new secure channel protocol under development by the Internet Engineering Task Force. TLS builds on existing protocols to create an improved Internet secure channel protocol.

Personal Information Exchange. The Personal Information Exchange (PFX) is a set of public key-based security technologies that is part of the Microsoft Internet security framework. PFX supports such Internet standards as X.509 and PKCS#12 certificate formats. Microsoft has submitted PFX for consideration as a new Public Key Cryptography Standard (PKCS).

Cookie privacy. Some Web sites use *cookie technology* to store information on client computers. These cookies are usually used to provide Web site personalization features. With Internet Explorer 4.0, you can choose whether or not to store a cookie.

Tip You can decline cookies from a site by selecting **Prompt before accepting cookies** on the **Advanced** tab in the **Internet Options** dialog box of the Internet Explorer **View** menu.

SOCKS firewall support. Many corporations provide their employees with access to the Internet through firewalls that protect the corporation from unwanted access. SOCKS is a standard protocol for traversing firewalls in a secure and controlled manner. Internet Explorer 4.0 is compatible with firewalls that use the SOCKS protocol.

Windows NT Server challenge/response. Corporations can take advantage of the Microsoft Windows NT LAN Manager challenge/response authentication that might already be in use on their Windows NT Server network. Users enjoy increased password protection and security while still able to use their existing Internet information servers.

CryptoAPI version 2.0. CryptoAPI provides the underlying security services for secure channels and code signing. Through CryptoAPI, developers can easily integrate strong cryptography into their applications. Cryptographic Service Provider (CSP) modules interface with CryptoAPI and perform functions, including key generation and exchange, data encryption and decryption, hashing, digital signatures, and signature verification. CryptoAPI is included as a core component of Windows 98 and Windows 95. Internet Explorer 4.0 automatically provides this support for earlier versions of Windows.

Microsoft Wallet. Microsoft Wallet supports securely storing important and private information, such as credit cards, electronic driver's licenses, ATM cards, and electronic cash. No application or person can view this information without a user's permission. In addition, a user decides where to store the information (on a computer, smart card, or floppy disk). Users have to enter password or account information only once and do not have to remember many different passwords. Users have complete control over who can see or use this information. Wallet allows information to be securely transferred to any computer and used with any application through the use of PFX technology. Designed for the future, Wallet supports additional payment methods (such as Internet cash) as well as other credentials and confidential information.

PICS standards for Internet content. Parents want the assurance that children can be blocked from visiting sites that display inappropriate information. Corporations have similar concerns, wanting to block the use of sites that offer no business value to their customers. Microsoft has been working closely with the Platform for Internet Content Selection (PICS) committee to help define standards for rating Internet content.

Forget your password? With Internet Explorer 4.0, you do not have to type your user name and password every time you want to access a subscription Web service. Instead, Internet Explorer 4.0 functions as your virtual wallet, flashing your personal certificate to Web servers that want to verify your identity. It works the other way, too. You can also store certificates of Web servers in Internet Explorer 4.0. This means you can verify the identity of any Web merchant or other Web server before you purchase goods or communicate with them.

Security Features in Outlook Express

As the use of e-mail and electronic commerce becomes more widely adopted, the amount of confidential information being exchanged over the Internet is growing rapidly. As a result, there is a need to make e-mail messages secure and private. In addition, with the growing popularity of ActiveX controls, scripts, and Java applets, there is an increased chance that the HTML content you receive in an e-mail message could damage or compromise files on your computer.

Outlook Express includes tools to protect you from fraud, ensure your privacy, and prevent unauthorized access to your computer. These tools enable you to send and receive secure e-mail messages and to control potentially harmful e-mail messages through security zones.

Using Security Zones for Outlook Express

Outlook Express enables you to choose which Internet Explorer security zone your incoming e-mail messages are in—either the Internet zone or the Restricted sites zone. Which zone you decide to select depends on how concerned you are about active content (e.g., ActiveX controls, scripts, and Java applets) weighed against the freedom to run that content on your computer. In addition, for each security zone, you can choose a High, Medium, Low, or Custom security level setting.

For more information about security zones, see “Setting Up Security Zones” earlier in this chapter.

Caution Changing the settings for the Internet zone or Restricted sites zone will also change this setting for Internet Explorer and vice versa.

- ▶ **To change the security zones settings for Outlook Express**
 1. In Outlook Express, click the **Tools** menu.
 2. Click **Options**, and then click the **Security** tab.
 3. Configure the settings according to your security needs.

Using Digital IDs

To use secure e-mail in Outlook Express, you need a digital ID. Digital IDs (also called certificates) provide a means for proving your identity on the Internet, much as a driver’s license or other ID cards identify you.

Digital IDs let you sign your e-mail messages, so that the intended recipients can make sure that the message actually came from you and has not been tampered with. Also, a digital ID allows other people to send you encrypted messages.

For more information, see Outlook Express Help.

Getting a Digital ID

You obtain your digital ID from a certifying authority, an organization responsible for issuing digital IDs and continuously verifying that digital IDs are still valid.

Using Your Digital ID

Before you can send signed e-mail messages, you must associate your digital ID with the e-mail account you want to use it with.

- ▶ **To associate your digital ID with an e-mail account**
 1. In Outlook Express, click the **Tools** menu, and then click **Accounts**.
 2. Select the account you want to use your ID with, click **Properties**, and then click the **Security** tab.
 3. Select **Use a digital ID when sending secure messages from**.
 4. Click **Digital ID**, and then select the digital ID you want to associate with this account.

Note Only the digital IDs with the same e-mail address as the e-mail address for the account will be shown.

Backing Up Your Digital ID

Part of your digital ID is an irreplaceable private key stored on your computer. If the private key is lost, you will no longer be able to send signed e-mail messages or read encrypted e-mail messages with that digital ID. You are strongly encouraged to make a backup of your digital ID in case the files containing it are damaged or made otherwise unreadable.

- ▶ **To back up your digital ID**
 1. In Internet Explorer, click the **View** menu, and then click **Internet Options**.
 2. Click the **Content** tab, and then click **Edit Profile**.
 3. Click the **Digital IDs** tab.
 4. The **Import** and **Export** buttons let you manage your digital IDs. Use **Export** to back up your digital ID.

Sending Secure E-mail Messages

Now that you have a digital ID, you can send secure e-mail messages. Secure e-mail messages in Outlook Express protects your Internet communications through both digital signatures and encryption. Using digital signatures, you can sign your e-mail message with a unique ID that assures the person receiving the message that you are the true sender of the message and that it was not tampered with in transit. Encrypting e-mail messages that you send can ensure that no one except the intended recipient can read the contents of the message while it is in transit.

Because Outlook Express uses the Secure/Multipurpose Internet Mail Extensions (S/MIME) standard, other people can read secure e-mail messages that you compose, using programs that support this technology. Likewise, you can read messages composed by other people by using e-mail programs that support S/MIME technology.

Sending and Receiving Signed E-mail Messages

Signed e-mail messages let recipients verify your identity. To send signed e-mail messages, you must have a digital ID of your own.

► **To digitally sign an e-mail message**

1. In Outlook Express, click the **Tools** menu.
2. Click **Options**, and then click the **Security** tab.
3. Select **Digitally sign all outgoing messages**.

–Or–

Use the **Digitally sign message** button on the message toolbar.

Signed e-mail messages from others lets you verify the authenticity of a message—that the message is from the supposed sender and the message has not been tampered with during transit. Signed e-mail messages are designated with special signed e-mail icons. Any problems with signed e-mail messages that you receive (described in Outlook Express security warnings) could indicate that the message has been tampered with or was not from the supposed sender.

Sending and Receiving Encrypted E-mail Messages

Encrypting an e-mail message prevents other people from reading it when it is in transit. To encrypt an e-mail message, you need the digital ID of the person you are sending the e-mail message to. The digital ID must be part of the person's entry in the Address Book.

► **To send encrypted e-mail messages**

1. In Outlook Express, click the **Tools** menu.
2. Click **Options**, and then click the **Security** tab.
3. Select **Encrypt contents and attachments for all outgoing messages**.

–Or–

Use the **Encrypt message** button on the message toolbar.

When you receive an encrypted e-mail message, you can be reasonably confident that the message has not been read by anyone else. Outlook Express automatically decrypts e-mail messages, provided that you have the correct digital ID installed on your computer.

Sending and Receiving Digital IDs

For others to be able to send you encrypted e-mail messages, they need your digital ID. To send it to them, simply send them a digitally signed e-mail message, and Outlook Express will automatically include your digital ID.

To send others encrypted e-mail messages, you need their digital ID. Outlook Express lets you retrieve digital IDs via directory services.

► **To find a digital ID**

1. In Outlook Express, click the **Edit** menu, and then click **Find People**.
2. Select a directory service that supports digital IDs (for example, the VeriSign directory service).
3. Enter the recipient's name or e-mail address in the appropriate search field, and then click **Find Now**.
4. Select a listing from the results pane, and then click **Add to Address Book**.

Changing Trust Status on Digital IDs

When you add someone's digital ID to your Address Book, it has a trust status associated with it that indicates whether you trust the individual, group, or corporation to whom the digital ID was issued. If a digital ID owner warns you that he or she suspects that the digital ID's private key has been compromised, you may want to change the trust status to "Explicitly Distrust."

► **To change the trust status of a digital ID**

1. In the Address Book, double-click the name of the contact.
2. Click the **Digital IDs** tab, select the digital ID whose trust level you want to change, and then click **Properties**.
3. Click the **Trust** tab, and then select an option in the Edit Trust area.

For more information, see Outlook Express Help.

Firewalls

An Internet firewall lets you take advantage of the services offered on the Internet, while limiting exposure to attack. A *firewall* may consist of a collection of hardware and software components that collectively provide a protected channel between networks with differing security. Potential paths to the private network are limited by configuring the firewall to accept only packets from Internet Protocol (IP) addresses and/or ports of the Transmission Control Protocol/Internet Protocol (TCP/IP) that have been designated by the system administrator.

For more information, see Chapter 20, "Internet Access and Tools."

Understanding Proxy Servers

The most critical component of your firewall is your proxy server. A *proxy server* listens to the computers on your internal network. When a client application makes a request, a proxy server responds by translating the request and passing it to the Internet. When a computer on the Internet responds, the proxy server passes that response back to the client application on the computer that made the request.

Proxy servers make a firewall safely permeable to users behind the secured entrance, while closing entryways in the private network to potential attacks. The proxy server must act as both a server and client. It serves proxy clients when accepting approved requests for external servers, and requests services from those servers on behalf of its clients. Proxy servers are commonly used by administrators of corporate networks connected to the Internet and by Internet Service Providers (ISPs).

Microsoft Proxy Server provides an easy, secure, and cost-effective way to bring Internet access to every desktop in an organization. Microsoft Proxy Server routes requests and responses between the Internet and client computers, acting as a liaison between them. In addition to routing requests, Microsoft Proxy Server provides a cache of frequently requested Internet sites, blocks access to specified sites, and provides secure access between your internal network and the Internet. It also offers firewall features.

Configuring Proxy Servers

Access to Web sites secured by Windows NT Challenge and Response requires that firewalls and proxy servers be configured to permit passage of Windows NT Challenge and Response.

If you want to use a proxy server or firewall to protect your local area network (LAN) from being accessed by others on the Internet, carry out the following steps, which set up your computer to gain access to the Internet through a firewall.

► **To set up a LAN proxy server or firewall**

1. Run the Internet Connection Wizard.

Click **Start**, point to **Programs**, point to **Internet Explorer**, and then click **Connection Wizard**.

2. Configure your computer to connect to the Internet by using TCP/IP on your LAN.
3. When you are prompted for the gateway address, type an address only if your organization uses gateways for routing information over the network.

Note The gateway computer is not the same as the proxy server or firewall computer that protects your LAN from the Internet, so do not type your proxy server or firewall address here.

4. In Control Panel, double-click Internet, and then click the **Connection** tab.
5. In the Proxy server area, select the **Access the Internet using a proxy server** check box.
6. Click **Advanced**.
7. In the first text box, type the Hypertext Transfer Protocol (HTTP) server address for the computer you want to use as the proxy server. In the second text box, type the port number. An example of a proxy server and port number is **http://myproxy.mycompany.com:80**.

In this example, you would type **http://myproxy.mycompany.com** in the first text box, and **80** in the second text box.

You can use a different proxy for different types of addresses. However, if you want to use the same proxy for all types of addresses, make sure you select the **Use the same proxy server for all protocols** check box.

8. In the Exceptions area, click the text box, and then type the names of the computers, domains, and ports on the Internet that, when accessed, will not go through the proxy server. Separate each item you type with a semicolon (;). Local addresses are defined as those in which the server name does not have a period (.) in it.

For example:

- `http://internalweb/` is a local address.
- `http://www.microsoft.com/` is not a local address.

For Help on these items, click the ? in the title bar, and then click the item.

9. When you have finished changing settings, click **OK**.
10. Click **OK** to close the Internet properties in Control Panel.

If you are running Internet Explorer, restart your computer so that the new proxy settings can take effect.

Note If you are setting up Internet Explorer with a SOCKS proxy server, you must set it up separately from other proxy information (for example, HTTP, FTP, or Gopher). In most cases, this means that all other proxy fields should be left blank and the SOCKS field should contain the address of your SOCKS proxy server. The only exception is when you are using a SOCKS proxy server and a different proxy (for example, HTTP) on the same connection.

For more information about proxy servers and firewalls, see *Microsoft Proxy Servers Installation and Administration Guide*.

Distributed Component Object Model

The Component Object Model (COM) defines how components and their clients interact. The *Distributed Component Object Model* (DCOM) extends the COM infrastructure that underlies ActiveX, transparently and naturally adding support for reliable, secure, and efficient communication between ActiveX controls, scripts, and Java applets residing on different machines on a LAN, a wide area network (WAN), or the Internet. With DCOM, applications can be distributed across locations that make the most sense to your customer and to the application.

Because DCOM is a seamless evolution of COM, you can leverage your existing investment in all ActiveX applications, components, tools, and knowledge to move into standards-based distributed computing. As you do so, DCOM handles the low-level details of network protocols. DCOM enables component applications to operate across the Internet, because it works natively with such Internet technologies as TCP/IP and Java. It provides the "object glue" that allows business applications to work across the Web.

Figure 9.2 shows the overall DCOM architecture. The COM run-time provides object-oriented services to clients and components and uses the remote procedure call (RPC) and the security provider to generate standard network packets that conform to the DCOM wire protocol standard. COM provides sophisticated mechanisms for the marshaling and unmarshaling of method parameters that build on the RPC infrastructure defined as part of the distributed computing environment (DCE) standard. DCE RPC defines a standard data representation for all relevant data types, the Network Data Representation (NDR).

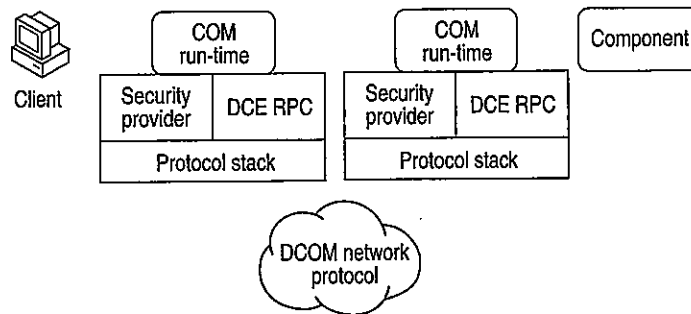

Figure 9.2 Overall DCOM architecture

A distributed application consists of multiple processes that cooperate to accomplish a single task. A distributed application can accommodate different clients with different capabilities by running components on the client side when possible and running them on the server side when necessary. A distributed application is also much more scalable than its monolithic counterparts, and easier to administer and deploy.

Designing a distributed application poses several challenges to the developer. One of the most difficult design issues is security: Who can access which objects? Which operations is an object allowed to perform? How can administrators manage secure access to objects? How secure does the content of a message need to be as it travels over the network?

Mechanisms to deal with security-related design issues have been built into DCOM from the ground up. DCOM provides an extensible and customizable security framework upon which developers can build when designing applications.

Different platforms use different security providers, and many platforms even support multiple security providers for different usage scenarios or for interoperability with other platforms. DCOM and RPC are built in such a way that they can simultaneously accommodate multiple security providers.

Common to all these security providers is their providing a means of identifying a security principal (typically a user account), a means of authenticating a security principal (typically through a password or private key), and a central authority that manages security principals and their keys. If a client wants to access a secured resource, it passes its security identity and some form of authenticating data to the resource, and then the resource asks the security provider to authenticate the client. Security providers typically use low-level custom protocols to interact with clients and protected resources.

Configuring Applications to Use DCOM

The DCOM Configuration tool can be used to configure 32-bit COM and DCOM applications.

- ▶ **To run the DCOM Configuration tool**
 - Click **Start**, click **Run**, and then type **dcomcnfg**.

Note Before you can use an application with DCOM, you must use DCOM Configuration to set application properties, such as security and location.

Distributed Applications for the Internet or an Intranet

You can use DCOM to integrate client/server applications across multiple computers. DCOM provides the infrastructure that enables client/server applications to share components over the Internet or intranet.

- ▶ **To set default permissions for all DCOM applications**
 1. Run **dcomcnfg** to open the DCOM Configuration tool.
 2. Click the **Default Security** tab.
 3. Click **Edit Default** for Default Access Permissions.
 4. If necessary, click **Add** to add other user accounts to the **Name** box.
- ▶ **To set permissions for a DCOM application**
 1. Run **dcomcnfg** to open the DCOM Configuration tool.
 2. Click the application you want to configure, and then click **Properties**.
 3. Click the **Security** tab.
 4. Select **Use Custom Access Permissions** for launch, access, or configuration, and then click **Edit**.
 5. If necessary, click **Add** to add other user or group accounts to the **Name** box.

- ▶ **To grant permissions that apply to all applications**
 1. Run `dcomcnfg` to open the DCOM Configuration tool.
 2. Click the **Default Security** tab.

- ▶ **To set the location of a DCOM application**
 1. Run `dcomcnfg` to open the DCOM Configuration tool.
 2. Click the application you want to configure, and then click **Properties**.
 3. Click the **Location** tab, and specify the location of the application.

Troubleshooting Security

To make it easy for customers to contact Microsoft with any potential security issues, an e-mail address has been created: `secure@microsoft.com`. Please use this address to report security issues with a Microsoft product. Microsoft product teams respond to security issues you bring to their attention.

No Windows or Network logon dialog box appears at startup.

When you start Windows 98, you might not receive a Windows or a Network logon dialog box, or you might receive one of the following error messages:

No network provider accepted the given network path.

The operation being requested was not performed because the user has not logged on to the network. The specified service does not exist.

Another symptom of this problem is the absence of the **Change Passwords** tab in the **Passwords Properties** dialog box.

This problem occurs if any of the following conditions are true:

- The primary network logon field is not set correctly.
- The following entry appears in the `HKEY_LOCAL_MACHINE\Software\Microsoft\Windows\CurrentVersion\Network\Real Mode Net` registry key:
`AutoLogon=<x>`

where `<x>` is a number.
- You are logging on to a Novell NetWare network, and the server you log on to is running multiple frame types.
- You are logging on to a Microsoft or NetWare network, and you have cached your network password.
- The network adapter is improperly configured.

Find Fast does not index password-protected files.

Because password-protected files are encrypted, they cannot be indexed. Find Fast does not index password-protected documents because they are not searchable files. Any references to file properties or content will not be addressed in the index. The behavior of Find Fast is, by design, to uphold the security and protection of your documents.

File and Printer Sharing for Microsoft Networks is unavailable.

When you use the right mouse button to click a drive, folder, or printer, there may be no Sharing command on the menu that appears even though File and Printer Sharing for Microsoft Networks is installed. The cause may be that Nwserver.vxd is loading even though File and Printer Sharing for NetWare Networks is not installed in network properties. If this service is installed and you do not use NetWare networks, you need to remove the Microsoft Client for NetWare Networks by clicking Network in Control Panel, clicking **Client for NetWare Networks**, and then clicking **Remove**. Click **OK**, and then restart your computer when you are prompted.

The user list with user-level security is incomplete.

Your Windows 98 system is configured for user-level security with a Windows NT system as the security provider, but when you try to add a user in a shared folder's properties, you may not see a full list of users. Or some users on the network who do not have an account in the user list from the security provider may be able to gain access to your shared Windows 98 computer.

This problem can occur when the security provider is a Windows NT Workstation that is a member of a Windows NT domain. The user list in the **Add Users** dialog box is the list of local user accounts defined on the Windows NT Workstation, but access to the Windows 98 computer is controlled by the accounts in the Windows NT domain.

Use the list of user and group accounts from the Windows NT domain. To do so, specify the name of the domain instead of the Windows NT Workstation on the **Access Control** tab of the Network option in Control Panel.

The selected security provider cannot be found.

When you select user-level security and enter the name of a server to use as a security provider, you may receive the following error message:

Window could not find the specified security provider on the network. Do you wish to use the name you typed anyway?

This error message can occur for any of the following reasons:

- You specified an incorrect server name.
- The server type does not match the services selected for file and printer sharing. For example, you specified a NetWare server but File and Printer Sharing for Microsoft Networks is installed.
- The server is not operational.
- The network has not been started.
- You are not logged on to the Microsoft LAN Manager or the Windows NT domain.

► **To resolve this problem**

1. Verify that the server name you entered is correct.
2. Verify that the server type you specified matches the network services you are running. For example, if you are running File and Printer Sharing for NetWare Networks, make sure to specify a NetWare server.
3. Verify that the server is operational.
4. After you verify the previous items, if the network has not been started, restart the computer.

No logon servers are available.

When you attempt to connect to a share on a Windows 98 computer that is using a Microsoft Windows NT domain to provide user-level security, you may receive the following error message:

There are currently no logon servers available to service the logon request.

This problem may occur regardless of which users have been given access to the share you are connecting to and which access rights each user has been given. It does not occur when the Windows 98 computer you are connecting to is configured for share-level security.

This problem can occur when your user account is configured so that you can log on only to certain computers in the domain. If your user account is configured in this manner and the Windows 98 computer you are attempting to connect to is not one of the specified computers, you are unable to connect to resources on that computer.

To work around the problem, configure the Windows 98 computer you are attempting to connect to for share-level security.

► **To configure Windows 98 for share-level security**

1. In Control Panel, double-click Network, and then click the **Access Control** tab.
2. Click **Share-level access control**, and then click **OK**.
3. Restart the computer when prompted.

Note After you change the type of access control a computer is using, any resources that were shared on that computer are no longer shared. You must share resources again to allow other people access to them.

Additional Resources

| For more information about | See this resource |
|-----------------------------------|--|
| Windows NT | <i>Microsoft Windows NT Server Networking Guide</i> in the <i>Microsoft Windows NT Server Resource Kit</i> (for Microsoft Windows NT Server version 4.0) <i>Microsoft Windows NT Server 4.0 Concepts and Planning Guide</i> |
| Internet security | <i>Microsoft Internet Explorer Administration Kit</i> |
| Proxy servers | <i>Microsoft Proxy Servers Installation and Administrator's Guide</i> http://www.microsoft.com/security/ |

Remote Networking and Mobile Computing

19

This chapter describes how to use Dial-Up Networking and virtual private networking (VPN) to access a network from a remote location. It also describes how other Windows 98 mobile computing tools, such as Briefcase and Direct Cable Connection, can be used to connect to desktop computers or the network. This chapter benefits network administrators who need to install remote access service on clients and servers, implement virtual private networking, or add mobile computing features to clients on the network. It also explains to advanced users how to use Dial-Up Networking, virtual private networking, and mobile computing features.

| | | |
|------------------------|---|-----|
| In This Chapter | Overview of Remote Networking and Mobile Computing | 850 |
| | Overview of Dial-Up and Virtual Private Networking | 851 |
| | Planning for Dial-Up and Virtual Private Networking | 858 |
| | Installing Dial-Up Networking | 860 |
| | Configuring and Using Dial-Up Networking Clients | 861 |
| | Configuring and Using the Windows 98 Dial-Up Server | 872 |
| | Configuring and Connecting to Remote Servers | 877 |
| | Implementing Virtual Private Networking | 885 |
| | Technical Notes on Dial-Up and Virtual Private Networking | 893 |
| | Using Windows 98 Mobile Computing Features | 897 |
| | Troubleshooting Remote Networking and Mobile Computing | 908 |

- See Also**
- For information about network protocols, see Chapter 15, “Network Adapters and Protocols.”
 - For information about setting up modems and Integrated Services Digital Network (ISDN) devices, see Chapter 21, “Modems and Communications Tools.”
 - For information about connecting to the Internet, see Chapter 20, “Internet Access and Tools.”

Overview of Remote Networking and Mobile Computing

Dial-Up Networking, virtual private networking (VPN), and mobile computing allow users not directly connected to the network to work as if they were. *Dial-Up Networking* allows them to make a dial-up connection to remote networks such as the Internet over a telephone or ISDN line. *Virtual private networking* allows users to connect securely to resources on a remote network by “tunneling” over an intermediary network (an existing Internet or local area network [LAN] connection) to a server on the remote network. The intermediary network is used as a substitute for a network wire, enabling you to connect to a server on a remote network even if you are not directly connected to the remote network. Finally, *mobile computing* tools allow intermittently-connected users to access network resources more easily.

Windows 98 Dial-Up Networking allows you to use a computer running Windows 98 as a dial-up client. From a remote site, you can use Dial-Up Networking to connect to a remote access server such as Windows NT version 3.1 or later Remote Access Service (RAS), a Windows 98 dial-up server, a Windows 95 dial-up server, any Point-to-Point Protocol (PPP) server, Novell NetWare Connect version 1.0 or 1.1, or Shiva NetModem or LanRover, using the IP, IPX, and NetBEUI protocols. If the client and server are running the same network protocols, the dial-up client can connect to the network to access its resources. For information about using Windows 98 Dial-Up Networking to dial in to other remote access servers, or using other remote access software to dial in to Windows 98, contact your network vendor or software supplier.

Note A Microsoft Windows NT Client Access License is required if the computer will be connecting to servers running Windows NT Server. For information, see Chapter 16, “Windows 98 on Microsoft Networks,” or contact your Microsoft reseller.

Dial-Up Networking also allows you to designate a computer running Windows 98 as a single-connection dial-up server. A remote user can dial in to the dial-up server and access resources on the dial-up server.

For clients running the IPX or the NetBEUI protocol, the dial-up server can be used to provide access to the network. However, if you need a dial-up server that provides access to the network using Transmission Control Protocol/Internet Protocol (TCP/IP), you should use a Windows NT Server. For more information about the capabilities of the Windows 98 dial-up server, see “Configuring and Using the Windows 98 Dial-Up Server” later in this chapter.

Windows 98 provides the following tools to help users stay as functional as possible with the limited resources of a mobile site:

- Briefcase allows users to update documents on a portable computer with source documents on a desktop computer or network.
- Direct Cable Connection allows users to connect a portable computer to a desktop computer to synchronize files and share other resources.
- Microsoft Outlook Express provides remote access to electronic mail.
- Deferred printing allows users to generate print jobs when no physical printer is available.

Overview of Dial-Up and Virtual Private Networking

Windows 98 includes the following enhancements to Dial-Up Networking:

- Client support for a single virtual private networking connection.
- Support for ISDN modems and adapters.
- Multilink capabilities.
- Connection-time scripting to automate nonstandard logons.
- Improved performance and stability.

This section provides an overview explanation of how you can use these enhancements and other Dial-Up Networking features for remote access. For information about ISDN, see Chapter 21, “Modems and Communications Tools.”

With Dial-Up Networking and virtual private networking, you can connect from a remote site to a computer that has been configured as a remote access server, or connect to a network through the remote access server. For example, as Figure 19.1 shows, if you connect to a Windows NT Remote Access Server, you can access its shared resources (if the Microsoft File and Printer Sharing service has been enabled), or you can use it as a gateway to a network that is running the TCP/IP, IPX/SPX, and NetBEUI network protocols.

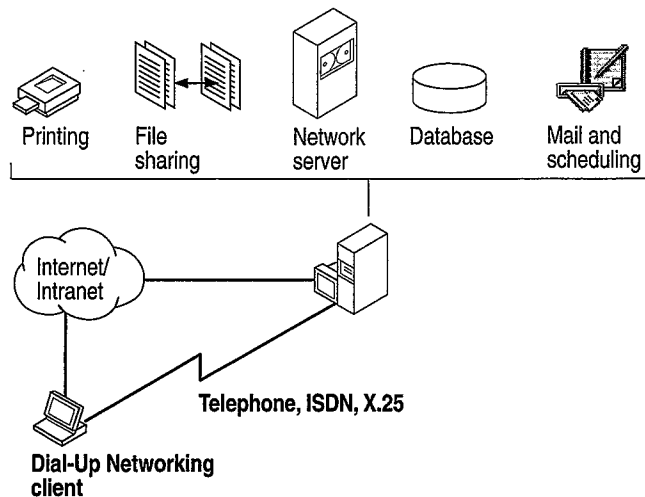

Figure 19.1 Connecting to a remote access server

Figure 19.1 illustrates two types of connections: a dial-up connection and a virtual private network connection through the Internet. You would use either the dial-up connection or the virtual private network connection to access those resources.

Note You can also access shared resources by connecting to a Windows 98 dial-up server. For a description of the capabilities and limitations of the Windows 98 dial-up server, see “Configuring and Using the Windows 98 Dial-Up Server” later in this chapter.

As Figure 19.2 shows, a Windows 98 dial-up client can connect to a wide variety of networks, because Windows 98 supports a variety of connection and network protocols.

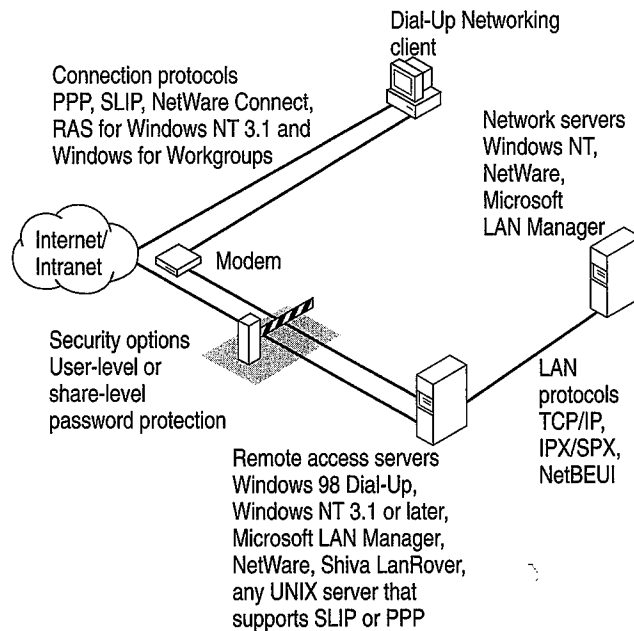

Figure 19.2 Connecting to remote networks

With virtual private networking, you can connect to remote servers not only over telephone lines, but also over Internet connections and the corporate intranet. This provides the following benefits:

Inexpensive remote access With virtual private networking, remote users can connect to your company's network from the Internet instead of over a telephone line, so you do not need to maintain modem pools or pay long-distance charges. Your network must have a Windows NT Remote Access Server (RAS) virtual private networking server and a dedicated connection to the Internet, such as a 56Mbits, fractional T-1, T-1 connection. Users simply dial in to their local Internet Service Providers (ISPs) and then connect to the RAS VPN server over the Internet.

Secure access to private data In Windows, 98, virtual private networking is implemented using Point-to-Point Tunneling Protocol (PPTP). Because PPTP is a secure protocol, only authenticated users can gain access to your dial-up server. Also, you can encrypt data transfer to prevent Internet intruders from listening in.

Private addressing schemes Using certain types of routers and gateway servers, it is possible to connect your network to the Internet so that all your computers and their IP addresses are visible on the Internet. However, this configuration presents two drawbacks. First, your computers are vulnerable to attack by intruders on the Internet. Second, you must obtain IP addresses that conform to the Internet addressing scheme. Using virtual private networking, on the other hand, you can configure all the computers on your private intranet by using a private addressing scheme that does not need to conform to the Internet addressing scheme. The VPN server then shields the internal addresses from the rest of the Internet. The IP addresses of the computers on your private intranet remain hidden, providing additional security for those computers.

Different remote access servers provide different security systems to protect access to a network. The Windows 98 dial-up server uses pass-through (user-level) or share-level security as described in "Configuring Security Options for a Windows 98 Dial-Up Server" later in this chapter.

Dial-Up Networking uses the Windows 98 communications architecture to communicate through a modem to a network. It initializes the modem, determines device status, and dials the telephone number by using the telephony application program interface (TAPI) and the Unimodem driver. For more information about the communications architecture and the Dial-Up Networking architecture, see Chapter 29, "Windows 98 Network Architecture."

A Windows 98 Dial-Up Networking configuration includes the components described in the following sections

Dial-Up Client

With Dial-Up Networking, you can configure a remote computer running Windows 98 as a dial-up client to dial in to a remote access server. A dial-up client, running the appropriate connection protocol, can connect to many types of remote access servers, including the following:

- Windows NT 3.51 or later Server computer.
- Windows NT 3.51 or later Workstation computer.
- Windows 98 dial-up server.
- Windows 95 dial-up server.
- Windows for Workgroups version 3.11.
- NetWare Connect 1.0 or 1.1.
- Any network access server that supports PPP (including NetWare Connect 2.0).
- Any UNIX server that runs Serial Line Internet Protocol (SLIP) or PPP.

Connection Protocols

Connection protocols control the transmission of data over the wide-area network (WAN). A Windows 98 dial-up client can use the following connection protocols to connect to a remote access server:

- PPP.
- Novell NetWare Connect 1.0 and 1.1.
- Windows NT 3.1 or Windows for Workgroups RAS (Asynchronous NetBEUI).
- SLIP.

The type of connection protocol you choose depends on the server you are connecting to. Some connection protocols support a subset of the common network protocols. For example, PPP allows you to connect to a network server or a computer running Windows 98 with TCP/IP, IPX/SPX-compatible, or NetBEUI network protocols.

This section describes the connection protocols.

Point-to-Point Protocol Point-to-Point Protocol (PPP) provides a standard method for transporting multi-protocol datagrams over point-to-point links. It has become the standard for remote access because of its flexibility, password encryption security, and compatibility with future client and server hardware and software. A dial-up client running PPP can connect to a network running IPX, TCP/IP, or NetBEUI protocols. Windows 98 dial-up clients can use PPP to connect to any remote access server running PPP, including Windows NT Server version 3.51 or later. PPP is the default protocol for the Microsoft Dial-Up adapter.

Novell NetWare Connect NetWare Connect 1.0 and 1.1 is a proprietary connection protocol. It allows a computer running Windows 98 to connect directly to a NetWare Connect 1.0 or 1.1 server and, if running a NetWare-compatible network client, connect to NetWare servers.

Windows 98 can connect to NetWare Connect 2.0 using PPP. For information about PPP, see "Technical Notes for PPP-Compatible Servers" later in this chapter.

Note Windows 98 can act only as a client for connecting to a NetWare Connect 1.0 or 1.1 server. NetWare Connect 1.0 or 1.1 clients themselves cannot directly connect to a Windows 98 dial-up server through a dial-up connection.

RAS for Windows NT 3.1 or Windows for Workgroups 3.11 (Asynchronous NetBEUI)

Asynchronous NetBEUI is used to connect computers running Windows 98 to remote access servers running Windows NT Server 3.1 LAN Manager, or Windows for Workgroups 3.11. It is also supported by Windows NT Server 3.5 and later. The remote access server must also be running NetBEUI.

Serial Line Internet Protocol SLIP is an older remote access standard that is typically used by UNIX remote access servers. Use SLIP only if your site has a UNIX system configured as a SLIP server for Internet connections. The remote access server must be running TCP/IP.

Windows 98 does not provide SLIP server capabilities; SLIP is used for client dial-out only.

Local Area Network Protocols

Windows 98 makes it easy to configure dial-up clients to access a network. When you install Dial-Up Networking, any protocols already installed on the computer are automatically enabled for Dial-Up Networking. Windows 98 includes support for TCP/IP, IPX/SPX, and NetBEUI network protocols.

Note In Properties for your Dial-Up Networking connection, all network protocols show up as automatically enabled. However, remember that you cannot use them unless they have actually been installed on your computer. For information about how to install network protocols, see Chapter 15, "Network Adapters and Protocols."

The following list presents the combinations of protocols you can use to run either Windows Sockets or NetBIOS applications on a network.

| Connection protocol | Network protocols (APIs) |
|--|--|
| NetWare Connect 1.0 or 1.1 | IPX/SPX (Windows Sockets/NetBIOS) |
| PPP | TCP/IP (Windows Sockets/NetBIOS) IPX/SPX (Windows Sockets/NetBIOS) NetBEUI (NetBIOS) |
| RAS for Windows NT 3.1 or Windows for Workgroups 3.11 | NetBEUI (NetBIOS) |
| SLIP | TCP/IP (Windows Sockets/NetBIOS) |

Figure 19.3 shows the protocols Dial-Up Networking clients can use to connect to host servers and to remote networks.

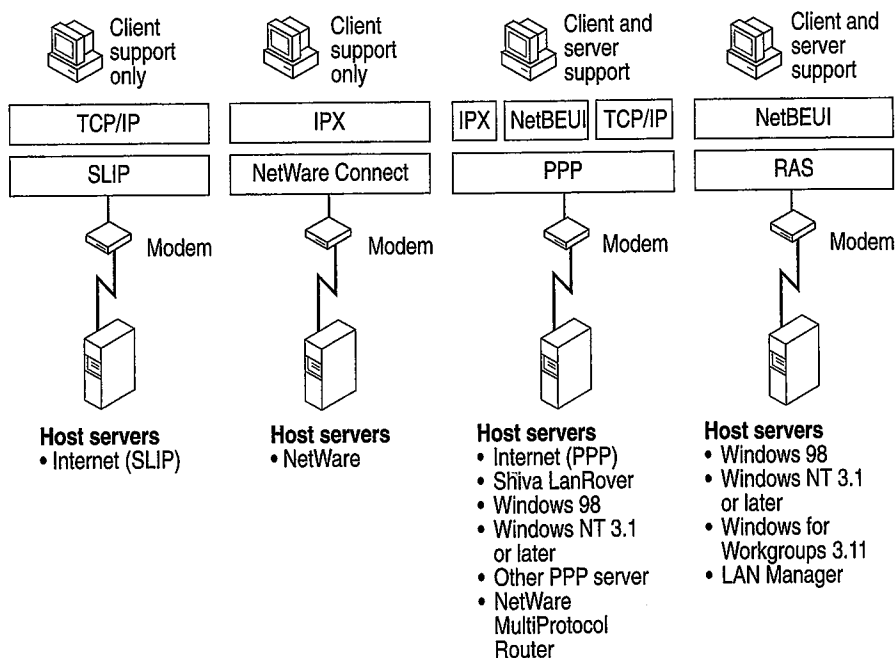

Figure 19.3 Connection protocols

Dial-Up Server

You can designate a computer running Windows 98 a single-connection dial-up server. If both the server and the client are running IP, IPX, or NetBEUI, the dial-up server can provide access to its shared resources. If both the server and the client are running IPX or NetBEUI, the dial-up server can act as a gateway to a network running the same protocol. For more information about the capabilities of the Windows 98 dial-up server, see "Configuring and Using the Windows 98 Dial-Up Server" later in this chapter.

Using Software and Hardware Compression to Transfer Data

To improve the throughput and transfer times when you use Dial-Up Networking, Windows 98 supports dynamic compression of information when you are connected to another computer that also supports compression—for example, a computer running Windows 98 or Windows NT.

You do not need to perform any special configuration to enable hardware and software compression. Software compression on the client is enabled by default and is available for PPP connections. You should leave it enabled. Hardware compression is also enabled by default and is performed by the modem. You should leave it enabled. For more information about hardware compression, see Chapter 21, “Modems and Communications Tools.”

Using Data Encryption for Dial-Up Clients

You do not need to perform any special configuration to enable data encryption on dial-up clients. This option can be required by either the server or the client. For instructions on how to configure a Dial-Up connection so that the dial-up client will refuse to connect to a server that does not support data encryption. For instructions, see “Configuring a Dial-Up Connection,” later in this chapter.

Data encryption requires that the client and server share a common key, which is generated at connection time using Microsoft Challenge Handshake Authentication (MS-CHAP).

Security Options for Dial-Up Clients and Servers

Dial-Up Networking servers can be configured with either user-level or share-level security. Additionally, a Dial-Up Networking client can be configured to use encrypted passwords if the server it is connecting to supports that feature. For more information, see “Configuring Security Options for a Windows 98 Dial-Up Server” later in this chapter.

Planning for Dial-Up and Virtual Private Networking

To use Dial-Up Networking to connect to the Internet or a remote network, you need the following hardware:

- One or more compatible modems or ISDN devices, as described in Chapter 21, “Modems and Communications Tools.”
- Enough available hard disk space to install Dial-Up Networking. Currently, about 2 to 3 MB of free disk space are required to install the client and server portions of Dial-Up Networking.

In most cases, you will need the same hardware to use virtual private networking to connect to a remote network through the Internet. If you will be connecting to a remote network through a VPN server on your corporate network and you will never make a dial-up connection, you will not need a modem or ISDN device, but you will need a network adapter that is physically connected to the LAN.

To use a Dial-Up Networking client to connect to the network, you need to decide the following:

- The kind of remote access server remote users will connect to. For example, a Windows 98 dial-up server allows only 1 remote connection at a time, whereas a Windows NT Server 3.5 or later remote access server allows 256 connections. Depending on the size and needs of your network, you might configure a Windows 98 dial-up client to connect to a Windows NT Server 3.5 or later remote access server or another remote access server. For a list of the types of remote access servers that a Windows 98 dial-up client can be configured to connect to, see “Dial-Up Client” earlier in this chapter.
- The type of connection protocol your dial-up client will use to connect to the remote access server. Windows 98 provides support for PPP, RAS for Windows for Workgroups 3.11 and Windows NT 3.1, NetWare Connect 1.0 and 1.1, and SLIP. The dial-up client and the remote access server must both be running the same connection protocol. For a complete list of protocol types, see “Connection Protocols” earlier in this chapter.
- The kind of network protocol to install on the dial-up client to connect the client to the network. Windows 98 dial-up clients support IPX/SPX, TCP/IP, and Microsoft NetBEUI protocols. For more information about network protocols and Dial-Up Networking, see “Local Area Network Protocols” earlier in this chapter.

If you want to add a Windows 98 dial-up server to your network, you need to decide the following:

- Which computers on the network will function as Windows 98 dial-up servers.
- Whether you want to connect the client to the network and what kind of network protocol you need to install on the dial-up server. Windows 98 dial-up servers support only the IPX/SPX and Microsoft NetBEUI protocols; to use TCP/IP to connect the client to the network, you must use a Windows NT Server instead of a Windows 98 dial-up server.
- The level of security you need for dial-up servers. You can enable either user-level or share-level security on a Windows 98 dial-up server. For more information, see “Configuring Security Options for a Windows 98 Dial-Up Server” later in this chapter.

Installing Dial-Up Networking

By default, Windows 98 Setup automatically installs Dial-Up Networking, other communications tools, and most of the components you need to connect to a network. Table 19.1 shows the communications tools that appear in the **Add/Remove Programs** option in Control Panel. For information about which of these tools are installed by default under the Typical, Portable, Compact, or Custom installations, see Chapter 2, "Setting Up Windows 98."

Table 19.1 Communications tools available in Windows 98

| Tool | Purpose |
|----------------------------|---|
| Dial-Up Networking | Allows a Windows 98 computer to access a network or the Internet from a remote location. |
| Dial-Up Server | Gives a Windows 98 computer the ability to provide remote access to a single dial-up client. |
| Direct Cable Connection | Allows you to establish a direct serial or parallel cable connection between two computers. |
| HyperTerminal | Provides file transfer and terminal emulation capabilities. |
| Infrared | Allows a Windows 98 computer to communicate with other computers or the network using infrared. |
| Microsoft Chat 2.0 | Allows you to chat with people on a chat server. |
| Microsoft NetMeeting | Allows you to call people on the Internet or a corporate intranet and talk, share applications, draw on a shared whiteboard, or share files and messages. |
| Phone Dialer | Allows a Windows 98 computer to make voice calls. |
| Virtual private networking | Allows a Windows 98 computer to connect securely to a remote server over telephone lines, the Internet, or a corporate intranet. |

If you want to add an additional component, you must install it after running Windows 98 Setup.

► **To add an additional component**

1. In Control Panel, double-click **Add/Remove Programs**, and then click the **Windows Setup** tab.
2. Double-click **Communications** in the list of components.
3. Select the component.
4. Click **OK**, and then click **Apply**.

Windows 98 Setup also installs most of the components you need to connect to a network. For example, Windows 98 installs the Microsoft Dial-Up adapter, connection protocols, and the Microsoft TCP/IP network protocol if TCP/IP has not already been installed on the computer.

Note If you are upgrading from Windows 3.1 or Windows for Workgroups, Setup does not upgrade your phonebook entries (your connection information). You must reenter all connection information. However, if you are upgrading from Windows 95, Setup does upgrade your connection information.

However, Windows 98 Setup does not automatically install network protocols such as IPX/SPX and NetBEUI. If you need to use those protocols but they are not already installed on your computer, you must install them.

To verify that the correct protocols are installed, in Control Panel, double-click Network, and then check the list of installed components.

For information about adding protocols, see Chapter 15, "Network Adapters and Protocols."

Configuring and Using Dial-Up Networking Clients

Configuring computers as Dial-Up Networking clients consists of four tasks:

- Running the Install New Modem Wizard to install a modem.
- Configuring Telephony Dialing Properties.
- Running the Make New Connection Wizard in Dial-Up Networking to set up a connection to a remote access server for the dial-up client.
- Optionally, configuring the connection by selecting the remote access server type it will connect to, and by choosing whether to log on to the network after connecting to the remote access server. Selecting the server type automatically enables the correct connection protocol, such as PPP or SLIP.

This section explains how to perform these four tasks.

Installing a Modem

If you have not already installed a modem, the Install New Modem wizard appears when you start Dial-Up Networking. It guides you through the process of installing a modem. For more information about modems, see Chapter 21, "Modems and Communications Tools."

Configuring Telephony Dialing Properties

After the Install New Modem wizard installs your modem, a **Location Information** dialog box appears. This dialog box asks for such information as what country you are in and what area code you are in. Windows 98 uses this information to establish a dialing rule (called a *dialing location*). Whenever you dial a call, Windows 98 uses this dialing rule to automatically adjust your dialing string. For example, if you enter "425" as your area code in the **Location Information** dialog box, then later try to dial the number "425-555-1212," Windows 98 adjusts the dialing string to "555-1212."

If you have a portable computer and frequently dial from different places, you might also want to use the Dialing Properties utility to create different dialing locations for each place. You can also define calling card rules that you can use with one or more of your dialing locations.

Note The information you entered in the **Location Information** dialog box also appears in the Dialing Properties utility, as your default dialing location.

The remainder of this section describes how to establish and use different calling locations using the Dialing Properties Utility. For more information about the Dialing Properties utility, including how to define calling card rules, see "Using Dialing Properties" in Chapter 21, "Modems and Communications Tools."

The Dialing Properties utility allows you to define different locations from which you dial. For each location, enter your country code, area code, and other information about the place you are dialing from. You can then dial a number using Dial-Up Networking, and Windows 98 automatically adjusts your dialing string based on the location from which you are calling.

For example, suppose you commonly dial from two different places:

- **Your home** in the 206 area code region. You do not need to dial an outside line, but you dial *70 for each call to disable call waiting.
- **Your office** in the 801 area code region. To reach an outside line, you must dial 9.

You can create two different locations (home and office) and enter area code and other information for each location. Then, whenever you make a dialing location, Dialing Properties automatically adjusts the telephone number based on the place you are calling from.

For example, suppose you have defined a Dial-Up Networking Connection to your ISP at 206-555-5555.

If you are dialing from home, Dialing Properties adjusts the telephone number to *70,555-5555. But if you are dialing from your office, Dialing Properties changes the telephone number to 9,1-206-555-5555.

You can access Dialing Properties from several different places, including the Modems icon in Control Panel, the Telephony icon in Control Panel, and the connection you are dialing.

► **To define a new dialing location**

- In Dialing Properties, enter the name of your new dialing location, the area code you are dialing from, and other information about your location. Optionally, enter information about your calling card. This information will then be available to any Dial-Up Networking connection that you create.

► **To use the dialing location**

1. When you configure the General properties for a Dial-Up Networking connect (described in “Configuring General Properties” later in this chapter), make sure that the check box “**Use area code and Dialing Properties**” is selected.
2. When you dial the connection (described in “Making a Dial-Up Networking Connection” later in this chapter), make sure that you have selected the correct dialing location.

Defining a Dial-Up Networking Connection

When you first start Dial-Up Networking, the Make New Connection Wizard appears. You can define two different types of remote connections:

- A dial-up connection allows you to use modems or ISDN devices to connect to the Internet or your intranet.
- A VPN connection uses two connections. With the first connection, you use a network adapter, modem, or ISDN device to connect to a remote access server on the Internet or your intranet. With the second connection, you can “tunnel through” the first connection to a VPN tunnel server, in order to gain access to any server that the VPN tunnel server allows you to access.

Before creating a new dial-up connection, you should install a modem, ISDN device, or network adapter. If you have not yet installed a modem and did not install a modem when Dial-Up Networking started, you can install one by using the Install New Modem Wizard in the Modems option in Control Panel. For information about modems and ISDN devices, see Chapter 21, “Modems and Communications Tools.”

Additionally, if you are configuring a VPN connection, you must first install virtual private networking. To do so, follow the procedure “To add an additional component” described in “Installing Dial-Up Networking” earlier in this chapter.

▶ **To create a Dial-Up Networking connection using the Make New Connection Wizard**

1. From My Computer, double-click the Dial-Up Networking folder.
2. In the **Dial-Up Networking** window, double-click the Make New Connection icon.
3. In the **Type a name for the computer you are dialing** dialog box, enter a name for your connection.
4. If you are creating a dial-up networking connection, in the **Select a device** box select a modem or ISDN device.

–Or–

If you are creating a VPN connection, in the **Select a device:** box select **Microsoft VPN Adapter**.

5. If you are creating a dial-up networking connection, the Make New Connection Wizard prompts you for information about your connection, such as a name for the computer you are dialing, modem type, area code, telephone number, and country code.

–Or–

If you are creating a VPN connection, the Make New Connection Wizard prompts you for the host name or address of the VPN server.

6. The new icon for your connection appears in the **Dial-Up Networking** window. You need to provide this information only once for each connection you define.

Once a connection has been established, remote network access becomes transparent to the user.

Configuring a Dial-Up Connection

The Dial-Up Networking defaults for the dial-up connection are designed for Internet connections and for most other types of connections. You can change these defaults, but you should do so only if you want to change the default behavior.

There is one exception. By default, Dial-Up Networking uses the PPP protocol to connect to servers. This default will work for most Internet connections and many other types of connections. But if you are connecting to a server that does not use PPP, you must change the server type by following the procedure in “Configuring Options for the Server to Which You Are Connecting” later in this chapter.

You can configure the following options:

- General properties
- Server properties
- Scripting
- Multilink

You can predefine Dial-Up Networking connections for users by including them as part of system policies. If you enable user profiles, different users sharing the same computer can use separate dialing configurations. For more information, see Chapter 7, “User Profiles,” and Chapter 8, “System Policies.”

Configuring General Properties

This section describes how to configure basic options for a dial-up connection.

▶ To configure general properties for the connection

1. In Dial-Up Networking, right-click a connection icon, and then select **Properties** from the **File** menu.
2. Review the information on the **General** tab to ensure that the telephone number is correct and that the correct modem or ISDN device is selected. Ensure that **Use area code and Dialing Properties** is selected if you have defined one or more dialing locations as described in “Configuring Telephony Dialing Properties” earlier in this chapter. Make any necessary changes.
3. Click **Configure**, and then click the **Options** tab.
4. Optionally, click **Bring up terminal window before dialing** or **Bring up terminal window after dialing**. For modem connections, these options allow you to use a terminal window for an interactive logon session with the server.

Configuring Options for the Server to Which You Are Connecting

Dial-Up Networking allows you to configure options for the server to which you are connecting. You do not need to change any values in this section if you are connecting to an ISP and your ISP’s remote access server supports PPP.

▶ To configure options for the server to which you are connecting

1. In Dial-Up Networking, right-click a connection icon, and then click **Properties**.
2. Click the **Server Types** tab.

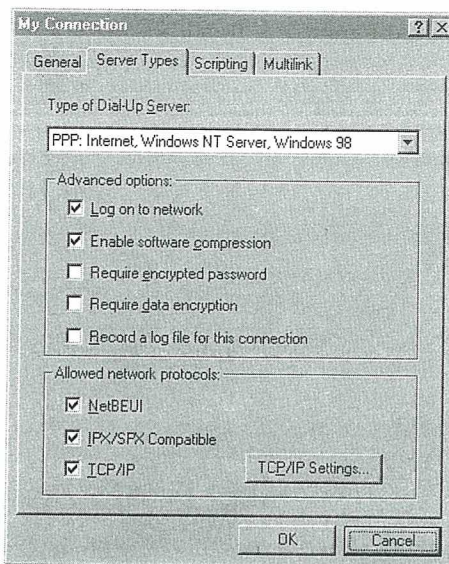

3. In the **Type of Dial-Up Server** box, ensure that the correct remote access server type is selected. If it is not selected, you will not be able to connect to the server. The possible connections are as follows:

| This server type | Connects to |
|---|---|
| PPP: Internet, Windows NT Server, Windows 98 | The default; selecting it allows Windows 98 to automatically detect and connect to other remote access servers that are running TCP/IP, NetBEUI, or IPX/SPX over PPP. Select this option for connections to your ISP. |
| NRN: NetWare Connect version 1.0 and 1.1 | Novell NetWare Connect 1.0 or 1.1 running IPX/SPX over NetWare Connect 1.0 or 1.1. |
| SLIP: UNIX Connection | Any SLIP server over TCP/IP. |
| Windows for Workgroups and Windows NT 3.1 | Windows 98 dial-up server; Windows NT 3.1 or 3.5; Windows for Workgroups version 3.11 running NetBEUI over RAS. |
| CSLIP: UNIX Connection with IP Header Compression | Any SLIP server over TCP/IP that supports IP header compression. |

4. Optionally, if you are making a connection to an ISP, deselect **Log on to network** to speed connection time. This option is selected by default, but it is unnecessary for Internet connections.

5. Optionally, select **Require encrypted password**. If this option is selected, the client will use only Challenge Handshake Authentication Protocol (CHAP) and MS-CHAP encryption when generating a password. If this option is not selected, the client can also perform Password Authentication Protocol (PAP) if the server requests it. However, PAP encryption is less secure. For more information about encryption, see "PPP Dial-Up Sequence" later in this chapter.
6. Optionally, select **Require data encryption**. If this option is selected, the client will refuse to connect with any server that does not use data encryption. However, most ISPs do not support data encryption. For more information, see "Using Data Encryption for Dial-Up Clients," earlier in this chapter.
7. Optionally, select **Record a log file for this connection**. If this option is selected, Dial-Up Networking will create a PPP log file that shows information about your connection. For information about PPP log files, see "PPP Log File" later in this chapter.
8. In the **Allowed network protocols** box, ensure that the network protocols used on the target network are selected. For example, if you are configuring a connection to the Internet, ensure that TCP/IP is selected.

Note By default, all network protocols (TCP/IP, IPX/SPX, and NetBEUI) are selected in the **Allowed network protocols** box. However, for you to use those protocols, they must also be installed on the client workstation you are configuring. For information about how to install protocols, see Chapter 15, "Network Adapters and Protocols."

9. Optionally, if you are configuring a connection to your ISP and your ISP requires you to enter information such as a static IP address for your computer or a DNS server to which you must connect, click **TCP/IP Settings**. However, in most cases you do not need to do so. For more information, see Chapter 20, "Internet Access and Tools."

Configuring Scripting for Modem Connections

Windows 98 supports scripting on modem connections (not on ISDN or VPN connections.) In most cases, you do not need to create a script. Many ISPs do not require a manual logon, and ISPs that do require a manual logon almost always provide a script file you can use. Contact your ISP for more information.

However, if you need and do not have a logon script, you can create one. Windows 98 provides four sample scripts you can use as starting points. The sample scripts are located in your **\Program Files\Accessories** directory. Windows 98 also includes a document that explains how to write and modify logon scripts. The file is called Script.doc and located in your Windows directory.

After you have created a script, save it in your **\Program Files\Accessories** directory, using the file extension SCP.

Important Microsoft does not support logon scripts you create. Also, Microsoft does not support modifications to the four sample scripts.

After you have created the script, you must configure scripting for each connection that will use the script. Make sure your connection is working properly before you configure scripting.

▶ **To configure scripting for the Windows 98 dial-up client**

1. In Dial-Up Networking, right-click a connection icon, and then click **Properties**.
2. Click the **Scripting** tab, and then click **Browse**.
3. Locate the script, and then click **Open**.
4. Optionally, select the **Step through script** box.
Selecting the **Step through script** box enables you to step through the script to verify that each line is working correctly, or to troubleshoot the script if the connection fails.
5. Click **OK**.

Configuring Multilink

The PPP Multilink protocol allows you to use two or more devices (such as modems or ISDN devices) for a single dial-up link. With Multilink, you combine the bandwidth capabilities of both devices, thus inexpensively increasing the bandwidth on your dial-up connections. This section describes how to use Multilink. For additional information about Multilink, and for information about ISDN, see Chapter 21, "Modems and Communications Tools."

The Windows 98 PPP Multilink implementation complies with the Internet Engineering Task Force (IETF) PPP Multilink standard defined by Request for Comments (RFC) 1717.

Before using Multilink, consider the following issues:

- Multilink is available only for Windows 98 dial-up clients, not for the Windows 98 dial-up server.
- The server or ISP you connect to must also support PPP Multilink. Otherwise, Multilink will not function correctly.
- You can use Multilink only when your computer is configured with multiple devices that can be combined to form the logical PPP pipe over the communication link.
- For best performance, the devices you use should be the same speed.
- When you combine both B channels under ISDN, you cannot use your second channel for other applications, such as fax or voice calls.

- ▶ **To configure Multilink for the Windows 98 dial-up client**
 1. In Dial-Up Networking, right-click your connection icon, and then click **Properties**.
 2. Click the **Multilink** tab.
 3. Select **Use additional devices**.
 4. Click **Add**.
 5. Specify the additional device you wish to use.
 6. If you need to edit an entry, click **Edit**.

- ▶ **To use Multilink**
 - After you have configured Multilink, click the connection icon and click **Connect**. Dial-Up Networking connects using the primary device, then the secondary device.

- ▶ **To view information about your link**
 1. Click the Dial-Up Networking icon displayed on your taskbar.
 2. In the dialog box, click **Details**.

Configuring a Connection to the Internet

To configure a Windows 98 Dial-Up Connection to dial the Internet, follow the procedures outlined in “Configuring and Using Dial-Up Networking Clients” earlier in this chapter. Keep in mind the following issues:

- Before you begin, check to make sure TCP/IP is correctly installed on your computer.
- If you want to use a terminal window for an interactive logon session with the server, in the modem’s Properties, click **Bring up terminal window before dialing** or **bring up terminal window after dialing**.
- If you are using SLIP instead of PPP to connect to the Internet, in the **Server Types** dialog box, select **SLIP: UNIX Connection**.
- If you want to speed your connection time, in the **Server Types** dialog box, deselect **Log on to network**. This option is not necessary for Internet connections.
- If your ISP requires you to enter information such as an IP address for your computer or the IP address of a DNS server, enter this information in the **Server types** dialog box. In most cases, you will not need to enter information here. For more information, see Chapter 20, “Internet Access and Tools.”

Making a Dial-Up Networking Connection

After you have defined a remote connection by using the Make New Connection Wizard, you can make a connection.

Note If you selected **Use area code and Dialing Properties** in the General Properties for your connection, Dial-Up Networking automatically adjusts the dialing string (telephone number) according to your dialing location (the place you're dialing from). For more information about your dialing location, see "Configuring Telephony Dialing Properties" earlier in this chapter.

► **To make a Dial-Up Networking Connection**

1. Double-click its connection icon in the Dial-Up Networking folder.
2. Optionally, enter a user name and password.
3. If you selected **Use area code and Dialing Properties** in the General Properties for your connection, in the **Dialing from** area, ensure that you have selected the correct dialing location (the place you are dialing from). If necessary, select another dialing location or click **Dial properties** to define a new dialing location.

After a connection has been made, a connection icon appears in the system tray. You can double-click this icon to see information about the connection, such as the server type it is using, the protocols it is using, and whether it is using authentication and compression.

Note If you are using PPP to connect to the remote server and you are dialing in to an IPX network, you will lose IPX connectivity to your local network. Thus, after you make a dial-up networking connection, NetWare servers on the local network will no longer be visible.

You might also lose IP connectivity to your local network if you are dialing in to an IP network. For specific details and for ways to restore IP connectivity, see "Technical Notes on Dial-Up and Virtual Private Networking" later in this chapter.

Dial-Up Networking starts automatically in certain circumstances, through an autodial feature included in Dial-Up Networking and an autodial feature included in the Internet Explorer 4 browsing software. The following sections describe the two features.

Using the Dial-Up Networking Autodial Feature

Dial-Up Networking provides an autodial feature. If autodial is enabled, Windows 98 starts Dial-Up Networking when you try to perform one of the following tasks:

- You try to access a network resource when your computer is not connected to any network.
- You try to access a network resource that you have accessed before using Dial-Up Networking.
- Your application specifies a UNC name (which uses the form `\\servername\sharename`) that cannot be accessed by using the network.

Note The Dial-Up Networking autodial feature is separate from the Internet Explorer browsing software autodial feature, described below.

When you choose a remote connection, Windows 98 retrieves the server information from the addresses stored in the registry. If the information is not available, you are asked to select a server from the connection icons in Dial-Up Networking, or to type a new server name.

If Dial-Up Networking cannot find the network resource, it displays a network error message. If the connection is successful, Windows 98 remembers the connection for future use.

You can disable the prompt that asks if you want to use Dial-Up Networking when you are attempting to connect to a network resource.

► **To disable the Dial-Up Networking prompt**

1. In Dial-Up Networking, click the **Connections** menu, and then click **Settings**.
2. Click **Don't prompt to use Dial-Up Networking**.

Using the Internet Explorer Browsing Software Autodial Feature

The Internet Explorer browsing software includes an autodial feature that can automatically start Dial-Up Networking while you are browsing. When you start the Internet Explorer browsing software or try to access a URL that is not locally available, and you have not already established a Dial-Up Networking connection, a dialog box appears and asks you if you want to use Dial-Up Networking.

Note The Internet Explorer autodial feature is separate from the Dial-up Networking autodial feature, described above.

The Internet Explorer browsing software starts Dial-Up Networking only if you have a modem and you have configured the Internet Explorer browsing software to automatically start Dial-Up Networking.

The following procedure shows how to do so.

▶ **To configure the Internet Explorer browsing software to automatically start Dial-Up Networking**

1. In Control Panel, double-click Internet, and then click the **Connection** tab.
2. In the **Connection** box, select **Connect to the Internet using a modem**.
3. Optionally, click the **Settings** box to specify a particular Dial-Up Networking connection and to enter information about that connection.

The following procedure shows how to configure the Internet Explorer browsing software to not start Dial-Up Networking.

▶ **To configure the Internet Explorer browsing software to not start Dial-Up Networking**

1. In Control Panel, double-click Internet, and then click the **Connection** tab.
2. In the **Connection** box, select **Connect to the Internet using a local area network**.

Configuring and Using the Windows 98 Dial-Up Server

With Dial-Up Networking, you can configure a computer running Windows 98 to be a remote access server for dial-up clients running Windows 98, Windows 95, Windows for Workgroups, or Windows 3.1, or any other client running PPP. The Windows 98 dial-up server can act as a server to the client, sharing its file and printer resources with one dial-up client at a time. Both the dial-up server and the dial-up client must be running the same protocol (IP, IPX, or NetBEUI). The Windows 98 dial-up server can also act as a gateway to an IPX/SPX or NetBEUI network, as long as both the client and the server are using the same protocol that is used on the network.

The Windows 98 dial-up server supports software compression. It also works with ISDN; however it can use only one B channel.

A Windows 98 dial-up server differs from the Windows NT 3.5 and later dial up servers in the following ways:

- Windows NT Server 4.0 and later can act as a VPN server; Windows 98 cannot.
- Windows NT Server 3.5 and later can act as an IP router; Windows 98 cannot. IP router capabilities permit access to a TCP/IP network, such as the global Internet. Windows 98 provides all the protocols you need to connect to the Internet but cannot act as an IP router.
- Windows NT Server 3.5 and later support 256 remote connections, whereas Windows 98 provides one remote connection.

A Windows 98 dial-up server with the appropriate network protocols installed can act as a NetBIOS gateway, as shown in Figure 19.4.

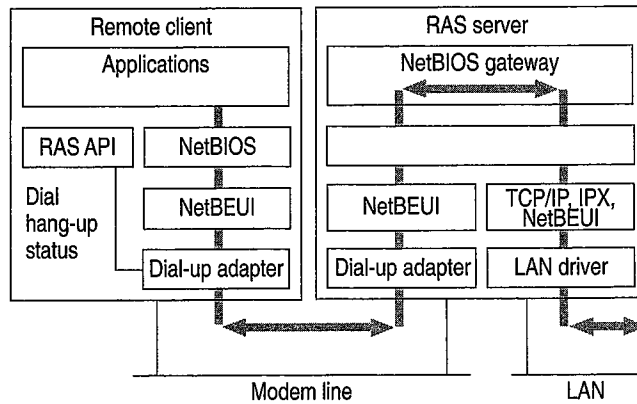

Figure 19.4 Dial-up server as NetBIOS gateway

Configuring a computer running Windows 98 to be a dial-up server consists of the following steps:

- Installing the Dial-Up Server, as described in “Installing a Windows 98 Dial-Up Server,” later in this chapter.

- Optionally, enabling file and printer sharing services for either Microsoft or NetWare networks on the dial-up server. Perform this step only if you want the dial-up server to share files with the dial-up clients. For more information, see Chapter 18, “Logon, Browsing, and Resource Sharing.”
- Enabling user-level or share-level security on the dial-up server. For information, see “Configuring Security Options for a Windows 98 Dial-Up Server” later in this chapter.
- Configuring the server type for the dial-up server, as described in the section “Configuring the Server Type for the Dial-Up Server” later in this chapter.

After you perform the steps previously listed, your Dial-Up Server will be ready to answer incoming calls.

- ▶ **To disconnect any users who are currently connected to this computer through Dial-Up Networking**
 - In the **Dial-Up Server** dialog box, click **Disconnect User**.

Note The Dial-Up Server for Windows 98 can use only one modem at a time. You can enable caller access on multiple modems at any one time, but only one modem can be connected.

Installing a Windows 98 Dial-Up Server

In Windows 98, the Dial-Up Server is not automatically installed. To install it, follow this procedure.

- ▶ **To install the Dial-Up Server**
 1. In Control Panel, double-click **Add/Remove Programs**, and then click the **Windows Setup** tab.
 2. In **Add/Remove Programs Properties**, double-click **Communications**.
 3. Select the **Dial-Up Server** check box, and then click **OK**, and then click **OK** again.

Configuring Security Options for a Windows 98 Dial-Up Server

Dial-Up Networking gives you the option of requiring a password to connect to the remote access server, depending on whether the Windows 98 dial-up server is protected with share-level or user-level security.

- Share-level security assigns a password to the Windows 98 dial-up server. When users dial in, they must provide the password before they can gain access to the server. After the connection is established, users can browse the resources on the dial-up server, subject to whatever level of security has been applied to them. Users can also log on to the network after connecting to the dial-up server if logging on to the network is enabled on the dial-up client. Because users can distribute passwords, this method is less secure than user-level security.
- User-level security restricts access to a network resource until a security provider, such as a Windows NT domain controller or a NetWare server, authenticates the request. You can require that a user's logon password to a remote access server be the same as the network and Windows 98 logon passwords.

With user-level security, when the user accesses shared resources on the dial-up server, Windows 98 controls a user's rights to the shared resources, such as whether the user has read-only access or full access to files. Access rights are specified in the sharing properties for each resource protected by user-level security. For more information, see Chapter 9, "Security," and Chapter 18, "Logon, Browsing, and Resource Sharing."

The following procedure assumes that you have completed the installation procedure described in the previous section, "Installing a Windows 98 Dial-Up Server."

► **To configure the dial-up server for user-level security**

1. Make sure that your computer has file and printer sharing services installed and that user-level security is enabled. For more information, see Chapter 18, "Logon, Browsing, and Resource Sharing."
2. In Dial-Up Networking, click the **Connections** menu, and then click **Dial-Up Server**.
3. In the **Dial-Up Server** properties, click **Allow caller access**, and then click **Add**.
4. In the **Add Users** dialog box, specify the users who will have permission to access the dial-up server, and then click **OK**.
5. In the **Dial-Up Server** properties, click **Server Type**, and make sure **Require encrypted password** is checked if your Dial-Up client supports encrypted passwords.

Clicking the **Require encrypted password** option requires the client to send an encrypted as opposed to a text password. Some clients support only text passwords; however, encrypted passwords are preferred. Clearing this option does not disable password protection.

► **To configure the dial-up server for share-level security**

1. Make sure that your computer has File and Printer Sharing services installed and that share-level security is enabled. For more information, see Chapter 18, "Logon, Browsing, and Resource Sharing."

Note Share-level security is not available on NetWare networks.

2. In Dial-Up Networking, click the **Connections** menu, and then click **Dial-Up Server**.
3. In the **Dial-Up Server** dialog box, click **Allow caller access**, and then click **Change Password** to provide password protection for the Dial-Up Server.
4. Optionally, to require password encryption, click **Server Type**. In the **Server Type** dialog box, make sure **Require encrypted password** is checked, and then click **OK**.

Configuring the Server Type for the Dial-Up Server

This section explains how to configure the server type for the dial-up server. It assumes that you have already followed the procedures in the sections "Installing a Windows 98 Dial-Up Server" and "Configuring Security Options for a Windows 98 Dial-Up Server," earlier in this chapter.

► **To configure a computer as a dial-up server**

1. From the **Connections** menu in the Dial-Up Networking folder, click **Dial-Up Server**.
2. Click **Server Type**, and then select the server type.

Make sure that the server type is the same for both the dial-up server and the dial-up client. If the dial-up client uses PPP, you can also select the Default server type. If you select the Default server type, the dial-up server will automatically start in PPP mode for incoming calls and switch to Windows for Workgroups and Windows NT 3.1 if the PPP negotiation fails.

3. Click **OK**, and the dial-up server is ready to answer incoming calls.

Notice that changes to the server type do not apply to a currently open connection. Changes will apply to any future connections made to this computer.

Disabling Dial-Up Server Support

You can disable dial-up server support in several different ways. You can disable it from within Dial-Up Networking, as the following procedure explains.

► **To disable the dial-up server on a single computer**

1. From the **Connections** menu in the Dial-Up Networking window, click **Dial-Up Server**.
2. In the **Dial-Up Server** dialog box, click **No caller access**.

You can also completely remove Dial-Up Server capabilities from a user's computer by using the Add/Remove Programs option in Control Panel.

Finally, you can disable dial-up support on each computer or on a system-wide basis by using System Policy Editor to change a single computer's registry or to define policies that can be shared by multiple computers.

To disable dial-up support by using System Policy Editor, click **Disable Dial-in**. The **Dial-Up Server** menu option still appears on the **Connections** menu after dial-up support has been disabled, but no dialog box for setting up the dial-up server will appear. For more information, see Chapter 8, "System Policies."

Configuring and Connecting to Remote Servers

With Dial-Up Networking, you can connect to many different kinds of servers. This section discusses how to connect to and configure a Windows NT Remote Access Server and a Novell NetWare Connect 1.0 or 1.1 server. It also provides technical information about PPP-compatible servers.

Connecting to a Windows NT Remote Access Server

Connecting to a Windows NT remote access server is the same as connecting to a Windows 98 Dial-Up Networking server. All you need is the telephone number of the Windows NT server when creating a connection. Dial-Up Networking negotiates the proper protocols and server connection type. You do not need to specify a default server type.

Planning the Connection to a Windows NT Remote Access Server

Windows NT Server 3.5 and later remote access servers support PPP and RAS clients. PPP is the recommended protocol. Windows NT Server 3.5 and later support IPX/SPX, NetBEUI, and TCP/IP network protocols and can function simultaneously as a NetBIOS gateway, IPX router, and IP router. Windows NT Server 4.0 and later can act as a VPN server, so you can set up a VPN connection to Windows NT 4.0 RAS servers using the PPTP protocol.

Note Windows NT 3.1 supports only the RAS protocol, which is a proprietary protocol that supports only NetBEUI. It is a fast connection type but does not allow for multiple protocols over the connection. RAS in Windows NT 3.1 cannot support the IPX/SPX or TCP/IP protocols.

Microsoft recommends that you upgrade from Windows NT RAS to Windows NT Server 3.5 or later, which provides many additional benefits, including PPP support.

A Windows NT 3.5 or later remote access server provides several features that a Dial-Up Networking server does not. For an explanation of these differences, see "Configuring and Using the Windows 98 Dial-Up Server" earlier in this chapter.

For more information about Windows NT remote access servers, see the *Microsoft Windows NT Server Networking Guide* in the *Microsoft Windows NT Server Resource Kit* (for Microsoft Windows NT Server version 4.0). See also the *Networking Supplement* for Windows NT Server version 4.0.

Configuring a Windows NT Server for Windows 98 Dial-Up Clients

To configure a computer running Windows NT Server 3.5 or later so that Windows 98 dial-up clients can remotely access it, you need to install and configure RAS.

You must be logged on as a member of the Administrators group to install and configure RAS. It can be installed during Custom Setup of Windows NT or afterward. During Express Setup, if there is not a network adapter in a computer, you are given the option to install RAS.

RAS installation varies slightly depending on which network protocols are installed. If you use TCP/IP or IPX/SPX protocol with RAS, you should install the protocol before you install RAS, although selecting a protocol that is not installed causes that protocol to be installed at the conclusion of RAS Setup. For information about installing either protocol, see the *Networking Supplement* for Microsoft Windows NT Server 4.0.

For information about installing RAS, see the *Microsoft Windows NT Server Resource Kit* (for Microsoft Windows NT version 4.0).

Note Microsoft does not recommend granting guest accounts dial-in permission. If you do, be sure to assign a password to the guest account.

Connecting to a Novell NetWare Connect 1.0 or 1.1 Server

Windows 98 Dial-Up Networking supports connecting to Novell NetWare resources in three ways:

- Connecting directly to a Novell NetWare Connect 1.0 or 1.1 server.
- Connecting directly to a Novell NetWare Connect 2.0 server. NetWare Connect 2.0 uses the PPP protocol, so you can connect to a NetWare Connect 2.0 server as you would to any other PPP server.
- Using a computer running Windows 98 or Windows NT 3.5 or later as a gateway into a network where NetWare servers are connected.

NetWare Connect 1.0 or 1.1 allows a Windows 98 client to dial in to a NetWare server running NetWare Connect 1.0 or 1.1

Note Windows 98 can act only as a client for connecting to a NetWare Connect 1.0 or 1.1 server. NetWare Connect 1.0 or 1.1 clients themselves cannot dial up a Windows 98 dial-up server.

The NetWare Connect 1.0 or 1.1 connection type allows a Windows 98 client to connect directly to a NetWare Connect 1.0 or 1.1 server and to connect to NetWare servers on the connected network.

To use Dial-Up Networking to connect to a NetWare Connect 1.0 server, you must specify NetWare Connect 1.0 as the server type in the properties for a Dial-Up Networking connection. You also need to use the Network option in Control Panel to make sure the following are enabled on a Windows 98 dial-up client or server:

- Microsoft Client for NetWare Networks.
- The IPX/SPX-compatible protocol bound to the Microsoft Dial-Up adapter driver.

If you use Dial-Up Networking to access NetWare Connect 1.0 or 1.1 servers, you can access data remotely, but you cannot control a computer remotely as you can with the NetWare Connect 1.0 or 1.1 client software supplied by Novell.

Technical Notes for PPP-Compatible Servers

This section provides technical information about connecting to PPP-compatible servers. It covers the following topics:

- PPP architecture
- PPP dial-up sequence
- PPP log file

PPP Architecture

The Point-to-Point Protocol (PPP) provides a standard method for transporting multi-protocol datagrams over point-to-point links. PPP does so by establishing and configuring different link and network-layer protocols to carry traffic from point to point. Control and data flow modules make up the PPP control protocols as illustrated in Figure 19.5.

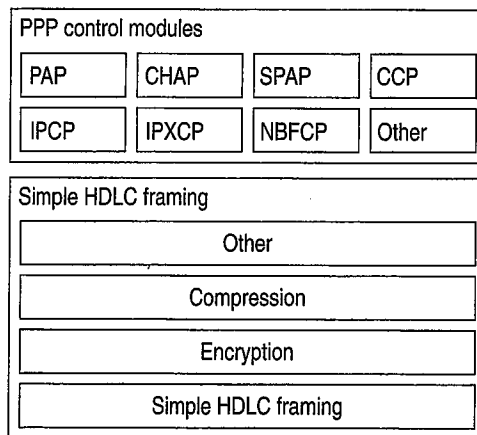

Figure 19.5 Microsoft PPP control modules

Figure 19.5 shows Password Authentication Protocol (PAP), Challenge Handshake Authentication (CHAP), and Shiva Password Authentication Protocol (SPAP), which perform password authentication of PPP clients. Compression Control Protocol (CCP) is used to negotiate encryption with PPP clients. IPCP, IPXCP, NBFCP, and Other are the Internet Protocol (IP), NetWare IPX, NetBIOS Extended User Interface (NetBEUI), and Other protocol modules, respectively, which control PPP client sessions. *HDLC* is the High-level Data Link Control protocol.

PPP Dial-Up Sequence

When a user dials in to a PPP-compatible server, four things happen:

1. The Data Link Control Layer (HDLC) defines how data is encapsulated before transmission on the WAN. By providing a standard framing format, PPP ensures that various vendors' remote access solutions can communicate and distinguish data packets from each other. PPP uses HDLC framing for serial, ISDN, and X.25 data transfer.

The PPP Data Link Control layer is a slightly modified version of the HDLC layer. The HDLC format, extensively used by IBM and others for synchronous data transfer, was modified by adding a 16-bit protocol field that allows PPP to multiplex traffic for several Network Control Protocol (NCP) layers. This encapsulation frame has a 16-bit checksum, but the size of the protocol field and address can be compressed.

2. Link Control Protocol (LCP) establishes, configures, and tests the integrity of the data-link connection. LCP also negotiates which authentication protocol (listed in step 3) will be used. When LCP negotiates authentication of protocols, it determines what level of security validation the remote access server can perform and what the server requires. LCP also determines whether Multilink will be used.
3. The authentication protocol negotiated by LCP is used. Any of the following authentication protocols can be used.
 - PAP uses a two-way handshake for the peer to establish its identity. This handshake occurs only when the link is initially established. With PAP, passwords are sent over the circuit in text format, which offers no protection from playback.
 - SPAP offers encryption of PAP passwords and Novell NetWare bindery access for user account information. When Windows 98 is set up for user-level security using a NetWare server account list, this is the security type used for remote access clients.
 - CHAP periodically verifies the identity of the peer, using a three-way handshake. The authenticator sends a challenge message to the peer. The peer returns the user name and an MD5 hash of the challenge, session ID, and client's password. The authenticator then checks this response and, if the values match, the authentication is acknowledged; otherwise, the connection is ended. CHAP provides protection against playback attack, because the challenge value changes with every message. Because the password is never sent unencrypted over the link, it is virtually impossible to learn it.

- MS-CHAP is an encrypted authentication mechanism similar to but more secure than CHAP. As with CHAP, the authenticator sends a challenge to the peer. The peer must return the user name and an MD4 hash of the challenge string, the session ID, and the MD4-hashed password. This design, which manipulates a hash of the MD4 hash of the password, provides an additional level of security because it allows the authenticator to store hashed passwords instead of clear-text passwords. MS-CHAP also provides additional error codes, including a password expired code, and additional encrypted client-server messages that permit users to change their passwords. In Microsoft's implementation of MS-CHAP, both the peer and the authenticator independently generate an initial key for subsequent data encryption. During phase 2 of PPP link configuration, the authenticator collects the authentication data and then validates the data against its own user database or against a central authentication database server.
4. After authentication, the client and server begin negotiating NCPs. NCPs establish and configure different network protocol parameters. The type of NCP that PPP selects depends on which protocol (NetBEUI, TCP/IP, or IPX) is being used to establish the Dial-Up Networking connection. Windows 98 supports the following:
- NetBIOS Frames Control Protocol (NBFCP) is used to configure, enable, and disable the NetBEUI protocol modules on both ends of the link. For information about NBFCP, see Request for Comments (RFC) 2097, "The PPP NetBIOS Frames Control Protocol."
 - Internet Protocol Control Protocol (IPCP) is used to configure, enable, and disable IP protocol modules at both ends of the link. IPCP is defined in RFC 1332, "The PPP Internet Protocol Control Protocol (IPCP)"
 - Internet Packet Exchange Control Protocol (IPXCP) is used to configure, enable, and disable IPX protocol modules on both ends of the link. IPXCP is widely implemented by PPP vendors. IPXCP is defined in RFC 1552, "The PPP Internetwork Packet Exchange Protocol (IPXCP)."

PPP Log File

You can record how the PPP layers process a call by enabling the PPP log file. This file contains some of the basic layers and points of any Dial-Up Networking session, and is especially useful for monitoring PPP sessions. It is recorded and stored in the Windows directory.

Windows 98 improves over the PPP logging feature in Windows 95 in a few ways. It allows you to enable PPP logging per connection, rather than per adapter. Thus, you can enable PPP logging for only the connections you need, and you do not need to know which adapter is used for which connection. Also, you do not need to reboot for PPP logging to take effect. Moreover, PPP logging is more sophisticated in Windows 98 than in Windows 95. As the sample at the end of this section shows, with Windows 98, the PPP log shows the actual packets that are being passed.

► **To enable PPP logging for a connection**

1. In Dial-Up Networking, single-click a connection icon, and in the **File** menu, select **Properties**.
2. Click the **Server Types** tab.
3. Select the option named **Record a log file for this connection**.

The following example is sample content of a ppplog.txt file. This is only a partial log of a connection; it stops before authentication. For information about the format of PPP packets, see RFC 1662, "PPP in HDLC-like Framing."

```
03-19-1998 13:17:16.04 - Microsoft Dial Up Adapter log opened.
03-19-1998 13:17:16.04 - Server type is PPP (Point to Point Protocol).
03-19-1998 13:17:16.04 - FSA : Adding Control Protocol 80fd (CCP) to
control protocol chain.
03-19-1998 13:17:16.04 - FSA : Protocol not bound - skipping control
protocol 803f (NBFCP).
03-19-1998 13:17:16.04 - FSA : Adding Control Protocol 8021 (IPCP) to
control protocol chain.
03-19-1998 13:17:16.04 - FSA : Protocol not bound - skipping control
protocol 802b (IPXCP).
03-19-1998 13:17:16.04 - FSA : Adding Control Protocol c029 (CallbackCP)
to control protocol chain.
03-19-1998 13:17:16.04 - FSA : Adding Control Protocol c027 (no
description) to control protocol chain.
03-19-1998 13:17:16.04 - FSA : Encrypted Password required.
03-19-1998 13:17:16.04 - FSA : Adding Control Protocol c223 (CHAP) to
control protocol chain.
03-19-1998 13:17:16.04 - FSA : Adding Control Protocol c021 (LCP) to
control protocol chain.
03-19-1998 13:17:16.04 - LCP : Callback negotiation enabled.
03-19-1998 13:17:16.04 - LCP : Layer started.
```

```
03-19-1998 13:17:16.05 - PPP : Transmitting Control Packet of length: 25
03-19-1998 13:17:16.05 - Data 0000: c0 21 01 01 00 17 02 06 | .!....*..
03-19-1998 13:17:16.05 - Data 0008: 00 0a 00 00 05 06 00 02 | .....
03-19-1998 13:17:16.05 - Data 0010: 50 17 07 02 08 02 0d 03 | P*.....
03-19-1998 13:17:16.05 - Data 0018: 06 00 00 00 00 00 00 00 | .....
03-19-1998 13:17:19.05 - PPP : Transmitting Control Packet of length: 25
03-19-1998 13:17:19.05 - Data 0000: c0 21 01 02 00 17 02 06 | .!....*..
03-19-1998 13:17:19.05 - Data 0008: 00 0a 00 00 05 06 00 02 | .....
03-19-1998 13:17:19.05 - Data 0010: 50 17 07 02 08 02 0d 03 | P*.....
03-19-1998 13:17:19.05 - Data 0018: 06 00 00 00 00 00 00 00 | .....
03-19-1998 13:17:22.05 - PPP : Transmitting Control Packet of length: 25
03-19-1998 13:17:22.05 - Data 0000: c0 21 01 03 00 17 02 06 | .!....*..
03-19-1998 13:17:22.05 - Data 0008: 00 0a 00 00 05 06 00 02 | .....
03-19-1998 13:17:22.05 - Data 0010: 50 17 07 02 08 02 0d 03 | P*.....
03-19-1998 13:17:22.05 - Data 0018: 06 00 00 00 00 00 00 00 | .....
03-19-1998 13:17:22.11 - PPP : Received Control Packet of length: 8
03-19-1998 13:17:22.11 - Data 0000: c0 21 04 03 00 06 08 02 | .!.....
03-19-1998 13:17:22.11 - LCP : Received configure reject for address
field compression option.
03-19-1998 13:17:22.11 - PPP : Transmitting Control Packet of length: 23
03-19-1998 13:17:22.11 - Data 0000: c0 21 01 04 00 15 02 06 | .!....*..
03-19-1998 13:17:22.11 - Data 0008: 00 0a 00 00 05 06 00 02 | .....
03-19-1998 13:17:22.11 - Data 0010: 50 17 07 02 0d 03 06 00 | P*.....
03-19-1998 13:17:22.16 - PPP : Received Control Packet of length: 23
03-19-1998 13:17:22.16 - Data 0000: c0 21 02 04 00 15 02 06 | .!....*..
03-19-1998 13:17:22.16 - Data 0008: 00 0a 00 00 05 06 00 02 | .....
03-19-1998 13:17:22.16 - Data 0010: 50 17 07 02 0d 03 06 00 | P*.....
03-19-1998 13:17:23.27 - PPP : Received Control Packet of length: 32
03-19-1998 13:17:23.27 - Data 0000: c0 21 01 00 00 1e 03 05 | .!....*..
03-19-1998 13:17:23.27 - Data 0008: c2 23 80 05 06 00 00 6e | .#......n
03-19-1998 13:17:23.27 - Data 0010: 21 07 02 11 04 06 4e 13 | !.....N.
03-19-1998 13:17:23.27 - Data 0018: 09 03 00 80 5f e2 d8 a8 | .....
03-19-1998 13:17:23.27 - LCP : Received and accepted authentication
protocol c223 (CHAP).
03-19-1998 13:17:23.27 - LCP : Received and accepted magic number 6e21.
03-19-1998 13:17:23.27 - LCP : Received and accepted protocol field
compression option.
03-19-1998 13:17:23.27 - PPP : Transmitting Control Packet of length: 19
03-19-1998 13:17:23.27 - Data 0000: c0 21 04 00 00 11 11 04 | .!.....
03-19-1998 13:17:23.27 - Data 0008: 06 4e 13 09 03 00 80 5f | .N....._
03-19-1998 13:17:23.27 - Data 0010: e2 d8 a8 00 00 00 00 00 | .....
03-19-1998 13:17:23.30 - PPP : Received Control Packet of length: 19
03-19-1998 13:17:23.30 - Data 0000: c0 21 01 01 00 11 03 05 | .!.....
03-19-1998 13:17:23.30 - Data 0008: c2 23 80 05 06 00 00 6e | .#......n
03-19-1998 13:17:23.30 - Data 0010: 21 07 02 00 00 00 00 00 | !.....
03-19-1998 13:17:23.30 - LCP : Received and accepted authentication
protocol c223 (CHAP).
03-19-1998 13:17:23.30 - LCP : Received and accepted magic number 6e21.
03-19-1998 13:17:23.30 - LCP : Received and accepted protocol field
compression option.
```

```

03-19-1998 13:17:23.30 - PPP : Transmitting Control Packet of length: 19
03-19-1998 13:17:23.30 - Data 0000: c0 21 02 01 00 11 03 05 | .!.....
03-19-1998 13:17:23.30 - Data 0008: c2 23 80 05 06 00 00 6e | .#. ....n
03-19-1998 13:17:23.30 - Data 0010: 21 07 02 00 00 00 00 00 | !.....
03-19-1998 13:17:23.30 - LCP : Layer up.

```

Implementing Virtual Private Networking

Networking provides a way to connect a client computer to a server by means of a transmission medium such as a network wire or a dial-up connection. It contains three key elements: the client, the transmission media, and the server.

Similarly, virtual private networking (VPN) provides a way to connect a client computer to a server by means of a tunnel through an intermediary network. That is, it uses a network as a transmission medium. The virtual private network consists of the two computers (one at each end of the connection) and a route, or *tunnel*, over the public or private network.

For example, suppose you want to access the resources on your corporate LAN, but you have only an Internet connection. With virtual private networking, you can “tunnel through” the Internet to access resources on your corporate LAN.

In another example, suppose you are connected to your corporate LAN (LAN A), but you want to access the resources on a server on another LAN (LAN B). LAN A and LAN B are connected by means of a private TCP/IP network. With virtual private networking, you can tunnel through the private network to access the resources on the server on LAN A just as if you were directly connected to it.

In Windows 98, virtual private networking is implemented using the *Point-to-Point Tunneling Protocol* (PPTP). PPTP allows you to tunnel through TCP/IP-based data networks to securely access resources on remote servers. PPTP supports multiple network protocols (IP, IPX, and NetBEUI) and can be used for virtual private networking over public and private networks. You can use PPTP to provide secure, on-demand, virtual networks by using dial-up lines, LANs, WANs, or the Internet and other public, TCP/IP-based networks.

The networking technology of PPTP is an extension of the remote access PPP protocol defined in the IETF document “The Point-to-Point Protocol” (RFC 1661). PPTP is a network protocol that encapsulates PPP packets into IP datagrams for transmission over the Internet or other public TCP/IP-based networks. PPTP can also be used in private LAN-to-LAN networking.

For more information about virtual private networking, visit Microsoft’s Web site at <http://www.microsoft.com/communications/>. You can also download the IETF Internet draft “Point-to-Point Tunneling Protocol—PPTP” from <http://www.ietf.org/>.

Planning for Virtual Private Networking

There are two common virtual private networking scenarios:

- You can connect your workstation to a remote network by making a Dial-Up Networking connection to a network access server at an ISP facility, and then tunneling through the Internet to a VPN server that is attached to both the Internet and the remote network. Once you are connected to the VPN server, you can transparently gain access to any public or private network that is connected to it.
- If you have a permanent IP connection to a VPN tunnel server (such as a LAN connection), you can use that VPN server to tunnel to any public or private network that is connected to it.

Some less common virtual private networking scenarios require a server provided by a third party. For instance, some VPN tunnel servers, called front end processors (FEPs), can be used for modem pooling. If your PC is on a network with a FEP that has modems available for dialing out, users can simply connect to that tunnel server, dial out, and establish a connection to a PPP access server on another network.

The following section describes the first scenario, in which you use the Internet as the network through which the client tunnels. However, keep in mind that you could use any TCP/IP network in place of the Internet. If so, you must have a permanent TCP/IP connection to a VPN server, and you do not need a dial-up connection to a network access server.

Typical Virtual Private Networking Deployment

A typical deployment of virtual private networking starts with a remote or mobile Windows 98 client that uses a local ISP to access the Internet. The client then tunnels through the Internet to a private enterprise LAN.

A Windows 98 client must make two connections to establish a VPN tunnel: one physical connection and one logical connection. Figure 19.6 shows these connections. The client first uses Dial-Up Networking and the remote access protocol, PPP, to connect to a network access server at an ISP's facility. Once connected, the client can send and receive packets over the Internet. The network access server uses the TCP/IP protocol for all traffic to the Internet.

Note Network access servers are also referred to as dial-in servers, or point-of-presence (POP) servers.

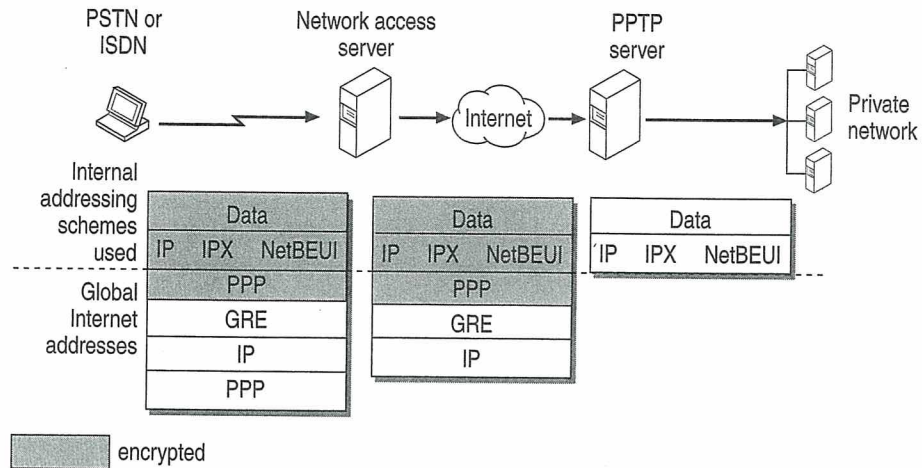

Figure 19.7 Connecting a Dial-Up Networking VPN client to the private network

PPTP encapsulates the encrypted and compressed PPP packets into IP datagrams for transmission over the Internet. The IP datagrams are created using a modified version of the Internet Generic Routing Encapsulation (GRE) protocol. (defined in RFCs 1701 and 1702). These IP datagrams are routed over the Internet until they reach the VPN server that is connected to both the Internet and the private network. The VPN server disassembles the IP datagram into a PPP packet and then decrypts the PPP packet. It then sends the de-encapsulated IP, IPX, or NetBEUI packet on the private network.

Using Network Protocols with Virtual Private Networking

Virtual private networking allows you to create a tunnel over a public TCP/IP network but retain existing network protocols, network node addresses, and naming schemes on the private enterprise network. Thus, no changes to existing network configurations or network-based applications are required when using virtual private networking to tunnel across the Internet or other TCP/IP-based public networks. For example, IPX or NetBEUI clients can continue to run applications on the private network that require these protocols.

Name resolution methods used on the private network—such as Windows Internet Naming Service (WINS) for NetBIOS computers, Domain Name System (DNS) for TCP/IP host names, and Service Advertisement Protocol (SAP) for IPX networking—do not need to be changed.

Note The address and name resolution schemes on the private enterprise network must be correctly configured. If they are not, VPN clients are unable to communicate with computers on the private network.

Virtual Private Networking Issues

Consider the following issues when using virtual private networking:

- A VPN server can be placed behind a firewall on the private enterprise network to ensure that traffic in and out of the private network over the VPN server is secured by the firewall computer. (For more information, visit <http://www.microsoft.com/communications/> and download “Understanding PPTP.”)
- Using the Internet to establish a connection between a VPN client and a VPN server means that the VPN server must have a globally unique IP address that is valid for the global Internet. However, the encapsulated IPX, NetBEUI, or TCP/IP packets sent between the VPN client and the VPN server can be addressed to computers on the private enterprise network using private network addressing or naming schemes. The VPN server disassembles the PPTP packet from the VPN client and forwards the packet to the correct computer on the private network. For more information about private network addressing, see Chapter 15, “Network Adapters and Protocols.”

Configuring Virtual Private Networking

Depending on how you will be using virtual private networking, you will need to configure different types of connections.

If you have a permanent TCP/IP connection (such as a LAN connection) to a VPN tunnel server, and you want to connect to a remote network that is connected to your VPN server, you need only configure the connection to that VPN tunnel server.

If you want to connect your workstation to a remote server by tunneling through the Internet, you must configure two connections: a connection to the Internet through your ISP and a tunnel connection to the VPN server on the target network.

To configure the connection to your ISP or your VPN tunnel server, follow the procedures outlined in “Defining a Dial-Up Networking Connection” and “Configuring and Using Dial-Up Networking Clients” earlier in this chapter.

Using Virtual Private Networking

This section describes how to use the two common VPN configurations.

Note If you are using PPP or PPTP to connect to another IPX network, you will lose IPX connectivity to your local network. Thus, after you make a dial-up or virtual private networking connection, you will no longer be able to see NetWare servers on the local network.

Using Virtual Private Networking over the LAN to Connect to a Tunnel Server

VPN clients with a permanent IP connection to a VPN tunnel server can use VPN tunneling over that IP connection. For example, suppose that you are in a networked office environment and your network has a VPN tunnel server. You can then use that VPN server to tunnel to any private network that is connected to that VPN server, such as the personnel department's private network. Thus, you can create a virtual private network by using your direct LAN connection. Data sent from your VPN client to another computer on the LAN is encrypted and secure because you are using a VPN server to connect to the remote computer.

In the following scenario, the VPN client uses Dial-Up Networking over a LAN connection instead of a telephone line. Only one connection to the VPN server is required.

► **To connect to a VPN server over a LAN connection**

1. Double-click My Computer, and then double-click Dial-up Networking.
2. Click the icon that you have created for your VPN server.
3. Enter the user name and password required for the target network.
4. Click **Connect**.
5. You now have a connection to your VPN server.

Note The connection speed displayed is only an estimate. If you see a connection speed that seems too high or too low it will not impact performance and should not be cause for concern.

After you successfully connect to a VPN server, all traffic from your computer is first routed to your VPN server, which then forwards your data across the LAN to the remote computer. Your computer behaves as if it were physically connected to the remote network. While the tunnel is open, you continue to see computers and servers on your immediate LAN subnet. However, you might not be able to see hosts and servers on other subnets on your LAN. Contact your network administrator for more information.

Dialing an ISP to Connect to a Virtual Private Networking Server

With virtual private networking, you can connect your workstation to a remote network by tunneling through the Internet to a VPN server on that network. To do so, you must make two connections. First, you must connect to the Internet through an ISP. Next, you must create a tunnel to the target network. This section explains how to make these connections.

- ▶ **To connect to the Internet**
 1. In My Computer, double-click Dial-Up Networking.
 2. Double-click the connection icon that was created for your ISP.
 3. In the **Connect To** dialog box that appears, enter the user name and password required by your ISP, and then click **Connect**.

- ▶ **To connect to the target network using a tunnel to the VPN server**
 1. After connecting to your ISP, click the icon that was created for your VPN server.
 2. Enter the user name and password required for the target network.
 3. In the **Connect To** window, click **Connect**.

You now have two connections, as seen in the two following similar boxes.

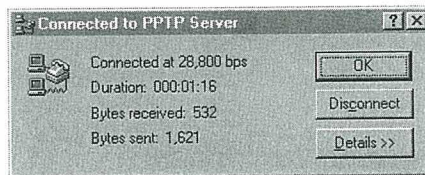
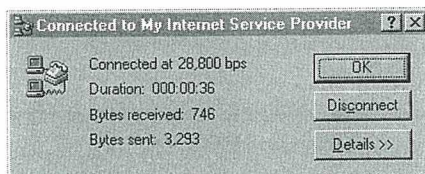

After you connect successfully to the VPN server on the remote network, the ISP routes all traffic sent from your workstation over the Internet to the VPN server. The VPN server then routes the traffic to the correct computer on the remote network. Consequently, you see only computers and servers on the remote network. You no longer see the Internet unless the remote network itself provides access to the Internet.

Virtual Private Networking Security

This section describes VPN security and discusses how to use virtual private networking with firewalls.

Authentication

When you dial an ISP network access server (NAS), the NAS requires require initial dial-in authentication. This authentication is required only to log on to the NAS; it is not related to Windows NT-based authentication. Check with your ISP for their authentication requirements.

When you dial a VPN tunnel server to connect to a private network, the VPN server requires a standard Windows NT-based logon. Therefore, remote access logon using a computer running Windows 98 is as secure as logging on from a Windows-based computer connected to the local LAN.

Authentication of remote VPN clients is performed using the same PPP authentication methods used for any Dial-up Networking client dialing directly to a RAS server. Microsoft's implementation of Dial-up Networking supports the CHAP, MS-CHAP, and PAP authentication schemes.

Access Control

After authentication, all access to a private LAN continues to use the Windows NT-based security model. Access to resources on NTFS drives or to other network resources requires the proper permissions.

For more information about using security on NTFS drives or other network resources, see your product documentation or the *Microsoft Windows NT Server Resource Kit* (for Microsoft Windows NT version 4.0).

Data Encryption

For data encryption, virtual private networking uses the RAS "shared-secret" encryption process. Both the client and the server share a secret, the user's password. Both the client and the server uses the secret to generate an initial 40-bit encryption key, then uses the key to encrypt and decrypt all data that it passes over the Internet. When you are connecting to a Windows NT 4 RAS Server with Service Pack 4 or later, the key changes on every packet. For earlier versions of Windows NT 4, the key changes every 256 packets.

Note The process by which the client and server generate the initial key occurs only when MS-CHAP is used.

Users in the United States and Canada can obtain a 128-bit session key through a cryptography pack for use inside the US. Contact your Microsoft reseller for more information. When 128-bit encryption is used, the initial key is based on the password and a unique MS-CHAP challenge.

PPTP Packet Filtering

To protect the VPN server from malicious attacks, you can enable PPTP filtering on the VPN server. With PPTP filtering, the VPN server on the private network accepts and routes *only* authorized, encrypted PPTP packets from authenticated users.

PPTP filtering is enabled on the VPN server. For step-by-step instruction on enabling PPTP filtering, see the white paper "Installing, Configuring, and Using PPTP with Microsoft Clients and Servers" at <http://www.microsoft.com/communications/>.

Virtual Private Networking with Firewalls and Routers

PPTP traffic uses TCP port 1723, and IP protocol uses ID 47, as assigned by the Internet Assigned Numbers Authority (IANA). Virtual private networking can be used with most firewalls and routers by enabling traffic destined for TCP port 1723 and protocol 47 to be routed through the firewall or router.

Firewalls ensure corporate network security by strictly regulating data that comes *into* the private network from the Internet. An organization can deploy a VPN server running Windows NT Server 4.0 behind its firewall. The VPN server accepts PPTP packets passed to the private network from the firewall and extracts the PPP packet from the IP datagram, decrypts the packet, and forwards the packet to the computer on the private network.

Technical Notes on Dial-Up and Virtual Private Networking

In Windows 98, computers can be *multihomed*, or configured with multiple IP addresses. This enables them to connect to multiple networks that are physically separate, such as a corporate network and the Internet, with certain limitations. This section describes those limitations as they apply to Dial-Up Networking. For general information about multihoming, see Chapter 15, "Network Adapters and Protocols."

If you are connected to a LAN and you make a PPP dial-up connection or a VPN connection, you might lose connectivity to some of the servers on your LAN. Likewise, if you connect to the Internet, then make a VPN connection to another network, you might lose connectivity to the Internet itself.

This is because of the default routing changes that Dial-up Networking makes when setting up a connection. Clients on TCP/IP networks can send packets directly to hosts on their immediate network segment. However, to reach other network segments and other networks, they send their packets to a default gateway instead. That gateway then determines where to send the packets. Thus, clients can send packets to servers anywhere in a very large, complex network without having to know how to reach each server. Figure 19.8 shows how TCP/IP clients use default gateways.

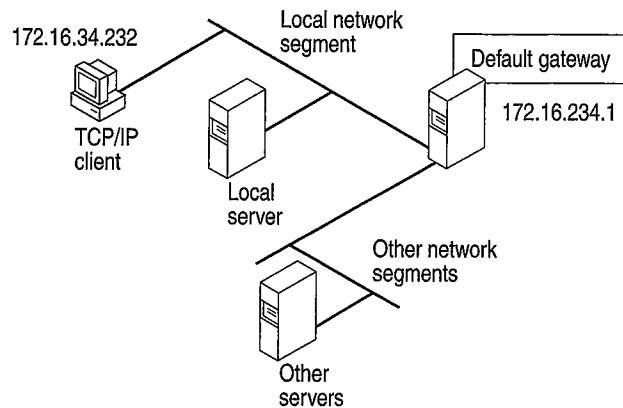

Figure 19.8 Default gateway for a TCP/IP client

You can find out what your default gateway is by looking at the route table for your computer. The *route table* shows all the routes your computer uses to reach other computers on the network.

For more information about the route table and to see the complete route table for the network shown in Figure 19.8, see Chapter 15, “Network Adapters and Protocols.”

▼ **To view the route table**

- At the command prompt, type **route print**.

Table 19.2 shows a partial route table for the network shown in Figure 19.8.

Table 19.2 Partial route table for TCP/IP client

| Network address | Netmask | Gateway address | Interface | Metric |
|-----------------|---------|-----------------|---------------|--------|
| 0.0.0.0 | 0.0.0.0 | 172.16.34.1 | 172.16.34.232 | 1 |
| ... | ... | ... | ... | ... |

Notice that the first line of the route table shows the address for the default gateway, and that it has a metric of 1. The *metric* indicates which gateway will be used and what the gateways that will be used if the first is removed from the route table. TCP/IP clients always use the default gateway with the smallest metric.

TCP/IP clients can be configured with several different default gateways. If one default gateway fails, the clients automatically switch to another. However, because TCP/IP clients always use the default gateway with the smallest metric, they cannot use more than one default gateway at a time.

Figure 19.9 shows what happens when you make a PPP dial-up connection to the Internet. Dial-Up Networking assigns a new default gateway, that of the PPP server. Because the client can use only one default gateway, it sends all network traffic through that gateway. You can no longer gain access to some of the servers on your LAN.

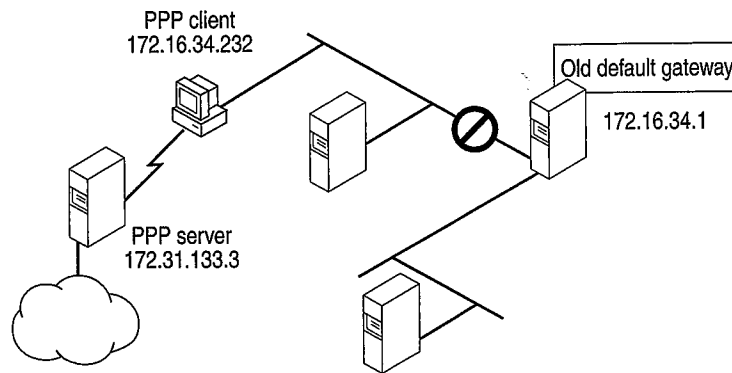

Figure 19.9 New default gateway for PPP client

The partial route table displayed in Table 19.3 shows what happens to the default gateway.

Table 19.3 New partial route table for PPP client

| Network address | Netmask | Gateway address | Interface | Metric |
|-----------------|---------|-----------------|---------------|--------|
| 0.0.0.0 | 0.0.0.0 | 172.16.34.232 | 172.16.34.232 | 1 |
| 0.0.0.0 | 0.0.0.0 | 172.16.34.1 | 172.16.34.232 | 2 |
| ... | ... | ... | ... | ... |

The first line now shows the new default gateway for the PPP server, and the second line shows the old default gateway on your LAN. Because the old default gateway has a metric of 2, the TCP/IP stack does not use it.

If you need to reach servers on your network while connected to the Internet, you can manually add host routes to those servers. Use the **route** command to add a route manually to the gateway, IP subnet, or IP network you want to reach. For more information about adding routes, see Chapter 15, "Network Adapters and Protocols." See also the *Windows NT Server Networking Guide for Windows NT version 4.0*.

Finally, Figure 19.10 shows what happens when you make a VPN tunnel connection over the PPP connection. (For more information about PPP, see "Implementing Virtual Private Networking" earlier in this chapter.) Dial-Up Networking assigns a third default gateway to the VPN server, invalidating the first two default gateways. You lose access not only to servers on your LAN but to hosts on the Internet.

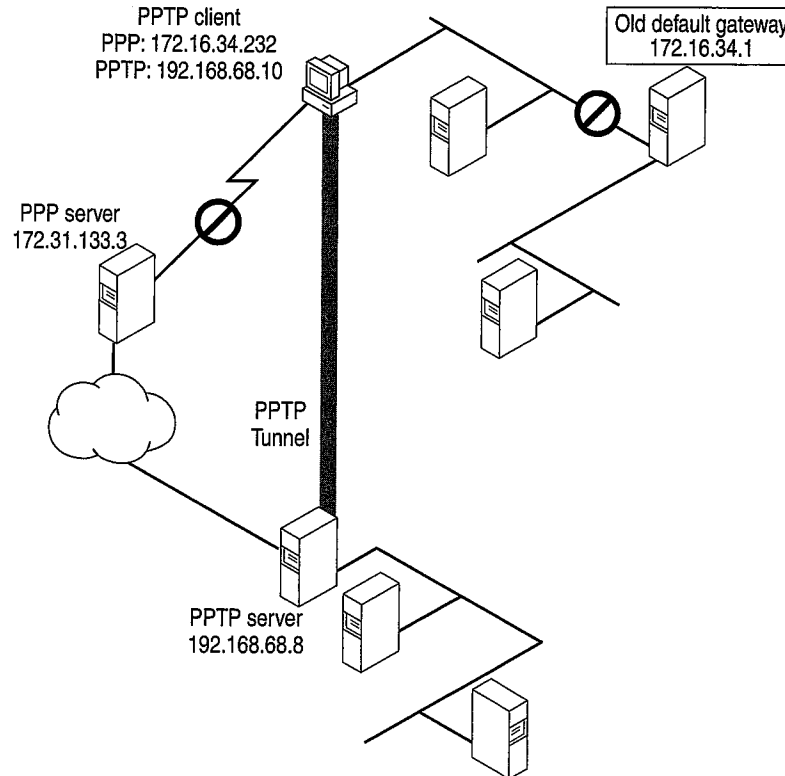

Figure 19.10 New default gateway for PPTP client

The partial route table displayed in Table 19.4 shows the default gateways.

Table 19.4 New partial route table for VPN client

| Network address | Netmask | Gateway address | Interface | Metric |
|-----------------|---------|-----------------|----------------|--------|
| 0.0.0.0 | 0.0.0.0 | 192.168.68.10 | 192.168.68.10 | 1 |
| 0.0.0.0 | 0.0.0.0 | 172.16.34.232 | 172.16.34.232 | 2 |
| 0.0.0.0 | 0.0.0.0 | 172.20.232.1 | 172.20.234.232 | 2 |
| ... | ... | ... | ... | ... |

If you want to regain lost connectivity to servers on your local network or to the Internet, you have the following options:

- You can manually add host routes to servers on your network, as described in Chapter 15, “Network Adapters and Protocols.”
- For VPN connections, you can disable the default gateway to the VPN tunnel server. You must then add routes to the virtual private network.

The following procedure describes how to disable the default gateway to the VPN tunnel server. After you disable the default gateway, you might need to configure routes to servers on the remote network. However, you do not need to configure a route to the VPN tunnel server, because Dial-Up Networking automatically assigns a host route to that server.

► **To disable the default gateway to the VPN tunnel server**

1. In the Dial-Up Networking folder, right-click the VPN server connection icon, and then click **Properties**.
2. Click the **Server Types** tab.
3. Click **TCP/IP Settings**.
4. Clear the **Use default gateway on remote networks** check box.

Dial-up Networking automatically creates a host route to the VPN tunnel server, so you can still reach it.

Using Windows 98 Mobile Computing Features

You can be productive away from the office by using the following Windows 98 mobile computing tools:

Windows 98 Briefcase Briefcase allows you to update documents on a portable computer with source documents on a desktop computer or network, thus minimizing the task of keeping track of the relationships between files on a portable computer and on a desktop computer. With Briefcase, you can simultaneously update related files.

Direct Cable Connection Direct Cable Connection (DCC) allows you to establish a connection between two computers quickly and easily by using a parallel cable, a null-modem serial cable, or an infrared connection. After the connection is established, Direct Cable Connection facilitates the transfer of files from the host computer to the guest computer. The host can act as a gateway to an IPX/SPX or NetBEUI network for the guest.

Infrared Windows 98 supports infrared devices, so you can wirelessly connect a laptop or a computer to infrared cameras, other computers, or printers. Infrared works with file sharing tools such as Direct Cable Connection, so you can quickly and easily take a laptop with you wherever you go and then update files on a standalone computer or the network.

Deferred printing Windows 98 supports deferred printing, which allows you to generate print jobs when you are not connected physically to a printer. The print jobs are stored until a printer becomes available. Windows 98 detects the printer connection and automatically spools the print jobs in the background. For information, see Chapter 11, "Printing, Imaging, and Fonts."

Internet Mail and News With Outlook Express, you can dial into your internet service provider and download your e-mail from an IMAP4 or POP3 server. You can also download news from your newsgroups located on an NNTP server. For information, see Chapter 22, "Electronic Mail with Outlook Express."

Other mobile computing tools, such as the following, help you manage a portable computer's limited battery power and disk space:

- With Advanced Power Management, you can use the battery indicator on the taskbar and a **Suspend** command on the **Start** menu to save power without turning off your computer. For more information, see Chapter 30, "Hardware Management."
- With DriveSpace, you can free space on their portable computer's hard disk drive and floppy disks by compressing them. For more information, see Chapter 10, "Disks and File Systems."
- With Outlook Express, you can view the headers of mail messages before deciding whether to download, preventing unnecessary messages from taking up disk space.
- With Quick View, you can view the contents of a file in Windows Explorer by right-clicking a file icon. For information, see Chapter 25, "Application Support."

Using Direct Cable Connection

With Direct Cable Connection, you can establish a direct serial connection, parallel cable connection, or infrared connection between two computers in order to share the resources of the computer designated as the host. If the host is connected to a network, the guest computer can also access the network.

For example, if you have a portable computer, you can use a cable to connect it to your work computer and network. To establish a local connection between two computers, you must connect a compatible serial or null-modem parallel cable to both computers, or both computers must be equipped with infrared devices. For information about using Direct Cable Connection with infrared devices, see the section "Using Infrared" later in this chapter.

Before you can transfer files from the host to the guest computer, the files must be in a shared directory, and File and Printer Sharing services for either Microsoft or NetWare networks must be enabled in the Network option in Control Panel. You can also apply share-level security to the shared files. For information, see Chapter 18, "Logon, Browsing, and Resource Sharing," and Chapter 9, "Security."

Before you install and configure Direct Cable Connection, you need to decide:

- What remote access and network protocols do you need to install on the guest and host computers? They must both be running at least one common network protocol in order to connect. A broadcast protocol such as NetBEUI is simplest.
- Do you want the host computer to act as a gateway to a TCP/IP network? If so, you must install NetBEUI.
- What kind of cable or infrared device do you need?
- Do you want to assign a password to the host computer? If you assign a password on the host, all users connecting from the guest computer will be prompted for it. After connecting, the guest can access resources on the host computer according to the type of security applied to it, that is, user-level or share-level security.

Note You cannot use Direct Cable Connection and Dial-Up Networking at the same time. Both applications use the same network interface (Pppmac.vxd). Before using Direct Cable Connection, make sure to shut down any active Dial-Up Networking connections.

Installing and Configuring Direct Cable Connection

To install Direct Cable Connection during Windows 98 Setup, you must run Setup from the DOS prompt and choose Custom or Portable as the setup type. You can also install Direct Cable Connection after installing Windows 98.

▶ To install Direct Cable Connection after Windows 98 Setup

1. In Control Panel, click Add/Remove Programs, and then click the **Windows Setup** tab.
2. In the **Components** list, click **Communications**, and then click **Details**.
3. In the **Components** dialog box, click **Direct Cable Connection**, and then click **OK**.

Windows 98 provides a Direct Cable Connection Wizard for establishing the connection between two computers. The wizard runs when you open Direct Cable Connection the first time. It allows you to designate one computer as the guest and the other as a host. Before you run the wizard, you must install Direct Cable Connection on each computer and connect them with a null-modem serial or parallel cable, or with an infrared device.

For more information about setting up and using Direct Cable Connection, see Help, or the Networks troubleshooter section on "I am unable to connect my Windows 95 computer to my Windows 98 computer."

Cables Compatible with Direct Cable Connection

Windows 98 supports a serial null-modem standard (RS-232) cable and the following parallel cables:

- Standard or Basic 4-bit cable, including LapLink and InterLink cables available before 1992.
- Extended Capabilities Port (ECP) cable. This type of cable works on a computer with ECP-enabled parallel ports, which must be enabled in BIOS. This kind of parallel cable allows data to be transferred more quickly than a standard cable.
- Universal Cable Module (UCM) cable. This cable supports connecting different types of parallel ports. Using this cable between two ECP-enabled ports allows the fastest possible data transfer between two computers.

Parallel cables transmit data simultaneously over multiple lines, whereas serial cables transmit data sequentially over one pair of wires. Thus, parallel cables are faster than serial cables.

You can also use Direct Cable Connection over an infrared link. For more information, see "Using Infrared" later in this chapter.

Using Briefcase to Synchronize Files

If you can use a portable computer and a desktop computer, or you are connected to a network, you must constantly work to keep the files synchronized. Windows 98 Briefcase minimizes this task by keeping track of the relationships between files on two or more computers.

With Briefcase, you can do the following:

- Create a Briefcase folder.
- Add files to Briefcase.
- Check the status of files in Briefcase and their related files.
- Update related files, either individually or all at once.
- Split related files to maintain them separately.

Windows 98 provides a set of OLE interfaces that allow applications to bind reconciliation handlers to it, track the contents of Briefcase, and define the outcome of any reconciliation on a class-by-class basis. For example, when both the file in Briefcase and its synchronized copy outside have changed, Windows 98 calls the appropriate reconciliation handler to merge the two files. This could be handy when several users are simultaneously updating one large document.

Caution Do not place one Briefcase inside another Briefcase. You cannot drag a file into a Briefcase that is in another Briefcase.

Creating and Configuring a Briefcase

To install Briefcase during Windows 98 Setup, you must run Setup from the DOS prompt and choose Custom or Portable as the setup type. You can also install Briefcase after installing Windows 98.

► **To install Briefcase after Windows 98 installation**

1. In Control Panel, double-click Add/Remove Programs.
2. Click the **Windows Setup** tab, in the **Components** list click **Accessories**, and then click **Details**.
3. In the **Accessories** dialog box, click **Briefcase**, and then click **OK**.

If you install Briefcase, it appears as an icon on your Windows 98 desktop. To run Briefcase, double-click its icon.

► **To uninstall Briefcase**

- Drag the Briefcase icon to the Recycle bin.

Tip You can use Briefcase to synchronize files between a portable computer running Windows 98 and a desktop computer running Windows NT Server 3.5 or later.

Updating Files with Briefcase

When you update files by using Briefcase, Windows 98 automatically replaces unmodified files with modified files. If both files have changed, Windows 98 calls the appropriate application (if available) to merge the disparate files. The host and guest can be connected in the following ways:

- You can copy files from your desktop to Briefcase and then load Briefcase onto your portable computer. If you are using a Plug and Play BIOS docking station, Briefcase automatically updates files when you later dock your portable computer.
- You can update files using Briefcase and a floppy disk. For information, see Windows 98 Help.
- You can synchronize files between a portable computer and a network if the portable computer has a network connection.
- You can use Direct Cable Connection to connect two computers running Windows 98, and then use Briefcase to synchronize their files. For more information about Direct Cable Connection, see "Using Direct Cable Connection" earlier in this chapter.

For more information about Briefcase, and for instructions for using Briefcase to update two connected computers, see Help.

Tip To find the copy of a file that is outside Briefcase, click **Find Original** in the **Update Status** dialog box.

Using Infrared

Windows 98 includes Microsoft Infrared version 3.0, which allows you to use infrared devices to connect to computers, printers, or other devices such as infrared cameras. Microsoft Infrared 3.0 supports the Infrared Data Association (IrDA) standards IrDA 1.0, for Serial Infrared Devices (SIR); and IrDA 1.1, for Fast Infrared Devices (FIR). Because of its low cost and simple implementation, infrared is the first widely used wireless transmission technology. It can be used for the following purposes:

- Exchanging files wirelessly between two computers.
- Printing wirelessly on infrared-capable printers.

- Connecting to the network wirelessly instead of using cabling, through a computer connected by Direct Cable Connect.

The Windows 98 implementation of Infrared provides the following benefits:

- Device drivers for SIR devices capable of sending and receiving at speeds up to 115.2 kbps.
- Support for FIR devices capable of sending and receiving data at 4 Mbps.

Windows 98 also includes Microsoft Infrared Transfer, an application that enables a suitably enabled computer to quickly send files using their infrared device.

Installing an Infrared Device

This section describes how to install infrared devices.

Note If you change the infrared adapter model that is connected to the computer, you should reinstall it.

The procedure for installing an infrared device varies depending on whether it is a Plug and Play device. All Fast Infrared devices are Plug and Play-compatible.

► **To install a Plug and Play device**

1. If it is an external device, attach it. The Infrared 3.0 software loads automatically.
2. Double-click the Infrared icon in Control Panel to activate the infrared device. If there is no Infrared icon in Control Panel, press F5 to make the icon appear.

► **To install a non-Plug and Play infrared device**

1. If it is an external device, attach it.
2. In Control Panel, double-click the Add New Hardware wizard. Follow the instructions on the screen, making the following choices:
 - If asked whether the device you want is in the list, click **No**.
 - When asked whether you want Windows to search for your new hardware, click **No**.
 - When the **Hardware Types** box appears, click **Infrared devices**.
 - When asked to select a device, accept the default selection **Generic Infrared Serial Port or dongle**. (The other devices listed are Plug and Play devices.)
 - When asked for such information as the communications port that the infrared device is physically connected to, if you are not sure, accept the defaults.

Using the Infrared Monitor

You can use the Infrared Monitor to keep track of your computer's infrared activity. You can activate Infrared Monitor once your infrared device is installed by double-clicking the Infrared icon in Control Panel or by clicking the animated Infrared icon in the system tray on the Taskbar. The Infrared Monitor contains the tabs and options shown in Table 19.5.

Table 19.5 Infrared Monitor tabs

| Tab name | Tab option | Description |
|----------------|--|---|
| Status | | Tells you whether infrared is working properly and displays information about the infrared connections. |
| Options | Enable infrared communication | Enables and disables infrared services on the physical serial port. |
| | Search for and provide status for devices in range | Starts and stops the infrared device's ability to detect other devices that are in range. |
| | Enable software install for Plug and Play devices in range | Enables and disables Microsoft Infrared Support software from automatically configuring a device across the infrared communication link when the computer comes into range of a new Plug and Play device. |
| | Limit connection speed | Configures the maximum speed for the infrared. Limiting this speed may improve communication. |
| | Restore defaults | Restores settings to defaults. |
| Preferences | Display the infrared icon in the taskbar | Determines whether the infrared icon displays in the system tray. |
| | Open Infrared Monitor for interrupted communication | Specifies whether to open the Infrared Monitor when infrared communication is interrupted. |
| | Play sounds for devices in range and interrupted communication | Specifies whether sounds will be played for various infrared events. |
| Identification | Computer name | Contains the name assigned to the computer. This is the same name used to identify your computer on the network. If no name appears here, enter one. |
| | Computer description | Contains a description of the computer. This is the same description used to identify your computer on the network. If no description appears here, enter one. |

▶ **To verify your connection using Infrared Monitor**

1. On one of the computers, in the system tray on the Taskbar, double-click the animated infrared icon. Infrared Monitor appears.
2. Click the **Status** tab. It shows all devices visible to the computer.
3. Repeat steps 1 and 2 for the other computer.

Transferring Files Using Infrared Transfer

Windows 98 includes Infrared Transfer, a new application for transferring files through an infrared connection.

When an infrared device has been installed, an icon called Infrared Recipient is added to My Computer, and a shortcut to it is added to the **\Windows\Send To** folder. This shortcut adds an item to the **Send To** menu option that appears when you right-click a file or folder.

The first time Infrared Transfer is used to send a file or folder, a folder called My Received Files is created, and all sent files or folders will be copied to this folder. If a file or folder is sent that already exists in the My Received Files folder, a copy of the file or folder is made.

You can transfer files using one of several different methods. Before attempting to transfer files, make sure the infrared communications driver is properly installed and the infrared devices are enabled by carrying out the procedures in "Installing an Infrared Device" and "Using the Infrared Monitor" earlier in this chapter.

▶ **To transfer files or folders using Infrared Recipient**

1. In My Computer, double-click Infrared Recipient.
2. Select an available infrared device.
3. Click **Send Files**.
4. Select the files to send.
5. Click **Open**.

▶ **To transfer files or folders using Send To**

1. Select the files you want to send.
2. Right-click the selected files, and then point to **Send To**.
3. Click **Infrared Recipient**.

▶ **To transfer files or folders using Drag and Drop**

1. In My Computer, open Infrared Recipient.
2. If there is more than one infrared device in range, select an available infrared device.
3. In Windows Explorer, select files you want to send.

4. If there is only a single infrared device in range, drag and drop files onto the Infrared Recipient icon in my computer.
- Or-
5. If there is more than one infrared device in range, drag and then drop files onto the computer selected in **Available** devices within range.

Transferring Files using Direct Cable Connection and Infrared

You can use Direct Cable Connection over an infrared link to connect a host and guest computer. This section describes how to transfer files over an infrared link, using Direct Cable Connection. Before transferring files, you must install Direct Cable Connection on both computers by following the procedure outlined in "Using Direct Cable Connection" earlier in this chapter. Both computers must also use a common network protocol; a broadcast protocol such as NetBEUI is easiest to configure.

Additionally, the files must be in a shared directory, and File and Printer Sharing services for either Microsoft or NetWare networks must be enabled in the Network option in Control Panel. You can also apply share-level security to the shared files. For information about File and Printer Sharing, see Chapter 18, "Logon, Browsing, and Resource Sharing." For more information about share-level security, see Chapter 9, "Security."

► **To transfer files using Direct Cable Connection**

1. Make sure the infrared communications driver is properly installed and the infrared devices are enabled by carrying out the procedures in "Installing an Infrared Device" and "Using the Infrared Monitor" earlier in this chapter.
2. On one of the computers, open the Infrared Monitor and click the **Options** tab. It lists the virtual COM port the infrared device uses. Note this information.
3. On the host computer, click **Start**, point to **Accessories**, and then click **Direct Cable Connection**.
4. Follow the steps in the Direct Cable Connection Wizard to set up the host computer.

When the wizard prompts you for it, select the Host option. When the wizard prompts you to choose a port, use the same virtual port you found in Step 2.

The wizard also offers password protection. It is not necessary to establish password protection on the host computer for this test of the infrared link.

When you have finished the wizard, click **Finish**. Direct Cable Connection starts running on the infrared link and displays the following message: "Status: Waiting to connect via Serial cable on Comx," where Comx is the name of the virtual port the infrared link is using.

5. Repeat steps 3 and 4 for the guest computer, except select the Guest option instead of the Host option. When you have finished the wizard, click **Finish**.

The connection is automatically made over the infrared link, and all the shared folders on the host computer are displayed on the guest computer's screen.

When you run Direct Cable Connection to establish the connection between the host and guest computers, the guest computer might display the message "Direct Cable Connection was unable to display shared folders of the host computer" and prompt you to enter the computer name of the host computer. If this happens, check the **Status** tab of the Infrared Monitor interface screen.

If you are working on the guest computer, and you want to copy a shared folder from the host computer to the guest computer, select the folder's icon in the window that displays all the shared folders that are on the host computer, and drag the icon to the desktop.

To work on a shared folder on the host computer without copying it to the guest computer, double-click the folder in the display on the guest computer. Note that if the host computer is connected to a network, the guest computer can reach shared resources on the network through the connection to the host.

Printing with Infrared Transfer

Before attempting to print, make sure the infrared communications driver is properly installed and the infrared devices are enabled by carrying out the procedures in "Installing an Infrared Device" and "Using the Infrared Monitor" earlier in this chapter.

► To print to an Infrared-Capable Printer

1. Make sure the infrared communications driver is installed on the computer.
2. Bring an infrared-enabled printer within range.
3. Your computer might automatically detect and install the printer. If not, make sure the printer driver for the infrared-capable printer is installed on the computer.
4. Try the Print option in a program.

You can make printers without built-in infrared ports infrared-capable by connecting an infrared adapter made for printers into the printer's parallel port. An example of an infrared adapter for printers is the Extended Systems JetEye Infrared Printer Port ESI-9580. If a parallel cable is also used to connect the computer to the infrared printer adapter, you can use either the infrared link or the parallel cable to print. The infrared link is used when you select the virtual parallel port; the cable is used when you select the physical parallel port.

To validate the infrared link to the printer, make sure the correct printer driver is installed for the infrared-capable printer. (Most printers with built-in infrared ports are Plug and Play devices, which are installed automatically.) Then use a program to print over the infrared link.

If the program prints on an infrared-capable printer, the infrared driver installation is validated. If there is trouble printing, see "Troubleshooting Infrared" later in this chapter for more information.

Troubleshooting Remote Networking and Mobile Computing

This section describes problems you may encounter in using Dial-Up Networking, virtual private networking, and Mobile Computing.

Troubleshooting Dial-Up Networking

This section describes problems that you may encounter in using Dial-Up Networking and how to resolve them. Windows 98 provides a troubleshooting aid for Dial-Up Networking in Help. Try using the troubleshooting aid before taking the troubleshooting steps included in this section.

You can monitor any Dial-Up Networking session for possible problems by enabling the Record a Log File option. This produces a Ppplog.txt file in the Windows directory, which you can reference to find out the cause of a problem. For more information, see Knowledge Base Article Q156435, "How to Interpret the Ppplog.txt File."

Dial-Up Networking does not install properly.

If you cancel Setup while Dial-Up Networking is copying files and then restart the computer, you will see an error message stating that the following files are missing:

- Vnetsup.vxd
- Nwlink.vxd
- Nwredir.vxd
- Nscl.vxd
- Vredir.vxd
- Ndis.vxd
- Ndis2sup.vxd
- Vnetbios.vxd

If these files are missing, Dial-Up Networking will not function correctly. You must remove and reinstall Dial-Up Networking.

► **To remove Dial-Up Networking**

1. In Control Panel, click Add/Remove Programs.
2. Remove all Dial-Up Networking components.
3. Restart your computer.

To reinstall Dial-Up Networking, follow the procedures outlined in “Installing Dial-Up Networking” earlier in this chapter.

Caution Never remove Dial-Up Networking components using Network in Control Panel.

Dial-Up Networking cannot find modem.

If you see an error message stating that Dial-Up Networking cannot find the specified modem, check the following:

- Check that the modem is properly installed and configured.
- In Modems in Control Panel, check the **General tab** to make sure it lists your modem.
- Check the connection to make sure the modem you have specified is the modem connected to your computer.

The remote server does not respond.

If you receive an error message that the computer you are connecting to has not responded, check the following items:

- Check your connection to make sure it is configured to use the network protocols used on the remote server.
- If you are using TCP/IP, check your connection to make sure that the network protocols are configured correctly.
- In Control Panel, check the Network option to make sure it lists all the network protocols used on the remote server.
- Check your connection to make sure it is configured to access the correct server type.
- Check that the server is configured correctly.
- If a terminal logon is required, check that you have configured the **Options** tab in your connection to bring up a terminal window before dialing.

You cannot access the Dial-Up Networking server because a user name is not valid.

In the properties for the Windows 95 or Windows 98 dial-up server, verify that the user name is in the list of users that are allowed access.

▶ To set Dial-Up Networking Server to allow caller access options

1. In Dial-Up Networking, click the **Connections** menu, and then click **Dial-Up Server**.
2. In the **Dial-Up Server** properties, click **Allow Caller Access**, if this is not already selected, and then view the User name list to ensure the user's name appears.

The User name list appears only if you have chosen user-level security for the dial-up server. The type of security is selected in the Network option in Control Panel.

If the dial-up client is also running File and Printer Services for NetWare Networks, the File and Printer Sharing service automatically becomes the default server, but it cannot receive the information needed to find the remote servers.

You cannot access remote NetWare servers when making a dial-up connection.

Disable File and Printer Sharing Service for NetWare Networks when you make the dial-up connection.

Software compression does not work.

Check the settings for the dial-up server type and software compression.

▶ To verify dial-up server and compression options in Dial-Up Networking

1. In the **Connections** menu, click **Dial-Up Server**.
2. Click **Server Type** and verify that the correct type of dial-up server is selected.
3. Check that **Enable software compression** is selected. Compression will occur only if the dial-up client and server have enabled it.

The modem is dialing but not connecting.

- Check the modem configuration; change the configuration if necessary.
- Verify all parameters, such as access codes, area code, country code, and dialing properties.
- Try choosing the driver for **Generic Modem Drivers**.
- If you are using an external modem, check the cable and verify that it is connected correctly.
- Check the COM port configuration in Device Manager.

For more information, see the troubleshooting section in Chapter 21, "Modems and Communications Tools."

Dial-Up Networking Server is not answering incoming calls.

- If you are using an external modem, check the cable and verify that it is connected correctly.
- If you are using an internal modem with a nonstandard IRQ selection, use Device Manager to check the IRQ setting for the COM port and change it if necessary.
- Disable **Allow Caller Access** and shut down the computer. Turn off the computer to reset the COM port. If the modem is external, turn off the modem. Turn the computer back on and reconfigure the Dial-Up Networking server, and then try again.
- If these steps fail, disable **Allow Caller Access** and see if any modem software can manually answer the incoming call.
- Try choosing the **Generic Modem Drivers** on the dial-up server.

The password for the Dial-Up Networking server is stored in the Rna.pwl file. However, simply deleting this file or removing and reinstalling Dial-Up Networking may not remove the password. If you set the Dial-Up Networking server to monitor for calls and then delete the Rna.pwl file, the password is not removed, because it is stored in memory. If you shut down Windows 98 at this point, the Rna.pwl file is re-created with the password in memory.

- ▶ **To replace a forgotten password in a Dial-Up Networking server**
 1. Disable **Allow Caller Access**, and then shut down and restart Windows 98.
 2. Delete the Rna.pwl file, and then restart Dial-Up Networking.

Note When you first connect to the Dial-Up Networking server, an error message states that the password file is missing or corrupt for every modem device you have installed. If you have any null modem devices installed (for example, when you run Direct Cable Connection it installs a modem device for every COM and LPT port you have), this error message also appears.

You lose connectivity to servers on your network or to the Internet.

If you are connected to a LAN and you make a PPP or VPN connection, you might lose connectivity to some of the servers on your LAN. Likewise, if you connect to the Internet, then make a VPN connection to another network, you might lose connectivity to the Internet itself. For information about the cause of this problem and its solution, see "Technical Notes on Dial-Up and Virtual Private Networking," earlier in this chapter.

Multilink does not provide additional bandwidth.

- Check that the server you are connecting to supports Multilink.
- Check that you have two modems or a dual-channel ISDN card. If you do not have two modems or a dual-channel ISDN card, you cannot use Multilink.
- Check that your modems are exactly the same speed. Performance degrades if the modems connect at different speeds.
- Check that your modems or ISDN card are configured correctly. For more information about the correct configuration, see Chapter 21, "Modems and Communications Tools."

TAPI codes do not work properly.

If you entered TAPI codes, an area code, or a country code in one connection, but Dial-Up Networking does not use those codes when you use the connection, make sure that all your connections use the TAPI codes.

- ▶ **To verify that all your connections use the TAPI codes**
 1. Right-click each connection icon, and then select **Properties** from the context menu.
 2. In the **General** tab for each connection, check that **Use area code and Dialing Properties** is selected.

Troubleshooting Your Virtual Private Networking Connection

This section describes common virtual private networking problems and explains how to correct them.

Two Dial-Up networking adapters appear in Network in Control Panel.

This is by design. Do not attempt to remove Dial-Up Networking components using Network in Control Panel. If you need to remove virtual private networking, do so using Add/Remove Programs in Control Panel.

You cannot connect to a VPN server.

If you cannot connect to a VPN server, you can begin to diagnose the problem by looking at the status messages that appear when you attempt to make a connection. If the connection is successful, you will see the following messages:

- a message stating that your computer is dialing a server.
- a message that says the server is verifying your name and password.
- a message that says the client is logging on to the network.

If the connection fails before you see the “Verifying name and password” message, you might have a problem with DNS name resolution, or the VPN server might not be responding. If the connection fails before you see the “Verifying name and password” message and gives you the error message that the other computer is not responding, a computer along the way might be filtering out Generic Routing Encapsulation (GRE) packets, which are required for VPN to work.

However, if you do see the message “verifying name and password,” your PPP connection succeeded and PPTP is working, and you probably have a problem with your user name and password.

You can also check the following items.

Verify that you are properly connected to the Internet. Make sure that your Internet connection is working properly.

► **To check that your connection to the Internet is working properly:**

1. Ping a host that you can normally reach using **ping**.

If **ping** succeeds, your Internet connection is working properly.

2. If **ping** does not reach that host, type its IP address.

If **ping** succeeds, you are properly connected to the Internet, but you are not properly connected to your DNS server. You should be able to connect to your VPN server by typing its IP address instead of its host name.

– Or –

If **ping** fails, you might not be connected to the Internet. Contact your ISP.

Ping the VPN server. Ping the host name or IP address of the VPN server.

If you receive a response, you are properly connected to the VPN server, and you might have entered an incorrect user name or password.

If you do not receive a response, the administrator of the VPN server might have turned on PPTP filtering. This prevents you from pinging the VPN server. Contact the administrator of that server.

Check for a firewall. Firewalls sometimes filter out PPTP packets. Contact your ISP and the administrator of your corporate server and ask if they are using a firewall. If they are, request that they pass TCP port 1723 and IP protocol 47 (the GRE protocol).

Because PPTP is a secure protocol, adding TCP port 1723 and IP protocol 47 will not affect the security of the firewall.

Make sure your ISP is not filtering out PPTP. Contact your ISP and ask if it filters out GRE packets. If so, request that it pass GRE protocol 47.

Check for a proxy server. It is not possible to create a VPN tunnel that passes through a proxy server such as a computer running Microsoft Proxy Server. Therefore, if your internal network's proxy server handles all Internet traffic, including PPTP traffic, you will not be able to create a VPN tunnel to access resources on the internal network.

You cannot log on to the target network.

If you can connect to the VPN tunnel server, but you cannot perform a domain logon to the target network, verify that you have configured the connection to your VPN server to allow you to perform a domain logon to the target network.

► **To verify your VPN configuration**

1. In the Dial-Up Networking folder, right-click the icon for your VPN server connection.
2. Click **Properties**.
3. Click the **Server Types** tab.
4. In the **Advanced options** dialog box, make sure the **Log on to the network** check box is selected.

Your VPN connection is slow.

If your VPN connection is slow, follow the procedures outlined below.

- Check your ISP connection.

You might be able to improve your performance by changing settings in your ISP connection. Specifically, you can improve performance by deselecting the option **Log on to network** and by deselecting all network protocols you are not using. To do so, follow the steps outlined in the procedure in the "Configuring Options for the Server to Which You Are Connecting" section earlier in this chapter. For information about other issues you should consider when setting up a connection to the Internet, see "Configuring a Connection to the Internet" earlier in this chapter.

- Check the connection to other Internet sites.

To check the speed of your Internet connection, ping Internet sites you can normally ping. If **ping** shows a response time of more than five seconds, you have a slow Internet connection. Contact your ISP.

- Check the connection to your VPN server.

If you do not have problems with your Internet connection, but the connection to your VPN server is still slow, the VPN server might be overloaded. Contact the administrator of the VPN server.

You cannot connect after disconnecting from a LAN.

If you have a mobile computer that has a directly attached network adapter card that you use to access resources on your corporate network, you might have trouble connecting to some of your network's hosts after disconnecting a mobile computer such as a laptop from your corporate network and then making a VPN connection to your corporate network. This happens because your computer is still forwarding all its network traffic to the network adapter instead of over the VPN connection. To force your computer to forward its network traffic over the VPN connection, disable your network adapter using the following procedure.

► To disable your network adapter

1. In Control Panel, double-click System.
2. Click the **Device Manager** tab.
3. Double-click **Network adapters**.
4. Select your network adapter.
5. Click **Properties**.
6. In the **Device usage** box, select the **Disable in this hardware profile** check box.

If this procedure does not work, but you are using DHCP to automatically assign IP addresses, you can try using `windowsipcfg` to release your IP address. For more information, see Chapter 15, "Network Adapters and Protocols."

► To release your IP address

1. Click **Start**, click **Run**, type `windowsipcfg`, and then press the ENTER key.
2. In the **IP Configuration** dialog box, click **Release All**.

Troubleshooting Direct Cable Connection

This section presents problems that might occur when you are using Direct Cable Connection.

As general troubleshooting steps, verify the following:

- Verify that your cable is properly connected.
- Make sure that you are using a compatible cable, listed in "Using Direct Cable Connection" earlier in this chapter. Make sure that you are not using such devices as gender-benders or devices that convert 25-pin cables to 9-pin cables.
- Check Device Manager to make sure that you do not have an IRQ port conflict.

- Verify that both computers have the same network protocol installed. A broadcast protocol such as NetBEUI is simplest.

You cannot find the host computer.

If you cannot find the host computer using Direct Cable Connection, follow the procedures in “Using Direct Cable Connection” earlier in this chapter to make sure Direct Cable Connection has been installed correctly on the host computer and is working.

If Direct Cable Connection is working properly but you still cannot find the host computer, make sure you have Client for Microsoft Networks is installed. For more information, see Chapter 16, “Windows 98 on Microsoft Networks.”

You can connect to the host computer but you cannot use it as a gateway to the network.

The host computer and guest computer can communicate using the TCP/IP protocol, which is generally installed by default. However, if you want the host computer to act as a gateway to a TCP/IP network, you should make sure that NetBEUI is installed as well. For more information, see Chapter 15, “Network Adapters and Protocols.”

You cannot use Direct Cable Connection with Dial-Up Networking.

Both Dial-Up Networking and Direct Cable Connection use the same network interface (Pppmac.vxd). You cannot have more than one instance of Pppmac.vxd running at one time, so you cannot use both Direct Cable Connection and Dial-Up Networking at the same time. You must close either Direct Cable Connection or Dial-Up Networking.

Troubleshooting Infrared

Following are several factors to check as you begin to troubleshoot your infrared connection:

- Check distance between infrared adapters.
Try moving the devices closer together or farther apart. The devices must be no more than three feet apart, and some devices work best if kept at least six inches apart. Make sure that there are no obstructions between the devices.
- Check alignment between infrared adapters.
Infrared devices produce an “arc” of infrared light. This arc is usually between 15 and 30 degrees. Try realigning the devices so that they fall within this arc.
- Check for interference with infrared transmission.
Direct sunlight contains infrared light and can cause degradation of the infrared signal between devices. If this occurs, try blocking the sunlight or moving the devices closer together.

- Experiment with connection speed.
Use the **Limit Connection Speed To** option in the Infrared Monitor **Options** tab to limit the connection speed to 19.2 kbps. If this is successful, you can experiment with establishing a connection at a higher speed. This is especially important if an infrared adapter is attached to a COM port that is using an 8250 UART instead of a 16550 UART or if the adapter is connected to a relatively slow computer.
- Ensure that application is set to use virtual infrared port.
Ensure that the application you are using is configured for the virtual port, not the physical port that the infrared device is attached to. Keep in mind that, as with all communications and printer ports, only one application can use the virtual port at one time.
- Verify infrared adapter settings.
Open the Infrared Monitor and verify that all settings are correct.
- Verify the physical COM port.
If you select the wrong physical COM port during installation of the infrared communications driver, the infrared device will be unable to discover another infrared device within range. If this happens, put an actively searching infrared device close to the computer's infrared device and reinstall infrared on a different COM port until the infrared device on the computer discovers the nearby infrared device.
- Verify that the infrared adapter has power.
You might need to change the batteries in an infrared adapter or plug the AC power into an infrared adapter.

Troubleshooting General Infrared Problems

This section discusses general problems that might occur when using infrared. For information about specific infrared hardware, see the next section.

Communication over a virtual COM port link is unreliable with printer's infrared adapter in range.

Communication over a virtual COM port link between two computers might not be reliable if a printer's infrared adapter is also within range. You should move the adapter out of range.

Zmodem fails over infrared.

You might experience problems transferring files over an infrared link. If the Zmodem protocol fails with a link speed of 115.2 kbps, use the Infrared Monitor Limit Connection Speed To tab to limit the link speed to 19.2 kbps and then retry the Zmodem file transfer.

Troubleshooting Specific Infrared Hardware

This section discusses common problems you might experience with specific infrared hardware. For information about general problems you might encounter, see the previous section.

The Texas Instruments TravelMate 5000 might communicate over an infrared link only at very low speeds (9600 bps). The Sharp PC 3050 might communicate over an infrared link only at speeds between 9600 bps and 19.2 kbps.

For the Hewlett Packard Omnibook 4000C or the Hewlett Packard Omnibook 600CT, which have built-in infrared ports, you must install a special echo-canceling serial driver in addition to the components that make up the infrared communications driver. The echo-canceling driver, and instructions on how to install it, are available from Hewlett-Packard.

Serial port does not provide sufficient power for Adaptec AIRport 2000.

The Adaptec AIRport 2000 infrared adapter can be powered in three ways: by the serial port, by installed AA batteries, or by an external power supply. In some cases the serial port might not provide sufficient power for the operation of the adapter. This can cause reduced operating range and/or a failure to find another infrared device that is nearby and aligned correctly. If you suspect this problem, connect an AC adapter or add four AA batteries to the battery compartment in the infrared adapter. This will assure sufficient power. In some instances, you might also need to separate the adapter by at least six inches from the other infrared device.

Cannot print from ActiSys 220L infrared adapter.

If an ActiSys 220L infrared adapter is attached to a computer and used to print to a printer that is using an Extended Systems ESI-9580 printer infrared adapter, or a Hewlett Packard DeskJet 340, you must use the **Options** tab in the Infrared Monitor properties to limit the connection speed to 19.2 kbps in order to print successfully. If the infrared devices are allowed to negotiate the connection speed automatically without setting this limit, they will negotiate a higher connection speed, and a program will be unable to print.

Additional Resources

| For more information about | See this resource |
|-----------------------------------|---|
| Internet drafts and RFCs | http://www.ietf.org/ . |
| Virtual private networking | http://www.microsoft.com/communications/ . |
| Windows NT remote access servers | <i>Windows NT Server Networking Guide for Windows NT Server version 4.0</i> and the <i>Networking Supplement</i> for the Windows NT Server 4.0. |