

A REFERENCE BOOK  
FOR THE MECHANICAL ENGINEER, DESIGNER,  
MANUFACTURING ENGINEER, DRAFTSMAN,  
TOOLMAKER, AND MACHINIST

26<sup>th</sup> Edition  
Machinery's  
Handbook

BY ERIK OBERG, FRANKLIN D. JONES,  
HOLBROOK L. HORTON, AND HENRY H. RYFFEL

CHRISTOPHER J. MCCAULEY, EDITOR  
RICCARDO HEALD, ASSOCIATE EDITOR  
MUHAMMED IQBAL HUSSAIN, ASSOCIATE EDITOR

2000  
INDUSTRIAL PRESS INC.  
NEW YORK

COPYRIGHT 1914, 1924, 1928, 1930, 1931, 1934, 1936, 1937, 1939, 1940, 1941, 1942, 1943, 1944, 1945, 1946, 1948, 1950, 1951, 1952, 1953, 1954, 1955, 1956, 1957, © 1959, © 1962, © 1964, © 1966, © 1968, © 1971, © 1974, © 1975, © 1977, © 1979, © 1984, © 1988, © 1992, © 1996, © 1997, © 1998, © 2000 by Industrial Press Inc., New York, NY.

**Library of Congress Cataloging-in-Publication Data**

Oberg, Erik, 1881—1951

Machinery's Handbook.

2640 p.

Includes index.

I. Mechanical engineering—Handbook, manuals, etc.

I. Jones, Franklin Day, 1879-1967

II. Horton, Holbrook Lynedon, 1907-

III. Ryffel, Henry H. 1920- IV. Title.

TJ151.0245 2000 621.8'0212 72-622276

ISBN 0-8311-2625-6 (Thumb Indexed 11.7 x 17.8 cm)

ISBN 0-8311-2635-3 (Thumb Indexed 17.8 x 25.4 cm)

ISBN 0-8311-2666-3 (CD-ROM)

LC card number 72-622276

**INDUSTRIAL PRESS, INC.**

200 Madison Avenue

New York, New York 10016-4078

**MACHINERY'S HANDBOOK**

26th Edition

First Printing

Printed and bound in the United States of America by National Publishing Company, Philadelphia, Pa. All rights reserved. This book or parts thereof may not be reproduced, stored in a retrieval system, or transmitted in any form without permission of the publishers.

**TABLE OF CONTENTS**  
**TOOLING AND TOOLMAKING**

<b>CUTTING TOOLS</b>	<b>FORMING TOOLS</b>
723 Tool Contour	758 Dovetail Forming Tools
723 Terms and Definitions	758 Straight Forming Tools
726 Relief Angles	761 Circular Forming Tools
727 Rake Angles	763 Formulas
728 Nose Radius	764 Circular Tools
729 Chipbreakers	764 Circular Cut-Off Tools
730 Planing Tools	765 Constants for Diameters
730 Indexable Inserts	766 Corrected Diameters
731 Identification System	770 Arrangement of Circular Tools
732 Indexable Insert Tool Holders	<b>MILLING CUTTERS</b>
733 Standard Shank Sizes	771 Selection of Milling Cutters
734 Letter Symbols	771 Number of Teeth
735 Indexable Insert Holders	772 Hand of Milling Cutters
738 Sintered Carbide Blanks	773 Plain Milling Cutters
739 Standard Sizes for Carbide Blanks	774 Side Milling Cutters
741 Style A Carbide Tipped Tools	775 Staggered Teeth, T-Slot Milling Cutters
741 Single-Point, Sintered-Carbide- Tipped Tools	776 Metal Slitting Saws
742 Style B Carbide Tipped Tools	776 Milling Cutter Terms
743 Style C Carbide Tipped Tools	778 Shell Mills
743 Style D Carbide Tipped Tools	779 Multiple- and Two-Flute Single- End Helical End Mills
744 Style E, Carbide Tipped Tools	780 Regular-, Long-, and Extra Long- Length, Mills
744 Standard Styles ER and EL Carbide Tipped Tools	781 Two-Flute, High Helix, Regular-, Long-, and Extra Long-Length, Mills
745 Style F Carbide Tipped Tools	782 Roughing, Single-End End Mills
745 Tool Nose Radii	790 Concave, Convex, and Corner- Rounding Arbor-Type Cutters
746 Tool Angle Tolerances	792 Roller Chain Sprocket
746 Style G, Carbide Tipped Tools	794 Keys and Keyways
<b>CEMENTED CARBIDES</b>	795 Woodruff Keyseat Cutters
747 Cemented Carbide	799 Spline-Shaft Milling Cutter
747 Carbides and Carbonitrides	799 Cutter Grinding
748 Properties of Tungsten-Carbide- Based Cutting-Tool	800 Wheel Speeds and Feeds
752 ISO Classifications of Hardmetals	800 Clearance Angles
752 Ceramics	801 Rake Angles for Milling Cutters
755 Superhard Materials	801 Eccentric Type Radial Relief
756 Machining Data	804 Indicator Drop Method
757 Hardmetal Tooling	806 Distance to Set Tooth
757 Cutting Blades	

**TABLE OF CONTENTS**

<p style="text-align: center;"><b>REAMERS</b></p> <p>807 Hand Reamers</p> <p>808 Irregular Tooth Spacing in Reamers</p> <p>808 Threaded-end Hand Reamers</p> <p>808 Fluted and Rose Chucking Reamers</p> <p>811 Vertical Adjustment of Tooth-rest</p> <p>812 Reamer Difficulties</p> <p>813 Dimensions of Centers</p> <p>814 Expansion Chucking Reamers</p> <p>816 Hand Reamers</p> <p>817 Expansion Hand Reamers</p> <p>818 Driving Slots and Lugs</p> <p>819 Chucking Reamers</p> <p>822 Shell Reamers</p> <p>825 Taper Pipe Reamers</p>	<p style="text-align: center;"><b>TWIST DRILLS AND COUNTERBORES (Cont.)</b></p> <p>865 Spade Drills and Drilling</p> <p>865 Spade Drill Geometry</p> <p>867 Spade Drilling</p> <p>869 Feed Rates</p> <p>870 Power Consumption</p> <p>871 Trepanning</p>
<p style="text-align: center;"><b>TWIST DRILLS AND COUNTERBORES</b></p> <p>827 Definitions of Twist Drill Terms</p> <p>828 Types of Drill</p> <p>848 British Standard Combined Drills</p> <p>848 Split-Sleeve, Collet Type Drill Drivers</p> <p>849 Three- and Four-Flute Straight Shank Core Drills</p> <p>850 Drill Drivers</p> <p>850 British Standard Metric Twist Drills</p> <p>851 Gauge and Letter Sizes</p> <p>852 Morse Taper Shank Twist Drills</p> <p>853 Tolerance on Diameter</p> <p>854 Parallel Shank Jobber Series Twist Drills</p> <p>856 Stub Drills</p> <p>856 Steels for Twist Drills</p> <p>856 Accuracy of Drilled Holes</p> <p>857 Counterboring</p> <p>858 Interchangeable Cutters</p> <p>858 Three Piece Counterbores</p> <p>859 Style Designations</p> <p>859 Square Boring Tools</p> <p>859 Sintered Carbide Boring Tools</p> <p>860 Carbide-Tipped Square Boring Tools</p> <p>862 Solid Carbide Round Boring Tools</p>	<p style="text-align: center;"><b>TAPS AND THREADING DIES</b></p> <p>872 Types of Taps</p> <p>872 Definitions of Tap Terms</p> <p>876 Fraction-Size Taps</p> <p>878 Machine Screw Taps</p> <p>879 Ground Thread Limits</p> <p>880 Taper Pipe Taps</p> <p>881 Straight Pipe Taps</p> <p>883 Straight Fluted Taps</p> <p>885 Spiral-Pointed Taps</p> <p>890 ANSI Standard Taps</p> <p>891 Pulley Taps</p> <p>891 Spark Plug Taps</p> <p>893 Spiral Pointed Ground Thread Taps</p> <p>894 Taper and Straight Pipe Taps</p> <p>896 Thread Series Designations</p> <p>897 Pitch Diameter Tolerance</p> <p>897 Eccentricity Tolerances</p> <p>899 Acme Threads Taps</p> <p>900 Acme and Square-Threaded Taps</p> <p>901 Proportions</p> <p>901 Drill Hole Sizes</p> <p>902 Screwing Taps for ISO Metric Threads</p> <p>905 Tapping Square Threads</p>
<p style="text-align: center;"><b>TWIST DRILLS AND COUNTERBORES</b></p> <p>856 Stub Drills</p> <p>856 Steels for Twist Drills</p> <p>856 Accuracy of Drilled Holes</p> <p>857 Counterboring</p> <p>858 Interchangeable Cutters</p> <p>858 Three Piece Counterbores</p> <p>859 Style Designations</p> <p>859 Square Boring Tools</p> <p>859 Sintered Carbide Boring Tools</p> <p>860 Carbide-Tipped Square Boring Tools</p> <p>862 Solid Carbide Round Boring Tools</p>	<p style="text-align: center;"><b>STANDARD TAPERS</b></p> <p>906 Standard Tapers</p> <p>906 Morse Taper</p> <p>906 Brown &amp; Sharpe Taper</p> <p>906 Jarno Taper</p> <p>914 British Standard Tapers</p> <p>915 Morse Taper Sleeves</p> <p>916 Brown &amp; Sharpe Taper Shank</p> <p>917 Jarno Taper Shanks</p> <p>917 Machine Tool Spindles</p> <p>918 Plug and Ring Gages</p> <p>919 Jacobs Tapers and Threads</p> <p>920 Spindle Noses</p>

**TABLE OF CONTENTS**

<b>STANDARD TAPERS (Cont.)</b>	<b>JIGS AND FIXTURES</b>
922 Tool Shanks	941 Jig Bushings
923 Draw-in Bolt Ends	941 Materials
924 Spindle Nose	941 American National Standard
925 Twist Drills and Centering Tools	942 Head Type Press Fit Wearing Bushings
<b>BROACHES AND BROACHING</b>	
926 The Broaching Process	945 Specifications for Press Fit Wearing Bushings
926 Types of Broaches	945 Slip Type Renewable Wearing Bushings
927 Pitch of Broach Teeth	947 Fixed Type Renewable Wearing Bushings
928 Designing Data for Surface Broaches	948 Headless Type Liner Bushings
928 Broaching Pressure	950 Locking Mechanisms
929 Depth of Cut per Tooth	951 Jig Bushing Definitions
930 Face Angle or Rake	951 Jig Plate Thickness
930 Clearance Angle	951 Jig Bushing Designation System
930 Land Width	951 Definition of Jig and Fixture
930 Depth of Broach Teeth	951 Jig Borers
930 Radius of Tooth Fillet	952 Jig-Boring Practice
930 Total Length of Broach	953 Transfer of Tolerances
930 Chip Breakers	955 Lengths of Chords
931 Shear Angle	956 Hole Coordinate Dimension Factors
931 Types of Broaching Machines	957 Spacing Off the Circumferences of Circles
931 Broaching Difficulties	959 Hole Coordinate Dimension Factors
933 Tool Wear	971 Collets
935 Sharpening Twist Drills	971 Collets for Lathes, Mills, Grinders, and Fixtures
935 Relief Grinding of the Tool Flanks	
936 Drill Point Thinning	
937 Sharpening Carbide Tools	
937 Silicon Carbide Wheels	
938 Diamond Wheels	
938 Diamond Wheel Grit Sizes	
938 Diamond Wheel Grades	
938 Diamond Concentration	
939 Dry Versus Wet Grinding of Carbide Tools	
939 Coolants for Carbide Tool Grinding	
939 Peripheral Versus Flat Side Grinding	
940 Lapping Carbide Tools	
940 Chip Breaker Grinding	
940 Summary of Miscellaneous Points	

## CUTTING TOOLS

**Tool Contour.**—Tools for turning, planing, etc., are made in straight, bent, offset, and other forms to place the cutting edges in convenient positions for operating on differently located surfaces. The contour or shape of the cutting edge may also be varied to suit different classes of work. Tool shapes, however, are not only related to the kind of operation, but, in roughing tools particularly, the contour may have a decided effect upon the cutting efficiency of the tool. To illustrate, an increase in the side cutting-edge angle of a roughing tool, or in the nose radius, tends to permit higher cutting speeds because the chip will be thinner for a given feed rate. Such changes, however, may result in chattering or vibrations unless the work and the machine are rigid; hence, the most desirable contour may be a compromise between the ideal form and one that is needed to meet practical requirements.

**Terms and Definitions.**—The terms and definitions relating to single-point tools vary somewhat in different plants, but the following are in general use.

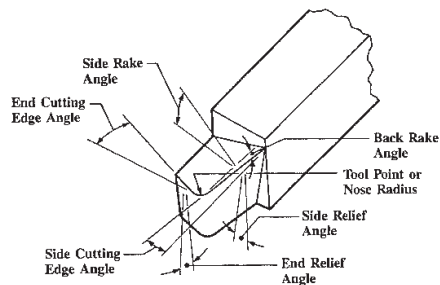

Fig. 1. Terms Applied to Single-point Turning Tools

**Single-point Tool:** This term is applied to tools for turning, planing, boring, etc., which have a cutting edge at one end. This cutting edge may be formed on one end of a solid piece of steel, or the cutting part of the tool may consist of an insert or tip which is held to the body of the tool by brazing, welding, or mechanical means.

**Shank:** The shank is the main body of the tool. If the tool is an inserted cutter type, the shank supports the cutter or bit. (See diagram, Fig. 1.)

**Nose:** A general term sometimes used to designate the cutting end but usually relating more particularly to the rounded tip of the cutting end.

**Face:** The surface against which the chips bear, as they are severed in turning or planing operations, is called the face.

**Flank:** The flank is that end surface adjacent to the cutting edge and below it when the tool is in a horizontal position as for turning.

**Base:** The base is the surface of the tool shank that bears against the supporting tool-holder or block.

**Side Cutting Edge:** The side cutting edge is the cutting edge on the side of the tool. Tools such as shown in Fig. 1 do the bulk of the cutting with this cutting edge and are, therefore, sometimes called side cutting edge tools.

**End Cutting Edge:** The end cutting edge is the cutting edge at the end of the tool.

On side cutting edge tools, the end cutting edge can be used for light plunging and facing cuts. Cutoff tools and similar tools have only one cutting edge located on the end. These

tools and other tools that are intended to cut primarily with the end cutting edge are sometimes called end cutting edge tools.

**Rake:** A metal-cutting tool is said to have rake when the tool face or surface against which the chips bear as they are being severed, is inclined for the purpose of either increasing or diminishing the keenness or bluntness of the edge. The magnitude of the rake is most conveniently measured by two angles called the back rake angle and the side rake angle. The tool shown in Fig. 1 has rake. If the face of the tool did not incline but was parallel to the base, there would be no rake; the rake angles would be zero.

**Positive Rake:** If the inclination of the tool face is such as to make the cutting edge keener or more acute than when the rake angle is zero, the rake angle is defined as positive.

**Negative Rake:** If the inclination of the tool face makes the cutting edge less keen or more blunt than when the rake angle is zero, the rake is defined as negative.

**Back Rake:** The back rake is the inclination of the face toward or away from the end or the end cutting edge of the tool. When the inclination is away from the end cutting edge, as shown in Fig. 1, the back rake is positive. If the inclination is downward toward the end cutting edge the back rake is negative.

**Side Rake:** The side rake is the inclination of the face toward or away from the side cutting edge. When the inclination is away from the side cutting edge, as shown in Fig. 1, the side rake is positive. If the inclination is toward the side cutting edge the side rake is negative.

**Relief:** The flanks below the side cutting edge and the end cutting edge must be relieved to allow these cutting edges to penetrate into the workpiece when taking a cut. If the flanks are not provided with relief, the cutting edges will rub against the workpiece and be unable to penetrate in order to form the chip. Relief is also provided below the nose of the tool to allow it to penetrate into the workpiece. The relief at the nose is usually a blend of the side relief and the end relief.

**End Relief Angle:** The end relief angle is a measure of the relief below the end cutting edge.

**Side Relief Angle:** The side relief angle is a measure of the relief below the side cutting edge.

**Back Rake Angle:** The back rake angle is a measure of the back rake. It is measured in a plane that passes through the side cutting edge and is perpendicular to the base. Thus, the back rake angle can be defined by measuring the inclination of the side cutting edge with respect to a line or plane that is parallel to the base. The back rake angle may be positive, negative, or zero depending upon the magnitude and direction of the back rake.

**Side Rake Angle:** The side rake angle is a measure of the side rake. This angle is always measured in a plane that is perpendicular to the side cutting edge and perpendicular to the base. Thus, the side rake angle is the angle of inclination of the face perpendicular to the side cutting edge with reference to a line or a plane that is parallel to the base.

**End Cutting Edge Angle:** The end cutting edge angle is the angle made by the end cutting edge with respect to a plane perpendicular to the axis of the tool shank. It is provided to allow the end cutting edge to clear the finish machined surface on the workpiece.

**Side Cutting Edge Angle:** The side cutting edge angle is the angle made by the side cutting edge and a plane that is parallel to the side of the shank.

**Nose Radius:** The nose radius is the radius of the nose of the tool. The performance of the tool, in part, is influenced by nose radius so that it must be carefully controlled.

**Lead Angle:** The lead angle, shown in Fig. 2, is not ground on the tool. It is a tool setting angle which has a great influence on the performance of the tool. The lead angle is bounded by the side cutting edge and a plane perpendicular to the workpiece surface when the tool is in position to cut; or, more exactly, the lead angle is the angle between the side cutting edge and a plane perpendicular to the direction of the feed travel.

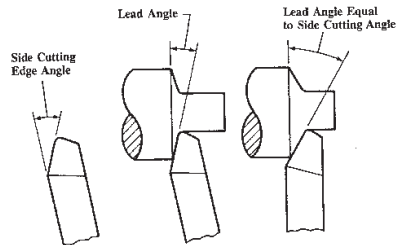

Fig. 2. Lead Angle on Single-point Turning Tool

**Solid Tool:** A solid tool is a cutting tool made from one piece of tool material.

**Brazed Tool:** A brazed tool is a cutting tool having a blank of cutting-tool material permanently brazed to a steel shank.

**Blank:** A blank is an unground piece of cutting-tool material from which a brazed tool is made.

**Tool Bit:** A tool bit is a relatively small cutting tool that is clamped in a holder in such a way that it can readily be removed and replaced. It is intended primarily to be reground when dull and not indexed.

**Tool-bit Blank:** The tool-bit blank is an unground piece of cutting-tool material from which a tool bit can be made by grinding. It is available in standard sizes and shapes.

**Tool-bit Holder:** Usually made from forged steel, the tool-bit holder is used to hold the tool bit, to act as an extended shank for the tool bit, and to provide a means for clamping in the tool post.

**Straight-shank Tool-bit Holder:** A straight-shank tool-bit holder has a straight shank when viewed from the top. The axis of the tool bit is held parallel to the axis of the shank.

**Offset-shank Tool-bit Holder:** An offset-shank tool-bit holder has the shank bent to the right or left, as seen in Fig. 3. The axis of the tool bit is held at an angle with respect to the axis of the shank.

**Side cutting Tool:** A side cutting tool has its major cutting edge on the side of the cutting part of the tool. The major cutting edge may be parallel or at an angle with respect to the axis of the tool.

**Indexable Inserts:** An indexable insert is a relatively small piece of cutting-tool material that is geometrically shaped to have two or several cutting edges that are used until dull. The insert is then indexed on the holder to apply a sharp cutting edge. When all the cutting edges have been dulled, the insert is discarded. The insert is held in a pocket or against other locating surfaces on an indexable insert holder by means of a mechanical clamping device that can be tightened or loosened easily.

**Indexable Insert Holder:** Made of steel, an indexable insert holder is used to hold indexable inserts. It is equipped with a mechanical clamping device that holds the inserts firmly in a pocket or against other seating surfaces.

**Straight-shank Indexable Insert Holder:** A straight-shank indexable insert tool-holder is essentially straight when viewed from the top, although the cutting edge of the insert may be oriented parallel, or at an angle to, the axis of the holder.

**Offset-shank Indexable Insert Holder:** An offset-shank indexable insert holder has the head end, or the end containing the insert pocket, offset to the right or left, as shown in Fig. 3.



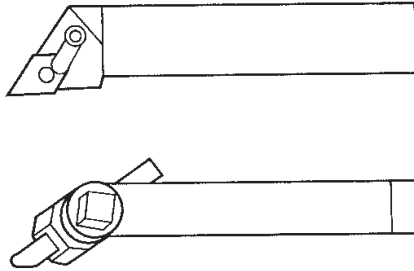

Fig. 3. Top: Right-hand Offset-shank, Indexable Insert Holder  
Bottom: Right-hand Offset-shank Tool-bit Holder

**End cutting Tool:** An end cutting tool has its major cutting edge on the end of the cutting part of the tool. The major cutting edge may be perpendicular or at an angle, with respect to the axis of the tool.

**Curved Cutting-edge Tool:** A curved cutting-edge tool has a continuously variable side cutting edge angle. The cutting edge is usually in the form of a smooth, continuous curve along its entire length, or along a large portion of its length.

**Right-hand Tool:** A right-hand tool has the major, or working, cutting edge on the right-hand side when viewed from the cutting end with the face up. As used in a lathe, such a tool is usually fed into the work from right to left, when viewed from the shank end.

**Left-hand Tool:** A left-hand tool has the major or working cutting edge on the left-hand side when viewed from the cutting end with the face up. As used in a lathe, the tool is usually fed into the work from left to right, when viewed from the shank end.

**Neutral-hand Tool:** A neutral-hand tool is a tool to cut either left to right or right to left; or the cut may be parallel to the axis of the shank as when plunge cutting.

**Chipbreaker:** A groove formed in or on a shoulder on the face of a turning tool back of the cutting edge to break up the chips and prevent the formation of long, continuous chips which would be dangerous to the operator and also bulky and cumbersome to handle. A chipbreaker of the shoulder type may be formed directly on the tool face or it may consist of a separate piece that is held either by brazing or by clamping.

**Relief Angles.**—The end relief angle and the side relief angle on single-point cutting tools are usually, though not invariably, made equal to each other. The relief angle under the nose of the tool is a blend of the side and end relief angles.

The size of the relief angles has a pronounced effect on the performance of the cutting tool. If the relief angles are too large, the cutting edge will be weakened and in danger of breaking when a heavy cutting load is placed on it by a hard and tough material. On finish cuts, rapid wear of the cutting edge may cause problems with size control on the part. Relief angles that are too small will cause the rate of wear on the flank of the tool below the cutting edge to increase, thereby significantly reducing the tool life. In general, when cutting hard and tough materials, the relief angles should be 6 to 8 degrees for high-speed steel tools and 5 to 7 degrees for carbide tools. For medium steels, mild steels, cast iron, and other average work the recommended values of the relief angles are 8 to 12 degrees for high-speed steel tools and 5 to 10 degrees for carbides. Ductile materials having a relatively low modulus of elasticity should be cut using larger relief angles. For example, the relief angles recommended for turning copper, brass, bronze, aluminum, ferritic malleable

iron, and similar metals are 12 to 16 degrees for high-speed steel tools and 8 to 14 degrees for carbides.

Larger relief angles generally tend to produce a better finish on the finish machined surface because less surface of the worn flank of the tool rubs against the workpiece. For this reason, single-point thread-cutting tools should be provided with relief angles that are as large as circumstances will permit. Problems encountered when machining stainless steel may be overcome by increasing the size of the relief angle. The relief angles used should never be smaller than necessary.

**Rake Angles.**—Machinability tests have confirmed that when the rake angle along which the chip slides, called the true rake angle, is made larger in the positive direction, the cutting force and the cutting temperature will decrease. Also, the tool life for a given cutting speed will increase with increases in the true rake angle up to an optimum value, after which it will decrease again. For turning tools which cut primarily with the side cutting edge, the true rake angle corresponds rather closely with the side rake angle except when taking shallow cuts. Increasing the side rake angle in the positive direction lowers the cutting force and the cutting temperature, while at the same time it results in a longer tool life or a higher permissible cutting speed up to an optimum value of the side rake angle. After the optimum value is exceeded, the cutting force and the cutting temperature will continue to drop; however, the tool life and the permissible cutting speed will decrease.

As an approximation, the magnitude of the cutting force will decrease about one per cent per degree increase in the side rake angle. While not exact, this rule of thumb does correspond approximately to test results and can be used to make rough estimates. Of course, the cutting force also increases about one per cent per degree decrease in the side rake angle. The limiting value of the side rake angle for optimum tool life or cutting speed depends upon the work material and the cutting tool material. In general, lower values can be used for hard and tough work materials. Cemented carbides are harder and more brittle than high-speed steel; therefore, the rake angles usually used for cemented carbides are less positive than for high-speed steel.

Negative rake angles cause the face of the tool to slope in the opposite direction from positive rake angles and, as might be expected, they have an opposite effect. For side cutting edge tools, increasing the side rake angle in a negative direction will result in an increase in the cutting force and an increase in the cutting temperature of approximately one per cent per degree change in rake angle. For example, if the side rake angle is changed from 5 degrees positive to 5 degrees negative, the cutting force will be about 10 per cent larger. Usually the tool life will also decrease when negative side rake angles are used, although the tool life will sometimes increase when the negative rake angle is not too large and when a fast cutting speed is used.

Negative side rake angles are usually used in combination with negative back rake angles on single-point cutting tools. The negative rake angles strengthen the cutting edges enabling them to sustain heavier cutting loads and shock loads. They are recommended for turning very hard materials and for heavy interrupted cuts. There is also an economic advantage in favor of using negative rake indexable inserts and tool holders inasmuch as the cutting edges provided on both the top and bottom of the insert can be used.

On turning tools that cut primarily with the side cutting edge, the effect of the back rake angle alone is much less than the effect of the side rake angle although the direction of the change in cutting force, cutting temperature, and tool life is the same. The effect that the back rake angle has can be ignored unless, of course, extremely large changes in this angle are made. A positive back rake angle does improve the performance of the nose of the tool somewhat and is helpful in taking light finishing cuts. A negative back rake angle strengthens the nose of the tool and is helpful when interrupted cuts are taken. The back rake angle has a very significant effect on the performance of end cutting edge tools, such as cut-off tools. For these tools, the effect of the back rake angle is very similar to the effect of the side rake angle on side cutting edge tools.

**Side Cutting Edge and Lead Angles.**—These angles are considered together because the side cutting edge angle is usually designed to provide the desired lead angle when the tool is being used. The side cutting edge angle and the lead angle will be equal when the shank of the cutting tool is positioned perpendicular to the workpiece, or, more correctly, perpendicular to the direction of the feed. When the shank is not perpendicular, the lead angle is determined by the side cutting edge and an imaginary line perpendicular to the feed direction.

The flow of the chips over the face of the tool is approximately perpendicular to the side cutting edge except when shallow cuts are taken. The thickness of the undeformed chip is measured perpendicular to the side cutting edge. As the lead angle is increased, the length of chip in contact with the side cutting edge is increased, and the chip will become longer and thinner. This effect is the same as increasing the depth of cut and decreasing the feed, although the actual depth of cut and feed remain the same and the same amount of metal is removed. The effect of lengthening and thinning the chip by increasing the lead angle is very beneficial as it increases the tool life for a given cutting speed or that speed can be increased. Increasing the cutting speed while the feed and the tool life remain the same leads to faster production.

However, an adverse effect must be considered. Chatter can be caused by a cutting edge that is oriented at a high lead angle when turning and sometimes, when turning long and slender shafts, even a small lead angle can cause chatter. In fact, an unsuitable lead angle of the side cutting edge is one of the principal causes of chatter. When chatter occurs, often simply reducing the lead angle will cure it. Sometimes, very long and slender shafts can be turned successfully with a tool having a zero degree lead angle (and having a small nose radius). Boring bars, being usually somewhat long and slender, are also susceptible to chatter if a large lead angle is used. The lead angle for boring bars should be kept small, and for very long and slender boring bars a zero degree lead angle is recommended. It is impossible to provide a rule that will determine when chatter caused by a lead angle will occur and when it will not. In making a judgment, the first consideration is the length to diameter ratio of the part to be turned, or of the boring bar. Then the method of holding the workpiece must be considered—a part that is firmly held is less apt to chatter. Finally, the overall condition and rigidity of the machine must be considered because they may be the real cause of chatter.

Although chatter can be a problem, the advantages gained from high lead angles are such that the lead angle should be as large as possible at all times.

**End Cutting Edge Angle.**—The size of the end cutting edge angle is important when tool wear by cratering occurs. Frequently, the crater will enlarge until it breaks through the end cutting edge just behind the nose, and tool failure follows shortly. Reducing the size of the end cutting edge angle tends to delay the time of crater breakthrough. When cratering takes place, the recommended end cutting edge angle is 8 to 15 degrees. If there is no cratering, the angle can be made larger. Larger end cutting edge angles may be required to enable profile turning tools to plunge into the work without interference from the end cutting edge.

**Nose Radius.**—The tool nose is a very critical part of the cutting edge since it cuts the finished surface on the workpiece. If the nose is made to a sharp point, the finish machined surface will usually be unacceptable and the life of the tool will be short. Thus, a nose radius is required to obtain an acceptable surface finish and tool life. The surface finish obtained is determined by the feed rate and by the nose radius if other factors such as the work material, the cutting speed, and cutting fluids are not considered. A large nose radius will give a better surface finish and will permit a faster feed rate to be used.

Machinability tests have demonstrated that increasing the nose radius will also improve the tool life or allow a faster cutting speed to be used. For example, high-speed steel tools were used to turn an alloy steel in one series of tests where complete or catastrophic tool failure was used as a criterion for the end of tool life. The cutting speed for a 60-minute tool

life was found to be 125 fpm when the nose radius was  $\frac{1}{16}$  inch and 160 fpm when the nose radius was  $\frac{1}{4}$  inch.

A very large nose radius can often be used but a limit is sometimes imposed because the tendency for chatter to occur is increased as the nose radius is made larger. A nose radius that is too large can cause chatter and when it does, a smaller nose radius must be used on the tool. It is always good practice to make the nose radius as large as is compatible with the operation being performed.

**Chipbreakers.**—Many steel turning tools are equipped with chipbreaking devices to prevent the formation of long continuous chips in connection with the turning of steel at the high speeds made possible by high-speed steel and especially cemented carbide tools. Long steel chips are dangerous to the operator, and cumbersome to handle, and they may twist around the tool and cause damage. Broken chips not only occupy less space, but permit a better flow of coolant to the cutting edge. Several different forms of chipbreakers are illustrated in Fig. 4.

*Angular Shoulder Type:* The angular shoulder type shown at A is one of the commonly used forms. As the enlarged sectional view shows, the chipbreaking shoulder is located back of the cutting edge. The angle  $a$  between the shoulder and cutting edge may vary from 6 to 15 degrees or more, 8 degrees being a fair average. The ideal angle, width  $W$  and depth  $G$ , depend upon the speed and feed, the depth of cut, and the material. As a general rule, width  $W$ , at the end of the tool, varies from  $\frac{3}{32}$  to  $\frac{1}{2}$  inch, and the depth  $G$  may range from  $\frac{1}{64}$  to  $\frac{1}{16}$  inch. The shoulder radius equals depth  $G$ . If the tool has a large nose radius, the corner of the shoulder at the nose end may be beveled off, as illustrated at B, to prevent it from coming into contact with the work. The width  $K$  for type B should equal approximately 1.5 times the nose radius.

*Parallel Shoulder Type:* Diagram C shows a design with a chipbreaking shoulder that is parallel with the cutting edge. With this form, the chips are likely to come off in short curled sections. The parallel form may also be applied to straight tools which do not have a side cutting-edge angle. The tendency with this parallel shoulder form is to force the chips against the work and damage it.

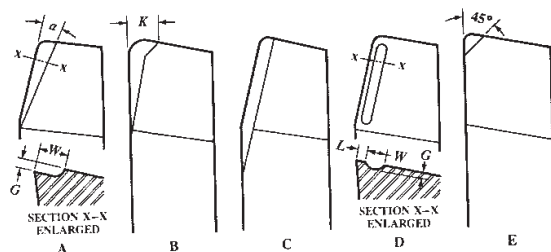

Fig. 4. Different Forms of Chipbreakers for Turning Tools

*Groove Type:* This type (diagram D) has a groove in the face of the tool produced by grinding. Between the groove and the cutting edge, there is a land  $L$ . Under ideal conditions, this width  $L$ , the groove width  $W$ , and the groove depth  $G$ , would be varied to suit the feed, depth of cut and material. For average use,  $L$  is about  $\frac{1}{32}$  inch;  $G$ ,  $\frac{1}{32}$  inch; and  $W$ ,  $\frac{1}{16}$  inch. There are differences of opinion concerning the relative merits of the groove type and

the shoulder type. Both types have proved satisfactory when properly proportioned for a given class of work.

*Chipbreaker for Light Cuts:* Diagram E illustrates a form of chipbreaker that is sometimes used on tools for finishing cuts having a maximum depth of about  $\frac{1}{32}$  inch. This chipbreaker is a shoulder type having an angle of 45 degrees and a maximum width of about  $\frac{1}{16}$  inch. It is important in grinding all chipbreakers to give the chip-bearing surfaces a fine finish, such as would be obtained by honing. This finish greatly increases the life of the tool.

**Planing Tools.**—Many of the principles which govern the shape of turning tools also apply in the grinding of tools for planing. The amount of rake depends upon the hardness of the material, and the direction of the rake should be away from the *working part* of the cutting edge. The angle of clearance should be about 4 or 5 degrees for planer tools, which is less than for lathe tools. This small clearance is allowable because a planer tool is held about square with the platen, whereas a lathe tool, the height and inclination of which can be varied, may not always be clamped in the same position.

*Carbide Tools:* Carbide tools for planing usually have negative rake. Round-nose and square-nose end-cutting tools should have a "negative back rake" (or front rake) of 2 or 3 degrees. Side cutting tools may have a negative back rake of 10 degrees, a negative side rake of 5 degrees, and a side cutting-edge angle of 8 degrees.

**Indexable Inserts.**—A large proportion of the cemented carbide, single-point cutting tools are indexable inserts and indexable insert tool holders. Dimensional specifications for solid sintered carbide indexable inserts are given in American National Standard ANSI B212.12-1991. Samples of the many insert shapes are shown in Table 3. Most modern, cemented carbide, face milling cutters are of the indexable insert type. Larger size end milling cutters, side milling or slotting cutters, boring tools, and a wide variety of special tools are made to use indexable inserts. These inserts are primarily made from cemented carbide, although most of the cemented oxide cutting tools are also indexable inserts.

The objective of this type of tooling is to provide an insert with several cutting edges. When an edge is worn, the insert is indexed in the tool holder until all the cutting edges are used up, after which it is discarded. The insert is not intended to be reground. The advantages are that the cutting edges on the tool can be rapidly changed without removing the tool holder from the machine, tool-grinding costs are eliminated, and the cost of the insert is less than the cost of a similar, brazed carbide tool. Of course, the cost of the tool holder must be added to the cost of the insert; however, one tool holder will usually last for a long time before it, too, must be replaced.

Indexable inserts and tool holders are made with a negative rake or with a positive rake. Negative rake inserts have the advantage of having twice as many cutting edges available as comparable positive rake inserts, because the cutting edges on both the top and bottom of negative rake inserts can be used, while only the top cutting edges can be used on positive rake inserts. Positive rake inserts have a distinct advantage when machining long and slender parts, thin-walled parts, or other parts that are subject to bending or chatter when the cutting load is applied to them, because the cutting force is significantly lower as compared to that for negative rake inserts. Indexable inserts can be obtained in the following forms: utility ground, or ground on top and bottom only; precision ground, or ground on all surfaces; preformed to produce a slight rounding of the cutting edge; and precision molded, which are unground. Positive-negative rake inserts also are available. These inserts are held on a negative-rake tool holder and have a chipbreaker groove that is formed to produce an effective positive-rake angle while cutting. Cutting edges may be available on the top surface only, or on both top and bottom surfaces. The positive-rake chipbreaker surface may be ground or precision molded on the insert.

Many materials, such as gray cast iron, form a discontinuous chip. For these materials an insert that has plain faces without chipbreaker grooves should always be used. Steels and other ductile materials form a continuous chip that must be broken into small segments

when machined on lathes and planers having single-point, cemented-carbide and cemented-oxide cutting tools; otherwise, the chips can cause injury to the operator. In this case a chipbreaker must be used. Some inserts are made with chipbreaker grooves molded or ground directly on the insert. When inserts with plain faces are used, a cemented-carbide plate-type chipbreaker is clamped on top of the insert.

**Identification System for Indexable Inserts.**—The size of indexable inserts is determined by the diameter of an inscribed circle (I.C.), except for rectangular and parallelogram inserts where the length and width dimensions are used. To describe an insert in its entirety, a standard ANSI B212.4-1986 identification system is used where each position number designates a feature of the insert. The ANSI Standard includes items now commonly used and facilitates identification of items not in common use. Identification consists of up to ten positions; each position defines a characteristic of the insert as shown below:

1	2	3	4	5	6	7	8 <sup>a</sup>	9 <sup>a</sup>	10 <sup>a</sup>
T	N	M	G	5	4	3			A

<sup>a</sup>Eighth, Ninth, and Tenth Positions are used only when required.

1) *Shape:* The shape of an insert is designated by a letter: R for round; S, square; T, triangle; A, 85° parallelogram; B, 82° parallelogram; C, 80° diamond; D, 55° diamond; E, 75° diamond; H, hexagon; K, 55° parallelogram; L, rectangle; M, 86° diamond; O, octagon; P, pentagon; V, 35° diamond; and W, 80° trigon.

2) *Relief Angle (Clearances):* The second position is a letter denoting the relief angles; N for 0°; A, 3°; B, 5°; C, 7°; P, 11°; D, 15°; E, 20°; F, 25°; G, 30°; H, 0° & 11°; J, 0° & 14°; K, 0° & 17°; L, 0° & 20°; M, 11° & 14°; R, 11° & 17°; S, 11° & 20°. When mounted on a holder, the actual relief angle may be different from that on the insert.

3) *Tolerances:* The third position is a letter and indicates the tolerances which control the indexability of the insert. Tolerances specified do not imply the method of manufacture.

Symbol	Tolerance (± from nominal)		Symbol	Tolerance (± from nominal)	
	Inscribed Circle, Inch	Thickness, Inch		Inscribed Circle, Inch	Thickness, Inch
A	0.001	0.001	H	0.0005	0.001
B	0.001	0.005	J	0.002-0.005	0.001
C	0.001	0.001	K	0.002-0.005	0.001
D	0.001	0.005	L	0.002-0.005	0.001
E	0.001	0.001	M	0.002-0.004 <sup>a</sup>	0.005
F	0.0005	0.001	U	0.005-0.010 <sup>a</sup>	0.005
G	0.001	0.005	N	0.002-0.004 <sup>a</sup>	0.001

<sup>a</sup>Exact tolerance is determined by size of insert. See ANSI B94.25.

4) *Type:* The type of insert is designated by a letter. A, with hole; B, with hole and countersink; C, with hole and two countersinks; F, chip grooves both surfaces, no hole; G, same as F but with hole; H, with hole, one countersink, and chip groove on one rake surface; J, with hole, two countersinks and chip grooves on two rake surfaces; M, with hole and chip groove on one rake surface; N, without hole; Q, with hole and two countersinks; R, without hole but with chip groove on one rake surface; T, with hole, one countersink, and chip groove on one rake face; U, with hole, two countersinks, and chip grooves on two rake faces; and W, with hole and one countersink. *Note:* a dash may be used after position 4 to

<sup>a</sup>Second angle is secondary facet angle, which may vary by ±1°.

separate the shape-describing portion from the following dimensional description of the insert and is not to be considered a position in the standard description.

5) *Size*: The size of the insert is designated by a one- or a two-digit number. For regular polygons and diamonds, it is the number of eighths of an inch in the nominal size of the inscribed circle, and will be a one- or two-digit number when the number of eighths is a whole number. It will be a two-digit number, including one decimal place, when it is not a whole number. Rectangular and parallelogram inserts require two digits: the first digit indicates the number of eighths of an inch width and the second digit, the number of quarters of an inch length.

6) *Thickness*: The thickness is designated by a one- or two-digit number, which indicates the number of sixteenths of an inch in the thickness of the insert. It is a one-digit number when the number of sixteenths is a whole number; it is a two-digit number carried to one decimal place when the number of sixteenths of an inch is not a whole number.

7) *Cutting Point Configuration*: The cutting point, or nose radius, is designated by a number representing  $\frac{1}{64}$ ths of an inch; a flat at the cutting point or nose, is designated by a letter: **0** for sharp corner; **1**,  $\frac{1}{64}$  inch radius; **2**,  $\frac{1}{32}$  inch radius; **3**,  $\frac{3}{64}$  inch radius; **4**,  $\frac{1}{16}$  inch radius; **5**,  $\frac{5}{64}$  inch radius; **6**,  $\frac{3}{32}$  inch radius; **7**,  $\frac{7}{64}$  inch radius; **8**,  $\frac{1}{8}$  inch radius; **A**, square insert with 45° chamfer; **D**, square insert with 30° chamfer; **E**, square insert with 15° chamfer; **F**, square insert with 3° chamfer; **K**, square insert with 30° double chamfer; **L**, square insert with 15° double chamfer; **M**, square insert with 3° double chamfer; **N**, truncated triangle insert; and **P**, flattened corner triangle insert.

8) *Special Cutting Point Definition*: The eighth position, if it follows a letter in the 7th position, is a number indicating the number of  $\frac{1}{64}$ ths of an inch measured parallel to the edge of the facet.

9) *Hand*: **R**, right; **L**, left; to be used when required in ninth position.

10) *Other Conditions*: The tenth position defines special conditions (such as edge treatment, surface finish) as follows: **A**, honed, 0.0005 inch to less than 0.003 inch; **B**, honed, 0.003 inch to less than 0.005 inch; **C**, honed, 0.005 inch to less than 0.007 inch; **J**, polished, 4 microinch arithmetic average (AA) on rake surfaces only; **T**, chamfered, manufacturer's standard negative land, rake face only.

**Indexable Insert Tool Holders.**—Indexable insert tool holders are made from a good grade of steel which is heat treated to a hardness of 44 to 48 Rc for most normal applications. Accurate pockets that serve to locate the insert in position and to provide surfaces against which the insert can be clamped are machined in the ends of tool holders. A cemented carbide seat usually is provided, and is held in the bottom of the pocket by a screw or by the clamping pin, if one is used. The seat is necessary to provide a flat bearing surface upon which the insert can rest and, in so doing, it adds materially to the ability of the insert to withstand the cutting load. The seating surface of the holder may provide a positive-, negative-, or a neutral-rake orientation to the insert when it is in position on the holder. Holders, therefore, are classified as positive, negative, or neutral rake.

Four basic methods are used to clamp the insert on the holder: 1) Clamping, usually top clamping; 2) Pin-lock clamping; 3) Multiple clamping using a clamp, usually a top clamp, and a pin lock; and 4) Clamping the insert with a machine screw.

All top clamps are actuated by a screw that forces the clamp directly against the insert. When required, a cemented-carbide, plate-type chipbreaker is placed between the clamp and the insert. Pin-lock clamps require an insert having a hole: the pin acts against the walls of the hole to clamp the insert firmly against the seating surfaces of the holder. Multiple or combination clamping, simultaneously using both a pin-lock and a top clamp, is recommended when taking heavier or interrupted cuts. Holders are available on which all the above-mentioned methods of clamping may be used. Other holders are made with only a top clamp or a pin lock. Screw-on type holders use a machine screw to hold the insert in the

pocket. Most standard indexable insert holders are either straight-shank or offset-shank, although special holders are made having a wide variety of configurations.

The common shank sizes of indexable insert tool holders are shown in Table 1. Not all styles are available in every shank size. Positive- and negative-rake tools are also not available in every style or shank size. Some manufacturers provide additional shank sizes for certain tool holder styles. For more complete details the manufacturers' catalogs must be consulted.

Table 1. Standard Shank Sizes for Indexable Insert Holders

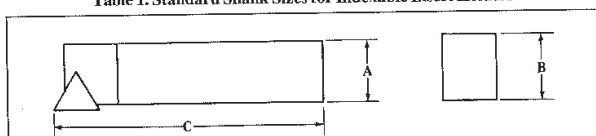

Basic Shank Size	Shank Dimensions for Indexable Insert Holders					
	A		B		C*	
	In.	mm	In.	mm	In.	mm
1/2 x 1/2 x 4 1/2	0.500	12.70	0.500	12.70	4.500	114.30
3/8 x 3/8 x 4 1/2	0.625	15.87	0.625	15.87	4.500	114.30
3/8 x 1 1/4 x 6	0.625	15.87	1.250	31.75	6.000	152.40
1/2 x 3/4 x 4 1/2	0.750	19.05	0.750	19.05	4.500	114.30
1/2 x 1 x 6	0.750	19.05	1.000	25.40	6.000	152.40
3/4 x 1 1/4 x 6	0.750	19.05	1.250	31.75	6.000	152.40
1 x 1 x 6	1.000	25.40	1.000	25.40	6.000	152.40
1 x 1 1/4 x 6	1.000	25.40	1.250	31.75	6.000	152.40
1 x 1 1/2 x 6	1.000	25.40	1.500	38.10	6.000	152.40
1 1/4 x 1 1/4 x 7	1.250	31.75	1.250	31.75	7.000	177.80
1 1/4 x 1 1/2 x 8	1.250	31.75	1.500	38.10	8.000	203.20
1 3/8 x 2 1/8 x 6 1/2	1.375	34.92	2.062	52.37	6.380	162.05
1 3/8 x 1 3/4 x 7	1.500	38.10	1.500	38.10	7.000	177.80
1 3/4 x 1 3/4 x 9 1/2	1.750	44.45	1.750	44.45	9.500	241.30
2 x 2 x 8	2.000	50.80	2.000	50.80	8.000	203.20

\*Holder length; may vary by manufacturer. Actual shank length depends on holder style.

**Identification System for Indexable Insert Holders.**—The following identification system conforms to the American National Standard, ANSI B212.5-1986, Metric Holders for Indexable Inserts.

Each position in the system designates a feature of the holder in the following sequence:

1 2 3 4 5 — 6 — 7 — 8<sup>a</sup> — 9 — 10<sup>a</sup>

C T N A R — 85 — 25 — D — 16 — Q

1) *Method of Holding Horizontally Mounted Insert:* The method of holding or clamping is designated by a letter: C, top clamping, insert without hole; M, top and hole clamping, insert with hole; P, hole clamping, insert with hole; S, screw clamping through hole, insert with hole; W, wedge clamping.

2) *Insert Shape:* The insert shape is identified by a letter: H, hexagonal; O, octagonal; P, pentagonal; S, square; T, triangular; C, rhombic, 80° included angle; D, rhombic, 55° included angle; E, rhombic, 75° included angle; M, rhombic, 86° included angle; V, rhombic, 35° included angle; W, hexagonal, 80° included angle; L, rectangular; A, parallelogram, 85° included angle; B, parallelogram, 82° included angle; K, parallelogram, 55° included angle; R, round. The included angle is always the smaller angle.

3) *Holder Style:* The holder style designates the shank style and the side cutting edge angle, or end cutting edge angle, or the purpose for which the holder is used. It is design-



nated by a letter: **A**, for straight shank with 0° side cutting edge angle; **B**, straight shank with 15° side cutting edge angle; **C**, straight-shank end cutting tool with 0° end cutting edge angle; **D**, straight shank with 45° side cutting edge angle; **E**, straight shank with 30° side cutting edge angle; **F**, offset shank with 0° end cutting edge angle; **G**, offset shank with 0° side cutting edge angle; **J**, offset shank with negative 3° side cutting edge angle; **K**, offset shank with 15° end cutting edge angle; **L**, offset shank with negative 5° side cutting edge angle and 5° end cutting edge angle; **M**, straight shank with 40° side cutting edge angle; **N**, straight shank with 27° side cutting edge angle; **R**, offset shank with 15° side cutting edge angle; **S**, offset shank with 45° side cutting edge angle; **T**, offset shank with 30° side cutting edge angle; **U**, offset shank with negative 3° end cutting edge angle; **V**, straight shank with 17½° side cutting edge angle; **W**, offset shank with 30° end cutting edge angle; **Y**, offset shank with 5° end cutting edge angle.

4) *Normal Clearances*: The normal clearances of inserts are identified by letters: **A**, 3°; **B**, 5°; **C**, 7°; **D**, 15°; **E**, 20°; **F**, 25°; **G**, 30°; **N**, 0°; **P**, 11°.

5) *Hand of tool*: The hand of the tool is designated by a letter: **R** for right-hand; **L**, left-hand; and **N**, neutral, or either hand.

6) *Tool Height for Rectangular Shank Cross Sections*: The tool height for tool holders with a rectangular shank cross section and the height of cutting edge equal to shank height is given as a two-digit number representing this value in millimeters. For example, a height of 32 mm would be encoded as 32; 8 mm would be encoded as 08, where the one-digit value is preceded by a zero.

7) *Tool Width for Rectangular Shank Cross Sections*: The tool width for tool holders with a rectangular shank cross section is given as a two-digit number representing this value in millimeters. For example, a width of 25 mm would be encoded as 25; 8 mm would be encoded as 08, where the one-digit value is preceded by a zero.

8) *Tool Length*: The tool length is designated by a letter: **A**, 32 mm; **B**, 40 mm; **C**, 50 mm; **D**, 60 mm; **E**, 70 mm; **F**, 80 mm; **G**, 90 mm; **H**, 100 mm; **J**, 110 mm; **K**, 125 mm; **L**, 140 mm; **M**, 150 mm; **N**, 160 mm; **P**, 170 mm; **Q**, 180 mm; **R**, 200 mm; **S**, 250 mm; **T**, 300 mm; **U**, 350 mm; **V**, 400 mm; **W**, 450 mm; **X**, special length to be specified; **Y**, 500 mm.

9) *Indexable Insert Size*: The size of indexable inserts is encoded as follows: For insert shapes **C**, **D**, **E**, **H**, **M**, **O**, **P**, **R**, **S**, **T**, **V**, the side length (the diameter for **R** inserts) in millimeters is used as a two-digit number, with decimals being disregarded. For example, the symbol for a side length of 16.5 mm is 16. For insert shapes **A**, **B**, **K**, **L**, the length of the main cutting edge or of the longer cutting edge in millimeters is encoded as a two-digit number, disregarding decimals. If the symbol obtained has only one digit, then it should be preceded by a zero. For example, the symbol for a main cutting edge of 19.5 mm is 19; for an edge of 9.5 mm, the symbol is 09.

10) *Special Tolerances*: Special tolerances are indicated by a letter: **Q**, back and end qualified tool; **F**, front and end qualified tool; **B**, back, front, and end qualified tool. A qualified tool is one that has tolerances of  $\pm 0.08$  mm for dimensions *F*, *G*, and *C*. (See Table 2.)

Table 2. Letter Symbols for Qualification of Tool Holders — Position 10  
ANSI B212.5-1986

Qualification of Tool Holder	Letter Symbol		
	Q	F	B
	Back and end qualified tool	Front and end qualified tool	Back, front, and end qualified tool

**Selecting Indexable Insert Holders.**—A guide for selecting indexable insert holders is provided by Table 3b. Some operations such as deep grooving, cut-off, and threading are not given in this table. However, tool holders designed specifically for these operations are available. The boring operations listed in Table 3b refer primarily to larger holes, into which the holders will fit. Smaller holes are bored using boring bars. An examination of this table shows that several tool-holder styles can be used and frequently are used for each operation. Selection of the best holder for a given job depends largely on the job and there are certain basic facts that should be considered in making the selection.

**Rake Angle:** A negative-rake insert has twice as many cutting edges available as a comparable positive-rake insert. Sometimes the tool life obtained when using the second face may be less than that obtained on the first face because the tool wear on the cutting edges of the first face may reduce the insert strength. Nevertheless, the advantage of negative-rake inserts and holders is such that they should be considered first in making any choice. Positive-rake holders should be used where lower cutting forces are required, as when machining slender or small-diameter parts, when chatter may occur, and for machining some materials, such as aluminum, copper, and certain grades of stainless steel, when positive-negative rake inserts can sometimes be used to advantage. These inserts are held on negative-rake holders that have their rake surfaces ground or molded to form a positive-rake angle.

**Insert Shape:** The configuration of the workpiece, the operation to be performed, and the lead angle required often determine the insert shape. When these factors need not be considered, the insert shape should be selected on the basis of insert strength and the maximum number of cutting edges available. Thus, a round insert is the strongest and has a maximum number of available cutting edges. It can be used with heavier feeds while producing a good surface finish. Round inserts are limited by their tendency to cause chatter, which may preclude their use. The square insert is the next most effective shape, providing good corner strength and more cutting edges than all other inserts except the round insert. The only limitation of this insert shape is that it must be used with a lead angle. Therefore, the square insert cannot be used for turning square shoulders or for back-facing. Triangle inserts are the most versatile and can be used to perform more operations than any other insert shape. The 80-degree diamond insert is designed primarily for heavy turning and facing operations, using the 100-degree corners, and for turning and back-facing square shoulders using the 80-degree corners. The 55- and 35-degree diamond inserts are intended primarily for tracing.

**Lead Angle:** Tool holders should be selected to provide the largest possible lead angle, although limitations are sometimes imposed by the nature of the job. For example, when turning and back-facing a shoulder, a negative lead angle must be used. Slender or small-diameter parts may deflect, causing difficulties in holding size, or chatter when the lead angle is too large.

**End Cutting Edge Angle:** When tracing or contour turning, the plunge angle is determined by the end cutting edge angle. A 2-deg minimum clearance angle should be provided between the workpiece surface and the end cutting edge of the insert. Table 3a provides the maximum plunge angle for holders commonly used to plunge when tracing where insert shape identifiers are *S* = square; *T* = triangle; *D* = 55-deg diamond, *V* = 35-deg diamond. When severe cratering cannot be avoided, an insert having a small, end cutting edge angle is desirable to delay the crater breakthrough behind the nose. For very heavy cuts a small, end cutting edge angle will strengthen the corner of the tool. Tool holders for numerical control machines are discussed in the NC section, beginning page 1280.

Table 3a. Maximum Plunge Angle for Tracing or Contour Turning

Tool Holder Style	Insert Shape	Maximum Plunge Angle	Tool Holder Style	Insert Shape	Maximum Plunge Angle
E	T	58°	J	D	30°
D and S	S	43°	J	V	50°
H	D	71°	N	T	55°
J	T	25°	N	D	58°-60°

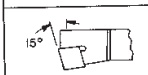
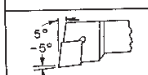
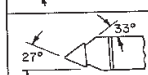

Table 3b. Indexable Insert Holder Application Guide

Tool	Tool Holder Style	Insert Shape	N-Negative P-Positive	Application									
				Rake	Turn	Face	Turn and Face	Turn and Backface	Trace	Groove	Chamfer	Bore	Plane
	A	T	N	•	•							•	
			P	•	•							•	
	A	T	N	•	•			•					
			P	•	•			•					
	A	R	N	•	•	•							•
			P										
	A	R	N	•	•	•			•				•
			P										
	B	T	N	•	•							•	
			P	•	•							•	
	B	T	N	•	•			•				•	
			P	•	•			•				•	
	B	S	N	•	•							•	
			P	•	•							•	
	B	C	N	•	•	•						•	•
			P										

Table 3b. (Continued) Indexable Insert Holder Application Guide

Tool	Tool Holder Style	Insert Shape	Application										
			N-Negative P-Positive		Turn	Face	Turn and Face	Turn and Backface	Trace	Groove	Chamfer	Bore	Plane
			Rake	Turn									
	C	T	N	•	•					•	•		
			P	•	•					•	•		
	D	S	N	•	•	•		•		•	•	•	
			P	•	•	•		•		•	•	•	
	E	T	N	•	•			•	•	•			
			P	•	•			•	•	•			
	F	T	N	•	•							•	
			P	•	•							•	
	G	T	N	•	•							•	
			P	•	•							•	
	G	R	N	•	•	•							
			P	•	•	•							
	G	C	N	•	•	•							
			P	•	•	•							
	H	D	N	•	•			•					
			P										
	J	T	N				•	•					
			P				•	•					
	J	D	N				•	•					
			P										
	J	V	N				•	•					
			P										

Table 3b. (Continued) Indexable Insert Holder Application Guide

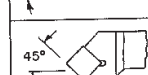
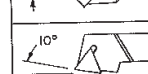
Tool	Tool Holder Style	Insert Shape	Application										
			N-Negative P-Positive		Turn and Face	Turn and Backface	Trace	Groove	Chamfer	Bore	Plane		
			Rake	Turn									
	K	S	N	•	•							•	
			P	•	•								•
	K	C	N	•	•								•
			P										
	L	C	N			•	•						
			P										
	N	T	N	•	•				•				
			P	•	•				•				
	N	D	N	•	•				•				
			P										
	S	S	N	•	•	•			•		•	•	•
			P	•	•	•			•		•	•	•
	W	S	N	•	•								
			P										

**Sintered Carbide Blanks and Cutting Tools.**—As shown in Table 4, American National Standard ANSI B212.1-1984 (R1997) provides standard sizes and designations for eight styles of sintered carbide blanks. These blanks are the unground solid carbide from which either solid or tipped cutting tools are made. Tipped cutting tools are made by brazing a blank onto a shank to produce the cutting tool; these tools differ from carbide insert cutting tools which consist of a carbide insert held mechanically in a tool holder. A typical single-point carbide-tipped cutting tool is shown in the diagram on page 740.

Table 4. American National Standard Sizes and Designations for Carbide Blanks  
ANSI B212.1-1984 (R1997)

T	W	L	Style		T	W	L	Style			
			1000	2000				0000	1000	3000	4000
			Blank Designation					Blank Designation			
1/16	1/16	1/8	1010	2010	1/8	1/8	1/4	0390	1350	3350	4350
1/16	1/16	1/4	1015	2015	1/8	1/8	1/2	0360	1360	3360	4360
1/16	1/16	3/8	1020	2020	1/8	1/8	3/4	0370	1370	3370	4370
1/16	1/16	1/2	1025	2025	1/8	1/8	1	0380	1380	3380	4380
1/16	1/16	3/4	1030	2030	1/8	1/8	1 1/4	0390	1390	3390	4390
1/8	1/8	1/4	1035	2035	1/8	1/8	1/2	0400	1400	3400	4400
1/8	1/8	3/8	1040	2040	1/8	1/8	3/4	0405	1405	3405	4405
1/8	1/8	1/2	1050	2050	1/8	1/8	1	0410	1410	3410	4410
1/8	1/8	3/4	1055	2055	1/8	1/8	1 1/4	0415	1415	3415	4415
1/4	1/4	1/2	1060	2060	1/4	1/4	1/2	0420	1420	3420	4420
1/4	1/4	3/4	1070	2070	1/4	1/4	3/4	0430	1430	3430	4430
1/4	1/4	1	1080	2080	1/4	1/4	1	0440	1440	3440	4440
3/16	3/16	1/2	1090	2090	3/16	3/16	1 1/4	0450	1450	3450	4450
3/16	3/16	3/4	1100	2100	3/16	3/16	1 1/2	0460	1460	3460	4460
3/16	3/16	1	1105	2105	3/16	3/16	1 3/4	0470	1470	3470	4470
1/2	1/2	1/2	1110	2110	1/2	1/2	1 1/2	0475	1475	3475	4475
1/2	1/2	3/4	1120	2120	1/2	1/2	1 3/4	0480	1480	3480	4480
1/2	1/2	1	1130	2130	1/2	1/2	2	0490	1490	3490	4490
1/2	1/2	1 1/4	1140	2140	1/2	1/2	2 1/4	0500	1500	3500	4500
1/2	1/2	1 1/2	1150	2150	1/2	1/2	2 3/4	0510	1510	3510	4510
1/2	1/2	1 3/4	1160	2160	1/2	1/2	3	0515	1515	3515	4515
1/2	1/2	2	1170	2170	1/2	1/2	3 1/4	0520	1520	3520	4520
1/2	1/2	2 1/4	1180	2180	1/2	1/2	3 1/2	0525	1525	3525	4525
1/2	1/2	2 3/4	1190	2190	1/2	1/2	3 3/4	0530	1530	3530	4530
1/2	1/2	3	1200	2200	1/2	1/2	4	0540	1540	3540	4540
1/2	1/2	3 1/4	1210	2210	1/2	1/2	4 1/4	0550	1550	3550	4550
1/2	1/2	3 1/2	1215	2215	1/2	1/2	4 1/2				
3/8	3/8	1/2	1220	2220	3/8	3/8	1/2				
3/8	3/8	3/4	1230	2230	3/8	3/8	3/4	5000	6000	7000	
3/8	3/8	1	1240	2240	3/8	3/8	1	5030	6030	7030	
3/8	3/8	1 1/4	1250	2250	3/8	3/8	1 1/4	...	...	...	7060
3/8	3/8	1 1/2	1260	2260	3/8	3/8	1 1/2	...	...	...	...
3/8	3/8	1 3/4	1270	2270	3/8	3/8	1 3/4	...	...	...	...
3/8	3/8	2	1280	2280	3/8	3/8	2	...	...	...	7170
3/8	3/8	2 1/4	1290	2290	3/8	3/8	2 1/4	...	5200	6200	...
3/8	3/8	2 3/4	1300	2300	3/8	3/8	2 3/4	...	...	...	7230
3/8	3/8	3	1310	2310	3/8	3/8	3	...	5240	6240	...
3/8	3/8	3 1/4	1320	2320	3/8	3/8	3 1/4	...	...	...	...
3/8	3/8	3 1/2	1330	2330	3/8	3/8	3 1/2	...	5340	6340	...
3/8	3/8	3 3/4	1340	2340	3/8	3/8	3 3/4	...	5410	...	...

All dimensions are in inches.  
See diagram on page 740.

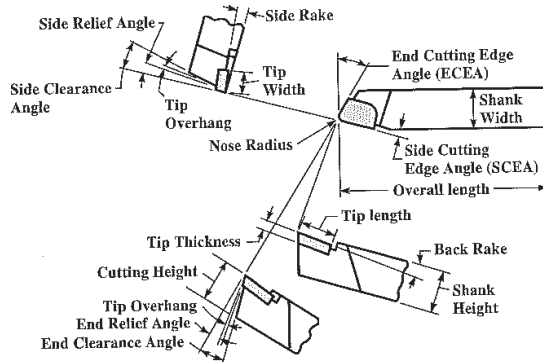

A typical single-point carbide tipped cutting tool. The side rake, side relief, and the clearance angles are normal to the side-cutting edge, rather than the shank, to facilitate its being ground on a tilting-table grinder. The end-relief and clearance angles are normal to the end-cutting edge. The back-rake angle is parallel to the side-cutting edge. The tip of the brazed carbide blank overhangs the shank of the tool by either  $\frac{1}{32}$  or  $\frac{1}{16}$  inch, depending on the size of the tool. For tools in Tables 5, 6, 7, 8, 11 and 12, the maximum overhang is  $\frac{1}{32}$  inch for shank sizes 4, 5, 6, 7, 8, 10, 12 and 44; for other shank sizes in these tables, the maximum overhang is  $\frac{1}{16}$  inch. In Tables 9 and 10 all tools have maximum overhang of  $\frac{1}{32}$  inch.

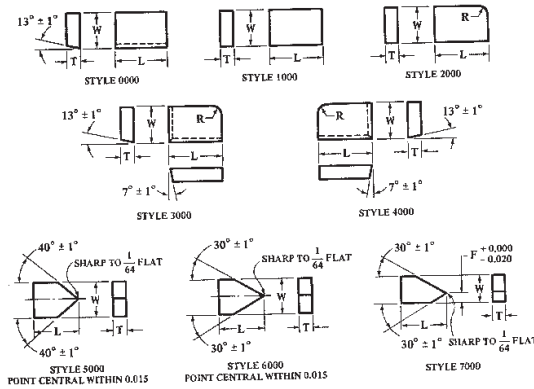

Eight styles of sintered carbide blanks. Standard dimensions for these blanks are given in Table 4.

**Table 5. American National Standard Style A Carbide Tipped Tools**  
ANSI B212.1-1984 (R1997)

Designation		Shank Dimensions			Tip Designation <sup>a</sup>	Tip Dimensions		
Style AR <sup>a</sup>	Style AL <sup>a</sup>	Width A	Height B	Length C		Thickness T	Width W	Length L
Square Shank								
AR 4	AL 4	1/4	1/4	2	2040	3/16	3/16	3/16
AR 5	AL 5	3/16	3/16	2 1/2	2070	3/16	3/16	1/2
AR 6	AL 6	1/8	3/8	2 1/2	2070	3/16	3/16	1/2
AR 7	AL 7	3/16	3/16	3	2070	3/16	1/2	3/8
AR 8	AL 8	1/2	1/2	3 1/2	2170	1/4	3/16	3/8
AR 10	AL 10	3/8	3/8	4	2230	3/16	3/8	3/8
AR 12	AL 12	3/8	3/8	4 1/2	2310	3/16	3/8	15/16
AR 16	AL 16	1	1	6	{ P3390 P4390	3/8	3/8	1
AR 20	AL 20	1 1/4	1 1/4	7	{ P3460 P4460	3/8	3/8	1
AR 24	AL 24	1 1/2	1 1/2	8	{ P3510 P4510	3/8	3/8	1
Rectangular Shank								
AR 44	AL 44	1/2	1	6	P3260	3/16	3/16	3/8
AR 54	AL 54	3/8	1	6	{ P3360 P4360	1/4	3/8	3/4
AR 55	AL 55	3/8	1 1/4	7	{ P3360 P4360	1/4	3/8	3/4
AR 64	AL 64	3/8	1	6	{ P3380 P4380	1/4	1/2	3/4
AR 66	AL 66	3/4	1 1/2	8	{ P3430 P4430	5/16	3/8	15/16
AR 85	AL 85	1	1 1/4	7	{ P3460 P4460	3/8	3/8	1
AR 86	AL 86	1	1 1/2	8	{ P3510 P4510	3/8	3/8	1
AR 88	AL 88	1	2	10	{ P3510 P4510	3/8	3/8	1
AR 90	AL 90	1 1/2	2	10	{ P3540 P4540	1/2	3/4	1 1/2

<sup>a</sup> "A" is straight shank, 0 deg., SCEA (side-cutting-edge angle). "R" is right-cut. "L" is left-cut. Where a pair of tip numbers is shown, the upper number applies to AR tools, the lower to AL tools. All dimensions are in inches.

**Single-Point, Sintered-Carbide-Tipped Tools.**—American National Standard ANSI B212.1-1984 (R1997) covers eight different styles of single-point, carbide-tipped general purpose tools. These styles are designated by the letters A to G inclusive. Styles A, B, F, G, and E with offset point are either right- or left-hand cutting as indicated by the letters R or L. Dimensions of tips and shanks are given in Tables 5 to 11. For dimensions and tolerances not shown, and for the identification system, dimensions, and tolerances of sintered carbide boring tools, see the Standard.



Table 6. American National Standard Style B Carbide Tipped Tools with 15-degree Side-cutting-edge Angle ANSI B212.1-1984 (R1997)

Designation		Shank Dimensions			Tip Designation <sup>a</sup>	Tip Dimensions		
Style BR	Style BL	Width A	Height B	Length C		Thickness T	Width W	Length L
Square Shank								
BR 4	BL 4	1/4	1/4	2	2015	1/16	3/32	1/4
BR 5	BL 5	3/16	3/16	2 1/4	2040	3/32	1/8	1/2
BR 6	BL 6	1/8	3/8	2 1/2	2070	1/16	1/4	1/2
BR 7	BL 7	3/16	3/16	3	2070	3/32	1/4	1/2
BR 8	BL 8	1/2	1/2	3 1/2	2170	1/4	3/16	3/4
BR 10	BL 10	3/8	3/8	4	2230	3/16	3/8	3/4
BR 12	BL 12	3/4	3/4	4 1/2	2310	3/16	3/8	3/4
BR 16	BL 16	1	1	6	3380	1/4	3/8	1
BR 20	BL 20	1 1/4	1 1/4	7	4390	3/8	3/8	1
BR 24	BL 24	1 1/2	1 1/2	8	4460	3/8	3/8	1
					4510	3/8	3/8	1
Rectangular Shank								
BR 44	BL 44	1/2	1	6	2260	3/16	3/16	3/4
BR 54	BL 54	3/8	1	6	3360	1/4	3/8	3/4
BR 55	BL 55	3/8	1 1/4	7	4360	1/4	3/8	3/4
BR 64	BL 64	3/4	1	6	3380	1/2	1/2	3/4
BR 66	BL 66	3/4	1 1/2	8	4380	3/16	3/16	1 1/8
BR 85	BL 85	1	1 1/4	7	3420	3/16	3/8	1
BR 86	BL 86	1	1 1/2	8	4430	3/16	3/8	1
BR 88	BL 88	1	2	10	4460	3/8	3/8	1
BR 90	BL 90	1 1/2	2	10	3510	1/2	3/4	1 1/4
					4540	1/2	3/4	1 1/4

<sup>a</sup> Where a pair of tip numbers is shown, the upper number applies to BR tools, the lower to BL tools. All dimensions are in inches.

A number follows the letters of the tool style and hand designation and for square shank tools, represents the number of sixteenths of an inch of width, *W*, and height, *H*. With rectangular shanks, the first digit of the number indicates the number of eighths of an inch in the shank width, *W*, and the second digit the number of quarters of an inch in the shank height, *H*. One exception is the 1 1/2 x 2-inch size which has been arbitrarily assigned the number 90.

**Table 7. American National Standard Style C Carbide Tipped Tools**  
ANSI B212.1-1984 (R1997)

Designation	Shank Dimensions			Tip Designation	Tip Dimensions		
	Width A	Height B	Length C		Thickness T	Width W	Length L
C 4	1/4	1/2	2	1030	1/16	1/4	3/16
C 5	3/16	5/16	2 1/2	1080	3/32	3/8	3/8
C 6	3/8	3/4	2 1/2	1090	3/32	3/8	3/8
C 7	7/16	7/8	3	1105	3/32	7/16	1/2
C 8	1/2	1 1/2	3 1/2	1200	1/2	1 1/2	1 1/2
C 10	5/8	5/4	4	1240	5/8	5/8	5/8
C 12	3/4	3/2	4 1/2	1340	3/8	3/4	3/4
C 16	1	1	6	1410	1/2	1	1 1/4
C 20	1 1/4	1 1/4	7	1480	5/8	1 1/4	1 3/4
C 44	1/2	1	6	1320	3/16	1/2	1/2
C 54	5/8	1	6	1400	1/2	3/4	3/4
C 55	3/4	1 1/4	7	1400	1/2	3/4	3/4
C 64	3/4	1	6	1405	1/2	3/4	3/4
C 66	3/4	1 1/2	8	1470	3/8	3/4	3/4
C 86	1	1 1/2	8	1475	3/8	1	3/4

All dimensions are in inches. Square shanks above horizontal line; rectangular below.

**Table 8. American National Standard Style D, 80-degree Nose-angle Carbide Tipped Tools**  
ANSI B212.1-1984 (R1997)

Designation	Shank Dimensions			Tip Designation	Tip Dimensions		
	Width A	Height B	Length C		Thickness T	Width W	Length L
D 4	1/4	1/2	2	5030	1/16	1/4	3/16
D 5	3/16	5/16	2 1/4	5080	3/32	3/8	3/8
D 6	3/8	3/4	2 1/2	5100	3/32	3/8	3/8
D 7	7/16	7/8	3	5105	3/32	7/16	1/2
D 8	1/2	1 1/2	3 1/2	5200	1/2	1 1/2	1 1/2
D 10	5/8	5/4	4	5240	5/8	5/8	5/8
D 12	3/4	3/2	4 1/2	5340	3/8	3/4	3/4
D 16	1	1	6	5410	1/2	1	1 1/4

All dimensions are in inches.

Table 9. American National Standard Style E, 60-degree Nose-angle, Carbide Tipped Tools ANSI B212.1-1984 (R1997)

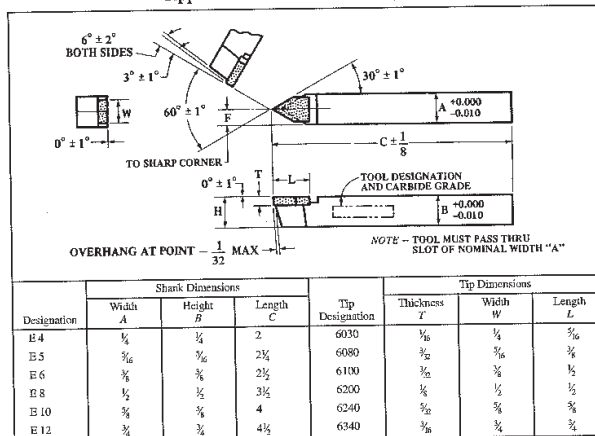

All dimensions are in inches.

Table 10. American National Standard Styles ER and EL, 60-degree Nose-angle, Carbide Tipped Tools with Offset Point ANSI B212.1-1984 (R1997)

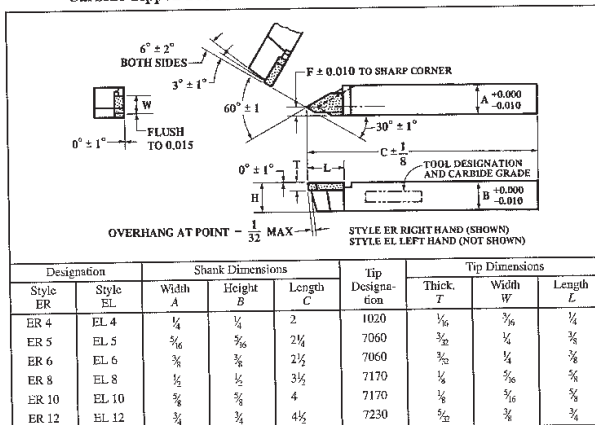

All dimensions are in inches.

**Table 11. American National Standard Style F, Offset, End-cutting Carbide Tipped Tools ANSI B212.1-1984 (R1997)**

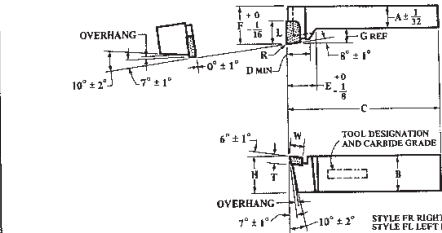

Designation		Shank Dimensions					Tip Designation	Tip Dimensions		
Style FR	Style FL	Width A	Height B	Length C	Offset G	Length of Offset E		Thick-ness T	Width W	Length L
Square Shank										
FR 8	FL 8	1/2	1/2	3 1/2	1/4	3/8	{ P4170 P3170	3/16	3/16	3/8
FR 10	FL 10	3/8	3/8	4	3/8	1	{ P1230 P3230	3/32	3/8	3/4
FR 12	FL 12	3/4	3/4	4 1/2	3/8	1 1/8	{ P4310 P3310	3/16	7/16	1 1/16
FR 16	FL 16	1	1	6	3/4	1 3/8	{ P4390 P3390	1/4	3/8	1
FR 20	FL 20	1 1/4	1 1/4	7	3/4	1 1/2	{ P4460 P3460	3/16	3/8	1
FR 24	FL 24	1 1/2	1 1/2	8	3/4	1 1/2	{ P4510 P3510	3/8	3/8	1
Rectangular Shank										
FR 44	FL 44	1/2	1	6	1/2	3/8	{ P4260 P1260	3/16	3/16	3/4
FR 55	FL 55	3/8	1 1/4	7	3/8	1 1/8	{ P4360 P3360	1/4	3/8	3/4
FR 64	FL 64	3/4	1	6	3/8	1 1/16	{ P4380 P3380	1/4	1/2	3/4
FR 66	FL 66	3/4	1 1/2	8	3/4	1 1/4	{ P4430 P3430	3/16	7/16	1 1/16
FR 85	FL 85	1	1 1/4	7	3/4	1 1/2	{ P4460 P3460	3/16	3/8	1
FR 86	FL 86	1	1 1/2	8	3/4	1 1/2	{ P4510 P3510	3/8	3/8	1
FR 90	FL 90	1 1/2	2	10	3/4	1 3/8	{ P4540 P3540	1/2	3/4	1 1/4

All dimensions are in inches. Where a pair of tip numbers is shown, the upper number applies to FR tools, the lower number to FL tools.

**Single-point Tool Nose Radii.**—The tool nose radii recommended in the American National Standard are as follows: For square-shank tools up to and including 3/8-inch square tools, 1/16 inch; for those over 3/8-inch square through 1 1/4-inches square, 1/32 inch; and for those above 1 1/4-inches square, 1/16 inch. For rectangular-shank tools with shank section of 1/2 x 1 inch through 1 x 1 1/2 inches, the nose radii are 1/32 inch, and for 1 x 2 and 1 1/2 x 2 inch shanks, the nose radius is 1/16 inch.

**Single-point Tool Angle Tolerances.**—The tool angles shown on the diagrams in the Tables 5 through 11 are general recommendations. Tolerances applicable to these angles are  $\pm 1$  degree on all angles except end and side clearance angles; for these the tolerance is  $\pm 2$  degrees.

**Table 12. American National Standard Style G, Offset, Side-cutting, Carbide Tipped Tools ANSI B212.1-1984 (R1997)**

Designation		Shank Dimensions					Tip Designation	Tip Dimensions		
Style GR	Style GL	Width A	Height B	Length C	Offset G	Length of Offset E		Thickness T	Width W	Length L
Square Shank										
GR 8	GL 8	1/2	1/2	3 1/2	1/4	1 1/8	{ P3170 P4170	1/8	3/16	3/8
GR 10	GL 10	5/8	5/8	4	3/8	1 3/8	{ P3230 P4230	5/16	3/8	3/4
GR 12	GL 12	3/4	3/4	4 1/2	3/8	1 1/2	{ P3310 P2310	3/8	7/16	13/16
GR 16	GL 16	1	1	6	1/2	1 7/8	{ P3390 P4390	1/2	3/8	1
GR 20	GL 20	1 1/4	1 1/4	7	3/4	1 9/8	{ P3460 P4460	3/8	3/8	1
GR 24	GL 24	1 1/2	1 1/2	8	3/4	1 7/8	{ P3510 P4510	3/8	3/8	1
Rectangular Shank										
GR 44	GL 44	1/2	1	6	1/4	1 1/8	{ P3260 P4260	3/8	5/8	3/8
GR 55	GL 55	3/8	1 1/4	7	3/8	1 3/8	{ P3360 P4360	1/2	3/8	3/4
GR 64	GL 64	3/4	1	6	1/2	1 3/8	{ P3380 P4380	1/2	1/2	3/4
GR 66	GL 66	3/4	1 1/2	8	1/2	1 3/8	{ P3430 P4430	5/8	3/8	15/16
GR 85	GL 85	1	1 1/4	7	1/2	1 1/2	{ P3460 P4460	5/8	5/8	1
GR 86	GL 86	1	1 1/2	8	1/2	1 1/2	{ P3510 P4510	3/8	3/8	1
GR 90	GL 90	1 1/2	2	10	3/4	2 1/8	{ P3540 P4540	1/2	3/4	1 1/2

All dimensions are in inches. Where a pair of tip numbers is shown, the upper number applies to GR tools, the lower number to GL tools.

## CEMENTED CARBIDES

### Cemented Carbides and Other Hard Materials

**Carbides and Carbonitrides.**—Though high-speed steel retains its importance for such applications as drilling and broaching, most metal cutting is carried out with carbide tools. For materials that are very difficult to machine, carbide is now being replaced by carbonitrides, ceramics, and superhard materials. Cemented (or sintered) carbides and carbonitrides, known collectively in most parts of the world as hard metals, are a range of very hard, refractory, wear-resistant alloys made by powder metallurgy techniques. The minute carbide or nitride particles are "cemented" by a binder metal that is liquid at the sintering temperature. Compositions and properties of individual hardmetals can be as different as those of brass and high-speed steel.

All hardmetals are *cermets*, combining ceramic particles with a metallic binder. It is unfortunate that (owing to a mistranslation) the term *cermet* has come to mean either all hardmetals with a titanium carbide (TiC) base or simply cemented titanium carbonitrides. Although no single element other than carbon is present in all hardmetals, it is no accident that the generic term is "tungsten carbide." The earliest successful grades were based on carbon, as are the majority of those made today, as listed in Table 1.

The outstanding machining capabilities of high-speed steel are due to the presence of very hard carbide particles, notably tungsten carbide, in the iron-rich matrix. Modern methods of making cutting tools from pure tungsten carbide were based on this knowledge. Early pieces of cemented carbide were much too brittle for industrial use, but it was soon found that mixing tungsten carbide powder with up to 10 per cent of metals such as iron, nickel, or cobalt, allowed pressed compacts to be sintered at about 1500°C to give a product with low porosity, very high hardness, and considerable strength. This combination of properties made the materials ideally suitable for use as tools for cutting metal.

Cemented carbides for cutting tools were introduced commercially in 1927, and although the key discoveries were made in Germany, many of the later developments have taken place in the United States, Austria, Sweden, and other countries. Recent years have seen two "revolutions" in carbide cutting tools, one led by the United States and the other by Europe. These were the change from brazed to clamped carbide inserts and the rapid development of coating technology.

When indexable tips were first introduced, it was found that so little carbide was worn away before they were discarded that a minor industry began to develop, regrinding the so-called "throwaway" tips and selling them for reuse in adapted toolholders. Hardmetal consumption, which had grown dramatically when indexable inserts were introduced, leveled off and began to decline. This situation was changed by the advent and rapid acceptance of carbide, nitride, and oxide coatings. Application of an even harder, more wear-resistant surface to a tougher, more shock-resistant substrate allowed production of new generations of longer-lasting inserts. Regrinding destroyed the enhanced properties of the coatings, so was abandoned for coated tooling.

Brazed tools have the advantage that they can be reground over and over again, until almost no carbide is left, but the tools must always be reset after grinding to maintain machining accuracy. However, all brazed tools suffer to some extent from the stresses left by the brazing process, which in unskilled hands or with poor design can shatter the carbide even before it has been used to cut metal. In present conditions it is cheaper to use indexable inserts, which are tool tips of precise size, clamped in similarly precise holders, needing no time-consuming and costly resetting but usable only until each cutting edge or corner has lost its initial sharpness (see *Indexable Inserts* and related topics starting on page 730 and *Indexable Insert Holders for NC* on page 1280). The absence of brazing stresses and the "one-use" concept also means that harder, longer-lasting grades can be used.

**Table 1. Typical Properties of Tungsten-Carbide-Based Cutting-Tool Hardmetals**

ISO Application Code	Composition (%)				Density	Hardness	Transverse Rupture Strength (N/mm <sup>2</sup> )
	WC	TiC	TaC	Co			
P01	50	35	7	6	8.5	1900	1100
P05	78	16		6	11.4	1820	1300
P10	69	15	8	8	11.5	1740	1400
P15	78	12	3	7	11.7	1660	1500
P20	79	8	5	8	12.1	1580	1600
P25	82	6	4	8	12.9	1530	1700
P30	84	5	2	9	13.3	1490	1850
P40	85	5		10	13.4	1420	1950
P50	78	3	3	16	13.1	1250	2300
M10	85	5	4	6	13.4	1590	1800
M20	82	5	5	8	13.3	1540	1900
M30	86	4		10	13.6	1440	2000
M40	84	4	2	10	14.0	1380	2100
K01	97			3	15.2	1850	1450
K05	95		1	4	15.0	1790	1550
K10	92		2	6	14.9	1730	1700
K20	94			6	14.8	1650	1950
K30	91			9	14.4	1400	2250
K40	89			11	14.1	1320	2500

A complementary development was the introduction of ever-more complex chip-breakers, derived from computer-aided design and pressed and sintered to precise shapes and dimensions. Another advance was the application of hot isostatic pressing (HIP), which has moved hardmetals into applications that were formerly uneconomic. This method allows virtually all residual porosity to be squeezed out of the carbide by means of inert gas at high pressure, applied at about the sintering temperature. Toughness, rupture strength, and shock resistance can be doubled or tripled by this method, and the reject rates of very large sintered components are reduced to a fraction of their previous levels.

Further research has produced a substantial number of excellent cutting-tool materials based on titanium carbonitride. Generally called "cermets," as noted previously, carbonitride-based cutting inserts offer excellent performance and considerable prospects for the future.

*Compositions and Structures:* Properties of hardmetals are profoundly influenced by microstructure. The microstructure in turn depends on many factors including basic chemical composition of the carbide and matrix phases; size, shape, and distribution of carbide particles; relative proportions of carbide and matrix phases; degree of intersolubility of carbides; excess or deficiency of carbon; variations in composition and structure caused by diffusion or segregation; production methods generally, but especially milling, carburizing, and sintering methods, and the types of raw materials; post sintering treatments such as hot isostatic pressing; and coatings or diffusion layers applied after initial sintering.

*Tungsten Carbide/Cobalt (WC/Co):* The first commercially available cemented carbides consisted of fine angular particles of tungsten carbide bonded with metallic cobalt. Intended initially for wire-drawing dies, this composition type is still considered to have

the greatest resistance to simple abrasive wear and therefore to have many applications in machining.

For maximum hardness to be obtained from closeness of packing, the tungsten carbide grains should be as small as possible, preferably below 1  $\mu\text{m}$  (swaging 0.00004 in.) and considerably less for special purposes. Hardness and abrasion resistance increase as the cobalt content is lowered, provided that a minimum of cobalt is present (2 per cent can be enough, although 3 per cent is the realistic minimum) to ensure complete sintering. In general, as carbide grain size or cobalt content or both are increased—frequently in unison—tougher and less hard grades are obtained. No porosity should be visible, even under the highest optical magnification.

WC/Co compositions used for cutting tools range from about 2 to 13 per cent cobalt, and from less than 0.5 to more than 5  $\mu\text{m}$  (0.00002–0.0002 in.) in grain size. For stamping tools, swaging dies, and other wear applications for parts subjected to moderate or severe shock, cobalt content can be as much as 30 per cent, and grain size a maximum of about 10  $\mu\text{m}$  (0.0004 in.). In recent years, "micrograin" carbides, combining submicron (less than 0.00004 in.) carbide grains with relatively high cobalt content have found increasing use for machining at low speeds and high feed rates. An early use was in high-speed wood-working cutters such as are used for planing.

For optimum properties, porosity should be at a minimum, carbide grain size as regular as possible, and carbon content of the tungsten carbide phase close to the theoretical (stoichiometric) value. Many tungsten carbide/cobalt compositions are modified by small but important additions—from 0.5 to perhaps 3 per cent of tantalum, niobium, chromium, vanadium, titanium, hafnium, or other carbides. The basic purpose of these additions is generally inhibition of grain growth, so that a consistently fine structure is maintained.

*Tungsten-Titanium Carbide/Cobalt (WC/TiC/Co):* These grades are used for tools to cut steels and other ferrous alloys, the purpose of the TiC content being to resist the high-temperature diffusive attack that causes chemical breakdown and cratering. Tungsten carbide diffuses readily into the chip surface, but titanium carbide is extremely resistant to such diffusion. A solid solution or "mixed crystal" of WC in TiC retains the anticratering property to a great extent.

Unfortunately, titanium carbide and TiC-based solid solutions are considerably more brittle and less abrasion resistant than tungsten carbide. TiC content, therefore, is kept as low as possible, only sufficient TiC being provided to avoid severe cratering wear. Even 2 or 3 per cent of titanium carbide has a noticeable effect, and as the relative content is substantially increased, the cratering tendency becomes more severe.

In the limiting formulation the carbide is tungsten-free and based entirely on TiC, but generally TiC content extends to no more than about 18 per cent. Above this figure the carbide becomes excessively brittle and is very difficult to braze, although this drawback is not a problem with throwaway inserts.

WC/TiC/Co grades generally have two distinct carbide phases, angular crystals of almost pure WC and rounded TiC/WC mixed crystals. Among progressive manufacturers, although WC/TiC/Co hardmetals are very widely used, in certain important respects they are obsolescent, having been superseded by the WC/TiC/Ta(Nb)C/Co series in the many applications where higher strength combined with crater resistance is an advantage. TiC, TiN, and other coatings on tough substrates have also diminished the attractions of high-TiC grades for high-speed machining of steels and ferrous alloys.

*Tungsten-Titanium-Tantalum (-Niobium) Carbide/Cobalt:* Except for coated carbides, tungsten-titanium-tantalum (-niobium) grades could be the most popular class of hardmetals. Used mainly for cutting steel, they combine and improve upon most of the best features of the longer-established WC/TiC/Co compositions. These carbides compete directly with carbonitrides and silicon nitride ceramics, and the best cemented carbides of this class can undertake very heavy cuts at high speeds on all types of steels, including austenitic stain-



less varieties. These tools also operate well on ductile cast irons and nickel-base superalloys, where great heat and high pressures are generated at the cutting edge. However, they do not have the resistance to abrasive wear possessed by micrograin straight tungsten carbide grades nor the good resistance to cratering of coated grades and titanium carbide-based cermets.

*Titanium Carbide/Molybdenum/Nickel (TiC/Mo/Ni):* The extreme indentation hardness and crater resistance of titanium carbide, allied to the cheapness and availability of its main raw material (titanium dioxide,  $TiO_2$ ), provide a strong inducement to use grades based on this carbide alone. Although developed early in the history of hardmetals, these carbides were difficult to braze satisfactorily and consequently were little used until the advent of clamped, throwaway inserts. Moreover, the carbides were notoriously brittle and could take only fine cuts in minimal-shock conditions.

Titanium-carbide-based grades again came into prominence about 1960, when nickel-molybdenum began to be used as a binder instead of nickel. The new grades were able to perform a wider range of tasks including interrupted cutting and cutting under shock conditions.

The very high indentation hardness values recorded for titanium carbide grades are not accompanied by correspondingly greater resistance to abrasive wear, the apparently less hard tungsten carbide being considerably superior in this property. Moreover, carbonitrides, advanced tantalum-containing multicarbides, and coated variants generally provide better all-round cutting performances.

*Titanium-Base Carbonitrides:* Development of titanium-carbonitride-based cutting-tool materials predates the use of coatings of this type on more conventional hardmetals by many years. Appreciable, though uncontrolled, amounts of carbonitride were often present, if only by accident, when cracked ammonia was used as a less expensive substitute for hydrogen in some stages of the production process in the 1950's and perhaps for two decades earlier.

Much of the recent, more scientific development of this class of materials has taken place in the United States, particularly by Teledyne Firth Sterling with its  $SD_3$  grade and in Japan by several companies. Many of the compositions currently in use are extremely complex, and their structures—even with apparently similar compositions—can vary enormously. For instance, Mitsubishi characterizes its Himet NX series of cermets as  $TiC/WC/Ta(Nb)C/Mo_2C/TiN/Ni/Co/Al$ , with a structure comprising both large and medium-size carbide particles (mainly TiC according to the quoted density) in a superalloy-type matrix containing an aluminum-bearing intermetallic compound.

*Steel- and Alloy-Bonded Titanium Carbide:* The class of material exemplified by Ferro-Tic, as it is known, consists primarily of titanium carbide bonded with heat-treatable steel, but some grades also contain tungsten carbide or are bonded with nickel- or copper-base alloys. These cemented carbides are characterized by high binder contents (typically 50–60 per cent by volume) and lower hardnesses, compared with the more usual hardmetals, and by the great variation in properties obtained by heat treatment.

In the annealed condition, steel-bonded carbides have a relatively soft matrix and can be machined with little difficulty, especially by CBN (superhard cubic boron nitride) tools. After heat treatment, the degree of hardness and wear resistance achieved is considerably greater than that of normal tool steels, although understandably much less than that of traditional sintered carbides. Microstructures are extremely varied, being composed of 40–50 per cent TiC by volume and a matrix appropriate to the alloy composition and the stage of heat treatment. Applications include stamping, blanking and drawing dies, machine components, and similar items where the ability to machine before hardening reduces production costs substantially.

*Coating:* As a final stage in carbide manufacture, coatings of various kinds are applied mainly to cutting tools, where for cutting steel in particular it is advantageous to give the

rank and clearance surfaces characteristics that are quite different from those of the body of the insert. Coatings of titanium carbide, nitride, or carbonitride; of aluminum oxide; and of other refractory compounds are applied to a variety of hardmetal substrates by chemical or physical vapor deposition (CVD or PVD) or by newer plasma methods.

The most recent types of coatings include hafnium, tantalum, and zirconium carbides and nitrides; alumina/titanium oxide; and multiple carbide/carbonitride/nitride/oxide, oxynitride or oxycarbonitride combinations. Greatly improved properties have been claimed for variants with as many as 13 distinct CVD coatings. A markedly sharper cutting edge compared with other CVD-coated hardmetals is claimed, permitting finer cuts and the successful machining of soft but abrasive alloys.

The keenest edges on coated carbides are achieved by the techniques of physical vapor deposition. In this process, ions are deposited directionally from the electrodes, rather than evenly on all surfaces, so the sharpness of cutting edges is maintained and may even be enhanced. PVD coatings currently available include titanium nitride and carbonitride, their distinctive gold color having become familiar throughout the world on high-speed steel tooling. The high temperatures required for normal CVD tends to soften heat-treated high-speed steel. PVD-coated hardmetals have been produced commercially for several years, especially for precision milling inserts.

Recent developments in extremely hard coatings, generally involving exotic techniques, include boron carbide, cubic boron nitride, and pure diamond. Almost the ultimate in wear resistance, the commercial applications of thin plasma-generated diamond surfaces at present are mainly in manufacture of semiconductors, where other special properties are important.

For cutting tools the substrate is of equal importance to the coating in many respects, its critical properties including fracture toughness (resistance to crack propagation), elastic modulus, resistance to heat and abrasion, and expansion coefficient. Some manufacturers are now producing inserts with graded composition, so that structures and properties are optimized at both surface and interior, and coatings are less likely to crack or break away.

*Specifications:* Compared with other standardized materials, the world of sintered hardmetals is peculiar. For instance, an engineer who seeks a carbide grade for the finish-machining of a steel component may be told to use *ISO Standard Grade P10* or *Industry Code C7*. If the composition and nominal properties of the designated tool material are then requested, the surprising answer is that, in basic composition alone, the tungsten carbide content of P10 (or of the now superseded C7) can vary from zero to about 75, titanium carbide from 8 to 80, cobalt 0 to 10, and nickel 0 to 15 per cent. There are other possible constituents, also, in this so-called standard alloy, and many basic properties can vary as much as the composition. All that these dissimilar materials have in common, and all that the so-called standards mean, is that their suppliers—and sometimes their suppliers alone—consider them suitable for one particular and ill-defined machining application (which for P10 or C7 is the finish machining of steel).

This peculiar situation arose because the production of cemented carbides in occupied Europe during World War II was controlled by the German Hartmetallzentrale, and no factory other than Krupp was permitted to produce more than one grade. By the end of the war, all German-controlled producers were equipped to make the G, S, H, and F series to German standards. In the postwar years, this series of carbides formed the basis of unofficial European standardization. With the advent of the newer multicarbides, the previous identities of grades were gradually lost. The applications relating to the old grades were retained, however, as a new German DIN standard, eventually being adopted, in somewhat modified form, by the International Standards Organization (ISO) and by ANSI in the United States.

The American cemented carbides industry developed under diverse ownership and solid competition. The major companies actively and independently developed new varieties of hardmetals, and there was little or no standardization, although there were many attempts

to compile equivalent charts as a substitute for true standardization. Around 1942, the Buick division of GMC produced a simple classification code that arranged nearly 100 grades derived from 10 manufacturers under only 14 symbols (TC-1 to TC-14). In spite of serious deficiencies, this system remained in use for many years as an American industry standard; that is, Buick TC-1 was equivalent to industry code C1. Buick itself went much further, using the tremendous influence, research facilities, and purchasing potential of its parent company to standardize the products of each carbide manufacturer by properties that could be tested, rather than by the indeterminate recommended applications. Many large-scale carbide users have developed similar systems in attempts to exert some degree of in-house standardization and quality control. Small and medium-sized users, however, still suffer from so-called industry standards, which only provide a starting point for grade selection.

ISO standard 513, summarized in Table 2, divides all machining grades into three color-coded groups: straight tungsten carbide grades (letter K, color red) for cutting gray cast iron, nonferrous metals, and nonmetallics; highly alloyed grades (letter P, color blue) for machining steel; and less alloyed grades (letter M, color yellow, generally with less TiC than the corresponding P series), which are multipurpose and may be used on steels, nickel-base superalloys, ductile cast irons, and so on. Each grade within a group is also given a number to represent its position in a range from maximum hardness to maximum toughness (shock resistance). Typical applications are described for grades at more or less regular numerical intervals. Although coated grades scarcely existed when the ISO standard was prepared, it is easy to classify coated as uncoated carbides—or carbonitrides, ceramics, and superhard materials—according to this system.

In this situation, it is easy to see how one plant will prefer one manufacturer's carbide and a second plant will prefer that of another. Each has found the carbide most nearly ideal for the particular conditions involved. In these circumstances it pays each manufacturer to make grades that differ in hardness, toughness, and crater resistance, so that they can provide a product that is near the optimum for a specific customer's application.

Although not classified as a hard metal, new particle or powder metallurgical methods of manufacture, coupled with new coating technology have led in recent years to something of an upsurge in the use of high speed steel. Lower cost is a big factor, and the development of such coatings as titanium nitride, cubic boron nitride, and pure diamond, has enabled some high speed steel tools to rival tools made from tungsten and other carbides in their ability to maintain cutting accuracy and prolong tool life. Multiple layers may be used to produce optimum properties in the coating, with adhesive strength where there is contact with the substrate, combined with hardness at the cutting surface to resist abrasion. Total thickness of such coating, even with multiple layers, is seldom more than 15 microns (0.000060 in.).

*Importance of Correct Grades:* A great diversity of hardmetal types is required to cope with all possible combinations of metals and alloys, machining operations, and working conditions. Tough, shock-resistant grades are needed for slow speeds and interrupted cutting, harder grades for high-speed finishing, heat-resisting alloyed grades for machining superalloys, and crater-resistant compositions, including most of the many coated varieties, for machining steels and ductile iron.

**Ceramics.**—Moving up the hardness scale, ceramics provide increasing competition for cemented carbides, both in performance and in cost-effectiveness, though not yet in reliability. Hardmetals themselves consist of ceramics—nonmetallic refractory compounds, usually carbides or carbonitrides—with a metallic binder of much lower melting point. In such systems, densification generally takes place by liquid-phase sintering. Pure ceramics have no metallic binder, but may contain lower-melting-point compounds or ceramic mixtures that permit liquid-phase sintering to take place. Where this condition is not possible, hot pressing or hot isostatic pressing can often be used to make a strong, relatively pore-

Table 2. ISO Classifications of Hardmetals (Cemented Carbides and Carbonitrides) by Application

Major Types of Chip Removal Symbol and Color	Broad Categories of Materials to be Machined	Designation (Group)	Groups of Applications		Direction of Decrease in Characteristics					
			Specific Material to be Machined	Use and Working Conditions	of cut ↑ speed ↓ wear	of carbide ↑ toughness ↓				
P Blue	Ferrous metals with long or long chips	P10	Steel, steel castings	Finish turning and boring; high cutting speeds; small chip sections, accurate dimensions; fine finish, minimum surface roughness	↑ speed ↓ wear	↑ carbide ↑ toughness ↓				
		P15	Steel, steel castings	Turning, coping, threading, milling; high cutting speeds; small or medium chip sections						
		P20	Steel, steel castings, ductile cast iron with long chips	Turning, coping, milling; medium cutting speeds and chip sections, planing with small chip sections						
		P30	Steel, steel castings, ductile cast iron with long chips	Turning, milling, planing; medium or large chip sections, unfavorable machining conditions						
		P40	Steel, steel castings with sand inclusions and cavities	Turning, planing, slotting; low cutting speeds, large chip sections, with possible large cutting angles, unfavorable cutting conditions, and work on automatic machines						
M Yellow	Ferrous metals with long or short chips, and non-ferrous metals	P50	Steel, steel castings of medium or low tensile strength, with sand inclusions and cavities	Operation on automatic lathes; rough cutting; turning, planing, slotting; low cutting speeds, large chip sections, with possible large cutting angles, unfavorable conditions and work on automatic machines	↑ speed ↓ wear	↑ carbide ↑ toughness ↓				
		M10	Steel, steel castings, manganese steel, gray cast iron, alloy cast iron	Turning, milling, planing; medium cutting speeds and chip sections						
		M20	Steel, steel castings, austenitic or manganese steel, gray cast iron	Turning, milling, planing; medium cutting speeds, medium or large chip sections						
		M30	Steel, steel castings, austenitic steel, any cast iron, high-temperature-resistant alloys	Turning, planing, off; particularly on automatic machines						
		M40	Mild, free-cutting steel, low-temper steel, non-ferrous metals and light alloys	Turning, finish turning, boring, milling, scraping						
		K Red	Ferrous metals with short chips, non-ferrous metals and non-metallic materials	K10			Very hard gray cast iron, chilled cast iron, cast steel, cast iron, high-temperature-resistant alloys, ferrous metals and light alloys	Turning, milling, planing; medium cutting speeds, medium or large chip sections	↑ speed ↓ wear	↑ carbide ↑ toughness ↓
				K20			Gray cast iron over 220 Brinell, malleable cast iron with short chips, hardened steel, silicon-aluminum and copper alloys, cast iron, cast steel, cast aluminum, cast magnesium, cast copper, cast brass, cast nickel, cast titanium, cast titanium alloys, hardened steel, highly abrasive plastics, hard cast-iron, ceramics	Turning, milling, drilling, boring, broaching, slotting		
K30	Low-hardness gray cast iron, low-tensile steel, compressed wood			Turning, milling, planing, slotting, unfavorable conditions, and possibility of large cutting angles						
K40	Softwood or hard wood, non-ferrous metals			Turning, milling, planing, slotting, unfavorable conditions, and possibility of large cutting angles						

free component or cutting insert. This section is restricted to those ceramics that compete directly with hardmetals, mainly in the cutting-tool category as shown in Table 3.

Ceramics are hard, completely nonmetallic substances that resist heat and abrasive wear. Increasingly used as clamped indexable tool inserts, ceramics differ significantly from tool steels, which are completely metallic. Ceramics also differ from cermets such as cemented carbides and carbonitrides, which comprise minute ceramic particles held together by metallic binders.

Table 3. Typical Properties of Cutting Tool Ceramics

Group	Alumina	Alumina/TC	Silicon Nitride	PCD	PCBN
Typical composition types	Al <sub>2</sub> O <sub>3</sub> or Al <sub>2</sub> O <sub>3</sub> /ZrO <sub>2</sub>	70/30 Al <sub>2</sub> O <sub>3</sub> /TiC	Si <sub>3</sub> N <sub>4</sub> /Y <sub>2</sub> O <sub>3</sub> plus		
Density (g/cm <sup>3</sup> )	4.0	4.25	3.27	3.4	3.1
Transverse rupture strength (N/mm <sup>2</sup> )	700	750	800		800
Compressive strength (kN/mm <sup>2</sup> )	4.0	4.5	4.0	4.7	3.8
Hardness (HV)	1750	1800	1600		
Hardness HK (kN/mm <sup>2</sup> )				50	28
Young's modulus (kN/mm <sup>2</sup> )	380	370	300	925	680
Modulus of rigidity (kN/mm <sup>2</sup> )	150	160	150	430	280
Poisson's ratio	0.24	0.22	0.20	0.09	0.22
Thermal expansion coefficient (10 <sup>-6</sup> /K)	8.5	7.8	3.2	3.8	4.9
Thermal conductivity (W/m·K)	23	17	22	120	100
Fracture toughness (K <sub>IC</sub> , MN/m <sup>3/2</sup> )	2.3	3.3	5.0	7.9	10

Alumina-based ceramics were introduced as cutting inserts during World War II, and were for many years considered too brittle for regular machine-shop use. Improved machine tools and finer-grain, tougher compositions incorporating zirconia or silicon carbide "whiskers" now permit their use in a wide range of applications. Silicon nitride, often combined with alumina (aluminum oxide), yttria (yttrium oxide), and other oxides and nitrides, is used for much of the high-speed machining of superalloys, and newer grades have been formulated specifically for cast iron—potentially a far larger market.

In addition to improvements in toolholders, great advances have been made in machine tools, many of which now feature the higher powers and speeds required for the efficient use of ceramic tooling. Brittleness at the cutting edge is no longer a disadvantage, with the improvements made to the ceramics themselves, mainly in toughness, but also in other critical properties.

Although very large numbers of useful ceramic materials are now available, only a few combinations have been found to combine such properties as minimum porosity, hardness, wear resistance, chemical stability, and resistance to shock to the extent necessary for cutting-tool inserts. Most ceramics used for machining are still based on high-purity, fine-grained alumina (aluminum oxide), but embody property-enhancing additions of other ceramics such as zirconia (zirconium oxide), titania (titanium oxide), titanium carbide, tungsten carbide, and titanium nitride. For commercial purposes, those more commonly used are often termed "white" (alumina with or without zirconia) or "black" (roughly 70/30 alumina/titanium carbide). More recent developments are the distinctively green alumina ceramics strengthened with silicon carbide whiskers and the brown-tinged silicon nitride types.

Ceramics benefit from hot isostatic pressing, used to remove the last vestiges of porosity and raise substantially the material's shock resistance, even more than carbide-based hardmetals. Significant improvements are derived by even small parts such as tool inserts, although, in principle, they should not need such treatment if raw materials and manufacturing methods are properly controlled.

*Oxide Ceramics:* Alumina cutting tips have extreme hardness—more than HV 2000 or HRA 94—and give excellent service in their limited but important range of uses such as

the machining of chilled iron rolls and brake drums. A substantial family of alumina-based materials has been developed, and fine-grained alumina-based composites now have sufficient strength for milling cast iron at speeds up to 2500 ft/min (800 m/min). Resistance to cratering when machining steel is exceptional.

*Oxide/Carbide Ceramics:* A second important class of alumina-based cutting ceramics combines aluminum oxide or alumina-zirconia with a refractory carbide or carbides, nearly always 30 per cent TiC. The compound is black and normally is hot pressed or hot isostatically pressed (HIPed). As shown in Table 3, the physical and mechanical properties of this material are generally similar to those of the pure alumina ceramics, but strength and shock resistance are generally higher, being comparable with those of higher-toughness simple alumina-zirconia grades. Current commercial grades are even more complex, combining alumina, zirconia, and titanium carbide with the further addition of titanium nitride.

*Silicon Nitride Base:* One of the most effective ceramic cutting-tool materials developed in the UK is Syalon (from SIALON or silicon-aluminum-oxynitride) though it incorporates a substantial amount of yttria for efficient liquid-phase sintering). The material combines high strength with hot hardness, shock resistance, and other vital properties. Syalon cutting inserts are made by Kennametal and Sandvik and sold as Kyon 2000 and CC680, respectively. The brown Kyon 200 is suitable for machining high-nickel alloys and cast iron, but a later development, Kyon 3000 has good potential for machining cast iron.

Resistance to thermal stress and thermal shock of Kyon 2000 are comparable to those of sintered carbides. Toughness is substantially less than that of carbides, but roughly twice that of oxide-based cutting-tool materials at temperatures up to 850°C. Syon 200 can cut at high edge temperatures and is harder than carbide and some other ceramics at over 700°C, although softer than most at room temperature.

*Whisker-Reinforced Ceramics:* To improve toughness, Greenleaf Corp. has reinforced alumina ceramics with silicon carbide single-crystal "whiskers" that impart a distinctive green color to the material, marketed as WG300. Typically as thin as human hairs, the immensely strong whiskers improve tool life under arduous conditions. Whisker-reinforced ceramics and perhaps hardmetals are likely to become increasingly important as cutting and wear-resistant materials. Their only drawback seems to be the carcinogenic nature of the included fibers, which requires stringent precautions during manufacture.

**Superhard Materials.**—Polycrystalline synthetic diamond (PCD) and cubic boron nitride (PCBN), in the two columns at the right in Table 3, are almost the only cutting-insert materials in the "superhard" category. Both PCD and PCBN are usually made with the highest practicable concentration of the hard constituent, although ceramic or metallic binders can be almost equally important in providing overall strength and optimizing other properties. Variations in grain size are another critical factor in determining cutting characteristics and edge stability. Some manufacturers treat CBN in similar fashion to tungsten carbide, varying the composition and amount of binder within exceptionally wide limits to influence the physical and mechanical properties of the sintered compact.

In comparing these materials, users should note that some inserts comprise solid polycrystalline diamond or CBN and are double-sized to provide twice the number of cutting edges. Others consist of a layer, from 0.020 to 0.040 in. (0.5 to 1 mm) thick, on a tough carbide backing. A third type is produced with a solid superhard material almost surrounded by sintered carbide. A fourth type, used mainly for cutting inserts, comprises solid hard metal with a tiny superhard insert at one or more (usually only one) cutting corners or edges. Superhard cutting inserts are expensive—up to 30 times the cost of equivalent shapes or sizes in ceramic or cemented carbide—but their outstanding properties, exceptional performance and extremely long life can make them by far the most cost-effective for certain applications.

*Diamond:* Diamond is the hardest material found or made. As harder, more abrasive ceramics and other materials came into widespread use, diamond began to be used for

grinding-wheel grits. Cemented carbide tools virtually demanded diamond grinding wheels for fine edge finishing. Solid single-crystal diamond tools were and are used to a small extent for special purposes, such as microtomes, for machining of hard materials, and for exceptionally fine finishes. These diamonds are made from comparatively large, high-quality gem-type diamonds, have isotropic properties, and are very expensive. By comparison, diamond abrasive grits cost only a few dollars a carat.

Synthetic diamonds are produced from graphite using high temperatures and extremely high pressures. The fine diamond particles produced are sintered together in the presence of a metal "catalyst" to produce high-efficiency anisotropic cutting tool inserts. These tools comprise either a solid diamond compact or a layer of sintered diamond on a carbide backing, and are made under conditions similar to, though less severe than, those used in diamond synthesis. Both natural and synthetic diamond can be sintered in this way, although the latter method is the most frequently used.

Polycrystalline diamond (PCD) compacts are immensely hard and can be used to machine many substances, from highly abrasive hardwoods and glass fiber to nonferrous metals, hardmetals, and tough ceramics. Important classes of tools that are also available with cubic boron nitride inserts include brazed-tip drills, single-point turning tools, and face-milling cutters.

*Boron Nitride:* Polycrystalline diamond has one big limitation: it cannot be used to machine steel or any other ferrous material without rapid chemical breakdown. Boron nitride does not have this limitation. Normally soft and slippery like graphite, the soft hexagonal crystals (HBN) become cubic boron nitride (CBN) when subjected to ultrahigh pressures and temperatures, with a structure similar to and hardness second only to diamond. As a solid insert of polycrystalline cubic boron nitride (PCBN), the compound machines even the hardest steel with relative immunity from chemical breakdown or cratering.

Backed by sintered carbide, inserts of PCBN can readily be brazed, increasing the usefulness of the material and the range of tooling in which it can be used. With great hardness and abrasion resistance, coupled with extreme chemical stability when in contact with ferrous alloys at high temperatures, PCBN has the ability to machine both steels and cast irons at high speeds for long operating cycles. Only its currently high cost in relation to hardmetals prevents its wider use in mass-production machining.

Similar in general properties to PCBN, the recently developed "Wurbon" consists of a mixture of ultrafine (0.02  $\mu\text{m}$  grain size) hexagonal and cubic boron nitride with a "wurtzite" structure, and is produced from soft hexagonal boron nitride in a microsecond by an explosive shock-wave.

*Basic Machining Data:* Most mass-production metalcutting operations are carried out with carbide-tipped tools but their correct application is not simple. Even apparently similar batches of the same material vary greatly in their machining characteristics and may require different tool settings to attain optimum performance. Depth of cut, feed, surface speed, cutting rate, desired surface finish, and target tool life often need to be modified to suit the requirements of a particular component.

For the same downtime, the life of an insert between indexings can be less than that of an equivalent brazed tool between regrinds, so a much higher rate of metal removal is possible with the indexable or throwaway insert. It is commonplace for the claims for a new coating to include increases in surface-speed rates of 200–300 per cent, and for a new insert design to offer similar improvements. Many operations are run at metal removal rates that are far from optimum for tool life because the rates used maximize productivity and cost-effectiveness.

Thus any recommendations for cutting speeds and feeds must be oversimplified or extremely complex, and must be hedged with many provisos, dependent on the technical and economic conditions in the manufacturing plant concerned. A preliminary grade

selection should be made from the ISO-based tables and manufacturers' literature consulted for recommendations on the chosen grades and tool designs. If tool life is much greater than that desired under the suggested conditions, speeds, feeds, or depths of cut may be increased. If tools fail by edge breakage, a tougher (more shock-resistant) grade should be selected, with a numerically higher ISO code.

Alternatively, increasing the surface speed and decreasing the feed may be tried. If tools fail prematurely from what appears to be abrasive wear, a harder grade with numerically lower ISO designation should be tried. If cratering is severe, use a grade with higher titanium carbide content; that is, switch from an ISO K to M or M to P grade, use a P grade with lower numerical value, change to a coated grade, or use a coated grade with a (claimed) more-resistant surface layer.

*Built-Up Edge and Cratering:* The big problem in cutting steel with carbide tools is associated with the built-up edge and the familiar phenomenon called cratering. Research has shown that the built-up edge is continuous with the chip itself during normal cutting. Additions of titanium, tantalum, and niobium to the basic carbide mixture have a remarkable effect on the nature and degree of cratering, which is related to adhesion between the tool and the chip.

**Hardmetal Tooling for Wood and Nonmetallics.**—Carbide-tipped circular saws are now conventional for cutting wood, wood products such as chipboard, and plastics, and tipped bandsaws of large size are also gaining in popularity. Tipped handsaws and mechanical equivalents are seldom needed for wood, but they are extremely useful for cutting abrasive building boards, glass-reinforced plastics, and similar material. Like the hardmetal tips used on most other woodworking tools, saw tips generally make use of straight (unalloyed) tungsten carbide/cobalt grades. However, where excessive heat is generated as with the cutting of high-silica hardwoods and particularly abrasive chipboards, the very hard but tough tungsten-titanium-tantalum-niobium carbide solid-solution grades, normally reserved for steel finishing, may be preferred. Saw tips are usually brazed and reground a number of times during service, so coated grades appear to have little immediate potential in this field.

*Cutting Blades and Plane Irons:* These tools comprise long, thin, comparatively wide slabs of carbide on a minimal-thickness steel backing. Compositions are straight tungsten carbide, preferably micrograin (to maintain a keen cutting edge with an included angle of 30° or less), but with relatively high amounts of cobalt, 11–13 per cent, for toughness. Considerable expertise is necessary to braze and grind these cutters without inducing or failing to relieve the excessive stresses that cause distortion or cracking.

*Other Woodworking Cutters:* Routers and other cutters are generally similar to those used on metals and include many indexable-insert designs. The main difference with wood is that rotational and surface speeds can be the maximum available on the machine. High-speed routing of aluminum and magnesium alloys was developed largely from machines and techniques originally designed for work on wood.

*Cutting Other Materials:* The machining of plastics, fiber-reinforced plastics, graphite, asbestos, and other hard and abrasive constructional materials mainly requires abrasion resistance. Cutting pressures and power requirements are generally low. With thermoplastics and some other materials, particular attention must be given to cooling because of softening or degradation of the work material that might be caused by the heat generated in cutting. An important application of cemented carbides is the drilling and routing of printed circuit boards. Solid tungsten carbide drills of extremely small sizes are used for this work.



## FORMING TOOLS

When curved surfaces or those of stepped, angular or irregular shape are required in connection with turning operations, especially on turret lathes and "automatics," forming tools are used. These tools are so made that the contour of the cutting edge corresponds to the shape required and usually they may be ground repeatedly without changing the shape of the cutting edge. There are two general classes of forming tools—the straight type and the circular type. The circular forming tool is generally used on small narrow forms, whereas the straight type is more suitable for wide forming operations. Some straight forming tools are clamped in a horizontal position upon the cut-off slide, whereas the others are held in a vertical position in a special holder. A common form of holder for these vertical tools is one having a dovetail slot in which the forming tool is clamped; hence they are often called "dovetail forming tools." In many cases, two forming tools are used, especially when a very smooth surface is required, one being employed for roughing and the other for finishing.

There was an American standard for forming tool blanks which covered both straight or dovetailed, and circular forms. The formed part of the finished blanks must be shaped to suit whatever job the tool is to be used for. This former standard includes the important dimensions of holders for both straight and circular forms.

**Dimensions of Steps on Straight or Dovetail Forming Tools.**—The diagrams at the top of the accompanying table illustrate a straight or "dovetail" forming tool. The upper or cutting face lies in the same plane as the center of the work and there is no rake. (Many forming tools have rake to increase the cutting efficiency, and this type will be referred to later.) In making a forming tool, the various steps measured perpendicular to the front face (as at  $d$ ) must be proportioned so as to obtain the required radial dimensions on the work. For example, if  $D$  equals the difference between two radial dimensions on the work, then:

$$\text{Step } d = D \times \cos \text{ front clearance angle}$$

**Angles on Straight Forming Tools.**—In making forming tools to the required shape or contour, any angular surfaces (like the steps referred to in the previous paragraph) are affected by the clearance angle. For example, assume that angle  $A$  on the work (see diagram at top of accompanying table) is 20 degrees. The angle on the tool in plane  $x-x$ , in that case, will be slightly less than 20 degrees. In making the tool, this modified or reduced angle is required because of the convenience in machining and measuring the angle square to the front face of the tool or in the plane  $x-x$ .

If the angle on the work is measured from a line parallel to the axis (as at  $A$  in diagram), then the reduced angle on the tool as measured square to the front face (or in plane  $x-x$ ) is found as follows:

$$\tan \text{ reduced angle on tool} = \tan A \times \cos \text{ front clearance angle}$$

If angle  $A$  on the work is larger than, say, 45 degrees, it may be given on the drawing as indicated at  $B$ . In this case, the angle is measured from a plane perpendicular to the axis of the work. When the angle is so specified, the angle on the tool in plane  $x-x$  may be found as follows:

$$\tan \text{ reduced angle on tool} = \frac{\tan B}{\cos \text{ clearance angle}}$$

**Table Giving Step Dimensions and Angles on Straight or Dovetailed Forming Tools.**—The accompanying table *Dimensions of Steps and Angles on Straight Forming Tools* gives the required dimensions and angles within its range, direct or without calculation.

Dimensions of Steps and Angles on Straight Forming Tools

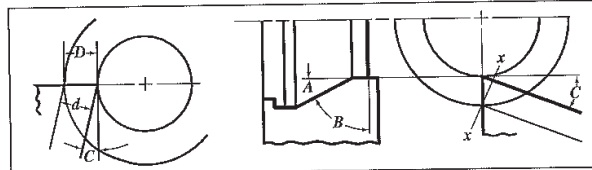

Upper section of table gives depth  $d$  of step on forming tool for a given dimension  $D$  that equals the actual depth of the step on the work, measured radially and along the cutting face of the tool (see diagram at left). First, locate depth  $D$  required on work; then find depth  $d$  on tool under tool clearance angle  $C$ . Depth  $d$  is measured perpendicular to front face of tool.

Radial Depth of Step $D$	Depth $d$ of step on tool			Radial Depth of Step $D$	Depth $d$ of step on tool		
	When $C = 10^\circ$	When $C = 15^\circ$	When $C = 20^\circ$		When $C = 10^\circ$	When $C = 15^\circ$	When $C = 20^\circ$
0.001	0.00098	0.00096	0.00094	0.040	0.03939	0.03863	0.03758
0.002	0.00197	0.00193	0.00187	0.050	0.04924	0.04829	0.04698
0.003	0.00295	0.00289	0.00281	0.060	0.05908	0.05795	0.05638
0.004	0.00393	0.00386	0.00375	0.070	0.06893	0.06761	0.06577
0.005	0.00492	0.00483	0.00469	0.080	0.07878	0.07727	0.07517
0.006	0.00590	0.00579	0.00563	0.090	0.08863	0.08693	0.08457
0.007	0.00689	0.00676	0.00657	0.100	0.09848	0.09659	0.09396
0.008	0.00787	0.00772	0.00751	0.200	0.19696	0.19318	0.18793
0.009	0.00886	0.00869	0.00845	0.300	0.29544	0.28977	0.28190
0.010	0.00984	0.00965	0.00939	0.400	0.39392	0.38637	0.37587
0.020	0.01969	0.01931	0.01879	0.500	0.49240	0.48296	0.46984
0.030	0.02954	0.02897	0.02819	...	...	...	...

Section of table below gives angles as measured in plane  $x-x$  perpendicular to front face of forming tool (see diagram on right). Find in first column the angle  $A$  required on work; then find reduced angle in plane  $x-x$  under given clearance angle  $C$ .

Angle $A$ in Plane of Tool Cutting Face	Angle on tool in plane $x-x$			Angle $A$ in Plane of Tool Cutting Face	Angle on tool in plane $x-x$		
	When $C = 10^\circ$	When $C = 15^\circ$	When $C = 20^\circ$		When $C = 10^\circ$	When $C = 15^\circ$	When $C = 20^\circ$
5°	4° 55'	4° 50'	4° 42'	50°	49° 34'	49° 1'	48° 14'
10	9 51	9 40	9 24	55	54 35	54 4	53 18
15	14 47	14 31	14 8	60	59 37	59 8	58 26
20	19 43	19 22	18 53	65	64 40	64 14	63 36
25	24 40	24 15	23 40	70	69 43	69 21	68 50
30	29 37	29 9	28 29	75	74 47	74 30	74 5
35	34 35	34 4	33 20	80	79 51	79 39	79 22
40	39 34	39 1	38 15	85	84 55	84 49	84 41
45	44 34	44 0	43 13	...	...	...	...

*To Find Dimensions of Steps:* The upper section of the table is used in determining the dimensions of steps. The radial depth of the step or the actual cutting depth  $D$  (see left-hand diagram) is given in the first column of the table. The columns that follow give the corresponding depths  $d$  for a front clearance angle of 10, 15, or 20 degrees. To illustrate the use of the table, suppose a tool is required for turning the part shown in Fig. 1, which has diameters of 0.75, 1.25, and 1.75 inches, respectively. The difference between the largest and the smallest radius is 0.5 inch, which is the depth of one step. Assume that the clearance angle is 15 degrees. First, locate 0.5 in the column headed "Radial Depth of Step  $D$ "; then find depth  $d$  in the column headed "when  $C = 15^\circ$ ." As will be seen, this depth is 0.48296 inch. Practically the same procedure is followed in determining the depth of the second step on the tool. The difference in the radii in this case equals 0.25. This value is not given directly in the table, so first find the depth equivalent to 0.200 and add to it the depth equivalent to 0.050. Thus, we have  $0.19318 + 0.04829 = 0.24147$ . In using this table, it is assumed that the top face of the tool is set at the height of the work axis.

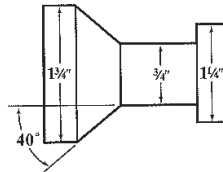

Fig. 1.

*To Find Angle:* The lower section of the table applies to angles when they are measured relative to the axis of the work. The application of the table will again be illustrated by using the part shown in Fig. 1. The angle used here is 40 degrees (which is also the angle in the plane of the cutting face of the tool). If the clearance angle is 15 degrees, the angle measured in plane  $x-x$  square to the face of the tool is shown by the table to be  $39^\circ 1'$ —a reduction of practically 1 degree.

If a straight forming tool has rake, the depth  $x$  of each step (see Fig. 2), measured perpendicular to the front or clearance face, is affected not only by the clearance angle, but by the rake angle  $F$  and the radii  $R$  and  $r$  of the steps on the work. First, it is necessary to find three angles, designated  $A$ ,  $B$ , and  $C$ , that are not shown on the drawing.

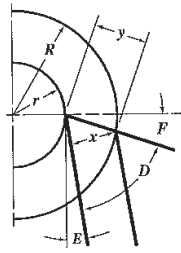

Fig. 2.

Angle  $A = 180^\circ - \text{rake angle } F$

$$\sin B = \frac{r \sin A}{R}$$

Angle  $C = 180^\circ - (A + B)$

$$y = \frac{R \sin C}{\sin A}$$

Angle  $D$  of tool =  $90^\circ - (E + F)$

Depth  $x = y \sin D$

If the work has two or more shoulders, the depth  $x$  for other steps on the tool may be determined for each radius  $r$ . If the work has curved or angular forms, it is more practical to use a tool without rake because its profile, in the plane of the cutting face, duplicates that of the work.

*Example:* Assume that radius  $R$  equals 0.625 inch and radius  $r$  equals 0.375 inch, so that the step on the work has a radial depth of 0.25 inch. The tool has a rake angle  $F$  of 10 degrees and a clearance angle  $E$  of 15 degrees. Then angle  $A = 180 - 10 = 170$  degrees.

$$\sin B = \frac{0.375 \times 0.17365}{0.625} = 0.10419$$

Angle  $B = 5^\circ 59'$  nearly.      Angle  $C = 180 - (170^\circ + 5^\circ 59') = 4^\circ 1'$

$$\text{Dimension } y = \frac{0.625 \times 0.07005}{0.17365} = 0.25212$$

Angle  $D = 90^\circ - (15 + 10) = 65$  degrees

Depth  $x$  of step =  $0.25212 \times 0.90631 = 0.2285$  inch

**Circular Forming Tools.**—To provide sufficient peripheral clearance on circular forming tools, the cutting face is offset with relation to the center of the tool a distance  $C$ , as shown in Fig. 3. Whenever a circular tool has two or more diameters, the difference in the radii of the steps on the tool will not correspond exactly to the difference in the steps on the work. The form produced with the tool also changes, although the change is very slight, unless the amount of offset  $C$  is considerable. Assume that a circular tool is required to produce the piece  $A$  having two diameters as shown.

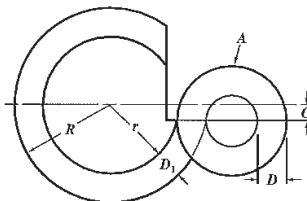

Fig. 3.

If the difference  $D_1$  between the large and small radii of the tool were made equal to dimension  $D$  required on the work,  $D$  would be a certain amount oversize, depending upon the offset  $C$  of the cutting edge. The following formulas can be used to determine the radii of circular forming tools for turning parts to different diameters:

Let  $R$  = largest radius of tool in inches;  $D$  = difference in radii of steps on work;  $C$  = amount cutting edge is offset from center of tool;  $r$  = required radius in inches; then

$$r = \sqrt{(\sqrt{R^2 - C^2} - D)^2 + C^2} \quad (1)$$

If the small radius  $r$  is given and the large radius  $R$  is required, then

$$R = \sqrt{(\sqrt{r^2 - C^2} + D)^2 + C^2} \quad (2)$$

To illustrate, if  $D$  (Fig. 3) is to be  $\frac{1}{8}$  inch, the large radius  $R$  is  $1\frac{1}{8}$  inches, and  $C$  is  $\frac{5}{32}$  inch, what radius  $r$  would be required to compensate for the offset  $C$  of the cutting edge? Inserting these values in Formula (1):

$$r = \sqrt{(\sqrt{(1\frac{1}{8})^2 - (\frac{5}{32})^2} - (\frac{1}{8})^2 + (\frac{5}{32})^2)^2} = 1.0014 \text{ inches}$$

The value of  $r$  is thus found to be 1.0014 inches; hence, the diameter =  $2 \times 1.0014 = 2.0028$  inches instead of 2 inches, as it would have been if the cutting edge had been exactly on the center line. Formulas for circular tools used on different makes of screw machines can be simplified when the values  $R$  and  $C$  are constant for each size of machine. The accompanying table, "Formulas for Circular Forming Tools," gives the standard values of  $R$  and  $C$  for circular tools used on different automatics. The formulas for determining the radius  $r$  (see column at right-hand side of table) contain a constant that represents the value of the expression  $\sqrt{R^2 - C^2}$  in Formula (1).

The table "Constants for Determining Diameters of Circular Forming Tools" has been compiled to facilitate proportioning tools of this type and gives constants for computing the various diameters of forming tools, when the cutting face of the tool is  $\frac{1}{8}$ ,  $\frac{3}{16}$ ,  $\frac{1}{4}$ , or  $\frac{5}{16}$  inch below the horizontal center line. As there is no standard distance for the location of the cutting face, the table has been prepared to correspond with distances commonly used. As an example, suppose the tool is required for a part having three diameters of 1.75, 0.75, and 1.25 inches, respectively, as shown in Fig. 1, and that the largest diameter of the tool is 3 inches and the cutting face is  $\frac{1}{4}$  inch below the horizontal center line. The first step would be to determine approximately the respective diameters of the forming tool and then correct the diameters by the use of the table. To produce the three diameters shown in Fig. 1, with a 3-inch forming tool, the tool diameters would be approximately 2, 3, and 2.5 inches, respectively. The first dimension (2 inches) is 1 inch less in diameter than that of the tool, and the necessary correction should be given in the column "Correction for Difference in Diameter"; but as the table is only extended to half-inch differences, it will be necessary to obtain this particular correction in two steps. On the line for 3-inch diameter and under corrections for  $\frac{1}{2}$  inch, we find 0.0085; then in line with  $2\frac{1}{2}$  and under the same heading, we find 0.0129, hence the total correction would be  $0.0085 + 0.0129 = 0.0214$  inch. This correction is added to the approximate diameter, making the exact diameter of the first step  $2 + 0.0214 = 2.0214$  inches. The next step would be computed in the same way, by noting on the 3-inch line the correction for  $\frac{1}{2}$  inch and adding it to the approximate diameter of the second step, giving an exact diameter of  $2.5 + 0.0085 + 2.5085$  inches. Therefore, to produce the part shown in Fig. 1, the tool should have three steps of 3, 2.0214, and 2.5085 inches, respectively, provided the cutting face is  $\frac{1}{4}$  inch below the center. All diameters are computed in this way, from the largest diameter of the tool.

Formulas for Circular Forming Tools (For notation, see Fig. 3)

Make of Machine	Size of Machine	Radius $R$ , Inches	Offset $C$ , Inches	Radius $r$ , Inches
Brown & Sharpe	No. 00	0.875	0.125	$r = \sqrt{(0.8660 - D)^2 + 0.0156}$
	No. 0	1.125	0.15625	$r = \sqrt{(1.1141 - D)^2 + 0.0244}$
	No. 2	1.50	0.250	$r = \sqrt{(1.4790 - D)^2 + 0.0625}$
	No. 6	2.00	0.3125	$r = \sqrt{(1.975 - D)^2 + 0.0976}$
Acme	No. 51	0.75	0.09375	$r = \sqrt{(1.7441 - D)^2 + 0.0088}$
	No. 515	0.75	0.09375	$r = \sqrt{(0.7441 - D)^2 + 0.0088}$
	No. 52	1.0	0.09375	$r = \sqrt{(0.9956 - D)^2 + 0.0088}$
	No. 53	1.1875	0.125	$r = \sqrt{(1.1809 - D)^2 + 0.0156}$
	No. 54	1.250	0.15625	$r = \sqrt{(1.2402 - D)^2 + 0.0244}$
	No. 55	1.250	0.15625	$r = \sqrt{(1.2402 - D)^2 + 0.0244}$
	No. 56	1.50	0.1875	$r = \sqrt{(1.4882 - D)^2 + 0.0352}$
Cleveland	$\frac{1}{4}"$	0.625	0.03125	$r = \sqrt{(0.6242 - D)^2 + 0.0010}$
	$\frac{3}{8}"$	0.084375	0.0625	$r = \sqrt{(0.8414 - D)^2 + 0.0039}$
	$\frac{1}{2}"$	1.15625	0.0625	$r = \sqrt{(1.1546 - D)^2 + 0.0039}$
	$\frac{3}{4}"$	1.1875	0.0625	$r = \sqrt{(1.1859 - D)^2 + 0.0039}$
	$1\frac{1}{4}"$	1.375	0.0625	$r = \sqrt{(1.3736 - D)^2 + 0.0039}$
	2"	1.375	0.0625	$r = \sqrt{(1.3736 - D)^2 + 0.0039}$
	$2\frac{1}{4}"$	1.625	0.125	$r = \sqrt{(1.6202 - D)^2 + 0.0156}$
	$2\frac{1}{2}"$	1.875	0.15625	$r = \sqrt{(1.8685 - D)^2 + 0.0244}$
	$3\frac{1}{2}"$	1.875	0.15625	$r = \sqrt{(1.8685 - D)^2 + 0.0244}$
	$4\frac{1}{4}"$	2.50	0.250	$r = \sqrt{(2.4875 - D)^2 + 0.0625}$
6"	2.625	0.250	$r = \sqrt{(2.6131 - D)^2 + 0.0625}$	

The tables "Corrected Diameters of Circular Forming Tools" are especially applicable to tools used on Brown & Sharpe automatic screw machines. Directions for using these tables are given at the end of Table 4.

**Circular Tools Having Top Rake.**—Circular forming tools without top rake are satisfactory for brass, but tools for steel or other tough metals cut better when there is a rake angle of 10 or 12 degrees. For such tools, the small radius  $r$  (see Fig. 3) for an outside radius  $R$  may be found by the formula

$$r = \sqrt{P^2 + R^2 - 2PR \cos \theta}$$

To find the value of  $P$ , proceed as follows:  $\sin \phi = \text{small radius on work} \times \sin \text{rake angle} + \text{large radius on work}$ . Angle  $\beta = \text{rake angle} - \phi$ .  $P = \text{large radius on work} \times \sin \beta + \text{sin rake angle}$ . Angle  $\theta = \text{rake angle} + \delta$ .  $\text{Sin } \delta = \text{vertical height } C \text{ from center of tool to center of work} + R$ . It is assumed that the tool point is to be set at the same height as the work center.

Dimensions for Circular Cut-Off Tools

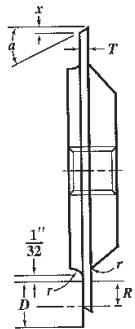

Dia. of Stock	Soft Brass, Copper		Norway Iron, Machine Steel		Drill Rod, Tool Steel	
	$a = 23 \text{ Deg.}$		$a = 15 \text{ Deg.}$		$a = 12 \text{ Deg.}$	
	$T$	$x$	$T$	$x$	$T$	$x$
$\frac{1}{16}$	0.031	0.013	0.039	0.010	0.043	0.009
$\frac{1}{8}$	0.044	0.019	0.055	0.015	0.062	0.013
$\frac{3}{16}$	0.052	0.022	0.068	0.018	0.076	0.016
$\frac{1}{4}$	0.062	0.026	0.078	0.021	0.088	0.019
$\frac{5}{16}$	0.069	0.029	0.087	0.023	0.098	0.021
$\frac{3}{8}$	0.076	0.032	0.095	0.025	0.107	0.023
$\frac{7}{16}$	0.082	0.035	0.103	0.028	0.116	0.025
$\frac{1}{2}$	0.088	0.037	0.110	0.029	0.124	0.026
$\frac{9}{16}$	0.093	0.039	0.117	0.031	0.131	0.028
$\frac{5}{8}$	0.098	0.042	0.123	0.033	0.137	0.029
$\frac{11}{16}$	0.103	0.044	0.129	0.035	0.145	0.031
$\frac{3}{4}$	0.107	0.045	0.134	0.036	0.152	0.032
$\frac{13}{16}$	0.112	0.047	0.141	0.038	0.158	0.033
$\frac{7}{8}$	0.116	0.049	0.146	0.039	0.164	0.035
$\frac{15}{16}$	0.120	0.051	0.151	0.040	0.170	0.036
1	0.124	0.053	0.156	0.042	0.175	0.037

The length of the blade equals radius of stock  $R + x + r + \frac{1}{32}$  inch (for notation, see illustration above);  $r = \frac{1}{16}$  inch for  $\frac{3}{8}$  to  $\frac{1}{4}$ -inch stock, and  $\frac{3}{32}$  inch for  $\frac{1}{4}$ - to 1-inch stock.

Constant for Determining Diameters of Circular Forming Tools

Dia. of Tool	Radius of Tool	Cutting Face $\frac{1}{8}$ inch Below Center		Cutting Face $\frac{1}{4}$ inch Below Center		Cutting Face $\frac{3}{8}$ inch Below Center		Cutting Face $\frac{1}{2}$ inch Below Center	
		$\frac{1}{8}$ inch	$\frac{1}{4}$ inch	$\frac{1}{8}$ inch	$\frac{1}{4}$ inch	$\frac{1}{8}$ inch	$\frac{1}{4}$ inch	$\frac{1}{8}$ inch	$\frac{1}{4}$ inch
1	0.500	...	...	...	...	...	...	...	...
1 $\frac{1}{4}$	0.5625	0.0036	0.0086	0.0167	0.0396	0.0729	0.1296	0.2025	0.2916
1 $\frac{1}{2}$	0.625	0.0028	0.0067	0.0128	0.0296	0.0519	0.0916	0.1385	0.2025
1 $\frac{3}{4}$	0.6875	0.0023	0.0054	0.0102	0.0231	0.0417	0.0684	0.1029	0.1521
1 $\frac{1}{2}$	0.750	0.0019	0.0045	0.0083	0.0185	0.0341	0.0549	0.0829	0.1225
1 $\frac{3}{4}$	0.8125	0.0016	0.0037	0.0069	0.0158	0.0297	0.0468	0.0709	0.1044
1 $\frac{1}{2}$	0.875	0.0014	0.0032	0.0069	0.0158	0.0297	0.0468	0.0709	0.1044
1 $\frac{3}{4}$	0.9375	0.0012	0.0027	0.0050	0.0114	0.0216	0.0341	0.0504	0.0729
2	1.000	0.0010	0.0022	0.0044	0.0094	0.0176	0.0284	0.0432	0.0625
2 $\frac{1}{4}$	1.0625	0.0009	0.0021	0.0038	0.0083	0.0161	0.0261	0.0396	0.0561
2 $\frac{1}{2}$	1.125	0.0008	0.0018	0.0034	0.0072	0.0146	0.0246	0.0376	0.0529
2 $\frac{3}{4}$	1.1875	0.0007	0.0016	0.0029	0.0064	0.0131	0.0224	0.0349	0.0496
2 $\frac{1}{2}$	1.250	0.0006	0.0014	0.0027	0.0057	0.0119	0.0216	0.0329	0.0461
2 $\frac{3}{4}$	1.3125	0.0006	0.0013	0.0024	0.0052	0.0108	0.0196	0.0296	0.0421
2 $\frac{1}{2}$	1.375	0.0005	0.0011	0.0022	0.0046	0.0094	0.0176	0.0261	0.0376
2 $\frac{3}{4}$	1.4375	0.0005	0.0011	0.0020	0.0046	0.0083	0.0161	0.0246	0.0349
3	1.500	0.0004	0.0009	0.0018	0.0038	0.0072	0.0146	0.0224	0.0329
3 $\frac{1}{4}$	1.5625	0.0004	0.0009	0.0017	0.0038	0.0072	0.0146	0.0224	0.0329
3 $\frac{1}{2}$	1.625	0.0003	0.0008	0.0015	0.0032	0.0064	0.0131	0.0216	0.0309
3 $\frac{3}{4}$	1.6875	0.0003	0.0008	0.0014	0.0032	0.0064	0.0131	0.0216	0.0309
3 $\frac{1}{2}$	1.750	0.0003	0.0007	0.0013	0.0028	0.0057	0.0119	0.0216	0.0296
3 $\frac{3}{4}$	1.8125	0.0003	0.0007	0.0012	0.0028	0.0057	0.0119	0.0216	0.0296
3 $\frac{1}{2}$	1.875	0.0002	0.0006	0.0011	0.0024	0.0052	0.0108	0.0204	0.0284



Corrected Diameters of Circular Forming Tools—1

Length <i>c</i> on Tool	Number of B. & S. Automatic Screw Machine			Length <i>c</i> on Tool	Number of B. & S. Automatic Screw Machine		
	No. 00	No. 0	No. 2		No. 00	No. 0	No. 2
0.001	1.7480	2.2480	2.9980	0.058	1.6353	2.1352	2.8857
0.002	1.7460	2.2460	2.9961	0.059	1.6333	2.1332	2.8837
0.003	1.7441	2.2441	2.9941	0.060	1.6313	2.1312	2.8818
0.004	1.7421	2.2421	2.9921	0.061	1.6294	2.1293	2.8798
0.005	1.7401	2.2401	2.9901	0.062	1.6274	2.1273	2.8778
0.006	1.7381	2.2381	2.9882	$\frac{1}{16}$	1.6254	2.1253	2.8758
0.007	1.7362	2.2361	2.9862	0.063	1.6234	2.1233	2.8739
0.008	1.7342	2.2341	2.9842	0.064	1.6214	2.1213	2.8719
0.009	1.7322	2.2321	2.9823	0.065	1.6195	2.1194	2.8699
0.010	1.7302	2.2302	2.9803	0.066	1.6175	2.1174	2.8680
0.011	1.7282	2.2282	2.9783	0.067	1.6155	2.1154	2.8660
0.012	1.7263	2.2262	2.9763	0.068	1.6136	2.1134	2.8640
0.013	1.7243	2.2243	2.9744	0.069	1.6116	2.1115	2.8621
0.014	1.7223	2.2223	2.9724	0.070	1.6096	2.1095	2.8601
0.015	1.7203	2.2203	2.9704	0.071	1.6076	2.1075	2.8581
$\frac{1}{16}$	1.7191	2.2191	2.9692	0.072	1.6057	2.1055	2.8561
0.016	1.7184	2.2183	2.9685	0.073	1.6037	2.1035	2.8542
0.017	1.7164	2.2163	2.9665	0.074	1.6017	2.1016	2.8522
0.018	1.7144	2.2143	2.9645	0.075	1.5997	2.0996	2.8503
0.019	1.7124	2.2123	2.9625	0.076	1.5978	2.0976	2.8483
0.020	1.7104	2.2104	2.9606	0.077	1.5958	2.0956	2.8463
0.021	1.7085	2.2084	2.9586	0.078	1.5938	2.0936	2.8443
0.022	1.7065	2.2064	2.9566	$\frac{3}{16}$	1.5918	2.0917	2.8424
0.023	1.7045	2.2045	2.9547	0.079	1.5898	2.0897	2.8404
0.024	1.7025	2.2025	2.9527	0.080	1.5879	2.0877	2.8384
0.025	1.7005	2.2005	2.9507	0.081	1.5859	2.0857	2.8365
0.026	1.6986	2.1985	2.9488	0.082	1.5839	2.0838	2.8345
0.027	1.6966	2.1965	2.9468	0.083	1.5820	2.0818	2.8325
0.028	1.6946	2.1945	2.9448	0.084	1.5800	2.0798	2.8306
0.029	1.6926	2.1925	2.9428	0.085	1.5780	2.0778	2.8286
0.030	1.6907	2.1906	2.9409	0.086	1.5760	2.0759	2.8266
0.031	1.6887	2.1886	2.9389	0.087	1.5740	2.0739	2.8247
$\frac{1}{8}$	1.6882	2.1881	2.9384	0.088	1.5721	2.0719	2.8227
0.032	1.6867	2.1866	2.9369	0.089	1.5701	2.0699	2.8207
0.033	1.6847	2.1847	2.9350	0.090	1.5681	2.0679	2.8187
0.034	1.6827	2.1827	2.9330	0.091	1.5661	2.0660	2.8168
0.035	1.6808	2.1807	2.9310	0.092	1.5641	2.0640	2.8148
0.036	1.6788	2.1787	2.9290	0.093	1.5621	2.0620	2.8128
0.037	1.6768	2.1767	2.9271	$\frac{1}{4}$	1.5602	2.0600	2.8109
0.038	1.6748	2.1747	2.9251	0.094	1.5582	2.0581	2.8089
0.039	1.6729	2.1727	2.9231	0.095	1.5563	2.0561	2.8069
0.040	1.6709	2.1708	2.9211	0.096	1.5543	2.0541	2.8050
0.041	1.6689	2.1688	2.9192	0.097	1.5523	2.0521	2.8030
0.042	1.6669	2.1668	2.9172	0.098	1.5503	2.0502	2.8010
0.043	1.6649	2.1649	2.9152	0.099	1.5484	2.0482	2.7991
0.044	1.6630	2.1629	2.9133	0.100	1.5464	2.0462	2.7971
0.045	1.6610	2.1609	2.9113	0.101	1.5444	2.0442	2.7951
0.046	1.6590	2.1589	2.9093	0.102	1.5425	2.0422	2.7932
$\frac{3}{16}$	1.6573	2.1572	2.9076	0.103	1.5405	2.0403	2.7912
0.047	1.6570	2.1569	2.9073	0.104	1.5385	2.0383	2.7892
0.048	1.6550	2.1549	2.9054	0.105	1.5365	2.0363	2.7873
0.049	1.6531	2.1529	2.9034	0.106	1.5346	2.0343	2.7853
0.050	1.6511	2.1510	2.9014	0.107	1.5326	2.0323	2.7833
0.051	1.6491	2.1490	2.8995	0.108	1.5306	2.0304	2.7814
0.052	1.6471	2.1470	2.8975	0.109	1.5287	2.0284	2.7794
0.053	1.6452	2.1451	2.8955	$\frac{1}{2}$	1.5267	2.0264	2.7774
0.054	1.6432	2.1431	2.8936	0.110			
0.055	1.6412	2.1411	2.8916	0.111			
0.056	1.6392	2.1391	2.8896	0.112			
0.057	1.6373	2.1372	2.8877	0.113			

Corrected Diameters of Circular Forming Tools—1 (Continued)

Length of Tool	Number of B. & S. Automatic Screw Machine			Length of Tool	Number of B. & S. Automatic Screw Machine		
	No. 00	No. 0	No. 2		No. 00	No. 0	No. 2
0.113	1.5267	2.0264	2.7774	0.171	1.4124	1.9119	2.6634
0.114	1.5247	2.0245	2.7755	$\frac{1}{16}$	1.4107	1.9103	2.6617
0.115	1.5227	2.0225	2.7735	0.172	1.4104	1.9099	2.6614
0.116	1.5208	2.0205	2.7715	0.173	1.4084	1.9080	2.6595
0.117	1.5188	2.0185	2.7696	0.174	1.4065	1.9060	2.6575
0.118	1.5168	2.0165	2.7676	0.175	1.4045	1.9040	2.6556
0.119	1.5148	2.0146	2.7656	0.176	1.4025	1.9021	2.6536
0.120	1.5129	2.0126	2.7637	0.177	1.4006	1.9001	2.6516
0.121	1.5109	2.0106	2.7617	0.178	1.3986	1.8981	2.6497
0.122	1.5089	2.0087	2.7597	0.179	1.3966	1.8961	2.6477
0.123	1.5070	2.0067	2.7578	0.180	1.3947	1.8942	2.6457
0.124	1.5050	2.0047	2.7558	0.181	1.3927	1.8922	2.6438
0.125	1.5030	2.0027	2.7538	0.182	1.3907	1.8902	2.6418
0.126	1.5010	2.0008	2.7519	0.183	1.3888	1.8882	2.6398
0.127	1.4991	1.9988	2.7499	0.184	1.3868	1.8863	2.6379
0.128	1.4971	1.9968	2.7479	0.185	1.3848	1.8843	2.6359
0.129	1.4951	1.9948	2.7460	0.186	1.3829	1.8823	2.6339
0.130	1.4932	1.9929	2.7440	0.187	1.3809	1.8804	2.6320
0.131	1.4912	1.9909	2.7420	$\frac{3}{16}$	1.3789	1.8784	2.6300
0.132	1.4892	1.9889	2.7401	0.188	1.3789	1.8784	2.6300
0.133	1.4872	1.9869	2.7381	0.189	1.3770	1.8764	2.6281
0.134	1.4853	1.9850	2.7361	0.190	1.3750	1.8744	2.6261
0.135	1.4833	1.9830	2.7342	0.191	1.3730	1.8725	2.6241
0.136	1.4813	1.9810	2.7322	0.192	1.3711	1.8705	2.6222
0.137	1.4794	1.9790	2.7302	0.193	1.3691	1.8685	2.6202
0.138	1.4774	1.9771	2.7282	0.194	1.3671	1.8665	2.6182
0.139	1.4754	1.9751	2.7263	0.195	1.3652	1.8646	2.6163
0.140	1.4734	1.9731	2.7243	0.196	1.3632	1.8626	2.6143
$\frac{1}{4}$	1.4722	1.9719	2.7231	0.197	1.3612	1.8606	2.6123
0.141	1.4715	1.9711	2.7224	0.198	1.3592	1.8587	2.6104
0.142	1.4695	1.9692	2.7204	0.199	1.3573	1.8567	2.6084
0.143	1.4675	1.9672	2.7184	0.200	1.3553	1.8547	2.6064
0.144	1.4655	1.9652	2.7165	0.201	...	1.8527	2.6045
0.145	1.4636	1.9632	2.7145	0.202	...	1.8508	2.6025
0.146	1.4616	1.9613	2.7125	0.203	...	1.8488	2.6006
0.147	1.4596	1.9593	2.7106	$\frac{1}{4}$	...	1.8468	2.6003
0.148	1.4577	1.9573	2.7086	0.204	...	1.8468	2.5986
0.149	1.4557	1.9553	2.7066	0.205	...	1.8449	2.5966
0.150	1.4537	1.9534	2.7047	0.206	...	1.8429	2.5947
0.151	1.4517	1.9514	2.7027	0.207	...	1.8409	2.5927
0.152	1.4498	1.9494	2.7007	0.208	...	1.8390	2.5908
0.153	1.4478	1.9474	2.6988	0.209	...	1.8370	2.5888
0.154	1.4458	1.9455	2.6968	0.210	...	1.8350	2.5868
0.155	1.4439	1.9435	2.6948	0.211	...	1.8330	2.5849
0.156	1.4419	1.9415	2.6929	0.212	...	1.8311	2.5829
$\frac{3}{8}$	1.4414	1.9410	2.6924	0.213	...	1.8291	2.5809
0.157	1.4399	1.9395	2.6909	0.214	...	1.8271	2.5790
0.158	1.4380	1.9376	2.6889	0.215	...	1.8252	2.5770
0.159	1.4360	1.9356	2.6870	0.216	...	1.8232	2.5751
0.160	1.4340	1.9336	2.6850	0.217	...	1.8212	2.5731
0.161	1.4321	1.9317	2.6830	0.218	...	1.8193	2.5711
0.162	1.4301	1.9297	2.6811	$\frac{1}{2}$	...	1.8178	2.5697
0.163	1.4281	1.9277	2.6791	0.219	...	1.8173	2.5692
0.164	1.4262	1.9257	2.6772	0.220	...	1.8153	2.5672
0.165	1.4242	1.9238	2.6752	0.221	...	1.8133	2.5653
0.166	1.4222	1.9218	2.6732	0.222	...	1.8114	2.5633
0.167	1.4203	1.9198	2.6713	0.223	...	1.8094	2.5613
0.168	1.4183	1.9178	2.6693	0.224	...	1.8074	2.5594
0.169	1.4163	1.9159	2.6673	0.225	...	1.8055	2.5574
0.170	1.4144	1.9139	2.6654	0.226	...	1.8035	2.5555

Corrected Diameters of Circular Forming Tools—2

Length e on Tool	Number of B. & S. Screw Machine		Length e on Tool	Number of B. & S. Screw Machine		Length e on Tool	Number 2 B. & S. Machine
	No. 0	No. 2		No. 0	No. 2		
0.227	1.8015	2.5575	0.284	1.6894	2.4418	0.341	2.3203
0.228	1.7996	2.5515	0.285	1.6874	2.4398	0.342	2.3284
0.229	1.7976	2.5496	0.286	1.6854	2.4378	0.343	2.3264
0.230	1.7956	2.5476	0.287	1.6835	2.4359	$\frac{1}{16}$	2.3250
0.231	1.7936	2.5456	0.288	1.6815	2.4340	0.344	2.3245
0.232	1.7917	2.5437	0.289	1.6795	2.4320	0.345	2.3225
0.233	1.7897	2.5417	0.290	1.6776	2.4300	0.346	2.3206
0.234	1.7877	2.5398	0.291	1.6756	2.4281	0.347	2.3186
$\frac{1}{4}$	1.7870	2.5390	0.292	1.6736	2.4261	0.348	2.3166
0.235	1.7858	2.5378	0.293	1.6717	2.4242	0.349	2.3147
0.236	1.7838	2.5358	0.294	1.6697	2.4222	0.350	2.3127
0.237	1.7818	2.5339	0.295	1.6677	2.4203	0.351	2.3108
0.238	1.7799	2.5319	0.296	1.6658	2.4183	0.352	2.3088
0.239	1.7779	2.5300	$\frac{3}{16}$	1.6641	2.4166	0.353	2.3069
0.240	1.7759	2.5280	0.297	1.6638	2.4163	0.354	2.3049
0.241	1.7739	2.5260	0.298	1.6618	2.4144	0.355	2.3030
0.242	1.7720	2.5241	0.299	1.6599	2.4124	0.356	2.3010
0.243	1.7700	2.5221	0.300	1.6579	2.4105	0.357	2.2991
0.244	1.7680	2.5201	0.301	...	2.4085	0.358	2.2971
0.245	1.7661	2.5182	0.302	...	2.4066	0.359	2.2952
0.246	1.7641	2.5162	0.303	...	2.4046	$\frac{7}{16}$	2.2945
0.247	1.7621	2.5143	0.304	...	2.4026	0.360	2.2932
0.248	1.7602	2.5123	0.305	...	2.4007	0.361	2.2919
0.249	1.7582	2.5104	0.306	...	2.3987	0.362	2.2893
0.250	1.7562	2.5084	0.307	...	2.3968	0.363	2.2874
0.251	1.7543	2.5064	0.308	...	2.3948	0.364	2.2854
0.252	1.7523	2.5045	0.309	...	2.3929	0.365	2.2835
0.253	1.7503	2.5025	0.310	...	2.3909	0.366	2.2815
0.254	1.7484	2.5005	0.311	...	2.3890	0.367	2.2796
0.255	1.7464	2.4986	0.312	...	2.3870	0.368	2.2776
0.256	1.7444	2.4966	$\frac{5}{16}$	...	2.3860	0.369	2.2757
0.257	1.7425	2.4947	0.313	...	2.3851	0.370	2.2737
0.258	1.7405	2.4927	0.314	...	2.3831	0.371	2.2718
0.259	1.7385	2.4908	0.315	...	2.3811	0.372	2.2698
0.260	1.7366	2.4888	0.316	...	2.3792	0.373	2.2679
0.261	1.7346	2.4868	0.317	...	2.3772	0.374	2.2659
0.262	1.7326	2.4849	0.318	...	2.3753	0.375	2.2640
0.263	1.7306	2.4829	0.319	...	2.3733	0.376	2.2620
0.264	1.7287	2.4810	0.320	...	2.3714	0.377	2.2601
0.265	1.7267	2.4790	0.321	...	2.3694	0.378	2.2581
$\frac{1}{4}$	1.7255	2.4778	0.322	...	2.3675	0.379	2.2562
0.266	1.7248	2.4770	0.323	...	2.3655	0.380	2.2542
0.267	1.7228	2.4751	0.324	...	2.3636	0.381	2.2523
0.268	1.7208	2.4731	0.325	...	2.3616	0.382	2.2503
0.269	1.7189	2.4712	0.326	...	2.3596	0.383	2.2484
0.270	1.7169	2.4692	0.327	...	2.3577	0.384	2.2464
0.271	1.7149	2.4673	0.328	...	2.3557	0.385	2.2445
0.272	1.7130	2.4653	$\frac{3}{4}$	...	2.3535	0.386	2.2425
0.273	1.7110	2.4633	0.329	...	2.3538	0.387	2.2406
0.274	1.7090	2.4614	0.330	...	2.3518	0.388	2.2386
0.275	1.7071	2.4594	0.331	...	2.3499	0.389	2.2367
0.276	1.7051	2.4575	0.332	...	2.3479	0.390	2.2347
0.277	1.7031	2.4555	0.333	...	2.3460	$\frac{1}{2}$	2.2335
0.278	1.7012	2.4535	0.334	...	2.3440	0.391	2.2328
0.279	1.6992	2.4516	0.335	...	2.3421	0.392	2.2308
0.280	1.6972	2.4496	0.336	...	2.3401	0.393	2.2289
0.281	1.6953	2.4477	0.337	...	2.3381	0.394	2.2269
$\frac{1}{4}$	1.6948	2.4472	0.338	...	2.3362	0.395	2.2250
0.282	1.6933	2.4457	0.339	...	2.3342	0.396	2.2230
0.283	1.6913	2.4438	0.340	...	2.3323	0.397	2.2211

Corrected Diameters of Circular Forming Tools—3

Length c on Tool	Number 2 B. & S. Machine	Length c on Tool	Number 2 B. & S. Machine	Length c on Tool	Number 2 B. & S. Machine	Length c on Tool	Number 2 B. & S. Machine
0.398	2.2191	0.423	2.1704	0.449	2.1199	0.474	2.0713
0.399	2.2172	0.424	2.1685	0.450	2.1179	0.475	2.0694
0.400	2.2152	0.425	2.1666	0.451	2.1160	0.476	2.0674
0.401	2.2133	0.426	2.1646	0.452	2.1140	0.477	2.0655
0.402	2.2113	0.427	2.1627	0.453	2.1121	0.478	2.0636
0.403	2.2094	0.428	2.1607	$\frac{7}{16}$	2.1101	0.479	2.0616
0.404	2.2074	0.429	2.1588	0.454	2.1101	0.480	2.0597
0.405	2.2055	0.430	2.1568	0.455	2.1082	0.481	2.0577
0.406	2.2035	0.431	2.1549	0.456	2.1063	0.482	2.0558
$\frac{1}{2}$	2.2020	0.432	2.1529	0.457	2.1043	0.483	2.0538
0.407	2.2016	0.433	2.1510	0.458	2.1024	0.484	2.0519
0.408	2.1996	0.434	2.1490	0.459	2.1004	0.485	2.0500
0.409	2.1977	0.435	2.1471	0.460	2.0985	0.486	2.0480
0.410	2.1957	0.436	2.1452	0.461	2.0966	0.487	2.0461
0.411	2.1938	0.437	2.1432	0.462	2.0946	0.488	2.0441
0.412	2.1919	$\frac{1}{4}$	2.1422	0.463	2.0927	0.489	2.0422
0.413	2.1899	0.438	2.1413	0.464	2.0907	0.490	2.0403
0.414	2.1880	0.439	2.1393	0.465	2.0888	0.491	2.0383
0.415	2.1860	0.440	2.1374	0.466	2.0868	0.492	2.0364
0.416	2.1841	0.441	2.1354	0.467	2.0849	0.493	2.0344
0.417	2.1821	0.442	2.1335	0.468	2.0830	0.494	2.0325
0.418	2.1802	0.443	2.1315	$\frac{9}{16}$	2.0815	0.495	2.0306
0.419	2.1782	0.444	2.1296	0.469	2.0810	0.496	2.0286
0.420	2.1763	0.445	2.1276	0.470	2.0791	0.497	2.0267
0.421	2.1743	0.446	2.1257	0.471	2.0771	0.498	2.0247
$\frac{3}{4}$	2.1726	0.447	2.1237	0.472	2.0753	0.499	2.0228
0.422	2.1724	0.448	2.1218	0.473	2.0733	0.500	2.0209

Method of Using Tables for "Corrected Diameters of Circular Forming Tools".—

These tables are especially applicable to Brown & Sharpe automatic screw machines. The maximum diameter  $D$  of forming tools for these machines should be as follows: For No. 00 machine,  $1\frac{1}{4}$  inches; for No. 0 machine,  $2\frac{1}{2}$  inches; for No. 2 machine, 3 inches. To find the other diameters of the tool for any piece to be formed, proceed as follows: Subtract the smallest diameter of the work from the diameter of the work that is to be formed by the required tool diameter; divide the remainder by 2; locate the quotient obtained in the column headed "Length c on Tool," and opposite the figure thus located and in the column headed by the number of the machine used, read off directly the diameter to which the tool is to be made. The quotient obtained, which is located in the column headed "Length c on Tool," is the length  $c$ , as shown in the following table.

Dimensions of Forming Tools for B. & S. Automatic Screw Machines

Diagram	No. of Machine	Max. Dia., $D$	$h$	$T$	$W$
		00	$1\frac{1}{4}$	$\frac{1}{4}$	$\frac{3}{8}$ -16
	0	$2\frac{1}{2}$	$\frac{5}{32}$	$\frac{1}{2}$ -14	$\frac{5}{16}$
	2	3	$\frac{1}{4}$	$\frac{3}{8}$ -12	$\frac{3}{8}$
	6	4	$\frac{3}{16}$	$\frac{3}{4}$ -12	$\frac{3}{8}$

*Example:* A piece of work is to be formed on a No. 0 machine to two diameters, one being  $\frac{1}{4}$  inch and one 0.550 inch; find the diameters of the tool. The maximum tool diameter is  $2\frac{1}{4}$  inches, or the diameter that will cut the  $\frac{1}{4}$ -inch diameter of the work. To find the other diameter, proceed according to the rule given:  $0.550 - \frac{1}{4} = 0.300$ ;  $0.300 \div 2 = 0.150$ . In Table 2, opposite 0.150, we find that the required tool diameter is 1.9534 inches. These tables are for tools without rakes.

**Arrangement of Circular Tools.**—When applying circular tools to automatic screw machines, their arrangement has an important bearing on the results obtained. The various ways of arranging the circular tools, with relation to the rotation of the spindle, are shown at A, B, C, and D in the illustration. These diagrams represent the view obtained when looking toward the chuck. The arrangement shown at A gives good results on long forming operations on brass and steel because the pressure of the cut on the front tool is downward; the support is more rigid than when the forming tool is turned upside down on the front slide, as shown at B; here the stock, turning up toward the tool, has a tendency to lift the cross-slide, causing chattering; therefore, the arrangement shown at A is recommended when a high-quality finish is desired. The arrangement at B works satisfactorily for short steel pieces that do not require a high finish; it allows the chips to drop clear of the work, and is especially advantageous when making screws, when the forming and cut-off tools operate after the die, as no time is lost in reversing the spindle. The arrangement at C is recommended for heavy cutting on large work, when both tools are used for forming the piece; a rigid support is then necessary for both tools and a good supply of oil is also required. The arrangement at D is objectionable and should be avoided; it is used only when a left-hand thread is cut on the piece and when the cut-off tool is used on the front slide, leaving the heavy cutting to be performed from the rear slide. In all "cross-forming" work, it is essential that the spindle bearings be kept in good condition, and that the collet or chuck has a parallel contact upon the bar that is being formed.

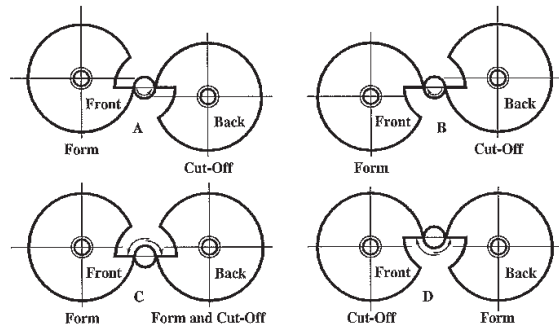

**Feeds and Speeds for Forming Tools.**—Approximate feeds and speeds for forming tools are given in the table beginning on page 1095. The feeds and speeds are average values, and if the job at hand has any features out of the ordinary, the figures given should be altered accordingly.

## MILLING CUTTERS

**Selection of Milling Cutters.**—The most suitable type of milling cutter for a particular milling operation depends on such factors as the kind of cut to be made, the material to be cut, the number of parts to be machined, and the type of milling machine available. Solid cutters of small size will usually cost less, initially, than inserted blade types; for long-run production, inserted-blade cutters will probably have a lower overall cost. Depending on either the material to be cut or the amount of production involved, the use of carbide-tipped cutters in preference to high-speed steel or other cutting tool materials may be justified.

Rake angles depend on both the cutter material and the work material. Carbide and cast alloy cutting tool materials generally have smaller rake angles than high-speed steel tool materials because of their lower edge strength and greater abrasion resistance. Soft work materials permit higher radial rake angles than hard materials; thin cutters permit zero or practically zero axial rake angles; and wide cutters operate smoother with high axial rake angles. See *Rake Angles for Milling Cutters* on page 801.

Cutting edge relief or clearance angles are usually from 3 to 6 degrees for hard or tough materials, 4 to 7 degrees for average materials, and 6 to 12 degrees for easily machined materials. See *Clearance Angles for Milling Cutter Teeth* on page 800.

The number of teeth in the milling cutter is also a factor that should be given consideration, as explained in the next paragraph.

**Number of Teeth in Milling Cutters.**—In determining the number of teeth a milling cutter should have for optimum performance, there is no universal rule.

There are, however, two factors that should be considered in making a choice: 1) The number of teeth should never be so great as to reduce the chip space between the teeth to a point where a free flow of chips is prevented; and 2) The chip space should be smooth and without sharp corners that would cause clogging of the chips in the space.

For milling ductile materials that produce a continuous and curled chip, a cutter with large chip spaces is preferable. Such coarse tooth cutters permit an easier flow of the chips through the chip space than would be obtained with fine tooth cutters, and help to eliminate cutter "chatter." For cutting operations in thin materials, fine tooth cutters reduce cutter and workpiece vibration and the tendency for the cutter teeth to "straddle" the workpiece and dig in. For slitting copper and other soft nonferrous materials, teeth that are either chamfered or alternately flat and V-shaped are best.

As a general rule, to give satisfactory performance the number of teeth in milling cutters should be such that *no more than two teeth at a time are engaged in the cut*. Based on this rule, the following formulas are recommended:

For face milling cutters,

$$T = \frac{6.3D}{W} \quad (1)$$

For peripheral milling cutters,

$$T = \frac{12.6D \cos A}{D + 4d} \quad (2)$$

where  $T$  = number of teeth in cutter;  $D$  = cutter diameter in inches;  $W$  = width of cut in inches;  $d$  = depth of cut in inches; and  $A$  = helix angle of cutter.

To find the number of teeth that a cutter should have when other than two teeth in the cut at the same time is desired, Formulas (1) and (2) should be divided by 2 and the result multiplied by the number of teeth desired in the cut.

*Example:* Determine the required number of teeth in a face mill where  $D = 6$  inches and  $W = 4$  inches. Using Formula (1),

$$T = \frac{6.3 \times 6}{4} = 10 \text{ teeth, approximately}$$

*Example:* Determine the required number of teeth in a plain milling cutter where  $D = 4$  inches and  $d = \frac{1}{4}$  inch. Using Formula (2),

$$T = \frac{12.6 \times 4 \times \cos 0^\circ}{4 + (4 \times \frac{1}{4})} = 10 \text{ teeth, approximately}$$

In *high speed milling* with sintered carbide, high-speed steel, and cast non-ferrous cutting tool materials, a formula that permits full use of the power available at the cutter but prevents overloading of the motor driving the milling machine is:

$$T = \frac{K \times H}{F \times N \times d \times W} \quad (3)$$

where  $T$  = number of cutter teeth;  $H$  = horsepower available at the cutter;  $F$  = feed per tooth in inches;  $N$  = revolutions per minute of cutter;  $d$  = depth of cut in inches;  $W$  = width of cut in inches; and  $K$  = a constant which may be taken as 0.65 for average steel, 1.5 for cast iron, and 2.5 for aluminum. These values are conservative and take into account dulling of the cutter in service.

*Example:* Determine the required number of teeth in a sintered carbide tipped face mill for high speed milling of 200 Brinell hardness alloy steel if  $H = 10$  horsepower;  $F = 0.008$  inch;  $N = 272$  rpm;  $d = 0.125$  inch;  $W = 6$  inches; and  $K$  for alloy steel is 0.65. Using Formula (3),

$$T = \frac{0.65 \times 10}{0.008 \times 272 \times 0.125 \times 6} = 4 \text{ teeth, approximately}$$

**American National Standard Milling Cutters.**—According to American National Standard ANSI/ASME B94.19-1997 milling cutters may be classified in two general ways, which are given as follows:

*By Type of Relief on Cutting Edges:* Milling cutters may be described on the basis of one of two methods of providing relief for the cutting edges. *Profile sharpened* cutters are those on which relief is obtained and which are resharpened by grinding a narrow land back of the cutting edges. Profile sharpened cutters may produce flat, curved, or irregular surfaces. *Form relieved* cutters are those which are so relieved that by grinding only the faces of the teeth the original form is maintained throughout the life of the cutters. Form relieved cutters may produce flat, curved or irregular surfaces.

*By Method of Mounting:* Milling cutters may be described by one of two methods used to mount the cutter. *Arbor type* cutters are those which have a hole for mounting on an arbor and usually have a keyway to receive a driving key. These are sometimes called *Shell type*. *Shank type* cutters are those which have a straight or tapered shank to fit the machine tool spindle or adapter.

**Explanation of the "Hand" of Milling Cutters.**—In the ANSI Standard the terms "right hand" and "left hand" are used to describe hand of rotation, hand of cutter and hand of flute helix.

*Hand of Rotation or Hand of Cut:* is described as either "right hand" if the cutter revolves counterclockwise as it cuts when viewed from a position in front of a horizontal milling machine and facing the spindle or "left hand" if the cutter revolves clockwise as it cuts when viewed from the same position.

American National Standard Plain Milling Cutters ANSI/ASME B94.19-1997

Cutter Diameter			Range of Face Widths Nom. <sup>a</sup>	Hole Diameter		
Nom.	Max.	Min.		Nom.	Max.	Min.
Light-duty Cutters <sup>b</sup>						
2½	2.515	2.485	⅜, ¼, ⅙, ⅛, ½, ⅝, ⅜, 1, 1½, 2 and 3	1	1.00075	1.0000
3	3.015	2.985	⅜, ¼, ⅙, ⅛, ⅝, ⅜, and 1½	1	1.00075	1.0000
3	3.015	2.985	½, ⅝, ⅜, 1, 1¼, 1½, 2 and 3	1¼	1.2510	1.2500
4	4.015	3.985	¼, ⅙ and ⅛	1	1.00075	1.0000
4	4.015	3.985	⅜, ½, ⅝, ⅜, 1, 1½, 2, 3 and 4	1¼	1.2510	1.2500
Heavy-duty Cutters <sup>c</sup>						
2½	2.515	2.485	2	1	1.00075	1.0000
2½	2.515	2.485	4	1	1.0010	1.0000
3	3.015	2.985	2, 2½, 3, 4 and 6	1¼	1.2510	1.2500
4	4.015	3.985	2, 3, 4 and 6	1½	1.5010	1.5000
High-helix Cutters <sup>d</sup>						
3	3.015	2.985	4 and 6	1¼	1.2510	1.2500
4	4.015	3.985	8	1½	1.5010	1.5000

<sup>a</sup>Tolerances on Face Widths: Up to 1 inch, inclusive, ± 0.001 inch; over 1 to 2 inches, inclusive, +0.010, -0.000 inch; over 2 inches, +0.020, -0.000 inch.

<sup>b</sup>Light-duty plain milling cutters with face widths under ¼ inch have straight teeth. Cutters with ¼-inch face and wider have helix angles of not less than 15 degrees nor greater than 25 degrees.

<sup>c</sup>Heavy-duty plain milling cutters have a helix angle of not less than 25 degrees nor greater than 45 degrees.

<sup>d</sup>High-helix plain milling cutters have a helix angle of not less than 45 degrees nor greater than 52 degrees.

All dimensions are in inches. All cutters are high-speed steel. Plain milling cutters are of cylindrical shape, having teeth on the peripheral surface only.

**Hand of Cutter:** Some types of cutters require special consideration when referring to their hand. These are principally cutters with unsymmetrical forms, face type cutters, or cutters with threaded holes. *Symmetrical* cutters may be reversed on the arbor in the same axial position and rotated in the cutting direction without altering the contour produced on the work-piece, and may be considered as either right or left hand. *Unsymmetrical* cutters reverse the contour produced on the work-piece when reversed on the arbor in the same axial position and rotated in the cutting direction. A *single-angle* cutter is considered to be a right-hand cutter if it revolves counterclockwise, or a left-hand cutter if it revolves clockwise, when cutting as viewed from the side of the larger diameter. The *hand of rotation* of a single angle milling cutter need not necessarily be the same as its *hand of cutter*. A *single corner rounding* cutter is considered to be a right-hand cutter if it revolves counterclockwise, or a left-hand cutter if it revolves clockwise, when cutting as viewed from the side of the smaller diameter.



American National Standard Side Milling Cutters ANSIS/ASME B94.19-1997

Cutter Diameter			Range of Face Widths Nom. <sup>a</sup>	Hole Diameter		
Nom.	Max.	Min.		Nom.	Max.	Min.
Side Cutters <sup>b</sup>						
2	2.015	1.985	$\frac{1}{16}, \frac{1}{8}, \frac{3}{16}$	$\frac{3}{8}$	0.62575	0.6250
2½	2.515	2.485	$\frac{1}{4}, \frac{5}{16}, \frac{1}{2}$	$\frac{3}{8}$	0.87575	0.8750
3	3.015	2.985	$\frac{1}{4}, \frac{5}{16}, \frac{3}{8}, \frac{7}{16}, \frac{1}{2}$	1	1.00075	1.0000
4	4.015	3.985	$\frac{1}{4}, \frac{5}{16}, \frac{3}{8}, \frac{7}{16}, \frac{1}{2}$	1	1.00075	1.0000
4	4.015	3.985	$\frac{1}{2}, \frac{5}{8}, \frac{3}{4}$	1½	1.2510	1.2500
5	5.015	4.985	$\frac{1}{2}, \frac{5}{8}, \frac{3}{4}$	1	1.00075	1.0000
5	5.015	4.985	$\frac{1}{2}, \frac{5}{8}, \frac{3}{4}, 1$	1½	1.2510	1.2500
6	6.015	5.985	$\frac{1}{2}$	1	1.00075	1.0000
6	6.015	5.985	$\frac{1}{2}, \frac{5}{8}, \frac{3}{4}, 1$	1½	1.2510	1.2500
7	7.015	6.985	$\frac{3}{4}$	1½	1.2510	1.2500
7	7.015	6.985	$\frac{3}{4}$	1½	1.5010	1.5000
8	8.015	7.985	$\frac{3}{4}, 1$	1½	1.2510	1.2500
8	8.015	7.985	$\frac{3}{4}, 1$	1½	1.5010	1.5000
Staggered-tooth Side Cutters <sup>c</sup>						
2½	2.515	2.485	$\frac{1}{4}, \frac{5}{16}, \frac{3}{8}, \frac{1}{2}$	$\frac{3}{8}$	0.87575	0.8750
3	3.015	2.985	$\frac{1}{4}, \frac{5}{16}, \frac{3}{8}, \frac{7}{16}$	1	1.00075	1.0000
3	3.015	2.985	$\frac{1}{2}, \frac{5}{8}, \frac{3}{4}$	1½	1.2510	1.2500
4	4.015	3.985	$\frac{1}{4}, \frac{5}{16}, \frac{3}{8}, \frac{7}{16}, \frac{1}{2}$ , $\frac{3}{8}, \frac{7}{16}$ and $\frac{1}{2}$	1½	1.2510	1.2500
5	5.015	4.985	$\frac{1}{2}, \frac{5}{8}, \frac{3}{4}$	1½	1.2510	1.2500
6	6.015	5.985	$\frac{3}{8}, \frac{1}{2}, \frac{5}{8}, \frac{3}{4}, 1$	1½	1.2510	1.2500
8	8.015	7.985	$\frac{3}{8}, \frac{1}{2}, \frac{5}{8}, \frac{3}{4}, 1$	1½	1.5010	1.5000
Half Side Cutters <sup>d</sup>						
4	4.015	3.985	$\frac{3}{8}$	1½	1.2510	1.2500
5	5.015	4.985	$\frac{3}{8}$	1½	1.2510	1.2500
6	6.015	5.985	$\frac{3}{8}$	1½	1.2510	1.2500

<sup>a</sup>Tolerances on Face Widths: For side cutters, +0.002, -0.001 inch; for staggered-tooth side cutters up to  $\frac{3}{4}$  inch face width, inclusive, +0.000 -0.0005 inch, and over  $\frac{3}{4}$  to 1 inch, inclusive, +0.000 -0.0010 inch; and for half side cutters, +0.015, -0.000 inch.

<sup>b</sup>Side milling cutters have straight peripheral teeth and side teeth on both sides.

<sup>c</sup>Staggered-tooth side milling cutters have peripheral teeth of alternate right- and left-hand helix and alternate side teeth.

<sup>d</sup>Half side milling cutters have side teeth on one side only. The peripheral teeth are helical of the same hand as the cut. Made either with right-hand or left-hand cut.

All dimensions are in inches. All cutters are high-speed steel. Side milling cutters are of cylindrical shape, having teeth on the periphery and on one or both sides.

**Hand of Flute Helix:** Milling cutters may have *straight flutes* which means that their cutting edges are in planes parallel to the cutter axis. Milling cutters with flute helix in one direction only are described as having a right-hand helix if the flutes twist away from the observer in a clockwise direction when viewed from either end of the cutter or as having a left-hand helix if the flutes twist away from the observer in a counterclockwise direction when viewed from either end of the cutter. *Staggered tooth cutters* are milling cutters with every other flute of opposite (right and left hand) helix.

An illustration describing the various milling cutter elements of both a profile cutter and a form-relieved cutter is given on page 776.

**American National Standard Staggered Teeth, T-Slot Milling Cutters with Brown & Sharpe Taper and Weldon Shanks ANSI/ASME B94.19-1997**

Bolt Size	Cutter Dia., D	Face Width, W	Neck Dia., N	With B. & S. Taper <sup>a,b</sup>		With Weldon Shank	
				Length, L	Taper No.	Length, L	Dia., S
1/4	3/16	1/16	1/16	...	...	2 3/16	1/2
3/16	1/4	1/8	1/8	...	...	2 1/2	1/2
1/2	5/16	3/16	1/4	...	...	3 1/4	3/4
5/8	3/8	1/4	1/4	5	7	3 3/4	3/4
3/4	1/2	3/8	3/8	5 1/2	7	3 3/4	1
7/8	5/8	1/2	1/2	6 1/4	9	4 3/8	1
1	3/4	5/8	3/4	7 1/4	9	4 3/8	1 1/4

<sup>a</sup>For dimensions of Brown & Sharpe taper shanks, see information given on page 916.  
<sup>b</sup>Brown & Sharpe taper shanks have been removed from ANSI/ASME B94.19 they are included for reference only.  
 All dimensions are in inches. All cutters are high-speed steel and only right-hand cutters are standard.  
 Tolerances: On D, +0.000, -0.010 inch; on W, +0.000, -0.005 inch; on N, +0.000, -0.005 inch; on L, ± 1/16 inch; on S, -0.0001 to -0.0005 inch.

**American National Standard Form Relieved Corner Rounding Cutters with Weldon Shanks ANSI/ASME B94.19-1997**

Rad., R	Dia., D	Dia., d	S	L	Rad., R	Dia., D	Dia., d	S	L
1/16	3/16	1/16	3/8	2 1/2	3/16	1/4	3/16	1/2	3 1/2
1/8	1/4	1/8	3/8	2 1/2	3/16	3/8	3/16	3/4	3 1/4
1/4	3/8	1/4	1/2	3	1/4	1	3/8	3/4	3 1/4
3/8	1/2	3/8	1/2	3	3/8	1 1/4	3/8	3/4	3 1/2
1/2	5/8	1/2	3/4	3	1/2	1 3/4	3/8	1	3 3/4
3/4	3/4	3/4	1	3	3/4	2 1/4	3/8	1	4
5/8	1	5/8	1 1/4	3 1/4	1/2	1 1/2	3/8	1	4 1/4

All dimensions are in inches. All cutters are high-speed steel. Right-hand cutters are standard.  
 Tolerances: On D, ±0.010 inch; on diameter of circle, 2R, ±0.001 inch for cutters up to and including 1/8-inch radius, +0.002, -0.001 inch for cutters over 1/8-inch radius; on S, -0.0001 to -0.0005 inch; and on L, ± 1/16 inch.

American National Standard Metal Slitting Saws ANS/ASME B94.19-1997

Cutter Diameter			Range of Face Widths Nom. <sup>a</sup>	Hole Diameter		
Nom.	Max.	Min.		Nom.	Max.	Min.
Plain Metal Slitting Saws <sup>b</sup>						
2½	2.515	2.485	⅜, ⅜, ⅜, ⅜, ⅜	⅜	0.87575	0.8750
3	3.015	2.985	⅜, ⅜, ⅜, ⅜, ⅜, ⅜, ⅜, ⅜	1	1.00075	1.0000
4	4.015	3.985	⅜, ⅜, ⅜, ⅜, ⅜, ⅜, ⅜, ⅜, ⅜, ⅜	1	1.00075	1.0000
5	5.015	4.985	⅜, ⅜, ⅜, ⅜, ⅜, ⅜, ⅜, ⅜, ⅜, ⅜, ⅜, ⅜	1	1.00075	1.0000
5	5.015	4.985	⅜, ⅜, ⅜, ⅜, ⅜, ⅜, ⅜, ⅜, ⅜, ⅜, ⅜, ⅜	1¼	1.2510	1.2500
6	6.015	5.985	⅜, ⅜, ⅜, ⅜, ⅜, ⅜, ⅜, ⅜, ⅜, ⅜, ⅜, ⅜, ⅜	1	1.00075	1.0000
6	6.015	5.985	⅜, ⅜, ⅜, ⅜, ⅜, ⅜, ⅜, ⅜, ⅜, ⅜, ⅜, ⅜, ⅜	1¼	1.2510	1.2500
8	8.015	7.985	⅜, ⅜, ⅜, ⅜, ⅜, ⅜, ⅜, ⅜, ⅜, ⅜, ⅜, ⅜, ⅜, ⅜	1	1.00075	1.0000
8	8.015	7.985	⅜, ⅜, ⅜, ⅜, ⅜, ⅜, ⅜, ⅜, ⅜, ⅜, ⅜, ⅜, ⅜, ⅜	1¼	1.2510	1.2500
Metal Slitting Saws with Side Teeth <sup>c</sup>						
2½	2.515	2.485	⅜, ⅜, ⅜, ⅜, ⅜	⅜	0.87575	0.8750
3	3.015	2.985	⅜, ⅜, ⅜, ⅜, ⅜, ⅜, ⅜, ⅜	1	1.00075	1.0000
4	4.015	3.985	⅜, ⅜, ⅜, ⅜, ⅜, ⅜, ⅜, ⅜, ⅜, ⅜	1	1.00075	1.0000
5	5.015	4.985	⅜, ⅜, ⅜, ⅜, ⅜, ⅜, ⅜, ⅜, ⅜, ⅜, ⅜, ⅜	1	1.00075	1.0000
5	5.015	4.985	⅜, ⅜, ⅜, ⅜, ⅜, ⅜, ⅜, ⅜, ⅜, ⅜, ⅜, ⅜	1¼	1.2510	1.2500
6	6.015	5.985	⅜, ⅜, ⅜, ⅜, ⅜, ⅜, ⅜, ⅜, ⅜, ⅜, ⅜, ⅜, ⅜	1	1.00075	1.0000
6	6.015	5.985	⅜, ⅜, ⅜, ⅜, ⅜, ⅜, ⅜, ⅜, ⅜, ⅜, ⅜, ⅜, ⅜	1¼	1.2510	1.2500
8	8.015	7.985	⅜, ⅜, ⅜, ⅜, ⅜, ⅜, ⅜, ⅜, ⅜, ⅜, ⅜, ⅜, ⅜, ⅜	1	1.00075	1.0000
8	8.015	7.985	⅜, ⅜, ⅜, ⅜, ⅜, ⅜, ⅜, ⅜, ⅜, ⅜, ⅜, ⅜, ⅜, ⅜	1¼	1.2510	1.2500
Metal Slitting Saws with Staggered Peripheral and Side Teeth <sup>d</sup>						
3	3.015	2.985	⅜	1	1.00075	1.0000
4	4.015	3.985	⅜	1	1.00075	1.0000
5	5.015	4.985	⅜, ⅜	1	1.00075	1.0000
6	6.015	5.985	⅜, ⅜	1	1.00075	1.0000
6	6.015	5.985	⅜, ⅜	1¼	1.2510	1.2500
8	8.015	7.985	⅜, ⅜	1¼	1.2510	1.2500
10	10.015	9.985	⅜, ⅜	1¼	1.2510	1.2500
12	12.015	11.985	⅜, ⅜	1½	1.5010	1.5000

<sup>a</sup>Tolerances on face widths are plus or minus 0.001 inch.  
<sup>b</sup>Plain metal slitting saws are relatively thin plain milling cutters having peripheral teeth only. They are furnished with or without hub and their sides are concaved to the arbor hole or hub.  
<sup>c</sup>Metal slitting saws with side teeth are relatively thin side milling cutters having both peripheral and side teeth.  
<sup>d</sup>Metal slitting saws with staggered peripheral and side teeth are relatively thin staggered tooth milling cutters having peripheral teeth of alternate right- and left-hand helix and alternate side teeth.  
 All dimensions are in inches. All saws are high-speed steel. Metal slitting saws are similar to plain or side milling cutters but are relatively thin.

Milling Cutter Terms

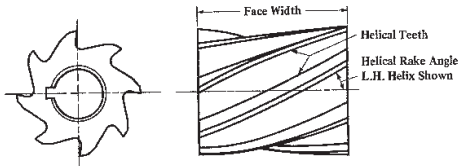

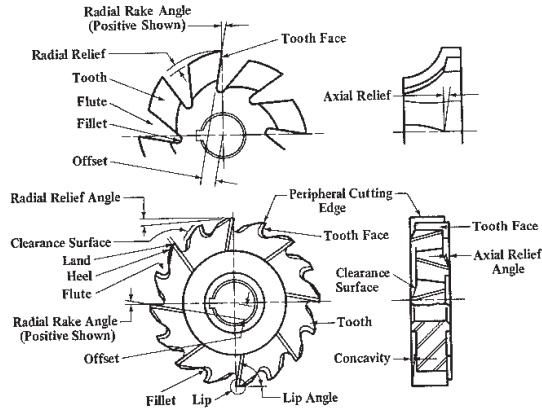

American National Standard Single- and Double-Angle Milling Cutters ANSI/ASME B94.19-1997

Cutter Diameter			Nominal Face Width <sup>a</sup>	Hole Diameter		
Nom.	Max.	Min.		Nom.	Max.	Min.
Single-angle Cutters <sup>b</sup>						
1 1/4	1.265	1.235	3/8	1/2-24 UNF-2B RH 3/8-24 UNF-2B LH		
1 3/8	1.640	1.610	5/16	1/2-20 UNF-2B RH		
2 1/4	2.765	2.735	1/2	1	1.0075	1.0000
3	3.015	2.985	1/2	1 1/4	1.2516	1.2500
Double-angle Cutters <sup>d</sup>						
2 3/4	2.765	2.735	1/2	1	1.0075	1.0000

<sup>a</sup>Face width tolerances are plus or minus 0.015 inch.

<sup>b</sup>Single-angle milling cutters have peripheral teeth, one cutting edge of which lies in a conical surface and the other in the plane perpendicular to the cutter axis. There are two types: one has a plain keywayed hole and has an included tooth angle of either 45 or 60 degrees plus or minus 10 minutes; the other has a threaded hole and has an included tooth angle of 60 degrees plus or minus 10 minutes. Cutters with a right-hand threaded hole have a right-hand hand of rotation and a right-hand hand of cutter. Cutters with a left-hand threaded hole have a left-hand hand of rotation and a left-hand hand of cutter. Cutters with plain keywayed holes are standard as either right-hand or left-hand cutters.

<sup>c</sup>These cutters have threaded holes, the sizes of which are given under "Hole Diameter."

<sup>d</sup>Double-angle milling cutters have symmetrical peripheral teeth both sides of which lie in conical surfaces. They are designated by the included angle, which may be 45, 60 or 90 degrees. Tolerances are plus or minus 10 minutes for the half angle on each side of the center.

All dimensions are in inches. All cutters are high-speed steel.

American National Standard Shell Mills ANSIA/SME B94.19-1997

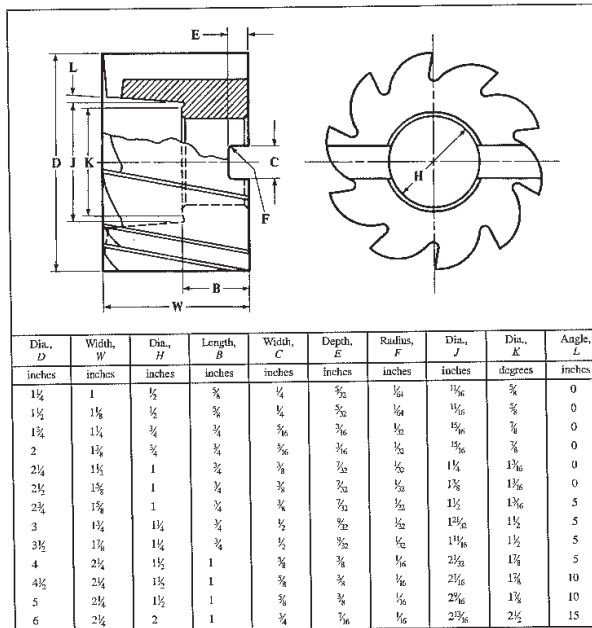

All cutters are high-speed steel. Right-hand cutters with right-hand helix and square corners are standard.

Tolerances: On D, +1/64 inch; on W, ±1/64 inch; on H, +0.0005 inch; on B, +1/64 inch; on C, at least +0.008 but not more than +0.012 inch; on E, +1/64 inch; on J, ±1/64 inch; on K, ±1/64 inch.

End Mill Terms

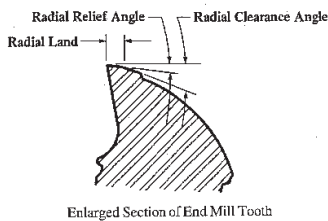

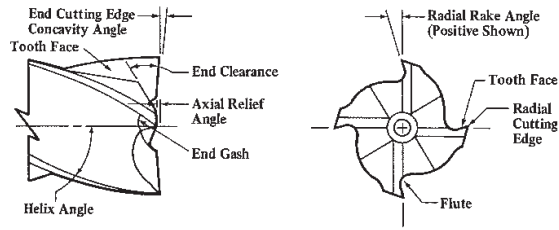

Enlarged Section of End Mill

American National Standard Multiple- and Two-Flute Single-End Helical End Mills with Plain Straight and Weldon Shanks ANS/ASME B94.19-1997

Cutter Diameter, <i>D</i>		Shank Diameter, <i>S</i>		Length of Cut, <i>W</i>	Length Overall, <i>L</i>	
Nom.	Max.	Max.	Min.			
Multiple-flute with Plain Straight Shanks						
3/8	.130	.125	.125	.1245	1 1/4	
1/2	.1925	.1875	.1875	.1870	1 3/4	
3/4	.255	.250	.250	.2495	1 7/8	
1	.380	.375	.375	.3745	1 5/8	
1 1/4	.505	.500	.500	.4995	2 1/4	
1 1/2	.755	.750	.750	.7495	2 3/4	
Two-flute for Keyway Cutting with Weldon Shanks						
3/8	.125	.1235	.375	.3745	3/8	2 3/8
1/2	.1875	.1860	.375	.3745	7/8	2 5/8
3/4	.250	.2485	.375	.3745	1 1/2	2 7/8
1	.3125	.3110	.375	.3745	1 3/4	2 3/4
1 1/4	.375	.3735	.375	.3745	1 3/4	2 3/4
1 1/2	.500	.4985	.500	.4995	1	3
1 3/4	.625	.6235	.625	.6245	1 1/4	3 1/8
2	.750	.7485	.750	.7495	1 3/4	3 1/4
2 1/4	.875	.8735	.875	.8745	1 1/2	3 3/4
2 1/2	1.000	.9985	1.000	.9995	1 3/4	4 1/4
2 3/4	1.250	1.2485	1.250	1.2495	1 3/4	4 1/4
3	1.500	1.4985	1.250	1.2495	1 3/4	4 1/4

All dimensions are in inches. All cutters are high-speed steel. Right-hand cutters with right-hand helix are standard.

The helix angle is not less than 10 degrees for multiple-flute cutters with plain straight shanks; the helix angle is optional with the manufacturer for two-flute cutters with Weldon shanks.

Tolerances: On *W*, ±1/32 inch; on *L*, ±1/16 inch.

ANSI Regular-, Long-, and Extra Long-Length, Multiple-Flute Medium Helix Single-End End Mills with Weldon Shanks ANSI/ASME B94.19-1997

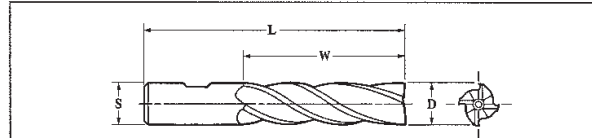

As Indicated By The Dimensions Given Below, Shank Diameter S May Be Larger, Smaller, Or The Same As The Cutter Diameter D

Cutter Dia., D	Regular Mills				Long Mills				Extra Long Mills			
	S	W	L	N <sup>a</sup>	S	W	L	N <sup>a</sup>	S	W	L	N <sup>a</sup>
3/8 <sup>b</sup>	3/8	3/8	2 1/16	4	...	...	...	...	...	...	...	...
3/8 <sup>b</sup>	3/8	1/2	2 3/16	4	...	...	...	...	...	...	...	...
1/2 <sup>b</sup>	3/8	3/8	2 1/16	4	3/8	1 1/4	3 3/8	4	3/8	1 3/4	3 3/4	4
3/8 <sup>b</sup>	3/8	3/8	2 1/2	4	3/8	1 3/8	3 1/2	4	3/8	2	3 3/4	4
3/8 <sup>b</sup>	3/8	3/4	2 1/2	4	3/8	1 1/2	3 1/2	4	3/8	2 1/2	4 1/2	4
7/16	3/8	1	2 11/16	4	1/2	1 3/4	3 3/4	4	...	...	...	...
1/2	3/8	1	2 3/8	4	1/2	2	4	4	1/2	3	5	4
1/2 <sup>b</sup>	1/2	1 1/4	3 1/4	4	...	...	...	...	...	...	...	...
5/16	1/2	1 3/8	3 3/8	4	...	...	...	...	...	...	...	...
3/8	1/2	1 3/8	3 3/8	4	3/8	2 1/2	4 3/8	4	3/8	4	6 1/8	4
11/16	1/2	1 3/8	3 3/8	4	...	...	...	...	...	...	...	...
3/4	1/2	1 3/8	3 3/8	4	3/4	3	5 1/4	4	3/4	4	6 1/4	4
3/8 <sup>b</sup>	3/8	1 3/8	3 3/8	4	...	...	...	...	...	...	...	...
11/16	3/8	1 3/8	3 3/8	4	...	...	...	...	...	...	...	...
3/4 <sup>b</sup>	3/8	1 3/8	3 3/8	4	...	...	...	...	...	...	...	...
11/16	3/8	1 3/8	3 3/8	4	...	...	...	...	...	...	...	...
3/8	3/8	1 7/8	4	6	...	...	...	...	...	...	...	...
3/8	3/8	1 7/8	4	6	3/8	3 1/2	5 3/8	4	3/8	5	7 1/4	4
1	3/8	1 7/8	4	6	1	4	6 1/2	4	1	6	8 1/2	4
3/8	3/8	1 7/8	4 1/8	4	...	...	...	...	...	...	...	...
1	3/8	1 7/8	4 1/8	4	...	...	...	...	...	...	...	...
1 1/4	3/8	2	4 1/4	6	1	4	6 1/2	6	...	...	...	...
1 1/4	3/8	2	4 1/4	6	1	4	6 1/2	6	1 1/4	6	8 1/2	6
1	1	2	4 1/2	4	...	...	...	...	...	...	...	...
1 1/4	1	2	4 1/2	6	...	...	...	...	...	...	...	...
1 1/4	1	2	4 1/2	6	...	...	...	...	...	...	...	...
1 3/8	1	2	4 1/2	6	...	...	...	...	...	...	...	...
1 1/2	1	2	4 1/2	6	1	4	6 1/2	6	...	...	...	...
1 1/4	1 1/4	2	4 1/2	6	1 1/4	4	6 1/2	6	...	...	...	...
1 1/2	1 1/4	2	4 1/2	6	1 1/4	4	6 1/2	6	1 1/4	8	10 1/2	6
1 3/4	1 1/4	2	4 1/2	6	1 1/4	4	6 1/2	6	...	...	...	...
2	1 1/4	2	4 1/2	8	1 1/4	4	6 1/2	8	...	...	...	...

<sup>a</sup>N = Number of flutes.

<sup>b</sup>In this size of regular mill a left-hand cutter with left-hand helix is also standard.

All dimensions are in inches. All cutters are high-speed steel. Helix angle is greater than 19 degrees but not more than 39 degrees. Right-hand cutters with right-hand helix are standard.

Tolerances: On D, +0.003 inch; on S, -0.0001 to -0.0005 inch; on W, ±1/32 inch; on L, ±1/16 inch.

**ANSI Two-Flute, High Helix, Regular-, Long-, and Extra Long-Length, Single-End End Mills with Weldon Shanks ANSI/ASME B94.19-1997**

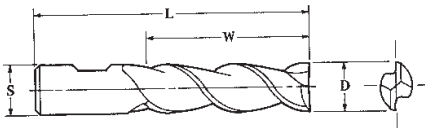

Cutter Dia. D	Regular Mill			Long Mill			Extra Long Mill		
	S	W	L	S	W	L	S	W	L
1/4	3/8	3/8	2 3/8	3/8	1 1/4	3 3/8	3/8	1 3/4	3 3/8
5/16	3/8	3/8	2 1/2	3/8	1 3/8	3 1/2	3/8	2	3 3/4
3/8	3/8	3/8	2 1/2	3/8	1 1/2	3 3/4	3/8	2 1/2	4 1/4
7/16	3/8	1	2 3/4	1/2	1 3/4	3 3/4	...	...	...
1/2	1/2	1 1/4	3 1/4	1/2	2	4	1/2	3	5
5/8	3/8	1 3/8	3 3/4	3/8	2 1/2	4 3/8	3/8	4	6 1/8
3/4	3/4	1 3/8	3 3/4	3/8	3	5 1/4	3/8	4	6 3/4
7/8	3/8	1 1/2	4 1/8	...	...	...	...	...	...
1	1	2	4 1/2	1	4	6 1/2	1	6	8 1/2
1 1/4	1 1/4	2	4 1/2	1 1/4	4	6 1/2	1 1/4	6	8 1/2
1 1/2	1 1/4	2	4 1/2	1 1/4	4	6 1/2	1 1/4	8	10 1/2
2	1 1/4	2	4 1/2	1 1/4	4	6 1/2	...	...	...

All dimensions are in inches. All cutters are high-speed steel. Right-hand cutters with right-hand helix are standard. Helix angle is greater than 39 degrees.  
 Tolerances: On D, +0.003 inch; on S, -0.0001 to -0.0005 inch; on W, ±1/32 inch; and on L, ±1/16 inch.

**Combination Shanks for End Mills ANSI/ASME B94.19-1997**

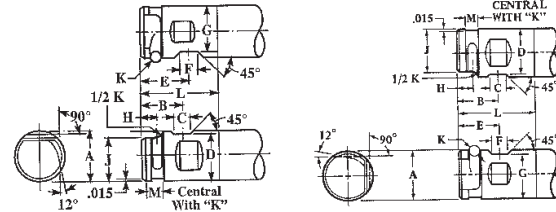

Di. A	L*	B	C	D	E	F	G	H	J	K	M
1 1/2	2 1/16	1 3/8	.515	1.406	1 1/2	.515	1.371	3/8	1.302	.377	3/8
2	3 1/4	1 3/8	.700	1.909	1 3/4	.700	1.809	3/8	1.772	.440	1/2
2 1/2	3 1/2	1 3/8	.700	2.400	2	.700	2.312	3/4	2.245	.503	3/8

\*Length of shank.  
 All dimensions are in inches.  
 Modified for use as Weldon or Pin Drive shank.



**ANSI Roughing, Single-End End Mills with Weldon Shanks, High-Speed Steel**  
ANSI/ASME B94.19-1997

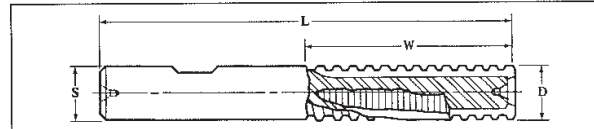

Diameter		Length		Diameter		Length	
Cutter D	Shank S	Cut W	Overall L	Cutter D	Shank S	Cut W	Overall L
1/2	1/2	1	3	2	2	2	5 1/2
1/2	1/2	1 1/2	3 1/2	2	2	3	6 1/2
1/2	1/2	2	4	2	2	4	7 1/2
3/8	3/8	1 1/4	3 3/4	2	2	5	8 1/2
3/8	3/8	1 3/4	3 3/4	2	2	6	9 1/2
3/8	3/8	2 1/4	4 1/4	2	2	7	10 1/2
3/8	3/8	1 1/2	3 1/2	2	2	8	11 1/2
3/8	3/8	1 3/4	3 3/4	2	2	10	13 1/2
3/8	3/8	3	5 1/2	2	2	12	15 1/2
1	1	2	4 1/2	2 1/2	2	4	7 3/4
1	1	4	6 1/2	2 1/2	2	6	9 3/4
1 1/4	1 1/4	2	4 1/2	2 1/2	2	8	11 3/4
1 1/4	1 1/4	4	6 1/2	2 1/2	2	10	13 3/4
1 1/2	1 1/2	2	4 1/2	3	2 1/2	4	7 3/4
1 1/2	1 1/2	4	6 1/2	3	2 1/2	6	9 3/4
1 3/4	1 3/4	2	4 1/2	3	2 1/2	8	11 3/4
1 3/4	1 3/4	4	6 1/2	3	2 1/2	10	13 3/4

All dimensions are in inches. Right-hand cutters with right-hand helix are standard.  
Tolerances: Outside diameter, +0.025, -0.005 inch; length of cut, +1/16, -1/32 inch.

**American National Standard Heavy Duty, Medium Helix Single-End End Mills,**  
**2 1/2-inch Combination Shank, High-Speed Steel** ANSI/ASME B94.19-1997

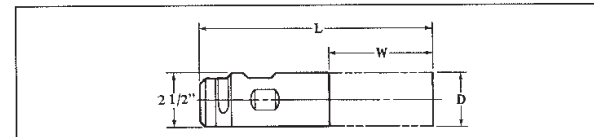

Dia. of Cutter, D	No. of Flutes	Length of Cut, W	Length Overall, L	Dia. of Cutter, D	No. of Flutes	Length of Cut, W	Length Overall, L
2 1/2	3	8	12	3	3	4	7 1/2
2 1/2	3	10	14	3	3	6	9 1/2
2 1/2	6	4	8	3	3	8	11 1/2
2 1/2	6	6	10	3	8	4	7 1/2
2 1/2	6	8	12	3	8	6	9 1/2
2 1/2	6	10	14	3	8	8	11 1/2
2 1/2	6	12	16	3	8	10	13 1/2
3	2	4	7 1/2	3	8	12	15 1/2
3	2	6	9 1/2	...	...	...	...

All dimensions are in inches. For shank dimensions see page 781. Right-hand cutters with right-hand helix are standard. Helix angle is greater than 19 degrees but not more than 39 degrees.  
Tolerances: On D, +0.005 inch; on W, ±1/32 inch; on L, ±1/16 inch.

**ANSI Stub-, Regular-, and Long-Length, Four-Flute, Medium Helix, Plain-End, Double-End Miniature End Mills with 3/16-Inch Diameter Straight Shanks**  
ANSI/ASME B94.19-1997

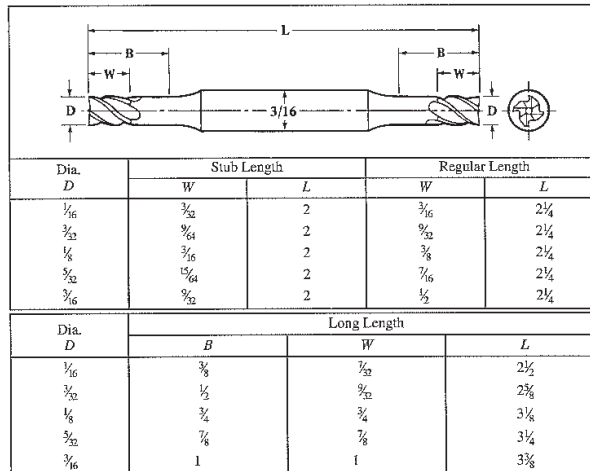

All dimensions are in inches. All cutters are high-speed steel. Right-hand cutters with right-hand helix are standard. Helix angle is greater than 19 degrees but not more than 39 degrees.

Tolerances: On D, +0.003 inch (if the shank is the same diameter as the cutting portion, however, then the tolerance on the cutting diameter is -0.0025 inch.); on W, +1/32, -1/64 inch; and on L, ±1/16 inch.

**American National Standard 60-Degree Single-Angle Milling Cutters with Weldon Shanks** ANSI/ASME B94.19-1997

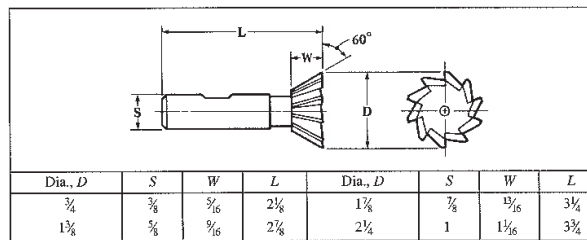

All dimensions are in inches. All cutters are high-speed steel. Right-hand cutters are standard.

Tolerances: On D, ±0.015 inch; on S, -0.0001 to -0.0005 inch; on W, ±0.015 inch; and on L, ±1/16 inch.

**American National Standard Stub-, Regular-, and Long-Length, Two-Flute, Medium Helix, Plain- and Ball-End, Double-End Miniature End Mills with 3/16-Inch Diameter Straight Shanks ANS/ASME B94.19-1997**

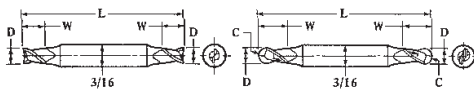

Dia., C and D	Sub Length				Regular Length			
	Plain End		Ball End		Plain End		Ball End	
	W	L	W	L	W	L	W	L
1/32	3/64	2	...	...	3/32	2 1/2	...	...
3/64	3/32	2	...	...	3/32	2 1/2	...	...
1/16	3/32	2	1/32	...	3/32	2 1/2	3/16	2 1/2
3/64	3/32	2	...	...	3/64	2 1/2	...	...
1/32	3/64	2	3/64	2	3/32	2 1/2	3/32	2 1/2
3/64	3/64	2	...	...	3/64	2 1/2	...	...
1/16	3/64	2	3/16	2	3/32	2 1/2	3/16	2 1/2
3/64	3/32	2	...	...	3/32	2 1/2	...	...
1/32	3/64	2	15/64	2	3/16	2 1/2	7/32	2 1/2
3/64	3/32	2	...	...	3/16	2 1/2	...	...
1/16	3/32	2	3/32	2	3/16	2 1/2	3/16	2 1/2

  

Dia., D	Long Length		
	B*	W	L
1/16	3/8	3/16	2 1/2
3/32	1/2	3/16	2 3/4
1/8	3/4	3/8	3 1/4
3/16	5/8	3/4	3 3/4

\*B is the length below the shank.

All dimensions are in inches. All cutters are high-speed steel. Right-hand cutters with right-hand helix are standard. Helix angle is greater than 19 degrees but not more than 39 degrees.  
 Tolerances: On C and D, -0.0015 inch for stub and regular length; +0.003 inch for long length (if the shank is the same diameter as the cutting portion, however, then the tolerance on the cutting diameter is -0.0025 inch.); on W, +1/32, -1/64 inch; and on L, ±1/16 inch.

**American National Standard Multiple Flute, Helical Series End Mills with Brown & Sharpe Taper Shanks**

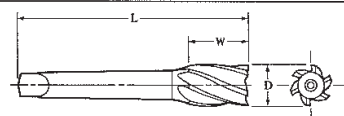

Dia., D	W	L	Taper No.	Dia., D	W	L	Taper No.
...	...	...	...	1	1 1/4	5 3/4	7
...	...	...	...	1 1/4	2	7 1/4	9
1/2	3/8	4 3/8	7	1 1/2	2 1/4	7 1/2	9
3/4	1 1/4	5 1/2	7	2	2 3/4	8	9

All dimensions are in inches. All cutters are high-speed steel. Right-hand cutters with right-hand helix are standard. Helix angle is not less than 10 degrees.  
 No. 5 taper is standard without tang; Nos. 7 and 9 are standard with tang only.  
 Tolerances: On D, +0.005 inch; on W, ±1/32 inch; and on L, ±1/16 inch.  
 For dimensions of B & S taper shanks, see information given on page 916.

American National Standard Stub- and Regular-Length, Two-Flute, Medium Helix, Plain- and Ball-End, Single-End End Mills with Weldon Shanks  
ANSI/ASME B94.19-1997

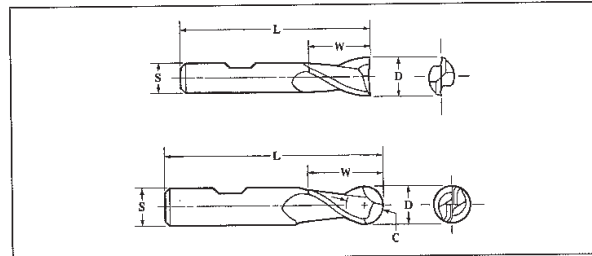

Regular Length — Plain End				Stub Length — Plain End			
Dia., D	S	W	L	Cutter Dia., D	Shank Dia., S	Length of Cut. W	Length Overall L
1/8	3/8	3/8	2 3/16	1/8	3/8	3/8	2 1/8
3/16	3/8	3/8	2 1/8	3/16	3/8	3/8	2 7/16
1/4	3/8	1/2	2 1/8	1/4	3/8	3/8	2 1/4
5/16	3/8	5/16	2 1/8	Regular Length — Ball End			
3/8	3/8	3/8	2 1/8				
7/16	3/8	3/8	2 1/2	Dia., C and D	Shank Dia., S	Length of Cut. W	Length Overall L
1/2	3/8	1 1/8	3	1/2	3/8	3/8	2 3/8
5/8	1/2	1 1/2	3 1/2	5/8	3/8	3/8	2 3/4
3/4	1/2	1 5/8	3 5/8	3/4	3/8	3/8	2 3/4
7/8	1/2	1 7/8	3 7/8	7/8	3/8	3/8	2 3/4
1	1/2	2	4	1	3/8	3/8	2 3/4
1 1/8	3/4	2 1/8	4 1/8	1 1/8	1/2	1	3
1 1/4	3/4	2 1/4	4 1/4	1 1/4	1/2	1 1/4	3 1/8
1 1/2	3/4	2 1/2	4 1/2	1 1/2	1/2	1 1/2	3 1/4
1 3/4	3/4	2 3/4	4 3/4	1 3/4	1/2	1 3/4	3 1/2
1 7/8	3/4	2 7/8	4 7/8	1 7/8	1/2	1 7/8	3 5/8
2	3/4	3	5	2	1/2	2	4
2 1/8	1	3 1/8	5 1/8	2 1/8	1	2 1/8	4 1/4
2 1/4	1	3 1/4	5 1/4	2 1/4	1	2 1/4	4 1/2
2 1/2	1	3 1/2	5 1/2	2 1/2	1	2 1/2	4 3/4
2 3/4	1 1/4	3 3/4	5 3/4	2 3/4	1 1/4	2 3/4	5
3	1 1/4	4	6	3	1 1/4	3	5 1/2

All dimensions are in inches. All cutters are high-speed steel. Right-hand cutters with right-hand helix are standard. Helix angle is greater than 19 degrees but not more than 39 degrees.

Tolerances: On C and D, -0.0015 inch for stub-length mills, +0.003 inch for regular-length mills; on S, -0.0001 to -0.0005 inch; on W, ± 1/32 inch; and on L, ± 1/32 inch.

The following single-end end mills are available in premium high speed steel: ball end, two flute, with D ranging from 1/8 to 1 1/2 inches; ball end, multiple flute, with D ranging from 1/8 to 1 inch; and plain end, two flute, with D ranging from 1/8 to 1 1/2 inches.

**American National Standard Long-Length Single-End and Stub-, and Regular Length, Double-End, Plain- and Ball-End, Medium Helix, Two-Flute End Mills with Weldon Shanks ANS/ASME B94.19-1997**

Single End								
Dia., C and D	Long Length — Plain End				Long Length — Ball End			
	S	B*	W	L	S	B*	W	L
1/8	...	...	...	...	3/8	1 1/16	3/8	2 3/8
3/16	...	...	...	...	3/8	1 1/2	1/2	2 1/2
1/4	3/8	1 1/2	3/8	3 1/16	3/8	1 1/2	3/8	3 1/16
5/16	3/4	1 3/4	3/4	3 5/16	3/8	1 3/4	3/8	3 5/16
3/8	3/8	1 3/4	3/4	3 5/16	3/8	1 3/4	3/8	3 5/16
7/16	...	...	...	...	1/2	1 3/4	1	3 1/2
1/2	1/2	2 3/8	1	4	1/2	2 1/4	1	4
9/16	3/8	2 3/8	1 3/8	4 3/8	3/8	2 1/4	1 3/8	4 3/8
5/8	3/4	3 1/4	1 3/8	5 3/8	3/8	3 1/4	1 3/8	5 3/8
1	1	4 3/8	2 1/2	7 1/4	1	5	2 1/2	7 1/4
1 1/4	1 1/2	4 3/8	3	7 1/4	...	...	...	...

\*B is the length below the shank.

Dia., C and D	Double End								
	Stub Length — Plain End			Regular Length — Plain End			Regular Length — Ball End		
	S	W	L	S	W	L	S	W	L
1/8	3/8	3/8	2 1/2	3/8	3/8	3 1/8	3/8	3/8	3 1/8
3/16	3/8	3/8	2 1/2	3/8	3/8	3 1/8	...	...	...
1/4	3/8	3/8	2 1/2	3/8	3/8	3 1/8	3/8	3/8	3 1/8
5/16	3/8	3/8	2 3/8	3/8	3/8	3 1/8	...	...	...
3/8	3/8	3/8	2 3/8	3/8	3/8	3 1/8	3/8	3/8	3 1/8
7/16	...	...	...	3/8	3/8	3 1/8	...	...	...
1/2	...	...	...	3/8	3/8	3 1/8	3/8	3/8	3 1/8
9/16	...	...	...	3/8	3/8	3 1/8	...	...	...
5/8	...	...	...	3/8	3/8	3 1/8	3/8	3/8	3 1/8
3/4	...	...	...	3/8	3/8	3 1/8	...	...	...
7/8	...	...	...	3/8	3/8	3 1/8	3/8	3/8	3 1/8
1	...	...	...	3/8	3/8	3 1/8	...	...	...
1 1/8	...	...	...	3/8	3/8	3 1/8	3/8	3/8	3 1/8
1 1/4	...	...	...	3/8	3/8	3 1/8	...	...	...
1 1/2	...	...	...	3/8	3/8	3 1/8	3/8	3/8	3 1/8
1 3/4	...	...	...	3/8	3/8	3 1/8	...	...	...
2	...	...	...	3/8	3/8	3 1/8	3/8	3/8	3 1/8
2 1/4	...	...	...	3/8	3/8	3 1/8	...	...	...
2 1/2	...	...	...	3/8	3/8	3 1/8	3/8	3/8	3 1/8
2 3/4	...	...	...	3/8	3/8	3 1/8	...	...	...
3	...	...	...	3/8	3/8	3 1/8	3/8	3/8	3 1/8
3 1/4	...	...	...	3/8	3/8	3 1/8	...	...	...
3 1/2	...	...	...	3/8	3/8	3 1/8	3/8	3/8	3 1/8
3 3/4	...	...	...	3/8	3/8	3 1/8	...	...	...
4	...	...	...	3/8	3/8	3 1/8	3/8	3/8	3 1/8
4 1/4	...	...	...	3/8	3/8	3 1/8	...	...	...
4 1/2	...	...	...	3/8	3/8	3 1/8	3/8	3/8	3 1/8
4 3/4	...	...	...	3/8	3/8	3 1/8	...	...	...
5	...	...	...	3/8	3/8	3 1/8	3/8	3/8	3 1/8
5 1/4	...	...	...	3/8	3/8	3 1/8	...	...	...
5 1/2	...	...	...	3/8	3/8	3 1/8	3/8	3/8	3 1/8
5 3/4	...	...	...	3/8	3/8	3 1/8	...	...	...
6	...	...	...	3/8	3/8	3 1/8	3/8	3/8	3 1/8

All dimensions are in inches. All cutters are high-speed steel. Right-hand cutters with right-hand helix are standard. Helix angle is greater than 19 degrees but not more than 39 degrees.  
 Tolerances: On C and D, +0.003 inch for single-end mills, -0.0015 inch for double-end mills; on S, -0.0001 to -0.0005 inch; on W, ±1/32 inch; and on L, ±1/16 inch.

American National Standard Regular-, Long-, and Extra Long-Length, Three- and Four-Flute, Medium Helix, Center Cutting, Single-End End Mills with Weldon Shanks ANSI/ASME B94.19-1997

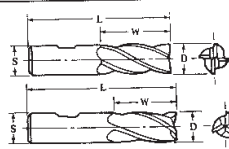

Four Flute									
Dia., D	Regular Length			Long Length			Extra Long Length		
	S	W	L	S	W	L	S	W	L
1/8	3/8	3/8	2 3/8	...	...	...	...	...	...
3/16	3/8	3/8	2 3/8	...	...	...	...	...	...
1/4	3/8	3/8	2 3/8	3/8	1 1/2	3 3/8	3/8	1 1/2	3 3/8
5/16	3/8	3/8	2 3/8	3/8	1 3/4	3 3/8	3/8	2	4 1/4
3/8	3/8	3/8	2 3/8	3/8	1 3/4	3 3/8	3/8	2 1/2	4 1/4
1/2	3/8	3/8	2 3/8	3/8	2	4	3/8	3	5
5/8	3/8	3/8	2 3/8	3/8	2 1/2	4 3/8	3/8	4	6 1/4
3/4	3/8	3/8	2 3/8	3/8	3	5 1/8	3/8	4	6 1/4
7/8	3/8	3/8	2 3/8	3/8	3 1/2	5 3/8	3/8	4	6 1/4
1	3/8	3/8	2 3/8	3/8	4	6 1/8	3/8	4	6 1/4
1 1/8	1	1	4 1/2	1	...	...	...	...	...
1 1/4	1	1	4 1/2	1 1/4	...	...	...	...	...
1 1/2	1 1/4	1 1/4	4 1/2	...	...	...	...	...	...

Three Flute									
Dia., D	Regular Length			Dia., D	Regular Length (cont.)				
	S	W	L		S	W	L		
1/8	3/8	3/8	2 3/8	1 1/4	1	2	4 1/2		
3/16	3/8	3/8	2 3/8	1 1/4	1	2	4 1/2		
1/4	3/8	3/8	2 3/8	1 1/4	1	2	4 1/2		
5/16	3/8	3/8	2 3/8	1 1/4	1 1/2	2	4 1/2		
3/8	3/8	3/8	2 3/8	1 1/4	1 1/2	2	4 1/2		
1/2	3/8	3/8	2 3/8	1 1/4	1 1/2	2	4 1/2		
5/8	3/8	3/8	2 3/8	1 1/4	1 1/2	2	4 1/2		
3/4	3/8	3/8	2 3/8	1 1/4	1 1/2	2	4 1/2		
7/8	3/8	3/8	2 3/8	1 1/4	1 1/2	2	4 1/2		
1	3/8	3/8	2 3/8	1 1/4	1 1/2	2	4 1/2		
1 1/8	1	1	4 1/2	1 1/4	1 1/2	2	4 1/2		
1 1/4	1	1	4 1/2	1 1/4	1 1/2	2	4 1/2		
1 1/2	1 1/4	1 1/4	4 1/2	1 1/4	1 1/2	2	4 1/2		

Long Length						
Dia., D	S	W	L	Dia., D	S	W
3/8	3/8	3/8	3 3/8	3/8	3/8	1 1/2
1/2	3/8	3/8	3 3/8	1/2	3/8	1 1/2
5/8	3/8	3/8	3 3/8	5/8	3/8	1 1/2
3/4	3/8	3/8	3 3/8	3/4	3/8	1 1/2
7/8	3/8	3/8	3 3/8	7/8	3/8	1 1/2
1	3/8	3/8	3 3/8	1	3/8	1 1/2
1 1/8	3/8	3/8	3 3/8	1 1/8	3/8	1 1/2
1 1/4	3/8	3/8	3 3/8	1 1/4	3/8	1 1/2
1 1/2	3/8	3/8	3 3/8	1 1/2	3/8	1 1/2

All dimensions are in inches. All cutters are high-speed steel. Right-hand cutters with right-hand helix are standard. Helix angle is greater than 19 degrees but not more than 39 degrees.  
 Tolerances: On D, +0.003 inch; on S, -0.0001 to -0.0005 inch; on W, ±1/64 inch; and on L, ±1/64 inch.  
 The following center-cutting, single-end mills are available in premium high speed steel: regular length, multiple flute, with D ranging from 1/8 to 1 1/2 inches; long length, multiple flute, with D ranging from 3/8 to 1 1/4 inches; and extra long-length, multiple flute, with D ranging from 3/8 to 1 1/2 inches.

**American National Standard Stub- and Regular-length, Four-flute, Medium Helix, Double-end End Mills with Weldon Shanks ANS/ASME B94.19-1997**

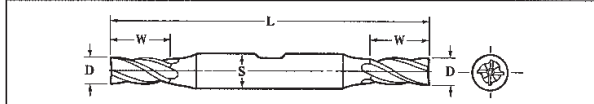

Stub Length				Regular Length			
Dia., D	S	W	L	Dia., D	S	W	L
1/8	3/16	3/16	2 3/4	1/8	3/16	3/16	3 1/2
3/16	3/8	3/8	2 3/4	3/16	3/8	3/8	3 1/2
1/4	1/2	1/2	3 1/4	1/4	1/2	1/2	4 1/4
5/16	5/8	5/8	3 1/4	5/16	5/8	5/8	4 1/4
3/8	3/4	3/4	3 1/2	3/8	3/4	3/4	4 1/2
1/2	1	1	3 1/2	1/2	1	1	5
5/8	1 1/8	1 1/8	3 1/2	5/8	1 1/8	1 1/8	5
3/4	1 1/4	1 1/4	3 1/2	3/4	1 1/4	1 1/4	5
7/8	1 5/8	1 5/8	3 1/2	7/8	1 5/8	1 5/8	5
1	2	2	3 1/2	1	2	2	5

<sup>a</sup>In this size of regular mill a left-hand cutter with a left-hand helix is also standard.  
 All dimensions are in inches. All cutters are high-speed steel. Right-hand cutters with right-hand helix are standard. Helix angle is greater than 19 degrees but not more than 39 degrees.  
 Tolerances: On D, +0.003 inch (if the shank is the same diameter as the cutting portion, however, then the tolerance on the cutting diameter is -0.0025 inch); on S, -0.0001 to -0.0005 inch; on W, ±1/32 inch; and on L, ±1/16 inch.

**American National Standard Stub- and Regular-length, Four-Flute, Medium Helix, Double-End End Mills with Weldon Shanks ANS/ASME B94.19-1997**

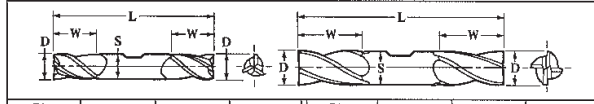

Three Flute				Four Flute			
Dia., D	S	W	L	Dia., D	S	W	L
1/8	3/16	3/16	3 1/4	1/8	3/16	3/16	3 1/4
3/16	3/8	3/8	3 1/4	3/16	3/8	3/8	3 1/4
1/4	1/2	1/2	3 1/2	1/4	1/2	1/2	3 1/2
5/16	5/8	5/8	3 1/2	5/16	5/8	5/8	3 1/2
3/8	3/4	3/4	3 1/2	3/8	3/4	3/4	3 1/2
1/2	1	1	4 1/4	1/2	1	1	4 1/4
5/8	1 1/8	1 1/8	4 1/4	5/8	1 1/8	1 1/8	4 1/4
3/4	1 1/4	1 1/4	4 1/4	3/4	1 1/4	1 1/4	4 1/4
7/8	1 5/8	1 5/8	4 1/4	7/8	1 5/8	1 5/8	4 1/4
1	2	2	4 1/4	1	2	2	4 1/4

All dimensions are in inches. All cutters are high-speed steel. Right-hand cutters with right-hand helix are standard. Helix angle is greater than 19 degrees but not more than 39 degrees.  
 Tolerances: On D, +0.0015 inch; on S, -0.0001 to -0.0005 inch; on W, ±1/32 inch; and on L, ±1/16 inch.

**American National Standard Plain- and Ball-End, Heavy Duty, Medium Helix, Single-End End Mills with 2-Inch Diameter Shanks ANS/ASME B94.19-1997**

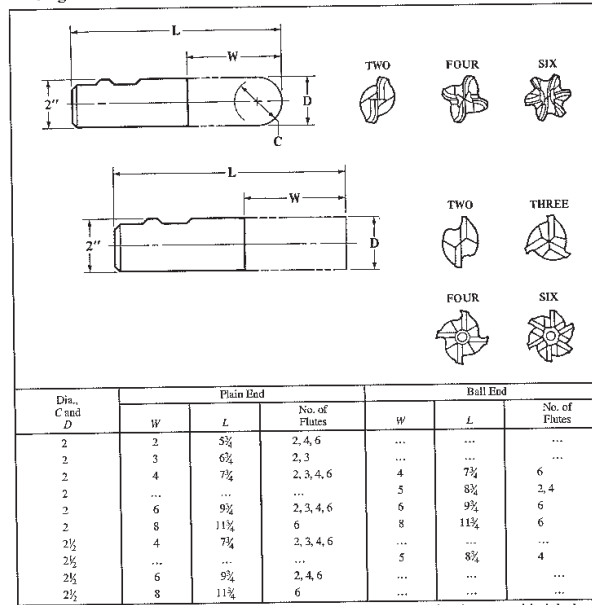

Dia., C and D	Plain End			Ball End		
	W	L	No. of Flutes	W	L	No. of Flutes
2	2	5 1/4	2, 4, 6	...	...	...
2	3	6 1/4	2, 3	...	...	...
2	4	7 1/4	2, 3, 4, 6	4	7 3/4	6
2	...	...	...	5	8 1/4	2, 4
2	6	9 1/4	2, 3, 4, 6	6	9 3/4	6
2	8	11 1/4	6	8	11 3/4	6
2 1/2	4	7 3/4	2, 3, 4, 6	...	...	...
2 1/2	...	...	...	5	8 1/4	4
2 1/2	6	9 3/4	2, 4, 6	...	...	...
2 1/2	8	11 3/4	6	...	...	...

All dimensions are in inches. All cutters are high-speed steel. Right-hand cutters with right-hand helix are standard. Helix angle is greater than 19 degrees but not more than 39 degrees.  
 Tolerances: On C and D, +0.005 inch for 2, 3, 4 and 6 flutes; on W, ± 1/64 inch; and on L, ± 1/64 inch.

**Dimensions of American National Standard Weldon Shanks ANS/ASME B94.19-1997**

Shank		Flat		Shank		Flat	
Dia.	Length	X <sup>a</sup>	Length <sup>b</sup>	Dia.	Length	X <sup>a</sup>	Length <sup>b</sup>
1/8	1 1/8	0.325	0.280	1	2 7/8	0.925	0.515
1/4	1 5/8	0.440	0.330	1 1/4	2 7/8	1.156	0.515
3/8	1 7/8	0.560	0.400	1 1/2	2 7/8	1.406	0.515
1/2	2 1/8	0.675	0.455	2	3 1/4	1.900	0.700
5/8	2 1/2	0.810	0.455	2 1/2	3 1/2	2.400	0.700

<sup>a</sup>X is distance from bottom of flat to opposite side of shank.  
<sup>b</sup>Minimum.

All dimensions are in inches.  
 Centerline of flat is at half-length of shank except for 1 1/2-, 2- and 2 1/2-inch shanks where it is 1 3/16-, 1 7/16- and 1 1/2- from shank end, respectively.  
 Tolerance on shank diameter, -0.0001 to -0.0005 inch.



American National Standard Form Relieved, Concave, Convex, and Corner-Rounding Arbor-Type Cutters ANS/ASME B94.19-1997

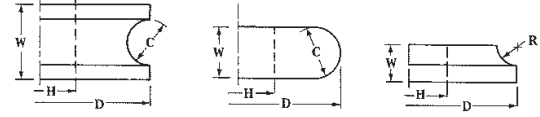

Diameter C or Radius R			Cutter Dia. D <sup>a</sup>	Width W ±.010 <sup>b</sup>	Diameter of Hole H		
Num.	Max.	Min.			Num.	Max.	Min.
Concave Cutters <sup>c</sup>							
1/4	0.1270	0.1240	2 1/2	1/4	1	1.00075	1.00000
3/16	0.1895	0.1865	2 1/2	3/16	1	1.00075	1.00000
1/2	0.2520	0.2490	2 1/2	1/4	1	1.00075	1.00000
5/16	0.3145	0.3115	2 3/4	3/16	1	1.00075	1.00000
3/8	0.3770	0.3740	2 3/4	1/4	1	1.00075	1.00000
7/16	0.4395	0.4365	3	3/8	1	1.00075	1.00000
1/2	0.5040	0.4980	3	1/2	1	1.00075	1.00000
9/16	0.6290	0.6230	3 1/2	1	1 1/2	1.251	1.250
5/8	0.7540	0.7480	3 1/2	1 1/2	1 1/2	1.251	1.250
3/4	0.8790	0.8730	4	1 3/4	1 1/2	1.251	1.250
1	1.0040	0.9980	4 1/2	1 3/4	1 1/2	1.251	1.250
Convex Cutters <sup>d</sup>							
1/4	0.1270	0.1230	2 1/2	1/4	1	1.00075	1.00000
3/16	0.1895	0.1855	2 1/2	3/16	1	1.00075	1.00000
1/2	0.2520	0.2480	2 1/2	1/4	1	1.00075	1.00000
5/16	0.3145	0.3105	2 3/4	3/16	1	1.00075	1.00000
3/8	0.3770	0.3730	2 3/4	1/4	1	1.00075	1.00000
7/16	0.4395	0.4355	3	3/8	1	1.00075	1.00000
1/2	0.5020	0.4980	3	1/2	1	1.00075	1.00000
9/16	0.6270	0.6230	3 1/2	3/4	1 1/2	1.251	1.250
5/8	0.7520	0.7480	3 1/2	1/2	1 1/2	1.251	1.250
3/4	0.8770	0.8730	4	3/4	1 1/2	1.251	1.250
1	1.0020	0.9980	4 1/2	1	1 1/2	1.251	1.250
Corner-rounding Cutters <sup>d</sup>							
1/4	0.1260	0.1240	2 1/2	1/4	1	1.00075	1.00000
1/2	0.2520	0.2490	3	1/2	1	1.00075	1.00000
3/8	0.3770	0.3740	3 1/2	3/8	1 1/2	1.251	1.250
1/2	0.5020	0.4990	4 1/2	1/2	1 1/2	1.251	1.250
3/4	0.6270	0.6240	4 1/2	3/4	1 1/2	1.251	1.250

<sup>a</sup>Tolerances on cutter diameter are + 1/16, - 1/16 inch for all sizes.

<sup>b</sup>Tolerance does not apply to convex cutters.

<sup>c</sup>Size of cutter is designated by specifying diameter C of circular form.

<sup>d</sup>Size of cutter is designated by specifying radius R of circular form.

All dimensions in inches. All cutters are high-speed steel and are form relieved. Right-hand corner rounding cutters are standard, but left-hand cutter for 1/2-inch size is also standard.

For key and keyway dimensions for these cutters, see page 794.

American National Standard Roughing and Finishing Gear Milling Cutters for Gears with 14½-Degree Pressure Angles ANSI/ASME B94.19-1997

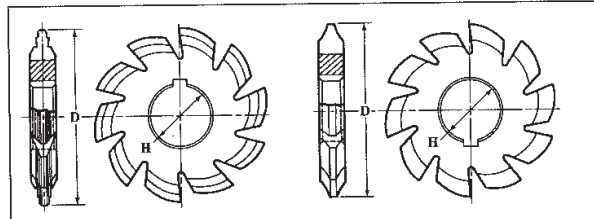

ROUGHING			FINISHING		
Diametral Pitch	Dia. of Cutter, D	Dia. of Hole, H	Diametral Pitch	Dia. of Cutter, D	Dia. of Hole, H
Roughing Gear Milling Cutters					
1	8½	2	3	3¼	1½
1½	7¾	2	3	4¾	1¾
1½	7	1¾	4	4¾	1¾
1½	6½	1¾	4	4¾	1¾
2	6½	1¾	4	4¾	1¾
2	5¾	1½	4	3¾	1
2½	6¾	1¾	5	4¾	1¾
2½	5¾	1½	5	4¾	1¾
3	5¾	1½	5	3¾	1¾
Finishing Gear Milling Cutters					
1	8½	2	6	3¾	1½
1½	7¾	2	6	3¾	1¾
1½	7	1¾	6	3¾	1
1½	6½	1¾	7	3¾	1¾
2	6½	1¾	7	3¾	1¾
2	5¾	1¾	7	2¾	1
2½	6¾	1¾	8	3¾	1¾
2½	5¾	1¾	8	3¾	1¾
3	5¾	1¾	8	2¾	1
3	5¾	1¾	9	3¾	1¾
3	4¾	1¾	9	2¾	1
4	4¾	1¾	10	3	1¾
4	4¾	1½	10	2¾	1
4	4¾	1¾	10	2¾	¾
4	3¾	1	11	2¾	1
5	4¾	1¾	11	2¾	¾
5	4¾	1¾	12	2¾	1¾
5	3¾	1¾	12	2¾	1
5	3¾	1	12	2¾	¾
6	4¾	1¾	14	2¾	1

All dimensions are in inches.  
 All gear milling cutters are high-speed steel and are form relieved.  
 For keyway dimensions see page 794.  
 Tolerances: On outside diameter, + $\frac{1}{64}$ , - $\frac{1}{64}$  inch; on hole diameter, through 1-inch hole diameter, -0.00075 inch, over 1-inch and through 2-inch hole diameter, +0.0010 inch.  
 For cutter number relative to numbers of gear teeth, see page 2021. Roughing cutters are made with No. 1 cutter form only.

**American National Standard Gear Milling Cutters for Mitre and Bevel Gears with 14½-Degree Pressure Angles ANS/ASME B94.19-1997**

Diametral Pitch	Diameter of Cutter, D	Diameter of Hole, H	Diametral Pitch	Diameter of Cutter, D	Diameter of Hole, H
3	4	1½	10	2¾	¾
4	3¾	1½	12	2¾	¾
5	3¾	1¼	14	2¾	¾
6	3¼	1	16	2¾	¾
7	2¾	1	20	2	¾
8	2¾	1	24	1¾	¾

All dimensions are in inches.

All cutters are high-speed steel and are form relieved.

For keyway dimensions see page 794. For cutter selection see page 2060.

**Tolerances:** On outside diameter, + $\frac{1}{16}$ , - $\frac{1}{16}$  inch; on hole diameter, through 1-inch hole diameter, +0.00075 inch, for 1¼-inch hole diameter, +0.0010 inch.

To select the cutter number for bevel gears with the axis at any angle, double the back cone radius and multiply the result by the diametral pitch. This procedure gives the number of equivalent spur gear teeth and is the basis for selecting the cutter number from the table on page 2023.

**American National Standard Roller Chain Sprocket Milling Cutters ANS/ASME B94.19-1997**

Chain Pitch	Dia. of Roll	No. of Teeth in Sprocket	Dia. of Cutter, D	Width of Cutter, W	Dia. of Hole, H
¼	0.130	6	2¾	¾	1
¼	0.130	7-8	2¾	¾	1
¼	0.130	9-11	2¾	¾	1
¼	0.130	12-17	2¾	¾	1
¼	0.130	18-34	2¾	¾	1
¼	0.130	35 and over	2¾	¾	1
⅜	0.200	6	2¾	1½	1
⅜	0.200	7-8	2¾	1½	1
⅜	0.200	9-11	2¾	1½	1
⅜	0.200	12-17	2¾	1½	1
⅜	0.200	18-34	2¾	1½	1
⅜	0.200	35 and over	2¾	1½	1
½	0.313	6	3	¾	1
½	0.313	7-8	3	¾	1
½	0.313	9-11	3¾	¾	1
½	0.313	12-17	3¾	¾	1
½	0.313	18-34	3¾	¾	1
½	0.313	35 and over	3¾	¾	1
⅝	0.400	6	3¾	¾	1
⅝	0.400	7-8	3¾	¾	1
⅝	0.400	9-11	3¾	¾	1
⅝	0.400	12-17	3¾	¾	1

American National Standard Roller Chain Sprocket  
Milling Cutters *ANSI/ASME B94.19-1997*

Chordal Pitch	Dia. of Roll	No. of Teeth in Sprocket	Dia. of Cutter, <i>D</i>	Width of Cutter, <i>D</i>	Dia. of Hole, <i>H</i>
3/8	0.400	18-34	3 1/2	2 1/4	1
3/8	0.400	35 and over	3 1/2	3 1/4	1
3/8	0.469	6	3 1/2	2 1/4	1
3/8	0.469	7-8	3 1/2	2 1/4	1
3/8	0.469	9-11	3 1/2	2 1/4	1
3/8	0.469	12-17	3 1/2	2 1/4	1
3/8	0.469	18-34	3 1/2	2 1/4	1
3/8	0.469	35 and over	3 1/2	3 1/4	1
1	0.625	6	3 1/2	1 1/2	1 1/4
1	0.625	7-8	4	1 1/2	1 1/4
1	0.625	9-11	4 1/2	1 1/2	1 1/4
1	0.625	18-34	4 1/2	1 1/2	1 1/4
1	0.625	35 and over	4 1/2	1 1/2	1 1/4
1 1/8	0.750	6	4 1/2	1 1/2	1 1/4
1 1/8	0.750	7-8	4 1/2	1 1/2	1 1/4
1 1/8	0.750	9-11	4 1/2	1 1/2	1 1/4
1 1/8	0.750	18-34	4 1/2	1 1/2	1 1/4
1 1/8	0.750	35 and over	4 1/2	1 1/2	1 1/4
1 1/8	0.875	6	4 1/2	1 1/2	1 1/4
1 1/8	0.875	7-8	4 1/2	1 1/2	1 1/4
1 1/8	0.875	9-11	4 1/2	1 1/2	1 1/4
1 1/8	0.875	12-17	4 1/2	1 1/2	1 1/4
1 1/8	0.875	18-34	4 1/2	1 1/2	1 1/4
1 1/8	0.875	35 and over	4 1/2	1 1/2	1 1/4
1 1/2	1.000	6	5	2 1/2	1 1/2
1 1/2	1.000	7-8	5 1/2	2 1/2	1 1/2
1 1/2	1.000	9-11	5 1/2	2 1/2	1 1/2
1 1/2	1.000	12-17	5 1/2	2 1/2	1 1/2
1 1/2	1.000	18-34	5 1/2	2 1/2	1 1/2
1 1/2	1.000	35 and over	5 1/2	2 1/2	1 1/2
2	1.125	6	5 1/2	2 1/2	1 1/2
2	1.125	7-8	5 1/2	2 1/2	1 1/2
2	1.125	9-11	5 1/2	2 1/2	1 1/2
2	1.125	12-17	5 1/2	2 1/2	1 1/2
2	1.125	18-34	5 1/2	2 1/2	1 1/2
2	1.125	35 and over	5 1/2	2 1/2	1 1/2
2 1/4	1.406	6	5 1/2	2 1/2	1 1/2
2 1/4	1.406	7-8	6	2 1/2	1 1/2
2 1/4	1.406	9-11	6 1/2	2 1/2	1 1/2
2 1/4	1.406	12-17	6 1/2	2 1/2	1 1/2
2 1/4	1.406	18-34	6 1/2	2 1/2	1 1/2
2 1/4	1.406	35 and over	6 1/2	2 1/2	1 1/2
2 1/2	1.563	6	6 1/2	3	1 3/4
2 1/2	1.563	7-8	6 1/2	3	1 3/4
2 1/2	1.563	9-11	6 1/2	2 1/2	1 3/4
2 1/2	1.563	12-17	6 1/2	2 1/2	1 3/4
2 1/2	1.563	18-34	7	2 1/2	1 3/4
2 1/2	1.563	35 and over	7 1/2	2 1/2	1 3/4
3	1.875	6	7 1/2	3 1/2	2
3	1.875	7-8	7 1/2	3 1/2	2
3	1.875	9-11	7 1/2	3 1/2	2
3	1.875	12-17	8	3 1/2	2
3	1.875	18-34	8	3 1/2	2
3	1.875	35 and over	8 1/2	3 1/2	2

All dimensions are in inches.

All cutters are high-speed steel and are form relieved.

For keyway dimensions see page 794.

Tolerances: Outside diameter, +1/16, -1/16 inch; hole diameter, through 1-inch diameter, +0.00075 inch, above 1-inch diameter and through 2-inch diameter, +0.0010 inch.

For tooth form, see ANSI sprocket tooth form table on page 2438.

American National Standard Keys and Keyways for Milling Cutters and Arbors ANSI/ASME B94.19-1997

Non-Arbor and Cutter Hole Dia.	Non-Arbor Size Key (Square)		Arbor and Keyseat		CUTTER HOLE AND KEYWAY		Arbor and Key		ARBOR AND KEY	
	A	B	A	B	C	H	C	H	E	F
1/2	0.0947	0.4531	0.099	0.4481	0.106	0.578	0.109	0.578	0.0932	0.3468
3/8	0.1260	0.5225	0.137	0.5175	0.137	0.6985	0.130	0.6985	0.1240	0.6815
1/4	0.1260	0.4875	0.137	0.4875	0.137	0.6225	0.130	0.6225	0.1240	0.6055
3/16	0.1260	0.4530	0.137	0.4530	0.137	0.5475	0.130	0.5475	0.1240	0.5315
1	0.2510	0.8438	0.252	0.8388	0.252	1.040	0.255	1.040	0.2495	0.9945
1 1/2	0.3135	1.0630	0.318	1.0580	0.318	1.380	0.318	1.380	0.3120	1.3750
2	0.3760	1.2810	0.385	1.2760	0.385	1.660	0.385	1.660	0.3740	1.6500
2 1/2	0.4385	1.5000	0.448	1.4950	0.448	1.940	0.448	1.940	0.4370	1.9300
3	0.5010	1.6820	0.510	1.6820	0.510	2.190	0.510	2.190	0.4995	2.1800
3 1/2	0.5635	1.8640	0.575	1.8640	0.575	2.440	0.575	2.440	0.5640	2.4300
4	0.6260	2.0460	0.635	2.0460	0.635	2.690	0.635	2.690	0.6255	2.6800
4 1/2	0.6885	2.2280	0.698	2.2280	0.698	2.940	0.698	2.940	0.6895	2.9300
5	0.7510	2.4100	0.760	2.4100	0.760	3.190	0.760	3.190	0.7515	3.1800
5 1/2	0.8135	2.5920	0.823	2.5920	0.823	3.440	0.823	3.440	0.8145	3.4300
6	0.8760	2.7740	0.885	2.7740	0.885	3.690	0.885	3.690	0.8765	3.6800
6 1/2	0.9385	2.9560	0.948	2.9560	0.948	3.940	0.948	3.940	0.9395	3.9300
7	1.0010	3.1380	1.010	3.1380	1.010	4.190	1.010	4.190	1.0015	4.1800
7 1/2	1.0635	3.3200	1.073	3.3200	1.073	4.440	1.073	4.440	1.0645	4.4300
8	1.1260	3.5020	1.135	3.5020	1.135	4.690	1.135	4.690	1.1265	4.6800
8 1/2	1.1885	3.6840	1.198	3.6840	1.198	4.940	1.198	4.940	1.1895	4.9300
9	1.2510	3.8660	1.260	3.8660	1.260	5.190	1.260	5.190	1.2515	5.1800

\* D max. is 0.010 inch larger than D min.  
All dimensions given in inches.

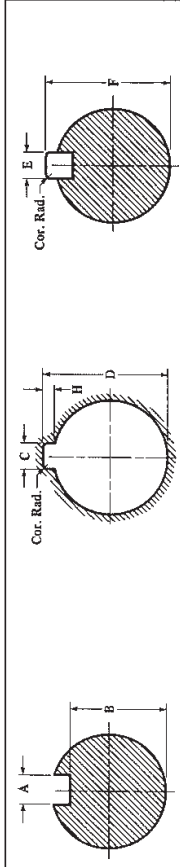

American National Standard Woodruff Keyseat Cutters—Shank-Type Straight-Teeth and Arbor-Type Staggered-Teeth ANSIA/SME B94.19-1997

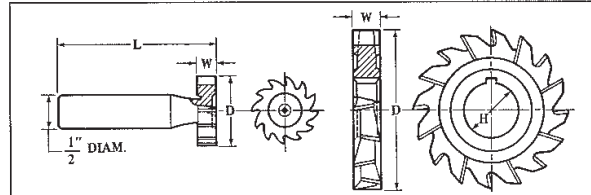

Shank-type Cutters											
Cutter Number	Nom. Dia. of Cutter, D	Width of Face, W	Length Over-all, L	Cutter Number	Nom. Dia. of Cutter, D	Width of Face, W	Length Over-all, L	Cutter Number	Nom. Dia. of Cutter, D	Width of Face, W	Length Over-all, L
202	1/2	1/16	2 1/2	506	3/4	3/16	2 3/4	809	1 1/4	1/4	2 3/4
202 1/2	5/16	1/16	2 1/2	606	3/4	3/16	2 3/4	1009	1 1/4	3/16	2 3/4
302 1/2	5/16	3/32	2 3/4	806	3/4	1/4	2 1/4	610	1 1/4	3/16	2 3/4
203	3/8	1/16	2 1/2	507	3/8	3/32	2 3/4	710	1 1/4	1/32	2 7/8
303	3/8	3/32	2 3/4	607	3/8	3/16	2 3/4	810	1 1/4	1/4	2 1/4
403	3/8	1/8	2 1/2	707	3/8	1/32	2 3/4	1010	1 1/4	3/16	2 3/4
204	1/2	1/16	2 1/2	807	3/4	1/4	2 1/4	1210	1 1/4	3/8	2 3/4
304	1/2	3/32	2 3/4	608	1	3/16	2 3/4	811	1 1/4	1/4	2 1/4
404	1/2	1/8	2 1/2	708	1	1/32	2 3/4	1011	1 1/4	3/16	2 3/4
305	3/4	3/32	2 3/4	808	1	1/4	2 1/4	1211	1 1/4	3/8	2 3/4
405	3/4	1/8	2 1/2	1008	1	3/16	2 3/4	812	1 1/4	1/4	2 1/4
505	3/4	5/32	2 3/4	1208	1	3/8	2 3/4	1012	1 1/4	3/16	2 3/4
605	3/4	3/16	2 3/4	609	1 1/4	3/16	2 3/4	1212	1 1/2	3/8	2 3/4
406	3/4	1/8	2 1/2	709	1 1/4	1/4	2 1/4	...	...	...	...

  

Arbor-type Cutters											
Cutter Number	Nom. Dia. of Cutter, D	Width of Face, W	Dia. of Hole, H	Cutter Number	Nom. Dia. of Cutter, D	Width of Face, W	Dia. of Hole, H	Cutter Number	Nom. Dia. of Cutter, D	Width of Face, W	Dia. of Hole, H
617	2 1/2	3/16	3/4	1022	2 3/4	3/16	1	1628	3 1/2	1/2	1
817	2 1/2	1/4	3/4	1222	2 3/4	3/8	1	1828	3 1/2	3/16	1
1017	2 1/2	3/8	1/2	1422	2 3/4	3/16	1	2028	3 1/2	3/8	1
1217	2 1/2	1/2	1/2	1622	2 3/4	1/2	1	2428	3 1/2	3/4	1
822	2 3/4	1/4	1	1228	3 1/2	3/8	1	...	...	...	...

All dimensions are given in inches. All cutters are high-speed steel. Shank type cutters are standard with right-hand cut and straight teeth. All sizes have 1/2-inch diameter straight shank.

Arbor type cutters have staggered teeth. For Woodruff key and key-slot dimensions, see pages 2348 through 2350. Tolerances: Face with W for shank type cutters: 1/16- to 3/32-inch face, +0.0000, -0.0005; 3/16 to 3/32, -0.0002, -0.0007; 1/4, -0.0003, -0.0008; 3/16, -0.0004, -0.0009; 3/8, -0.0005, -0.0010 inch. Face width W for arbor type cutters; 3/16 inch face, -0.0002, -0.0007; 1/4, -0.0003, -0.0008; 3/16, -0.0004, -0.0009; 3/8 and over, -0.0005, -0.0010 inch. Hole size H: ±0.00075, -0.0000 inch. Diameter D for shank type cutters: 1/4- through 3/4-inch diameter, +0.010, +0.015, 3/8 through 1 1/8, +0.012, +0.017; 1 1/4 through 1 1/2, +0.015, +0.020 inch. These tolerances include an allowance for sharpening. For arbor type cutters diameter D is furnished 1/32 inch larger than listed and a tolerance of ±0.002 inch applies to the oversize diameter.

**Setting Angles for Milling Straight Teeth of Uniform Land Width in End Mills, Angular Cutters, and Taper Reamers.**—The accompanying tables give setting angles for the dividing head when straight teeth, having a land of uniform width throughout their length, are to be milled using single-angle fluting cutters. These setting angles depend upon three factors: the number of teeth to be cut; the angle of the blank in which the teeth are to be cut; and the angle of the fluting cutter. Setting angles for various combinations of these three factors are given in the tables. For example, assume that 12 teeth are to be cut on the end of an end mill using a 60-degree cutter. By following the horizontal line from 12 teeth, read in the column under 60 degrees that the dividing head should be set to an angle of 70 degrees and 32 minutes.

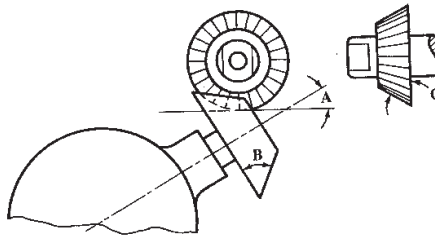

The following formulas, which were used to compile these tables, may be used to calculate the setting-angles for combinations of number of teeth, blank angle, and cutter angle not covered by the tables. In these formulas,  $A$  = setting-angle for dividing head,  $B$  = angle of blank in which teeth are to be cut,  $C$  = angle of fluting cutter,  $N$  = number of teeth to be cut, and  $D$  and  $E$  are angles not shown on the accompanying diagram and which are used only to simplify calculations.

$$\tan D = \cos(360^\circ/N) \times \cot B \quad (1)$$

$$\sin E = \tan(360^\circ/N) \times \cot C \times \sin D \quad (2)$$

$$\text{Setting-angle } A = D - E \quad (3)$$

*Example:* Suppose 9 teeth are to be cut in a 35-degree blank using a 55-degree single-angle fluting cutter. Then,  $N = 9$ ,  $B = 35^\circ$ , and  $C = 55^\circ$ .

$$\tan D = \cos(360^\circ/9) \times \cot 35^\circ = 0.76604 \times 1.4281 = 1.0940; \text{ and } D = 47^\circ 34'$$

$$\sin E = \tan(360^\circ/9) \times \cot 55^\circ \times \sin 47^\circ 34' = 0.83910 \times 0.70021 \times 0.73806 \\ = 0.43365; \text{ and } E = 25^\circ 42'$$

$$\text{Setting angle } A = 47^\circ 34' - 25^\circ 42' = 21^\circ 52'$$

For end mills and side mills the angle of the blank  $B$  is 0 degrees and the following simplified formula may be used to find the setting angle  $A$

$$\cos A = \tan(360^\circ/N) \times \cot C \quad (4)$$

*Example:* If in the previous example the blank angle was 0 degrees,

$$\cos A = \tan(360^\circ/9) \times \cot 55^\circ$$

$$= 0.83910 \times 0.70021 = 0.58755; \text{ and setting-angle } A = 54^\circ 1'$$

Angles of Elevation for Milling Straight Teeth in 0-, 5-, 10-, 15-, 20-, 25-, 30-, and 35-degree Blanks Using Single-Angle Fluting Cutters

No. of Teeth	Angle of Fluting Cutter									
	90°	80°	70°	60°	50°	90°	80°	70°	60°	50°
	0° Blank (End Mill)					5° Blank				
6	...	72° 13'	50° 55'	...	...	80° 4'	62° 34'	41° 41'	...	...
8	...	79 51	68 39	54° 44'	32° 57'	82 57	72 52	61 47	48° 0'	25° 40'
10	...	82 38	74 40	65 12	52 26	83 50	76 31	68 35	59 11	46 4
12	...	84 9	77 52	70 32	61 2	84 14	78 25	72 10	64 52	55 5
14	...	85 8	79 54	73 51	66 10	84 27	79 36	74 24	68 23	60 28
16	...	85 49	81 20	76 10	69 40	84 35	80 25	75 57	70 49	64 7
18	...	86 19	82 23	77 52	72 13	84 41	81 1	77 6	72 36	66 47
20	...	86 43	83 13	79 11	74 11	84 45	81 29	77 59	73 59	68 50
22	...	87 2	83 52	80 14	75 44	84 47	81 50	78 40	75 4	70 26
24	...	87 18	84 24	81 6	77 0	84 49	82 7	79 15	75 57	71 44
	10° Blank					15° Blank				
6	70° 34'	53° 50'	34° 3'	...	...	61° 49'	46° 12'	28° 4'	...	...
8	76 0	66 9	55 19	41° 56'	20° 39'	69 15	59 46	49 21	36° 34'	17° 34'
10	77 42	70 31	62 44	53 30	40 42	71 40	64 41	57 8	48 12	36 18
12	78 30	72 46	66 37	59 26	49 50	72 48	67 13	61 13	54 14	45 13
14	78 56	74 9	69 2	63 6	55 19	73 26	68 46	63 46	57 59	50 38
16	79 12	75 5	70 41	65 37	59 1	73 50	69 49	65 30	60 33	54 20
18	79 22	75 45	71 53	67 27	61 43	74 5	70 33	66 46	62 26	57 0
20	79 30	76 16	72 44	68 52	63 47	74 16	71 6	67 44	63 52	59 3
22	79 35	76 40	73 33	69 59	65 25	74 24	71 32	68 29	65 0	60 40
24	79 39	76 59	74 9	70 54	66 44	74 30	71 53	69 6	65 56	61 59
	20° Blank					25° Blank				
6	53° 57'	39° 36'	23° 18'	...	...	47° 0'	34° 6'	19° 33'	...	...
8	62 46	53 45	43 53	31° 53'	14° 31'	56 36	48 8	38 55	27° 47'	11° 33'
10	65 47	59 4	51 50	43 18	32 1	60 2	53 40	46 47	38 43	27 47
12	67 12	61 49	56 2	49 18	40 40	61 42	56 33	51 2	44 38	36 10
14	68 0	63 29	58 39	53 4	46 0	62 38	58 19	53 41	48 20	41 22
16	68 30	64 36	60 26	55 39	49 38	63 13	59 29	55 29	50 53	44 57
18	68 50	65 24	61 44	57 32	52 17	63 37	60 19	56 48	52 46	47 34
20	69 3	65 59	62 43	58 58	54 18	63 53	60 56	57 47	54 11	49 33
22	69 14	66 28	63 30	60 7	55 55	64 5	61 25	58 34	55 19	51 9
24	69 21	66 49	64 7	61 2	57 12	64 14	61 47	59 12	56 13	52 26
	30° Blank					35° Blank				
6	40° 54'	29° 22'	16° 32'	...	...	35° 32'	25° 19'	14° 3'	...	...
8	50 46	42 55	34 24	24° 12'	10° 14'	45 17	38 5	30 18	21° 4'	8° 41'
10	54 29	48 30	42 3	34 31	24 44	49 7	43 33	37 35	30 38	21 40
12	56 18	51 26	46 14	40 12	32 32	51 3	46 30	41 39	36 2	28 55
14	57 21	53 15	48 52	43 49	37 27	52 9	48 19	44 12	39 28	33 33
16	58 0	54 27	50 39	46 19	40 52	52 50	49 20	45 56	41 51	36 45
18	58 26	55 18	51 57	48 7	43 20	53 18	50 21	47 12	43 36	39 8
20	58 44	55 55	52 56	49 30	45 15	53 38	50 59	48 10	44 57	40 57
22	58 57	56 24	53 42	50 36	46 46	53 53	51 29	48 56	46 1	42 24
24	59 8	56 48	54 20	51 30	48 0	54 4	51 53	49 32	46 52	43 35



Angles of Elevation for Milling Straight Teeth in 40-, 45-, 50-, 55-, 60-, 65-, 70-, and 75-degree Blanks Using Single-Angle Fluting Cutters

No. of Teeth	Angle of Fluting Cutter									
	40° Blank					45° Blank				
	90°	80°	70°	60°	50°	90°	80°	70°	60°	50°
6	30° 48'	21° 48'	11° 58'	...	...	26° 34'	18° 43'	10° 11'	...	...
8	40 7	33 36	26 33	18° 16'	7° 23'	35 16	29 25	23 8	15° 48'	5° 58'
10	43 57	38 51	33 32	27 3	18 55	38 58	34 21	29 24	23 40	16 10
12	45 54	41 43	37 14	32 3	25 33	40 54	37 5	33 0	28 18	22 13
14	47 3	43 29	39 41	35 19	29 51	42 1	38 46	35 17	31 18	26 9
16	47 45	44 39	41 21	37 33	32 50	42 44	39 54	36 52	33 24	28 57
18	48 14	45 29	42 34	39 13	35 5	43 13	40 42	38 1	34 56	30 1
20	48 35	46 7	43 30	40 70	36 47	43 34	41 18	38 53	36 8	32 37
22	48 50	46 36	44 13	41 30	38 8	43 49	41 46	39 34	37 5	34 53
24	49 1	46 58	44 48	42 19	39 15	44 0	42 7	40 7	37 50	35 55
	50° Blank					55° Blank				
6	22° 45'	15° 58'	8° 38'	...	...	19° 17'	13° 30'	7° 15'	...	...
8	30 41	25 31	19 59	13° 33'	5° 20'	26 21	21 52	17 3	11° 30'	4° 17'
10	34 10	30 2	25 39	20 32	14 9	29 32	25 55	22 3	17 36	11 52
12	36 0	32 34	28 53	24 42	19 27	31 14	28 12	24 59	21 17	16 32
14	37 5	34 9	31 1	27 26	22 58	32 15	29 39	26 53	23 43	19 40
16	37 47	35 13	32 29	29 22	25 30	32 54	30 38	28 12	25 26	21 54
18	38 15	35 58	33 33	30 46	27 21	33 21	31 20	29 10	26 43	23 35
20	38 35	36 32	34 21	31 52	28 47	33 40	31 51	29 54	27 42	24 53
22	38 50	36 58	34 59	32 44	29 57	33 54	32 15	30 29	28 28	25 55
24	39 1	37 19	35 30	33 25	30 52	34 5	32 34	30 57	29 7	26 46
	60° Blank					65° Blank				
6	16° 6'	11° 12'	6° 2'	...	...	13° 7'	9° 8'	4° 53'	...	...
8	22 13	18 24	14 19	9° 37'	3° 44'	18 15	15 6	11 42	7° 50'	3° 1'
10	25 2	21 56	18 37	14 49	10 5	20 40	18 4	15 19	12 9	8 15
12	26 34	23 57	21 10	17 59	14 13	21 59	19 48	17 28	14 49	11 32
14	27 29	25 14	22 51	20 6	16 44	22 48	20 55	18 54	16 37	13 48
16	28 5	26 7	24 1	21 37	18 40	23 18	21 39	19 53	17 53	15 34
18	28 29	26 44	24 52	22 44	20 6	23 40	22 11	20 37	18 50	16 37
20	28 46	27 11	25 30	23 35	21 14	23 55	22 35	21 10	19 33	17 34
22	29 0	27 34	26 2	24 17	22 8	24 6	22 53	21 36	20 8	18 20
24	29 9	27 50	26 26	24 50	22 52	24 15	23 8	21 57	20 36	18 57
	70° Blank					75° Blank				
6	10° 18'	7° 9'	3° 48'	...	...	7° 38'	5° 19'	2° 50'	...	...
8	14 26	11 55	9 14	6° 9'	2° 21'	10 44	8 51	6 51	4° 34'	1° 45'
10	16 25	14 21	12 8	9 37	6 30	12 14	10 40	9 1	7 8	4 49
12	17 30	15 45	13 53	11 45	9 8	13 4	11 45	10 21	8 45	6 47
14	18 9	16 38	15 1	13 11	10 55	13 34	12 26	11 13	9 50	8 7
16	18 35	17 15	15 50	14 13	12 13	13 54	12 54	11 50	10 37	9 7
18	18 53	17 42	16 26	14 59	13 13	14 8	13 14	12 17	11 12	9 51
20	19 6	18 1	16 53	15 35	13 59	14 18	13 29	12 38	11 39	10 27
22	19 15	18 16	17 15	16 3	14 35	14 25	13 41	12 53	12 0	10 54
24	19 22	18 29	17 33	16 25	15 5	14 31	13 50	13 7	12 18	11 18

Angles of Elevation for Milling Straight Teeth in 80- and 85-degree Blanks Using Single-Angle Fluting Cutters

No. of Teeth	Angle of Fluting Cutter									
	90°	80°	70°	60°	50°	90°	80°	70°	60°	50°
	80° Blank					85° Blank				
6	5° 2'	3° 30'	1° 52'	...	...	2° 30'	1° 44'	0° 55'	...	...
8	7 6	5 51	4 31	3° 2'	1° 8'	3 32	2 55	2 15	1° 29'	0° 34'
10	8 7	7 5	5 59	4 44	3 11	4 3	3 32	2 59	2 21	1 35
12	8 41	7 48	6 52	5 48	4 29	4 20	3 53	3 25	2 53	2 15
14	9 2	8 16	7 28	6 32	5 24	4 30	4 7	3 43	3 15	2 42
16	9 15	8 35	7 51	7 3	6 3	4 37	4 17	3 56	3 30	3 1
18	9 24	8 48	8 10	7 26	6 33	4 42	4 24	4 5	3 43	3 16
20	9 31	8 58	8 24	7 44	6 56	4 46	4 29	4 12	3 52	3 28
22	9 36	9 6	8 35	7 59	7 15	4 48	4 33	4 18	3 59	3 37
24	9 40	9 13	8 43	8 11	7 30	4 50	4 36	4 22	4 5	3 45

**Spline-Shaft Milling Cutter.**—The most efficient method of forming splines on shafts is by hobbing, but special milling cutters may also be used. Since the cutter forms the space between adjacent splines, it must be made to suit the number of splines and the root diameter of the shaft. The cutter angle *B* equals 360 degrees divided by the number of splines. The following formulas are for determining the chordal width *C* at the root of the splines or the chordal width across the concave edge of the cutter. In these formulas, *A* = angle between center line of spline and a radial line passing through the intersection of the root circle and one side of the spline; *W* = width of spline; *d* = root diameter of splined shaft; *C* = chordal width at root circle between adjacent splines; *N* = number of splines.

$$\sin A = \frac{W}{d} \quad C = d \times \sin\left(\frac{180}{N} - A\right)$$

Splines of involute form are often used in preference to the straight-sided type. Dimensions of the American Standard involute splines and hobs are given in the section on splines.

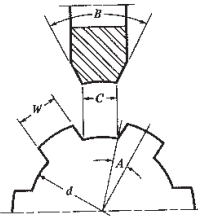

Cutter Grinding

**Wheels for Sharpening Milling Cutters.**—Milling cutters may be sharpened either by using the periphery of a disk wheel or the face of a cup wheel. The latter grinds the lands of the teeth flat, whereas the periphery of a disk wheel leaves the teeth slightly concave back of the cutting edges. The concavity produced by disk wheels reduces the effective clearance angle on the teeth, the effect being more pronounced for wheels of small diameter than for wheels of large diameter. For this reason, large diameter wheels are preferred

when sharpening milling cutters with disk type wheels. Irrespective of what type of wheel is used to sharpen a milling cutter, any burrs resulting from grinding should be carefully removed by a hand stoning operation. Stoning also helps to reduce the roughness of grinding marks and improves the quality of the finish produced on the surface being machined. Unless done very carefully, hand stoning may dull the cutting edge. Stoning may be avoided and a sharper cutting edge produced if the wheel rotates toward the cutting edge, which requires that the operator maintain contact between the tool and the rest while the wheel rotation is trying to move the tool away from the rest. Though slightly more difficult, this method will eliminate the burr.

Specifications of Grinding Wheels for Sharpening Milling Cutters

Cutter Material	Operation	Grinding Wheel			
		Abrasive Material	Grain Size	Grade	Bond
Carbon Tool Steel	Roughing Finishing	Aluminum Oxide	46-60	K	Vitrified
		Aluminum Oxide	100	H	Vitrified
High-speed Steel:	Roughing	Aluminum Oxide	60	K,H	Vitrified
		Aluminum Oxide	100	H	Vitrified
18-4-1 {	Finishing	Aluminum Oxide	80	F,G,H	Vitrified
		Aluminum Oxide	100	H	Vitrified
18-4-2 †	Roughing Finishing	Aluminum Oxide	46	H,K,L,N	Vitrified
		Aluminum Oxide	100-120	H	Vitrified
Cast Non-Ferrous Tool Material	Roughing Finishing	Aluminum Oxide	46	H,K,L,N	Vitrified
		Aluminum Oxide	100-120	H	Vitrified
Sintered Carbide	Roughing after Brazing	Silicon Carbide	60	G	Vitrified
		Diamond	100	a	Resinoid
			Up to 500	a	Resinoid
Carbon Tool Steel and High-Speed Steel <sup>b</sup>	Roughing Finishing	Cubic Boron Nitride	80-100	R,P	Resinoid
		Cubic Boron Nitride	100-120	S,T	Resinoid

<sup>a</sup>Not indicated in diamond wheel markings.

<sup>b</sup>For hardnesses above Rockwell C 56.

**Wheel Speeds and Feeds for Sharpening Milling Cutters.**—Relatively low cutting speeds should be used when sharpening milling cutters to avoid tempering and heat checking. Dry grinding is recommended in all cases except when diamond wheels are employed. The surface speed of grinding wheels should be in the range of 4500 to 6500 feet per minute for grinding milling cutters of high-speed steel or cast non-ferrous tool material. For sintered carbide cutters, 5000 to 5500 feet per minute should be used.

The maximum stock removed per pass of the grinding wheel should not exceed about 0.0004 inch for sintered carbide cutters; 0.003 inch for large high-speed steel and cast non-ferrous tool material cutters; and 0.0015 inch for narrow saws and slotting cutters of high-speed steel or cast non-ferrous tool material. The stock removed per pass of the wheel may be increased for backing-off operations such as the grinding of secondary clearance behind the teeth since there is usually a sufficient body of metal to carry off the heat.

**Clearance Angles for Milling Cutter Teeth.**—The clearance angle provided on the cutting edges of milling cutters has an important bearing on cutter performance, cutting efficiency, and cutter life between sharpenings. It is desirable in all cases to use a clearance angle as small as possible so as to leave more metal back of the cutting edges for better heat dissipation and to provide maximum support. Excessive clearance angles not only weaken the cutting edges, but also increase the likelihood of "chatter" which will result in poor finish on the machined surface and reduce the life of the cutter. According to The Cincinnati Milling Machine Co., milling cutters used for general purpose work and having diameters

from  $\frac{1}{8}$  to 3 inches should have clearance angles from 13 to 5 degrees, respectively, decreasing proportionately as the diameter increases. General purpose cutters over 3 inches in diameter should be provided with a clearance angle of 4 to 5 degrees. The land width is usually  $\frac{1}{64}$ ,  $\frac{1}{32}$ , and  $\frac{1}{16}$  inch, respectively, for small, medium, and large cutters.

The primary clearance or relief angle for best results varies according to the material being milled about as follows: low carbon, high carbon, and alloy steels, 3 to 5 degrees; cast iron and medium and hard bronze, 4 to 7 degrees; brass, soft bronze, aluminum, magnesium, plastics, etc., 10 to 12 degrees. When milling cutters are resharpened, it is customary to grind a secondary clearance angle of 3 to 5 degrees behind the primary clearance angle to reduce the land width to its original value and thus avoid interference with the surface to be milled. A general formula for plain milling cutters, face mills, and form relieved cutters which gives the clearance angle  $C$ , in degrees, necessitated by the feed per revolution  $F$ , in inches, the width of land  $L$ , in inches, the depth of cut  $d$ , in inches, the cutter diameter  $D$ , in inches, and the Brinell hardness number  $B$  of the work being cut is:

$$C = \frac{45860}{DB} \left( 1.5L + \frac{F}{\pi D} \sqrt{d(D-d)} \right)$$

**Rake Angles for Milling Cutters.**—In peripheral milling cutters, the rake angle is generally defined as the angle in degrees that the tooth face deviates from a radial line to the cutting edge. In face milling cutters, the teeth are inclined with respect to both the radial and axial lines. These angles are called *radial* and *axial* rake, respectively. The radial and axial rake angles may be positive, zero, or negative.

Positive rake angles should be used whenever possible for all types of high-speed steel milling cutters. For sintered carbide tipped cutters, zero and negative rake angles are frequently employed to provide more material back of the cutting edge to resist shock loads.

**Rake Angles for High-speed Steel Cutters:** Positive rake angles of 10 to 15 degrees are satisfactory for milling steels of various compositions with plain milling cutters. For softer materials such as magnesium and aluminum alloys, the rake angle may be 25 degrees or more. Metal slitting saws for cutting alloy steel usually have rake angles from 5 to 10 degrees, whereas zero and sometimes negative rake angles are used for saws to cut copper and other soft non-ferrous metals to reduce the tendency to "hog in." Form relieved cutters usually have rake angles of 0, 5, or 10 degrees. Commercial face milling cutters usually have 10 degrees positive radial and axial rake angles for general use in milling cast iron, forged and alloy steel, brass, and bronze; for milling castings and forgings of magnesium and free-cutting aluminum and their alloys, the rake angles may be increased to 25 degrees positive or more, depending on the operating conditions; a smaller rake angle is used for abrasive or difficult to machine aluminum alloys.

**Cast Non-ferrous Tool Material Milling Cutters:** Positive rake angles are generally provided on milling cutters using cast non-ferrous tool materials although negative rake angles may be used advantageously for some operations such as those where shock loads are encountered or where it is necessary to eliminate vibration when milling thin sections.

**Sintered Carbide Milling Cutters:** Peripheral milling cutters such as slab mills, slotting cutters, saws, etc., tipped with sintered carbide, generally have negative radial rake angles of 5 degrees for soft low carbon steel and 10 degrees or more for alloy steels. Positive axial rake angles of 5 and 10 degrees, respectively, may be provided, and for slotting saws and cutters, 0 degree axial rake may be used. On soft materials such as free-cutting aluminum alloys, positive rake angles of 10 to 20 degrees are used. For milling abrasive or difficult to machine aluminum alloys, small positive or even negative rake angles are used.

**Eccentric Type Radial Relief.**—When the radial relief angles on peripheral teeth of milling cutters are ground with a disc type grinding wheel in the conventional manner the ground surfaces on the lands are slightly concave, conforming approximately to the radius of the wheel. A flat land is produced when the radial relief angle is ground with a cup

wheel. Another entirely different method of grinding the radial angle is by the eccentric method, which produces a slightly convex surface on the land. If the radial relief angle at the cutting edge is equal for all of the three types of land mentioned, it will be found that the land with the eccentric relief will drop away from the cutting edge a somewhat greater distance for a given distance around the land than will the others. This is evident from a study of Table entitled, "Indicator Drops for Checking Radial Relief Angles on Peripheral Teeth." This feature is an advantage of the eccentric type relief which also produces an excellent finish.

Indicator Drops for Checking the Radial Relief Angle on Peripheral Teeth

Cutter Diameter, Inch	Recom. Range of Radial Relief Angles, Degrees	Checking Distance, Inch	Indicator Drops, Inches				Recom. Max. Primary Lead Width, Inch
			For Flat and Concave Relief		For Eccentric Relief		
			Min.	Max.	Min.	Max.	
1/16	20-25	.005	.0014	.0019	.0020	.0026	.007
1/8	16-20	.005	.0012	.0015	.0015	.0019	.007
3/16	15-19	.010	.0018	.0026	.0028	.0037	.015
1/4	13-17	.010	.0017	.0024	.0024	.0032	.015
5/16	12-16	.010	.0016	.0023	.0022	.0030	.015
3/8	11-15	.010	.0015	.0022	.0020	.0028	.015
1/2	10-14	.015	.0017	.0028	.0027	.0039	.020
5/8	10-14	.015	.0018	.0029	.0027	.0039	.020
3/4	10-13	.015	.0019	.0027	.0027	.0035	.020
7/8	10-13	.015	.0020	.0028	.0027	.0035	.020
1	10-13	.015	.0020	.0029	.0027	.0035	.020
1 1/16	9-12	.020	.0022	.0032	.0032	.0044	.025
1 1/8	9-12	.020	.0022	.0033	.0032	.0043	.025
1 1/4	9-12	.020	.0023	.0034	.0032	.0043	.025
1 1/2	9-12	.020	.0024	.0034	.0032	.0043	.025
1 3/8	9-12	.020	.0024	.0035	.0032	.0043	.025
1 1/2	8-11	.020	.0022	.0032	.0028	.0039	.025
1 5/8	8-11	.030	.0029	.0045	.0043	.0059	.035
1 3/4	8-11	.030	.0030	.0046	.0043	.0059	.035
1 7/8	8-11	.030	.0031	.0047	.0043	.0059	.035
2	8-11	.030	.0032	.0048	.0043	.0059	.035
2 1/16	7-10	.030	.0027	.0043	.0037	.0054	.035
2 1/8	7-10	.030	.0028	.0044	.0037	.0054	.035
2 1/4	7-10	.030	.0029	.0045	.0037	.0053	.035
2 3/8	6-9	.030	.0024	.0040	.0032	.0048	.035
2 1/2	6-9	.030	.0025	.0041	.0032	.0048	.035
2 5/8	6-9	.030	.0026	.0041	.0032	.0048	.035
2 3/4	6-9	.030	.0026	.0042	.0032	.0048	.035
2 7/8	6-9	.030	.0026	.0042	.0032	.0048	.035
3	6-9	.030	.0027	.0043	.0032	.0048	.035
3 1/8	6-9	.030	.0027	.0043	.0032	.0048	.035
3 1/4	5-8	.030	.0022	.0038	.0026	.0042	.040
3 3/8	5-8	.030	.0023	.0039	.0026	.0042	.040
3 1/2	5-8	.030	.0023	.0039	.0026	.0042	.040
3 5/8	5-8	.030	.0024	.0040	.0026	.0042	.040
4	5-8	.030	.0024	.0040	.0026	.0042	.040
4 1/8	4-7	.030	.0019	.0035	.0021	.0037	.047
4 1/4	4-7	.030	.0019	.0035	.0021	.0037	.047
4 3/8	4-7	.030	.0019	.0035	.0021	.0037	.047
4 1/2	4-7	.030	.0020	.0036	.0021	.0037	.060
4 5/8	4-7	.030	.0020	.0036	.0021	.0037	.060
5	4-7	.030	.0020	.0036	.0021	.0037	.060
5 1/8	4-7	.030	.0020	.0036	.0021	.0037	.060
5 1/4	4-7	.030	.0020	.0036	.0021	.0037	.060
5 3/8	4-7	.030	.0020	.0036	.0021	.0037	.060
5 1/2	4-7	.030	.0020	.0036	.0021	.0037	.060
5 5/8	4-7	.030	.0020	.0036	.0021	.0037	.060
6	4-7	.030	.0020	.0036	.0021	.0037	.060
6 1/8	4-7	.030	.0020	.0036	.0021	.0037	.060
6 1/4	4-7	.030	.0020	.0036	.0021	.0037	.060
6 3/8	4-7	.030	.0020	.0036	.0021	.0037	.060
6 1/2	4-7	.030	.0020	.0036	.0021	.0037	.060
6 5/8	4-7	.030	.0020	.0036	.0021	.0037	.060
7	4-7	.030	.0020	.0036	.0021	.0037	.060
7 1/8	4-7	.030	.0020	.0036	.0021	.0037	.060
7 1/4	4-7	.030	.0020	.0036	.0021	.0037	.060
7 3/8	4-7	.030	.0020	.0036	.0021	.0037	.060
7 1/2	4-7	.030	.0020	.0036	.0021	.0037	.060
7 5/8	4-7	.030	.0020	.0036	.0021	.0037	.060
8	4-7	.030	.0020	.0036	.0021	.0037	.060
8 1/8	4-7	.030	.0020	.0036	.0021	.0037	.060
8 1/4	4-7	.030	.0020	.0036	.0021	.0037	.060
8 3/8	4-7	.030	.0020	.0036	.0021	.0037	.060
8 1/2	4-7	.030	.0020	.0036	.0021	.0037	.060
8 5/8	4-7	.030	.0020	.0036	.0021	.0037	.060
9	4-7	.030	.0020	.0036	.0021	.0037	.060
9 1/8	4-7	.030	.0020	.0036	.0021	.0037	.060
9 1/4	4-7	.030	.0020	.0036	.0021	.0037	.060
9 3/8	4-7	.030	.0020	.0036	.0021	.0037	.060
9 1/2	4-7	.030	.0020	.0036	.0021	.0037	.060
9 5/8	4-7	.030	.0020	.0036	.0021	.0037	.060
10	4-7	.030	.0020	.0036	.0021	.0037	.060
10 1/8	4-7	.030	.0020	.0036	.0021	.0037	.060
10 1/4	4-7	.030	.0020	.0036	.0021	.0037	.060
10 3/8	4-7	.030	.0020	.0036	.0021	.0037	.060
10 1/2	4-7	.030	.0020	.0036	.0021	.0037	.060
10 5/8	4-7	.030	.0020	.0036	.0021	.0037	.060
11	4-7	.030	.0020	.0036	.0021	.0037	.060
11 1/8	4-7	.030	.0020	.0036	.0021	.0037	.060
11 1/4	4-7	.030	.0020	.0036	.0021	.0037	.060
11 3/8	4-7	.030	.0020	.0036	.0021	.0037	.060
11 1/2	4-7	.030	.0020	.0036	.0021	.0037	.060
11 5/8	4-7	.030	.0020	.0036	.0021	.0037	.060
12	4-7	.030	.0020	.0036	.0021	.0037	.060

The setup for grinding an eccentric relief is shown in Fig. 2. In this setup the point of contact between the cutter and the tooth rest must be in the same plane as the centers, or axes, of the grinding wheel and the cutter. A wide face is used on the grinding wheel, which is trued and dressed at an angle with respect to the axis of the cutter. An alternate method is to tilt the wheel at this angle. Then as the cutter is traversed and rotated past the grinding wheel while in contact with the tooth rest, an eccentric relief will be generated by the angular face of the wheel. This type of relief can only be ground on the peripheral teeth on milling cutters having helical flutes because the combination of the angular wheel face and the twisting motion of the cutter is required to generate the eccentric relief. Therefore, an eccentric relief cannot be ground on the peripheral teeth of straight fluted cutters.

Table 4 is a table of wheel angles for grinding an eccentric relief for different combinations of relief angles and helix angles. When angles are required that cannot be found in this table, the wheel angle, *W*, can be calculated by using the following formula, in which *R* is the radial relief angle and *H* is the helix angle of the flutes on the cutter.

$$\tan W = \tan R \times \tan H$$

**Table 4. Grinding Wheel Angles for Grinding Eccentric Type Radial Relief Angle**

Radial Relief Angle, <i>R</i> , Degrees	Helix Angle of Cutter Flutes, <i>H</i> , Degrees							
	12	18	20	30	40	45	50	52
	Wheel Angle, <i>W</i> , Degrees							
1	0°13'	0°19'	0°22'	0°35'	0°50'	1°00'	1°12'	1°17'
2	0°26'	0°39'	0°44'	1°09'	1°41'	2°00'	2°23'	2°34'
3	0°38'	0°59'	1°06'	1°44'	2°31'	3°00'	3°34'	3°50'
4	0°51'	1°18'	1°27'	2°19'	3°21'	4°00'	4°46'	5°07'
5	1°04'	1°38'	1°49'	2°53'	4°12'	5°00'	5°57'	6°23'
6	1°17'	1°57'	2°11'	3°28'	5°02'	6°00'	7°08'	7°40'
7	1°30'	2°17'	2°34'	4°03'	5°53'	7°00'	8°19'	8°56'
8	1°43'	2°37'	2°56'	4°38'	6°44'	8°00'	9°30'	10°12'
9	1°56'	2°57'	3°18'	5°13'	7°34'	9°00'	10°41'	11°28'
10	2°09'	3°17'	3°40'	5°49'	8°25'	10°00'	11°52'	12°43'
11	2°22'	3°37'	4°03'	6°24'	9°16'	11°00'	13°03'	13°58'
12	2°35'	3°57'	4°25'	7°00'	10°07'	12°00'	14°13'	15°13'
13	2°49'	4°17'	4°48'	7°36'	10°58'	13°00'	15°23'	16°28'
14	3°02'	4°38'	5°11'	8°11'	11°49'	14°00'	16°33'	17°42'
15	3°16'	4°59'	5°34'	8°48'	12°40'	15°00'	17°43'	18°56'
16	3°29'	5°19'	5°57'	9°24'	13°32'	16°00'	18°52'	20°09'
17	3°43'	5°40'	6°21'	10°01'	14°23'	17°00'	20°01'	21°22'
18	3°57'	6°02'	6°45'	10°37'	15°15'	18°00'	21°10'	22°35'
19	4°11'	6°23'	7°09'	11°15'	16°07'	19°00'	22°19'	23°47'
20	4°25'	6°45'	7°33'	11°52'	16°59'	20°00'	23°27'	24°59'
21	4°40'	7°07'	7°57'	12°30'	17°51'	21°00'	24°35'	26°10'
22	4°55'	7°29'	8°22'	13°08'	18°44'	22°00'	25°43'	27°21'
23	5°09'	7°51'	8°47'	13°46'	19°36'	23°00'	26°50'	28°31'
24	5°24'	8°14'	9°12'	14°25'	20°29'	24°00'	27°57'	29°41'
25	5°40'	8°37'	9°38'	15°04'	21°22'	25°00'	29°04'	30°50'

**Indicator Drop Method of Checking Relief and Rake Angles.**—The most convenient and inexpensive method of checking the relief and rake angles on milling cutters is by the indicator drop method. Three tables, Tables 5, 6, and 7, of indicator drops are provided in this section, for checking radial relief angles on the peripheral teeth, relief angles on side and end teeth, and rake angles on the tooth faces.

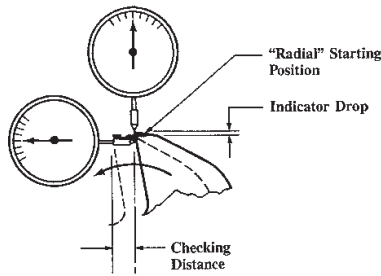

Fig. 1. Setup for Checking the Radial Relief Angle by Indicator Drop Method

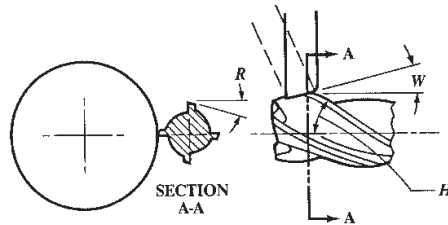

Fig. 2. Setup for Grinding Eccentric Type Radial Relief Angle

**Table 5. Indicator Drops for Checking Relief Angles on Side Teeth and End Teeth**

Checking Distance, inch	Given Relief Angle								
	1°	2°	3°	4°	5°	6°	7°	8°	9°
	Indicator Drop, inch								
.005	.00009	.00017	.00026	.00035	.0004	.0005	.0006	.0007	.0008
.010	.00017	.00035	.00052	.0007	.0009	.0011	.0012	.0014	.0016
.015	.00026	.0005	.00079	.0010	.0013	.0016	.0018	.0021	.0024
.031	.00054	.0011	.0016	.0022	.0027	.0033	.0038	.0044	.0049
.047	.00082	.0016	.0025	.0033	.0041	.0049	.0058	.0066	.0074
.062	.00108	.0022	.0032	.0043	.0054	.0065	.0076	.0087	.0098

Table 6. Indicator Drops for Checking Rake Angles on Milling Cutter Face

Set indicator to read zero on horizontal plane passing through cutter axis. Zero cutting edge against indicator.

Move cutter or indicator measuring distance.

Rate Angle, Deg.	Measuring Distance, inch				Rate Angle, Deg.	Measuring Distance, inch			
	.031	.062	.094	.125		.031	.062	.094	.125
	Indicator Drop, inch					Indicator Drop, inch			
1	.0005	.0011	.0016	.0022	11	.0060	.0121	.0183	.0243
2	.0011	.0022	.0033	.0044	12	.0066	.0132	.0200	.0266
3	.0016	.0032	.0049	.0066	13	.0072	.0143	.0217	.0289
4	.0022	.0043	.0066	.0087	14	.0077	.0155	.0234	.0312
5	.0027	.0054	.0082	.0109	15	.0083	.0166	.0252	.0335
6	.0033	.0065	.0099	.0131	16	.0089	.0178	.0270	.0358
7	.0038	.0076	.0115	.0153	17	.0095	.0190	.0287	.0382
8	.0044	.0087	.0132	.0176	18	.0101	.0201	.0305	.0406
9	.0049	.0098	.0149	.0198	19	.0107	.0213	.0324	.0430
10	.0055	.0109	.0166	.0220	20	.0113	.0226	.0342	.0455

The setup for checking the radial relief angle is illustrated in Fig. 1. Two dial test indicators are required, one of which should have a sharp pointed contact point. This indicator is positioned so that the axis of its spindle is vertical, passing through the axis of the cutter. The cutter may be held by its shank in the spindle of a tool and cutter grinder workhead, or between centers while mounted on a mandrel. The cutter is rotated to the position where the vertical indicator contacts a cutting edge. The second indicator is positioned with its spindle axis horizontal and with the contact point touching the tool face just below the cutting edge. With both indicators adjusted to read zero, the cutter is rotated a distance equal to the checking distance, as determined by the reading on the second indicator. Then the indicator drop is read on the vertical indicator and checked against the values in the tables. The indicator drops for radial relief angles ground by a disc type grinding wheel and those ground with a cup wheel are so nearly equal that the values are listed together; values for the eccentric type relief are listed separately, since they are larger. A similar procedure is used to check the relief angles on the side and end teeth of milling cutters; however, only one indicator is used. Also, instead of rotating the cutter, the indicator or the cutter must be moved a distance equal to the checking distance in a straight line.



Various Set-ups Used in Grinding the Clearance Angle on Milling Cutter Teeth

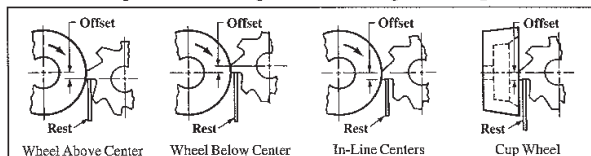

Distance to Set Center of Wheel Above the Cutter Center (Disk Wheel)

Dia. of Wheel, Inches	Desired Clearance Angle, Degrees											
	1	2	3	4	5	6	7	8	9	10	11	12
	*Distance to Offset Wheel Center Above Cutter Center, Inches											
3	.026	.052	.079	.105	.131	.157	.183	.209	.235	.260	.286	.312
4	.035	.070	.105	.140	.174	.209	.244	.278	.313	.347	.382	.416
5	.044	.087	.131	.174	.218	.261	.305	.348	.391	.434	.477	.520
6	.052	.105	.157	.209	.261	.314	.366	.417	.469	.521	.572	.624
7	.061	.122	.183	.244	.305	.366	.427	.487	.547	.608	.668	.728
8	.070	.140	.209	.279	.349	.418	.488	.557	.626	.695	.763	.832
9	.079	.157	.236	.314	.392	.470	.548	.626	.704	.781	.859	.936
10	.087	.175	.262	.349	.436	.523	.609	.696	.782	.868	.954	1.040

\*Calculated from the formula: Offset = Cutter Diameter × 1/2 × Sine of Clearance Angle.

Distance to Set Center of Wheel Below the Cutter Center (Disk Wheel)

Dia. of Cutter, Inches	Desired Clearance Angle, Degrees											
	1	2	3	4	5	6	7	8	9	10	11	12
	*Distance to Offset Wheel Center Below Cutter Center, Inches											
2	.017	.035	.052	.070	.087	.105	.122	.139	.156	.174	.191	.208
3	.026	.052	.079	.105	.131	.157	.183	.209	.235	.260	.286	.312
4	.035	.070	.105	.140	.174	.209	.244	.278	.313	.347	.382	.416
5	.044	.087	.131	.174	.218	.261	.305	.348	.391	.434	.477	.520
6	.052	.105	.157	.209	.261	.314	.366	.417	.469	.521	.572	.624
7	.061	.122	.183	.244	.305	.366	.427	.487	.547	.608	.668	.728
8	.070	.140	.209	.279	.349	.418	.488	.557	.626	.695	.763	.832
9	.079	.157	.236	.314	.392	.470	.548	.626	.704	.781	.859	.936
10	.087	.175	.262	.349	.436	.523	.609	.696	.782	.868	.954	1.040

Distance to Set Tooth Rest Below Center Line of Wheel and Cutter.—When the clearance angle is ground with a disk type wheel by keeping the center line of the wheel in line with the center line of the cutter, the tooth rest should be lowered by an amount given by the following formula:

$$\text{Offset} = \frac{\text{Wheel Diam.} \times \text{Cutter Dia.} \times \text{Sine of One-half the Clearance Angle}}{\text{Wheel Dia.} + \text{Cutter Dia.}}$$

Distance to Set Tooth Rest Below Cutter Center When Cup Wheel is Used.—When the clearance is ground with a cup wheel, the tooth rest is set below the center of the cutter the same amount as given in the table for "Distance to Set Center of Wheel Below the Cutter Center (Disk Wheel)."

## REAMERS

**Hand Reamers.**—Hand reamers are made with both straight and helical flutes. Helical flutes provide a shearing cut and are especially useful in reaming holes having keyways or grooves, as these are bridged over by the helical flutes, thus preventing binding or chattering. Hand reamers are made in both solid and expansion forms. The American standard dimensions for solid forms are given in the accompanying table. The expansion type is useful whenever, in connection with repair or other work, it is necessary to enlarge a reamed hole by a few thousandths of an inch. The expansion form is split through the fluted section and a slight amount of expansion is obtained by screwing in a tapering plug. The diameter increase may vary from 0.005 to 0.008 inch for reamers up to about 1 inch diameter and from 0.010 to 0.012 inch for diameters between 1 and 2 inches. Hand reamers are tapered slightly on the end to facilitate starting them properly. The actual diameter of the shanks of commercial reamers may be from 0.002 to 0.005 inch under the reamer size. That part of the shank that is squared should be turned smaller in diameter than the shank itself, so that, when applying a wrench, no burr may be raised that may mar the reamed hole if the reamer is passed clear through it.

When fluting reamers, the cutter is so set with relation to the center of the reamer blank that the tooth gets a slight negative rake; that is, the cutter should be set *ahead* of the center, as shown in the illustration accompanying the table giving the amount to set the cutter ahead of the radial line. The amount is so selected that a tangent to the circumference of the reamer at the cutting point makes an angle of approximately 95 degrees with the front face of the cutting edge.

Amount to Set Cutter Ahead of Radial Line to Obtain Negative Front Rake

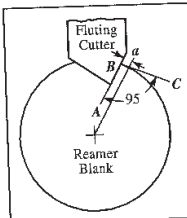

Size of Reamer	Dimension $a$ , Inches	Size of Reamer	Dimension $a$ , Inches	Size of Reamer	Dimension $a$ , Inches
$\frac{1}{4}$	0.011	$\frac{7}{8}$	0.038	2	0.087
$\frac{3}{8}$	0.016	1	0.044	$2\frac{1}{4}$	0.098
$\frac{1}{2}$	0.022	$1\frac{1}{4}$	0.055	$2\frac{1}{2}$	0.109
$\frac{5}{8}$	0.027	$1\frac{1}{2}$	0.066	$2\frac{3}{4}$	0.120
$\frac{3}{4}$	0.033	$1\frac{3}{4}$	0.076	3	0.131

When fluting reamers, it is necessary to "break up the flutes"; that is, to space the cutting edges unevenly around the reamer. The difference in spacing should be very slight and need not exceed two degrees one way or the other. The manner in which the breaking up of the flutes is usually done is to move the index head to which the reamer is fixed a certain amount more or less than it would be moved if the spacing were regular. A table is given showing the amount of this additional movement of the index crank for reamers with different numbers of flutes. When a reamer is provided with helical flutes, the angle of spiral should be such that the cutting edges make an angle of about 10 or at most 15 degrees with the axis of the reamer.

The relief of the cutting edges should be comparatively slight. An eccentric relief, that is, one where the land back of the cutting edge is convex, rather than flat, is used by one or two manufacturers, and is preferable for finishing reamers, as the reamer will hold its size longer. When hand reamers are used merely for removing stock, or simply for enlarging the holes, the flat relief is better, because the reamer has a keener cutting edge. The width of the land of the cutting edges should be about  $\frac{1}{32}$  inch for a  $\frac{1}{4}$ -inch,  $\frac{1}{16}$  inch for a 1-inch, and  $\frac{3}{32}$  inch for a 3-inch reamer.

Irregular Spacing of Teeth in Reamers

Number of flutes in reamer	4	6	8	10	12	14	16
Index circle to use	39	39	39	39	39	49	20
Before cutting	Move Spindle the Number of Holes below More or Less than for Regular Spacing						
2d flute	8 less	4 less	3 less	2 less	4 less	3 less	2 less
3d flute	4 more	5 more	5 more	3 more	4 more	2 more	2 more
4th flute	6 less	7 less	2 less	5 less	1 less	2 less	1 less
5th flute	...	6 more	4 more	2 more	3 more	4 more	2 more
6th flute	...	5 less	6 less	2 less	4 less	1 less	2 less
7th flute	...	...	2 more	3 more	4 more	3 more	1 more
8th flute	...	...	3 less	2 less	3 less	2 less	2 less
9th flute	...	...	...	5 more	2 more	1 more	2 more
10th flute	...	...	...	1 less	2 less	3 less	2 less
11th flute	...	...	...	...	3 more	3 more	1 more
12th flute	...	...	...	...	4 less	2 less	2 less
13th flute	...	...	...	...	...	2 more	2 more
14th flute	...	...	...	...	...	3 less	1 less
15th flute	...	...	...	...	...	...	2 more
16th flute	...	...	...	...	...	...	2 less

**Threaded-end Hand Reamers.**—Hand reamers are sometimes provided with a thread at the extreme point in order to give them a uniform feed when reaming. The diameter on the top of this thread at the point of the reamer is slightly smaller than the reamer itself, and the thread tapers upward until it reaches a dimension of from 0.003 to 0.008 inch, according to size, below the size of the reamer; at this point, the thread stops and a short neck about  $\frac{1}{16}$  inch wide separates the threaded portion from the actual reamer, which is provided with a short taper from  $\frac{3}{16}$  to  $\frac{7}{16}$  inch long up to where the standard diameter is reached. The length of the threaded portion and the number of threads per inch for reamers of this kind are given in the accompanying table. The thread employed is a sharp V-thread.

Dimensions for Threaded-End Hand Reamers

Sizes of Reamers	Length of Threaded Part	No. of Threads per Inch	Dia. of Thread at Point of Reamer	Sizes of Reamers	Length of Threaded Part	No. of Threads per Inch	Dia. of Thread at Point of Reamer
$\frac{1}{8}$ – $\frac{5}{16}$	$\frac{3}{8}$	32	Full diameter –0.006	$1\frac{1}{32}$ – $1\frac{1}{2}$	$\frac{5}{16}$	18	Full diameter –0.010
$\frac{11}{32}$ – $\frac{1}{2}$	$\frac{7}{16}$	28	–0.006	$1\frac{15}{32}$ –2	$\frac{3}{8}$	18	–0.012
$\frac{17}{32}$ – $\frac{3}{4}$	$\frac{1}{2}$	24	–0.008	$2\frac{1}{32}$ – $2\frac{1}{2}$	$\frac{7}{16}$	18	–0.015
$\frac{23}{32}$ –1	$\frac{5}{8}$	18	–0.008	$2\frac{17}{32}$ –3	$\frac{1}{2}$	18	–0.020

**Fluted Chucking Reamers.**—Reamers of this type are used in turret lathes, screw machines, etc., for enlarging holes and finishing them smooth and to the required size. The best results are obtained with a floating type of holder that permits a reamer to align itself with the hole being reamed. These reamers are intended for removing a small amount of metal, 0.005 to 0.010 inch being common allowances. Fluted chucking reamers are provided either with a straight shank or a standard taper shank. (See table for standard dimensions.)

**Rose Chucking Reamers.**—The rose type of reamer is used for enlarging cored or other holes. The cutting edges at the end are ground to a 45-degree bevel. This type of reamer will remove considerable metal in one cut. The cylindrical part of the reamer has no cutting

edges, but merely grooves cut for the full length of the reamer body, providing a way for the chips to escape and a channel for lubricant to reach the cutting edges. There is no relief on the cylindrical surface of the body part, but it is slightly back-tapered so that the diameter at the point with the beveled cutting edges is slightly larger than the diameter farther back. The back-taper should not exceed 0.001 inch per inch. This form of reamer usually produces holes slightly larger than its size and it is, therefore, always made from 0.005 to 0.010 inch smaller than its nominal size, so that it may be followed by a fluted reamer for finishing. The grooves on the cylindrical portion are cut by a convex cutter having a width equal to from one-fifth to one-fourth the diameter of the rose reamer itself. The depth of the groove should be from one-eighth to one-sixth the diameter of the reamer. The teeth at the end of the reamer are milled with a 75-degree angular cutter; the width of the land of the cutting edge should be about one-fifth the distance from tooth to tooth. If an angular cutter is preferred to a convex cutter for milling the grooves on the cylindrical portion, because of the higher cutting speed possible when milling, an 80-degree angular cutter slightly rounded at the point may be used.

Fluting Cutters for Reamers

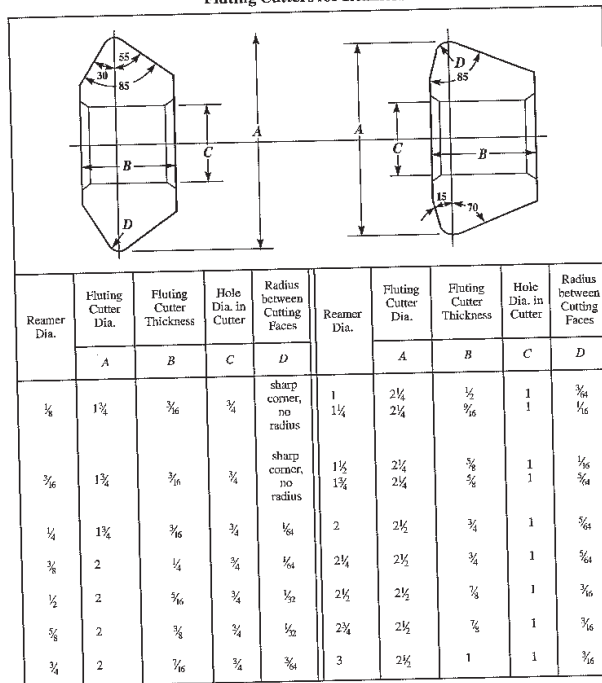

Dimensions of Formed Reamer Fluting Cutters

Reamer Size	No. of Teeth in Reamer	Cutter Dia. $D$	Cutter Width $A$	Hole Dia. $B$	Bearing Width $C$	Bevel Length $E$	Radius $F$	Radius $F$	Tooth Depth $H$	No. of Cutter Teeth
$\frac{1}{8}$ – $\frac{3}{16}$	6	$1\frac{1}{4}$	$\frac{3}{16}$	$\frac{1}{4}$	...	0.125	0.016	$\frac{1}{32}$	0.21	14
$\frac{1}{4}$ – $\frac{3}{8}$	6	$1\frac{1}{4}$	$\frac{1}{4}$	$\frac{1}{2}$	...	0.152	0.022	$\frac{1}{32}$	0.25	13
$\frac{3}{8}$ – $\frac{7}{16}$	6	$1\frac{1}{2}$	$\frac{3}{8}$	$\frac{3}{8}$	$\frac{1}{8}$	0.178	0.029	$\frac{1}{2}$	0.28	12
$\frac{1}{2}$ – $\frac{1}{2}$	6–8	2	$\frac{3}{16}$	$\frac{3}{8}$	$\frac{1}{8}$	0.205	0.036	$\frac{3}{16}$	0.30	12
$\frac{3}{4}$ –1	8	$2\frac{1}{2}$	$\frac{1}{2}$	$\frac{7}{8}$	$\frac{5}{16}$	0.232	0.042	$\frac{1}{16}$	0.32	12
$1\frac{1}{16}$ – $1\frac{1}{2}$	10	$2\frac{1}{4}$	$\frac{5}{16}$	$\frac{3}{4}$	$\frac{5}{16}$	0.258	0.049	$\frac{1}{4}$	0.38	11
$1\frac{1}{8}$ – $2\frac{1}{8}$	12	$2\frac{3}{8}$	$\frac{3}{8}$	$\frac{7}{8}$	$\frac{3}{16}$	0.285	0.056	$\frac{3}{16}$	0.40	11
$2\frac{1}{2}$ –3	14	$2\frac{3}{4}$	$\frac{11}{16}$	$\frac{7}{8}$	$\frac{3}{16}$	0.312	0.062	$\frac{1}{4}$	0.44	10

**Cutters for Fluting Rose Chucking Reamers.**—The cutters used for fluting rose chucking reamers on the end are 80-degree angular cutters for  $\frac{1}{4}$ - and  $\frac{3}{16}$ -inch diameter reamers; 75-degree angular cutters for  $\frac{3}{8}$ - and  $\frac{7}{16}$ -inch reamers; and 70-degree angular cutters for all larger sizes. The grooves on the cylindrical portion are milled with convex cutters of approximately the following sizes for given diameters of reamers:  $\frac{3}{32}$ -inch convex cutter for  $\frac{1}{2}$ -inch reamers;  $\frac{5}{16}$ -inch cutter for 1-inch reamers;  $\frac{3}{8}$ -inch cutter for  $1\frac{1}{2}$ -inch reamers;  $\frac{1}{2}$ -inch cutters for 2-inch reamers; and  $\frac{5}{16}$ -inch cutters for  $2\frac{1}{2}$ -inch reamers. The smaller sizes of reamers, from  $\frac{1}{4}$  to  $\frac{3}{8}$  inch in diameter, are often milled with regular double-angle reamer fluting cutters having a radius of  $\frac{1}{64}$  inch for  $\frac{1}{4}$ -inch reamer, and  $\frac{1}{32}$  inch for  $\frac{3}{16}$ - and  $\frac{3}{8}$ -inch sizes.

Vertical Adjustment of Tooth-rest for Grinding Clearance on Reamers

Size of Reamer	Hand Reamer for Steel. Cutting Clearance Land 0.006 inch Wide		Hand Reamer for Cast Iron and Bronze. Cutting Clearance Land 0.025 inch Wide		Chucking Reamer for Cast Iron and Bronze. Cutting Clearance Land 0.025 inch Wide		Rose Chucking Reamers for Steel
	For Cutting Clearance	For Second Clearance	For Cutting Clearance	For Second Clearance	For Cutting Clearance	For Second Clearance	
1/2	0.012	0.052	0.032	0.072	0.040	0.080	0.080
3/4	0.012	0.062	0.032	0.072	0.040	0.090	0.090
1	0.012	0.072	0.035	0.095	0.040	0.100	0.100
1 1/4	0.012	0.082	0.040	0.120	0.045	0.125	0.125
1 1/2	0.012	0.092	0.040	0.120	0.045	0.125	0.125
1 3/4	0.012	0.102	0.040	0.120	0.045	0.125	0.125
2	0.012	0.112	0.045	0.145	0.050	0.160	0.160
2 1/4	0.012	0.122	0.045	0.145	0.050	0.160	0.175
2 1/2	0.012	0.132	0.048	0.168	0.055	0.175	0.175
2 3/4	0.012	0.142	0.050	0.170	0.060	0.200	0.200
3	0.012	0.152	0.052	0.192	0.060	0.200	0.200
3 1/4	0.012	0.162	0.056	0.196	0.060	0.200	0.200
3 1/2	0.012	0.172	0.056	0.216	0.064	0.224	0.225
3 3/4	0.012	0.172	0.059	0.219	0.064	0.224	0.225
4	0.012	0.172	0.063	0.223	0.064	0.224	0.225
4 1/4	0.012	0.172	0.063	0.223	0.068	0.228	0.230
4 1/2	0.012	0.172	0.065	0.225	0.072	0.232	0.230
4 3/4	0.012	0.172	0.065	0.225	0.075	0.235	0.235
5	0.012	0.172	0.065	0.225	0.077	0.237	0.240
5 1/4	0.012	0.172	0.070	0.230	0.080	0.240	0.240
5 1/2	0.012	0.172	0.072	0.232	0.080	0.240	0.240
5 3/4	0.012	0.172	0.075	0.235	0.083	0.240	0.240
6	0.012	0.172	0.078	0.238	0.083	0.243	0.245
6 1/4	0.012	0.172	0.081	0.241	0.087	0.247	0.245
6 1/2	0.012	0.172	0.084	0.244	0.090	0.250	0.250
6 3/4	0.012	0.172	0.087	0.247	0.093	0.253	0.250
7	0.012	0.172	0.090	0.250	0.097	0.257	0.255
7 1/4	0.012	0.172	0.093	0.253	0.100	0.260	0.255
7 1/2	0.012	0.172	0.096	0.256	0.104	0.264	0.260
7 3/4	0.012	0.172	0.096	0.256	0.104	0.264	0.260
8	0.012	0.172	0.096	0.256	0.106	0.266	0.265
8 1/4	0.012	0.172	0.096	0.256	0.108	0.268	0.265
8 1/2	0.012	0.172	0.100	0.260	0.108	0.268	0.265
8 3/4	0.012	0.172	0.100	0.260	0.110	0.270	0.270
9	0.012	0.172	0.104	0.264	0.114	0.274	0.275
9 1/4	0.012	0.172	0.106	0.266	0.116	0.276	0.275
9 1/2	0.012	0.172	0.110	0.270	0.118	0.278	0.275

**Reamer Difficulties.**—Certain frequently occurring problems in reaming require remedial measures. These difficulties include the production of oversize holes, bellmouth holes, and holes with a poor finish. The following is taken from suggestions for correction of these difficulties by the National Twist Drill and Tool Co. and Winter Brothers Co.\*

**Oversize Holes:** The cutting of a hole oversize from the start of the reaming operations usually indicates a mechanical defect in the setup or reamer. Thus, the wrong reamer for the workpiece material may have been used or there may be inadequate workpiece support, inadequate or worn guide bushings, or misalignment of the spindles, bushings, or workpiece or runout of the spindle or reamer holder. The reamer itself may be defective due to chamfer runout or runout of the cutting end due to a bent or nonconcentric shank.

When reamers gradually start to cut oversize, it is due to pickup or galling, principally on the reamer margins. This condition is partly due to the workpiece material. Mild steels, certain cast irons, and some aluminum alloys are particularly troublesome in this respect.

Corrective measures include reducing the reamer margin widths to about 0.005 to 0.010 inch, use of hard case surface treatments on high-speed-steel reamers, either alone or in combination with black oxide treatments, and the use of a high-grade finish on the reamer faces, margins, and chamfer relief surfaces.

**Bellmouth Holes:** The cutting of a hole that becomes oversize at the entry end with the oversize decreasing gradually along its length always reflects misalignment of the cutting portion of the reamer with respect to the hole. The obvious solution is to provide improved guiding of the reamer by the use of accurate bushings and pilot surfaces. If this solution is not feasible, and the reamer is cutting in a vertical position, a flexible element may be employed to hold the reamer in such a way that it has both radial and axial float, with the hope that the reamer will follow the original hole and prevent the bellmouth condition.

In horizontal setups where the reamer is held fixed and the workpiece rotated, any misalignment exerts a sideways force on the reamer as it is fed to depth, resulting in the formation of a tapered hole. This type of bellmouthing can frequently be reduced by shortening the bearing length of the cutting portion of the reamer. One way to do this is to reduce the reamer diameter by 0.010 to 0.030 inch, depending on size and length, behind a short full-diameter section,  $\frac{1}{8}$  to  $\frac{1}{2}$  inch long according to length and size, following the chamfer. The second method is to grind a high back taper, 0.008 to 0.015 inch per inch, behind the short full-diameter section. Either of these modifications reduces the length of the reamer tooth that can cause the bellmouth condition.

**Poor Finish:** The most obvious step toward producing a good finish is to reduce the reamer feed per revolution. Feeds as low as 0.0002 to 0.0005 inch per tooth have been used successfully. However, reamer life will be better if the maximum feasible feed is used.

The minimum practical amount of reaming stock allowance will often improve finish by reducing the volume of chips and the resulting heat generated on the cutting portion of the chamfer. Too little reamer stock, however, can be troublesome in that the reamer teeth may not cut freely but will deflect or push the work material out of the way. When this happens, excessive heat, poor finish, and rapid reamer wear can occur.

Because of their superior abrasion resistance, carbide reamers are often used when fine finishes are required. When properly conditioned, carbide reamers can produce a large number of good-quality holes. Careful honing of the carbide reamer edges is very important.

\*"Some Aspects of Reamer Design and Operation," *Metal Cuttings*, April 1963.

Dimensions of Centers for Reamers and Arbors

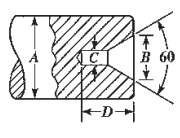

Arbor Dia. A	Large Center Dia. B	Drill No. C	Hole Depth D	Arbor Dia. A	Large Center Dia. B	Drill No. C	Hole Depth D
3/4	3/8	25	3/8	2 1/2	1 1/16	J	2 1/16
1 1/8	1/2	20	1/2	2 3/4	4/16	K	3/4
1 1/4	5/8	17	17/32	2 7/8	2 3/16	L	2 3/16
1 1/2	3/4	12	3/8	2 7/8	4/16	M	2 3/16
1 3/4	7/8	8	1/2	3	3/4	N	1 3/8
1 7/8	1 1/8	5	5/8	3 1/8	4/16	N	3 1/8
2	1 1/4	3	3/4	3 1/4	3 3/16	O	3 1/4
2 1/8	1 3/8	2	7/8	3 3/8	3 1/4	O	1
2 1/4	1 1/2	1	1 1/8	3 1/2	3 1/8	P	1
2 1/2	1 5/8	Letter	1 1/4	3 5/8	3 1/4	Q	1 1/4
2 3/4	1 3/4	A	1 1/2	3 3/4	3 1/4	R	1 1/4
3	1 7/8	B	1 3/4	3 3/4	3 1/4	R	1 1/4
3 1/4	2	C	1 7/8	4	3/8	S	1 1/8
3 1/2	2 1/8	E	2	4 1/4	2 3/16	T	1 1/4
3 3/4	2 1/4	F	2 1/8	4 1/2	3/16	V	1 3/8
4	2 1/2	G	2 1/4	4 3/4	3/16	W	1 1/4
4 1/4	2 3/4	H	2 3/8	5	1	X	1 1/4

Straight Shank Center Reamers and Machine Countersinks  
ANSI B94.2-1983, R1988

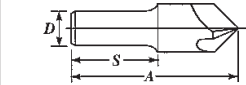
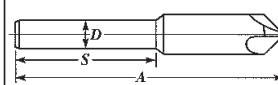
Center Reamers (Short Countersinks)				Machine Countersinks			
Dia. of Cut	Approx. Length Overall A	Length of Shank S	Dia. of Shank D	Dia. of Cut	Approx. Length Overall A	Length of Shank S	Dia. of Shank D
1/4	1 1/2	3/4	3/16	1/2	3 3/8	2 1/4	1/2
3/8	1 3/4	7/8	1/4	3/8	4	2 1/4	1/2
1/2	2	1	3/8	3/4	4 1/8	2 1/4	1/2
5/8	2 1/4	1	1/2	7/8	4 1/4	2 1/4	1/2
3/4	2 3/8	1 1/4	5/8	1	4 3/8	2 1/4	1/2

All dimensions are given in inches. Material is high-speed steel. Reamers and countersinks have 3 or 4 flutes. Center reamers are standard with 60, 82, 90, or 100 degrees included angle. Machine countersinks are standard with either 60 or 82 degrees included angle.

Tolerances: On overall length A, the tolerance is ±1/16 inch for center reamers in a size range of from 1/4 to 3/8 inch, incl., and machine countersinks in a size range of from 1/2 to 3/8 inch, incl.; ±3/16 inch for center reamers, 1/2 to 3/4 inch, incl.; and machine countersinks, 3/4 to 1 inch, incl. On shank diameter D, the tolerance is -0.0005 to -0.002 inch. On shank length S, the tolerance is ±1/16 inch.



Expansion Chucking Reamers—Straight and Taper Shanks  
ANSI B94.2-1983, R1988

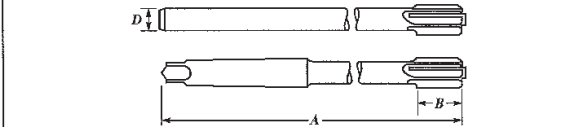

Dia. of Reamer	Length, A	Flute Length, B	Shank Dia., D		Dia. of Reamer	Length, A	Flute Length, B	Shank Dia., D	
			Max.	Min.				Max.	Min.
3/8	7	3/4	0.3105	0.3095	1 1/2	10 1/2	1 1/2	0.8745	0.8730
1/2	7	3/4	0.3105	0.3095	1 1/2	11	1 1/2	0.8745	0.8730
5/8	7	3/4	0.3730	0.3720	1 3/8	11	1 1/2	0.8745	0.8730
15/16	7	3/4	0.3730	0.3720	1 3/8	11	1 1/2	0.9995	0.9980
1/2	8	1	0.4355	0.4345	1 7/8	11	1 1/2	0.9995	0.9980
5/8	8	1	0.4355	0.4345	1 7/8	11 1/2	1 3/4	0.9995	0.9980
3/4	8	1 1/4	0.4355	0.4345	1 3/4	11 1/2	1 3/4	0.9995	0.9980
7/8	8	1 1/4	0.4355	0.4345	1 3/4	12	2	0.9995	0.9980
1 1/16	9	1 1/2	0.5620	0.5605	1 5/8	12	2	1.2495	1.2480
1 1/8	9	1 1/2	0.5620	0.5605	1 5/8	12 1/2	2 1/4	1.2495	1.2480
1 1/4	9	1 3/4	0.5620	0.5605	1 5/8	12 1/2	2 1/4	1.2495	1.2480
1 1/2	9	1 3/4	0.5620	0.5605	1 5/8	13	2 1/4	1.2495	1.2480
1 3/8	9 1/2	1 3/4	0.6245	0.6230	1 11/8	13	2 1/2	1.2495	1.2480
1 1/2	9 1/2	1 3/4	0.6245	0.6230	1 3/4	13 1/2	2 3/4	1.2495	1.2480
1 5/8	9 1/2	1 3/4	0.6245	0.6230	1 11/8	13 1/2	2 3/4	1.4995	1.4980
1 7/8	9 1/2	1 3/4	0.6245	0.6230	1 3/4	14	2 1/2	1.4995	1.4980
2	10	1 1/2	0.7495	0.7480	1 13/8	14	2 1/2	1.4995	1.4980
2 1/16	10	1 1/2	0.7495	0.7480	2	14	2 1/2	1.4995	1.4980
2 1/8	10	1 1/2	0.7495	0.7480	2 1/8	14 1/2	2 3/4	...	...
2 1/4	10	1 1/2	0.7495	0.7480	2 1/8	14 1/2	2 3/4	...	...
1	10 1/2	1 3/4	0.8745	0.8730	2 3/8	15	3	...	...
1 1/4	10 1/2	1 3/4	0.8745	0.8730	2 3/8	15	3	...	...
1 1/2	10 1/2	1 3/4	0.8745	0.8730	...	...	...	...	...

<sup>a</sup> Straight shank only.  
<sup>b</sup> Taper shank only.

All dimensions in inches. Material is high-speed steel. The number of flutes is as follows: 3/8- to 1 1/2-inch sizes, 4 to 6; 1/2- to 3/16-inch sizes, 6 to 8; 1- to 1 1/16-inch sizes, 8 to 10; 1 1/2- to 1 1/16-inch sizes, 8 to 12; 2- to 2 1/4-inch sizes, 10 to 12; 2 3/8- and 2 1/2-inch sizes, 10 to 14. The expansion feature of these reamers provides a means of adjustment that is important in reaming holes to close tolerances. When worn undersize, they may be expanded and reground to the original size.

**Tolerances:** On reamer diameter, 3/8- to 1-inch sizes, incl., +0.0001 to -0.0005 inch; over 1-inch size, +0.0002 to +0.0006 inch. On length A and flute length B, 3/8- to 1-inch sizes, incl., ±1/16 inch; 1 1/2- to 2-inch sizes, incl., ±3/32 inch; over 2-inch sizes, ±1/8 inch.

Taper is Morse taper: No. 1 for sizes 3/8 to 1 1/2 inch, incl.; No. 2 for sizes 1/2 to 2 1/2 inch, incl.; No. 3 for sizes 1 1/2 to 1 1/2 inch, incl.; No. 4 for sizes 1 1/4 to 1 1/2 inch, incl.; and No. 5 for sizes 1 1/2 to 2 1/2 inch, incl. For amount of taper, see Table 1b on page 908.

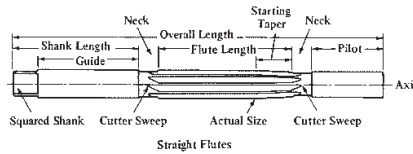

Hand Reamer, Pilot and Guide

Illustration of Terms Applying to Reamers—1

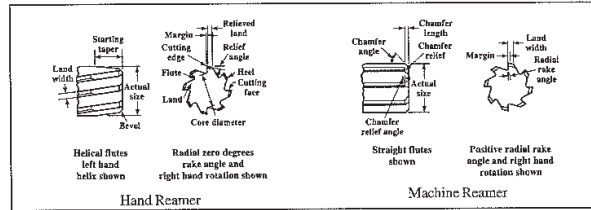
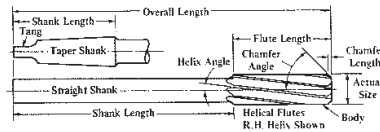

Illustration of Terms Applying to Reamers—2



American National Standard Fluted Taper Shank Chucking Reamers—  
Straight and Helical Flutes, Fractional Sizes ANSI B94.2-1983, R1988

Reamer Dia.	Length Overall A	Flute Length B	No. of Morse Taper Shank <sup>a</sup>	No. of Flutes	Reamer Dia.	Length Overall A	Flute Length B	No. of Morse Taper Shank <sup>a</sup>	No. of Flutes
1/4	6	1 1/2	1	4 to 6	7/16	9 1/2	2 1/2	2	8 to 10
5/16	6	1 1/2	1	4 to 6	1/2	10	2 3/4	2	8 to 10
3/8	7	1 3/4	1	4 to 6	5/8	10	2 3/4	2	8 to 10
7/16	7	1 3/4	1	6 to 8	3/4	10	2 3/4	3	8 to 10
1/2	8	2	1	6 to 8	7/8	10 1/2	2 3/4	3	8 to 10
5/8	8	2	1	6 to 8	1 1/8	10 1/2	2 3/4	3	8 to 12
3/4	8	2	1	6 to 8	1 1/4	11	2 3/4	3	8 to 12
7/8	8	2	1	6 to 8	1 1/2	11	2 3/4	3	8 to 12
1 1/8	9	2 1/2	2	6 to 8	1 3/8	11 1/2	3	4	8 to 12
1 1/4	9	2 1/2	2	6 to 8	1 1/2	11 1/2	3	4	8 to 12
1 1/2	9	2 1/2	2	6 to 8	1 5/8	11 1/2	3	4	8 to 12
1 3/4	9	2 1/2	2	6 to 8	1 3/4	12	3 1/4	4	10 to 12
1 7/8	9 1/2	2 1/2	2	6 to 8	1 7/8	12	3 1/4	4	10 to 12
2	9 1/2	2 1/2	2	8 to 10	2	12 1/2	3 1/2	4	10 to 12
2 1/8	9 1/2	2 1/2	2	8 to 10	...	...	...	...	...

<sup>a</sup>American National Standard self-holding tapers (see Table 7a on page 913.)

All dimensions are given in inches. Material is high-speed steel.

Helical flute reamers with right-hand helical flutes are standard.

Tolerances: On reamer diameter, 1/4-inch size, +.0001 to +.0004 inch; over 1/4 to 1-inch size, +.0001 to +.0005 inch; over 1-inch size, +.0002 to +.0006 inch. On length overall A and flute length B, 1/4- to 1-inch size, incl., ±.0006 inch; 1 1/8- to 1 1/2-inch size, incl., ±.0007 inch.

Hand Reamers—Straight and Helical Flutes ANSI B94.2-1983, R1988

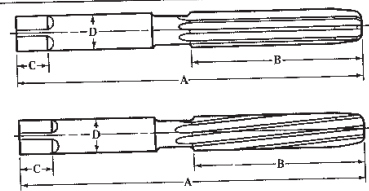

Reamer Diameter			Length Overall A	Flute Length B	Square Length C	Size of Square	No. of Flutes
Straight Flutes	Helical Flutes	Decimal Equivalent					
1/8	...	0.1250	3	1 1/2	5/16	0.095	4 to 6
5/32	...	0.1562	3 1/4	1 3/4	3/16	0.115	4 to 6
3/16	...	0.1875	3 1/2	1 3/4	5/16	0.140	4 to 6
1/4	...	0.2188	3 3/4	1 3/4	1/4	0.165	4 to 6
5/16	...	0.2500	4	2	1/4	0.185	4 to 6
3/8	...	0.2812	4 1/4	2 1/4	1/4	0.210	4 to 6
7/16	...	0.3125	4 1/2	2 1/4	3/16	0.235	4 to 6
1/2	...	0.3438	4 3/4	2 3/4	1/4	0.255	4 to 6
5/8	...	0.3750	5	2 1/2	3/8	0.280	4 to 6
3/4	...	0.4062	5 1/4	2 5/8	1/2	0.305	6 to 8
7/8	...	0.4375	5 1/2	2 3/4	3/8	0.330	6 to 8
1 1/8	...	0.4688	5 3/4	2 7/8	1/2	0.350	6 to 8
1 1/4	...	0.5000	6	3	1/2	0.375	6 to 8
1 1/2	...	0.5312	6 1/4	3 1/8	1/2	0.400	6 to 8
1 3/4	...	0.5625	6 1/2	3 1/4	3/8	0.420	6 to 8
2	...	0.5938	6 3/4	3 3/8	3/8	0.445	6 to 8
2 1/8	...	0.6250	7	3 1/2	3/8	0.470	6 to 8
2 1/4	...	0.6562	7 1/4	3 3/8	3/8	0.490	6 to 8
2 1/2	...	0.6875	7 1/2	3 3/4	1/2	0.515	6 to 8
2 3/4	...	0.7188	7 3/4	4 1/8	1/2	0.540	6 to 8
3	...	0.7500	8 1/4	4 1/4	3/4	0.560	6 to 8
3 1/8	...	0.8125	8 3/4	4 3/8	1/2	0.610	8 to 10
3 1/4	...	0.8750	9 1/4	4 3/4	3/4	0.655	8 to 10
3 1/2	...	0.9375	10 1/4	5 1/8	3/4	0.705	8 to 10
4	...	1.0000	10 3/4	5 3/8	1	0.750	8 to 10
4 1/8	...	1.1250	11 1/4	5 3/4	1	0.845	8 to 10
4 1/4	...	1.2500	12 1/4	6 1/4	1	0.935	8 to 12
4 1/2	...	1.3750	12 3/4	6 3/4	1	1.050	10 to 12
4 3/4	...	1.5000	13	6 3/4	1 1/4	1.125	10 to 14

All dimensions in inches. Material is high-speed steel. The nominal shank diameter *D* is the same as the reamer diameter. Helical-flute hand reamers with left-hand helical flutes are standard. Reamers are tapered slightly on the end to facilitate proper starting.

**Tolerances:** On diameter of reamer, up to 1/2-inch size, incl., +.0001 to +.0004 inch; over 1/2 to 1-inch size, incl., +.0001 to +.0005 inch; over 1-inch size, +.0002 to +.0006 inch. On length overall *A* and flute length *B*, 1/8 to 1-inch size, incl., ±1/16 inch; 1 1/8 to 1 1/2-inch size, incl., ±1/32 inch. On length of square *C*, 1/8 to 1-inch size, incl., ±1/32 inch; 1 1/8 to 1 1/2-inch size, incl., ±1/64 inch. On shank diameter *D*, 1/8 to 1-inch size, incl., -.001 to -.005 inch; 1 1/8 to 1 1/2-inch size, incl., -.0015 to -.006 inch. On size of square, 1/8 to 1/2-inch size, incl., -.004 inch; 1/32 to 1-inch size, incl., -.006 inch; 1 1/8 to 1 1/2-inch size, incl., -.008 inch.

American National Standard Expansion Hand Reamers—Straight and Helical Flutes, Squared Shank ANSI B94.2-1983, R1988

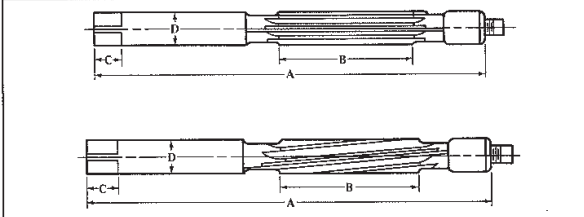

Reamer Dia.	Length Overall A		Flute Length B		Length of Square C	Shank Dia. D	Size of Square	Number of Flutes
	Max	Min	Max	Min				
Straight Flutes								
1/4	4 3/4	3 3/4	1 1/2	1 1/2	1/2	1/4	0.185	6 to 8
3/8	4 3/4	4	1 3/4	1 1/2	3/8	3/8	0.235	6 to 8
1/2	5 3/8	4 1/2	2	1 3/4	3/8	3/8	0.280	6 to 9
5/8	5 3/8	4 1/2	2	1 3/4	3/8	3/8	0.330	6 to 9
3/4	6 1/2	5	2 1/2	1 3/4	1/2	1/2	0.375	6 to 9
7/8	6 1/2	5 3/8	2 1/2	1 3/4	3/8	3/8	0.420	6 to 9
1	7	5 3/4	3	2 1/4	3/8	3/8	0.470	6 to 9
1 1/16	7 3/4	6 1/4	3	2 1/2	1/2	1/2	0.515	6 to 10
1 1/8	8	6 1/2	3 1/2	2 3/8	3/4	3/4	0.560	6 to 10
1 1/4	9	7 1/2	4	3 1/8	7/8	7/8	0.655	8 to 10
1 1/2	10	8 3/8	4 1/2	3 3/8	1	1	0.750	8 to 10
1 3/4	10 1/2	9	4 3/4	3 1/2	1	1 1/4	0.845	8 to 12
2	11	9 3/4	5	4 1/4	1	1 1/4	0.935	8 to 12
Helical Flutes								
1/4	4 3/4	3 3/4	1 3/4	1 1/2	1/2	1/4	0.185	6 to 8
3/8	4 3/4	4	1 3/4	1 1/2	3/8	3/8	0.235	6 to 8
1/2	6 1/4	4 1/2	2	1 3/4	3/8	3/8	0.280	6 to 9
5/8	6 1/4	4 1/2	2	1 3/4	3/8	3/8	0.330	6 to 9
3/4	6 1/2	5	2 1/2	1 3/4	1/2	1/2	0.375	6 to 9
7/8	6 1/2	5 3/8	2 1/2	1 3/4	3/8	3/8	0.470	6 to 9
1	8	6	3	2 1/4	3/8	3/8	0.470	6 to 9
1 1/16	8 3/8	6 1/2	3 1/2	2 3/8	3/8	3/8	0.560	6 to 10
1 1/8	9 3/8	7 1/2	4	3 1/8	7/8	7/8	0.655	6 to 10
1 1/4	10 1/4	8 3/8	4 1/2	3 3/8	1	1	0.750	6 to 10
1 1/2	11 1/2	9 3/4	5	4 1/4	1	1 1/4	0.935	8 to 12

All dimensions are given in inches. Material is carbon steel. Reamers with helical flutes that are left hand are standard. Expansion hand reamers are primarily designed for work where it is necessary to enlarge reamed holes by a few thousandths. The pilots and guides on these reamers are ground under-size for clearance. The maximum expansion on these reamers is as follows: .006 inch for the 1/4 to 3/8-inch sizes, .010 inch for the 1/2 to 3/4-inch sizes and .012 inch for the 1- to 1 1/4-inch sizes.

Tolerances: On length overall A and flute length B, ±1/16 inch for 1/4- to 1-inch sizes, ±3/32 inch for 1 1/8- to 1 1/2-inch sizes; on length of square C, ±1/32 inch for 1/4- to 1-inch sizes, ±1/16 inch for 1 1/8- to 1 1/4-inch sizes; on shank diameter D, -.001 to -.005 inch for 1/4- to 1-inch sizes, -.0015 to -.006 inch for 1 1/8- to 1 1/4-inch sizes; on size of square, -.004 inch for 1/4- to 1/2-inch sizes, -.006 inch for 3/8- to 1-inch sizes, and -.008 inch for 1 1/8- to 1 1/4-inch sizes.

Taper Shank Jobbers Reamers—Straight Flutes ANSI B94.2-1983, R1988

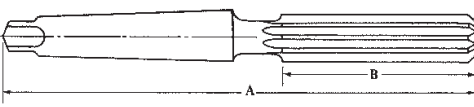

Reamer Diameter		Length Overall A	Length of Flute B	No. of Morse Taper Shanks*	No. of Flutes
Fractional	Dec. Equiv.				
1/8	0.2500	5 5/16	2	1	6 to 8
5/32	0.3125	5 1/2	2 1/4	1	6 to 8
3/16	0.3750	5 5/8	2 1/4	1	6 to 8
1/4	0.4375	6 1/8	2 3/4	1	6 to 8
5/16	0.5000	6 3/8	3	1	6 to 8
3/8	0.5625	6 7/8	3 1/4	1	6 to 8
7/16	0.6250	7 1/8	3 1/2	2	6 to 8
1/2	0.6875	8	3 3/4	2	8 to 10
9/16	0.7500	8 1/2	4 1/8	2	8 to 10
5/8	0.8125	8 5/8	4 1/8	2	8 to 10
11/16	0.8750	9 1/8	4 3/8	2	8 to 10
3/4	0.9375	10	5 1/8	3	8 to 10
1	1.0000	10 3/8	5 1/2	3	8 to 10
1 1/16	1.0625	10 3/8	5 5/8	3	8 to 10
1 1/8	1.1250	10 3/8	5 3/4	3	8 to 10
1 1/4	1.1875	11 1/8	6	3	8 to 12
1 3/8	1.2500	12 3/16	6 1/2	4	8 to 12
1 1/2	1.3750	12 3/8	6 3/4	4	10 to 12
1 5/8	1.5000	13 3/8	6 3/4	4	10 to 12

\* American National Standard self-holding tapers (Table 7a on page 913.)

All dimensions in inches. Material is high-speed steel.

Tolerances: On reamer diameter, 1/8-inch size, +.0001 to +.0004 inch; over 1/8- to 1-inch size, incl., +.0001 to +.0005 inch; over 1-inch size, +.0002 to +.0006 inch. On overall length A and length of flute B, 1/8- to 1-inch size, incl., ±1/16 inch; and 1 1/8- to 1 1/2-inch size, incl., ±3/32 inch.

American National Standard Driving Slots and Lugs for Shell Reamers or Shell Reamer Arbors ANSI B94.2-1983, R1988

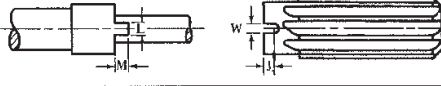

Arbor Size No.	Fitting Reamer Sizes	Driving Slot		Lug on Arbor		Reamer Hole Dia. at Large End
		Width W	Depth J	Width L	Depth M	
4	3/8	3/32	3/16	3/64	5/32	0.375
5	13/16 to 1	3/16	1/4	11/64	7/32	0.500
6	1 1/16 to 1 1/4	3/16	1/4	11/64	7/32	0.625
7	1 1/16 to 1 3/8	1/4	5/16	15/64	9/32	0.750
8	1 1/16 to 2	1/4	5/16	15/64	9/32	1.000
9	2 1/16 to 2 1/2	3/16	3/8	8/64	11/32	1.250

All dimension are given in inches. The hole in shell reamers has a taper of 1/8 inch per foot, with arbors tapered to correspond. Shell reamer arbor tapers are made to permit a driving fit with the reamer.

**Straight Shank Chucking Reamers—Straight Flutes, Wire Gage Sizes**  
ANSI B94.2-1983, R1988

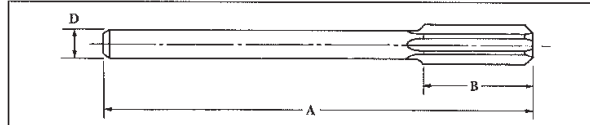

Reamer Diameter Wire Gage	Reamer Diameter Inch	Lgh. Over- all A	Lgh. of Flute B	Shank Dia. D		No. of Flutes	Reamer Diameter Wire Gage	Reamer Diameter Inch	Lgh. Over- all A	Lgh. of Flute B	Shank Dia. D		No. of Flutes
				Max	Min						Max	Min	
60	.0430	2½	½	.0390	.0380	4	49	.0730	3	¾	.0660	.0650	4
59	.0410	2½	½	.0390	.0380	4	48	.0760	3	¾	.0720	.0710	4
58	.0420	2½	½	.0390	.0380	4	47	.0785	3	¾	.0720	.0710	4
57	.0430	2½	½	.0390	.0380	4	46	.0810	3	¾	.0771	.0761	4
56	.0465	2½	½	.0455	.0445	4	45	.0820	3	¾	.0771	.0761	4
55	.0520	2½	½	.0510	.0500	4	44	.0860	3	¾	.0810	.0800	4
54	.0550	2½	½	.0510	.0500	4	43	.0890	3	¾	.0810	.0800	4
53	.0595	2½	½	.0585	.0575	4	42	.0935	3	¾	.0880	.0870	4
52	.0635	2½	½	.0585	.0575	4	41	.0960	3½	¾	.0928	.0918	4 to 6
51	.0670	3	½	.0660	.0650	4	40	.0980	3½	¾	.0928	.0918	4 to 6
50	.0700	3	½	.0660	.0650	4	39	.0995	3½	¾	.0928	.0918	4 to 6
58	.1015	3½	¾	.0950	.0940	4 to 6	19	.1660	4½	1½	.1595	.1585	4 to 6
57	.1040	3½	¾	.0950	.0940	4 to 6	18	.1695	4½	1½	.1595	.1585	4 to 6
36	.1065	3½	¾	.1030	.1020	4 to 6	17	.1730	4½	1½	.1645	.1635	4 to 6
35	.1100	3½	¾	.1030	.1020	4 to 6	16	.1770	4½	1½	.1704	.1694	4 to 6
34	.1110	3½	¾	.1055	.1045	4 to 6	15	.1800	4½	1½	.1755	.1745	4 to 6
33	.1130	3½	¾	.1055	.1045	4 to 6	14	.1820	4½	1½	.1755	.1745	4 to 6
32	.1160	3½	¾	.1120	.1110	4 to 6	13	.1850	4½	1½	.1805	.1795	4 to 6
31	.1200	3½	¾	.1120	.1110	4 to 6	12	.1890	4½	1½	.1805	.1795	4 to 6
30	.1285	3½	¾	.1190	.1180	4 to 6	11	.1910	5	1½	.1860	.1850	4 to 6
29	.1360	4	1	.1275	.1265	4 to 6	10	.1935	5	1½	.1860	.1850	4 to 6
28	.1405	4	1	.1250	.1240	4 to 6	9	.1960	5	1½	.1895	.1885	4 to 6
27	.1440	4	1	.1250	.1240	4 to 6	8	.1990	5	1½	.1895	.1885	4 to 6
26	.1470	4	1	.1430	.1420	4 to 6	7	.2010	5	1½	.1945	.1935	4 to 6
25	.1495	4	1	.1430	.1420	4 to 6	6	.2040	5	1½	.1945	.1935	4 to 6
24	.1520	4	1	.1460	.1450	4 to 6	5	.2055	5	1½	.2016	.2006	4 to 6
23	.1540	4	1	.1460	.1450	4 to 6	4	.2090	5	1½	.2016	.2006	4 to 6
22	.1570	4	1	.1510	.1500	4 to 6	3	.2130	5	1½	.2075	.2065	4 to 6
21	.1590	4½	1½	.1530	.1520	4 to 6	2	.2210	6	1½	.2173	.2163	4 to 6
20	.1610	4½	1½	.1530	.1520	4 to 6	1	.2280	6	1½	.2173	.2163	4 to 6

All dimensions in inches. Material is high-speed steel.

Tolerances: On diameter of reamer, plus .0001 to plus .0004 inch. On overall length A, plus or minus ½ inch. On length of flute B, plus or minus ½ inch.

**Straight Shank Chucking Reamers—Straight Flutes, Letter Sizes**  
ANSI B94.2-1983, R1988



Reamer Diameter Letter	Inch	Lgth. Overall A	Lgth. of Flute B	Shank Dia. D		No. of Flutes	Reamer Diameter Letter	Inch	Lgth. Overall A	Lgth. of Flute B	Shank Dia. D		No. of Flutes
				Max.	Min.						Max.	Min.	
A	0.2340	6	1 1/2	0.2265	.2255	4 to 6	N	0.3020	6	1 1/2	0.2792	0.2782	4 to 6
B	0.2380	6	1 1/2	0.2329	.2319	4 to 6	O	0.3160	6	1 1/2	0.2792	0.2782	4 to 6
C	0.2420	6	1 1/2	0.2329	.2319	4 to 6	P	0.3330	6	1 1/2	0.2792	0.2782	4 to 6
D	0.2460	6	1 1/2	0.2329	.2319	4 to 6	Q	0.3320	6	1 1/2	0.2792	0.2782	4 to 6
E	0.2500	6	1 1/2	0.2405	.2395	4 to 6	R	0.3390	6	1 1/2	0.2792	0.2782	4 to 6
F	0.2570	6	1 1/2	0.2485	.2475	4 to 6	S	0.3480	7	1 3/4	0.3105	0.3095	4 to 6
G	0.2610	6	1 1/2	0.2485	.2475	4 to 6	T	0.3580	7	1 3/4	0.3105	0.3095	4 to 6
H	0.2660	6	1 1/2	0.2485	.2475	4 to 6	U	0.3680	7	1 3/4	0.3105	0.3095	4 to 6
I	0.2720	6	1 1/2	0.2485	.2475	4 to 6	V	0.3770	7	1 3/4	0.3105	0.3095	4 to 6
J	0.2770	6	1 1/2	0.2485	.2475	4 to 6	W	0.3860	7	1 3/4	0.3105	0.3095	4 to 6
K	0.2810	6	1 1/2	0.2485	.2475	4 to 6	X	0.3970	7	1 3/4	0.3105	0.3095	4 to 6
L	0.2900	6	1 1/2	0.2792	.2782	4 to 6	Y	0.4040	7	1 1/2	0.3105	0.3095	4 to 6
M	0.2950	6	1 1/2	0.2792	.2782	4 to 6	Z	0.4130	7	1 1/2	0.3730	0.3720	6 to 8

All dimensions in inches. Material is high-speed steel.

Tolerances: On diameter of reamer, for sizes A to E, incl., plus .0001 to plus .0004 inch and for sizes F to Z, incl., plus .0001 to plus .0005 inch. On overall length A, plus or minus 1/16 inch. On length of flute B, plus or minus 1/16 inch.

**Straight Shank Chucking Reamers—Straight Flutes, Decimal Sizes**  
ANSI B94.2-1983, R1988



Reamer Dia.	Lgth. Overall A	Lgth. of Flute B	Shank Diameter D		No. of Flutes	Reamer Dia.	Lgth. Overall A	Lgth. of Flute B	Shank Diameter D		No. of Flutes
			Max.	Min.					Max.	Min.	
0.1240	3 1/2	3/4	0.1190	0.1180	4 to 6	0.3135	6	1 1/2	0.2792	0.2782	4 to 6
0.1260	3 1/2	3/4	0.1190	0.1180	4 to 6	0.3740	7	1 1/2	0.3105	0.3095	6 to 8
0.1865	4 1/2	1 1/4	0.1805	0.1795	4 to 6	0.3760	7	1 1/2	0.3105	0.3095	6 to 8
0.1885	4 1/2	1 1/4	0.1805	0.1795	4 to 6	0.4365	7	1 3/4	0.3730	0.3720	6 to 8
0.2490	6	1 1/2	0.2405	0.2395	4 to 6	0.4385	7	1 3/4	0.3730	0.3720	6 to 8
0.2510	6	1 1/2	0.2405	0.2395	4 to 6	0.4990	8	2	0.4355	0.4345	6 to 8
0.3115	6	1 1/2	0.2792	0.2782	4 to 6	0.5010	8	2	0.4355	0.4345	6 to 8

All dimensions in inches. Material is high-speed steel.

Tolerances: On diameter of reamer, for 0.124 to 0.249-inch sizes, plus .0001 to plus .0004 inch and for 0.251 to 0.501-inch sizes, plus .0001 to plus .0005 inch. On overall length A, plus or minus 1/16 inch. On length of flute B, plus or minus 1/16 inch.

American National Standard Straight Shank Rose Chucking and Chucking  
Reamers—Straight and Helical Flutes, Fractional Sizes ANSI B94.2-1983 (R1988)

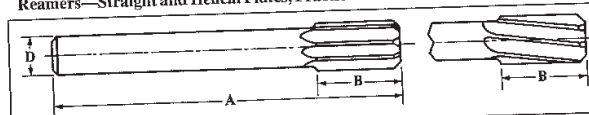

Reamer Diameter		Length Overall A	Flute Length B	Shank Dia. D		No. of Flutes
Chucking	Rose Chucking			Max	Min	
3/16	...	2 1/2	1/2	0.0455	0.0445	4
1/8	...	2 1/2	1/2	0.0585	0.0575	4
5/16	...	3	3/4	0.0720	0.0710	4
3/8	...	3	3/4	0.0850	0.0870	4
7/16	...	3 1/2	3/4	0.1030	0.1020	4 to 6
1/2	...	3 1/2	3/4	0.1190	0.1180	4 to 6
9/16	...	4	1	0.1350	0.1340	4 to 6
5/8	...	4	1	0.1510	0.1500	4 to 6
11/16	...	4 1/2	1 1/4	0.1645	0.1635	4 to 6
3/4	...	4 1/2	1 1/4	0.1805	0.1795	4 to 6
13/16	...	5	1 1/2	0.1945	0.1935	4 to 6
7/8	...	5	1 1/2	0.2075	0.2065	4 to 6
15/16	...	6	1 3/4	0.2265	0.2255	4 to 6
1	...	6	1 3/4	0.2405	0.2395	4 to 6
1 1/16	...	6	1 3/4	0.2485	0.2475	4 to 6
1 1/8	...	6	1 3/4	0.2792	0.2782	4 to 6
1 1/4	...	6	1 3/4	0.2792	0.2782	4 to 6
1 1/2	...	6	1 3/4	0.2792	0.2782	4 to 6
1 3/8	...	6	1 3/4	0.2792	0.2782	4 to 6
1 7/16	...	6	1 3/4	0.2792	0.2782	4 to 6
1 1/2	...	6	1 3/4	0.2792	0.2782	4 to 6
1 9/16	...	7	1 3/4	0.3105	0.3095	4 to 6
1 5/8	...	7	1 3/4	0.3105	0.3095	4 to 6
1 11/16	...	7	1 3/4	0.3105	0.3095	4 to 6
1 3/4	...	7	1 3/4	0.3730	0.3720	6 to 8
1 7/8	...	7	1 3/4	0.3730	0.3720	6 to 8
1 15/16	...	7	1 3/4	0.3730	0.3720	6 to 8
2	...	7	1 3/4	0.3730	0.3720	6 to 8
2 1/16	...	8	2	0.4355	0.4345	6 to 8
2 1/8	...	8	2	0.4355	0.4345	6 to 8
2 1/4	...	8	2	0.4355	0.4345	6 to 8
2 3/8	...	8	2	0.4355	0.4345	6 to 8
2 1/2	...	8	2	0.4355	0.4345	6 to 8
2 5/8	...	9	2 1/4	0.5620	0.5605	6 to 8
2 3/4	...	9	2 1/4	0.5620	0.5605	6 to 8
2 7/8	...	9	2 1/4	0.5620	0.5605	6 to 8
3	...	9	2 1/4	0.5620	0.5605	6 to 8
3 1/16	...	9 1/2	2 1/2	0.6245	0.6230	8 to 10
3 1/8	...	9 1/2	2 1/2	0.6245	0.6230	8 to 10
3 1/4	...	9 1/2	2 1/2	0.6245	0.6230	8 to 10
3 3/8	...	10	2 3/4	0.7495	0.7480	8 to 10
3 1/2	...	10	2 3/4	0.7495	0.7480	8 to 10
3 5/8	...	10	2 3/4	0.7495	0.7480	8 to 10
3 3/4	...	10	2 3/4	0.7495	0.7480	8 to 10
4	...	10 1/2	2 3/4	0.8745	0.8730	8 to 12
4 1/8	...	11	2 3/4	0.8745	0.8730	8 to 12
4 1/4	...	11	2 3/4	0.8745	0.8730	8 to 12
4 3/8	...	11 1/2	3	0.9995	0.9980	8 to 12
4 1/2	...	11 1/2	3	0.9995	0.9980	8 to 12
4 5/8	...	12	3 1/4	0.9995	0.9980	10 to 12
4 3/4	...	12	3 1/4	1.2495	1.2480	10 to 12
5	...	12 1/2	3 1/2	1.2495	1.2480	10 to 12



<sup>a</sup>Reamer with straight flutes is standard only.

<sup>b</sup>Reamer with helical flutes is standard only.

All dimensions are given in inches. Material is high-speed steel. Chucking reamers are end cutting on the chamfer and the relief for the outside diameter is ground in back of the margin for the full length of land. Lands of rose chucking reamers are not relieved on the periphery but have a relatively large amount of back taper.

**Tolerances:** On reamer diameter, up to  $\frac{1}{8}$ -inch size, incl., +.0001 to +.0004 inch; over  $\frac{1}{8}$ -to 1-inch size, incl., +.0001 to +.0005 inch; over 1-inch size, +.0002 to +.0006 inch. On length overall *A* and flute length *B*, up to 1-inch size, incl.,  $\pm\frac{1}{16}$  inch;  $1\frac{1}{16}$ -to  $1\frac{1}{2}$ -inch size, incl.,  $\pm\frac{1}{32}$  inch.

Helical flutes are right- or left-hand helix, right-hand cut, except sizes  $1\frac{1}{16}$  through  $1\frac{1}{2}$  inches, which are right-hand helix only.

#### Shell Reamers—Straight and Helical Flutes ANSI B94.2-1983, R1988

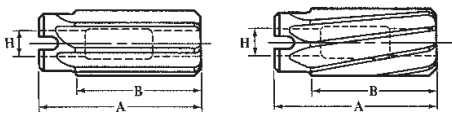

Diameter of Reamer	Length Overall <i>A</i>	Flute Length <i>B</i>	Hole Diameter Large End <i>H</i>	Fitting Arbor No.	Number of Flutes
$\frac{3}{8}$	2 $\frac{1}{2}$	1 $\frac{1}{2}$	0.375	4	8 to 10
$\frac{7}{8}$	2 $\frac{1}{2}$	1 $\frac{1}{2}$	0.500	5	8 to 10
$\frac{9}{16}$ <sup>a</sup>	2 $\frac{1}{2}$	1 $\frac{1}{2}$	0.500	5	8 to 10
1	2 $\frac{1}{2}$	1 $\frac{1}{2}$	0.500	5	8 to 10
$1\frac{1}{16}$	2 $\frac{1}{2}$	2	0.625	6	8 to 12
$1\frac{1}{4}$	2 $\frac{1}{2}$	2	0.625	6	8 to 12
$1\frac{3}{16}$	2 $\frac{1}{2}$	2	0.625	6	8 to 12
$1\frac{1}{2}$	2 $\frac{1}{2}$	2	0.625	6	8 to 12
$1\frac{5}{16}$	3	2 $\frac{1}{4}$	0.750	7	8 to 12
$1\frac{3}{4}$	3	2 $\frac{1}{4}$	0.750	7	8 to 12
$1\frac{7}{16}$	3	2 $\frac{1}{4}$	0.750	7	8 to 12
$1\frac{1}{2}$	3	2 $\frac{1}{4}$	0.750	7	10 to 14
$1\frac{9}{16}$	3	2 $\frac{1}{4}$	0.750	7	10 to 14
$1\frac{3}{4}$	3	2 $\frac{1}{4}$	0.750	7	10 to 14
$1\frac{5}{8}$	3 $\frac{1}{2}$	2 $\frac{1}{2}$	1.000	8	10 to 14
$1\frac{3}{4}$	3 $\frac{1}{2}$	2 $\frac{1}{2}$	1.000	8	12 to 14
$1\frac{7}{8}$	3 $\frac{1}{2}$	2 $\frac{1}{2}$	1.000	8	12 to 14
$1\frac{9}{8}$	3 $\frac{1}{2}$	2 $\frac{1}{2}$	1.000	8	12 to 14
2	3 $\frac{1}{2}$	2 $\frac{1}{2}$	1.000	8	12 to 14
$2\frac{1}{16}$ <sup>a</sup>	3 $\frac{1}{4}$	2 $\frac{1}{4}$	1.250	9	12 to 16
$2\frac{1}{4}$	3 $\frac{1}{4}$	2 $\frac{1}{4}$	1.250	9	12 to 16
$2\frac{3}{16}$ <sup>a</sup>	3 $\frac{1}{4}$	2 $\frac{1}{4}$	1.250	9	12 to 16
$2\frac{1}{2}$	3 $\frac{1}{4}$	2 $\frac{1}{4}$	1.250	9	12 to 16
$2\frac{3}{8}$ <sup>a</sup>	3 $\frac{1}{4}$	2 $\frac{1}{4}$	1.250	9	14 to 16
$2\frac{1}{2}$ <sup>a</sup>	3 $\frac{1}{4}$	2 $\frac{1}{4}$	1.250	9	14 to 16

<sup>a</sup>Helical flutes only.

All dimensions are given in inches. Material is high-speed steel. Helical flute shell reamers with left-hand helical flutes are standard. Shell reamers are designed as a sizing or finishing reamer and are held on an arbor provided with driving lugs. The holes in these reamers are ground with a taper of  $\frac{1}{16}$  inch per foot.

**Tolerances:** On diameter of reamer,  $\frac{3}{8}$ -to 1-inch size, incl.,  $\pm$ .0001 to +.0005 inch; over 1-inch size, +.0002 to +.0006 inch. On length overall *A* and flute length *B*,  $\frac{3}{8}$ -to 1-inch size, incl.,  $\pm\frac{1}{16}$  inch;  $1\frac{1}{16}$ -to 2-inch size, incl.,  $\pm\frac{1}{32}$  inch;  $2\frac{1}{16}$ -to  $2\frac{1}{2}$ -inch size, incl.,  $\pm\frac{1}{16}$  inch.

American National Standard Arbors for Shell Reamers—  
Straight and Taper Shanks ANSI B94.2-1983, R1988

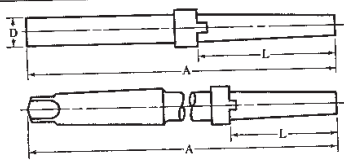

Arbor Size No.	Overall Length A	Approximate Length of Taper L	Reamer Size	Taper Shank No.*	Straight Shank Dia. D
4	9	2 1/4	3/4	2	1/2
5	9 1/2	2 1/2	9/16 to 1	2	5/8
6	10	2 3/4	1 1/16 to 1 1/2	3	3/4
7	11	3	1 1/8 to 1 3/4	3	7/8
8	12	3 1/2	1 1/2 to 2	4	1 1/8
9	13	3 3/4	2 1/16 to 2 1/2	4	1 1/4

\* American National Standard self-holding tapers (see Table 7a on page 913.)  
All dimensions are given in inches. These arbors are designed to fit standard shell reamers (see table). End which fits reamer has taper of 1/8 inch per foot.

Stub Screw Machine Reamers—Helical Flutes ANSI B94.2-1983, R1988

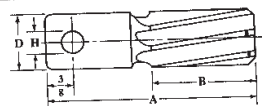

Series No.	Diameter Range	Length of Flute		Dia. of Shank D	Size of Hole H	Flute No.	Series No.	Diameter Range	Length of Flute		Dia. of Shank D	Size of Hole H	Flute No.
		A	B						A	B			
00	.0600-.066	1 1/2	1/2	1/2	1/16	4	12	.3761-.407	2 1/2	1 1/4	1/2	1/16	6
0	.0661-.074	1 3/4	1/2	1/2	1/16	4	13	.4071-.439	2 1/2	1 1/4	1/2	1/16	6
1	.0741-.084	1 3/4	1/2	1/2	1/16	4	14	.4391-.470	2 1/2	1 1/4	1/2	1/16	6
2	.0841-.096	1 3/4	1/2	1/2	1/16	4	15	.4701-.505	2 1/2	1 1/2	1/2	1/16	6
3	.0961-.126	2	3/4	1/2	1/16	4	16	.5051-.567	3	1 1/2	3/4	1/16	6
4	.1261-.158	2 1/4	1	1/2	1/16	4	17	.5671-.630	3	1 1/2	3/4	1/16	6
5	.1581-.188	2 1/4	1	1/2	1/16	4	18	.6301-.692	3	1 1/2	3/4	1/16	6
6	.1881-.219	2 1/4	1	1/2	1/16	6	19	.6921-.755	3	1 1/2	3/4	1/16	8
7	.2191-.251	2 1/2	1	1/2	1/16	6	20	.7551-.817	3	1 1/2	3/4	1/16	8
8	.2511-.282	2 1/2	1	1/2	1/16	6	21	.8171-.880	3	1 1/2	3/4	1/16	8
9	.2821-.313	2 1/2	1	1/2	1/16	6	22	.8801-.942	3	1 1/2	3/4	1/16	8
10	.3131-.344	2 1/2	1 1/4	3/4	1/16	6	23	.9421-1.010	3	1 1/2	3/4	1/16	8
11	.3441-.376	2 1/2	1 1/4	3/4	1/16	6	...	...	...	...	...	...	...

All dimensions in inches. Material is high-speed steel.  
These reamers are standard with right-hand cut and left-hand helical flutes within the size ranges shown.  
Tolerances: On diameter of reamer, for sizes 00 to 7, incl., plus .0001 to plus .0004 inch and for sizes 8 to 23, incl., plus .0001 to plus .0005 inch. On overall length A, plus or minus 1/16 inch. On length of flute B, plus or minus 1/32 inch. On diameter of shank D, minus .0005 to minus .002 inch.

**American National Standard Morse Taper Finishing Reamers**  
ANSI B94.2-1983, R1988

Straight Flutes and Squared Shank							
Taper No. <sup>a</sup>	Small End Dia. (Ref.)	Large End Dia. (Ref.)	Length Overall A	Flute Length B	Square Length C	Shank Dia. D	Square Size
0	0.2503	0.3674	3 $\frac{3}{4}$	2 $\frac{1}{4}$	$\frac{5}{16}$	$\frac{5}{16}$	0.235
1	0.3674	0.5170	5	3	$\frac{7}{16}$	$\frac{7}{16}$	0.330
2	0.5696	0.7444	6	3 $\frac{1}{2}$	$\frac{9}{16}$	$\frac{9}{16}$	0.470
3	0.7748	0.9881	7 $\frac{1}{4}$	4 $\frac{1}{4}$	$\frac{7}{8}$	$\frac{7}{8}$	0.655
4	1.0167	1.2893	8 $\frac{1}{2}$	5 $\frac{1}{4}$	1	1 $\frac{1}{8}$	0.845
5	1.4717	1.8005	9 $\frac{3}{4}$	6 $\frac{1}{4}$	1 $\frac{1}{8}$	1 $\frac{1}{2}$	1.125

Straight and Spiral Flutes and Taper Shank						Squared and Taper Shank
Taper No. <sup>a</sup>	Small End Dia. (Ref.)	Large End Dia. (Ref.)	Length Overall A	Flute Length B	Taper Shank No. <sup>a</sup>	Number of Flutes
0	0.2503	0.3674	5 $\frac{11}{32}$	2 $\frac{1}{4}$	0	4 to 6 incl.
1	0.3674	0.5170	6 $\frac{5}{16}$	3	1	6 to 8 incl.
2	0.5696	0.7444	7 $\frac{3}{8}$	3 $\frac{1}{2}$	2	6 to 8 incl.
3	0.7748	0.9881	8 $\frac{7}{8}$	4 $\frac{1}{4}$	3	8 to 10 incl.
4	1.0167	1.2893	10 $\frac{7}{8}$	5 $\frac{1}{4}$	4	8 to 10 incl.
5	1.4717	1.8005	13 $\frac{1}{8}$	6 $\frac{1}{4}$	5	10 to 12 incl.

<sup>a</sup>Morse. For amount of taper see Table 1b on page 908.

All dimensions are given in inches. Material is high-speed steel. The chamfer on the cutting end of the reamer is optional. Squared shank reamers are standard with straight flutes. Tapered shank reamers are standard with straight or spiral flutes. Spiral flute reamers are standard with left-hand spiral flutes.

**Tolerances:** On overall length A and flute length B, in taper numbers 0 to 3, incl.,  $\pm\frac{1}{16}$  inch, in taper numbers 4 and 5,  $\pm\frac{3}{32}$  inch. On length of square C, in taper numbers 0 to 3, incl.,  $\pm\frac{1}{32}$  inch; in taper numbers 4 and 5,  $\pm\frac{1}{16}$  inch. On shank diameter D, - .0005 to - .002 inch. On size of square, in taper numbers 0 and 1, - .004 inch; in taper numbers 2 and 3, - .006 inch; in taper numbers 4 and 5, - .008 inch.

Taper Pipe Reamers—Spiral Flutes ANSI B94.2-1983, R1988

Nom. Size	Diameter		Length Overall A	Flute Length B	Square Length C	Shank Diameter D	Size of Square	No. of Flutes
	Large End	Small End						
1/8	0.362	0.316	2 1/4	3/4	3/8	0.4375	0.328	4 to 6
1/4	0.472	0.406	2 7/16	1 1/8	7/16	0.5625	0.421	4 to 6
3/8	0.606	0.540	2 9/16	1 3/8	1/2	0.7000	0.531	4 to 6
1/2	0.751	0.665	3 1/8	1 3/4	5/8	0.6875	0.515	4 to 6
3/4	0.962	0.876	3 3/4	1 3/4	11/16	0.9063	0.679	6 to 10
1	1.212	1.103	3 3/4	1 3/4	1 1/16	1.1290	0.843	6 to 10
1 1/4	1.553	1.444	4	1 3/4	1 1/4	1.3125	0.984	6 to 10
1 1/2	1.793	1.684	4 1/2	1 3/4	1	1.5000	1.125	6 to 10
2	2.268	2.159	4 1/2	1 3/4	1 1/4	1.8750	1.406	8 to 12

All dimensions are given in inches. These reamers are tapered 3/8 inch per foot and are intended for reaming holes to be tapped with American National Standard Taper Pipe Thread taps. Material is high-speed steel. Reamers are standard with left-hand spiral flutes.

Tolerances: On length overall A and flute length B, 1/8 to 3/4-inch size, incl., ±1/64 inch; 1- to 1 1/2-inch size, incl., ±1/32 inch; 2-inch size, ±1/16 inch. On length of square C, 1/8 to 3/4-inch size, incl., ±1/32 inch; 1- to 2-inch size, incl., ±1/16 inch. On shank diameter D, 1/8-inch size, - .0015 inch; 1/4- to 1-inch size, incl., - .002 inch; 1 1/2- to 2-inch size, incl., - .003 inch. On size of square, 1/2-inch size, - .004 inch; 3/4- to 3/2-inch size, incl., - .006 inch; 1- to 2-inch size, incl., - .008 inch.

B & S Taper Reamers—Straight and Spiral Flutes, Squared Shank

Taper No.*	Dia. Small End	Dia. Large End	Overall Length	Square Length	Flute Length	Dia. of Shank	Size of Square	No. of Flutes
1	0.1974	0.3176	4 1/4	1/2	2 1/4	3/16	0.210	4 to 6
2	0.2474	0.3781	5 1/4	5/8	3 1/4	1/8	0.255	4 to 6
3	0.3099	0.4510	5 3/4	3/4	3 3/8	1/8	0.305	4 to 6
4	0.3474	0.5017	5 3/4	3/4	3 11/16	7/16	0.330	4 to 6
5	0.4474	0.6145	6 3/4	1/2	4	3/16	0.420	4 to 6
6	0.4974	0.6808	6 3/4	3/4	4 3/8	3/8	0.470	4 to 6
7	0.5974	0.8011	7 1/2	3/4	4 3/4	3/4	0.560	6 to 8
8	0.7474	0.9770	8 1/4	5/8	5 1/2	3/8	0.610	6 to 8
9	0.8974	1.1530	8 3/4	3/4	6 1/2	1	0.750	6 to 8
10	1.0420	1.3376	9 1/2	1	6 3/4	1 1/8	0.845	6 to 8

\*For taper per foot, see Table 10 on page 916.

These reamers are no longer ANSI Standard.

All dimensions are given in inches. Material is high-speed steel. The chamfer on the cutting end of the reamer is optional. All reamers are finishing reamers. Spiral flute reamers are standard with left-hand spiral flutes. (Tapered reamers, especially those with left-hand spirals, should not have circular lands because cutting must take place on the outer diameter of the tool.) B & S taper reamers are designed for use in reaming out Brown & Sharpe standard taper sockets.

Tolerances: On length overall A and flute length B, taper nos. 1 to 7, incl., ±1/64 inch; taper nos. 8 to 10, incl., ±1/32 inch. On length of square C, taper nos. 1 to 9, incl., ±1/32 inch; taper no. 10, ±1/16 inch. On shank diameter D, - .0005 to - .002 inch. On size of square, taper nos. 1 to 3, incl., - .004 inch; taper nos. 4 to 9, incl., - .006 inch; taper no. 10, - .008 inch.

American National Standard Die-Maker's Reamers ANSI B94.2-1983, R1988



Letter Size	Diameter		Length		Letter Size	Diameter		Length		Letter Size	Diameter		Length	
	Small End	Large End	A	B		Small End	Large End	A	B		Small End	Large End	A	B
AAA	0.055	0.070	2 1/4	1 1/2	G	0.135	0.158	3	1 1/2	O	0.250	0.296	5	3 1/2
AA	0.065	0.080	2 1/4	1 1/2	H	0.145	0.169	3 1/4	1 1/2	P	0.275	0.327	5 1/2	4
A	0.075	0.090	2 1/4	1 1/2	I	0.160	0.184	3 1/2	1 1/2	Q	0.300	0.358	6	4 1/2
B	0.085	0.103	2 1/2	1 1/2	J	0.175	0.199	3 1/2	1 1/2	R	0.335	0.397	6 1/2	4 3/4
C	0.095	0.113	2 1/2	1 1/2	K	0.190	0.219	3 1/2	2 1/4	S	0.370	0.435	6 1/2	5
D	0.105	0.126	2 1/2	1 1/2	L	0.205	0.234	3 1/2	2 1/4	T	0.405	0.473	7	5 1/2
E	0.115	0.136	2 1/4	1 1/2	M	0.220	0.252	4	2 1/2	U	0.440	0.511	7 1/2	5 1/2
F	0.125	0.148	3	1 1/2	N	0.235	0.274	4 1/2	3	...	...	...	...	...

All dimensions in inches. Material is high-speed steel. These reamers are designed for use in die-making, have a taper of 3/4 degree included angle or 0.013 inch per inch, and have 2 or 3 flutes. Reamers are standard with left-hand spiral flutes.

Tip of reamer may have conical end.

Tolerances: On length overall A and flute length B, ±1/16 inch.

Taper Pin Reamers — Straight and Left-Hand Spiral Flutes, Squared Shank; and Left-Hand High-Spiral Flutes, Round Shank ANSI B94.2-1983, R1988



No. of Taper Pin Reamer	Diameter at Large End of Reamer (Ref.)	Diameter at Small End of Reamer (Ref.)	Overall Length of Reamer A	Length of Flute B	Length of Square C	Diameter of Shank D	Size of Square <sup>a</sup>
8/0 <sup>b</sup>	0.0514	0.0351	1 1/4	3/8	...	1/8	...
7/0	0.0666	0.0497	1 3/4	1/2	3/8	3/8	0.060
6/0	0.0806	0.0611	1 3/4	1/2	3/8	3/8	0.070
5/0	0.0966	0.0719	2 1/8	1 1/8	3/8	3/8	0.080
4/0	0.1142	0.0869	2 1/8	1 1/8	3/8	3/8	0.095
3/0	0.1302	0.1029	2 3/8	1 3/8	3/8	3/8	0.105
2/0	0.1462	0.1137	2 3/8	1 3/8	3/8	3/8	0.115
0	0.1638	0.1287	2 3/8	1 3/8	3/8	3/8	0.130
1	0.1798	0.1447	2 3/8	1 3/8	3/8	3/8	0.140
2	0.2008	0.1605	3 1/8	1 3/8	3/8	3/8	0.150
3	0.2254	0.1813	3 1/8	2 1/8	3/8	3/8	0.175
4	0.2604	0.2071	4 1/8	2 3/8	3/8	3/8	0.200
5	0.2994	0.2409	4 1/8	2 3/8	3/8	3/8	0.235
6	0.3540	0.2773	5 1/8	3 1/8	3/8	3/8	0.270
7	0.4220	0.3297	6 1/8	4 1/8	3/8	3/8	0.305
8	0.5050	0.3971	7 1/8	5 1/8	3/8	3/8	0.330
9	0.6066	0.4805	8 1/8	6 1/8	3/8	3/8	0.420
10	0.7216	0.5799	9 1/8	6 3/8	3/8	3/8	0.470

<sup>a</sup>Not applicable to high-spiral flute reamers.

<sup>b</sup>Not applicable to straight and left-hand spiral fluted, squared shank reamers.

All dimensions in inches. Reamers have a taper of 1/4 inch per foot and are made of high-speed steel. Straight flute reamers of carbon steel are also standard. The number of flutes is as follows; 3 or 4, for 7/0 to 4/0 sizes; 4 to 6, for 3/0 to 0 sizes; 5 or 6, for 1 to 5 sizes; 6 to 8, for 6 to 9 sizes; 7 or 8, for the 10 size in the case of straight- and spiral-flute reamers; and 2 or 3, for 8/0 to 8 sizes; 2 to 4, for the 9 and 10 sizes in the case of high-spiral flute reamers.

Tolerances: On length overall A and flute length B, ±1/16 inch. On length of square C, ±1/32 inch. On shank diameter D, -.001 to -.005 inch for straight- and spiral-flute reamers and -.0005 to -.002 inch for high-spiral flute reamers. On size of square, -.004 inch for 7/0 to 7 sizes and -.006 inch for 8 to 10 sizes.

### TWIST DRILLS AND COUNTERBORES

Twist drills are rotary end-cutting tools having one or more cutting lips and one or more straight or helical flutes for the passage of chips and cutting fluids. Twist drills are made with straight or tapered shanks, but most have straight shanks. All but the smaller sizes are ground with "back taper," reducing the diameter from the point toward the shank, to prevent binding in the hole when the drill is worn.

*Straight Shank Drills:* Straight shank drills have cylindrical shanks which may be of the same or of a different diameter than the body diameter of the drill and may be made with or without driving flats, tang, or grooves.

*Taper Shank Drills:* Taper shank drills are preferable to the straight shank type for drilling medium and large size holes. The taper on the shank conforms to one of the tapers in the American Standard (Morse) Series.

**American National Standard.**—American National Standard B94.11M-1993 covers nomenclature, definitions, sizes and tolerances for High Speed Steel Straight and Taper Shank Drills and Combined Drills and Countersinks, Plain and Bell types. It covers both inch and metric sizes. Dimensional tables from the Standard will be found on the following pages.

**Definitions of Twist Drill Terms.**—The following definitions are included in the Standard.

*Axis:* The imaginary straight line which forms the longitudinal center of the drill.

*Back Taper:* A slight decrease in diameter from point to back in the body of the drill.

*Body:* The portion of the drill extending from the shank or neck to the outer corners of the cutting lips.

*Body Diameter Clearance:* That portion of the land that has been cut away so it will not rub against the wall of the hole.

*Chisel Edge:* The edge at the ends of the web that connects the cutting lips.

*Chisel Edge Angle:* The angle included between the chisel edge and the cutting lip as viewed from the end of the drill.

*Clearance Diameter:* The diameter over the cutaway portion of the drill lands.

*Drill Diameter:* The diameter over the margins of the drill measured at the point.

*Flutes:* Helical or straight grooves cut or formed in the body of the drill to provide cutting lips, to permit removal of chips, and to allow cutting fluid to reach the cutting lips.

*Helix Angle:* The angle made by the leading edge of the land with a plane containing the axis of the drill.

*Land:* The peripheral portion of the drill body between adjacent flutes.

*Land Width:* The distance between the leading edge and the heel of the land measured at a right angle to the leading edge.

*Lips—Two Flute Drill:* The cutting edges extending from the chisel edge to the periphery.

*Lips—Three or Four Flute Drill (Core Drill):* The cutting edges extending from the bottom of the chamfer to the periphery.

*Lip Relief:* The axial relief on the drill point.

*Lip Relief Angle:* The axial relief angle at the outer corner of the lip. It is measured by projection into a plane tangent to the periphery at the outer corner of the lip. (Lip relief angle is usually measured across the margin of the twist drill.)

*Margin:* The cylindrical portion of the land which is not cut away to provide clearance.

*Neck:* The section of reduced diameter between the body and the shank of a drill.

*Overall Length:* The length from the extreme end of the shank to the outer corners of the cutting lips. It does not include the conical shank end often used on straight shank drills, nor does it include the conical cutting point used on both straight and taper shank drills. (For core drills with an external center on the cutting end it is the same as for two-flute

drills. For core drills with an internal center on the cutting end, the overall length is to the extreme ends of the tool.)

**Point:** The cutting end of a drill made up of the ends of the lands, the web, and the lips. In form, it resembles a cone, but departs from a true cone to furnish clearance behind the cutting lips.

**Point Angle:** The angle included between the lips projected upon a plane parallel to the drill axis and parallel to the cutting lips.

**Shank:** The part of the drill by which it is held and driven.

**Tang:** The flattened end of a taper shank, intended to fit into a driving slot in the socket.

**Tang Drive:** Two opposite parallel driving flats on the end of a straight shank.

**Web:** The central portion of the body that joins the end of the lands. The end of the web forms the chisel edge on a two-flute drill.

**Web Thickness:** The thickness of the web at the point unless another specific location is indicated.

**Web Thinning:** The operation of reducing the web thickness at the point to reduce drilling thrust.

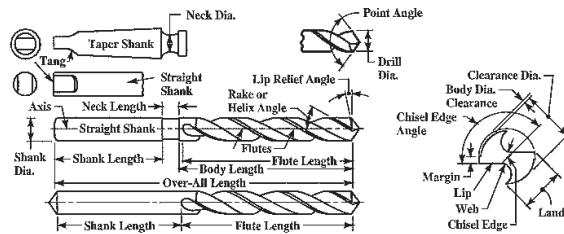

ANSI Standard Twist Drill Nomenclature

**Types of Drill.**—Drills may be classified based on the type of shank, number of flutes or hand of cut.

**Straight Shank Drills:** Those having cylindrical shanks which may be the same or different diameter than the body of the drill. The shank may be with or without driving flats, tang, grooves, or threads.

**Taper Shank Drills:** Those having conical shanks suitable for direct fitting into tapered holes in machine spindles, driving sleeves, or sockets. Tapered shanks generally have a driving tang.

**Two-Flute Drills:** The conventional type of drill used for originating holes.

**Three-Flute Drills (Core Drills):** Drill commonly used for enlarging and finishing drilled, cast or punched holes. They will not produce original holes.

**Four-Flute Drills (Core Drills):** Used interchangeably with three-flute drills. They are of similar construction except for the number of flutes.

**Right-Hand Cut:** When viewed from the cutting point, the counterclockwise rotation of a drill in order to cut.

**Left-Hand Cut:** When viewed from the cutting point, the clockwise rotation of a drill in order to cut.

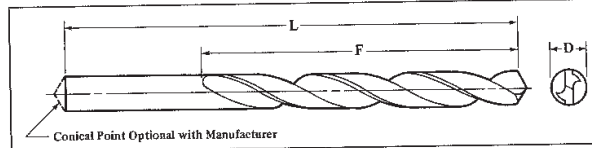

**Table 7. ANSI Straight Shank Twist Drills — Jobbers Length through 17.5 mm, Taper Length through 12.7 mm, and Screw Machine Length through 25.4 mm Diameter ANS/ASME B94.11M-1993**

Fraction No. or Lit.	Drill Diameter, D*		Jobbers Length				Taper Length				Screw Machine Length			
	Equivalent		Flute		Overall		Flute		Overall		Flute		Overall	
	mm	Decimal In.	mm	In.	mm	In.	mm	In.	mm	In.	mm	In.	mm	In.
97	0.15	0.0059	0.150	5/16	1.6	5/16	19	...	...	...	...	...	...	...
96	0.16	0.0063	0.160	5/16	1.6	5/16	19	...	...	...	...	...	...	...
95	0.17	0.0067	0.170	5/16	1.6	5/16	19	...	...	...	...	...	...	...
94	0.18	0.0071	0.180	5/16	1.6	5/16	19	...	...	...	...	...	...	...
93	0.19	0.0075	0.190	5/16	1.6	5/16	19	...	...	...	...	...	...	...
92	0.20	0.0079	0.200	5/16	1.6	5/16	19	...	...	...	...	...	...	...
91		0.0083	0.211	5/16	2.0	5/16	19	...	...	...	...	...	...	...
90	0.22	0.0087	0.221	5/16	2.0	5/16	19	...	...	...	...	...	...	...
89		0.0091	0.231	5/16	2.0	5/16	19	...	...	...	...	...	...	...
88		0.0095	0.241	5/16	2.0	5/16	19	...	...	...	...	...	...	...
	0.25	0.0098	0.250	5/16	2.0	5/16	19	...	...	...	...	...	...	...
87		0.0100	0.254	5/16	2.0	5/16	19	...	...	...	...	...	...	...
86		0.0105	0.267	5/16	2.4	5/16	19	...	...	...	...	...	...	...
85	0.28	0.0110	0.280	5/16	2.4	5/16	19	...	...	...	...	...	...	...
84		0.0115	0.292	5/16	2.4	5/16	19	...	...	...	...	...	...	...
	0.30	0.0118	0.300	5/16	2.4	5/16	19	...	...	...	...	...	...	...
83		0.0120	0.305	5/16	2.4	5/16	19	...	...	...	...	...	...	...
82		0.0125	0.318	5/16	2.4	5/16	19	...	...	...	...	...	...	...
	0.32	0.0126	0.320	5/16	2.4	5/16	19	...	...	...	...	...	...	...
81		0.0130	0.330	5/16	2.4	5/16	19	...	...	...	...	...	...	...
80		0.0135	0.343	5/16	3	5/16	19	...	...	...	...	...	...	...
	0.35	0.0138	0.350	5/16	3	5/16	19	...	...	...	...	...	...	...
79		0.0145	0.368	5/16	3	5/16	19	...	...	...	...	...	...	...
	0.38	0.0150	0.380	5/16	5	5/16	19	...	...	...	...	...	...	...
78		0.0155	0.396	5/16	5	5/16	19	...	...	...	...	...	...	...
	0.40	0.0157	0.400	5/16	5	5/16	19	...	...	...	...	...	...	...
		0.0160	0.406	5/16	5	5/16	22	...	...	...	...	...	...	...
	0.42	0.0165	0.420	5/16	5	5/16	22	...	...	...	...	...	...	...
	0.45	0.0177	0.450	5/16	5	5/16	22	...	...	...	...	...	...	...
77		0.0180	0.457	5/16	5	5/16	22	...	...	...	...	...	...	...
	0.48	0.0189	0.480	5/16	5	5/16	22	...	...	...	...	...	...	...
	0.50	0.0197	0.500	5/16	5	5/16	22	...	...	...	...	...	...	...
76		0.0200	0.508	5/16	5	5/16	22	...	...	...	...	...	...	...
75		0.0210	0.533	5/16	6	1	25	...	...	...	...	...	...	...
	0.55	0.0217	0.550	5/16	6	1	25	...	...	...	...	...	...	...
74		0.0225	0.572	5/16	6	1	25	...	...	...	...	...	...	...
	0.60	0.0236	0.600	5/16	8	1 1/8	29	...	...	...	...	...	...	...



**Table 7. (Continued) ANSI Straight Shank Twist Drills — Jobbers Length through 17.5 mm, Taper Length through 12.7 mm, and Screw Machine Length through 25.4 mm Diameter ANSI/ASME B94.11M-1993**

Fraction No. or Ltr.	Drill Diameter, D <sup>a</sup>			Jobbers Length				Taper Length				Screw Machine Length			
	mm	Equivalent		Flute		Overall		Flute		Overall		Flute		Overall	
		Decimal In.	mm	In.	mm	In.	mm	In.	mm	In.	mm	In.	mm	In.	mm
73	0.0240	0.610	5/64	8	1 1/4	29	...	...	...	...	...	...	...	...	
72	0.0250	0.635	5/64	8	1 1/4	29	...	...	...	...	...	...	...	...	
71	0.0256	0.650	5/64	10	1 1/4	32	...	...	...	...	...	...	...	...	
70	0.0260	0.660	5/64	10	1 1/4	32	...	...	...	...	...	...	...	...	
69	0.0276	0.700	5/64	10	1 1/4	32	...	...	...	...	...	...	...	...	
68	0.0280	0.711	5/64	10	1 1/4	32	...	...	...	...	...	...	...	...	
67	0.0292	0.742	1/2	13	1 1/4	35	...	...	...	...	...	...	...	...	
66	0.0295	0.750	1/2	13	1 1/4	35	...	...	...	...	...	...	...	...	
65	0.0310	0.787	1/2	13	1 1/4	35	...	...	...	...	...	...	...	...	
64	0.0312	0.792	1/2	13	1 1/4	35	...	...	...	...	...	...	...	...	
63	0.0315	0.800	1/2	13	1 1/4	35	...	...	...	...	...	...	...	...	
62	0.0320	0.813	1/2	13	1 1/4	35	...	...	...	...	...	...	...	...	
61	0.0330	0.838	1/2	13	1 1/4	35	...	...	...	...	...	...	...	...	
60	0.0335	0.850	5/16	16	1 1/2	38	...	...	...	...	...	...	...	...	
59	0.0350	0.889	5/16	16	1 1/2	38	...	...	...	...	...	...	...	...	
58	0.0354	0.899	5/16	16	1 1/2	38	...	...	...	...	...	...	...	...	
57	0.0360	0.914	5/16	16	1 1/2	38	...	...	...	...	...	...	...	...	
56	0.0370	0.940	5/16	16	1 1/2	38	...	...	...	...	...	...	...	...	
55	0.0374	0.950	5/16	16	1 1/2	38	...	...	...	...	...	...	...	...	
54	0.0380	0.965	5/16	16	1 1/2	38	...	...	...	...	...	...	...	...	
53	0.0390	0.991	3/8	17	1 3/8	41	...	...	...	...	...	...	...	...	
52	0.0394	1.000	3/8	17	1 3/8	41	1 1/8	29	2 1/4	57	1/2	13	1 1/8	35	
51	0.0400	1.016	3/8	17	1 3/8	41	1 1/8	29	2 1/4	57	1/2	13	1 1/8	35	
50	0.0410	1.041	3/8	17	1 3/8	41	1 1/8	29	2 1/4	57	1/2	13	1 1/8	35	
49	0.0413	1.050	3/8	17	1 3/8	41	1 1/8	29	2 1/4	57	1/2	13	1 1/8	35	
48	0.0420	1.067	3/8	17	1 3/8	41	1 1/8	29	2 1/4	57	1/2	13	1 1/8	35	
47	0.0430	1.092	3/8	19	1 3/8	44	1 1/8	29	2 1/4	57	1/2	13	1 1/8	35	
46	0.0433	1.100	3/8	19	1 3/8	44	1 1/8	29	2 1/4	57	1/2	13	1 1/8	35	
45	0.0453	1.150	3/8	19	1 3/8	44	1 1/8	29	2 1/4	57	1/2	13	1 1/8	35	
44	0.0465	1.181	3/8	19	1 3/8	44	1 1/8	29	2 1/4	57	1/2	13	1 1/8	35	
43	0.0469	1.191	3/8	19	1 3/8	44	1 1/8	29	2 1/4	57	1/2	13	1 1/8	35	
42	0.0472	1.200	3/8	22	1 3/8	48	1 1/8	44	3	76	3/8	16	1 1/8	41	
41	0.0492	1.250	3/8	22	1 3/8	48	1 1/8	44	3	76	3/8	16	1 1/8	41	
40	0.0512	1.300	3/8	22	1 3/8	48	1 1/8	44	3	76	3/8	16	1 1/8	41	
39	0.0520	1.321	3/8	22	1 3/8	48	1 1/8	44	3	76	3/8	16	1 1/8	41	
38	0.0531	1.350	3/8	22	1 3/8	48	1 1/8	44	3	76	3/8	16	1 1/8	41	
37	0.0550	1.397	3/8	22	1 3/8	48	1 1/8	44	3	76	3/8	16	1 1/8	41	
36	0.0551	1.400	3/8	22	1 3/8	48	1 1/8	44	3	76	3/8	16	1 1/8	41	
35	0.0571	1.450	3/8	22	1 3/8	48	1 1/8	44	3	76	3/8	16	1 1/8	41	
34	0.0591	1.500	3/8	22	1 3/8	48	1 1/8	44	3	76	3/8	16	1 1/8	41	
33	0.0595	1.511	3/8	22	1 3/8	48	1 1/8	44	3	76	3/8	16	1 1/8	41	
32	0.0610	1.550	3/8	22	1 3/8	48	1 1/8	44	3	76	3/8	16	1 1/8	41	
31	0.0625	1.588	3/8	22	1 3/8	48	1 1/8	44	3	76	3/8	16	1 1/8	41	
30	0.0630	1.600	3/8	22	1 3/8	48	2	51	3 1/2	95	1/2	17	1 1/8	43	
29	0.0635	1.613	3/8	22	1 3/8	48	2	51	3 1/2	95	1/2	17	1 1/8	43	
28	0.0650	1.650	1	25	2	51	2	51	3 1/2	95	1/2	17	1 1/8	43	

Table 7. (Continued) ANSI Straight Shank Twist Drills — Jobbers Length through 17.5 mm, Taper Length through 12.7 mm, and Screw Machine Length through 25.4 mm Diameter ANSIA SME B94.1 M-1993

Fraction No. or Ltr.	Drill Diameter, D <sup>a</sup>			Jobbers Length				Taper Length				Screw Machine Length			
	mm	Equivalent		Flute		Overall		Flute		Overall		Flute		Overall	
		Decimal In.	mm	In.	mm	In.	mm	In.	mm	In.	mm	In.	mm	In.	mm
51	1.70	0.0669	1.700	1	25	2	51	2	51	3 3/4	95	1 1/8	17	1 1/8	43
		0.0670	1.702	1	25	2	51	2	51	3 3/4	95	1 1/8	17	1 1/8	43
50	1.75	0.0689	1.750	1	25	2	51	2	51	3 3/4	95	1 1/8	17	1 1/8	43
		0.0700	1.778	1	25	2	51	2	51	3 3/4	95	1 1/8	17	1 1/8	43
49	1.80	0.0709	1.800	1	25	2	51	2	51	3 3/4	95	1 1/8	17	1 1/8	43
		0.0728	1.850	1	25	2	51	2	51	3 3/4	95	1 1/8	17	1 1/8	43
48	1.85	0.0730	1.854	1	25	2	51	2	51	3 3/4	95	1 1/8	17	1 1/8	43
		0.0748	1.900	1	25	2	51	2	51	3 3/4	95	1 1/8	17	1 1/8	43
3/4	1.90	0.0760	1.930	1	25	2	51	2	51	3 3/4	95	1 1/8	17	1 1/8	43
		0.0768	1.950	1	25	2	51	2	51	3 3/4	95	1 1/8	17	1 1/8	43
47	1.95	0.0781	1.984	1	25	2	51	2	51	3 3/4	95	1 1/8	17	1 1/8	43
		0.0785	1.994	1	25	2	51	2 1/4	57	4 1/2	108	1 3/8	17	1 3/8	43
46	2.00	0.0787	2.000	1	25	2	51	2 1/4	57	4 1/2	108	1 3/8	17	1 3/8	43
		0.0807	2.050	1 1/8	29	2 1/2	54	2 1/4	57	4 1/2	108	1 3/8	19	1 3/8	44
45	2.05	0.0810	2.057	1 1/8	29	2 1/2	54	2 1/4	57	4 1/2	108	1 3/8	19	1 3/8	44
		0.0820	2.083	1 1/8	29	2 1/2	54	2 1/4	57	4 1/2	108	1 3/8	19	1 3/8	44
44	2.10	0.0827	2.100	1 1/8	29	2 1/2	54	2 1/4	57	4 1/2	108	1 3/8	19	1 3/8	44
		0.0846	2.150	1 1/8	29	2 1/2	54	2 1/4	57	4 1/2	108	1 3/8	19	1 3/8	44
43	2.15	0.0860	2.184	1 1/8	29	2 1/2	54	2 1/4	57	4 1/2	108	1 3/8	19	1 3/8	44
		0.0866	2.200	1 1/8	32	2 1/2	57	2 1/4	57	4 1/2	108	1 3/8	19	1 3/8	44
42	2.20	0.0886	2.250	1 1/4	32	2 1/2	57	2 1/4	57	4 1/2	108	1 3/8	19	1 3/8	44
		0.0890	2.261	1 1/4	32	2 1/2	57	2 1/4	57	4 1/2	108	1 3/8	19	1 3/8	44
41	2.25	0.0906	2.300	1 1/4	32	2 1/2	57	2 1/4	57	4 1/2	108	1 3/8	19	1 3/8	44
		0.0925	2.350	1 1/4	32	2 1/2	57	2 1/4	57	4 1/2	108	1 3/8	19	1 3/8	44
40	2.30	0.0935	2.375	1 1/4	32	2 1/2	57	2 1/4	57	4 1/2	108	1 3/8	19	1 3/8	44
		0.0938	2.383	1 1/4	32	2 1/2	57	2 1/4	57	4 1/2	108	1 3/8	19	1 3/8	44
39	2.35	0.0945	2.400	1 1/4	35	2 3/8	60	2 1/2	64	4 3/4	117	1 3/8	21	1 3/8	46
		0.0960	2.438	1 1/4	35	2 3/8	60	2 1/2	64	4 3/4	117	1 3/8	21	1 3/8	46
38	2.40	0.0965	2.450	1 1/4	35	2 3/8	60	2 1/2	64	4 3/4	117	1 3/8	21	1 3/8	46
		0.0980	2.489	1 1/4	35	2 3/8	60	2 1/2	64	4 3/4	117	1 3/8	21	1 3/8	46
37	2.46	0.0984	2.500	1 1/4	35	2 3/8	60	2 1/2	64	4 3/4	117	1 3/8	21	1 3/8	46
		0.0995	2.527	1 1/4	35	2 3/8	60	2 1/2	64	4 3/4	117	1 3/8	21	1 3/8	46
36	2.50	0.1015	2.578	1 1/4	37	2 1/2	64	2 1/2	64	4 3/4	117	1 3/8	21	1 3/8	46
		0.1024	2.600	1 1/4	37	2 1/2	64	2 1/2	64	4 3/4	117	1 3/8	21	1 3/8	46
35	2.60	0.1040	2.642	1 1/4	37	2 1/2	64	2 1/2	64	4 3/4	117	1 3/8	21	1 3/8	46
		0.1063	2.700	1 1/4	37	2 1/2	64	2 1/2	64	4 3/4	117	1 3/8	21	1 3/8	46
34	2.70	0.1065	2.705	1 1/4	37	2 1/2	64	2 1/2	64	4 3/4	117	1 3/8	21	1 3/8	46
		0.1094	2.779	1 1/4	38	2 3/8	67	2 1/2	70	5 1/4	130	1 3/8	22	1 3/8	48
33	2.80	0.1100	2.794	1 1/4	38	2 3/8	67	2 1/2	70	5 1/4	130	1 3/8	22	1 3/8	48
		0.1102	2.800	1 1/4	38	2 3/8	67	2 1/2	70	5 1/4	130	1 3/8	22	1 3/8	48
32	2.90	0.1110	2.819	1 1/4	38	2 3/8	67	2 1/2	70	5 1/4	130	1 3/8	22	1 3/8	48
		0.1130	2.870	1 1/4	38	2 3/8	67	2 1/2	70	5 1/4	130	1 3/8	22	1 3/8	48
31	3.00	0.1142	2.900	1 1/4	41	2 1/2	70	2 1/2	70	5 1/4	130	1 3/8	22	1 3/8	48
		0.1160	2.946	1 1/4	41	2 1/2	70	2 1/2	70	5 1/4	130	1 3/8	22	1 3/8	48
		0.1181	3.000	1 1/4	41	2 1/2	70	2 1/2	70	5 1/4	130	1 3/8	22	1 3/8	48
		0.1200	3.048	1 1/4	41	2 1/2	70	2 1/2	70	5 1/4	130	1 3/8	22	1 3/8	48

**Table 7. (Continued) ANSI Straight Shank Twist Drills — Jobbers Length through 17.5 mm, Taper Length through 12.7 mm, and Screw Machine Length through 25.4 mm Diameter ANSI/ASME B94.11M-1993**

Fraction No. or Ltr.	Drill Diameter, D <sup>a</sup>		Jobbers Length				Taper Length				Screw Machine Length				
	mm	Equivalent	Flute		Overall		Flute		Overall		Flute		Overall		
			F	L	F	L	F	L	F	L					
1/8	3.10	0.1220	3.100	1 3/8	41	2 1/4	70	2 1/4	70	5/8	130	7/8	22	1 1/4	48
		0.1250	3.175	1 3/8	41	2 1/4	70	2 1/4	70	5/8	130	7/8	22	1 1/4	48
3/16	3.20	0.1260	3.200	1 3/8	41	2 1/4	70	3	76	5/8	137	7/8	24	1 1/2	49
		0.1285	3.264	1 3/8	41	2 1/4	70	3	76	5/8	137	7/8	24	1 1/2	49
1/4	3.30	0.1299	3.300	1 3/8	44	2 3/8	73	3	76	5/8	137	7/8	24	1 1/2	49
		0.1339	3.400	1 3/8	44	2 3/8	73	3	76	5/8	137	7/8	24	1 1/2	49
5/16	3.40	0.1360	3.454	1 3/8	44	2 3/8	73	3	76	5/8	137	7/8	24	1 1/2	49
		0.1378	3.500	1 3/8	44	2 3/8	73	3	76	5/8	137	7/8	24	1 1/2	49
3/8	3.50	0.1405	3.569	1 3/8	44	2 3/8	73	3	76	5/8	137	7/8	24	1 1/2	49
		0.1406	3.571	1 3/8	44	2 3/8	73	3	76	5/8	137	7/8	24	1 1/2	49
7/16	3.60	0.1417	3.600	1 3/8	48	3	76	3	76	5/8	137	1	25	2 1/8	52
		0.1440	3.658	1 3/8	48	3	76	3	76	5/8	137	1	25	2 1/8	52
1/2	3.70	0.1457	3.700	1 3/8	48	3	76	3	76	5/8	137	1	25	2 1/8	52
		0.1470	3.734	1 3/8	48	3	76	3	76	5/8	137	1	25	2 1/8	52
9/16	3.80	0.1495	3.797	1 3/8	48	3	76	3	76	5/8	137	1	25	2 1/8	52
		0.1496	3.800	1 3/8	48	3	76	3	76	5/8	137	1	25	2 1/8	52
5/8	3.90	0.1520	3.861	2	51	3 1/2	79	3	76	5/8	137	1	25	2 1/8	52
		0.1535	3.900	2	51	3 1/2	79	3	76	5/8	137	1	25	2 1/8	52
3/4	4.00	0.1540	3.912	2	51	3 1/2	79	3	76	5/8	137	1	25	2 1/8	52
		0.1562	3.967	2	51	3 1/2	79	3	76	5/8	137	1	25	2 1/8	52
7/8	4.10	0.1570	3.988	2	51	3 1/2	79	3 3/4	86	5/8	146	1 1/8	27	2 1/4	54
		0.1575	4.000	2 1/2	54	3 1/2	83	3 3/4	86	5/8	146	1 1/8	27	2 1/4	54
1 1/16	4.20	0.1590	4.039	2 1/2	54	3 1/2	83	3 3/4	86	5/8	146	1 1/8	27	2 1/4	54
		0.1610	4.089	2 1/2	54	3 1/2	83	3 3/4	86	5/8	146	1 1/8	27	2 1/4	54
1 1/8	4.30	0.1614	4.100	2 1/2	54	3 1/2	83	3 3/4	86	5/8	146	1 1/8	27	2 1/4	54
		0.1654	4.200	2 1/2	54	3 1/2	83	3 3/4	86	5/8	146	1 1/8	27	2 1/4	54
1 1/4	4.40	0.1660	4.216	2 1/2	54	3 1/2	83	3 3/4	86	5/8	146	1 1/8	27	2 1/4	54
		0.1693	4.300	2 1/2	54	3 1/2	83	3 3/4	86	5/8	146	1 1/8	27	2 1/4	54
1 3/16	4.50	0.1695	4.305	2 1/2	54	3 1/2	83	3 3/4	86	5/8	146	1 1/8	27	2 1/4	54
		0.1719	4.366	2 1/2	54	3 1/2	83	3 3/4	86	5/8	146	1 1/8	27	2 1/4	54
1 1/2	4.60	0.1730	4.394	2 1/2	56	3 3/4	86	3 3/4	86	5/8	146	1 1/4	29	2 1/2	56
		0.1732	4.400	2 1/2	56	3 3/4	86	3 3/4	86	5/8	146	1 1/4	29	2 1/2	56
1 3/8	4.70	0.1770	4.496	2 3/8	56	3 3/4	86	3 3/4	86	5/8	146	1 1/4	29	2 1/2	56
		0.1772	4.500	2 3/8	56	3 3/4	86	3 3/4	86	5/8	146	1 1/4	29	2 1/2	56
1 5/16	4.80	0.1800	4.572	2 3/8	56	3 3/4	86	3 3/4	86	5/8	146	1 1/4	29	2 1/2	56
		0.1811	4.600	2 3/8	56	3 3/4	86	3 3/4	86	5/8	146	1 1/4	29	2 1/2	56
1 7/16	4.90	0.1820	4.623	2 3/8	56	3 3/4	86	3 3/4	86	5/8	146	1 1/4	29	2 1/2	56
		0.1850	4.700	2 3/8	59	3 3/4	89	3 3/4	86	5/8	146	1 1/4	29	2 1/2	56
1 1/2	5.00	0.1875	4.762	2 3/8	59	3 3/4	89	3 3/4	86	5/8	146	1 1/4	29	2 1/2	56
		0.1890	4.800	2 3/8	59	3 3/4	89	3 3/4	92	6	152	1 3/8	30	2 1/2	57
1 3/4	5.10	0.1910	4.851	2 3/8	59	3 3/4	89	3 3/4	92	6	152	1 3/8	30	2 1/2	57
		0.1929	4.900	2 3/8	62	3 3/4	92	3 3/4	92	6	152	1 3/8	30	2 1/2	57
1 5/8	5.20	0.1935	4.915	2 3/8	62	3 3/4	92	3 3/4	92	6	152	1 3/8	30	2 1/2	57
		0.1960	4.978	2 3/8	62	3 3/4	92	3 3/4	92	6	152	1 3/8	30	2 1/2	57
1 7/8	5.30	0.1969	5.000	2 3/8	62	3 3/4	92	3 3/4	92	6	152	1 3/8	30	2 1/2	57
		0.1990	5.054	2 3/8	62	3 3/4	92	3 3/4	92	6	152	1 3/8	30	2 1/2	57

**Table 7. (Continued) ANSI Straight Shank Twist Drills — Jobbers Length through 17.5 mm, Taper Length through 12.7 mm, and Screw Machine Length through 25.4 mm Diameter ANSASME B94.11M-1993**

Fraction No. or Ltr.	Drill Diameter, D <sup>a</sup>		Jobbers Length				Taper Length				Screw Machine Length				
	mm	Equivalent	Flute		Overall L	Flute		Overall L	Flute		Overall L				
			F	L		F	L		F	L					
	Decimal In.	mm	In.	mm	In.	mm	In.	mm	In.	mm	In.	mm			
7	5.10	0.2008	5.100	2 <sup>1</sup> / <sub>16</sub>	62	3 <sup>3</sup> / <sub>8</sub>	92	3 <sup>3</sup> / <sub>8</sub>	92	6	152	1 <sup>3</sup> / <sub>8</sub>	30	2 <sup>1</sup> / <sub>2</sub>	57
		0.2010	5.105	2 <sup>1</sup> / <sub>16</sub>	62	3 <sup>3</sup> / <sub>8</sub>	92	3 <sup>3</sup> / <sub>8</sub>	92	6	152	1 <sup>3</sup> / <sub>8</sub>	30	2 <sup>1</sup> / <sub>2</sub>	57
		0.2031	5.159	2 <sup>1</sup> / <sub>16</sub>	62	3 <sup>3</sup> / <sub>8</sub>	92	3 <sup>3</sup> / <sub>8</sub>	92	6	152	1 <sup>3</sup> / <sub>8</sub>	30	2 <sup>1</sup> / <sub>2</sub>	57
5/8	6	0.2040	5.182	2 <sup>1</sup> / <sub>16</sub>	64	3 <sup>3</sup> / <sub>8</sub>	95	3 <sup>3</sup> / <sub>8</sub>	92	6	152	1 <sup>3</sup> / <sub>8</sub>	32	2 <sup>1</sup> / <sub>2</sub>	60
		0.2047	5.200	2 <sup>1</sup> / <sub>16</sub>	64	3 <sup>3</sup> / <sub>8</sub>	95	3 <sup>3</sup> / <sub>8</sub>	92	6	152	1 <sup>3</sup> / <sub>8</sub>	32	2 <sup>1</sup> / <sub>2</sub>	60
5	5.20	0.2055	5.220	2 <sup>1</sup> / <sub>16</sub>	64	3 <sup>3</sup> / <sub>8</sub>	95	3 <sup>3</sup> / <sub>8</sub>	92	6	152	1 <sup>3</sup> / <sub>8</sub>	32	2 <sup>1</sup> / <sub>2</sub>	60
		0.2087	5.300	2 <sup>1</sup> / <sub>16</sub>	64	3 <sup>3</sup> / <sub>8</sub>	95	3 <sup>3</sup> / <sub>8</sub>	92	6	152	1 <sup>3</sup> / <sub>8</sub>	32	2 <sup>1</sup> / <sub>2</sub>	60
4	5.30	0.2090	5.308	2 <sup>1</sup> / <sub>16</sub>	64	3 <sup>3</sup> / <sub>8</sub>	95	3 <sup>3</sup> / <sub>8</sub>	92	6	152	1 <sup>3</sup> / <sub>8</sub>	32	2 <sup>1</sup> / <sub>2</sub>	60
		0.2126	5.400	2 <sup>1</sup> / <sub>16</sub>	64	3 <sup>3</sup> / <sub>8</sub>	95	3 <sup>3</sup> / <sub>8</sub>	92	6	152	1 <sup>3</sup> / <sub>8</sub>	32	2 <sup>1</sup> / <sub>2</sub>	60
3	5.40	0.2130	5.410	2 <sup>1</sup> / <sub>16</sub>	64	3 <sup>3</sup> / <sub>8</sub>	95	3 <sup>3</sup> / <sub>8</sub>	92	6	152	1 <sup>3</sup> / <sub>8</sub>	32	2 <sup>1</sup> / <sub>2</sub>	60
		0.2165	5.500	2 <sup>1</sup> / <sub>16</sub>	64	3 <sup>3</sup> / <sub>8</sub>	95	3 <sup>3</sup> / <sub>8</sub>	92	6	152	1 <sup>3</sup> / <sub>8</sub>	32	2 <sup>1</sup> / <sub>2</sub>	60
3/8	5.50	0.2188	5.558	2 <sup>1</sup> / <sub>16</sub>	64	3 <sup>3</sup> / <sub>8</sub>	95	3 <sup>3</sup> / <sub>8</sub>	92	6	152	1 <sup>3</sup> / <sub>8</sub>	32	2 <sup>1</sup> / <sub>2</sub>	60
		0.2205	5.600	2 <sup>1</sup> / <sub>16</sub>	67	3 <sup>3</sup> / <sub>8</sub>	98	3 <sup>3</sup> / <sub>8</sub>	95	6 <sup>1</sup> / <sub>4</sub>	156	1 <sup>3</sup> / <sub>8</sub>	33	2 <sup>1</sup> / <sub>2</sub>	62
2	5.60	0.2210	5.613	2 <sup>1</sup> / <sub>16</sub>	67	3 <sup>3</sup> / <sub>8</sub>	98	3 <sup>3</sup> / <sub>8</sub>	95	6 <sup>1</sup> / <sub>4</sub>	156	1 <sup>3</sup> / <sub>8</sub>	33	2 <sup>1</sup> / <sub>2</sub>	62
		0.2244	5.700	2 <sup>1</sup> / <sub>16</sub>	67	3 <sup>3</sup> / <sub>8</sub>	98	3 <sup>3</sup> / <sub>8</sub>	95	6 <sup>1</sup> / <sub>4</sub>	156	1 <sup>3</sup> / <sub>8</sub>	33	2 <sup>1</sup> / <sub>2</sub>	62
1	5.80	0.2280	5.791	2 <sup>1</sup> / <sub>16</sub>	67	3 <sup>3</sup> / <sub>8</sub>	98	3 <sup>3</sup> / <sub>8</sub>	95	6 <sup>1</sup> / <sub>4</sub>	156	1 <sup>3</sup> / <sub>8</sub>	33	2 <sup>1</sup> / <sub>2</sub>	62
		0.2283	5.800	2 <sup>1</sup> / <sub>16</sub>	67	3 <sup>3</sup> / <sub>8</sub>	98	3 <sup>3</sup> / <sub>8</sub>	95	6 <sup>1</sup> / <sub>4</sub>	156	1 <sup>3</sup> / <sub>8</sub>	33	2 <sup>1</sup> / <sub>2</sub>	62
A	5.90	0.2323	5.900	2 <sup>1</sup> / <sub>16</sub>	67	3 <sup>3</sup> / <sub>8</sub>	98	3 <sup>3</sup> / <sub>8</sub>	95	6 <sup>1</sup> / <sub>4</sub>	156	1 <sup>3</sup> / <sub>8</sub>	33	2 <sup>1</sup> / <sub>2</sub>	62
		0.2340	5.944	2 <sup>1</sup> / <sub>16</sub>	67	3 <sup>3</sup> / <sub>8</sub>	98	...	...	...	...	1 <sup>3</sup> / <sub>8</sub>	33	2 <sup>1</sup> / <sub>2</sub>	62
1/4	6.00	0.2344	5.954	2 <sup>1</sup> / <sub>16</sub>	67	3 <sup>3</sup> / <sub>8</sub>	98	3 <sup>3</sup> / <sub>8</sub>	95	6 <sup>1</sup> / <sub>4</sub>	156	1 <sup>3</sup> / <sub>8</sub>	33	2 <sup>1</sup> / <sub>2</sub>	62
		0.2362	6.000	2 <sup>1</sup> / <sub>16</sub>	70	4	102	3 <sup>3</sup> / <sub>8</sub>	95	6 <sup>1</sup> / <sub>4</sub>	156	1 <sup>3</sup> / <sub>8</sub>	35	2 <sup>1</sup> / <sub>2</sub>	64
B	6.10	0.2380	6.045	2 <sup>1</sup> / <sub>16</sub>	70	4	102	...	...	...	...	1 <sup>3</sup> / <sub>8</sub>	35	2 <sup>1</sup> / <sub>2</sub>	64
		0.2402	6.100	2 <sup>1</sup> / <sub>16</sub>	70	4	102	3 <sup>3</sup> / <sub>8</sub>	95	6 <sup>1</sup> / <sub>4</sub>	156	1 <sup>3</sup> / <sub>8</sub>	35	2 <sup>1</sup> / <sub>2</sub>	64
C	6.20	0.2420	6.147	2 <sup>1</sup> / <sub>16</sub>	70	4	102	...	...	...	...	1 <sup>3</sup> / <sub>8</sub>	35	2 <sup>1</sup> / <sub>2</sub>	64
		0.2441	6.200	2 <sup>1</sup> / <sub>16</sub>	70	4	102	3 <sup>3</sup> / <sub>8</sub>	95	6 <sup>1</sup> / <sub>4</sub>	156	1 <sup>3</sup> / <sub>8</sub>	35	2 <sup>1</sup> / <sub>2</sub>	64
D	6.30	0.2460	6.248	2 <sup>1</sup> / <sub>16</sub>	70	4	102	...	...	...	...	1 <sup>3</sup> / <sub>8</sub>	35	2 <sup>1</sup> / <sub>2</sub>	64
		0.2480	6.300	2 <sup>1</sup> / <sub>16</sub>	70	4	102	3 <sup>3</sup> / <sub>8</sub>	95	6 <sup>1</sup> / <sub>4</sub>	156	1 <sup>3</sup> / <sub>8</sub>	35	2 <sup>1</sup> / <sub>2</sub>	64
E, 1/4	6.40	0.2500	6.350	2 <sup>1</sup> / <sub>16</sub>	70	4	102	3 <sup>3</sup> / <sub>8</sub>	95	6 <sup>1</sup> / <sub>4</sub>	156	1 <sup>3</sup> / <sub>8</sub>	35	2 <sup>1</sup> / <sub>2</sub>	64
		0.2520	6.400	2 <sup>1</sup> / <sub>16</sub>	73	4 <sup>1</sup> / <sub>2</sub>	105	3 <sup>3</sup> / <sub>8</sub>	98	6 <sup>1</sup> / <sub>4</sub>	159	1 <sup>3</sup> / <sub>8</sub>	37	2 <sup>1</sup> / <sub>2</sub>	67
F	6.50	0.2559	6.500	2 <sup>1</sup> / <sub>16</sub>	73	4 <sup>1</sup> / <sub>2</sub>	105	3 <sup>3</sup> / <sub>8</sub>	98	6 <sup>1</sup> / <sub>4</sub>	159	1 <sup>3</sup> / <sub>8</sub>	37	2 <sup>1</sup> / <sub>2</sub>	67
		0.2570	6.528	2 <sup>1</sup> / <sub>16</sub>	73	4 <sup>1</sup> / <sub>2</sub>	105	...	...	...	...	1 <sup>3</sup> / <sub>8</sub>	37	2 <sup>1</sup> / <sub>2</sub>	67
G	6.60	0.2598	6.600	2 <sup>1</sup> / <sub>16</sub>	73	4 <sup>1</sup> / <sub>2</sub>	105	...	...	...	...	1 <sup>3</sup> / <sub>8</sub>	37	2 <sup>1</sup> / <sub>2</sub>	67
		0.2610	6.629	2 <sup>1</sup> / <sub>16</sub>	73	4 <sup>1</sup> / <sub>2</sub>	105	...	...	...	...	1 <sup>3</sup> / <sub>8</sub>	37	2 <sup>1</sup> / <sub>2</sub>	67
3/8	6.70	0.2638	6.700	2 <sup>1</sup> / <sub>16</sub>	73	4 <sup>1</sup> / <sub>2</sub>	105	...	...	...	...	1 <sup>3</sup> / <sub>8</sub>	37	2 <sup>1</sup> / <sub>2</sub>	67
		0.2656	6.746	2 <sup>1</sup> / <sub>16</sub>	73	4 <sup>1</sup> / <sub>2</sub>	105	3 <sup>3</sup> / <sub>8</sub>	98	6 <sup>1</sup> / <sub>4</sub>	159	1 <sup>3</sup> / <sub>8</sub>	37	2 <sup>1</sup> / <sub>2</sub>	67
H	6.80	0.2660	6.756	2 <sup>1</sup> / <sub>16</sub>	73	4 <sup>1</sup> / <sub>2</sub>	105	...	...	...	...	1 <sup>3</sup> / <sub>8</sub>	38	2 <sup>1</sup> / <sub>2</sub>	68
		0.2677	6.800	2 <sup>1</sup> / <sub>16</sub>	73	4 <sup>1</sup> / <sub>2</sub>	105	3 <sup>3</sup> / <sub>8</sub>	98	6 <sup>1</sup> / <sub>4</sub>	159	1 <sup>3</sup> / <sub>8</sub>	38	2 <sup>1</sup> / <sub>2</sub>	68
I	6.90	0.2717	6.900	2 <sup>1</sup> / <sub>16</sub>	73	4 <sup>1</sup> / <sub>2</sub>	105	...	...	...	...	1 <sup>3</sup> / <sub>8</sub>	38	2 <sup>1</sup> / <sub>2</sub>	68
		0.2720	6.909	2 <sup>1</sup> / <sub>16</sub>	73	4 <sup>1</sup> / <sub>2</sub>	105	...	...	...	...	1 <sup>3</sup> / <sub>8</sub>	38	2 <sup>1</sup> / <sub>2</sub>	68
J	7.00	0.2756	7.000	2 <sup>1</sup> / <sub>16</sub>	73	4 <sup>1</sup> / <sub>2</sub>	105	3 <sup>3</sup> / <sub>8</sub>	98	6 <sup>1</sup> / <sub>4</sub>	159	1 <sup>3</sup> / <sub>8</sub>	38	2 <sup>1</sup> / <sub>2</sub>	68
		0.2770	7.036	2 <sup>1</sup> / <sub>16</sub>	73	4 <sup>1</sup> / <sub>2</sub>	105	...	...	...	...	1 <sup>3</sup> / <sub>8</sub>	38	2 <sup>1</sup> / <sub>2</sub>	68
K	7.10	0.2795	7.100	2 <sup>1</sup> / <sub>16</sub>	75	4 <sup>1</sup> / <sub>2</sub>	108	...	...	...	...	1 <sup>3</sup> / <sub>8</sub>	38	2 <sup>1</sup> / <sub>2</sub>	68
		0.2810	7.137	2 <sup>1</sup> / <sub>16</sub>	75	4 <sup>1</sup> / <sub>2</sub>	108	...	...	...	...	1 <sup>3</sup> / <sub>8</sub>	38	2 <sup>1</sup> / <sub>2</sub>	68
3/4	7.20	0.2812	7.142	2 <sup>1</sup> / <sub>16</sub>	75	4 <sup>1</sup> / <sub>2</sub>	108	3 <sup>3</sup> / <sub>8</sub>	98	6 <sup>1</sup> / <sub>4</sub>	159	1 <sup>3</sup> / <sub>8</sub>	40	2 <sup>1</sup> / <sub>2</sub>	70
		0.2835	7.200	2 <sup>1</sup> / <sub>16</sub>	75	4 <sup>1</sup> / <sub>2</sub>	108	4	102	6 <sup>1</sup> / <sub>4</sub>	162	1 <sup>3</sup> / <sub>8</sub>	40	2 <sup>1</sup> / <sub>2</sub>	70
2	7.30	0.2874	7.300	2 <sup>1</sup> / <sub>16</sub>	75	4 <sup>1</sup> / <sub>2</sub>	108	...	...	...	...	1 <sup>3</sup> / <sub>8</sub>	40	2 <sup>1</sup> / <sub>2</sub>	70

**Table 7. (Continued) ANSI Straight Shank Twist Drills — Jobbers Length through 17.5 mm, Taper Length through 12.7 mm, and Screw Machine Length through 25.4 mm Diameter ANSI/ASME B94.11M-1993**

Fraction No. or L <sub>F</sub>	Drill Diameter, D <sup>2</sup>		Jobbers Length				Taper Length				Screw Machine Length			
	Equivalent		Flute		Overall		Flute		Overall		Flute		Overall	
	mm	Decimal In.	mm	In.	mm	In.	mm	In.	mm	In.	mm	In.	mm	In.
L	7.40	0.2900	7.366	2 <sup>3</sup> / <sub>16</sub>	75	4 <sup>1</sup> / <sub>2</sub>	108	...	...	...	1 <sup>3</sup> / <sub>16</sub>	40	2 <sup>1</sup> / <sub>2</sub>	70
		0.2913	7.400	3 <sup>1</sup> / <sub>16</sub>	78	4 <sup>1</sup> / <sub>2</sub>	111	...	...	...	1 <sup>3</sup> / <sub>16</sub>	40	2 <sup>1</sup> / <sub>2</sub>	70
M	7.50	0.2930	7.493	3 <sup>1</sup> / <sub>16</sub>	78	4 <sup>1</sup> / <sub>2</sub>	111	...	...	...	1 <sup>3</sup> / <sub>16</sub>	40	2 <sup>1</sup> / <sub>2</sub>	70
		0.2933	7.500	3 <sup>1</sup> / <sub>16</sub>	78	4 <sup>1</sup> / <sub>2</sub>	111	4	102	6 <sup>3</sup> / <sub>8</sub>	162	1 <sup>3</sup> / <sub>16</sub>	40	2 <sup>1</sup> / <sub>2</sub>
3/8	7.60	0.2969	7.541	3 <sup>1</sup> / <sub>16</sub>	78	4 <sup>1</sup> / <sub>2</sub>	111	4	102	6 <sup>3</sup> / <sub>8</sub>	162	1 <sup>3</sup> / <sub>16</sub>	40	2 <sup>1</sup> / <sub>2</sub>
		0.2992	7.600	3 <sup>1</sup> / <sub>16</sub>	78	4 <sup>1</sup> / <sub>2</sub>	111	...	...	...	1 <sup>3</sup> / <sub>16</sub>	41	2 <sup>1</sup> / <sub>2</sub>	71
N	7.70	0.3020	7.671	3 <sup>1</sup> / <sub>16</sub>	78	4 <sup>1</sup> / <sub>2</sub>	111	...	...	...	1 <sup>3</sup> / <sub>16</sub>	41	2 <sup>1</sup> / <sub>2</sub>	71
		0.3031	7.700	3 <sup>1</sup> / <sub>16</sub>	81	4 <sup>1</sup> / <sub>2</sub>	114	...	...	...	1 <sup>3</sup> / <sub>16</sub>	41	2 <sup>1</sup> / <sub>2</sub>	71
5/16	7.80	0.3071	7.800	3 <sup>1</sup> / <sub>16</sub>	81	4 <sup>1</sup> / <sub>2</sub>	114	4	102	6 <sup>3</sup> / <sub>8</sub>	162	1 <sup>3</sup> / <sub>16</sub>	41	2 <sup>1</sup> / <sub>2</sub>
		0.3110	7.900	3 <sup>1</sup> / <sub>16</sub>	81	4 <sup>1</sup> / <sub>2</sub>	114	...	...	...	1 <sup>3</sup> / <sub>16</sub>	41	2 <sup>1</sup> / <sub>2</sub>	71
3/8	8.00	0.3125	7.938	3 <sup>1</sup> / <sub>16</sub>	81	4 <sup>1</sup> / <sub>2</sub>	114	4	102	6 <sup>3</sup> / <sub>8</sub>	162	1 <sup>3</sup> / <sub>16</sub>	41	2 <sup>1</sup> / <sub>2</sub>
		0.3150	8.000	3 <sup>1</sup> / <sub>16</sub>	81	4 <sup>1</sup> / <sub>2</sub>	114	4 <sup>1</sup> / <sub>2</sub>	105	6 <sup>1</sup> / <sub>2</sub>	165	1 <sup>3</sup> / <sub>16</sub>	43	2 <sup>1</sup> / <sub>2</sub>
O	8.10	0.3160	8.026	3 <sup>1</sup> / <sub>16</sub>	81	4 <sup>1</sup> / <sub>2</sub>	114	...	...	...	1 <sup>3</sup> / <sub>16</sub>	43	2 <sup>1</sup> / <sub>2</sub>	75
		0.3189	8.100	3 <sup>1</sup> / <sub>16</sub>	84	4 <sup>1</sup> / <sub>2</sub>	117	...	...	...	1 <sup>3</sup> / <sub>16</sub>	43	2 <sup>1</sup> / <sub>2</sub>	75
P	8.20	0.3228	8.200	3 <sup>1</sup> / <sub>16</sub>	84	4 <sup>1</sup> / <sub>2</sub>	117	4 <sup>1</sup> / <sub>2</sub>	105	6 <sup>1</sup> / <sub>2</sub>	165	1 <sup>3</sup> / <sub>16</sub>	43	2 <sup>1</sup> / <sub>2</sub>
		0.3230	8.204	3 <sup>1</sup> / <sub>16</sub>	84	4 <sup>1</sup> / <sub>2</sub>	117	...	...	...	1 <sup>3</sup> / <sub>16</sub>	43	2 <sup>1</sup> / <sub>2</sub>	75
3/8	8.30	0.3268	8.300	3 <sup>1</sup> / <sub>16</sub>	84	4 <sup>1</sup> / <sub>2</sub>	117	...	...	...	1 <sup>3</sup> / <sub>16</sub>	43	2 <sup>1</sup> / <sub>2</sub>	75
		0.3281	8.334	3 <sup>1</sup> / <sub>16</sub>	84	4 <sup>1</sup> / <sub>2</sub>	117	4 <sup>1</sup> / <sub>2</sub>	105	6 <sup>1</sup> / <sub>2</sub>	165	1 <sup>3</sup> / <sub>16</sub>	43	2 <sup>1</sup> / <sub>2</sub>
Q	8.40	0.3307	8.400	3 <sup>1</sup> / <sub>16</sub>	87	4 <sup>1</sup> / <sub>2</sub>	121	...	...	...	1 <sup>3</sup> / <sub>16</sub>	43	3	76
		0.3320	8.433	3 <sup>1</sup> / <sub>16</sub>	87	4 <sup>1</sup> / <sub>2</sub>	121	...	...	...	1 <sup>3</sup> / <sub>16</sub>	43	3	76
R	8.50	0.3346	8.500	3 <sup>1</sup> / <sub>16</sub>	87	4 <sup>1</sup> / <sub>2</sub>	121	4 <sup>1</sup> / <sub>2</sub>	106	6 <sup>1</sup> / <sub>2</sub>	165	1 <sup>3</sup> / <sub>16</sub>	43	3
		0.3386	8.600	3 <sup>1</sup> / <sub>16</sub>	87	4 <sup>1</sup> / <sub>2</sub>	121	...	...	...	1 <sup>3</sup> / <sub>16</sub>	43	3	76
1/2	8.70	0.3390	8.611	3 <sup>1</sup> / <sub>16</sub>	87	4 <sup>1</sup> / <sub>2</sub>	121	...	...	...	1 <sup>3</sup> / <sub>16</sub>	43	3	76
		0.3425	8.700	3 <sup>1</sup> / <sub>16</sub>	87	4 <sup>1</sup> / <sub>2</sub>	121	...	...	...	1 <sup>3</sup> / <sub>16</sub>	43	3	76
S	8.80	0.3438	8.733	3 <sup>1</sup> / <sub>16</sub>	87	4 <sup>1</sup> / <sub>2</sub>	121	4 <sup>1</sup> / <sub>2</sub>	105	6 <sup>1</sup> / <sub>2</sub>	165	1 <sup>3</sup> / <sub>16</sub>	43	3
		0.3465	8.800	3 <sup>1</sup> / <sub>16</sub>	89	4 <sup>1</sup> / <sub>2</sub>	124	4 <sup>1</sup> / <sub>2</sub>	108	6 <sup>1</sup> / <sub>2</sub>	171	1 <sup>3</sup> / <sub>16</sub>	44	3 <sup>1</sup> / <sub>8</sub>
T	9.00	0.3480	8.839	3 <sup>1</sup> / <sub>16</sub>	89	4 <sup>1</sup> / <sub>2</sub>	124	...	...	...	1 <sup>3</sup> / <sub>16</sub>	44	3 <sup>1</sup> / <sub>8</sub>	78
		0.3504	8.900	3 <sup>1</sup> / <sub>16</sub>	89	4 <sup>1</sup> / <sub>2</sub>	124	...	...	...	1 <sup>3</sup> / <sub>16</sub>	44	3 <sup>1</sup> / <sub>8</sub>	78
3/4	9.10	0.3543	9.090	3 <sup>1</sup> / <sub>16</sub>	89	4 <sup>1</sup> / <sub>2</sub>	124	4 <sup>1</sup> / <sub>2</sub>	108	6 <sup>1</sup> / <sub>2</sub>	171	1 <sup>3</sup> / <sub>16</sub>	44	3 <sup>1</sup> / <sub>8</sub>
		0.3580	9.093	3 <sup>1</sup> / <sub>16</sub>	89	4 <sup>1</sup> / <sub>2</sub>	124	...	...	...	1 <sup>3</sup> / <sub>16</sub>	44	3 <sup>1</sup> / <sub>8</sub>	78
U	9.20	0.3583	9.100	3 <sup>1</sup> / <sub>16</sub>	89	4 <sup>1</sup> / <sub>2</sub>	124	...	...	...	1 <sup>3</sup> / <sub>16</sub>	44	3 <sup>1</sup> / <sub>8</sub>	78
		0.3594	9.129	3 <sup>1</sup> / <sub>16</sub>	89	4 <sup>1</sup> / <sub>2</sub>	124	4 <sup>1</sup> / <sub>2</sub>	108	6 <sup>1</sup> / <sub>2</sub>	171	1 <sup>3</sup> / <sub>16</sub>	44	3 <sup>1</sup> / <sub>8</sub>
5/8	9.30	0.3622	9.200	3 <sup>1</sup> / <sub>16</sub>	92	5	127	4 <sup>1</sup> / <sub>2</sub>	108	6 <sup>1</sup> / <sub>2</sub>	171	1 <sup>3</sup> / <sub>16</sub>	46	3 <sup>1</sup> / <sub>8</sub>
		0.3661	9.300	3 <sup>1</sup> / <sub>16</sub>	92	5	127	...	...	...	1 <sup>3</sup> / <sub>16</sub>	46	3 <sup>1</sup> / <sub>8</sub>	79
V	9.40	0.3680	9.347	3 <sup>1</sup> / <sub>16</sub>	92	5	127	...	...	...	1 <sup>3</sup> / <sub>16</sub>	46	3 <sup>1</sup> / <sub>8</sub>	79
		0.3701	9.400	3 <sup>1</sup> / <sub>16</sub>	92	5	127	...	...	...	1 <sup>3</sup> / <sub>16</sub>	46	3 <sup>1</sup> / <sub>8</sub>	79
3/4	9.50	0.3740	9.500	3 <sup>1</sup> / <sub>16</sub>	92	5	127	4 <sup>1</sup> / <sub>2</sub>	108	6 <sup>1</sup> / <sub>2</sub>	171	1 <sup>3</sup> / <sub>16</sub>	46	3 <sup>1</sup> / <sub>8</sub>
		0.3750	9.525	3 <sup>1</sup> / <sub>16</sub>	92	5	127	4 <sup>1</sup> / <sub>2</sub>	108	6 <sup>1</sup> / <sub>2</sub>	171	1 <sup>3</sup> / <sub>16</sub>	46	3 <sup>1</sup> / <sub>8</sub>
W	9.70	0.3770	9.576	3 <sup>1</sup> / <sub>16</sub>	92	5	127	...	...	...	1 <sup>3</sup> / <sub>16</sub>	48	3 <sup>1</sup> / <sub>8</sub>	83
		0.3780	9.600	3 <sup>1</sup> / <sub>16</sub>	95	5 <sup>1</sup> / <sub>2</sub>	130	...	...	...	1 <sup>3</sup> / <sub>16</sub>	48	3 <sup>1</sup> / <sub>8</sub>	83
3/4	9.80	0.3819	9.700	3 <sup>1</sup> / <sub>16</sub>	95	5 <sup>1</sup> / <sub>2</sub>	130	...	...	...	1 <sup>3</sup> / <sub>16</sub>	48	3 <sup>1</sup> / <sub>8</sub>	83
		0.3858	9.800	3 <sup>1</sup> / <sub>16</sub>	95	5 <sup>1</sup> / <sub>2</sub>	130	4 <sup>1</sup> / <sub>2</sub>	111	7	178	1 <sup>3</sup> / <sub>16</sub>	48	3 <sup>1</sup> / <sub>8</sub>
5/8	9.90	0.3860	9.804	3 <sup>1</sup> / <sub>16</sub>	95	5 <sup>1</sup> / <sub>2</sub>	130	...	...	...	1 <sup>3</sup> / <sub>16</sub>	48	3 <sup>1</sup> / <sub>8</sub>	83
		0.3898	9.900	3 <sup>1</sup> / <sub>16</sub>	95	5 <sup>1</sup> / <sub>2</sub>	130	...	...	...	1 <sup>3</sup> / <sub>16</sub>	48	3 <sup>1</sup> / <sub>8</sub>	83
3/4	10.00	0.3906	9.921	3 <sup>1</sup> / <sub>16</sub>	95	5 <sup>1</sup> / <sub>2</sub>	130	4 <sup>1</sup> / <sub>2</sub>	111	7	178	1 <sup>3</sup> / <sub>16</sub>	48	3 <sup>1</sup> / <sub>8</sub>
		0.3937	10.000	3 <sup>1</sup> / <sub>16</sub>	95	5 <sup>1</sup> / <sub>2</sub>	130	4 <sup>1</sup> / <sub>2</sub>	111	7	178	1 <sup>3</sup> / <sub>16</sub>	49	3 <sup>1</sup> / <sub>8</sub>

Table 7. (Continued) ANSI Straight Shank Twist Drills — Jobbers Length through 17.5 mm, Taper Length through 12.7 mm, and Screw Machine Length through 25.4 mm Diameter ANS/ASME B94.11M-1993

Fraction No. or Ltr.	Drill Diameter, D <sup>a</sup>		Jobbers Length				Taper Length				Screw Machine Length				
	Equivalent		Flute		Overall		Flute		Overall		Flute		Overall		
	mm	Decimal In.	mm	In.	mm	In.	mm	In.	mm	In.	mm	In.	mm	In.	
X	10.20	0.3970	10.084	3 3/8	95	4 1/4	130	...	...	...	1 1/2	49	3 1/2	84	
		0.4016	10.200	3 7/8	98	5 1/4	133	4 3/8	111	7	178	1 1/2	49	3 1/2	84
Y	10.50	0.4040	10.262	3 7/8	98	5 1/4	133	...	...	...	1 1/2	49	3 1/2	84	
		0.4062	10.317	3 7/8	98	5 1/4	133	4 3/8	111	7	178	1 1/2	49	3 1/2	84
Z	10.50	0.4130	10.490	3 7/8	98	5 1/4	133	...	...	...	2	51	3 1/2	86	
		0.4134	10.500	3 7/8	98	5 1/4	133	4 3/8	117	7 1/2	184	2	51	3 1/2	86
3/64	10.80	0.4219	10.716	3 15/16	100	5 1/4	137	4 3/8	117	7 1/2	184	2	51	3 1/2	86
		0.4252	10.800	4 1/16	103	5 1/2	140	4 3/8	117	7 1/2	184	2 1/2	52	3 1/2	87
1/8	11.00	0.4331	11.000	4 1/16	103	5 1/2	140	4 3/8	117	7 1/2	184	2 1/2	52	3 1/2	87
		0.4375	11.112	4 1/8	103	5 1/2	140	4 3/8	117	7 1/2	184	2 1/2	52	3 1/2	87
3/16	11.20	0.4409	11.200	4 1/8	106	5 3/8	143	4 3/8	121	7 1/2	190	2 1/2	54	3 1/2	90
		0.4528	11.500	4 3/8	106	5 3/8	143	4 3/8	121	7 1/2	190	2 1/2	54	3 1/2	90
1/4	11.50	0.4531	11.509	4 3/8	106	5 3/8	143	4 3/8	121	7 1/2	190	2 1/2	54	3 1/2	90
		0.4646	11.800	4 3/4	110	5 3/4	146	4 3/8	121	7 1/2	190	2 1/2	54	3 1/2	92
5/32	11.80	0.4688	11.908	4 3/4	110	5 3/4	146	4 3/8	121	7 1/2	190	2 1/2	54	3 1/2	92
		0.4724	12.000	4 3/4	111	5 3/4	149	4 3/8	121	7 1/2	197	2 1/2	56	3 1/2	94
3/8	12.00	0.4803	12.200	4 7/8	111	5 3/4	149	4 3/8	121	7 1/2	197	2 1/2	56	3 1/2	94
		0.4844	12.304	4 7/8	111	5 3/4	149	4 3/8	121	7 1/2	197	2 1/2	56	3 1/2	94
7/16	12.50	0.4921	12.500	4 7/8	114	6	152	4 3/8	121	7 1/2	197	2 1/2	57	3 1/2	95
		0.5000	12.700	4 7/8	114	6	152	4 3/8	121	7 1/2	197	2 1/2	57	3 1/2	95
1/2	12.80	0.5039	12.800	4 7/8	114	6	152	...	...	...	2 1/2	60	3 1/2	98	
		0.5118	13.000	4 7/8	114	6	152	...	...	...	2 1/2	60	3 1/2	98	
5/8	13.00	0.5156	13.096	4 7/8	122	6 1/8	168	...	...	...	2 3/8	60	3 1/2	98	
		0.5197	13.200	4 7/8	122	6 1/8	168	...	...	...	2 3/8	60	3 1/2	98	
3/4	13.20	0.5312	13.492	4 3/4	122	6 1/8	168	...	...	...	2 3/8	60	3 1/2	98	
		0.5315	13.500	4 3/4	122	6 1/8	168	...	...	...	2 3/8	60	3 1/2	98	
7/8	13.80	0.5433	13.800	4 3/4	122	6 1/8	168	...	...	...	2 3/8	64	4	102	
		0.5499	13.891	4 3/4	122	6 1/8	168	...	...	...	2 1/2	64	4	102	
1 1/8	14.00	0.5512	14.000	4 3/4	122	6 1/8	168	...	...	...	2 1/2	64	4	102	
		0.5610	14.250	4 3/4	122	6 1/8	168	...	...	...	2 1/2	64	4	102	
1 1/4	14.25	0.5625	14.288	4 3/4	122	6 1/8	168	...	...	...	2 1/2	64	4	102	
		0.5709	14.500	4 3/4	122	6 1/8	168	...	...	...	2 3/8	67	4 1/2	105	
1 1/2	14.50	0.5781	14.684	4 3/4	122	6 1/8	168	...	...	...	2 3/8	67	4 1/2	105	
		0.5807	14.750	5 1/16	132	7 1/8	181	...	...	...	2 3/8	67	4 1/2	105	
1 3/4	15.00	0.5906	15.000	5 1/16	132	7 1/8	181	...	...	...	2 3/8	67	4 1/2	105	
		0.5938	15.083	5 1/16	132	7 1/8	181	...	...	...	2 3/8	67	4 1/2	105	
1 7/8	15.25	0.6004	15.250	5 1/8	132	7 1/8	181	...	...	...	2 3/8	70	4 1/2	108	
		0.6094	15.479	5 1/8	132	7 1/8	181	...	...	...	2 3/8	70	4 1/2	108	
2	15.50	0.6102	15.500	5 1/8	132	7 1/8	181	...	...	...	2 3/8	70	4 1/2	108	
		0.6201	15.750	5 1/8	132	7 1/8	181	...	...	...	2 3/8	70	4 1/2	108	
2 1/4	15.75	0.6250	15.875	5 1/8	132	7 1/8	181	...	...	...	2 3/8	70	4 1/2	108	
		0.6299	16.000	5 1/8	132	7 1/8	181	...	...	...	2 3/8	73	4 1/2	114	
2 1/2	16.00	0.6398	16.250	5 1/8	132	7 1/8	181	...	...	...	2 3/8	73	4 1/2	114	
		0.6406	16.271	5 1/8	132	7 1/8	181	...	...	...	2 3/8	73	4 1/2	114	
2 3/4	16.25	0.6496	16.500	5 3/8	132	7 1/8	181	...	...	...	2 3/8	73	4 1/2	114	
		0.6562	16.669	5 3/8	132	7 1/8	181	...	...	...	2 3/8	73	4 1/2	114	

**Table 7. (Continued) ANSI Straight Shank Twist Drills — Jobbers Length through 17.5 mm, Taper Length through 12.7 mm, and Screw Machine Length through 25.4 mm Diameter ANS/ASME B94.11M-1993**

Fraction No. or Ltr.	Drill Diameter, D <sup>a</sup>			Jobbers Length				Taper Length				Screw Machine Length			
	mm	Equivalent		Flute		Overall		Flute		Overall		Flute		Overall	
		Decimal In.	mm	In.	mm	In.	mm	In.	mm	In.	mm	In.	mm	In.	mm
5/64	16.75	0.6594	16.750	5/16	143	7/16	194	...	...	...	...	2 3/4	73	4 1/2	114
	17.00	0.6693	17.000	5/16	143	7/16	194	...	...	...	...	2 3/4	73	4 1/2	114
		0.6719	17.065	5/16	143	7/16	194	...	...	...	...	2 3/4	73	4 1/2	114
1/8	17.25	0.6791	17.250	5/16	143	7/16	194	...	...	...	...	2 3/4	73	4 1/2	114
		0.6875	17.462	5/16	143	7/16	194	...	...	...	...	3	76	4 1/2	121
3/16	17.50	0.6890	17.500	5/16	143	7/16	194	...	...	...	...	3	76	4 1/2	121
		0.7031	17.859	...	...	...	...	...	...	...	...	3	76	4 1/2	121
1/4	18.00	0.7087	18.000	...	...	...	...	...	...	...	...	3	76	4 1/2	121
		0.7188	18.258	...	...	...	...	...	...	...	...	3	76	4 1/2	121
5/16	18.50	0.7283	18.500	...	...	...	...	...	...	...	...	3 1/4	79	5	127
		0.7344	18.654	...	...	...	...	...	...	...	...	3 1/4	79	5	127
3/8	19.00	0.7480	19.000	...	...	...	...	...	...	...	...	3 1/2	79	5	127
		0.7500	19.050	...	...	...	...	...	...	...	...	3 1/2	79	5	127
7/16	19.50	0.7677	19.500	...	...	...	...	...	...	...	...	3 1/2	83	5 1/2	130
		0.7812	19.845	...	...	...	...	...	...	...	...	3 1/2	83	5 1/2	130
1/2	20.00	0.7879	20.000	...	...	...	...	...	...	...	...	3 3/4	86	5 1/2	133
		0.7969	20.241	...	...	...	...	...	...	...	...	3 3/4	86	5 1/2	133
5/8	20.50	0.8071	20.500	...	...	...	...	...	...	...	...	3 3/4	86	5 1/2	133
		0.8125	20.638	...	...	...	...	...	...	...	...	3 3/4	86	5 1/2	133
3/4	21.00	0.8268	21.000	...	...	...	...	...	...	...	...	3 1/2	89	5 3/4	137
		0.8281	21.034	...	...	...	...	...	...	...	...	3 1/2	89	5 3/4	137
7/8	21.50	0.8438	21.433	...	...	...	...	...	...	...	...	3 1/2	89	5 3/4	137
		0.8465	21.500	...	...	...	...	...	...	...	...	3 1/2	89	5 3/4	137
1 1/8	22.00	0.8594	21.829	...	...	...	...	...	...	...	...	3 1/2	89	5 3/4	137
		0.8661	22.000	...	...	...	...	...	...	...	...	3 1/2	89	5 3/4	137
1 1/4	22.50	0.8750	22.225	...	...	...	...	...	...	...	...	3 1/2	89	5 3/4	137
		0.8858	22.500	...	...	...	...	...	...	...	...	3 1/2	89	5 3/4	137
1 3/8	23.00	0.8906	22.621	...	...	...	...	...	...	...	...	3 3/4	92	5 3/4	143
		0.9055	23.000	...	...	...	...	...	...	...	...	3 3/4	92	5 3/4	143
1 1/2	23.50	0.9062	23.017	...	...	...	...	...	...	...	...	3 3/4	92	5 3/4	143
		0.9219	23.416	...	...	...	...	...	...	...	...	3 3/4	95	5 3/4	146
1 5/8	24.00	0.9252	23.500	...	...	...	...	...	...	...	...	3 3/4	95	5 3/4	146
		0.9375	23.812	...	...	...	...	...	...	...	...	3 3/4	95	5 3/4	146
1 3/4	24.00	0.9449	24.000	...	...	...	...	...	...	...	...	3 3/4	98	5 3/4	149
		0.9531	24.209	...	...	...	...	...	...	...	...	3 3/4	98	5 3/4	149
1 7/8	24.50	0.9646	24.500	...	...	...	...	...	...	...	...	3 3/4	98	5 3/4	149
		0.9688	24.608	...	...	...	...	...	...	...	...	4	102	6	152
2	25.00	0.9843	25.000	...	...	...	...	...	...	...	...	4	102	6	152
		0.9844	25.004	...	...	...	...	...	...	...	...	4	102	6	152
2 1/4		1.0000	25.400	...	...	...	...	...	...	...	...	4	102	6	152

<sup>a</sup>Fractional inch, number, letter, and metric sizes.

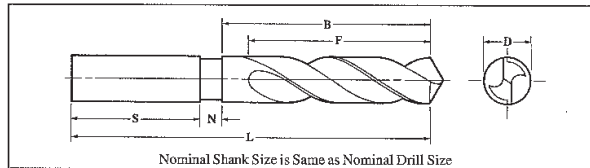

Nominal Shank Size is Same as Nominal Drill Size

**Table 8. ANSI Straight Shank Twist Drills — Taper Length — Over 1/2 in. (12.7 mm) Dia., Fractional and Metric Sizes ANSI B94.11M-1993**

Diameter of Drill			Flute Length		Overall Length		Length of Body		Minimum Length of Shk.		Maximum Length of Neck		
D			F		L		B		S		N		
Frac.	mm	Decimal Inch Equiv.	Inch	mm	Inch	mm	Inch	mm	Inch	mm	Inch	mm	
3/16	12.80	0.5039	12.800	4 1/4	121	8	203	4 7/8	124	2 3/4	66	1 1/2	13
	13.00	0.5117	13.000	4 1/4	121	8	203	4 7/8	124	2 3/4	66	1 1/2	13
	13.20	0.5197	13.096	4 1/4	121	8	203	4 7/8	124	2 3/4	66	1 1/2	13
7/32	13.50	0.5312	13.200	4 1/4	121	8	203	4 7/8	124	2 3/4	66	1 1/2	13
	13.50	0.5315	13.492	4 1/4	121	8	203	4 7/8	124	2 3/4	66	1 1/2	13
	13.80	0.5433	13.500	4 1/4	121	8	203	4 3/8	124	2 3/4	66	1 1/2	13
1/8	14.00	0.5419	13.800	4 1/4	124	8 1/2	210	5	127	2 3/4	70	1 1/2	13
	14.00	0.5512	13.891	4 1/4	124	8 1/2	210	5	127	2 3/4	70	1 1/2	13
	14.25	0.5610	14.000	4 1/4	124	8 1/2	210	5	127	2 3/4	70	1 1/2	13
3/16	14.50	0.5625	14.250	4 1/4	124	8 1/2	210	5	127	2 3/4	70	1 1/2	13
	14.50	0.5709	14.288	4 1/4	124	8 1/2	210	5	127	2 3/4	70	1 1/2	13
	14.75	0.5781	14.500	4 1/4	124	8 1/2	222	5	127	3 3/8	79	1 1/2	16
7/32	14.75	0.5807	14.684	4 1/4	124	8 1/2	222	5	127	3 3/8	79	1 1/2	16
	15.00	0.5906	14.750	4 1/4	124	8 1/2	222	5	127	3 3/8	79	1 1/2	16
	15.00	0.5938	15.000	4 1/4	124	8 1/2	222	5	127	3 3/8	79	1 1/2	16
1/4	15.25	0.6094	15.250	4 1/4	124	8 1/2	222	5	127	3 3/8	79	1 1/2	16
	15.25	0.6201	15.033	4 1/4	124	8 1/2	222	5	127	3 3/8	79	1 1/2	16
	15.50	0.6102	15.479	4 1/4	124	8 1/2	222	5	127	3 3/8	79	1 1/2	16
5/16	15.50	0.6250	15.500	4 1/4	124	8 1/2	222	5	127	3 3/8	79	1 1/2	16
	15.75	0.6201	15.750	4 1/4	124	8 1/2	222	5	127	3 3/8	79	1 1/2	16
	16.00	0.6250	15.875	4 1/4	124	8 1/2	222	5	127	3 3/8	79	1 1/2	16
3/8	16.25	0.6299	16.000	5 1/4	130	9	228	5 1/2	133	3 3/8	79	1 1/2	16
	16.25	0.6398	16.250	5 1/4	130	9	228	5 1/2	133	3 3/8	79	1 1/2	16
	16.50	0.6406	16.406	5 1/4	130	9	228	5 1/2	133	3 3/8	79	1 1/2	16
7/16	16.50	0.6496	16.500	5 1/4	130	9	228	5 1/2	133	3 3/8	79	1 1/2	16
	16.75	0.6522	16.667	5 1/4	130	9	228	5 1/2	133	3 3/8	79	1 1/2	16
	16.75	0.6594	16.750	5 3/8	137	9 1/2	235	5 1/2	140	3 3/8	79	1 1/2	16
1/2	17.00	0.6693	17.000	5 3/8	137	9 1/2	235	5 1/2	140	3 3/8	79	1 1/2	16
	17.00	0.6719	17.066	5 3/8	137	9 1/2	235	5 1/2	140	3 3/8	79	1 1/2	16
	17.25	0.6791	17.250	5 3/8	137	9 1/2	235	5 1/2	140	3 3/8	79	1 1/2	16
9/16	17.50	0.6875	17.462	5 3/8	137	9 1/2	235	5 1/2	140	3 3/8	79	1 1/2	16
	17.50	0.6890	17.859	5 3/8	143	9 1/2	241	5 1/2	146	3 3/8	79	1 1/2	16
	18.00	0.7031	17.500	5 3/8	143	9 1/2	241	5 1/2	146	3 3/8	79	1 1/2	16
5/8	18.00	0.7087	18.000	5 3/8	143	9 1/2	241	5 1/2	146	3 3/8	79	1 1/2	16
	18.00	0.7188	18.258	5 3/8	143	9 1/2	241	5 1/2	146	3 3/8	79	1 1/2	16
	18.50	0.7283	18.500	5 3/8	149	9 3/4	247	6	152	3 3/8	79	1 1/2	16
3/4	18.50	0.7344	18.654	5 3/8	149	9 3/4	247	6	152	3 3/8	79	1 1/2	16
	19.00	0.7480	19.000	5 3/8	149	9 3/4	247	6	152	3 3/8	79	1 1/2	16
	19.00	0.7500	19.050	5 3/8	149	9 3/4	247	6	152	3 3/8	79	1 1/2	16
7/8	19.00	0.7656	19.446	6	152	9 3/4	251	6 1/4	156	3 3/8	79	1 1/2	16
	19.50	0.7677	19.500	6	152	9 3/4	251	6 1/4	156	3 3/8	79	1 1/2	16
	19.50	0.7812	19.842	6	152	9 3/4	251	6 1/4	156	3 3/8	79	1 1/2	16



Table 8. (Continued) ANSI Straight Shank Twist Drills — Taper Length — Over 1/2 in. (12.7 mm) Dia., Fractional and Metric Sizes ANSI B94.11M-1993

Diameter of Drill			Flute Length		Overall Length		Length of Body		Minimum Length of Shk.		Maximum Length of Neck		
D	mm	Decimal Inch Equiv.	F	L	Z	R	S	N	Inch	mm	Inch	mm	
Frac.		Metric Equiv.	Inch	mm	Inch	mm	Inch	mm	Inch	mm	Inch	mm	
3/16	20.00	0.7874	20.000	6 1/4	156	10	254	6 1/4	159	3 1/4	79	3/4	16
		0.7969	20.241	6 1/4	156	10	254	6 1/4	159	3 1/4	79	3/4	16
	20.50	0.8071	20.500	6 1/4	156	10	254	6 1/4	159	3 1/4	79	3/4	16
1/2		0.8125	20.638	6 1/4	156	10	254	6 1/4	159	3 1/4	79	3/4	16
	21.00	0.8268	21.000	6 1/4	156	10	254	6 1/4	159	3 1/4	79	3/4	16
5/8		0.8281	21.034	6 1/4	156	10	254	6 1/4	159	3 1/4	79	3/4	16
3/4		0.8438	21.433	6 1/4	156	10	254	6 1/4	159	3 1/4	79	3/4	16
7/8		0.8465	21.500	6 1/4	156	10	254	6 1/4	159	3 1/4	79	3/4	16
1 1/8	21.50	0.8594	21.829	6 1/4	156	10	254	6 1/4	159	3 1/4	79	3/4	16
		0.8661	22.000	6 1/4	156	10	254	6 1/4	159	3 1/4	79	3/4	16
1 1/4	22.00	0.8750	22.225	6 1/4	156	10	254	6 1/4	159	3 1/4	79	3/4	16
		0.8858	22.500	6 1/4	156	10	254	6 1/4	159	3 1/4	79	3/4	16
1 1/2	22.50	0.8906	22.621	6 1/4	156	10	254	6 1/4	159	3 1/4	79	3/4	16
		0.9055	23.000	6 1/4	156	10	254	6 1/4	159	3 1/4	79	3/4	16
1 3/4	23.00	0.9062	23.017	6 1/4	156	10	254	6 1/4	159	3 1/4	79	3/4	16
		0.9219	23.416	6 1/4	156	10 1/2	273	6 1/4	159	3 1/4	79	3/4	16
2	23.50	0.9252	23.500	6 1/4	156	10 3/4	273	6 1/4	159	3 1/4	79	3/4	16
		0.9375	23.812	6 1/4	156	10 3/4	273	6 1/4	159	3 1/4	79	3/4	16
2 1/4	24.00	0.9449	24.000	6 1/4	162	11	279	6 1/4	165	3 1/4	79	3/4	16
		0.9531	24.209	6 1/4	162	11	279	6 1/4	165	3 1/4	79	3/4	16
2 1/2	24.50	0.9646	24.500	6 1/4	162	11	279	6 1/4	165	3 1/4	79	3/4	16
		0.9688	24.608	6 1/4	162	11	279	6 1/4	165	3 1/4	79	3/4	16
2 3/4	25.00	0.9843	25.000	6 1/4	162	11	279	6 1/4	165	3 1/4	79	3/4	16
		0.9844	25.004	6 1/4	162	11	279	6 1/4	165	3 1/4	79	3/4	16
3	25.00	1.0000	25.400	6 1/4	162	11	279	6 1/4	165	3 1/4	79	3/4	16
		1.0039	25.500	6 1/4	165	11 1/4	282	6 1/4	168	3 1/4	79	3/4	16
1 1/4	25.50	1.0156	25.796	6 1/4	165	11 1/4	282	6 1/4	168	3 1/4	79	3/4	16
		1.0236	26.000	6 1/4	165	11 1/4	282	6 1/4	168	3 1/4	79	3/4	16
1 1/2	26.00	1.0312	26.192	6 1/4	165	11 1/4	282	6 1/4	168	3 1/4	79	3/4	16
		1.0433	26.560	6 1/4	168	11 1/4	286	6 1/4	172	3 1/4	79	3/4	16
1 3/4	26.50	1.0469	26.591	6 1/4	168	11 1/4	286	6 1/4	172	3 1/4	79	3/4	16
		1.0625	26.988	6 1/4	168	11 1/4	286	6 1/4	172	3 1/4	79	3/4	16
2	27.00	1.0630	27.000	6 1/4	168	11 1/4	286	6 1/4	172	3 1/4	79	3/4	16
		1.0781	27.384	6 1/4	175	11 1/2	292	7	178	3 1/4	79	3/4	16
2 1/4	27.50	1.0827	27.500	6 1/4	175	11 1/2	292	7	178	3 1/4	79	3/4	16
		1.0958	27.783	6 1/4	175	11 1/2	292	7	178	3 1/4	79	3/4	16
2 1/2	28.00	1.1024	28.000	7 1/8	181	11 3/4	298	7 1/4	184	3 1/4	79	3/4	16
		1.1094	28.179	7 1/8	181	11 3/4	298	7 1/4	184	3 1/4	79	3/4	16
2 3/4	28.50	1.1220	28.500	7 1/8	181	11 3/4	298	7 1/4	184	3 1/4	79	3/4	16
		1.1250	28.575	7 1/8	181	11 3/4	298	7 1/4	184	3 1/4	79	3/4	16
3	29.00	1.1406	28.971	7 1/8	184	11 3/4	301	7 3/8	187	3 1/4	79	3/4	16
		1.1417	29.000	7 1/8	184	11 3/4	301	7 3/8	187	3 1/4	79	3/4	16
3 1/4	29.50	1.1562	29.367	7 1/8	184	11 3/4	301	7 3/8	187	3 1/4	79	3/4	16
		1.1614	29.500	7 3/8	187	12	305	7 1/2	191	3 1/4	79	3/4	16
3 1/2	30.00	1.1719	29.766	7 3/8	187	12	305	7 1/2	191	3 1/4	79	3/4	16
		1.1811	30.000	7 3/8	187	12	305	7 1/2	191	3 1/4	79	3/4	16
3 3/4	30.50	1.1875	30.162	7 3/8	187	12	305	7 1/2	191	3 1/4	79	3/4	16
		1.2008	30.500	7 3/8	190	12 1/4	308	7 5/8	194	3 1/4	79	3/4	16
4	31.00	1.2031	30.559	7 3/8	190	12 1/4	308	7 5/8	194	3 1/4	79	3/4	16
		1.2188	30.958	7 3/8	190	12 1/4	308	7 5/8	194	3 1/4	79	3/4	16
4 1/4	31.50	1.2205	31.000	7 3/8	200	12 1/2	317	8	203	3 1/4	79	3/4	16
		1.2344	31.354	7 3/8	200	12 1/2	317	8	203	3 1/4	79	3/4	16
4 1/2	31.50	1.2402	31.500	7 3/8	200	12 1/2	317	8	203	3 1/4	79	3/4	16

**Table 8. (Continued) ANSI Straight Shank Twist Drills — Taper Length — Over 1/2 in. (12.7 mm) Dia., Fractional and Metric Sizes ANSI B94.11M-1993**

Diameter of Drill			Flute Length		Overall Length		Length of Body		Minimum Length of Shk.		Maximum Length of Neck		
D	Decimal Inch Equiv.	Millimeter Equiv.	F	L	B	S	N						
Frac.	mm		Inch	mm	Inch	mm	Inch	mm	Inch	mm	Inch	mm	
1/4	32.00	1.2500	31.750	7 3/4	200	12 1/2	317	8	203	3 1/4	98	3 1/2	116
	32.09	1.2598	32.000	8 1/8	216	14 1/8	359	8 3/8	219	4 1/4	124	4 1/2	130
	32.50	1.2795	32.500	8 1/2	216	14 1/4	359	8 3/8	219	4 1/8	124	4 1/2	130
1/2		1.2812	32.542	8 1/2	216	14 1/4	359	8 3/8	219	4 1/8	124	4 1/2	130
	33.00	1.2892	33.000	8 5/8	219	14 1/2	362	8 3/8	222	4 1/4	124	4 1/2	130
			33.338	8 3/4	219	14 3/4	362	8 3/8	222	4 1/4	124	4 1/2	130
3/8	33.50	1.3125	33.500	8 3/4	222	14 3/4	365	8 3/8	225	4 1/4	124	4 1/2	130
	34.00	1.3189	34.000	8 3/4	222	14 3/4	365	8 3/8	225	4 1/4	124	4 1/2	130
			34.133	8 3/4	222	14 3/4	365	8 3/8	225	4 1/4	124	4 1/2	130
1 1/8	34.50	1.3438	34.500	8 3/4	225	14 1/2	368	9	229	4 1/4	124	4 1/2	130
			34.583	8 3/4	225	14 1/2	368	9	229	4 1/4	124	4 1/2	130
	35.00	1.3750	34.925	8 3/4	225	14 1/2	372	9 1/4	232	4 1/4	124	4 1/2	130
1 1/4	35.00	1.3780	35.000	9	229	14 3/4	372	9 1/4	232	4 1/4	124	4 1/2	130
	35.50	1.3976	35.500	9	229	14 3/4	372	9 1/4	232	4 1/4	124	4 1/2	130
			35.717	9	229	14 3/4	372	9 1/4	232	4 1/4	124	4 1/2	130
1 3/8	36.00	1.4173	36.000	9 1/8	232	14 3/4	375	9 1/4	235	4 1/4	124	4 1/2	130
	36.50	1.4370	36.500	9 1/8	232	14 3/4	375	9 1/4	235	4 1/4	124	4 1/2	130
			36.512	9 1/8	232	14 3/4	375	9 1/4	235	4 1/4	124	4 1/2	130
1 1/2	37.00	1.4567	37.000	9 1/4	235	14 3/4	378	9 1/4	238	4 1/4	124	4 1/2	130
			37.308	9 1/4	235	14 3/4	378	9 1/4	238	4 1/4	124	4 1/2	130
	37.50	1.4764	37.500	9 1/4	238	15	381	9 1/2	241	4 1/4	124	4 1/2	130
1 5/8	38.00	1.4961	38.000	9 1/2	238	15	381	9 1/2	241	4 1/4	124	4 1/2	130
			38.100	9 1/2	238	15	381	9 1/2	241	4 1/4	124	4 1/2	130
			39.688	9 1/2	244	15 1/4	387	9 1/2	247	4 1/4	124	4 1/2	130
1 7/8	1.6250	41.275	9 3/4	251	15 3/4	397	10	254	4 1/4	124	4 1/2	130	
1 3/4	1.7500	44.450	10 1/2	267	16 1/4	413	10 3/4	270	4 1/4	124	4 1/2	130	

**Table 9. American National Standard Tangs for Straight Shank Drills ANS/ASME B94.11M-1993**

Nominal Diameter of Drill Shank		Thickness of Tang				Length of Tang	
Inches	Millimeters	Inches		Millimeters		Inches	Millimeters
		Max.	Min.	Max.	Min.		
3/8 thru 5/8	3.18 thru 4.76	0.094	0.090	2.39	2.29	3/16	7.0
over 5/8 thru 3/4	over 4.76 thru 6.35	0.122	0.118	3.10	3.00	3/16	8.0
over 3/4 thru 7/8	over 6.35 thru 7.94	0.162	0.158	4.11	4.01	3/16	8.5
over 7/8 thru 1 1/8	over 7.94 thru 9.53	0.203	0.199	5.16	5.06	3/16	9.5
over 1 1/8 thru 1 1/4	over 9.53 thru 11.91	0.243	0.239	6.17	6.07	3/16	11.0
over 1 1/4 thru 1 3/8	over 11.91 thru 14.29	0.303	0.297	7.70	7.55	1/2	12.5
over 1 3/8 thru 1 1/2	over 14.29 thru 16.67	0.373	0.367	9.47	9.32	3/8	14.5
over 1 1/2 thru 1 5/8	over 16.67 thru 19.05	0.443	0.437	11.25	11.10	3/8	16.0
over 1 5/8 thru 1 3/4	over 19.05 thru 22.23	0.514	0.508	13.05	12.90	1/2	17.5
over 1 3/4 thru 1 7/8	over 22.23 thru 25.40	0.609	0.601	15.47	15.27	3/4	19.0
over 1 thru 1 1/2	over 25.40 thru 30.16	0.700	0.692	17.78	17.58	1/2	20.5
over 1 7/8 thru 1 3/4	over 30.16 thru 34.93	0.817	0.809	20.75	20.55	3/4	22.0

To fit split sleeve collet type drill drivers. See page 850.

Table 10. American National Standard Straight Shank Twist Drills — Screw Machine Length — Over 1 in. (25.4 mm) Dia. ANS/ASME B94.11M-1993

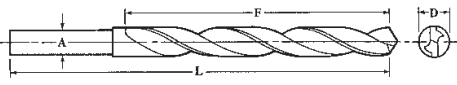

Diameter of Drill				Flute Length		Overall Length		Shank Diameter	
D		Decimal Inch Equivalent	Millimeter Equivalent	F		L		A	
Frac.	mm			Inch	mm	Inch	mm	Inch	mm
	25.50	1.0039	25.500	4	102	6	152	0.9843	25.00
	26.00	1.0236	26.000	4	102	6	152	0.9843	25.00
1/16		1.0625	26.988	4	102	6	152	1.0000	25.40
	28.00	1.1024	28.000	4	102	6	152	0.9843	25.00
1/8		1.1250	28.575	4	102	6	152	1.0000	25.40
	30.00	1.1811	30.000	4 1/2	108	6 3/8	168	0.9843	25.00
3/16		1.1875	30.162	4 1/4	108	6 1/4	168	1.0000	25.40
1/4		1.2500	31.750	4 3/8	111	6 1/2	171	1.0000	25.40
	32.00	1.2598	32.000	4 1/2	111	7	178	1.2402	31.50
5/16		1.3125	33.338	4 3/4	111	7	178	1.2500	31.75
	34.00	1.3386	34.000	4 1/2	114	7 1/8	181	1.2402	31.50
3/8		1.3750	34.925	4 3/4	114	7 1/2	181	1.2500	31.75
	36.00	1.4173	36.000	4 3/4	121	7 3/8	187	1.2402	31.50
7/16		1.4375	36.512	4 3/4	121	7 3/8	187	1.2500	31.75
	38.00	1.4961	38.000	4 3/4	124	7 1/2	190	1.2402	31.50
1/2		1.5000	38.100	4 3/4	124	7 1/2	190	1.2500	31.75
9/16		1.5625	39.688	4 3/4	124	7 1/2	197	1.5000	38.10
	40.00	1.5748	40.000	4 3/8	124	7 3/4	197	1.4961	38.00
5/8		1.6250	41.275	4 3/4	124	7 3/4	197	1.5000	38.10
	42.00	1.6535	42.000	5 1/4	130	8	203	1.4961	38.00
11/16		1.6875	42.862	5 1/4	130	8	203	1.5000	38.10
	44.00	1.7323	44.000	5 1/4	130	8	203	1.4961	38.00
3/4		1.7500	44.450	5 1/4	130	8	203	1.5000	38.10
	46.00	1.8110	46.000	5 1/4	137	8 1/2	210	1.4961	38.00
13/16		1.8125	46.038	5 1/4	137	8 1/2	210	1.5000	38.10
7/8		1.8750	47.625	5 1/4	137	8 1/2	210	1.5000	38.10
	48.00	1.8898	48.000	5 1/2	143	8 1/2	216	1.4961	38.00
15/16		1.9375	49.212	5 1/2	143	8 1/2	216	1.5000	38.10
	50.00	1.9685	50.000	5 1/2	143	8 1/2	216	1.4961	38.00
2		2.0000	50.800	5 1/2	143	8 1/2	216	1.5000	38.10

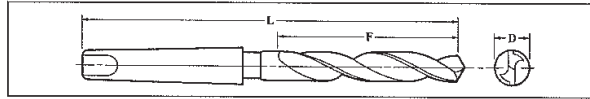

Table 11. American National Taper Shank Twist Drills—Fractional and Metric Sizes ANS/ASME B94.11M-1993

Frac-tion	Drill Diameter, D			Morse Taper No.	Regular Shank				Morse Taper No.	Larger or Smaller Shank <sup>a</sup>			
	Equivalent				Flute Length		Overall Length			Flute Length		Overall Length	
	mm	Deci. Inch	mm		Inch	mm	Inch	mm		Inch	mm	Inch	mm
1/8	3.00	0.1181	3.000	1	1 1/2	48	5 1/2	130	...	...	...	...	
		0.1250	3.175	1	1 3/8	48	5 1/2	130	...	...	...	...	
	3.20	0.1260	3.200	1	2 1/8	54	5 3/8	137	...	...	...	...	
3/16	3.50	0.1378	3.500	1	2 1/4	54	5 3/8	137	...	...	...	...	
		0.1406	3.571	1	2 1/4	54	5 3/8	137	...	...	...	...	
	3.80	0.1496	3.800	1	2 1/2	54	5 3/8	137	...	...	...	...	
1/4	4.00	0.1562	3.967	1	2 1/2	54	5 3/8	137	...	...	...	...	
		0.1575	4.000	1	2 1/2	64	5 3/4	146	...	...	...	...	
	4.20	0.1654	4.200	1	2 1/2	64	5 3/4	146	...	...	...	...	
5/16	4.50	0.1719	4.366	1	2 1/2	64	5 3/4	146	...	...	...	...	
		0.1772	4.500	1	2 1/2	64	5 3/4	146	...	...	...	...	
	4.80	0.1875	4.762	1	2 1/2	64	5 3/4	146	...	...	...	...	
3/8	5.00	0.1890	4.800	1	2 3/8	70	6	152	...	...	...	...	
		0.1969	5.000	1	2 3/8	70	6	152	...	...	...	...	
	5.20	0.2031	5.159	1	2 3/8	70	6	152	...	...	...	...	
7/16	5.50	0.2047	5.200	1	2 3/8	70	6	152	...	...	...	...	
		0.2165	5.500	1	2 3/8	70	6	152	...	...	...	...	
	5.80	0.2183	5.558	1	2 3/8	70	6	152	...	...	...	...	
1/2	6.00	0.2223	5.800	1	2 3/4	73	6 1/2	156	...	...	...	...	
		0.2344	5.954	1	2 3/4	73	6 1/2	156	...	...	...	...	
	6.20	0.2362	6.000	1	2 3/4	73	6 1/2	156	...	...	...	...	
5/8	6.50	0.2441	6.200	1	2 3/4	73	6 1/2	156	...	...	...	...	
		0.2500	6.350	1	2 3/4	73	6 1/2	156	...	...	...	...	
	6.80	0.2539	6.500	1	3	76	6 1/2	159	...	...	...	...	
3/4	7.00	0.2656	6.746	1	3	76	6 1/2	159	...	...	...	...	
		0.2677	6.800	1	3	76	6 1/2	159	...	...	...	...	
	7.20	0.2756	7.000	1	3	76	6 1/2	159	...	...	...	...	
7/8	7.50	0.2812	7.142	1	3	76	6 1/2	159	...	...	...	...	
		0.2835	7.200	1	3 1/2	79	6 3/4	162	...	...	...	...	
	7.80	0.2933	7.500	1	3 1/2	79	6 3/4	162	...	...	...	...	
1 1/8	8.00	0.2969	7.541	1	3 1/2	79	6 3/4	162	...	...	...	...	
		0.3071	7.800	1	3 1/2	79	6 3/4	162	...	...	...	...	
	8.20	0.3125	7.938	1	3 1/2	79	6 3/4	162	...	...	...	...	
1 1/4	8.50	0.3150	8.000	1	3 1/2	83	6 1/2	165	...	...	...	...	
		0.3228	8.200	1	3 1/2	83	6 1/2	165	...	...	...	...	
	8.80	0.3281	8.334	1	3 1/2	83	6 1/2	165	...	...	...	...	
1 3/8	9.00	0.3346	8.500	1	3 1/2	83	6 1/2	165	...	...	...	...	
		0.3438	8.733	1	3 1/2	83	6 1/2	165	...	...	...	...	
	9.20	0.3465	8.800	1	3 1/2	89	6 1/2	171	...	...	...	...	
1 1/2	9.50	0.3543	9.000	1	3 1/2	89	6 1/2	171	...	...	...	...	
		0.3594	9.129	1	3 1/2	89	6 1/2	171	...	...	...	...	
	9.80	0.3622	9.200	1	3 1/2	89	6 1/2	171	...	...	...	...	
1 3/4	10.00	0.3740	9.500	1	3 1/2	89	6 1/2	171	...	...	...	...	
		0.3750	9.525	1	3 1/2	89	6 1/2	171	2	3 1/2	89	7 3/4	187
	10.50	0.3858	9.800	1	3 3/4	92	7	178	...	...	...	...	
1 7/8	10.80	0.3906	9.921	1	3 3/4	92	7	178	2	3 3/4	92	7 1/2	190
		0.3937	10.000	1	3 3/4	92	7	178	...	...	...	...	

Table 11. (Continued) American National Taper Shank Twist Drills—Fractional and Metric Sizes ANSI/ASME B94.11M-1993

Frac- tion	Drill Diameter, D			Regular Shank				Larger or Smaller Shank*				
	mm	Equivalent		Morse Taper No.	Flute Length F		Overall Length L		Flute Length F		Overall Length L	
		Deci. Inch	mm		Inch	mm	Inch	mm	Inch	mm	Inch	mm
1/32	10.20	0.4016	10.200	1	3 3/8	92	7	178	...	...	...	...
		0.4062	10.320	1	3 3/8	92	7	178	2	3 3/8	92	190
7/64	10.50	0.4134	10.500	1	3 3/8	98	7 1/4	184	...	...	...	...
		0.4219	10.716	1	3 3/8	98	7 1/4	184	2	3 3/8	98	197
3/16	10.80	0.4252	10.800	1	3 3/8	98	7 1/4	184	...	...	...	...
		0.4331	11.000	1	3 3/8	98	7 1/4	184	2	3 3/8	98	197
1/4	11.20	0.4375	11.112	1	3 3/8	98	7 1/4	184	...	...	...	...
		0.4409	11.200	1	4 1/8	105	7 1/2	190	...	...	...	...
5/16	11.50	0.4528	11.500	1	4 1/8	105	7 1/2	190	...	...	...	...
		0.4531	11.509	1	4 1/8	105	7 1/2	190	2	4 1/8	105	203
3/8	11.80	0.4646	11.800	1	4 1/8	105	7 1/2	190	...	...	...	...
		0.4688	11.906	1	4 1/8	105	7 1/2	190	2	4 1/8	105	203
7/16	12.00	0.4734	12.000	2	4 3/8	111	8 1/4	210	1	4 3/8	111	197
		0.4803	12.200	2	4 3/8	111	8 1/4	210	1	4 3/8	111	197
1/2	12.20	0.4844	12.304	2	4 3/8	111	8 1/4	210	1	4 3/8	111	197
		0.4921	12.500	2	4 3/8	111	8 1/4	210	1	4 3/8	111	197
5/8	12.50	0.5000	12.700	2	4 3/8	111	8 1/4	210	1	4 3/8	117	203
		0.5034	12.800	2	4 3/8	117	8 1/2	216	1	4 3/8	117	203
3/4	13.00	0.5118	13.000	2	4 3/8	117	8 1/4	216	1	4 3/8	117	203
		0.5156	13.096	2	4 3/8	117	8 1/4	216	1	4 3/8	117	203
7/8	13.20	0.5197	13.200	2	4 3/8	117	8 1/4	216	1	4 3/8	117	203
		0.5312	13.492	2	4 3/8	117	8 1/4	216	1	4 3/8	117	203
1 1/16	13.50	0.5315	13.500	2	4 3/8	117	8 1/4	216	1	4 3/8	124	210
		0.5433	13.800	2	4 3/8	124	8 3/4	222	1	4 3/8	124	210
1 1/8	14.00	0.5469	13.891	2	4 3/8	124	8 3/4	222	1	4 3/8	124	210
		0.5572	14.000	2	4 3/8	124	8 3/4	222	1	4 3/8	124	210
1 1/4	14.25	0.5610	14.250	2	4 3/8	124	8 3/4	222	1	4 3/8	124	210
		0.5625	14.288	2	4 3/8	124	8 3/4	222	1	4 3/8	124	210
1 3/8	14.50	0.5709	14.500	2	4 3/8	124	8 3/4	222	...	...	...	...
		0.5781	14.684	2	4 3/8	124	8 3/4	222	...	...	...	...
1 1/2	14.75	0.5807	14.750	2	4 3/8	124	8 3/4	222	...	...	...	...
		0.5906	15.000	2	4 3/8	124	8 3/4	222	...	...	...	...
1 5/8	15.00	0.5938	15.083	2	4 3/8	124	8 3/4	222	...	...	...	...
		0.6094	15.250	2	4 3/8	124	8 3/4	222	...	...	...	...
1 3/4	15.25	0.6094	15.250	2	4 3/8	124	8 3/4	222	...	...	...	...
		0.6102	15.500	2	4 3/8	124	8 3/4	222	...	...	...	...
1 7/8	15.50	0.6102	15.500	2	4 3/8	124	8 3/4	222	...	...	...	...
		0.6201	15.750	2	4 3/8	124	8 3/4	222	...	...	...	...
2	15.75	0.6250	15.875	2	4 3/8	124	8 3/4	222	...	...	...	...
		0.6299	16.000	2	5 1/8	130	9	229	...	...	...	...
2 1/8	16.00	0.6299	16.250	2	5 1/8	130	9	229	...	...	...	...
		0.6406	16.371	2	5 1/8	130	9	229	3	5 1/8	130	248
2 1/4	16.25	0.6406	16.500	2	5 1/8	130	9	229	...	...	...	...
		0.6502	16.667	2	5 1/8	130	9	229	3	5 1/8	130	248
2 3/8	16.50	0.6594	16.750	2	5 3/8	137	9 1/4	235	...	...	...	...
		0.6693	17.000	2	5 3/8	137	9 1/4	235	...	...	...	...
2 1/2	17.00	0.6719	17.066	2	5 3/8	137	9 1/4	235	3	5 3/8	137	254
		0.6791	17.250	2	5 3/8	137	9 1/4	235	...	...	...	...
2 5/8	17.25	0.6791	17.250	2	5 3/8	137	9 1/4	235	...	...	...	...
		0.6875	17.462	2	5 3/8	137	9 1/4	235	3	5 3/8	137	254
2 3/4	17.50	0.6880	17.500	2	5 3/8	143	9 1/2	241	...	...	...	...
		0.7031	17.859	2	5 3/8	143	9 1/2	241	3	5 3/8	143	260
3	18.00	0.7087	18.000	2	5 3/8	143	9 1/2	241	...	...	...	...
		0.7188	18.258	2	5 3/8	143	9 1/2	241	3	5 3/8	143	260
3 1/8	18.50	0.7283	18.500	2	5 3/8	149	9 3/4	248	...	...	...	...
		0.7344	18.654	2	5 3/8	149	9 3/4	248	3	5 3/8	149	267

Table 11. (Continued) American National Taper Shank Twist Drills — Fractional and Metric Sizes ANS/ASME B94.11M-1993

Frac- tion	Drill Diameter, D				Regular Shank				Larger or Smaller Shank*				
	Equivalent		Morse Taper No.	Flute Length F		Overall Length L		Flute Length F		Overall Length L			
	Deci. Inch	mm		Inch	mm	Inch	mm	Inch	mm	Inch	mm		
	mm												
3/4	19.00	0.7480	19.000	2	5 1/8	149	9 1/4	248	...	...	...	...	
		0.7500	19.050	2	5 1/8	149	9 1/4	248	3	5 7/8	149	10 1/2	267
7/8		0.7656	19.446	2	6	152	9 3/4	251	3	6	152	10 3/4	270
	19.50	0.7677	19.500	2	6	152	9 3/4	251	...	...	...	...	
1 1/16		0.7812	19.843	2	6	152	9 3/4	251	3	6	152	10 3/4	270
	20.00	0.7821	20.000	3	6 1/8	156	10 1/2	273	2	6 1/8	156	10	254
1 1/8		0.7969	20.241	3	6 1/8	156	10 1/2	273	2	6 1/8	156	10	254
	20.50	0.8071	20.500	3	6 1/8	156	10 1/2	273	2	6 1/8	156	10	254
1 1/4		0.8125	20.638	3	6 1/8	156	10 1/2	273	2	6 1/8	156	10	254
	21.00	0.8268	21.000	3	6 1/8	156	10 1/2	273	2	6 1/8	156	10	254
1 3/8		0.8281	21.094	3	6 1/8	156	10 1/2	273	2	6 1/8	156	10	254
	21.50	0.8438	21.433	3	6 1/8	156	10 1/2	273	2	6 1/8	156	10	254
1 1/2		0.8465	21.500	3	6 1/8	156	10 1/2	273	2	6 1/8	156	10	254
	22.00	0.8594	21.829	3	6 1/8	156	10 1/2	273	2	6 1/8	156	10	254
1 5/8		0.8661	22.000	3	6 1/8	156	10 1/2	273	2	6 1/8	156	10	254
	22.50	0.8750	22.225	3	6 1/8	156	10 1/2	273	2	6 1/8	156	10	254
1 3/4		0.8838	22.500	3	6 1/8	156	10 1/2	273	2	6 1/8	156	10	254
	23.00	0.8906	22.621	3	6 1/8	156	10 1/2	273	2	6 1/8	156	10	254
1 7/8		0.9055	23.000	3	6 1/8	156	10 1/2	273	2	6 1/8	156	10	254
	23.50	0.9062	23.017	3	6 1/8	156	10 1/2	273	2	6 1/8	156	10	254
2		0.9219	23.416	3	6 1/8	156	10 1/2	273	...	...	...	...	
	24.00	0.9252	23.500	3	6 1/8	156	10 1/2	273	...	...	...	...	
2 1/8		0.9375	23.813	3	6 1/8	156	10 1/2	273	...	...	...	...	
	24.50	0.9449	24.000	3	6 1/8	162	11	279	...	...	...	...	
2 1/4		0.9531	24.209	3	6 1/8	162	11	279	...	...	...	...	
	25.00	0.9646	24.500	3	6 1/8	162	11	279	...	...	...	...	
2 3/8		0.9688	24.608	3	6 1/8	162	11	279	...	...	...	...	
	25.50	0.9843	25.000	3	6 1/8	162	11	279	...	...	...	...	
2 1/2		0.9844	25.004	3	6 1/8	162	11	279	...	...	...	...	
	26.00	1.0000	25.400	3	6 1/2	165	11 1/2	283	...	...	...	...	
2 3/4		1.0156	25.796	3	6 1/2	165	11 1/2	283	...	...	...	...	
	26.50	1.0236	26.000	3	6 1/2	165	11 1/2	283	...	...	...	...	
3		1.0312	26.192	3	6 1/2	165	11 1/2	283	4	6 1/2	165	12 3/4	308
	27.00	1.0433	26.500	3	6 3/8	168	11 3/4	286	...	...	...	...	
3 1/8		1.0469	26.591	3	6 3/8	168	11 3/4	286	...	...	...	...	
	27.50	1.0625	26.988	3	6 3/8	168	11 3/4	286	4	6 3/8	168	12 3/4	311
3 1/4		1.0630	27.000	3	6 3/8	168	11 3/4	286	...	...	...	...	
	28.00	1.0781	27.384	4	6 3/8	175	12 1/2	318	3	6 3/8	175	11 3/4	292
3 1/2		1.0827	27.500	4	6 3/8	175	12 1/2	318	3	6 3/8	175	11 3/4	292
	28.50	1.0938	27.783	4	6 3/8	175	12 1/2	318	3	6 3/8	175	11 3/4	292
3 3/8		1.1024	28.000	4	7 1/8	181	12 3/4	324	3	7 1/8	181	11 3/4	298
	29.00	1.1094	28.179	4	7 1/8	181	12 3/4	324	3	7 1/8	181	11 3/4	298
3 1/2		1.1220	28.500	4	7 1/8	181	12 3/4	324	3	7 1/8	181	11 3/4	298
	28.50	1.1250	28.575	4	7 3/8	181	12 3/4	324	3	7 3/8	181	11 3/4	298
3 3/4		1.1406	28.971	4	7 3/8	184	12 3/4	327	3	7 3/8	184	11 3/4	302
	29.50	1.1417	29.000	4	7 3/8	184	12 3/4	327	3	7 3/8	184	11 3/4	302
3 7/8		1.1562	29.367	4	7 3/8	184	12 3/4	327	3	7 3/8	184	11 3/4	302
	30.00	1.1614	29.500	4	7 3/8	187	13	330	3	7 3/8	187	12	305
4		1.1719	29.797	4	7 3/8	187	13	330	3	7 3/8	187	12	305
	30.50	1.1811	30.000	4	7 3/8	187	13	330	3	7 3/8	187	12	305
4 1/8		1.1875	30.162	4	7 3/8	187	13	330	3	7 3/8	187	12	305
	31.00	1.2008	30.500	4	7 1/2	190	13 1/2	333	3	7 1/2	190	12 1/2	308
4 1/4		1.2031	30.559	4	7 1/2	190	13 1/2	333	3	7 1/2	190	12 1/2	308

Table 11. (Continued) American National Taper Shank Twist Drills — Fractional and Metric Sizes ANS/ASME B94.11M-1993

Drill Diameter, D				Regular Shank				Larger or Smaller Shank*					
Frac- tion	mm	Equivalent		Morse Taper No.	Flute Length F		Overall Length L		Morse Taper No.	Flute Length F		Overall Length L	
		Deci. inch	mm		Inch	mm	Inch	mm		Inch	mm		
1 1/32	31.00	1.2188	30.958	4	7 1/2	190	13 1/2	333	3	7 1/2	190	12 1/4	308
		1.2205	31.000	4	7 1/2	200	13 1/2	343	3	7 1/2	200	12 1/2	318
1 1/16	31.50	1.2344	31.354	4	7 3/8	200	13 1/2	343	3	7 3/8	200	12 1/2	318
		1.2402	31.500	4	7 3/8	200	13 1/2	343	3	7 3/8	200	12 1/2	318
1/4	32.00	1.2500	31.750	4	7 7/8	200	13 3/4	343	3	7 7/8	200	12 1/2	318
		1.2598	32.000	4	8 1/2	216	14 1/4	359	...	...	...	...	...
1 1/8	32.50	1.2656	32.146	4	8 1/2	216	14 1/4	359	...	...	...	...	...
		1.2795	32.500	4	8 1/2	216	14 1/4	359	...	...	...	...	...
1 3/16	33.00	1.2812	32.542	4	8 1/2	216	14 1/4	359	...	...	...	...	...
		1.2969	32.941	4	8 3/8	219	14 1/4	362	...	...	...	...	...
1 1/4	33.50	1.2992	33.000	4	8 3/8	219	14 1/4	362	...	...	...	...	...
		1.3125	33.338	4	8 3/8	219	14 1/4	362	...	...	...	...	...
1 1/2	34.00	1.3189	33.500	4	8 7/8	222	14 3/8	365	...	...	...	...	...
		1.3281	33.734	4	8 7/8	222	14 3/8	365	...	...	...	...	...
1 3/8	34.50	1.3366	34.000	4	8 7/8	222	14 3/8	365	...	...	...	...	...
		1.3438	34.133	4	8 7/8	222	14 3/8	365	...	...	...	...	...
1 1/2	34.50	1.3583	34.500	4	8 7/8	225	14 3/8	368	...	...	...	...	...
		1.3594	34.529	4	8 7/8	225	14 3/8	368	...	...	...	...	...
1 3/4	35.00	1.3750	34.925	4	8 7/8	225	14 3/8	368	...	...	...	...	...
		1.3780	35.000	4	9	229	14 3/8	371	...	...	...	...	...
1 1/4	35.00	1.3906	35.321	4	9	229	14 3/8	371	...	...	...	...	...
		1.3976	35.500	4	9	229	14 3/8	371	...	...	...	...	...
1 1/2	35.50	1.4062	35.717	4	9	229	14 3/8	371	...	...	...	...	...
		1.4173	36.000	4	9 1/2	232	14 3/8	375	...	...	...	...	...
1 3/8	36.00	1.4219	36.116	4	9 1/2	232	14 3/8	375	...	...	...	...	...
		1.4370	36.500	4	9 1/2	232	14 3/8	375	...	...	...	...	...
1 1/2	36.50	1.4375	36.512	4	9 1/2	232	14 3/8	375	...	...	...	...	...
		1.4531	36.909	4	9 1/2	235	14 3/8	378	...	...	...	...	...
1 3/4	37.00	1.4567	37.000	4	9 1/2	235	14 3/8	378	...	...	...	...	...
		1.4688	37.308	4	9 1/2	235	14 3/8	378	...	...	...	...	...
1 1/2	37.50	1.4764	37.500	4	9 3/4	238	15	381	...	...	...	...	...
		1.4844	37.704	4	9 3/4	238	15	381	...	...	...	...	...
1 3/4	38.00	1.4961	38.000	4	9 3/4	238	15	381	...	...	...	...	...
		1.5000	38.100	4	9 3/4	238	15	381	...	...	...	...	...
1 1/2	38.00	1.5156	38.496	...	...	...	...	...	4	9 3/4	238	15	381
		1.5312	38.892	5	9 3/4	238	16 1/8	416	4	9 3/4	238	15	381
1 3/8	39.00	1.5354	39.000	5	9 3/4	244	16 1/8	422	4	9 3/4	244	15 1/2	387
		1.5469	39.291	...	...	...	...	...	4	9 3/4	244	15 1/2	387
1 1/4	39.00	1.5625	39.688	5	9 3/4	244	16 1/8	422	4	9 3/4	244	15 1/2	387
		1.5748	40.000	5	9 3/4	251	16 1/8	429	4	9 3/4	251	15 3/4	394
1 1/2	40.00	1.5781	40.084	...	...	...	...	...	4	9 3/4	251	15 3/4	394
		1.5928	40.483	5	9 3/4	251	16 1/8	429	4	9 3/4	251	15 3/4	394
1 3/8	40.00	1.6064	40.879	...	...	...	...	...	4	10	254	15 3/4	397
		1.6142	41.000	5	10	254	17	432	4	10	254	15 3/4	397
1 1/2	41.00	1.6250	41.275	5	10	254	17	432	4	10	254	15 3/4	397
		1.6406	41.671	...	...	...	...	...	4	10 1/2	257	15 3/4	400
1 3/4	42.00	1.6535	42.000	5	10 1/2	257	17 1/2	435	4	10 1/2	257	15 3/4	400
		1.6562	42.067	5	10 1/2	257	17 1/2	435	4	10 1/2	257	15 3/4	400
1 1/2	42.00	1.6719	42.466	...	...	...	...	...	4	10 1/2	257	15 3/4	400
		1.6875	42.862	5	10 1/2	257	17 1/2	435	4	10 1/2	257	15 3/4	400
1 3/8	43.00	1.6929	43.000	5	10 3/4	257	17 3/4	435	4	10 3/4	257	15 3/4	400
		1.7031	43.259	...	...	...	...	...	4	10 3/4	257	15 3/4	400
1 1/2	43.00	1.7188	43.658	5	10 3/4	257	17 3/4	435	4	10 3/4	257	15 3/4	400
		1.7323	44.000	5	10 3/4	257	17 3/4	435	4	10 3/4	264	16 1/4	413

Table 11. (Continued) American National Taper Shank Twist Drills — Fractional and Metric Sizes ANS/ASME B94.11M-1993

Frac- tion	Drill Diameter, D				Morse Taper No.	Regular Shank				Morse Taper No.	Larger or Smaller Shank*			
	mm	Equivalent		F		Flute Length		L	F		Flute Length		L	
		Deci. Inch	mm			Inch	mm				Inch	mm		
1/16	1.7344	44.054	...	...	...	...	...	4	10 1/2	264	16 1/2	413		
1/8	1.7500	44.450	5	10 1/2	257	17 1/2	435	4	10 1/2	264	16 1/2	413		
	45.00	1.7717	45.000	5	10 1/2	257	17 1/2	435	4	10 1/2	264	16 1/2	413	
1/4	1.7812	45.242	5	10 1/2	257	17 1/2	435	4	10 1/2	264	16 1/2	413		
	46.00	1.8110	46.000	5	10 1/2	257	17 1/2	435	4	10 1/2	264	16 1/2	413	
3/8	1.8125	46.038	5	10 1/2	257	17 1/2	435	4	10 1/2	264	16 1/2	413		
1/2	1.8438	46.833	5	10 1/2	257	17 1/2	435	4	10 1/2	264	16 1/2	413		
	47.00	1.8504	47.000	5	10 1/2	264	17 1/2	441	4	10 1/2	267	16 1/2	419	
3/4	1.8750	47.625	5	10 1/2	264	17 1/2	441	4	10 1/2	267	16 1/2	419		
	48.00	1.8898	48.000	5	10 1/2	264	17 1/2	441	4	10 1/2	267	16 1/2	419	
1 1/8	1.9062	48.417	5	10 1/2	264	17 1/2	441	4	10 1/2	267	16 1/2	419		
1 1/4	1.9291	49.000	5	10 1/2	264	17 1/2	441	4	10 1/2	270	16 1/2	422		
1 3/8	1.9375	49.212	5	10 1/2	264	17 1/2	441	4	10 1/2	270	16 1/2	422		
1 1/2	1.9625	50.000	5	10 1/2	264	17 1/2	441	4	10 1/2	270	16 1/2	422		
1 3/4	1.9688	50.008	5	10 1/2	264	17 1/2	441	4	10 1/2	270	16 1/2	422		
2	2.0000	50.800	5	10 1/2	264	17 1/2	441	4	10 1/2	270	16 1/2	422		
	51.00	2.0079	51.000	5	10 1/2	264	17 1/2	441	...	...	...	...		
2 1/8	2.0312	51.592	5	10 1/2	264	17 1/2	441	...	...	...	...	...		
2 1/4	2.0472	52.000	5	10 1/2	260	17 1/2	441	...	...	...	...	...		
2 3/8	2.0625	52.388	5	10 1/2	260	17 1/2	441	...	...	...	...	...		
2 1/2	2.0866	53.000	5	10 1/2	260	17 1/2	441	...	...	...	...	...		
2 3/4	2.0938	53.183	5	10 1/2	260	17 1/2	441	...	...	...	...	...		
3	2.1250	53.975	5	10 1/2	260	17 1/2	441	...	...	...	...	...		
	54.00	2.1260	54.000	5	10 1/2	260	17 1/2	441	...	...	...	...		
3 1/8	2.1562	54.767	5	10 1/2	260	17 1/2	441	...	...	...	...	...		
3 1/4	2.1654	55.000	5	10 1/2	260	17 1/2	441	...	...	...	...	...		
3 3/8	2.1875	55.563	5	10 1/2	260	17 1/2	441	...	...	...	...	...		
3 1/2	2.2000	56.000	5	10 1/2	257	17 1/2	441	...	...	...	...	...		
3 3/4	2.2188	56.358	5	10 1/2	257	17 1/2	441	...	...	...	...	...		
4	2.2441	57.000	5	10 1/2	257	17 1/2	441	...	...	...	...	...		
	58.00	2.2500	57.150	5	10 1/2	257	17 1/2	441	...	...	...	...		
4 1/8	2.2835	58.000	5	10 1/2	257	17 1/2	441	...	...	...	...	...		
4 1/4	2.3125	58.738	5	10 1/2	257	17 1/2	441	...	...	...	...	...		
4 3/8	2.3228	59.000	5	10 1/2	257	17 1/2	441	...	...	...	...	...		
4 1/2	2.3622	60.000	5	10 1/2	257	17 1/2	441	...	...	...	...	...		
4 3/4	2.3750	60.325	5	10 1/2	257	17 1/2	441	...	...	...	...	...		
5	2.4016	61.000	5	11 1/2	286	18 1/2	476	...	...	...	...	...		
	61.00	2.4375	61.912	5	11 1/2	286	18 1/2	476	...	...	...	...		
5 1/8	2.4409	62.000	5	11 1/2	286	18 1/2	476	...	...	...	...	...		
5 1/4	2.4803	63.000	5	11 1/2	286	18 1/2	476	...	...	...	...	...		
5 3/8	2.5000	63.500	5	11 1/2	286	18 1/2	476	...	...	...	...	...		
5 1/2	2.5197	64.000	5	11 1/2	302	19 1/2	495	...	...	...	...	...		
5 3/4	2.5591	65.000	5	11 1/2	302	19 1/2	495	...	...	...	...	...		
6	2.5625	65.088	5	11 1/2	302	19 1/2	495	...	...	...	...	...		
	66.00	2.5984	66.000	5	11 1/2	302	19 1/2	495	...	...	...	...		
6 1/8	2.6250	66.675	5	11 1/2	302	19 1/2	495	...	...	...	...	...		
6 1/4	2.6378	67.000	5	12 1/2	324	20 1/2	518	...	...	...	...	...		
6 3/8	2.6772	68.000	5	12 1/2	324	20 1/2	518	...	...	...	...	...		
6 1/2	2.6875	68.262	5	12 1/2	324	20 1/2	518	...	...	...	...	...		
6 3/4	2.7165	69.000	5	12 1/2	324	20 1/2	518	...	...	...	...	...		
7	2.7500	69.850	5	12 1/2	324	20 1/2	518	...	...	...	...	...		
	70.00	2.7559	70.000	5	13 1/2	340	21 1/2	537	...	...	...	...		
7 1/8	2.7953	71.000	5	13 1/2	340	21 1/2	537	...	...	...	...	...		
7 1/4	2.8125	71.438	5	13 1/2	340	21 1/2	537	...	...	...	...	...		



Table 11. (Continued) American National Taper Shank Twist Drills --- Fractional and Metric Sizes ANS/ASME B94.11M-1993

Frac-tion	Drill Diameter, D			Morse Taper No.	Regular Shank				Larger or Smaller Shank*				
	Equivalent				Flute Length F		Overall Length L		Flute Length F		Overall Length L		
	mm	Deci. Inch	mm		Inch	mm	Inch	mm	Inch	mm	Inch	mm	
2 3/8	72.00	2.8346	72.000	5	13 1/2	340	21 1/2	537	...	...	...	...	
	73.00	2.8740	73.000	5	13 3/4	340	21 1/2	537	...	...	...	...	
	74.00	2.9134	74.000	5	14	356	21 3/4	552	...	...	...	...	
2 1/2	75.00	2.9375	74.612	5	14	356	21 3/4	552	...	...	...	...	
	76.00	2.9528	75.000	5	14	356	21 3/4	552	...	...	...	...	
	76.00	2.9921	76.000	5	14	356	21 3/4	552	...	...	...	...	
3	77.00	3.0000	76.200	5	14	356	21 3/4	552	...	...	...	...	
	77.00	3.0315	77.000	6	14 1/2	371	24 1/2	622	5	14 1/2	362	22	559
	78.00	3.0709	78.000	6	14 3/4	371	24 1/2	622	5	14 3/4	362	22	559
3 1/2	78.00	3.1250	79.375	6	14 3/4	371	24 1/2	622	5	14 3/4	362	22	559
	78.00	3.2500	82.550	6	15 1/2	394	25 1/2	648	5	15 1/2	387	23	584
3 3/4	78.00	3.5000	88.900	...	...	...	...	...	5	16 1/2	413	24	610

\*Larger or smaller than regular shank.

Table 12. American National Standard Combined Drills and Countersinks --- Plain and Bell Types ANS/ASME B94.11M-1993

PLAIN TYPE

BELL TYPE

Size Designation	Body Diameter		Drill Diameter		Drill Length		Overall Length	
	A		D		C		L	
	Inches	Millimeters	Inches	Millimeters	Inches	Millimeters	Inches	Millimeters
00	1/8	3.18	.025	0.64	.030	0.76	1 1/8	29
0	1/8	3.18	1/32	0.79	.038	0.97	1 1/8	29
1	1/8	3.18	3/64	1.19	3/64	1.19	1 1/4	32
2	3/16	4.76	3/64	1.98	3/64	1.98	1 3/8	48
3	1/4	6.35	3/64	2.78	3/64	2.78	2	51
4	5/16	7.94	1/8	3.18	1/8	3.18	2 1/8	54
5	3/8	11.11	3/16	4.76	3/16	4.76	2 3/8	70
6	1/2	12.70	7/32	5.56	7/32	5.56	3	76
7	5/8	15.88	1/2	6.35	1/2	6.35	3 1/2	83
8	3/4	19.05	5/8	7.94	5/8	7.94	3 3/4	89

  

Size Designation	Body Diameter		Drill Diameter		Bell Diameter		Drill Length		Overall Length	
	A		D		E		C		L	
	Inches	mm	Inches	mm	Inches	mm	Inches	mm	Inches	mm
11	1/4	3.18	3/64	1.19	0.10	2.5	3/64	1.19	1 1/2	32
12	3/16	4.76	1/16	1.59	0.15	3.8	1/16	1.59	1 3/8	48
13	1/4	6.35	3/32	2.38	0.20	5.1	3/32	2.38	2	51
14	5/16	7.94	1/16	2.78	0.25	6.4	1/16	2.78	2 1/8	54
15	3/8	11.11	5/64	3.97	0.35	8.9	5/64	3.97	2 3/8	70
16	1/2	12.70	3/16	4.76	0.40	10.2	3/16	4.76	3	76
17	5/8	15.88	7/32	5.56	0.50	12.7	7/32	5.56	3 1/2	83
18	3/4	19.05	1/2	6.35	0.60	15.2	1/2	6.35	3 3/4	89

**Table 13. American National Standard Three- and Four-Flute Taper Shank Core Drills — Fractional Sizes Only ANS/ASME B94.11M-1993**

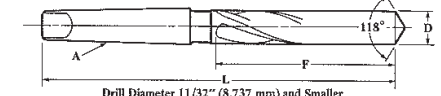

Drill Diameter 11/32" (8.737 mm) and Smaller



Drill Diameter 3/8" (9.525 mm) and Larger

Drill Diameter, D			Three-Flute Drills				Four-Flute Drills					
Inch	Equivalent		Morse Taper No.	Flute Length		Overall Length		Morse Taper No.	Flute Length		Overall Length	
	Deci. Inch	mm		F	L	F	L		F	L		
1/4	0.2500	6.350	1	2 3/4	73	6 1/4	156	...	...	...	...	
5/16	0.3125	7.938	1	3	76	6 3/4	159	...	...	...	...	
3/8	0.3750	9.525	1	3 1/2	83	6 3/4	165	...	...	...	...	
7/16	0.4375	11.112	1	3 3/4	98	7 1/4	184	...	...	...	...	
1/2	0.5000	12.700	2	4 1/2	111	8 1/4	210	2	4 1/2	111	8 1/2	
9/16	0.5625	14.288	2	4 3/4	117	8 1/2	216	2	4 3/4	117	8 3/4	
5/8	0.6250	15.815	2	4 3/4	124	8 3/4	222	2	4 3/4	124	8 3/4	
3/4	0.7500	19.050	2	5 1/2	130	9	229	2	5 1/2	130	9	
7/8	0.8750	22.225	3	6 1/4	156	10 1/4	273	3	6 1/4	156	10 1/4	
1	1.0000	25.400	3	6 3/4	162	11	279	3	6 3/4	162	11	
1 1/16	1.0625	26.988	3	6 3/4	168	11 1/4	286	3	6 3/4	168	11 1/4	
1 1/8	1.1250	28.575	4	7 1/4	181	12 1/4	324	4	7 1/4	181	12 1/4	
1 1/4	1.1875	30.162	4	7 1/2	187	13	330	4	7 1/2	187	13	
1 1/2	1.2500	31.750	4	7 3/4	190	13 1/2	343	4	7 3/4	190	13 1/2	
1 3/8	1.3125	33.338	...	...	...	...	...	4	8 1/4	219	14 1/4	
1 1/2	1.3750	34.925	...	...	...	...	...	4	8 3/4	225	14 1/2	

Drill Diameter, D			Three-Flute Drills				Four-Flute Drills					
Equivalent			Morse Taper No.	Flute Length		Overall Length		Morse Taper No.	Flute Length		Overall Length	
Inch	Deci. Inch	mm		F	L	F	L		F	L	F	L
Inch	Deci. Inch	mm	A	Inch	mm	Inch	mm	A	Inch	mm	Inch	mm
1 3/32	1.4963	35.717	...	...	...	...	...	4	9	229	14 3/4	371
1 1/16	1.4375	36.512	...	...	...	...	...	4	9 1/4	232	14 3/4	375
1 3/32	1.4688	37.306	...	...	...	...	...	4	9 1/2	235	14 3/4	378
1 1/8	1.5000	38.100	...	...	...	...	...	4	9 3/4	238	15	381
1 3/16	1.5312	38.892	...	...	...	...	...	5	9 3/4	238	16 1/4	416
1 1/4	1.3675	39.688	...	...	...	...	...	5	9 3/8	244	16 1/2	422
1 1/8	1.3938	40.483	...	...	...	...	...	5	9 3/8	251	16 3/4	429
1 1/8	1.6250	41.275	...	...	...	...	...	5	10	254	17	432
1 1/8	1.6562	42.067	...	...	...	...	...	5	10 1/8	257	17 1/4	435
1 1/8	1.6875	42.862	...	...	...	...	...	5	10 1/4	257	17 1/4	435
1 1/8	1.7188	43.658	...	...	...	...	...	5	10 1/4	257	17 1/4	435
1 1/2	1.7500	44.450	...	...	...	...	...	5	10 3/4	257	17 3/4	435
1 1/8	1.7812	45.244	...	...	...	...	...	5	10 3/4	257	17 3/4	435
1 1/8	1.8125	46.038	...	...	...	...	...	5	10 3/4	257	17 3/4	435
1 1/8	1.8438	46.833	...	...	...	...	...	5	10 3/4	257	17 3/4	435
1 1/8	1.8750	47.625	...	...	...	...	...	5	10 3/4	264	17 3/4	441
1 1/8	1.9062	48.417	...	...	...	...	...	5	10 3/4	264	17 3/4	441
1 1/8	1.9375	49.212	...	...	...	...	...	5	10 3/4	264	17 3/4	441
1 1/8	1.9688	50.008	...	...	...	...	...	5	10 3/4	264	17 3/4	441
2	2.0000	50.800	...	...	...	...	...	5	10 3/4	264	17 3/4	441
2 1/4	2.1250	53.975	...	...	...	...	...	5	10 3/4	260	17 3/4	441
2 1/4	2.2500	57.150	...	...	...	...	...	5	10 3/4	257	17 3/4	441
2 1/4	2.3750	60.325	...	...	...	...	...	5	10 3/4	257	17 3/4	441
2 1/2	2.5000	63.500	...	...	...	...	...	5	11 1/4	286	18 1/4	476

British Standard Combined Drills and Countersinks (Center Drills).—BS 328: Part 2: 1972 (1990) provides dimensions of combined drills and countersinks for center holes. Three types of drill and countersink combinations are shown in this standard but are not given here. These three types will produce center holes without protecting chamfers, with protecting chamfers, and with protecting chamfers of radius form.

American National Standard Drill Drivers — Split-Sleeve, Collet Type  
ANSI B94.35-1972 (R1995)

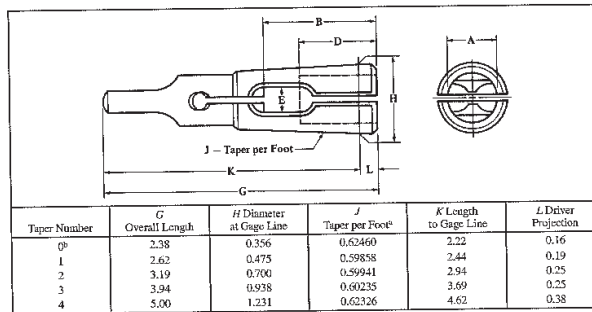

<sup>a</sup>Taper rate in accordance with ANSI/ASME B5.10-1994, Machine Tapers.  
<sup>b</sup>Size 0 is not an American National Standard but is included here to meet special needs.  
All dimensions are in inches.

**Table 14. ANSI Three- and Four-Flute Straight Shank Core Drills — Fractional Sizes Only ANS/ASME B94.11M-1993**

Drill Diameter 11/32" (8.733 mm) and Smaller

Drill Diameter 3/8" (9.525 mm) and Larger

Nominal Shank Size is same as Nominal Drill Size

Drill Diameter, D		Three-Flute Drills				Four-Flute Drills				
Equivalent		Flute Length		Overall Length		Flute Length		Overall Length		
		F		L		F		L		
Tech	Deci. Inch	mm	Inch	mm	Inch	mm	Inch	mm	Inch	mm
1/4	0.2500	6.350	3 1/4	95	6 1/4	156	...	...	...	...
5/16	0.3125	7.142	3 3/4	98	6 1/2	159	...	...	...	...
3/8	0.3750	9.525	4	102	6 3/4	162	...	...	...	...
7/16	0.4375	11.112	4 1/4	105	6 1/2	165	...	...	...	...
1/2	0.5000	12.700	4 1/2	105	6 3/4	171	...	...	...	...
9/16	0.5625	14.288	4 3/4	111	7	178	...	...	...	...
5/8	0.6250	15.875	4 3/4	117	7 1/4	184	...	...	...	...
3/4	0.7500	19.050	4 3/4	121	7 1/2	190	...	...	...	...
7/8	0.8750	22.225	4 3/4	121	7 3/4	197	4 1/4	121	7 3/4	197
1	1.0000	25.400	4 3/4	124	8	203	4 1/4	121	8	203
1 1/16	1.0625	26.988	4 3/4	124	8 1/4	210	4 1/4	124	8 1/4	210
1 1/8	1.1250	28.575	4 3/4	124	8 1/2	222	4 1/4	124	8 1/4	222
1 1/4	1.1875	30.162	4 3/4	124	8 3/4	222	4 1/4	124	8 1/4	222
1 3/8	1.2500	31.750	5 1/4	130	9	229	5 1/4	130	9	229
1 1/2	1.3125	33.337	5 1/4	137	9 1/4	235	5 1/4	137	9 1/4	235
1 5/8	1.3750	34.925	5 3/4	143	9 1/2	241	5 1/4	143	9 1/4	241
1 3/4	1.4375	36.512	5 3/4	149	9 3/4	248	5 1/4	149	9 1/4	248
1 7/8	1.5000	38.100	5 3/4	149	9 3/4	248	6	152	9 1/4	251
2	1.5625	39.687	5 3/4	155	10	254	6 1/4	156	10	254
2 1/16	1.6250	41.275	5 3/4	155	10	254	6 1/4	156	10	254
2 1/8	1.6875	42.862	5 3/4	155	10	254	6 1/4	156	10	254
2 1/4	1.7500	44.450	5 3/4	155	10	254	6 1/4	156	10	254
2 3/8	1.8125	46.037	5 3/4	155	10	254	6 1/4	156	10	254
2 1/2	1.8750	47.625	5 3/4	155	10	254	6 1/4	156	10	254
2 5/8	1.9375	49.212	5 3/4	155	10	254	6 1/4	156	10 1/4	273
2 3/4	2.0000	50.800	5 3/4	155	10	254	6 1/4	156	11	279
2 7/8	2.0625	52.387	5 3/4	155	10	254	6 1/4	156	11	279
3	2.1250	53.975	5 3/4	155	10	254	6 1/4	156	11 1/4	283
3 1/16	2.1875	55.562	5 3/4	155	10	254	6 1/4	156	11 1/4	286
3 1/8	2.2500	57.150	5 3/4	155	10	254	6 1/4	156	11 1/2	292
3 1/4	2.3125	58.737	5 3/4	155	10	254	6 1/4	156	11 1/2	298
3 3/8	2.3750	60.325	5 3/4	155	10	254	6 1/4	156	12 1/2	318

**Drill Drivers—Split-Sleeve, Collet Type.**—American National Standard ANSIB94.35-1972 (R1995) covers split-sleeve, collet-type drivers for driving straight shank drills, reamers, and similar tools, without tangs from 0.0390-inch through 0.1220-inch diameter, and with tangs from 0.1250-inch through 0.7500-inch diameter, including metric sizes.

For sizes 0.0390 through 0.0595 inch, the standard taper number is 1 and the optional taper number is 0. For sizes 0.0610 through 0.1875 inch, the standard taper number is 1, first optional taper number is 0, and second optional taper number is 2. For sizes 0.1890 through 0.2520 inch, the standard taper number is 1, first optional taper number is 2, and second optional taper number is 0. For sizes 0.2570 through 0.3750 inch, the standard taper number is 1 and the optional taper number is 2. For sizes 0.3860 through 0.5625 inch, the standard taper number is 2 and the optional taper number is 3. For sizes 0.5781 through 0.7500 inch, the standard taper number is 3 and the optional taper number is 4.

The depth  $B$  that the drill enters the driver is 0.44 inch for sizes 0.0390 through 0.0781 inch; 0.50 inch for sizes 0.0785 through 0.0938 inch; 0.56 inch for sizes 0.0960 through 0.1094 inch; 0.62 inch for sizes 0.1100 through 0.1220 inch; 0.75 inch for sizes 0.1250 through 0.1875 inch; 0.88 inch for sizes 0.1890 through 0.2500 inch; 1.00 inch for sizes 0.2520 through 0.3125 inch; 1.12 inches for sizes 0.3160 through 0.3750 inch; 1.25 inches for sizes 0.3860 through 0.4688 inch; 1.31 inches for sizes 0.4844 through 0.5625 inch; 1.47 inches for sizes 0.5781 through 0.6562 inch; and 1.62 inches for sizes 0.6719 through 0.7500 inch.

**British Standard Metric Twist Drills.**—BS 328: Part I: 1959 (incorporating amendments issued March 1960 and March 1964) covers twist drills made to inch and metric dimensions that are intended for general engineering purposes. ISO recommendations are taken into account. The accompanying tables give the standard metric sizes of Morse taper shank twist drills and core drills, parallel shank jobbing and long series drills, and stub drills.

All drills are right-hand cutting unless otherwise specified, and normal, slow, or quick helix angles may be provided. A "back-taper" is ground on the diameter from point to shank to provide longitudinal clearance. Core drills may have three or four flutes, and are intended for opening up cast holes or enlarging machined holes, for example. The parallel shank jobber, and long series drills, and stub drills are made without driving tenons.

Morse taper shank drills with oversize dimensions are also listed, and Table 15 shows metric drill sizes superseding gage and letter size drills, which are now obsolete in Britain. To meet special requirements, the Standard lists nonstandard sizes for the various types of drills.

The limits of tolerance on cutting diameters, as measured across the lands at the outer corners of a drill, shall be h8, in accordance with BS 1916, Limits and Fits for Engineering (Part I, Limits and Tolerances), and Table 3 shows the values common to the different types of drills mentioned before.

The drills shall be permanently and legibly marked whenever possible, preferably by rolling, showing the size, and the manufacturer's name or trademark. If they are made from high-speed steel, they shall be marked with the letters H.S. where practicable.

*Drill Elements:* The following definitions of drill elements are given.

*Axis:* The longitudinal center line.

*Body:* That portion of the drill extending from the extreme cutting end to the commencement of the shank.

*Shank:* That portion of the drill by which it is held and driven.

*Flutes:* The grooves in the body of the drill that provide lips and permit the removal of chips and allow cutting fluid to reach the lips.

*Web (Core):* The central portion of the drill situated between the roots of the flutes and extending from the point end toward the shank; the point end of the web or core forms the chisel edge.

*Lands:* The cylindrical-ground surfaces on the leading edges of the drill flutes. The width of the land is measured at right angles to the flute helix.

*Body Clearance:* The portion of the body surface that is reduced in diameter to provide diametral clearance.

*Heel:* The edge formed by the intersection of the flute surface and the body clearance.

*Point:* The sharpened end of the drill, consisting of all that part of the drill that is shaped to produce lips, faces, flanks, and chisel edge.

*Face:* That portion of the flute surface adjacent to the lip on which the chip impinges as it is cut from the work.

*Flank:* The surface on a drill point that extends behind the lip to the following flute.

*Lip (Cutting Edge):* The edge formed by the intersection of the flank and face.

*Relative Lip Height:* The relative position of the lips measured at the outer corners in a direction parallel to the drill axis.

*Outer Corner:* The corner formed by the intersection of the lip and the leading edge of the land.

*Chisel Edge:* The edge formed by the intersection of the flanks.

*Chisel Edge Corner:* The corner formed by the intersection of a lip and the chisel edge.

**Table 15. British Standard Drills — Metric Sizes Superseding Gauge and Letter Sizes BS 328; Part 1: 1959 Appendix B**

Obsolete Drill Size	Recommended Metric Size (mm)	Obsolete Drill Size	Recommended Metric Size (mm)	Obsolete Drill Size	Recommended Metric Size (mm)	Obsolete Drill Size	Recommended Metric Size (mm)	Obsolete Drill Size	Recommended Metric Size (mm)
80	0.35	38	1.05	36	2.70	14	4.60	I	6.90
79	0.38	57	1.10			13	4.70	J	7.00
78	0.40	56	$\frac{1}{16}$ in.	35	2.80	12	4.80		
77	0.45			34	2.80	11	4.90		
76	0.50			33	2.85			K	$\frac{1}{16}$ in.
		55	1.30	33	2.85			L	7.40
		54	1.40	32	2.95	10	4.90	M	7.50
75	0.52	53	1.50	31	3.00	9	5.00	N	7.70
74	0.58	52	1.60			8	5.10	O	8.00
73	0.60	51	1.70	30	3.30	7	5.10		
72	0.65			29	3.50	6	5.20		
71	0.65			28	$\frac{1}{8}$ in.				
		50	1.80	27	3.70			P	8.20
		49	1.85	26	3.70	5	5.20	Q	8.40
70	0.70	48	1.95			4	5.30	R	8.60
69	0.75	47	2.00	25	3.80	3	5.40	S	8.80
68	$\frac{1}{16}$ in.	46	2.05	24	3.90	2	5.60	T	9.10
67	0.82			23	3.90	1	5.80		
66	0.85	45	2.10	22	4.00			U	9.30
		44	2.20	21	4.00	A	$\frac{1}{16}$ in.	V	$\frac{1}{16}$ in.
65	0.90	43	2.25			B	6.00	W	9.80
64	0.92	42	$\frac{3}{16}$ in.	20	4.10	C	6.10	X	10.10
63	0.98	41	2.45	19	4.20	D	6.20	Y	10.30
62	0.98			18	4.30	E	$\frac{1}{4}$ in.	Z	10.50
61	1.00	40	2.50	17	4.40				
		39	2.55	16	4.50	F	6.50	...	...
60	1.00	38	2.60			G	6.60	...	...
59	1.05	37	2.65	15	4.60	H	$\frac{3}{16}$ in.	...	...

Gauge and letter size drills are now obsolete in the United Kingdom and should not be used in the production of new designs. The table is given to assist users in changing over to the recommended standard sizes.

Table 1. British Standard Morse Taper Shank Twist Drills and Core Drills — Standard Metric Sizes BS 328: Part 1: 1959

Diameter	Flute Length	Overall Length	Diameter	Flute Length	Overall Length	Diameter	Flute Length	Overall Length
3.00	33	114	16.25			29.50		
3.20	36	117	16.50	125	223	29.75	175	296
3.50	39	120	16.75			30.00		
3.80			17.00			30.25		
4.00	43	123	17.25	130	228	30.50	180	301
4.20			17.50			30.75		
4.50	47	128	17.75			31.00		
4.80			18.00			31.25		
5.00	52	133	18.25	135	233	31.50	185	306
5.20			18.50			31.75		
5.50			18.75			32.00		
5.80	57	138	19.00	140	238	32.50	185	334
6.00			19.25			33.00		
6.20			19.50			33.50		
6.50	63	144	19.75	145	243	34.00	190	339
6.80			20.00			34.50		
7.00	69	150	20.25	150	248	35.00	195	344
7.20			20.50			36.00		
7.50			20.75			36.50		
7.80			21.00			37.00		
8.00	75	156	21.25	155	253	37.50	200	349
8.20			21.50			38.00		
8.50			21.75			38.50		
8.80			22.00			39.00		
9.00	81	162	22.25	155	253	39.50	205	354
9.20			22.50			40.00		
9.50			22.75			40.50		
9.80			23.00			41.00		
10.00	87	168	23.25	155	276	41.50	210	359
10.20			23.50			42.00		
10.50			23.75			42.50		
10.80			24.00	160	281	43.00	215	364
11.00	94	175	24.25			43.50		
11.20			24.50			44.00		
11.50			24.75			44.50		
11.80			25.00			45.00		
12.00			25.25	165	286	45.50	220	369
12.20	101	182	25.50			46.00		
12.50			25.75			46.50		
12.80			26.00			47.00		
13.00			26.25			47.50		
13.20			26.50			48.00		
13.50			26.75	170	291	48.50	225	374
13.80	108	189	27.00			49.00		
14.00			27.25			49.50		
14.25			27.50			50.00		
14.50	114	212	27.75	175	296	50.50	230	417
14.75			28.00			51.00		
15.00			28.25			52.00		
15.25			28.50			53.00		
15.50			28.75			54.00		
15.75	120	218	29.00			55.00		
16.00			29.25					

**Table 1. British Standard Morse Taper Shank Twist Drills and Core Drills — Standard Metric Sizes BS 328: Part 1: 1959**

Diameter	Flute Length	Overall Length	Diameter	Flute Length	Overall Length	Diameter	Flute Length	Overall Length
56.00	230	417	71.00	250	437	86.00		
57.00			72.00			87.00		
58.00	235	422	73.00	255	442	88.00	270	524
59.00			74.00			89.00		
60.00			75.00			90.00		
61.00	240	427	76.00	260	477	91.00		
62.00						92.00		
63.00			77.00			93.00	275	529
64.00			78.00	260	514	94.00		
65.00	245	432	79.00			95.00		
66.00			80.00					
67.00			81.00			96.00		
68.00			82.00			97.00		
69.00	250	437	83.00	265	519	98.00	280	534
70.00			84.00			99.00		
			85.00			100.00		

All dimensions are in millimeters. Tolerances on diameters are given in the table below.

Table 2, shows twist drills that may be supplied with the shank and length oversize, but they should be regarded as non-preferred.

The Morse taper shanks of these twist and core drills are as follows: 3.00 to 14.00 mm diameter, M.T. No. 1; 14.25 to 23.00 mm diameter, M.T. No. 2; 23.25 to 31.50 mm diameter, M.T. No. 3; 31.75 to 50.50 mm diameter, M.T. No. 4; 51.00 to 76.00 mm diameter, M.T. No. 5; 77.00 to 100.00 mm diameter, M.T. No. 6.

**Table 2. British Standard Morse Taper Shank Twist Drills — Metric Oversize Shank and Length Series BS 328: Part 1: 1959**

Dia. Range	Overall Length	M. T. No.	Dia. Range	Overall Length	M. T. No.	Dia. Range	Overall Length	M. T. No.
12.00 to 13.30	199	2	22.50 to 23.00	276	3	45.50 to 47.50	402	5
13.50 to 14.00	206	2	26.75 to 28.00	319	4	48.00 to 50.00	407	5
18.25 to 19.00	256	3	29.00 to 30.00	324	4	50.50	412	5
19.25 to 20.00	251	3	30.25 to 31.50	329	4	64.00 to 67.00	499	6
20.25 to 21.00	266	3	40.50 to 42.50	392	5	68.00 to 71.00	504	6
21.25 to 22.25	271	3	43.00 to 45.00	397	5	72.00 to 75.00	509	6

Diameters and lengths are given in millimeters. For the individual sizes within the diameter ranges given, see Table 1.

This series of drills should be regarded as non-preferred.

**Table 3. British Standard Limits of Tolerance on Diameter for Twist Drills and Core Drills — Metric Series BS 328: Part 1: 1959**

Drill Size (Diameter measured across lands at outer corners)	Tolerance (h8)
0 to 1 inclusive	Plus 0.000 to Minus 0.014
Over 1 to 3 inclusive	Plus 0.000 to Minus 0.014
Over 3 to 6 inclusive	Plus 0.000 to Minus 0.018
Over 6 to 10 inclusive	Plus 0.000 to Minus 0.022
Over 10 to 18 inclusive	Plus 0.000 to Minus 0.027
Over 18 to 30 inclusive	Plus 0.000 to Minus 0.033
Over 30 to 50 inclusive	Plus 0.000 to Minus 0.039
Over 50 to 80 inclusive	Plus 0.000 to Minus 0.046
Over 80 to 120 inclusive	Plus 0.000 to Minus 0.054

All dimensions are given in millimeters.



**Table 4. British Standard Parallel Shank Jobber Series Twist Drills — Standard Metric Sizes BS 328: Part 1: 1959**

Diameter	Flute Length	Overall Length	Diameter	Flute Length	Overall Length	Diameter	Flute Length	Overall Length	Diameter	Flute Length	Overall Length
0.20	2.5	19	1.75	22	46	5.40	57	93	10.20	87	133
0.22			1.80			5.50			10.30		
0.25			1.85			5.60			10.40		
0.28	3.0	19	1.90	24	49	5.70	57	93	10.50	87	133
0.30			1.95			5.80			10.60		
0.32	4	19	2.00	27	53	5.90	63	101	10.70	94	142
0.35			2.05			6.00			10.80		
0.38			2.10			6.10			10.90		
0.40	5	20	2.15	30	57	6.20	69	109	11.00	101	151
0.42			2.20			6.30			11.10		
0.45			2.25			6.40			11.20		
0.48			2.30			6.50			11.30		
			2.35			6.60			11.40		
0.50	6	22	2.40	33	61	6.70	75	117	11.50	101	151
0.52			2.45			6.80			11.60		
0.55			2.50			6.90			11.70		
0.58	7	24	2.55	36	65	7.00	81	125	11.80	108	160
0.60			2.60			7.10			11.90		
0.62	8	26	2.65	39	70	7.20	81	125	12.00	114	169
0.65			2.70			7.30			12.10		
0.68			2.75			7.40			12.20		
0.70	9	28	2.80	43	75	7.50	81	125	12.30	114	169
0.72			2.85			7.60			12.40		
0.75	10	30	2.90	47	80	7.70	87	133	12.50	120	178
0.78			2.95			7.80			12.60		
0.80			3.00			7.90			12.70		
0.82	11	32	3.10	49	86	8.00	87	133	12.80	120	178
0.85			3.20			8.10			12.90		
0.88	12	34	3.30	52	86	8.20	87	133	13.00	120	178
0.90			3.40			8.30			13.10		
0.92			3.50			8.40			13.20		
0.95	14	36	3.60	57	93	8.50	87	133	13.30	120	178
0.98			3.70			8.60			13.40		
1.00	16	38	3.80	61	99	8.70	87	133	13.50	120	178
1.05			3.90			8.80			13.60		
1.10			4.00			8.90			13.70		
1.15	18	40	4.10	65	105	9.00	87	133	13.80	120	178
1.20			4.20			9.10			13.90		
1.25	20	43	4.30	69	111	9.20	87	133	14.00	120	178
1.30			4.40			9.30			14.25		
1.35			4.50			9.40			14.50		
1.40	18	40	4.60	73	117	9.50	87	133	14.75	120	178
1.45			4.70			9.60			15.00		
1.50	20	43	4.80	77	123	9.70	87	133	15.25	120	178
1.55			4.90			9.80			15.50		
1.60			5.00			9.90			15.75		
1.65	22	46	5.10	81	129	10.00	87	133	16.00	120	178
1.70			5.20			10.10					
			5.30								

All dimensions are in millimeters. Tolerances on diameters are given in Table 3.

**Table 5. British Standard Parallel Shank Long Series Twist Drills — Standard Metric Sizes BS 328: Part 1: 1959**

Diameter	Flute Length	Overall Length	Diameter	Flute Length	Overall Length	Diameter	Flute Length	Overall Length
2.00	56	85	6.80	102	156	12.70	134	205
2.05			6.90			12.80		
2.10			7.00			12.90		
2.15	59	90	7.10			13.00		
2.20			7.20			13.10		
2.25			7.30			13.20		
2.30			7.40			13.30		
2.35			7.50			13.40		
2.40	62	95	7.60	109	165	13.50	140	214
2.45			7.70			13.60		
2.50			7.80			13.70		
2.55			7.90			13.80		
2.60			8.00			13.90		
2.65			8.10			14.00		
2.70	66	100	8.20			14.25	144	220
2.75			8.30			14.50		
2.80			8.40			14.75		
2.85			8.50			15.00		
2.90			8.60			15.25		
2.95	69	106	8.70	115	175	15.50	149	227
3.00			8.80			15.75		
3.10			8.90			16.00		
3.20			9.00			16.25		
3.30			9.10			16.50		
3.40	73	112	9.20			16.75	154	235
3.50			9.30			17.00		
3.60			9.40			17.25		
3.70			9.50			17.50		
3.80	78	119	9.60	121	184	17.75	158	241
3.90			9.70			18.00		
4.00			9.80			18.25		
4.10			9.90			18.50		
4.20			10.00			18.75		
4.30	82	126	10.10			19.00	162	247
4.40			10.20			19.25		
4.50			10.30			19.50		
4.60			10.40			19.75		
4.70			10.50			20.00		
4.80	87	132	10.60	128	195	20.25	171	261
4.90			10.70			20.50		
5.00			10.80			20.75		
5.10			10.90			21.00		
5.20			11.00			21.25		
5.30			11.10			21.50		
5.40	91	139	11.20			21.75	176	268
5.50			11.30			22.00		
5.60			11.40			22.25		
5.70			11.50			22.50		
5.80			11.60			22.75		
5.90	97	148	11.70	134	205	23.00	180	275
6.00			11.80			23.25		
6.10			11.90			23.50		
6.20			12.00			23.75		
6.30			12.10			24.00		
6.40	12.20	24.25						
6.50	12.30	24.50						
6.60	12.40	24.75						
6.70	12.50	25.00						

All dimensions are in millimeters. Tolerances on diameters are given in Table 3.

Table 6. British Standard Stub Drills — Metric Sizes BS 328: Part 1: 1959

Diameter	Flute Length	Overall Length	Diameter	Flute Length	Overall Length	Diameter	Flute Length	Overall Length	Diameter	Flute Length	Overall Length
0.50	3	20	5.00	26	62	9.50	40	84	14.00	54	107
0.80	5	24	5.20			9.80			14.50		
1.00	6	26	5.50			10.00	43	89	15.00	56	111
1.20	8	30	5.80	28	66	10.20			15.50		
1.50	9	32	6.00			10.50			16.00	58	115
1.80	11	36									
2.00	12	38	6.20		70	10.80			16.50	60	119
2.20	13	40	6.50	31		11.00			17.00		
2.50	14	43	6.80			11.20	47	95	17.50	62	123
2.80	16	46	7.00	34	74	11.50			18.00		
3.00	18	49	7.20			11.80			18.50	64	127
3.20	18	49	7.50			12.00			19.00		
3.50	20	52	7.80			12.20			19.50	66	131
			8.00	37	79	12.50			20.00		
3.80			8.20			12.80	51	102	21.00	68	136
4.00	22	55	8.50			13.00			22.00	70	141
4.20			8.80			13.20			23.00	72	146
4.50	24	58	9.00	40	84	13.50			24.00	75	151
4.80	26	62	9.20			13.80	54	107	25.00		

All dimensions are given in millimeters. Tolerances on diameters are given in Table 3.

**Steels for Twist Drills.**—Twist drill steels need good toughness, abrasion resistance, and ability to resist softening due to heat generated by cutting. The amount of heat generated indicates the type of steel that should be used.

*Carbon Tool Steel:* may be used where little heat is generated during drilling.

*High-Speed Steel:* is preferred because of its combination of red hardness and wear resistance, which permit higher operating speeds and increased productivity. Optimum properties can be obtained by selection of alloy analysis and heat treatment.

*Cobalt High-Speed Steel:* alloys have higher red hardness than standard high-speed steels, permitting drilling of materials such as heat-resistant alloys and materials with hardness greater than Rockwell 38 C. These high-speed drills can withstand cutting speeds beyond the range of conventional high-speed-steel drills and have superior resistance to abrasion but are not equal to tungsten-carbide tipped tools.

**Accuracy of Drilled Holes.**—Normally the diameter of drilled holes is not given a tolerance; the size of the hole is expected to be as close to the drill size as can be obtained.

The accuracy of holes drilled with a two-fluted twist drill is influenced by many factors, which include: the accuracy of the drill point; the size of the drill; length and shape of the chisel edge; whether or not a bushing is used to guide the drill; the work material; length of the drill; runout of the spindle and the chuck; rigidity of the machine tool, workpiece, and the setup; and also the cutting fluid used, if any.

The diameter of the drilled holes will be oversize in most materials. The table following provides the results of tests reported by The United States Cutting Tool Institute in which the diameters of over 2800 holes drilled in steel and cast iron were measured. The values in this table indicate what might be expected under average shop conditions; however, when the drill point is accurately ground and the other machining conditions are correct, the resulting hole size is more likely to be between the mean and average minimum values given in this table. If the drill is ground and used incorrectly, holes that are even larger than the average maximum values can result.

## Oversize Diameters in Drilling

Drill Dia., Inch.	Amount Oversize, Inch			Drill Dia., Inch.	Amount Oversize, Inch		
	Average Max.	Mean	Average Min.		Average Max.	Mean	Average Min.
$\frac{1}{16}$	0.002	0.0015	0.001	$\frac{1}{2}$	0.008	0.005	0.003
$\frac{1}{8}$	0.0045	0.003	0.001	$\frac{3}{4}$	0.008	0.005	0.003
$\frac{1}{4}$	0.0065	0.004	0.0025	1	0.009	0.007	0.004

Courtesy of The United States Cutting Tool Institute

Some conditions will cause the drilled hole to be undersize. For example, holes drilled in light metals and in other materials having a high coefficient of thermal expansion such as plastics, may contract to a size that is smaller than the diameter of the drill as the material surrounding the hole is cooled after having been heated by the drilling. The elastic action of the material surrounding the hole may also cause the drilled hole to be undersize when drilling high strength materials with a drill that is dull at its outer corner.

The accuracy of the drill point has a great effect on the accuracy of the drilled hole. An inaccurately ground twist drill will produce holes that are excessively over-size. The drill point must be symmetrical; i.e., the point angles must be equal, as well as the lip lengths and the axial height of the lips. Any alterations to the lips or to the chisel edge, such as thinning the web, must be done carefully to preserve the symmetry of the drill point. Adequate relief should be provided behind the chisel edge to prevent heel drag. On conventionally ground drill points this relief can be estimated by the chisel edge angle.

When drilling a hole, as the drill point starts to enter the workpiece, the drill will be unstable and will tend to wander. Then as the body of the drill enters the hole the drill will tend to stabilize. The result of this action is a tendency to drill a bellmouth shape in the hole at the entrance and perhaps beyond. Factors contributing to bellmouthing are: an unsymmetrically ground drill point; a large chisel edge length; inadequate relief behind the chisel edge; runout of the spindle and the chuck; using a slender drill that will bend easily; and lack of rigidity of the machine tool, workpiece, or the setup. Correcting these conditions as required will reduce the tendency for bellmouthing to occur and improve the accuracy of the hole diameter and its straightness. Starting the hole with a short stiff drill, such as a center drill, will quickly stabilize the drill that follows and reduce or eliminate bellmouthing; this procedure should always be used when drilling in a lathe, where the work is rotating. Bellmouthing can also be eliminated almost entirely and the accuracy of the hole improved by using a close fitting drill jig bushing placed close to the workpiece. Although specific recommendations cannot be made, many cutting fluids will help to increase the accuracy of the diameters of drilled holes. Double margin twist drills, available in the smaller sizes, will drill a more accurate hole than conventional twist drills having only a single margin at the leading edge of the land. The second land, located on the trailing edge of each land, provides greater stability in the drill bushing and in the hole. These drills are especially useful in drilling intersecting off-center holes. Single and double margin step drills, also available in the smaller sizes, will produce very accurate drilled holes, which are usually less than 0.002 inch larger than the drill size.

**Counterboring.**—Counterboring (called spot-facing if the depth is shallow) is the enlargement of a previously formed hole. Counterbores for screw holes are generally made in sets. Each set contains three counterbores: one with the body of the size of the screw head and the pilot the size of the hole to admit the body of the screw; one with the body the size of the head of the screw and the pilot the size of the tap drill; and the third with the body the size of the body of the screw and the pilot the size of the tap drill. Counterbores are usually provided with helical flutes to provide positive effective rake on the cutting edges. The four flutes are so positioned that the end teeth cut ahead of center to provide a shearing action and eliminate chatter in the cut. Three designs are most common: solid, two-piece, and three-piece. Solid designs have the body, cutter, and pilot all in one piece. Two-piece designs have an integral shank and counterbore cutter, with an interchangeable pilot, and provide true concentricity of the cutter diameter with the shank, but allowing use of various

pilot diameters. Three-piece counterbores have separate holder, counterbore cutter, and pilot, so that a holder will take any size of counterbore cutter. Each counterbore cutter, in turn, can be fitted with any suitable size diameter of pilot. Counterbores for brass are fluted straight.

Counterbores with Interchangeable Cutters and Guides

No. of Holder	No. of Morse Taper Shank	Range of Cutter Diameters, A	Range of Pilot Diameters, B	Total Length, C	Length of Cutter Body, D	Length of Pilot, E	Dia. of Shank, F
1	1 or 2	$\frac{1}{2}$ - $1\frac{1}{16}$	$\frac{1}{2}$ - $2\frac{1}{4}$	$7\frac{1}{4}$	1	$\frac{5}{8}$	$\frac{3}{4}$
2	2 or 3	$1\frac{1}{2}$ - $1\frac{15}{16}$	$1\frac{1}{8}$ - $1\frac{1}{4}$	$9\frac{1}{2}$	$1\frac{1}{2}$	$\frac{7}{8}$	$1\frac{1}{8}$
3	3 or 4	$1\frac{3}{8}$ - $2\frac{1}{16}$	$\frac{7}{8}$ - $1\frac{3}{8}$	$12\frac{1}{2}$	$1\frac{3}{4}$	$1\frac{1}{2}$	$1\frac{3}{8}$
4	4 or 5	$2\frac{1}{2}$ - $3\frac{1}{2}$	1- $2\frac{1}{2}$	15	$2\frac{1}{2}$	$1\frac{3}{8}$	$2\frac{1}{4}$

Solid Counterbores with Integral Pilot

Counterbore Diameters	Pilot Diameters			Straight Shank Diameter	Overall Length	
	Nominal	+ $\frac{1}{64}$	+ $\frac{1}{32}$		Short	Long
$\frac{1}{2}$	$\frac{1}{4}$	$\frac{7}{64}$	$\frac{1}{8}$	$\frac{3}{8}$	$3\frac{1}{2}$	$5\frac{1}{2}$
$\frac{5}{8}$	$\frac{3}{8}$	$\frac{2}{64}$	$\frac{1}{16}$	$\frac{1}{2}$	$3\frac{1}{2}$	$5\frac{1}{2}$
$\frac{7}{8}$	$\frac{5}{8}$	$\frac{3}{64}$	$\frac{1}{8}$	$\frac{1}{2}$	4	6
$1\frac{1}{8}$	$\frac{7}{8}$	$\frac{2}{64}$	$\frac{1}{8}$	$\frac{1}{2}$	4	6
$1\frac{1}{4}$	$1\frac{1}{8}$	$\frac{3}{64}$	$\frac{1}{8}$	$\frac{1}{2}$	5	7
0.110	0.060	0.076	...	$\frac{3}{16}$	$2\frac{1}{2}$	...
0.133	0.073	0.089	...	$\frac{1}{4}$	$2\frac{1}{2}$	...
0.155	0.086	0.102	...	$\frac{5}{16}$	$2\frac{1}{2}$	...
0.176	0.099	0.115	...	$\frac{11}{64}$	$2\frac{1}{2}$	...
0.198	0.112	0.128	...	$\frac{3}{8}$	$2\frac{1}{2}$	...
0.220	0.125	0.141	...	$\frac{7}{16}$	$2\frac{1}{2}$	...
0.241	0.138	0.154	...	$\frac{1}{2}$	$2\frac{1}{2}$	...
0.285	0.164	0.180	...	$\frac{1}{2}$	$2\frac{1}{2}$	...
0.327	0.190	0.206	...	$\frac{5}{16}$	$2\frac{1}{2}$	...
0.372	0.216	0.232	...	$\frac{3}{8}$	$2\frac{1}{2}$	...

All dimensions are in inches.

Small counterbores are often made with three flutes, but should then have the size plainly stamped on them before fluting, as they cannot afterwards be conveniently measured. The flutes should be deep enough to come below the surface of the pilot. The counterbore should be relieved on the end of the body only, and not on the cylindrical surface. To facilitate the relieving process, a small neck is turned between the guide and the body for clearance. The amount of clearance on the cutting edges is, for general work, from 4 to 5 degrees. The accompanying table gives dimensions for straight shank counterbores.

**Three Piece Counterbores.**—Data shown for the first two styles of counterbores are for straight shank designs. These tools are also available with taper shanks in most sizes. Sizes of taper shanks for cutter diameters of  $\frac{1}{4}$  to  $\frac{5}{16}$  in. are No. 1, for  $\frac{19}{32}$  to  $\frac{7}{8}$  in., No. 2; for  $\frac{1}{8}$  to  $1\frac{1}{8}$  in., No. 3; for  $1\frac{1}{2}$  to 2 in., No. 4; and for  $2\frac{1}{8}$  to  $2\frac{1}{2}$  in., No. 5.

STANDARD CARBIDE BORING TOOLS

859

**Table 1. American National Standard Sintered Carbide Boring Tools—Style Designations ANSI B212.1-1984 (R1997)**

Side Cutting Edge Angle $E$ Degrees	Designation	Boring Tool Styles			
		Solid Square (SS)	Tipped Square (TS)	Solid Round (SR)	Tipped Round (TR)
0	A		TSA		
10	B		TSB		
30	C	SSC	TSC	SRC	TRC
40	D		TSD		
45	E	SSE	TSE	SRE	TRE
55	F		TSF		
90 (0° Rake)	G				TRG
90 (10° Rake)	H				TRH

**Table 2. American National Standard Solid Carbide Square Boring Tools—Style SSC for 60° Boring Bar and Style SSE for 45° Boring Bar ANSI B212.1-1984 (R1997)**

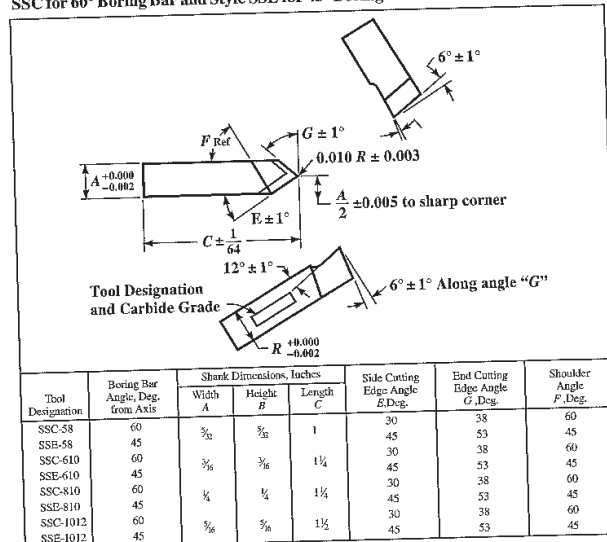

**Counterbore Sizes for Hex-head Bolts and Nuts.**—Table 2, page 1511, shows the maximum socket wrench dimensions for standard 1/4, 1/2 and 3/4-inch drive socket sets. For a given socket size (nominal size equals the maximum width across the flats of nut or bolt head), the dimension  $K$  given in the table is the minimum counterbore diameter required to provide socket wrench clearance for access to the bolt or nut.

**Sintered Carbide Boring Tools.**—Industrial experience has shown that the shapes of tools used for boring operations need to be different from those of single-point tools ordinarily used for general applications such as lathe work. Accordingly, Section 5 of American National Standard ANSI B212.1-1984 (R1997) gives standard sizes, styles and

designations for four basic types of sintered carbide boring tools, namely: solid carbide square; carbide-tipped square; solid carbide round; and carbide-tipped round boring tools. In addition to these ready-to-use standard boring tools, solid carbide round and square unsharpened boring tool bits are provided.

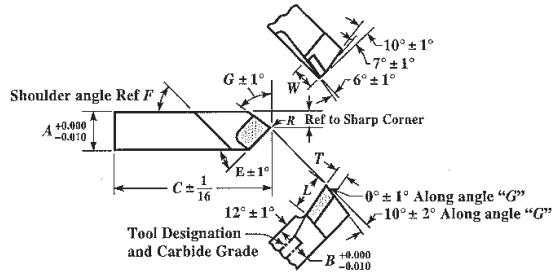

Table 3. American National Standard Carbide-Tipped Square Boring Tools—  
Styles TSA and TSB for 90° Boring Bar, Styles TSC and TSD for 60° Boring Bar, and  
Styles TSE and TSF for 45° Boring Bar ANSI B212.1-1984 (R1997)

Tool Designation	Bar, Bar Angle from Axis, Deg.	Shank Dimensions, Inches				Side-Cut. Edge Angle E, Deg.	End Cut. Edge Angle G, Deg.	Shoulder Angle F, Deg.	Tip No.	Tip Dimensions, Inches		
		A	B	C	R					T	W	L
TSA-5	90	$\frac{3}{16}$	$\frac{3}{16}$	$1\frac{1}{2}$	$\left(\frac{1}{64} \pm 0.005\right)$	0	8	90	2040	$\frac{3}{32}$	$\frac{3}{16}$	$\frac{3}{16}$
TSB-5	90	$\frac{3}{16}$	$\frac{3}{16}$	$1\frac{1}{2}$		10	8	90	2040	$\frac{3}{32}$	$\frac{3}{16}$	$\frac{3}{16}$
TSC-5	60	$\frac{3}{16}$	$\frac{3}{16}$	$1\frac{1}{2}$		30	38	60	2040	$\frac{3}{32}$	$\frac{3}{16}$	$\frac{3}{16}$
TSD-5	60	$\frac{3}{16}$	$\frac{3}{16}$	$1\frac{1}{2}$		40	38	60	2040	$\frac{3}{32}$	$\frac{3}{16}$	$\frac{3}{16}$
TSE-5	45	$\frac{3}{16}$	$\frac{3}{16}$	$1\frac{1}{2}$		45	53	45	2040	$\frac{3}{32}$	$\frac{3}{16}$	$\frac{3}{16}$
TSF-5	45	$\frac{3}{16}$	$\frac{3}{16}$	$1\frac{1}{2}$		55	53	45	2040	$\frac{3}{32}$	$\frac{3}{16}$	$\frac{3}{16}$
TSA-6	90	$\frac{3}{8}$	$\frac{3}{8}$	$1\frac{3}{4}$	$\left(\frac{1}{64} \pm 0.005\right)$	0	8	90	2040	$\frac{3}{32}$	$\frac{3}{16}$	$\frac{3}{16}$
TSB-6	90	$\frac{3}{8}$	$\frac{3}{8}$	$1\frac{3}{4}$		10	8	90	2040	$\frac{3}{32}$	$\frac{3}{16}$	$\frac{3}{16}$
TSC-6	60	$\frac{3}{8}$	$\frac{3}{8}$	$1\frac{3}{4}$		30	38	60	2040	$\frac{3}{32}$	$\frac{3}{16}$	$\frac{3}{16}$
TSD-6	60	$\frac{3}{8}$	$\frac{3}{8}$	$1\frac{3}{4}$		40	38	60	2040	$\frac{3}{32}$	$\frac{3}{16}$	$\frac{3}{16}$
TSE-6	45	$\frac{3}{8}$	$\frac{3}{8}$	$1\frac{3}{4}$		45	53	45	2040	$\frac{3}{32}$	$\frac{3}{16}$	$\frac{3}{16}$
TSF-6	45	$\frac{3}{8}$	$\frac{3}{8}$	$1\frac{3}{4}$		55	53	45	2040	$\frac{3}{32}$	$\frac{3}{16}$	$\frac{3}{16}$

**Table 3. (Continued) American National Standard Carbide-Tipped Square Boring Tools — Styles TSA and TSB for 90° Boring Bar, Styles TSC and TSD for 60° Boring Bar, and Styles TSE and TSF for 45° Boring Bar ANSI B21.1-1984 (R1997)**

Tool Designation	Bor. Bar Angle from Axis, Deg.	Shank Dimensions, Inches				Side Cut. Edge Angle E, Deg.	End Cut. Edge Angle G, Deg.	Shoulder Angle F, Deg.	Tip No.	Tip Dimensions, Inches			
		A	B	C	R					T	W	L	
TSA-7	90	$\frac{3}{16}$	$\frac{3}{16}$	$2\frac{1}{2}$	$\left(\frac{1}{32} \pm 0.010\right)$	0	8	90	2060	$\frac{3}{16}$	$\frac{1}{4}$	$\frac{3}{8}$	
TSB-7	90	$\frac{7}{16}$	$\frac{7}{16}$	$2\frac{1}{2}$		10	8	90	2060	$\frac{3}{16}$	$\frac{1}{4}$	$\frac{3}{8}$	
TSC-7	60	$\frac{3}{16}$	$\frac{3}{16}$	$2\frac{1}{2}$		30	38	60	2060	$\frac{3}{16}$	$\frac{1}{4}$	$\frac{3}{8}$	
TSD-7	60	$\frac{3}{16}$	$\frac{3}{16}$	$2\frac{1}{2}$		40	38	60	2060	$\frac{3}{16}$	$\frac{1}{4}$	$\frac{3}{8}$	
TSE-7	45	$\frac{3}{16}$	$\frac{3}{16}$	$2\frac{1}{2}$		45	53	45	2060	$\frac{3}{16}$	$\frac{1}{4}$	$\frac{3}{8}$	
TSF-7	45	$\frac{3}{16}$	$\frac{3}{16}$	$2\frac{1}{2}$		55	53	45	2060	$\frac{3}{16}$	$\frac{1}{4}$	$\frac{3}{8}$	
TSA-8	90	$\frac{1}{2}$	$\frac{1}{2}$	$2\frac{1}{2}$		$\left(\frac{1}{32} \pm 0.010\right)$	0	8	90	2150	$\frac{1}{8}$	$\frac{5}{16}$	$\frac{7}{16}$
TSB-8	90	$\frac{1}{2}$	$\frac{1}{2}$	$2\frac{1}{2}$			10	8	90	2150	$\frac{1}{8}$	$\frac{5}{16}$	$\frac{7}{16}$
TSC-8	60	$\frac{1}{2}$	$\frac{1}{2}$	$2\frac{1}{2}$	30		38	60	2150	$\frac{1}{8}$	$\frac{5}{16}$	$\frac{7}{16}$	
TSD-8	60	$\frac{1}{2}$	$\frac{1}{2}$	$2\frac{1}{2}$	40		38	60	2150	$\frac{1}{8}$	$\frac{5}{16}$	$\frac{7}{16}$	
TSE-8	45	$\frac{1}{2}$	$\frac{1}{2}$	$2\frac{1}{2}$	45		53	45	2150	$\frac{1}{8}$	$\frac{5}{16}$	$\frac{7}{16}$	
TSF-8	45	$\frac{1}{2}$	$\frac{1}{2}$	$2\frac{1}{2}$	55		53	45	2150	$\frac{1}{8}$	$\frac{5}{16}$	$\frac{7}{16}$	
TSA-10	90	$\frac{3}{8}$	$\frac{3}{8}$	3	$\left(\frac{1}{32} \pm 0.010\right)$		0	8	90	2220	$\frac{3}{16}$	$\frac{3}{8}$	$\frac{9}{16}$
TSB-10	90	$\frac{3}{8}$	$\frac{3}{8}$	3			10	8	90	2220	$\frac{3}{16}$	$\frac{3}{8}$	$\frac{9}{16}$
TSC-10	60	$\frac{3}{8}$	$\frac{3}{8}$	3		30	38	60	2220	$\frac{3}{16}$	$\frac{3}{8}$	$\frac{9}{16}$	
TSD-10	60	$\frac{3}{8}$	$\frac{3}{8}$	3		40	38	60	2220	$\frac{3}{16}$	$\frac{3}{8}$	$\frac{9}{16}$	
TSE-10	45	$\frac{3}{8}$	$\frac{3}{8}$	3		45	53	45	2220	$\frac{3}{16}$	$\frac{3}{8}$	$\frac{9}{16}$	
TSF-10	45	$\frac{3}{8}$	$\frac{3}{8}$	3		55	53	45	2220	$\frac{3}{16}$	$\frac{3}{8}$	$\frac{9}{16}$	
TSA-12	90	$\frac{3}{4}$	$\frac{3}{4}$	$3\frac{1}{2}$		$\left(\frac{1}{32} \pm 0.010\right)$	0	8	90	2300	$\frac{3}{16}$	$\frac{7}{16}$	$\frac{9}{8}$
TSB-12	90	$\frac{3}{4}$	$\frac{3}{4}$	$3\frac{1}{2}$			10	8	90	2300	$\frac{3}{16}$	$\frac{7}{16}$	$\frac{9}{8}$
TSC-12	60	$\frac{3}{4}$	$\frac{3}{4}$	$3\frac{1}{2}$	30		38	60	2300	$\frac{3}{16}$	$\frac{7}{16}$	$\frac{9}{8}$	
TSD-12	60	$\frac{3}{4}$	$\frac{3}{4}$	$3\frac{1}{2}$	40		38	60	2300	$\frac{3}{16}$	$\frac{7}{16}$	$\frac{9}{8}$	
TSE-12	45	$\frac{3}{4}$	$\frac{3}{4}$	$3\frac{1}{2}$	45		53	45	2300	$\frac{3}{16}$	$\frac{7}{16}$	$\frac{9}{8}$	
TSF-12	45	$\frac{3}{4}$	$\frac{3}{4}$	$3\frac{1}{2}$	55		53	45	2300	$\frac{3}{16}$	$\frac{7}{16}$	$\frac{9}{8}$	



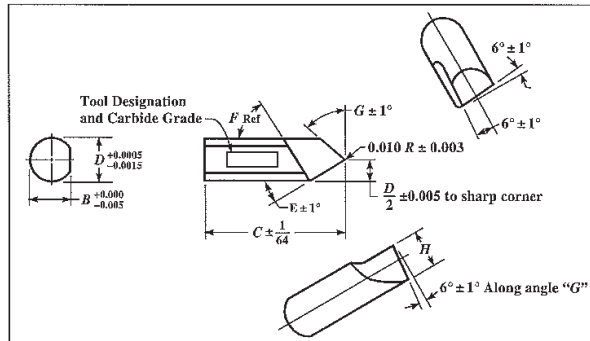

**Table 4. American National Standard Solid Carbide Round Boring Tools — Style SRC for 60° Boring Bar and Style SRE for 45° Boring Bar ANSI B212.1-1984 (R1997)**

Tool Designation	Bor. Bar Angle from Axis, Deg.	Shank Dimensions, Inches				Side Cut. Edge Angle E, Deg.	End Cut. Edge Angle G, Deg.	Shoulder Angle F, Deg.	
		Dia. D	Length C	Dim. Over Flat B	Nose Height H				
SRC-33	60	3/32	3/8	0.088	0.070	+0.000	30	38	60
SRE-33	45	3/32	3/8	0.088	0.070	-0.005	45	53	45
SRC-44	60	1/8	1/2	0.118	0.094	+0.000	30	38	60
SRE-44	45	1/8	1/2	0.118	0.094	-0.005	45	53	45
SRC-55	60	5/32	5/8	0.149	0.117	±0.005	30	38	60
SRE-55	45	5/32	5/8	0.149	0.117	±0.005	45	53	45
SRC-66	60	3/16	3/4	0.177	0.140	±0.005	30	38	60
SRE-66	45	3/16	3/4	0.177	0.140	±0.005	45	53	45
SRC-88	60	1/4	1	0.240	0.187	±0.005	30	38	60
SRE-88	45	1/4	1	0.240	0.187	±0.005	45	53	45
SRC-1010	60	5/16	1 1/4	0.300	0.235	±0.005	30	38	60
SRE-1010	45	5/16	1 1/4	0.300	0.235	±0.005	45	53	45

*Style Designations for Carbide Boring Tools:* Table 1 shows designations used to specify the styles of American Standard sintered carbide boring tools. The first letter denotes solid (S) or tipped (T). The second letter denotes square (S) or round (R). The side cutting edge angle is denoted by a third letter (A through H) to complete the style designation. Solid square and round bits with the mounting surfaces ground but the cutting edges unsharpened (Table 7) are designated using the same system except that the third letter indicating the side cutting edge angle is omitted.

*Size Designation of Carbide Boring Tools:* Specific sizes of boring tools are identified by the addition of numbers after the style designation. The first number denotes the diameter or square size in number of 1/32nds for types SS and SR and in number of 1/64ths for types

TS and TR. The second number denotes length in number of 1/8ths for types SS and SR. For styles TRG and TRH, a letter "U" after the number denotes a semi-finished tool (cutting edges unsharpened). Complete designations for the various standard sizes of carbide boring tools are given in Tables 2 through 7. In the diagrams in the tables, angles shown without tolerance are  $\pm 1^\circ$ .

Table 5. American National Standard Carbide-Tipped Round Boring Tools — Style TRC for 60° Boring Bar and Style TRE for 45° Boring Bar  
ANSI B212.1-1984 (R1997)

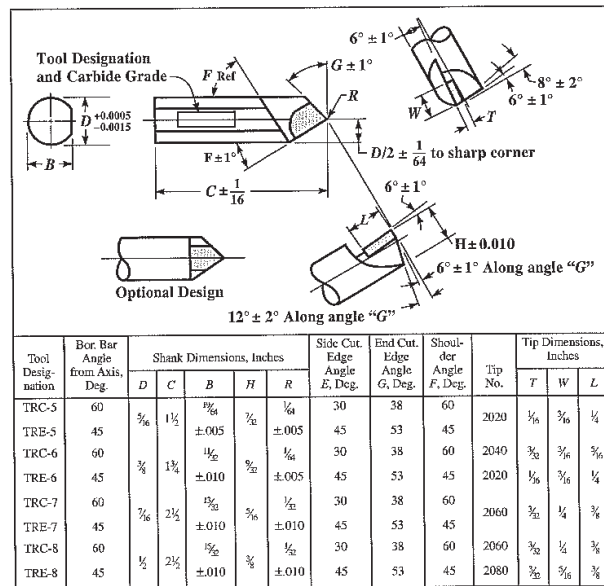

Examples of Tool Designation: The designation TSC-8 indicates: a carbide-tipped tool (T); square cross-section (S); 30-degree side cutting edge angle (C); and  $\frac{3}{16}$  or  $\frac{1}{2}$  inch square size (8).

The designation SRE-66 indicates: a solid carbide tool (S); round cross-section (R); 45 degree side cutting edge angle (E);  $\frac{3}{16}$  or  $\frac{3}{8}$  inch diameter (6); and  $\frac{3}{8}$  or  $\frac{1}{2}$  inch long (6).

The designation SS-610 indicates: a solid carbide tool (S); square cross-section (S);  $\frac{3}{16}$  or  $\frac{3}{8}$  inch square size (6);  $\frac{3}{8}$  or  $1\frac{1}{4}$  inches long (10).

It should be noted in this last example that the absence of a third letter (from A to H) indicates that the tool has its mounting surfaces ground but that the cutting edges are unsharpened.

STANDARD CARBIDE BORING TOOLS

Table 6. American National Standard Carbide-Tipped Round General-Purpose Square-End Boring Tools — Style TRG with 0° Rake and Style TRH with 10° Rake  
ANSI B2.1-1984 (R1997)

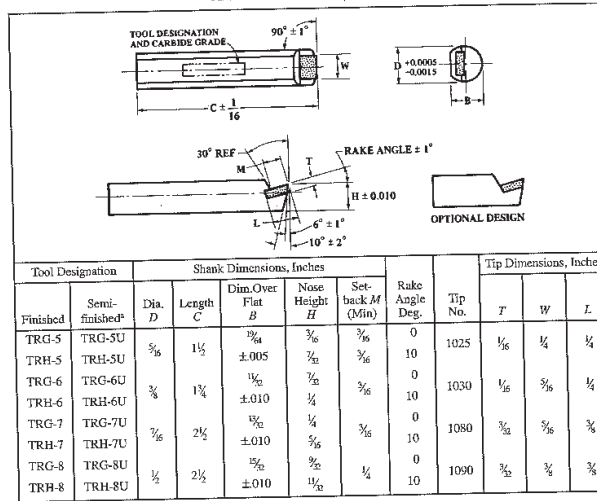

<sup>a</sup>Semifinished tool will be without Flat (B) and carbide unground on the end.

Table 7. Solid Carbide Square and Round Boring Tool Bits

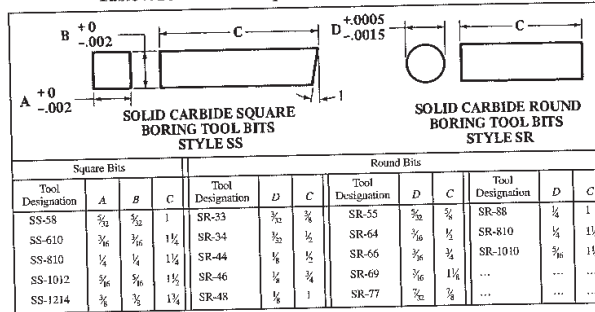

All dimensions are in inches.

Tolerance on Length: Through 1 inch, +1/32, -0; over 1 inch, +1/64, -0.

**Spade Drills and Drilling**

Spade drills are used to produce holes ranging in size from about 1 inch to 6 inches diameter, and even larger. Very deep holes can be drilled and blades are available for core drilling, counterboring, and for bottoming to a flat or contoured shape. There are two principal parts to a spade drill, the blade and the holder. The holder has a slot into which the blade fits; a wide slot at the back of the blade engages with a tongue in the holder slot to locate the blade accurately. A retaining screw holds the two parts together. The blade is usually made from high-speed steel, although cast nonferrous metal and cemented carbide-tipped blades are also available. Spade drill holders are classified by a letter symbol designating the range of blade sizes that can be held and by their length. Standard stub, short, long, and extra long holders are available; for very deep holes, special holders having wear strips to support and guide the drill are often used. Long, extra long, and many short length holders have coolant holes to direct cutting fluid, under pressure, to the cutting edges. In addition to its function in cooling and lubricating the tool, the cutting fluid also flushes the chips out of the hole. The shank of the holder may be straight or tapered; special automotive shanks are also used. A holder and different shank designs are shown in Fig. 1; Figs. 2a through Fig. 2f show some typical blades.

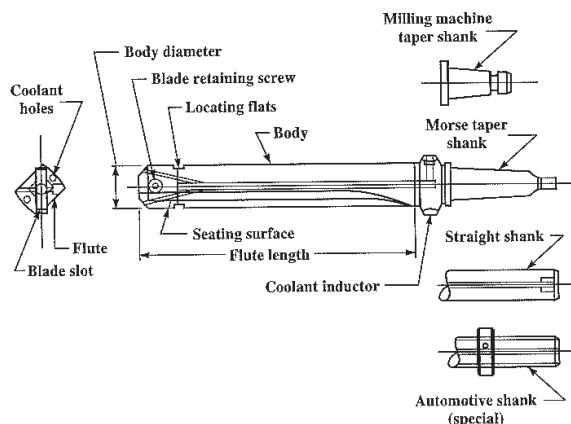
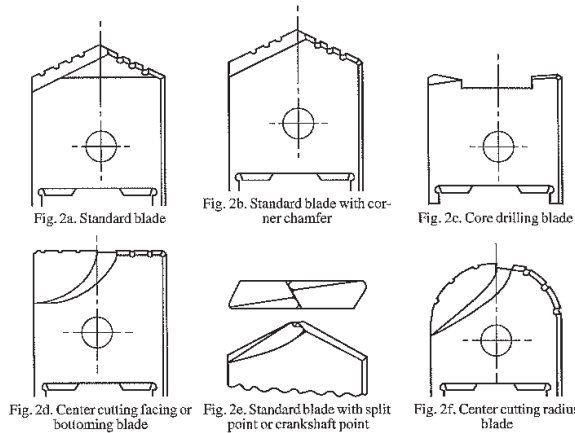

Fig. 1. Spade Drill Blade Holder

**Spade Drill Geometry.**—Metal separation from the work is accomplished in a like manner by both twist drills and spade drills, and the same mechanisms are involved for each. The two cutting lips separate the metal by a shearing action that is identical to that of chip formation by a single-point cutting tool. At the chisel edge, a much more complex condition exists. Here the metal is extruded sideways and at the same time is sheared by the rotation of the blunt wedge-formed chisel edge. This combination accounts for the very high thrust force required to penetrate the work. The chisel edge of a twist drill is slightly rounded, but on spade drills, it is a straight edge. Thus, it is likely that it is more difficult for the extruded metal to escape from the region of the chisel edge with spade drills. However, the chisel edge is shorter in length than on twist drills and the thrust for spade drilling is less.

## Typical Spade Drill Blades



Basic spade drill geometry is shown in Fig. 3. Normally, the point angle of a standard tool is 130 degrees and the lip clearance angle is 18 degrees, resulting in a chisel edge angle of 108 degrees. The web thickness is usually about  $\frac{1}{4}$  to  $\frac{5}{16}$  as thick as the blade thickness. Usually, the cutting edge angle is selected to provide this web thickness and to provide the necessary strength along the entire length of the cutting lip. A further reduction of the chisel edge length is sometimes desirable to reduce the thrust force in drilling. This reduction can be accomplished by grinding a secondary rake surface at the center or by grinding a split point, or crankshaft point, on the point of the drill.

The larger point angle of a standard spade drill—130 degrees as compared with 118 degrees on a twist drill—causes the chips to flow more toward the periphery of the drill, thereby allowing the chips to enter the flutes of the holder more readily. The rake angle facilitates the formation of the chip along the cutting lips. For drilling materials of average hardness, the rake angle should be 10 to 12 degrees; for hard or tough steels, it should be 5 to 7 degrees; and for soft and ductile materials, it can be increased to 15 to 20 degrees. The rake surface may be flat or rounded, and the latter design is called radial rake. Radial rake is usually ground so that the rake angle is maximum at the periphery and decreases uniformly toward the center to provide greater cutting edge strength at the center. A flat rake surface is recommended for drilling hard and tough materials in order to reduce the tendency to chipping and to reduce heat damage.

A most important feature of the cutting edge is the chip splitters, which are also called chip breaker grooves. Functionally, these grooves are chip dividers; instead of forming a single wide chip along the entire length of the cutting edge, these grooves cause formation of several chips that can be readily disposed of through the flutes of the holder. Chip splitters must be carefully ground to prevent the chips from packing in the grooves, which greatly reduces their effectiveness. Splitters should be ground perpendicular to the cutting lip and parallel to the surface formed by the clearance angle. The grooves on the two cut-

ting lips must not overlap when measured radially along the cutting lip. Fig. 4 and the accompanying table show the groove form and dimensions.

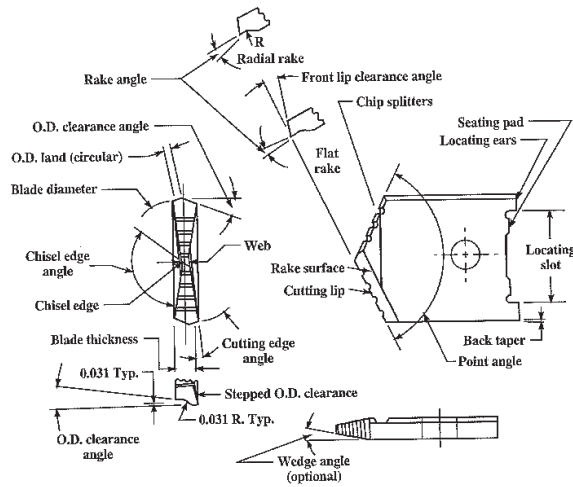

Fig. 3. Spade Drill Blade

On spade drills, the front lip clearance angle provides the relief. It may be ground on a drill grinding machine but usually it is ground flat. The normal front lip clearance angle is 8 degrees; in some instances, a secondary relief angle of about 14 degrees is ground below the primary clearance. The wedge angle on the blade is optional. It is generally ground on thicker blades having a larger diameter to prevent heel dragging below the cutting lip and to reduce the chisel edge length. The outside-diameter land is circular, serving to support and guide the blade in the hole. Usually it is ground to have a back taper of 0.001 to 0.002 inch per inch per side. The width of the land is approximately 20 to 25 per cent of the blade thickness. Normally, the outside-diameter clearance angle behind the land is 7 to 10 degrees. On many spade drill blades, the outside-diameter clearance surface is stepped about 0.030 inch below the land.

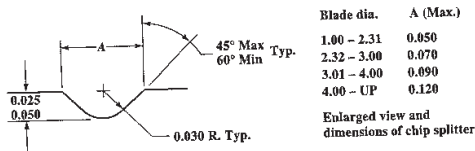

Fig. 4. Spade Drill Chip Splitter Dimensions

**Spade Drilling.**—Spade drills are used on drilling machines and other machine tools where the cutting tool rotates; they are also used on turning machines where the work

rotates and the tool is stationary. Although there are some slight operational differences, the methods of using spade drills are basically the same. An adequate supply of cutting fluid must be used, which serves to cool and lubricate the cutting edges; to cool the chips, thus making them brittle and more easily broken; and to flush chips out of the hole. Flood cooling from outside the hole can be used for drilling relatively shallow holes, of about one to two and one-half times the diameter in depth. For deeper holes, the cutting fluid should be injected through the holes in the drill. When drilling very deep holes, it is often helpful to blow compressed air through the drill in addition to the cutting fluid to facilitate ejection of the chips. Air at full shop pressure is throttled down to a pressure that provides the most efficient ejection. The cutting fluids used are light and medium cutting oils, water-soluble oils, and synthetics, and the type selected depends on the work material.

Starting a spade drill in the workpiece needs special attention. The straight chisel edge on the spade drill has a tendency to wander as it starts to enter the work, especially if the feed is too light. This wander can result in a mispositioned hole and possible breakage of the drill point. The best method of starting the hole is to use a stub or short-length spade drill holder and a blade of full size that should penetrate at least  $\frac{1}{8}$  inch at full diameter. The holder is then changed for a longer one as required to complete the hole to depth. Difficulties can be encountered if spotting with a center drill or starting drill is employed because the angles on these drills do not match the 130-degree point angle of the spade drill. Longer spade drills can be started without this starting procedure if the drill is guided by a jig bushing and if the holder is provided with wear strips.

Chip formation warrants the most careful attention as success in spade drilling is dependent on producing short, well-broken chips that can be easily ejected from the hole. Straight, stringy chips or chips that are wound like a clock spring cannot be ejected properly; they tend to pack around the blade, which may result in blade failure. The chip splitters must be functioning to produce a series of narrow chips along each cutting edge. Each chip must be broken, and for drilling ductile materials they should be formed into a "C" or "figure 9" shape. Such chips will readily enter the flutes on the holder and flow out of the hole.

Proper chip formation is dependent on the work material, the spade drill geometry, and the cutting conditions. Brittle materials such as gray cast iron seldom pose a problem because they produce a discontinuous chip, but austenitic stainless steels and very soft and ductile materials require much attention to obtain satisfactory chip control. Thinning the web or grinding a split point on the blade will sometimes be helpful in obtaining better chip control, as these modifications allow use of a heavier feed. Reducing the rake angle to obtain a tighter curl on the chip and grinding a corner chamfer on the tool will sometimes help to produce more manageable chips.

In most instances, it is not necessary to experiment with the spade drill blade geometry to obtain satisfactory chip control. Control usually can be accomplished by adjusting the cutting conditions; i.e., the cutting speed and the feed rate.

Normally, the cutting speed for spade drilling should be 10 to 15 per cent lower than that for an equivalent twist drill, although the same speed can be used if a lower tool life is acceptable. The recommended cutting speeds for twist drills on Tables 17 through 23, starting on page 1030, can be used as a starting point; however, they should be decreased by the percentage just given. It is essential to use a heavy feed rate when spade drilling to produce a thick chip, and to force the chisel edge into the work. In ductile materials, a light feed will produce a thin chip that is very difficult to break. The thick chip on the other hand, which often contains many rupture planes, will curl and break readily. Table 1 gives suggested feed rates for different spade drill sizes and materials. These rates should be used as a starting point and some adjustments may be necessary as experience is gained.

Table 1. Feed Rates for Spade Drilling

Material	Hardness, Bhn	Feed—Inches per Revolution					
		Spade Drill Diameter—Inches					
		1-1 1/4	1 1/2-2	2-3	3-4	4-5	5-8
Free Machining Steel	100-240	0.014	0.016	0.018	0.022	0.025	0.030
	240-325	0.010	0.014	0.016	0.020	0.022	0.025
Plain Carbon Steels	100-225	0.012	0.015	0.018	0.022	0.025	0.030
	225-275	0.010	0.013	0.015	0.018	0.020	0.025
Free Machining Alloy Steels	275-325	0.008	0.010	0.013	0.015	0.018	0.020
	150-250	0.014	0.016	0.018	0.022	0.025	0.030
Alloy Steels	250-325	0.012	0.014	0.016	0.018	0.020	0.025
	325-375	0.010	0.010	0.014	0.016	0.018	0.020
Tool Steels	125-180	0.012	0.015	0.018	0.022	0.025	0.030
	180-225	0.010	0.012	0.016	0.018	0.022	0.025
Water Hardening	225-325	0.009	0.010	0.013	0.015	0.018	0.020
	325-400	0.006	0.008	0.010	0.012	0.014	0.016
Shock Resisting	150-250	0.012	0.014	0.016	0.018	0.020	0.022
	175-225	0.012	0.014	0.015	0.016	0.017	0.018
Cold Work	200-250	0.007	0.008	0.009	0.010	0.011	0.012
	150-250	0.012	0.013	0.015	0.016	0.018	0.020
Mold	150-200	0.010	0.012	0.014	0.016	0.018	0.018
	Special-Purpose	150-225	0.010	0.012	0.014	0.016	0.016
High-Speed	200-240	0.010	0.012	0.013	0.015	0.017	0.018
	170-160	0.020	0.022	0.026	0.028	0.030	0.034
Gray Cast Iron	160-190	0.015	0.018	0.020	0.024	0.026	0.028
	190-240	0.012	0.014	0.016	0.018	0.020	0.022
Ductile or Nodular Iron	240-320	0.010	0.012	0.016	0.018	0.018	0.018
	140-190	0.014	0.016	0.018	0.020	0.022	0.024
Malleable Iron	190-250	0.012	0.014	0.016	0.018	0.018	0.020
	250-300	0.010	0.012	0.016	0.018	0.018	0.018
Ferritic	110-160	0.014	0.016	0.018	0.020	0.022	0.024
	160-220	0.012	0.014	0.016	0.018	0.020	0.020
Pearlitic	220-280	0.010	0.012	0.014	0.016	0.018	0.018
	Free Machining Stainless Steel	...	0.016	0.018	0.020	0.024	0.026
...		0.016	0.018	0.020	0.022	0.024	0.026
Austenitic	...	0.012	0.014	0.016	0.016	0.018	0.020
	...	0.012	0.014	0.016	0.016	0.018	0.020
Martensitic	...	0.010	0.012	0.012	0.014	0.016	0.018
	...	0.010	0.012	0.012	0.014	0.016	0.018
Aluminum Alloys	...	0.020	0.022	0.024	0.028	0.030	0.040
	(Soft)	0.016	0.018	0.020	0.026	0.028	0.030
Copper Alloys	(Hard)	0.010	0.012	0.014	0.016	0.018	0.018
	...	0.008	0.010	0.012	0.014	0.014	0.016
Titanium Alloys	...	0.008	0.010	0.012	0.014	0.014	0.016
	...	0.008	0.010	0.012	0.012	0.014	0.014



**Power Consumption and Thrust for Spade Drilling.**—In each individual setup, there are factors and conditions influencing power consumption that cannot be accounted for in a simple equation; however, those given below will enable the user to estimate power consumption and thrust accurately enough for most practical purposes. They are based on experimentally derived values of unit horsepower, as given in Table 2. As a word of caution, these values are for sharp tools. In spade drilling, it is reasonable to estimate that a dull tool will increase the power consumption and the thrust by 25 to 50 per cent. The unit horsepower values in the table are for the power consumed at the cutting edge, to which must be added the power required to drive the machine tool itself, in order to obtain the horsepower required by the machine tool motor. An allowance for power to drive the machine is provided by dividing the horsepower at the cutter by a mechanical efficiency factor,  $e_m$ . This factor can be estimated to be 0.90 for a direct spindle drive with a belt, 0.75 for a back gear drive, and 0.70 to 0.80 for geared head drives. Thus, for spade drilling the formulas are

$$hp_c = uhp \left( \frac{\pi D^2}{4} \right) f N$$

$$B_s = 148,500 uhp f D$$

$$hp_m = \frac{hp_c}{e_m}$$

$$f = \frac{f_m}{N}$$

where  $hp_c$  = horsepower at the cutter

$hp_m$  = horsepower at the motor

$B_s$  = thrust for spade drilling in pounds

$uhp$  = unit horsepower

$D$  = drill diameter in inches

$f$  = feed in inches per revolution

$f_m$  = feed in inches per minute

$N$  = spindle speed in revolutions per minute

$e_m$  = mechanical efficiency factor

**Table 2. Unit Horsepower for Spade Drilling**

Material	Hardness	uhp	Material	Hardness	uhp
Plain Carbon and Alloy Steel	85-200 Bhn	0.79	Titanium Alloys	250-375 Bhn	0.72
	200-275	0.94	High-Temp Alloys	200-360 Bhn	1.44
	275-375	1.00	Aluminum Alloys	...	0.22
	375-425	1.15	Magnesium Alloys	...	0.16
	45-52 Rc	1.44	Copper Alloys	20-80 Rb	0.43
Cast Irons	110-200 Bhn	0.5		80-100 Rb	0.72
	200-300	1.08			
Stainless Steels	135-275 Bhn	0.94			
	30-45 Rc	1.08			

*Example:* Estimate the horsepower and thrust required to drive a 2-inch diameter spade drill in AISI 1045 steel that is quenched and tempered to a hardness of 275 Bhn. From Table 17 on page 1030, the cutting speed,  $V$ , for drilling this material with a twist drill is 50 feet per minute. This value is reduced by 10 per cent for spade drilling and the speed selected is thus  $0.9 \times 50 = 45$  feet per minute. The feed rate (from Table 1, page 869) is 0.015 in/rev. and the unit horsepower from Table 2 above is 0.94. The machine efficiency factor is estimated to be 0.80 and it will be assumed that a 50 per cent increase in the unit horsepower must be allowed for dull tools.

Step 1. Calculate the spindle speed from the following formula:

$$N = \frac{12V}{\pi D}$$

where:  $N$  = spindle speed in revolutions per minute

$V$  = cutting speed in feet per minute

$D$  = drill diameter in inches

$$\text{Thus: } N = \frac{12 \times 45}{\pi \times 2} = 86 \text{ revolutions per minute}$$

Step 2. Calculate the horsepower at the cutter:

$$\text{hp}_c = \text{uhp} \left( \frac{\pi D^2}{4} \right) f N = 0.94 \left( \frac{\pi \times 2^2}{4} \right) 0.015 \times 86 = 3.8$$

Step 3. Calculate the horsepower at the motor and provide for a 50 per cent power increase for the dull tool:

$$\text{hp}_m = \frac{\text{hp}_c}{e_m} = \frac{3.8}{0.80} = 4.75 \text{ horsepower}$$

$$\text{hp}_m \text{ (with dull tool)} = 1.5 \times 4.75 = 7.125 \text{ horsepower}$$

Step 4. Estimate the spade drill thrust:

$$B_s = 148,500 \times \text{uhp} \times f D = 148,500 \times 0.94 \times 0.015 \times 2$$

$$= 4188 \text{ lb (for sharp tool)}$$

$$B_s = 1.5 \times 4188$$

$$= 6282 \text{ lb (for dull tool)}$$

**Trepanning.**—Cutting a groove in the form of a circle or boring or cutting a hole by removing the center or core in one piece is called trepanning. Shallow trepanning, also called face grooving, can be performed on a lathe using a single-point tool that is similar to a grooving tool but has a curved blade. Generally, the minimum outside diameter that can be cut by this method is about 3 inches and the maximum groove depth is about 2 inches. Trepanning is probably the most economical method of producing deep holes that are 2 inches, and larger, in diameter. Fast production rates can be achieved. The tool consists of a hollow bar, or stem, and a hollow cylindrical head to which a carbide or high-speed steel, single-point cutting tool is attached. Usually, only one cutting tool is used although for some applications a multiple cutter head must be used; e.g., heads used to start the hole have multiple tools. In operation, the cutting tool produces a circular groove and a residue core that enters the hollow stem after passing through the head. On outside-diameter exhaust trepanning tools, the cutting fluid is applied through the stem and the chips are flushed around the outside of the tool; inside-diameter exhaust tools flush the chips out through the stem with the cutting fluid applied from the outside. For starting the cut, a tool that cuts a starting groove in the work must be used, or the trepanning tool must be guided by a bushing. For holes less than about five diameters deep, a machine that rotates the trepanning tool can be used. Often, an ordinary drill press is satisfactory; deeper holes should be machined on a lathe with the work rotating. A hole diameter tolerance of  $\pm 0.010$  inch can be obtained easily by trepanning and a tolerance of  $\pm 0.001$  inch has sometimes been held. Hole runout can be held to  $\pm 0.003$  inch per foot and, at times, to  $\pm 0.001$  inch per foot. On heat-treated metal, a surface finish of 125 to 150  $\mu\text{m}$  AA can be obtained and on annealed metals 100 to 250  $\mu\text{m}$  AA is common.

## TAPS AND THREADING DIES

General dimensions and tap markings given in the ASME/ANSI Standard B94.9-1987 for straight fluted taps, spiral pointed taps, spiral pointed only taps, spiral fluted taps, fast spiral fluted taps, thread forming taps, pulley taps, nut taps, and pipe taps are shown in the tables on the pages that follow. This Standard also gives the thread limits for taps with cut threads and ground threads. The thread limits for cut thread and ground thread taps for screw threads are given in Tables 3 through 7 and Tables 8a and 8b; thread limits for cut thread and ground thread taps for pipe threads are given in Tables 9a through 10c. Taps recommended for various classes of Unified screw threads are given in Tables 11a through 14 in numbered sizes and Table 12 for nuts in fractional sizes.

**Types of Taps.**—Taps included in ASME/ANSI B94.9-1987 are categorized either by the style of fluting or by the specific application for which the taps are designed. The following types 1 through 6 are generally short in length, and were originally called “Hand Taps” but this design is generally used in machine applications. The remaining types have special lengths, which are detailed in the tables.

The thread size specifications for these types may be fractional or machine screw inch sizes, or metric sizes. The thread form may be ground or cut (unground) as further defined in each table. Additionally, the cutting chamfer on the thread may be Bottoming (B), Plug (P), or Taper (T).

(1) *Straight Flute Taps:* These taps have straight flutes of a number specified as either standard or optional, and are for general purpose applications.

(2) *Spiral Pointed Taps:* These taps have straight flutes and the cutting face of the first few threads is ground at an angle to force the chips ahead and prevent clogging in the flutes.

(3) *Spiral Pointed Only Taps:* These taps are made with the spiral point feature only without longitudinal flutes. These taps are especially suitable for tapping thin materials.

(4) *Spiral Fluted Taps:* These taps have right-hand helical flutes with a helix angle of 25 to 35 deg. These features are designed to help draw chips from the hole or to bridge a keyway.

(5) *Fast Spiral Fluted Taps:* These taps are similar to spiral fluted taps, except the helix angle is from 45 to 60 deg.

(6) *Thread Forming Taps:* These taps are fluteless except as optionally designed with one or more lubricating grooves. The thread form on the tap is lobed, so that there are a finite number of points contacting the work thread form. The tap does not cut, but forms the thread by extrusion.

(7) *Pulley Taps:* These taps have shanks that are extended in length by a standard amount for use where added reach is required. The shank is the same nominal diameter as the thread.

(8) *Nut Taps:* These taps are designed for tapping nuts on a low-production basis. Approximately one-half to three-quarters of the threaded portion has a chamfered section, which distributes the cutting over many teeth and facilitates entering the hole to be tapped. The length overall, the length of the thread, and the length of the shank are appreciably longer than on a regular straight fluted tap.

(9) *Pipe Taps:* These taps are used to produce standard straight or tapered pipe threads.

**Definitions of Tap Terms.**—The definitions that follow are taken from ANSI/ASME B94.9 but include only the more important terms. Some tap terms are the same as screw thread terms; therefore, see *Definitions of Screw Threads* starting on page 1707.

*Back Taper:* A gradual decrease in the diameter of the thread form on a tap from the chamfered end of the land toward the back, which creates a slight radial relief in the threads.

*Base of Thread:* Coincides with the cylindrical or conical surface from which the thread projects.

**Chamfer:** Tapering of the threads at the front end of each land or chaser of a tap by cutting away and relieving the crest of the first few teeth to distribute the cutting action over several teeth.

**Chamfer Angle:** Angle formed between the chamfer and the axis of the tap measured in an axial plane at the cutting edge.

**Chamfer Relief Angle:** Complement of the angle formed between a tangent to the relieved surface at the cutting edge and a radial line to the same point on the cutting edge.

**Core Diameter:** Diameter of a circle which is tangent to the bottom of the flutes at a given point on the axis.

**First Full Thread:** First full thread on the cutting edge back of the chamfer. It is at this point that rake, hook, and thread elements are measured.

**Crest Clearance:** Radial distance between the root of the internal thread and the crest of the external thread of the coaxially assembled design forms of mating threads.

**Class of Thread:** Designation of the class that determines the specification of the size, allowance, and tolerance to which a given threaded product is to be manufactured. It is not applicable to the tools used for threading.

Tap Terms

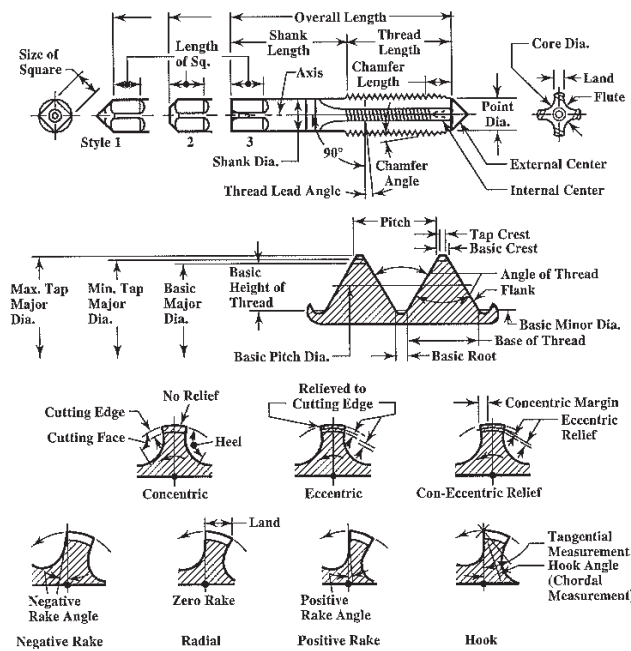

*Flank Angle:* Angle between the individual flank and the perpendicular to the axis of the thread, measured in an axial plane. A flank angle of a symmetrical thread is commonly termed the "half angle of thread."

*Flank—Leading:* 1) Flank of a thread facing toward the chamfered end of a threading tool; and 2) The leading flank of a thread is the one which, when the thread is about to be assembled with a mating thread, faces the mating thread.

*Flank—Trailing:* The trailing flank of a thread is the one opposite the leading flank.

*Flutes:* Longitudinal channels formed in a tap to create cutting edges on the thread profile and to provide chip spaces and cutting fluid passages. On a parallel or straight thread tap they may be straight, angular or helical; on a taper thread tap they may be straight, angular or spiral.

*Flute-Angular:* A flute lying in a plane intersecting the tool axis at an angle.

*Flute-Helical:* A flute with uniform axial lead and constant helix in a helical path around the axis of a cylindrical tap.

*Flute-Spiral:* A flute with uniform axial lead in a spiral path around the axis of a conical tap.

*Flute Lead Angle:* Angle at which a helical or spiral cutting edge at a given point makes with an axial plane through the same point.

*Flute-Straight:* A flute which forms a cutting edge lying in an axial plane.

*Front Taper:* A gradual increase in the diameter of the thread form on a tap from the leading end of the tool toward the back.

*Heel:* Edge of the land opposite the cutting edge.

*Hook Angle:* Inclination of a concave cutting face, usually specified either as Chordal Hook or Tangential Hook.

*Hook-Chordal Angle:* Angle between the chord passing through the root and crest of a thread form at the cutting face, and a radial line through the crest at the cutting edge.

*Hook-Tangential Angle:* Angle between a line tangent to a hook cutting face at the cutting edge and a radial line to the same point.

*Interrupted Thread Tap:* A tap having an odd number of lands with alternate teeth in the thread helix removed. In some designs alternate teeth are removed only for a portion of the thread length.

*Land:* One of the threaded sections between the flutes of a tap.

*Lead:* Distance a screw thread advances axially in one complete turn.

*Lead Error:* Deviation from prescribed limits.

*Lead Deviation:* Deviation from the basic nominal lead.

*Progressive Lead Deviation:* (1) On a straight thread the deviation from a true helix where the thread helix advances uniformly. (2) On a taper thread the deviation from a true spiral where the thread spiral advances uniformly.

*Length of Thread:* The length of the thread of the tap includes the chamfered threads and the full threads but does not include an external center. It is indicated by the letter "B" in the illustrations at the heads of the tables.

*Limits:* The limits of size are the applicable maximum and minimum sizes.

*Major Diameter:* On a straight thread the major diameter is that of the major cylinder. On a taper thread the major diameter at a given position on the thread axis is that of the major cone at that position.

*Minor Diameter:* On a straight thread the minor diameter is that of the minor cylinder. On a taper thread the minor diameter at a given position on the thread axis is that of the minor cone at that position.

*Pitch Diameter (Simple Effective Diameter):* On a straight thread, the pitch diameter is the diameter of the imaginary coaxial cylinder, the surface of which would pass through the thread profiles at such points as to make the width of the groove equal to one-half the basic pitch. On a perfect thread this coincidence occurs at the point where the widths of the thread and groove are equal. On a taper thread, the pitch diameter at a given position on the thread axis is the diameter of the pitch cone at that position.

*Point Diameter:* Diameter at the cutting edge of the leading end of the chamfered section.

*Rake:* Angular relationship of the straight cutting face of a tooth with respect to a radial line through the crest of the tooth at the cutting edge. Positive rake means that the crest of the cutting face is angularly ahead of the balance of the cutting face of the tooth. Negative rake means that the crest of the cutting face is angularly behind the balance of the cutting face of the tooth. Zero rake means that the cutting face is directly on a radial line.

*Relief:* Removal of metal behind the cutting edge to provide clearance between the part being threaded and the threaded land.

*Relief-Center:* Clearance produced on a portion of the tap land by reducing the diameter of the entire thread form between cutting edge and heel.

*Relief-Chamfer:* Gradual decrease in land height from cutting edge to heel on the chamfered portion of the land on a tap to provide radial clearance for the cutting edge.

*Relief-Con-eccentric Thread:* Radial relief in the thread form starting back of a concentric margin.

*Relief-Double Eccentric Thread:* Combination of a slight radial relief in the thread form starting at the cutting edge and continuing for a portion of the land width, and a greater radial relief for the balance of the land.

*Relief-Eccentric Thread:* Radial relief in the thread form starting at the cutting edge and continuing to the heel.

*Relief-Flatted Land:* Clearance produced on a portion of the tap land by truncating the thread between cutting edge and heel.

*Relief-Grooved Land:* Clearance produced on a tap land by forming a longitudinal groove in the center of the land.

*Relief-Radial:* Clearance produced by removal of metal from behind the cutting edge. Taps should have the chamfer relieved and should have back taper, but may or may not have relief in the angle and on the major diameter of the threads. When the thread angle is relieved, starting at the cutting edge and continuing to the heel, the tap is said to have "eccentric" relief. If the thread angle is relieved back of a concentric margin (usually one-third of land width), the tap is said to have "con-eccentric" relief.

*Size-Actual:* Measured size of an element on an individual part.

*Size-Basic:* That size from which the limits of size are derived by the application of allowances and tolerances.

*Size-Functional:* The functional diameter of an external or internal thread is the pitch diameter of the enveloping thread of perfect pitch, lead and flank angles, having full depth of engagement but clear at crests and roots, and of a specified length of engagement. It may be derived by adding to the pitch diameter in an external thread, or subtracting from the pitch diameter in an internal thread, the cumulative effects of deviations from specified profile, including variations in lead and flank angle over a specified length of engagement. The effects of taper, out-of-roundness, and surface defects may be positive or negative on either external or internal threads.

*Size-Nominal:* Designation used for the purpose of general identification.

*Spiral Flute:* See *Flutes*.

*Spiral Point:* Angular fluting in the cutting face of the land at the chamfered end. It is formed at an angle with respect to the tap axis of opposite hand to that of rotation. Its length is usually greater than the chamfer length and its angle with respect to the tap axis is usually made great enough to direct the chips ahead of the tap. The tap may or may not have longitudinal flutes.

*Thread Lead Angle:* On a straight thread, the lead angle is the angle made by the helix of the thread at the pitch line with a plane perpendicular to the axis. On a taper thread, the lead angle at a given axial position is the angle made by the conical spiral of the thread, with the plane perpendicular to the axis, at the pitch line.

**Table 3. ANSI Standard Fraction-Size Taps — Cut Thread Limits**  
ASME/ANSI B94.9-1987

Tap Size	Threads per Inch			Major Diameter			Pitch Diameter		
	NC UNC	NF UNF	NS UNS	Basic	Min.	Max.	Basic	Min.	Max.
1/8	...	...	40	0.1250	0.1266	0.1286	0.1088	0.1090	0.1105
5/32	...	...	32	0.1563	0.1585	0.1605	0.1360	0.1365	0.1380
3/16	...	...	24	0.1875	0.1903	0.1923	0.1604	0.1609	0.1624
1/4	...	...	32	0.1875	0.1897	0.1917	0.1672	0.1677	0.1692
1/4	20	...	...	0.2500	0.2532	0.2557	0.2175	0.2180	0.2200
1/4	...	28	...	0.2500	0.2524	0.2549	0.2268	0.2273	0.2288
5/16	18	...	...	0.3125	0.3160	0.3185	0.2764	0.2769	0.2789
5/16	...	24	...	0.3125	0.3153	0.3178	0.2854	0.2859	0.2874
3/8	16	...	...	0.3750	0.3789	0.3814	0.3344	0.3349	0.3369
3/8	...	24	...	0.3750	0.3778	0.3803	0.3479	0.3484	0.3499
7/16	14	...	...	0.4375	0.4419	0.4449	0.3911	0.3916	0.3941
7/16	...	20	...	0.4375	0.4407	0.4437	0.4050	0.4055	0.4075
1/2	13	...	...	0.5000	0.5047	0.5077	0.4500	0.4505	0.4530
1/2	...	20	...	0.5000	0.5032	0.5062	0.4675	0.4680	0.4700
9/16	12	...	...	0.5625	0.5675	0.5705	0.5084	0.5089	0.5114
9/16	...	18	...	0.5625	0.5660	0.5690	0.5264	0.5269	0.5289
5/8	11	...	...	0.6250	0.6304	0.6334	0.5660	0.5665	0.5690
5/8	...	18	...	0.6250	0.6285	0.6315	0.5889	0.5894	0.5914
3/4	10	...	...	0.7500	0.7559	0.7599	0.6850	0.6855	0.6885
3/4	...	16	...	0.7500	0.7539	0.7579	0.7094	0.7099	0.7124
7/8	9	...	...	0.8750	0.8820	0.8860	0.8028	0.8038	0.8068
7/8	...	14	...	0.8750	0.8799	0.8839	0.8286	0.8296	0.8321
1	8	...	...	1.0000	1.0078	1.0118	0.9188	0.9198	0.9228
1	...	12	...	1.0000	1.0055	1.0095	0.9459	0.9469	0.9494
1	...	...	14	1.0000	1.0049	1.0089	0.9536	0.9546	0.9571
1 1/8	7	...	...	1.1250	1.1337	1.1382	1.0322	1.0332	1.0367
1 1/8	...	12	...	1.1250	1.1305	1.1350	1.0709	1.0719	1.0749
1 1/8	7	...	...	1.2500	1.2587	1.2632	1.1572	1.1582	1.1617
1 1/4	...	12	...	1.2500	1.2555	1.2600	1.1959	1.1969	1.1999
1 3/8	6	...	...	1.3750	1.3850	1.3895	1.2667	1.2677	1.2712
1 3/8	...	12	...	1.3750	1.3805	1.3850	1.3209	1.3219	1.3249
1 1/2	6	...	...	1.5000	1.5100	1.5145	1.3917	1.3927	1.3962
1 1/2	...	12	...	1.5000	1.5055	1.5100	1.4459	1.4469	1.4499
1 3/4	5	...	...	1.7500	1.7602	1.7657	1.6201	1.6216	1.6256
2	4 1/2	...	...	2.0000	2.0111	2.0166	1.8557	1.8572	1.8612

All dimensions are given in inches.

*Lead Tolerance:* Plus or minus 0.003 inch max. per inch of thread.

*Angle Tolerance:* Plus or minus 35 min. in half angle or 53 min. in full angle for 4 1/2 to 5 1/2 thds. per in.; 40 min. half angle and 60 min. full angle for 6 to 9 thds.; 45 min. half angle and 68 min. full angle for 10 to 28 thds.; 60 min. half angle and 90 min. full angle for 30 to 64 thds. per in.

TAPS AND THREADING DIES

877

Table 4. ANSI Standard Fractional-Size Taps — Ground Thread Limits ASME/ANSI B94.9-1987

Size	Threads per inch		Major Diameter			Pitch Diameter Limits						H3 & H4 Limits		H4, H5 <sup>a</sup> & H6 Limits		
	NC UNC	NF UNF	NS UNS	Basic	Min.	Max.	H1 Limit		H2 Limit		H3 & H4 Limits		Min.	Max.	Min.	Max.
							Mdn.	Max.	Mdn.	Max.	Mdn.	Max.				
1/2	20	...	...	0.2500	0.2533	0.2565	0.2175	0.2180	0.2180	0.2180	0.2185	0.2185	0.2190	0.2195	0.2195	0.2200
1/4	18	...	...	0.2500	0.2533	0.2546	0.2268	0.2273	0.2273	0.2273	0.2278	0.2278	0.2283	0.2283	0.2288	0.2288
3/8	16	...	...	0.3125	0.3161	0.3197	0.2764	0.2769	0.2769	0.2769	0.2774	0.2774	0.2779	0.2784	0.2789	0.2789
1/2	14	...	...	0.3750	0.3790	0.3831	0.3344	0.3349	0.3349	0.3349	0.3354	0.3354	0.3359	0.3364	0.3369	0.3369
3/4	12	...	...	0.3750	0.3777	0.3804	0.3479	0.3484	0.3484	0.3484	0.3489	0.3489	0.3494	0.3499	0.3499	0.3499
1	11	...	...	0.4375	0.4422	0.4468	0.3911	...	...	0.3916	0.3921	0.3921	0.3926	0.3931	0.3936	0.3936
1 1/8	10	...	...	0.4375	0.4408	0.4440	0.4050	...	...	0.4055	0.4060	0.4065	0.4070	0.4075	0.4075	0.4075
1 1/4	9	...	...	0.5000	0.5050	0.5100	0.4500	0.4500	0.4500	0.4505	0.4510	0.4515	0.4520	0.4525	0.4525	0.4525
1 3/8	8	...	...	0.5000	0.5033	0.5065	0.4675	0.4675	0.4680	0.4685	0.4685	0.4690	0.4695	0.4700	0.4700	0.4700
1 1/2	7	...	...	0.5625	0.5679	0.5733	...	...	...	0.5269	0.5274	0.5279	0.5284	0.5289	0.5294	0.5294
1 3/4	6	...	...	0.6250	0.6309	0.6368	...	...	...	0.5665	0.5670	0.5675	0.5680	0.5685	0.5690	0.5690
2	5	...	...	0.6250	0.6286	0.6322	...	...	...	0.5894	0.5899	0.5904	0.5909	0.5914	0.5919	0.5919
2 1/8	4	...	...	0.6875	0.6934	0.6993	...	...	...	...	0.6295	0.6300	0.6305	0.6310	0.6315	0.6315
2 1/4	3	...	...	0.6875	0.6915	0.6956	...	...	...	...	0.6479	0.6484	0.6489	0.6494	0.6499	0.6499
2 3/8	2	...	...	0.7500	0.7565	0.7630	...	...	...	...	0.6860	0.6865	0.6870	0.6875	0.6880	0.6880
2 1/2	1	...	...	0.7500	0.7540	0.7581	0.7094	0.7094	0.7099	0.7104	0.7104	0.7109	0.7114	0.7119	0.7124	0.7124
3	1	...	...	0.8750	0.8822	0.8894	...	...	...	...	0.8043	0.8048	0.8053	0.8058	0.8063	0.8063
3 1/8	1	...	...	1.0000	1.0081	1.0162	...	...	...	...	0.8301	0.8306	0.8311	0.8316	0.8321	0.8321
3 1/4	1	...	...	1.0000	1.0054	1.0108	...	...	...	...	0.9203	0.9208	0.9213	0.9218	0.9223	0.9223
3 1/2	1	...	...	1.0000	1.0054	1.0108	...	...	...	...	0.9474	0.9479	0.9484	0.9489	0.9494	0.9494
4	1	...	...	1.0000	1.0047	1.0093	...	...	...	...	0.9551	0.9556	0.9561	0.9566	0.9571	0.9571

<sup>a</sup>H4 limit value.  
<sup>b</sup>H5 limit value.  
<sup>c</sup>H6 li.



**Table 5. ANSI Standard Fractional-Size Taps—Ground Thread Limits (ASME/ANSI B94.9-1987)**

Size	Threads per Inch			Major Diameter			Pitch Diameter Limits		
	NC UNC	NF UNF	NS UNS	Basic	Min.	Max.	Basic Pitch Dia.	H4 Limit	
								Min.	Max.
1 1/8	7	...	...	1.1250	1.1343	1.1436	1.0322	1.0332	1.0342
1 1/8	...	12	...	1.1250	1.1304	1.1358	1.0709	1.0719	1.0729
1 1/4	7	...	...	1.2500	1.2593	1.2686	1.1572	1.1582	1.1592
1 1/4	...	12	...	1.2500	1.2554	1.2608	1.1959	1.1969	1.1979
1 3/8	6	...	...	1.3750	1.3859	1.3967	1.2667	1.2677	1.2687
1 3/8	...	12	...	1.3750	1.3804	1.3858	1.3209	1.3219	1.3229
1 1/2	6	...	...	1.5000	1.5109	1.5217	1.3917	1.3927	1.3937
1 1/2	...	12	...	1.5000	1.5054	1.5108	1.4459	1.4469	1.4479

All dimensions are given in inches.

Lead Tolerance: Plus or minus 0.0005 inch within any two threads not farther apart than one inch.

Angle Tolerance: Plus or minus 25 min. in half angle for 6 to 9 threads per inch; plus or minus 30 min. in half angle for 10 to 28 threads per inch.

For an explanation of the significance of the H4 limit value range see *Standard System Tap Thread Limits and Identification for Unified Inch Screw Threads, Ground Thread* starting on page 896.

**Table 6. ANSI Standard Machine Screw Taps—Ground Thread Limits (ASME/ANSI B94.9-1987)**

Size	Threads per Inch			Major Diameter			Pitch Diameter Limits*						
	NC UNC	NF UNF	NS UNS	Basic	Min.	Max.	Basic Pitch Dia.	H1 Limit		H2 Limit		H3 Limit	
								Min.	Max.	Min.	Max.	Min.	Max.
0	...	80	...	0.0600	0.0605	0.0616	0.0519	0.0519	0.0524	0.0524	0.0529	...	...
1	64	...	...	0.0730	0.0736	0.0750	0.0629	0.0629	0.0634	0.0634	0.0639	...	...
1	...	72	...	0.0730	0.0736	0.0748	0.0640	0.0640	0.0645	0.0645	0.0650	...	...
2	56	...	...	0.0860	0.0867	0.0883	0.0744	0.0744	0.0749	0.0749	0.0754	...	...
2	...	64	...	0.0860	0.0866	0.0880	0.0759	...	...	0.0764	0.0769	...	...
3	48	...	...	0.0990	0.0999	0.1017	0.0855	0.0855	0.0860	0.0860	0.0865	...	...
3	...	56	...	0.0990	0.0997	0.1013	0.0874	0.0874	0.0879	0.0879	0.0884	...	...
4	...	...	36	0.1120	0.1135	0.1156	0.0940	...	...	0.0945	0.0950	...	...
4	40	...	...	0.1120	0.1133	0.1152	0.0958	0.0958	0.0963	0.0963	0.0968	...	...
4	...	48	...	0.1120	0.1129	0.1147	0.0985	0.0985	0.0990	0.0990	0.0995	...	...
5	40	...	...	0.1250	0.1263	0.1282	0.1088	0.1088	0.1093	0.1093	0.1098	...	...
5	...	44	...	0.1250	0.1263	0.1280	0.1102	...	...	0.1107	0.1112	...	...
6	32	...	...	0.1380	0.1401	0.1421	0.1177	0.1177	0.1182	0.1182	0.1187	0.1187	0.1192
6	...	40	...	0.1380	0.1393	0.1412	0.1218	0.1218	0.1223	0.1223	0.1228	...	...
8	32	...	...	0.1640	0.1661	0.1681	0.1437	0.1437	0.1442	0.1442	0.1447	0.1447	0.1452
8	...	36	...	0.1640	0.1655	0.1676	0.1460	...	...	0.1465	0.1470	...	...
10	24	...	...	0.1900	0.1927	0.1954	0.1629	0.1629	0.1634	0.1634	0.1639	0.1639	0.1644
10	...	32	...	0.1900	0.1921	0.1941	0.1697	0.1697	0.1702	0.1702	0.1707	0.1707	0.1712
12	24	...	...	0.2160	0.2187	0.2214	0.1889	...	...	...	...	0.1899	0.1904
12	...	28	...	0.2160	0.2183	0.2206	0.1928	...	...	...	...	0.1938	0.1943

\*H7 limits (formerly designated as G) apply to same threads as H3 limits with the exception of the 12-24 and 12-28 threads. H7 limits have minimum and maximum major diameters 0.0020 inch larger than shown and minimum and maximum pitch diameters 0.0020 inch larger than shown for H3 limits.

All dimensions are given in inches.

Lead Tolerance: Plus or minus 0.0005 inch within any two threads not farther apart than one inch.

Angle Tolerance: Plus or minus 30 min. in half angle for 20 to 80 threads per inch.

For an explanation of the significance of the limit value ranges see *Standard System Tap Thread Limits and Identification for Unified Inch Screw Threads, Ground Thread* starting on page 896.

**Table 7. ANSI Standard Machine Screw Taps — Cut Threads Limits**  
ASME/ANSI B94.9-1987

Size	Threads per Inch			Major Diameter			Pitch Diameter		
	NC UNC	NF UNF	NS UNS	Basic	Min.	Max.	Basic	Min.	Max.
0	...	80	...	0.0600	0.0609	0.0624	0.0519	0.0521	0.0531
1	64	...	...	0.0730	0.0740	0.0755	0.0629	0.0631	0.0641
1	...	72	...	0.0730	0.0740	0.0755	0.0640	0.0642	0.0652
2	56	...	...	0.0860	0.0872	0.0887	0.0744	0.0746	0.0756
2	...	64	...	0.0860	0.0870	0.0885	0.0759	0.0761	0.0771
3	48	...	...	0.0990	0.1003	0.1018	0.0835	0.0857	0.0867
3	...	56	...	0.0990	0.1002	0.1017	0.0874	0.0876	0.0886
4	...	36	...	0.1120	0.1137	0.1157	0.0940	0.0942	0.0957
4	40	...	...	0.1120	0.1136	0.1156	0.0958	0.0960	0.0975
4	...	48	...	0.1120	0.1133	0.1153	0.0985	0.0987	0.1002
5	40	...	...	0.1250	0.1266	0.1286	0.1088	0.1090	0.1105
6	32	...	...	0.1380	0.1402	0.1422	0.1177	0.1182	0.1197
6	...	36	...	0.1380	0.1397	0.1417	0.1200	0.1202	0.1217
6	...	40	...	0.1380	0.1396	0.1416	0.1218	0.1220	0.1235
8	32	...	...	0.1640	0.1662	0.1682	0.1437	0.1442	0.1457
8	...	36	...	0.1640	0.1657	0.1677	0.1460	0.1462	0.1477
8	...	40	...	0.1640	0.1656	0.1676	0.1478	0.1480	0.1495
10	24	...	...	0.1900	0.1928	0.1948	0.1629	0.1634	0.1649
10	...	32	...	0.1900	0.1922	0.1942	0.1697	0.1702	0.1717
12	24	...	...	0.2160	0.2188	0.2208	0.1889	0.1894	0.1909
12	...	28	...	0.2160	0.2184	0.2204	0.1938	0.1933	0.1948
14	...	24	...	0.2420	0.2448	0.2473	0.2149	0.2154	0.2174

All dimensions are given in inches.

*Lead Tolerance:* Plus or minus 0.003 inch per inch of thread. *Angle Tolerance:* Plus or minus 45 min. in half angle and 68 min. in full angle for 20 to 28 threads per inch; plus or minus 60 min. in half angle and 90 min. in full angle for 30 or more threads per inch.

**Table 8a. ANSI Standard Metric Tap Ground Thread Limits in Inches — M Profile**  
ASME/ANSI B94.9-1987

Nominal Diam. mm	Pitch, mm	Major Diameter (inches)			Pitch Diameter (inches)		
		Basic	Min	Max	Basic	Min	Max
1.6	0.35	0.06299	0.06409	0.06508	0.05406	0.05500	0.05559
2	0.4	0.07874	0.08000	0.08098	0.06850	0.06945	0.07004
2.5	0.45	0.09843	0.09984	0.10083	0.08693	0.08787	0.08846
3	0.5	0.11811	0.11969	0.12067	0.10531	0.10626	0.10685
3.5	0.6	0.13780	0.13969	0.14067	0.12244	0.12370	0.12449
4	0.7	0.15748	0.15969	0.16130	0.13957	0.14083	0.14161
4.5	0.75	0.17717	0.17953	0.18114	0.15759	0.15925	0.16004
5	0.8	0.19685	0.19937	0.20098	0.17638	0.17764	0.17843
6	1	0.23622	0.23937	0.24098	0.21063	0.21220	0.21319
7	1	0.27559	0.27874	0.28035	0.25000	0.25157	0.25256
8	1.25	0.31496	0.31890	0.32142	0.28299	0.28433	0.28555
10	1.5	0.39370	0.39843	0.40094	0.35525	0.35720	0.35843
12	1.75	0.47244	0.47795	0.48047	0.42768	0.42953	0.43075
14	2	0.55118	0.55748	0.56000	0.50004	0.50201	0.50362
16	2	0.62992	0.63622	0.63874	0.57878	0.58075	0.58236
20	2.5	0.78740	0.79538	0.79780	0.72346	0.72543	0.72705
24	3	0.94488	0.95433	0.95827	0.86815	0.87063	0.87224
30	3.5	1.18110	1.19213	1.19606	1.09161	1.09417	1.09622
36	4	1.41732	1.42992	1.43386	1.31504	1.31760	1.31965

Basic pitch diameter is the same as minimum pitch diameter of internal thread, Class 6H as shown in table starting on page 1769.

Pitch diameter limits are designated in the Standard as D3 for 1.6 to 3 mm diameter sizes, incl.; D4 for 3.5 to 5 mm sizes, incl.; D5 for 6 and 8 mm sizes; D6 for 10 and 12 mm sizes; D7 for 14 to 20 mm sizes, incl.; D8 for 24 mm size; and D9 for 30 and 36 mm sizes.

Angle tolerances are plus or minus 30 minutes in half angle for pitches ranging from 0.35 through 2.5 mm, incl. and plus or minus 25 minutes in half angle for pitches ranging from 3 to 4 mm, incl.

A maximum deviation of plus or minus 0.0005 inch within any two threads not farther apart than one inch is permitted.

**Table 8b. ANSI Standard Metric Tap Ground Thread Limits in Millimeters—  
M Profile ASME/ANSI B94.9-1987**

Nominal Diam. mm	Pitch, mm	Major Diameter (mm)			Pitch Diameter (mm)		
		Basic	Min	Max	Basic	Min	Max
1.6	0.35	1.600	1.628	1.653	1.373	1.397	1.412
2	0.4	2.000	2.032	2.057	1.740	1.764	1.779
2.5	0.45	2.500	2.536	2.561	2.208	2.232	2.247
3	0.5	3.000	3.040	3.065	2.675	2.699	2.714
3.5	0.6	3.500	3.548	3.573	3.110	3.142	3.162
4	0.7	4.000	4.056	4.097	3.545	3.577	3.597
4.5	0.75	4.500	4.560	4.601	4.013	4.045	4.065
5	0.8	5.000	5.064	5.105	4.480	4.512	4.532
6	1	6.000	6.080	6.121	5.350	5.390	5.415
7	1	7.000	7.080	7.121	6.350	6.390	6.415
8	1.25	8.000	8.100	8.164	7.188	7.222	7.253
10	1.5	10.000	10.120	10.184	9.026	9.073	9.104
12	1.75	12.000	12.140	12.204	10.863	10.910	10.941
14	2	14.000	14.160	14.224	12.701	12.751	12.792
16	2	16.000	16.160	16.224	14.701	14.751	14.792
20	2.5	20.000	20.200	20.264	18.376	18.426	18.467
24	3	24.000	24.240	24.340	22.051	22.114	22.155
30	3.5	30.000	30.280	30.350	27.727	27.792	27.844
36	4	36.000	36.320	36.420	33.402	33.467	33.519

Basic pitch diameter is the same as minimum pitch diameter of internal thread, Class 6H as shown in table starting on page 1769.

Pitch diameter limits are designated in the Standard as D3 for 1.6 to 3 mm diameter sizes, incl.; D4 for 3.5 to 5 mm sizes, incl.; D5 for 6 and 8 mm sizes; D6 for 10 and 12 mm sizes; D7 for 14 to 20 mm sizes, incl.; D8 for 24 mm size; and D9 for 30 and 36 mm sizes.

Angle tolerances are plus or minus 30 minutes in half angle for pitches ranging from 0.35 through 2.5 mm, incl. and plus or minus 25 minutes in half angle for pitches ranging from 3 to 4 mm, incl.

A maximum lead deviation of plus or minus 0.013 mm within any two threads not farther apart than 25 mm is permitted.

**Table 9a. ANSI Standard Taper Pipe Taps — Cut Thread Tolerances for NPT and Ground Thread Tolerances for NPT, NPTF, and ANPT ASME/ANSI B94.9-1987**

Nominal Size	Threads per Inch NPT, NPTF or ANPT	Gage Measurement <sup>a</sup>			Taper per Foot, Inches			
		Projection Inches	Tolerance Plus or Minus		Cut Thread		Ground Thread	
			Cut Thread	Ground Thread	Min.	Max.	Min.	Max.
1/8	27	0.312	1/16	1/16	2/32	2/32	2/32	2/32
1/8	27	0.312	1/16	1/16	2/32	2/32	2/32	2/32
1/4	18	0.459	1/8	1/8	2/32	2/32	2/32	2/32
3/8	18	0.454	1/8	1/8	2/32	2/32	2/32	2/32
1/2	14	0.579	1/4	1/8	2/32	1/16	2/32	2/32
3/4	14	0.565	1/4	1/8	2/32	1/16	2/32	2/32
1	11 1/2	0.678	3/8	3/16	2/32	1/16	2/32	2/32
1 1/4	11 1/2	0.686	3/8	3/16	2/32	1/16	2/32	2/32
1 1/2	11 1/2	0.699	3/8	3/16	2/32	1/16	2/32	2/32
2	11 1/2	0.667	3/8	3/16	2/32	1/16	2/32	2/32
2 1/2	8	0.925	3/2	1/2	4/64	1/16	2/32	2/32
3	8	0.925	3/2	1/2	4/64	1/16	2/32	2/32
3 1/2	8	0.938	1/2	1/2	4/64	1/16	2/32	2/32
4	8	0.950	1/2	1/2	4/64	1/16	2/32	2/32

<sup>a</sup>Distance that small end of tap projects through L1 taper ring gage (see ANSI B1.20.3).

All dimensions are given in inches.

**Lead Tolerance:** Plus or minus 0.003 inch per inch of cut thread and plus or minus 0.0005 inch per inch of ground thread.

**Angle Tolerance:** Plus or minus 40 min. in half angle and 60 min. in full angle for 8 cut threads per inch; plus or minus 45 min. in half angle and 68 min. in full angle for 11 1/2 to 27 cut threads per inch; plus or minus 25 min. in half angle for 8 ground threads per inch; and plus and minus 30 min. in half angle for 11 1/2 to 27 ground threads per inch.

**Table 9b. ANSI Standard Taper Pipe Thread — Widths of Flats at Tap Crests and Roots for Cut Thread NPT and Ground Thread NPT, ANPT, and NPTF**  
ASME/ANSI B94.9-1987

Threads per Inch	Tap Flat Width at	Column I NPT—Cut and Ground Thread ANPT—Ground Thread		Column II NPTF—Cut and Ground Thread	
		Minimum <sup>a</sup>	Maximum	Minimum <sup>a</sup>	Maximum
27	{ Major Diameter	0.0014	0.0041	0.0040	0.0055
	{ Minor Diameter	...	0.0041	...	0.0040
18	{ Major Diameter	0.0021	0.0057	0.0050	0.0065
	{ Minor Diameter	...	0.0057	...	0.0050
14	{ Major Diameter	0.0027	0.0064	0.0050	0.0065
	{ Minor Diameter	...	0.0064	...	0.0050
11½	{ Major Diameter	0.0033	0.0073	0.0050	0.0083
	{ Minor Diameter	...	0.0073	...	0.0060
8	{ Major Diameter	0.0048	0.0090	0.0080	0.0103
	{ Minor Diameter	...	0.0090	...	0.0080

<sup>a</sup>Minimum minor diameter flats are not specified. May be sharp as practicable.

All dimensions are given in inches.

Note: Cut Thread taps made to Column I are marked NPT but are not recommended for ANPT applications. Ground Thread taps made to Column I are marked NPT and may be used for NPT and ANPT applications. Ground Thread taps made to Column II are marked NPTF and used for Dryseal application.

**Table 10a. ANSI Standard Straight Pipe Taps (NPSF—Dryseal)—Ground Thread Limits** ASME/ANSI B94.9-1987

Nominal Size, Inches	Threads per Inch	Major Diameter		Pitch Diameter			Minor <sup>a</sup> Dia. Flat, Max.
		Min. G	Max. H	Plug at Gaging Notch E	Min. K	Max. L	
1/16	27	0.3008	0.3018	0.2812	0.2772	0.2777	0.004
1/8	27	0.3932	0.3942	0.3736	0.3696	0.3701	0.004
1/4	18	0.5239	0.5249	0.4915	0.4859	0.4864	0.005
3/8	18	0.6593	0.6603	0.6270	0.6213	0.6218	0.005
1/2	14	0.8230	0.8240	0.7784	0.7712	0.7717	0.005
3/4	14	1.0335	1.0345	0.9889	0.9817	0.9822	0.005

<sup>a</sup>As specified or sharper.

Nominal Size, Inches	Major Diameter		Pitch Diameter		Max. Minor Dia.
	Min. G	Max. H	Min. K	Max. L	
1/16	$H - 0.0010$	$K + Q - 0.0005$	$L - 0.0005$	$E - F$	$M - Q$
1/8	$H - 0.0010$	$K + Q - 0.0005$	$L - 0.0005$	$E - F$	$M - Q$
1/4	$H - 0.0010$	$K + Q - 0.0005$	$L - 0.0005$	$E - F$	$M - Q$
3/8	$H - 0.0010$	$K + Q - 0.0005$	$L - 0.0005$	$E - F$	$M - Q$
1/2	$H - 0.0010$	$K + Q - 0.0005$	$L - 0.0005$	$E - F$	$M - Q$
3/4	$H - 0.0010$	$K + Q - 0.0005$	$L - 0.0005$	$E - F$	$M - Q$

Values to Use in Formulas				
Threads per Inch	E	F	M	Q
27	Pitch diameter	0.0035		0.0251
18	of plug at	0.0052	Actual measured	0.0395
14	gaging notch	0.0067	pitch diameter	0.0533

All dimensions are given in inches.

Lead Tolerance: Plus or minus 0.0005 inch within any two threads not farther apart than one inch.

Angle Tolerance: Plus or minus 30 min. in half angle for 14 to 27 threads per inch.

**Table 10b. ANSI Standard Straight Pipe Taps (NPS)—Cut Thread Limits**  
ASME/ANSI B94.9-1987

Nominal Size	Threads per Inch, NPS, NPSC	Size at Gaging Notch	Pitch Diameter		Values to Use in Formulas		
			Min.	Max.	A	B	C
1/8	27	0.3736	0.3721	0.3751	0.0267	0.0296	0.0257
1/4	18	0.4916	0.4908	0.4938	} 0.0408	0.0444	0.0401
3/8	18	0.6270	0.6257	0.6292			
1/2	14	0.7784	0.7776	0.7811	} 0.0535	0.0571	0.0525
3/4	14	0.9889	0.9876	0.9916			
1	11 1/2	1.2386	1.2372	1.2412	0.0658	0.0696	0.0647

The following are approximate formulas, in which  $M$  = measured pitch diameter in inches:  
 Major dia., min. =  $M + A$   
 Major dia., max. =  $M + B$   
 Minor dia., max. =  $M - C$

All dimensions are given in inches.

*Lead Tolerance:* Plus or minus 0.003 inch per inch of thread.

*Angle Tolerance:* All pitches, plus or minus 45 min. in half angle and 68 min. in full angle. Taps made to these specifications are to be marked NPS and used for NPSC thread form.

**Table 10c. ANSI Standard Straight Pipe Taps (NPS)—Ground Thread Limits**  
ASME/ANSI B94.9-1987

Nominal Size, Inches	Threads per Inch, NPS, NPSC, NPSM	Major Diameter			Pitch Diameter		
		Plug at Gaging Notch	Min. $G$	Max. $H$	Plug at Gaging Notch $E$	Min. $K$	Max. $L$
1/8	27	0.3983	0.4022	0.4032	0.3736	0.3746	0.3751
1/4	18	0.5286	0.5347	0.5357	0.4916	0.4933	0.4938
3/8	18	0.6640	0.6701	0.6711	0.6270	0.6287	0.6292
1/2	14	0.8260	0.8347	0.8357	0.7784	0.7806	0.7811
3/4	14	1.0364	1.0447	1.0457	0.9889	0.9906	0.9916
1	11 1/2	1.2966	1.3062	1.3077	1.2386	1.2402	1.2412

Formulas for NPS Ground Thread Taps <sup>a</sup>						
Nominal Size	Major Diameter		Minor Dia.	Threads per Inch	A	B
	Min. $G$	Max. $H$	Max.			
1/8	$H - 0.0010$	$(K + A) - 0.0010$	$M - B$	27	0.0296	0.0257
1/4 to 3/4	$H - 0.0010$	$(K + A) - 0.0020$	$M - B$	18	0.0444	0.0401
	$H - 0.0015$	$(K + A) - 0.0021$	$M - B$	14	0.0571	0.0525
1	$H - 0.0015$	$(K + A) - 0.0021$	$M - B$	11 1/2	0.0696	0.0647

The maximum Pitch Diameter of tap is based upon an allowance deducted from the maximum product pitch diameter of NPSC or NPSM, whichever is smaller.  
 The minimum Pitch Diameter of tap is derived by subtracting the ground thread pitch diameter tolerance for actual equivalent size.

<sup>a</sup>In the formulas,  $M$  equals the actual measured pitch diameter.

All dimensions are given in inches.

*Lead tolerance:* Plus or minus 0.0005 inch within any two threads not farther apart than one inch.

*Angle Tolerance:* All pitches, plus or minus 30 min. in half angle. Taps made to these specifications are to be marked NPS and used for NPSC and NPSM.

Table 11a. ANSI Standard Ground Thread Straight Fluted Taps—Machine Screw Sizes ASME/ANSI B94.9-1987

Size	Basic Major Diameter	Threads per inch			No. of Flutes	Pitch Dia. Limits and Chamfers <sup>a</sup>				Length Overall A	Length of Thread	Length of Square	Diameter of Shank	E
		NC UNC	NF UNF	NS UNS		H1	H2	H3	H7					
0	0.060	...	80	...	2	TPB	PB	...	...	1 $\frac{1}{16}$	$\frac{3}{16}$	$\frac{3}{16}$	0.141	0.110
1	0.073	64	...	...	2	TPB	P	...	...	1 $\frac{1}{16}$	$\frac{3}{16}$	$\frac{3}{16}$	0.141	0.110
1	0.073	...	72	...	2	TPB	PB	...	...	1 $\frac{1}{16}$	$\frac{3}{16}$	$\frac{3}{16}$	0.141	0.110
2	0.086	56	...	...	2 <sup>b</sup>	...	PB	...	...	1 $\frac{1}{4}$	$\frac{3}{8}$	$\frac{3}{8}$	0.141	0.110
2	0.086	...	56	...	3	TPB	TPB	...	...	1 $\frac{1}{4}$	$\frac{3}{8}$	$\frac{3}{8}$	0.141	0.110
2	0.086	...	64	...	3	...	TPB	...	...	1 $\frac{1}{4}$	$\frac{3}{8}$	$\frac{3}{8}$	0.141	0.110
3	0.099	48	...	...	2 <sup>b</sup>	...	PB	...	...	1 $\frac{1}{8}$	$\frac{1}{2}$	$\frac{3}{8}$	0.141	0.110
3	0.099	48	...	...	3	P	TPB	...	...	1 $\frac{1}{8}$	$\frac{1}{2}$	$\frac{3}{8}$	0.141	0.110
3	0.099	...	56	...	3	...	TPB	...	...	1 $\frac{1}{8}$	$\frac{1}{2}$	$\frac{3}{8}$	0.141	0.110
4	0.112	...	...	36	3	...	TPB	...	...	1 $\frac{1}{8}$	$\frac{1}{2}$	$\frac{3}{8}$	0.141	0.110
4	0.112	40	...	...	2 <sup>b</sup>	P	PB	...	...	1 $\frac{1}{8}$	$\frac{1}{2}$	$\frac{3}{8}$	0.141	0.110
4	0.112	40	...	...	3	...	TPB	...	...	1 $\frac{1}{8}$	$\frac{1}{2}$	$\frac{3}{8}$	0.141	0.110
4	0.112	...	48	...	3	...	TPB	...	...	1 $\frac{1}{8}$	$\frac{1}{2}$	$\frac{3}{8}$	0.141	0.110
5	0.125	40	...	...	2 <sup>b</sup>	...	PB	...	...	1 $\frac{1}{16}$	$\frac{3}{8}$	$\frac{3}{8}$	0.141	0.110
5	0.125	40	...	...	3	P	TPB	...	...	1 $\frac{1}{16}$	$\frac{3}{8}$	$\frac{3}{8}$	0.141	0.110
5	0.125	...	44	...	3	...	TPB	...	...	1 $\frac{1}{16}$	$\frac{3}{8}$	$\frac{3}{8}$	0.141	0.110
6	0.138	32	...	...	2 <sup>b</sup>	P	PB	PB	...	2	$\frac{1}{16}$	$\frac{3}{8}$	0.141	0.110
6	0.138	32	...	...	3	TPB	TPB	TPB	PB	2	$\frac{1}{16}$	$\frac{3}{8}$	0.141	0.110
6	0.138	...	40	...	2 <sup>b</sup>	...	P	...	...	2	$\frac{1}{16}$	$\frac{3}{8}$	0.141	0.110
6	0.138	...	40	...	3	P	TPB	...	...	2	$\frac{1}{16}$	$\frac{3}{8}$	0.141	0.110
8	0.164	32	...	...	2 <sup>b</sup>	P	PB	PB	...	2 $\frac{1}{2}$	$\frac{3}{4}$	$\frac{1}{2}$	0.168	0.131
8	0.164	32	...	...	3 <sup>b</sup>	...	PB	PB	PB	2 $\frac{1}{2}$	$\frac{3}{4}$	$\frac{1}{2}$	0.168	0.131
8	0.164	32	...	...	4	TPB	TPB	TPB	PB	2 $\frac{1}{2}$	$\frac{3}{4}$	$\frac{1}{2}$	0.168	0.131
8	0.164	...	36	...	4	...	TPB	...	...	2 $\frac{1}{2}$	$\frac{3}{4}$	$\frac{1}{2}$	0.168	0.131
10	0.190	24	...	...	2 <sup>a</sup>	...	PB	PB	...	2 $\frac{3}{4}$	$\frac{3}{4}$	$\frac{1}{2}$	0.194	0.152
10	0.190	24	...	...	3 <sup>a</sup>	...	P	PB	...	2 $\frac{3}{4}$	$\frac{3}{4}$	$\frac{1}{2}$	0.194	0.152
10	0.190	...	32	...	2 <sup>b</sup>	P	PB	PB	...	2 $\frac{3}{4}$	$\frac{3}{4}$	$\frac{1}{2}$	0.194	0.152
10	0.190	...	32	...	3 <sup>b</sup>	...	PB	PB	PB	2 $\frac{3}{4}$	$\frac{3}{4}$	$\frac{1}{2}$	0.194	0.152
10	0.190	24	32	...	4	TPB	TPB	TPB	PB	2 $\frac{3}{4}$	$\frac{3}{4}$	$\frac{1}{2}$	0.194	0.152
12	0.216	24	...	...	4	...	...	...	...	2 $\frac{3}{4}$	$\frac{3}{4}$	$\frac{1}{2}$	0.220	0.165
12	0.216	...	28	...	4	...	...	...	...	2 $\frac{3}{4}$	$\frac{3}{4}$	$\frac{1}{2}$	0.220	0.165

<sup>a</sup>Chamfer designations are: T = taper, P = plug, and B = bottoming.

<sup>b</sup>Optional number of flutes.

All dimensions are given in inches.

These taps are standard as high-speed steel taps with ground threads, with standard and optional number of flutes and pitch diameter limits and chamfers as given in the table.

These are style 1 taps and have external centers on thread and shank ends (may be removed on thread end of bottoming taps).

For standard thread limits see Table 6. For eccentricity tolerances see Table 25.

Tolerances: Numbers 0 to 12 size range—A,  $\pm \frac{1}{32}$ ; B,  $\pm \frac{3}{64}$ ; C,  $\pm \frac{1}{32}$ ; D,  $-0.0015$ ; E,  $-0.004$ .

**Table 11b. ANSI Standard Cut Thread Straight Fluted Taps — Machine Screw Sizes**  
ASME/ANSI B94.9-1987

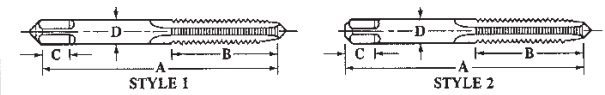

Size	Basic Major Diameter	Threads per Inch						Number of Flutes	Dimensions				
		Carbon Steel			HS Steel				Length Overall, A	Length of Thread, B	Length of Square, C	Diameter of Shank, D	Size of Square, E
		NC UNC	NF UNF	NS UNS	NC UNC	NF UNF							
0	0.660	...	80*	...	...	...	2	1 1/8	3/16	3/16	0.141	0.110	
1	0.673	64*	72*	...	...	...	2	1 1/16	3/8	3/16	0.141	0.110	
2	0.686	56	64*	...	...	...	3	1 1/8	3/16	3/16	0.141	0.110	
3	0.699	48*	56*	...	...	...	3	1 1/16	1/2	3/16	0.141	0.110	
4	0.112	40	48*	36*	40*	...	3	1 3/8	3/8	3/16	0.141	0.110	
5	0.125	40	...	...	40*	...	3	1 13/16	3/8	3/16	0.141	0.110	
6	0.138	32	40*	36*	32	...	3	2	1 1/16	3/16	0.141	0.110	
8	0.164	32	36*	40*	32	...	4	2 1/2	3/4	1/4	0.168	0.131	
10	0.190	24	32	...	24	32	4	2 3/8	3/4	1/4	0.194	0.152	
12	0.216	24	28*	...	24	...	4	2 3/8	15/16	3/8	0.220	0.165	
14	0.242	...	...	24*	...	...	4	2 1/2	1	3/16	0.255	0.191	

\*These taps are standard with plug chamfer only. All others are standard with taper, plug or bottoming chamfer.

Tolerances for General Dimensions					
Element	Range	Tolerance	Element	Range	Tolerance
Length Overall, A	0 to 14 incl	$\pm 0.002$	Diameter of Shank, D	0 to 12 incl	-0.004
Length of Thread, B	0 to 12 incl	$\pm 0.004$		14	-0.005
Length of Square, C	0 to 14 incl	$\pm 0.002$	Size of Square, E	0 to 14 incl	-0.004

All dimensions are given in inches.  
Styles 1 and 2 cut thread taps have optional style centers on thread and shank ends.  
For standard thread limits see Table 7. For eccentricity tolerances see Table 25.

**Table 12. ANSI Standard Nut Taps ASME/ANSI B94.9-1987**

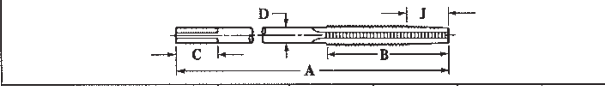

Dia. of Tap	Threads per inch NC,UNC	Number of Flutes	Length Overall, A	Length of Thread, B	Length of Square, C	Diameter of Shank, D	Size of Square, E
1/4	20	4	5	1 3/8	3/16	0.185	0.139
5/16	18	4	5 1/2	1 1/16	3/8	0.240	0.180
3/8	16	4	6	2	1 1/16	0.294	0.220
1/2	13	4	7	2 1/2	3/4	0.400	0.300

Tolerances for General Dimensions					
Element	Diameter Range	Tolerance	Element	Diameter Range	Tolerance
Overall Length, A	1/4 to 1/2	$\pm 0.002$	Shank Diameter, D	1/4 to 1/2	-0.005
Thread Length, B	1/4 to 1/2	$\pm 0.002$	Size of Square, E	1/4 to 1/2	-0.004
Square Length, C	1/4 to 1/2	$\pm 0.002$			

All dimensions are given in inches. These ground thread high-speed steel taps are standard in H3 limit only. All taps have an internal center in thread end. For standard limits see Table 4.  
Chamfer J is made 1/2 to 3/4 the thread length of B.

Table 13. ANSI Standard Spiral-Pointed Taps—Machine Screw Sizes  
ASME/ANSI B94.9-1987

**STYLE 1**

High-Speed Steel Taps with Ground Threads														
Size	Basic Major Diameter	Threads per Inch			No. of Flutes	Pitch Dia. Limits and Chamfers†				Length Overall, A	Length of Thread, B	Length of Square, C	Diameter of Shank, D	Size of Square, E
		NC UNC	NF UNF	NS UNS		H1	H2	H3	H7					
0	0.060	...	80	...	2	PB	PB	...	...	1 1/8	3/8	3/16	0.141	0.110
1	0.073	64	72	...	2	P	P	...	...	1 1/8	3/8	3/16	0.141	0.110
2	0.086	56	...	...	2	PB	PB	...	...	1 1/8	2/8	3/16	0.141	0.110
2	0.086	...	64	...	2	...	P	...	...	1 1/8	2/8	3/16	0.141	0.110
3	0.099	48	...	...	2	...	PB	...	...	1 1/8	1/2	3/16	0.141	0.110
3	0.099	...	56	...	2	P	P	...	...	1 1/8	1/2	3/16	0.141	0.110
4	0.112	...	...	36	2	...	P	...	...	1 1/8	3/8	3/16	0.141	0.110
4	0.112	40	...	...	2	P	PB	...	...	1 1/8	3/8	3/16	0.141	0.110
4	0.112	...	48	...	2	P	PB	...	...	1 1/8	3/8	3/16	0.141	0.110
5	0.125	40	...	...	2	P	PB	...	...	1 1/8	3/8	3/16	0.141	0.110
5	0.125	...	44	...	2	...	P	...	...	1 1/8	3/8	3/16	0.141	0.110
6	0.138	32	...	...	2	P	PB	PB	PB	2	1 1/8	3/16	0.141	0.110
6	0.138	...	40	...	2	...	PB	...	...	2	1 1/8	3/16	0.141	0.110
8	0.164	32	...	...	2	P	PB	PB	PB	2 1/8	3/8	1/4	0.168	0.131
8	0.164	...	36	...	2	...	P	...	...	2 1/8	3/8	1/4	0.168	0.131
10	0.190	24	...	...	2	P	PB	PB	P	2 3/8	3/8	1/4	0.194	0.152
10	0.190	...	32	...	2	PB	PB	PB	P	2 3/8	3/8	1/4	0.194	0.152
12	0.216	24	...	...	2	...	...	PB	...	2 3/8	1 1/8	3/16	0.220	0.165
12	0.216	...	28	...	2	...	...	P	...	2 3/8	1 1/8	3/16	0.220	0.165

High-Speed and Carbon Steel Taps with Cut Threads											
Size	Basic Major Diameter	Threads per Inch				No. of Flutes	Length Overall, A	Length of Thread, B	Length of Square, C	Diameter of Shank, D	Size of Square, E
		Carbon Steel		HS Steel							
		NC UNC	NF UNF	NC UNC	NF UNF						
4	0.112	...	...	40	...	2	1 1/8	3/8	3/16	0.141	0.110
5	0.125	...	...	40	...	2	1 1/8	3/8	3/16	0.141	0.110
6	0.138	32	...	32	...	2	2	1 1/8	3/16	0.141	0.110
8	0.164	32	...	32	...	2	2 1/8	3/8	1/4	0.168	0.131
10	0.190	24	...	32	32	2	2 3/8	3/8	1/4	0.194	0.152
12	0.216	...	...	24	...	2	2 3/8	1 1/8	3/16	0.220	0.165

Tolerances for General Dimensions							
Element	Size Range	Tolerance		Element	Size Range	Tolerance	
		Ground Thread	Cut Thread			Ground Thread	Cut Thread
Overall Length, A	0 to 12	±1/32	±1/32	Shank Diameter, D	0 to 12	-0.0015	-0.004
Thread Length, B	0 to 12	±3/64	±3/64	Size of Square, E	0 to 12	-0.004	-0.004
Square Length, C	0 to 12	±1/32	±1/32				

All dimensions are in inches. Chamfer designations are: P = plug and B = bottoming. Cut thread taps are standard with plug chamfer only. Style 1 ground thread taps have external centers on thread and shank ends (may be removed on thread end of bottoming taps). Style 1 cut thread taps have optional style centers on thread and shank ends. Standard thread limits for ground threads are given in Table 6 and for cut threads in Table 7. For eccentricity tolerances see Table 25.



Table 14. ANSI Standard Spiral Pointed Only and Regular and Fast Spiral-Fluted Taps — Machine Screw Sizes ASME/ANSI B94.9-1987

STYLE 1

Size	Basic Major Diameter	Threads per Inch		No. of Flutes	Pitch Dia. Limits & Chamfers <sup>a</sup>		Length Overall, A	Length of Thread, B	Length of Square, C	Diameter of Shank, D	Size of Square, E
		UNC	NF		H2	H3					
		UNC	UNF								
3 <sup>b</sup>	0.099	48	...	2	PB	...	1 <sup>15</sup> / <sub>16</sub>	1/2	3/16	0.141	0.110
4	0.112	40	...	2	PB	...	1 <sup>1</sup> / <sub>8</sub>	5/16	3/16	0.141	0.110
5	0.125	40	...	2	PB	...	1 <sup>3</sup> / <sub>16</sub>	5/16	3/16	0.141	0.110
6	0.138	32	...	2	...	PB	2	11/16	3/16	0.141	0.110
8	0.164	32	...	2 <sup>c</sup> , 3 <sup>b</sup>	...	PB	2 <sup>1</sup> / <sub>2</sub>	3/4	1/4	0.168	0.131
10	0.190	24	32	2 <sup>c</sup> , 3 <sup>b</sup>	...	PB	2 <sup>3</sup> / <sub>4</sub>	3/4	1/4	0.194	0.152
12 <sup>d</sup>	0.216	24	...	2 <sup>c</sup> , 3 <sup>b</sup>	...	PB	2 <sup>3</sup> / <sub>8</sub>	11/16	5/16	0.220	0.165

<sup>a</sup> Bottom chamfer applies only to regular and fast spiral-fluted machine screw taps.  
<sup>b</sup> Applies only to fast spiral-fluted machine screw taps.  
<sup>c</sup> Does not apply to fast spiral-fluted machine screw taps.  
<sup>d</sup> Does not apply to regular spiral-fluted machine screw taps.

Tolerances for General Dimensions					
Element	Size Range	Tolerance	Element	Size Range	Tolerance
Overall Length, A	3 to 12	±1/32	Shank Diameter, D	3 to 12	-0.0015
Thread Length, B	3 to 12	±1/64			
Square Length, C	3 to 12	±1/32	Size of Square, E	3 to 12	-0.004

All dimensions are given in inches. These standard taps are made of high-speed steel with ground threads. For standard thread limits see Table 6. For eccentricity tolerances see Table 25.

*Spiral Pointed Only Taps:* These taps are standard with plug chamfer only. They are provided with a spiral point only; the balance of the threaded section is left unfluted. These Style 1 taps have external centers on thread and shank ends.

*Regular Spiral Fluted Taps:* These taps have right-hand spiral flutes with a helix angle of from 25 to 35 degrees.

*Fast Spiral Fluted Taps:* These taps have right-hand spiral flutes with a helix angle of from 45 to 60 degrees.

Both regular and fast spiral-fluted Style 1 taps have external centers on thread and shank ends (may be removed on thread end of bottoming taps).

Chamfer designations: P = plug and B = bottoming.

Table 15a. ANSI Standard Ground Thread Straight Fluted Taps—  
Fractional Sizes ASME/ANSI B94.9-1987

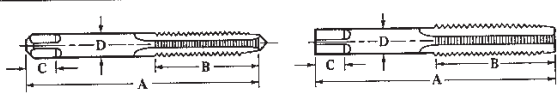

Dia. of Tap	Threads per Inch		No. of Flutes	Pitch Diameter Limits and Chamfers					Dimensions				
	NC UNC	NF UNF		H1	H2	H3	H4	H5	Length Overall, A	Length of Thread, B	Length of Square, C	Dia. of Shank, D	Size of Square, E
1/4	20	...	4	TPB	TPB	TPB	...	PB	2 1/2	1	3/16	0.255	0.191
1/4	...	28	4	PB	PB	TPB	PB	...	2 1/2	1	3/16	0.255	0.191
3/8	18	...	4	PB	PB	TPB	...	PB	2 5/8	1 1/8	3/8	0.318	0.238
3/8	...	24	4	PB	P	TPB	PB	...	2 5/8	1 1/8	3/8	0.318	0.238
1/2	16	...	4	PB	PB	TPB	...	PB	2 5/8	1 1/4	7/16	0.381	0.286
1/2	...	24	4	PB	PB	TPB	PB	...	2 5/8	1 1/4	7/16	0.381	0.286
5/8	14	20	4	...	...	TPB	...	PB	3 1/8	1 3/8	1/2	0.323	0.242
5/8	...	20	4	P	...	TPB	...	PB	3 1/8	1 3/8	1/2	0.367	0.275
3/4	13	...	4	P	...	TPB	...	P	3 3/8	1 3/4	5/8	0.367	0.275
3/4	...	20	4	PB	...	TPB	...	P	3 3/8	1 3/4	5/8	0.429	0.322
7/8	12	...	4	...	...	TPB	...	P	3 3/8	1 3/4	5/8	0.429	0.322
7/8	...	18	4	...	P	TPB	...	P	3 3/8	1 3/4	5/8	0.480	0.360
1	...	18	4	...	P	TPB	...	PB	3 3/8	1 3/4	5/8	0.480	0.360
1	...	11	4	...	P	TPB	...	PB	3 3/8	1 3/4	5/8	0.542	0.406
1	...	18	4	...	P	TPB	...	PB	3 3/8	1 3/4	5/8	0.590	0.442
1 1/8	...	10	4	...	P	TPB	...	PB	4 1/8	2	1 1/8	0.590	0.442
1 1/8	...	16	4	P	P	TPB	...	PB	4 1/8	2	1 1/8	0.697	0.523
1 1/8	...	9	4	...	...	TPB	...	TPB	4 3/8	2 1/8	3/4	0.697	0.523
1 1/8	...	14	4	...	P	TPB	...	TPB	4 3/8	2 1/8	3/4	0.800	0.600
1 1/2	...	8	4	...	...	TPB	...	TPB	5 1/8	2 1/2	7/8	0.800	0.600
1 1/2	...	12	4	...	...	TPB	...	TPB	5 1/8	2 1/2	7/8	0.800	0.600
1 1/2	...	12	4	...	...	TPB	...	TPB	5 1/8	2 1/2	7/8	0.896	0.672
1 3/4	...	7	12 <sup>d</sup>	4	...	...	TPB	...	5 3/8	2 3/8	1	1.021	0.766
1 3/4	...	6	12 <sup>d</sup>	4	...	...	TPB	...	6 1/8	3	1 1/8	1.108	0.831
1 3/4	...	6	12 <sup>d</sup>	4	...	...	TPB	...	6 3/8	3	1 1/8	1.233	0.925

<sup>a</sup>This size has 11 or 16 threads per inch NS-UNS.  
<sup>b</sup>These sizes are also available with plug chamfer in H6 pitch diameter limits.  
<sup>c</sup>This size has 14 threads per inch NS-UNS.  
<sup>d</sup>In these sizes NF-UNF thread taps have six flutes.

Tolerances for General Dimensions					
Element	Diameter Range	Tolerance	Element	Diameter Range	Tolerance
Length Overall, A	1/4 to 1 incl	±1/2	Diameter of Shank, D	1/4 to 3/8 incl	-0.0015
	1 1/8 to 1 1/2 incl	±1/16		3/8 to 1 1/2 incl	-0.002
Length of Thread, B	1/4 to 1/2 incl	±1/16	Size of Square, E	1/4 to 1/2 incl	-0.004
Length of Square, C	3/8 to 1 1/2 incl	±1/2		3/8 to 1 incl	-0.006
	1 1/8 to 1 1/2 incl	±1/16		1 1/4 to 1 1/2 incl	-0.008

All dimensions are given in inches.  
 These taps are standard in high-speed steel.  
 Chamfer designations are: T = taper, P = plug, and B = bottoming.  
 Style 2 taps, 3/8 inch and smaller, have external center on thread end (may be removed on bottoming taps) and external partial cone center on shank end with length of come approximately one-quarter of diameter of shank.  
 Style 3 taps, larger than 3/8 inch, have internal center in thread and shank ends.  
 For standard thread limits see Table 4. For eccentricity tolerances see Table 25.

Table 15b. ANSI Standard Cut Thread Straight Fluted Taps—  
Fractional Sizes ASME/ANSI B94.9-1987

Dia. of Tap	Threads Per Inch						No. of Flutes	Dimensions				
	Carbon Steel			HS Steel				Length Overall, A	Length of Thread, B	Length of Square, C	Dia. of Shank, D	Size of Square, E
	NC UNC	NF UNF	NS UNS	NC UNC	NF UNF							
1/8	...	...	40	...	...	3	1 1/16	3/8	3/16	0.141	0.110	
3/16	...	...	32	...	...	4	2 1/4	3/4	1/4	0.168	0.131	
1/4	...	...	24, 32	...	...	4	2 3/8	7/8	3/8	0.194	0.152	
5/16	20	28	...	20	28	4	2 1/2	1	5/16	0.255	0.191	
3/8	18	24	...	18	24	4	2 3/4	1 1/4	3/8	0.318	0.238	
7/16	16	24	...	16	24	4	2 7/8	1 1/2	7/16	0.381	0.286	
1/2	14	20	...	14	20	4	3 1/2	1 3/4	1/2	0.323	0.242	
5/8	13	20	...	13	20	4	3 3/4	1 7/8	5/8	0.367	0.275	
3/4	12	18	...	12	...	4	3 7/8	1 7/8	3/4	0.429	0.322	
7/8	11	18	...	11	18	4	3 7/8	1 7/8	7/8	0.480	0.360	
1	10	16	...	10	16	4	4 1/4	2	1	0.590	0.442	
1 1/8	9	14	...	9	14	4	4 1/2	2 1/4	1 1/8	0.697	0.523	
1 1/4	8	...	14 <sup>a</sup>	8	...	4	5 1/8	2 3/4	1 1/4	0.800	0.600	
1 1/2	7	12	...	...	...	4	5 3/8	2 3/4	1 1/2	0.896	0.672	
1 3/4	7	12 <sup>b</sup>	...	...	...	4	5 1/2	2 3/4	1	1.021	0.766	
2	6 <sup>a</sup>	12 <sup>b</sup>	...	...	...	4	6 1/8	3	1 3/4	1.108	0.831	
2 1/4	6	12 <sup>b</sup>	...	...	...	4	6 3/8	3	1 3/4	1.233	0.925	
2 1/2	5 <sup>a</sup>	...	...	...	...	6	7	3 3/8	1 3/2	1.430	1.072	
2 3/4	4 1/2 <sup>a</sup>	...	...	...	...	6	7 3/8	3 3/8	1 3/2	1.644	1.233	

<sup>a</sup>Standard in plug chamfer only.  
<sup>b</sup>In these sizes NF-UNF thread taps have six flutes.

Tolerances for General Dimensions					
Elements	Range	Tolerance	Elements	Range	Tolerance
Length Overall, A	1/16 to 1	±1/32	Diameter of Shank, D	1/16 to 3/16	-0.004
	1 1/8 to 2	±1/64		1/4 to 1	-0.005
Length of Thread, B	1/16 to 3/8	±1/64	Size of Square, E	1 1/8 to 2	-0.007
	1/4 to 1 1/2	±1/32		1/16 to 1/2	-0.004
Length of Square, C	1/16 to 1	±1/32	3/8 to 1	-0.006	
	1 1/8 to 2	±1/64	1/2 to 2	-0.008	

All dimensions are given in inches.  
These taps are standard in carbon steel and high-speed steel.  
Except where indicated, these taps are standard with taper, plug, or bottoming chamfer.  
Cut thread taps, sizes 3/8 inch and smaller have optional style center on thread and shank ends; sizes larger than 3/8 inch have internal centers in thread and shank ends.  
For standard thread limits see Table 3. For eccentricity tolerances see Table 25.

Table 16. ANSI Standard Straight Fluted (Optional Number of Flutes) and Spiral Pointed Taps—Fractional Sizes ASME/ANSI B94.9-1987

Dia. of Tap	Threads per Inch		No. of Flutes	Pitch Diameter Limits and Chamfers <sup>a,b</sup>					Length Overall, A	Length of Thread, B	Length of Square, C	Dia. of Shank, D	Size of Square, E
	UNC	UNF		H1	H2	H3	H4	H5					
Ground Thread High-Speed-Steel Straight Fluted Taps													
1/4	20	...	2	...	...	PB	...	...	2 1/2	1	5/16	0.255	0.191
1/4	20	...	3	P	P	PB	...	P	2 1/2	1	5/16	0.255	0.191
1/4	...	...	28	2,3	...	PB	...	...	2 1/2	1	5/16	0.255	0.191
3/16	18	...	2	...	...	PB	...	...	2 3/8	1 1/4	3/8	0.318	0.238
3/16	18	...	3	...	...	PB	...	...	2 3/8	1 1/4	3/8	0.318	0.238
3/16	...	...	24	3	...	PB	...	...	2 3/8	1 1/4	3/8	0.318	0.238
3/16	...	...	16	3	...	PB	...	...	2 3/8	1 1/4	3/8	0.318	0.238
3/16	...	...	24	3	...	PB	...	...	2 3/8	1 1/4	3/8	0.318	0.238
7/16	14	...	3	...	...	P	...	...	3 1/2	1 3/8	7/16	0.323	0.242
7/16	...	...	20	3	...	P	...	...	3 1/2	1 3/8	7/16	0.323	0.242
1/2	13	...	3	...	...	PB	...	...	3 3/4	1 3/2	7/8	0.367	0.275
1/2	...	...	20	3	...	P	...	...	3 3/4	1 3/2	7/8	0.367	0.275
Ground Thread High-Speed-Steel and Cut Thread High-Speed-Steel Spiral Pointed Taps													
1/4	20	...	2	P	P	PB	...	P	2 1/2	1	5/16	0.255	0.191
1/4	20	...	3	...	...	P	...	P	2 1/2	1	5/16	0.255	0.191
1/4	...	...	28	2	P	PB	...	P	2 1/2	1	5/16	0.255	0.191
1/4	...	...	28	3	...	P	...	P	2 1/2	1	5/16	0.255	0.191
3/16	18	...	2	P	P	PB	...	P	2 3/8	1 1/4	3/8	0.318	0.238
3/16	18	...	3	...	...	P	...	P	2 3/8	1 1/4	3/8	0.318	0.238
3/16	...	...	24	2	P	PB	...	P	2 3/8	1 1/4	3/8	0.318	0.238
3/16	...	...	24	3	...	P	...	P	2 3/8	1 1/4	3/8	0.318	0.238
3/16	...	...	16	3	...	P	...	P	2 3/8	1 1/4	3/8	0.318	0.238
3/16	...	...	24	3	...	P	...	P	2 3/8	1 1/4	3/8	0.318	0.238
7/16	14	...	3	...	...	P	...	P	3 1/2	1 3/8	7/16	0.323	0.242
7/16	...	...	20	3	...	P	...	P	3 1/2	1 3/8	7/16	0.323	0.242
1/2	13	20 <sup>c</sup>	3	P	P	P	...	P	3 3/4	1 3/2	7/8	0.367	0.275
1/2	...	...	11	18	3	...	...	pa	3 3/8	1 5/8	7/8	0.480	0.360
1/2	...	...	10	16	3	...	...	P	4 1/4	2	7/8	0.590	0.442

<sup>a</sup> Applies only to ground thread high-speed-steel taps.  
<sup>b</sup> Cut thread high-speed-steel taps are standard with plug chamfer only.  
<sup>c</sup> Applies only to 7/16-14 tap.  
<sup>d</sup> Applies only to 3/8-11 tap.  
<sup>e</sup> Applies only to 3/4-10 tap. For eccentricity tolerances see Table 25.

Element	Diameter Range	Tolerance		Element	Diameter Range	Tolerance	
		Ground Thread	Cut Thread			Ground Thread	Cut Thread
		Overall Length, A	±1/2			±1/2	Shank Diameter, D
Thread Length, B	±1/16	±1/16	Size of Square, E	3/8 to 3/4	-0.0040	-0.004	
				Square Length, C	1/4 to 1/2	±1/16	

All dimensions are given in inches. P = plug and B = bottoming. Ground thread taps—Style 2, 3/8 inch and smaller, have external center on thread end (may be removed on bottoming taps) and external partial cone center on shank end, with length of cone approximately 1/4 of shank diameter. Ground thread taps—Style 3, larger than 3/8 inch, have internal center in thread and shank ends. Cut thread taps, 3/8 inch and smaller have optional style center on thread and shank ends; sizes larger than 3/8 inch have internal centers in thread and shank ends. For standard thread limits see Tables 3 and 4.

Table 17. Other Types of ANSI Standard Taps ASME/ANSI B94.9-198

Dia. of Tap	Threads per Inch		Number of Flutes	Length Overall, A	Length of Thread, B	Length of Square, C	Dia. of Shank, D	Size of Square, E
	NC UNC	NF UNF						
1/4	20	28 <sup>a</sup>	2 <sup>b</sup> , 3 <sup>a</sup>	2 1/2	1	3/8	0.255	0.191
3/8	18	24 <sup>a</sup>	2 <sup>c</sup> , 3 <sup>a</sup>	2 3/8	1 1/8	1/2	0.318	0.238
1/2	16	24 <sup>a</sup>	3	2 1/2	1 1/2	5/8	0.381	0.286
5/8	14	20	3	3 1/2	1 3/4	3/4	0.523	0.242
1	13	20 <sup>d</sup>	3	3 3/4	1 3/4	7/8	0.567	0.275

<sup>a</sup> Does not apply to spiral pointed only taps.  
<sup>b</sup> Does not apply to spiral fluted taps or to spiral fluted taps with 28 threads per inch.  
<sup>c</sup> Applies only to spiral pointed only taps.  
<sup>d</sup> Applies only to fast spiral fluted taps.

Element	Diameter Range	Tolerance	Element	Diameter Range	Tolerance
Overall Length, A	1/4 to 1/2	±1/32	Shank Diameter, D	1/4 to 1/2	-0.0015
Thread Length, B	1/4 to 1/2	±1/16			
Square Length, C	1/4 to 1/2	±1/32	Size of Square, E	1/4 to 1/2	-0.004

All dimensions are given in inches. These standard taps are made of high-speed steel with ground threads. For standard thread limits see Table 4.

*Spiral Pointed Only Taps:* These taps are standard with plug chamfer only in H3 limit. They are provided with spiral point only. The balance of the threaded section is left unfluted.

*Spiral Fluted Taps:* These taps are standard with plug or bottoming chamfer in H3 limit and have right-hand spiral flutes with a helix angle of from 25 to 35 degrees.

*Fast Spiral Fluted Taps:* These taps are standard with plug or bottoming chamfer in H3 limit and have right-hand spiral flutes with a helix angle of from 45 to 60 degrees.

Style 2 taps, 3/8 inch and smaller, have external center on thread end (may be removed on bottoming taps) and external partial cone center on shank end with cone length approximately 1/4 shank diameter.

Style 3 taps larger than 3/8 inch have internal center in thread and shank ends.

For standard thread limits see Table 4. For eccentricity tolerances see Table 25.

Table 18. ANSI Standard Pulley Taps ASME/ANSI B94.9-1987

Dia. of Tap	Threads per Inch NC UNC	Number of Flutes	Length Overall, A	Length of Thread, B	Length of Square, C	Dia. of Shank, D	Length of Close Tolerance, T <sup>a</sup>	Size of Square, E	Length of Neck, K <sup>b</sup>
1/4	20	4	6,8	1	3/16	0.255	1 1/2	0.191	3/8
5/16	18	4	6,8	1 1/8	3/8	0.318	1 9/16	0.238	3/8
3/8	16	4	6,8,10	1 1/4	7/16	0.381	1 3/8	0.286	3/8
7/16	14	4	6	1 1/16	1/2	0.444	1 11/16	0.333	7/16
1/2	13	4	6,8,10,12	1 1/8	3/4	0.507	1 13/16	0.380	1/2
5/8	11	4	6,8,10	1 3/16	13/16	0.633	2	0.475	5/8
3/4	10	4	10	2	3/4	0.759	2 1/4	0.569	3/4

<sup>a</sup>T is minimum length of shank which is held to eccentricity tolerances.

<sup>b</sup>K neck optional with manufacturer.

Tolerances for General Dimensions					
Element	Diameter Range	Tolerance	Element	Diameter Range	Tolerance
Overall Length, A	1/4 to 3/4	±1/16	Shank Diameter, D	1/4 to 3/4	-0.005
Thread Length, B	1/4 to 3/4	±1/16			
Square Length, C	1/4 to 3/4	±1/32	Size of Square, E	1/2 to 1/2 3/8 to 3/4	-0.004 -0.006

All dimensions are given in inches. These ground thread high-speed steel taps are standard with plug chamfer in H3 limit only. All taps have an internal center in thread end. For standard thread limits see Table 4. For eccentricity tolerances see Table 25.

Table 19. ANSI Standard Ground Thread Spark Plug Taps—Metric Sizes ASME/ANSI B94.9-1987

Tap Diameter, mm	Pitch, mm	Number of Flutes	Overall Length, In. A	Thread Length, In. B	Square Length, In. C	Shank Dia., In. D	Square Size, In. E
14	1.25	4	3 13/32	1 21/32	1/2	0.429	0.322
18	1.50	4	4 1/2	1 13/16	5/8	0.542	0.406

These are high-speed steel Style 3 taps and have internal center in thread and shank ends. They are standard with plug chamfer only, right-hand threads with 60-degree form of thread.

Tolerances: Overall length, ±1/32 inch; thread length, ±1/32 inch; square length, ±1/32 inch; shank diameter, 14 mm, -0.0015 inch, 18 mm, -0.0020 inch; and size of square, -0.0040 inch.

Table 20a. ANSI Standard Ground Thread Straight Fluted Taps — M Profile — Metric Sizes ASME/ANSI B94.9-1987

Nom. Dia. mm.	Pitch mm.	No. of Flutes	Pitch Diameter Limits and Chamfers							Length Overall A	Length of Thread B	Length of Square C	Dia. of Square D	Size of Square E
			D3	D4	D5	D6	D7	D8	D9					
1.6	0.35	2	PB	...	...	...	...	...	1 1/4	5/16	3/16	0.141	0.110	
2	0.4	3	PB	...	...	...	...	...	1 1/4	5/16	3/16	0.141	0.110	
2.5	0.45	3	PB	...	...	...	...	...	1 1/4	1/2	3/16	0.141	0.110	
3	0.5	3	PB	...	...	...	...	...	1 1/4	5/8	3/16	0.141	0.110	
3.5	0.6	3	...	...	...	...	...	...	2	11/16	3/16	0.141	0.110	
4	0.7	4	...	...	...	...	...	...	2 1/4	3/4	1/4	0.168	0.131	
4.5	0.75	4	...	...	...	...	...	...	2 1/4	3/4	1/4	0.194	0.152	
5	0.8	4	...	...	...	...	...	...	2 1/4	7/8	1/4	0.194	0.152	
6	1	4	...	...	...	...	...	...	2 1/2	1	5/16	0.255	0.191	
7	1	4	...	...	...	...	...	...	2 3/4	1 1/4	3/8	0.318	0.238	
8	1.25	4	...	...	...	...	...	...	2 3/4	1 1/4	3/8	0.318	0.238	
10	1.5	4	...	...	...	...	...	...	2 3/4	1 1/2	7/16	0.381	0.286	
12	1.75	4	...	...	...	...	...	...	3 1/4	1 3/4	7/16	0.367	0.275	
14	2	4	...	...	...	...	...	...	3 3/4	1 3/4	1/2	0.429	0.322	
16	2	4	...	...	...	...	...	...	3 3/4	1 3/4	9/16	0.480	0.360	
20	2.5	4	...	...	...	...	...	...	4 1/2	2	1/2	0.652	0.489	
24	3	4	...	...	...	...	...	...	4 3/4	2 1/2	3/4	0.760	0.570	
30	3.5	4	...	...	...	...	...	...	5 1/4	2 3/4	1	1.021	0.766	
36	4	4	...	...	...	...	...	...	6 1/4	3	1 1/4	1.233	0.925	

Tolerances					
Element	Nom. Dia. Range, mm	Toler., Inch	Element	Nom. Dia. Range, mm	Toler., Inch
Overall Length, A	M1.6 to M24, incl.	±1/32	Shank Diameter, D	M1.6 to M14, incl.	-0.0015
	M30 and M36	±1/16			
Thread Length, B	M1.6 to M5, incl.	±1/64	Size of Square, E	M14 to M12, incl.	-0.004
	M6 to M12, incl.	±1/32			
Square Length, C	M1.6 to M24, incl.	±1/32		M14 to M24, incl.	-0.006
	M30 and M36	±1/16		M30 and M36	-0.008

All dimensions are in inches except where otherwise stated.  
 Chamfer Designation: P— Plug, B — Bottoming. These taps are high-speed steel.  
 Style 1 taps, sizes M1.6 through M5, have external center on thread and shank ends (may be removed on thread end of bottoming taps).  
 Style 2 taps, sizes M6, M7, M8, and M10, have external center on thread end (may be removed on bottoming taps) and external partial cone center on shank end with length of cone approximately 1/4 of diameter of shank.  
 Style 3 taps, sizes larger than M10 have external center on thread and shank ends.  
 For standard thread limits see Tables 8a and 8b.  
 For eccentricity tolerances of tap elements see Table 25.

Table 20b. ANSI Standard Spiral Pointed Ground Thread Taps — M Profile — Metric Sizes ASME/ANSI B94.9-1987

Nom. Dia. min.	Pitch min.	No. of Flutes	Pitch Diameter Limits and Styles					Length Overall	Length of Thread		Length of Square	Dia. of Square	Size of Square
			D3	D4	D5	D6	D7		A	B			
1.6	0.35	2	P	...	...	...	...	1 1/8	5/16	3/16	0.141	0.110	
2	0.4	2	P	...	...	...	...	1 1/4	3/8	3/16	0.141	0.110	
2.5	0.45	2	P	...	...	...	...	1 5/16	1/2	3/16	0.141	0.110	
3	0.5	2	P	...	...	...	...	1 3/8	5/8	3/16	0.141	0.110	
3.5	0.6	2	...	P	...	...	...	2	9/16	3/16	0.141	0.110	
4	0.7	2	...	P	...	...	...	2 1/8	3/4	1/4	0.168	0.131	
5	0.8	2	...	P	...	...	...	2 3/8	3/4	1/4	0.194	0.152	
6	1	2	...	P	...	...	...	2 1/2	1	5/16	0.255	0.191	
8	1.25	2	...	...	P	...	...	2 5/8	1 1/8	3/8	0.318	0.238	
10	1.5	3	...	...	P	...	...	2 7/8	1 1/4	7/16	0.381	0.286	
12	1.75	3	...	...	P	...	...	3 1/8	1 3/8	7/16	0.367	0.275	
14	2	3	...	...	P	...	...	3 5/8	1 7/8	1/2	0.429	0.322	
16	2	3	...	...	P	...	...	3 9/16	1 9/16	5/16	0.480	0.360	
20	2.5	3	...	...	P	...	...	4 5/8	2	11/16	0.652	0.489	

  

Tolerances					
Element	Nom. Dia. Range, mm	Toler., Inch	Element	Nom. Dia. Range, mm	Toler., Inch
Overall Length, A	M1.6 to M20, incl.	±1/32	Shank Diameter, D	M1.6 to M14, incl. M16 to M20	-0.0015 -0.002
Thread Length, B	M1.6 to M5, incl. M16 to M12, incl. M14 to M20	±1/64 ±1/16 ±3/32			
Square Length, C	M1.6 to M20	±1/32	Size of Square, E	M1.6 to M12, incl. M14 to M20, incl.	-0.004 -0.006

All dimensions are in inches except where otherwise stated.  
 Chamfer Designation: P — Plug. These taps are high-speed steel.  
 Style 1 taps, sizes M1.6 through M5, have external center on thread and shank ends.  
 Style 2 taps, sizes M6, M8 and M10, have external center on thread end and external partial cone center on shank end with length of cone approximately 1/4 of diameter of shank.  
 Style 3 taps, sizes larger than M10 have external center on thread and shank ends.  
 For standards thread limits see Table 8a and 8b.  
 For eccentricity tolerances of tap elements see Table 25.



Table 21. ANSI Standard Taper and Straight Pipe Taps ASME/ANSI B94.9-1987

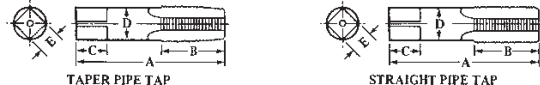

Nominal Size	Threads per Inch		Number of Flutes		Dimensions				
	Carbon Steel	High-Speed Steel	Regular	Interrupted	Length Overall, A	Length of Thread, B	Length of Square, C	Diameter of Shank, D	Size of Square, E
Taper Pipe Taps									
1/16"	...	27	4	...	2 1/4	1/8	3/16	0.3125	0.234
1/8"	27	27	4	5	2 1/4	3/8	3/8	0.3125	0.234
1/4"	27	27	4	5	2 1/4	3/4	3/8	0.4375	0.328
3/8"	18	18	4	5	2 5/8	1 1/8	7/16	0.5625	0.421
1/2"	18	18	4	5	2 5/8	1 3/8	1/2	0.7000	0.531
5/8"	14	14	4	5	3 1/4	1 7/8	3/4	0.6875	0.515
3/4"	14	14	5	5	3 1/4	1 3/4	3/4	0.9063	0.679
1"	11 1/2	11 1/2	5	5	3 3/4	1 3/4	1 1/8	1.1250	0.843
1 1/4"	11 1/2	11 1/2	5	5	4	1 3/4	1 1/8	1.3125	0.984
1 1/2"	11 1/2	11 1/2	7	7 <sup>a</sup>	4 1/2	1 3/4	1	1.5000	1.125
2"	11 1/2	11 1/2	7	7 <sup>a</sup>	4 1/2	1 3/4	1 1/4	1.8750	1.406
2 1/2" <sup>c</sup>	8	...	8	...	5 1/2	2 3/8	1 1/4	2.2500	1.687
3" <sup>c</sup>	8	...	8	...	6	2 3/4	1 1/4	2.6250	1.968
Straight Pipe Taps									
1/16"	...	27	4	...	2 1/4	3/8	3/8	0.3125	0.234
1/8"	...	27	4	...	2 1/4	3/4	3/8	0.4375	0.328
1/4"	...	18	4	...	2 5/8	1 1/8	7/16	0.5625	0.421
3/8"	...	18	4	...	2 5/8	1 3/8	1/2	0.7000	0.531
1/2"	...	14	4	...	3 1/4	1 3/4	3/4	0.6875	0.515
3/4"	...	14	5	...	3 1/4	1 3/4	3/4	0.9063	0.679
1"	...	11 1/2	5	...	3 3/4	1 3/4	1 1/8	1.1250	0.843

<sup>a</sup> Ground thread taps only.

<sup>b</sup> Standard in NPT form of thread only.

<sup>c</sup> Cut thread taps only.

Tolerances for General Dimensions							
Element	Diameter Range	Tolerance		Element	Diameter Range	Tolerance	
		Cut Thread	Ground Thread			Cut Thread	Ground Thread
Overall Length, A	1/16 to 3/4	±1/32	±1/16	Shank Diameter, D	1/8 to 1/2	...	-0.0015
Thread Length, B	1 to 3	±1/16	±1/16		1/4 to 1	-0.007	...
	1/8 to 3/4	±1/16	±1/16		1/2 to 1	...	-0.002
Square Length, C	1 to 1 1/4	±1/16	±1/16	3/4 to 3	-0.009	...	
	1 1/2 to 3	±1/8	±1/8	1 1/4 to 2	...	-0.003	
Size of Square, E	1/8 to 3/4	±1/16	±1/16	Size of Square, E	1/8 to 1/4	-0.004	-0.004
	1 to 3	±1/8	±1/8		1/2 to 3/4	-0.006	-0.006
						1 to 3	-0.008

All dimensions are given in inches. These taps have an internal center in the thread end. *Taper Pipe Threads:* The 1/8-inch pipe tap is furnished with large size shank unless the small shank is specified. These taps have 2 to 3 1/2 threads chamfer. The first few threads on interrupted thread pipe taps are left full. The following styles and sizes are standard: 1/16 to 2 inches regular ground thread, NPT, NPTF, and ANPT; 1/8 to 2 inches interrupted ground thread, NPT, NPTF and ANPT; 1/8 to 3 inches carbon steel regular cut thread, NPT; 1/8 to 2 inches high-speed steel, regular cut thread, NPT; 1/8 to 1 1/4 inches high-speed steel interrupted cut thread, NPT. For standard thread limits see Tables 9a and 9b. *Straight Pipe Threads:* The 1/8-inch pipe tap is furnished with large size shank unless the small size is specified. These taps are standard with plug chamfer only. The following styles and sizes are standard: ground threads — 1/8 to 1 inch, NPSC and NPSM; 1/8 to 3/4 inch, NPSF; cut threads — 1/8 to 1 inch, NPSC and NPSM. For standard thread limits see Tables 10a, 10b, and 10c. For eccentricity tolerances see Table 25.

**Table 22. Taps Recommended for Classes 2B and 3B Unified Screw Threads—  
Numbered and Fractional Sizes ASME/ANSI B94.9-1987**

Size	Threads per Inch		Recommended Tap For Class of Thread		Pitch Diameter Limits For Class of Thread		
	NC UNC	NF UNF	Class 2B <sup>a</sup>	Class 3B	Min All Classes (Basic)	Max Class 2B	Max Class 3B
Machine Screw Numbered Size Taps							
0	...	80	G H2	G H1	0.0519	0.0542	0.0536
1	64	...	G H2	G H1	0.0629	0.0655	0.0648
1	...	72	G H2	G H1	0.0640	0.0665	0.0659
2	56	...	G H2	G H1	0.0744	0.0772	0.0765
2	...	64	G H2	G H1	0.0759	0.0786	0.0779
3	48	...	G H2	G H1	0.0855	0.0885	0.0877
3	...	56	G H2	G H1	0.0874	0.0902	0.0895
4	40	...	G H2	G H2	0.0958	0.0991	0.0982
4	...	48	G H2	G H1	0.0985	0.1016	0.1008
5	40	...	G H2	G H2	0.1088	0.1121	0.1113
5	...	44	G H2	G H1	0.1102	0.1134	0.1126
6	32	...	G H3	G H2	0.1177	0.1214	0.1204
6	...	40	G H2	G H2	0.1218	0.1252	0.1243
8	32	...	G H3	G H2	0.1437	0.1475	0.1465
8	...	36	G H2	G H2	0.1460	0.1496	0.1487
10	24	...	G H3	G H3	0.1629	0.1672	0.1661
10	...	32	G H3	G H2	0.1697	0.1736	0.1726
12	24	...	G H3	G H3	0.1889	0.1933	0.1922
12	...	28	G H3	G H3	0.1928	0.1970	0.1959
Fractional Size Taps							
1/4	20	...	G H5	G H3	0.2175	0.2224	0.2211
1/4	...	28	G H4	G H3	0.2268	0.2311	0.2300
3/16	18	...	G H5	G H3	0.2764	0.2817	0.2803
3/16	...	24	G H4	G H3	0.2854	0.2902	0.2890
5/16	16	...	G H5	G H3	0.3344	0.3401	0.3387
5/16	...	24	G H4	G H3	0.3479	0.3528	0.3516
3/8	14	...	G H5	G H3	0.3911	0.3972	0.3957
3/8	...	20	G H5	G H3	0.4050	0.4104	0.4091
7/16	13	...	G H5	G H3	0.4500	0.4565	0.4548
7/16	...	20	G H5	G H3	0.4675	0.4731	0.4717
1/2	12	...	G H5	G H3	0.5084	0.5152	0.5135
1/2	...	18	G H5	G H3	0.5264	0.5323	0.5308
5/8	11	...	G H5	G H3	0.5660	0.5732	0.5714
5/8	...	18	G H5	G H3	0.5889	0.5949	0.5934
3/4	10	...	G H5	G H5	0.6850	0.6927	0.6907
3/4	...	16	G H5	G H3	0.7094	0.7159	0.7143
7/8	9	...	G H6 <sup>b</sup>	G H4	0.8028	0.8110	0.8089
7/8	...	14	G H6 <sup>b</sup>	G H4	0.8286	0.8356	0.8339
1	8	...	G H6 <sup>b</sup>	G H4	0.9188	0.9276	0.9254
1	...	12	G H6 <sup>b</sup>	G H4	0.9459	0.9535	0.9516
1	...	14NS	G H6 <sup>b</sup>	G H4	0.9536	0.9609	0.9590
1 1/4	7	...	G H8 <sup>b</sup>	G H4	1.0322	1.0416	1.0393
1 1/4	...	12	G H6 <sup>b</sup>	G H4	1.0709	1.0787	1.0768
1 1/2	7	...	G H8 <sup>b</sup>	G H4	1.1572	1.1668	1.1644
1 1/2	...	12	G H6 <sup>b</sup>	G H4	1.1959	1.2039	1.2019
1 3/4	6	...	G H8 <sup>b</sup>	G H4	1.2667	1.2771	1.2745
1 3/4	...	12	G H6 <sup>b</sup>	G H4	1.3209	1.3291	1.3270
1 3/4	...	6	G H8 <sup>b</sup>	G H4	1.3917	1.4022	1.3996
1 3/4	...	12	G H6 <sup>b</sup>	G H4	1.4459	1.4542	1.4522

<sup>a</sup>Cut thread taps in all fractional sizes and in numbered sizes 3 to 12 NC and NF may be used under normal conditions and in average materials to produce tapped holes in this classification.

<sup>b</sup>Standard G H4 taps are also suitable for this class of thread.

All dimensions are given in inches.

The above recommended taps normally produce the class of thread indicated in average materials when used with reasonable care. However, if the tap specified does not give a satisfactory gage fit in the work, a choice of some other limit tap will be necessary.

**Standard System of Tap Marking.**—Ground thread taps, inch screw threads, are marked with the nominal size, number of threads per inch, the proper symbol to identify the thread form, “HS” for high-speed steel, “G” for ground thread, and designators for tap pitch diameter and special features, such as left-hand and multi-start threads.

Cut thread taps, inch screw threads, are marked with the nominal size, number of threads per inch, and the proper symbol to identify the thread form. High-speed steel taps are marked “HSS,” but carbon steel taps need not be marked.

Ground thread taps made with metric screw threads, M profile, are marked with “M,” followed by the nominal size and pitch in millimeters, separated by “x.” Marking also includes “HS” for high-speed steel, “G” for ground thread, designators for tap pitch diameter and special features, such as left-hand and multi-start threads.

Thread symbol designators are listed in the accompanying table. Tap pitch diameter designators, systems of limits, special features, and examples for ground threads are given in the following section.

**Standard System Tap Thread Limits and Identification for Unified Inch Screw Threads, Ground Thread.**—*H or L Limits:* For Unified inch screw threads, when the maximum tap pitch diameter is over basic pitch diameter by an even multiple of 0.0005 in. or the minimum tap pitch diameter limit is under basic pitch diameter by an even multiple of 0.0005 in., the taps are marked “H” or “L,” respectively, followed by a limit number, determined as follows:

H limit number = Amount maximum tap PD limit is over basic PD divided by 0.0005

L limit number = Amount minimum tap PD limit is under basic PD divided by 0.0005

Table 23. Thread Series Designations

Standard Tap Marking	Product Thread Designation	Third Series
M	M	Metric Screw Threads—M Profile, with basic ISO 68 profile
M	MJ	Metric Screw Threads—M Profile, with rounded root of radius 0.15011P to 0.18042P Class 5 interference-fit thread
NC	NC <sub>1</sub> IF	Entire ferrous material range
NC	NC <sub>1</sub> INF	Entire nonferrous material range
NPS	NPSC	American Standard straight pipe threads in pipe couplings
NPSF	NPSF	Dry seal American Standard fuel internal straight pipe threads
NPSH	NPSH	American Standard straight hose coupling threads for joining to American Standard taper pipe threads
NPS1	NPS1	Dryseal American Standard intermediate internal straight pipe threads
NPSL	NPSL	American Standard straight pipe threads for loose-fitting mechanical joints with locknuts
NPS	NPSM	American Standard straight pipe threads for free-fitting mechanical joints for fixtures
NPT	NPT	American Standard taper pipe threads for general use
NPTF	NPTF	Dryseal American Standard taper pipe threads
NPTR	NPTR	American Standard taper pipe threads for railing joints
<b>Unified Inch Screw Thread</b>		
N	UN	Constant-pitch series
NC	UNC	Coarse pitch series
NF	UNF	Fine pitch series
NEF	UNEF	Extra-fine pitch series
N	UN1	Constant-pitch series, with rounded root of radius 0.15011P to 0.18042P (ext. thd. only)
NC	UN1C	Coarse pitch series, with rounded root of radius 0.15011P to 0.18042P (ext. thd. only)
NF	UN1F	Fine pitch series, with rounded root of radius 0.15011P to 0.18042P (ext. thd. only)
NEF	UN1EF	Extra-fine pitch series, with rounded root of radius 0.15011P to 0.18042P (ext. thd. only)
N	UNR	Constant-pitch series, with rounded root of radius not less than 0.108P (ext. thd. only)
NC	UNRC	Coarse thread series, with rounded root of radius not less than 0.108P (ext. thd. only)
NF	UNRF	Fine pitch series, with rounded root of radius not less than 0.108P (ext. thd. only)
NEF	UNREF	Extra-fine pitch series, with rounded root of radius not less than 0.108P (ext. thd. only)
NS	UNS	Special diameter pitch, or length of engagement

The PD limits for various H limit numbers are given in Table 4. The PD limits for L limit numbers are determined as follows. The minimum tap PD equals the basic PD minus the number of half-thousandths (0.0005 in.) represented by the limit number. The maximum tap PD equals the minimum PD plus the PD tolerance given in Table 24.

**Table 24. PD Tolerance for Unified Inch Screw Threads—  
Ground Thread ASME/ANSI B94.9-1987**

Threads per Inch	To 1 in., incl.	Over 1 in. to 1½ in., incl.	Over 1½ to 2½ in., incl.	Over 2½ in.
80-28	0.0005	0.0010	0.0010	0.0015
24-18	0.0005	0.0010	0.0015	0.0015
16-18	0.0005	0.0010	0.0015	0.0020
7-6	0.0010	0.0010	0.0020	0.0025
5½-4	0.0010	0.0015	0.0020	0.0025

Examples: ⅜-16 NC HS H1

Max. tap PD = 0.3349

Min. tap PD = 0.3344

⅜-16 NC HS G L2

Min. tap PD = Basic PD - 0.0010 in. = 0.3344 - 0.0010 = 0.3334

Max. tap PD = Min. Tap PD + 0.0005 = 0.3334 + 0.0005 = 0.3339

*Oversize or Undersize:* When the maximum tap PD over basic PD or the minimum tap PD under basic PD is not an even multiple of 0.0005, the tap PD is usually designated as an amount oversize or undersize. The amount oversize is added to the basic PD to establish the *minimum* tap PD. The amount undersize is subtracted from the basic PD to establish the *minimum* tap PD. The PD tolerance in Table 24 is added to the minimum tap PD to establish the maximum tap PD for both.

Example: ⅜-14 NC plus 0.0017 HS G

Min. tap PD = Basic PD + 0.0017 in.

Max. tap PD = Min. tap PD + 0.0005 in.

Whenever possible for oversize or other special tap PD requirements, the maximum and minimum tap PD requirements should be specified.

*Special Tap Pitch Diameter:* Taps not made to H or L limit numbers, to Table 25, or to the formula for oversize or undersize taps, may be marked with the letter "S" enclosed by a circle or by some other special identifier. Example: ½-16 NC HS G.

**Table 25. ANSI Standard Eccentricity Tolerances of Tap Elements When Tested on Dead Centers ASME/ANSI B94.9-1987**

Element	Range Sizes are Inclusive			Cut Thread		Ground Thread	
	Hand, Mch. Screw	Metric	Pipe	Eccentricity	tiv <sup>a</sup>	Eccentricity	tiv <sup>a</sup>
Square (at central point)	#0-½"	M1.6-M12	½"-½"	0.0030	0.0060	0.0030	0.0060
	½"-4"	M14-M100	¼"-4"	0.0040	0.0080	0.0040	0.0080
Shank	#0-⅜"	M1.6-M8	⅜"	0.0030	0.0060	0.0005	0.0010
	⅜"-4"	M10-M100	¼"-4"	0.0040	0.0080	0.0008	0.0016
Major Diameter	#0-⅜"	M1.6-M8	⅜"	0.0025	0.0050	0.0005	0.0010
	⅜"-4"	M10-M100	¼"-4"	0.0040	0.0080	0.0008	0.0016
Pitch Diameter (at first full thread)	#0-⅜"	M1.6-M8	⅜"	0.0025	0.0050	0.0005	0.0010
	⅜"-4"	M10-M100	¼"-4"	0.0040	0.0080	0.0008	0.0016
Chamfer <sup>b</sup>	#0-½"	M1.6-M12	½"-½"	0.0020	0.0040	0.0010	0.0020
	½"-4"	M14-M100	¼"-4"	0.0030	0.0060	0.0015	0.0030

<sup>a</sup>tiv = total indicator variation. Figures are given for both eccentricity and total indicator variation to avoid misunderstanding.

<sup>b</sup>Chamfer should preferably be inspected by light projection to avoid errors due to indicator contact points dropping into the thread groove.

All dimensions are given in inches.

*Left-Hand Taps:* Taps with left-hand threads are marked "LEFT HAND" or "LH."  
*Example:*  $\frac{3}{8}$ -16 NC LH HS G H3.

*Multiple-Start Threads:* Taps with multiple-start threads are marked with the lead designated as a fraction, also "Double," "Triple," etc. The Unified Screw Thread form symbol is always designated as "NS" for multiple-start threads. *Example:*  $\frac{3}{8}$ -16 NS Double  $\frac{1}{8}$  Lead HS G H5.

**Standard System of Ground Thread Tap Limits and Identification for Metric Screw Threads—M Profile.**—All calculations for metric taps use millimeter values. When U.S. customary values are needed, they are translated from the three-place millimeter tap diameters only after the calculations are completed.

**Table 26. PD Tolerance for Metric Screw Threads—  
 M Profile—Ground Threads ASME/ANSI B94.9-1987**

Pitch, <i>P</i> (mm)	M1.6 to M6.3, incl.	Over M6.3 to M25, incl.	Over M25 to M90, incl.	Over M90
0.3	0.015	0.015	0.020	0.020
0.35	0.015	0.015	0.020	0.020
0.4	0.015	0.015	0.020	0.025
0.45	0.015	0.020	0.020	0.025
0.5	0.015	0.020	0.025	0.025
0.6	0.020	0.020	0.025	0.025
0.7	0.020	0.020	0.025	0.025
0.75	0.020	0.025	0.025	0.031
0.8	0.020	0.025	0.025	0.031
0.9	0.020	0.025	0.025	0.031
1	0.025	0.025	0.031	0.031
1.25	0.025	0.031	0.031	0.041
1.5	0.025	0.031	0.031	0.041
1.75	...	0.031	0.041	0.041
2	...	0.041	0.041	0.041
2.5	...	0.041	0.041	0.052
3	...	0.041	0.052	0.052
3.5	...	0.041	0.052	0.052
4	...	0.052	0.052	0.064
4.5	...	0.052	0.052	0.064
5	...	...	0.064	0.064
5.5	...	...	0.064	0.064
6	...	...	0.064	0.064

*D or DU Limits:* When the maximum tap pitch diameter is over basic pitch diameter by an even multiple of 0.013 mm (0.000512 in. reference), or the minimum tap pitch diameter limit is under basic pitch diameter by an even multiple of 0.013 mm, the taps are marked with the letters "D" or "DU," respectively, followed by a limit number. The limit number is determined as follows:

D limit number = Amount maximum tap PD limit is over basic PD divided by 0.013

DU limit number = Amount minimum tap PD limit is under basic PD divided by 0.013

The PD limits for various D limit numbers are given in Table 5b. The PD limits for DU limit numbers are determined as follows. The minimum tap PD equals the basic PD minus the number of millimeters represented by the limit number (multiples of 0.013 mm). The maximum tap PD equals the minimum tap PD plus the PD tolerance given in Table 26. E

Table 27. Dimensions of Acme Threads Taps in Sets of Three Taps

Nominal Dia.	A	B	C	D	E	F	G	H	I	K
1/8	4 1/4	1 3/8	2 3/8	1/2	1 3/8	3/8	1 3/4	7/8	1 1/2	0.520
3/16	4 7/8	2 1/8	2 3/4	5/16	2 1/8	3/4	2	1	1 3/4	0.582
1/4	5 1/2	2 3/8	3 1/4	3/8	2 1/2	3/8	2 1/4	1 1/4	2	0.645
5/16	6	2 1/2	3 1/2	3 3/16	2 1/8	1/2	2 3/8	1 1/4	2 1/4	0.707
3/8	6 1/2	2 11/16	3 11/16	1/2	3 1/4	1	2 11/16	1 3/8	2 11/16	0.770
1/2	6 5/8	2 3/4	4 1/8	3/4	3 5/8	1 1/8	3	1 3/8	2 5/8	0.832
5/8	7 1/4	3	4 1/4	3/4	3 3/4	1 1/4	3 1/8	1 1/2	2 3/4	0.895
3/4	7 5/8	3 1/8	4 7/8	7/8	3 7/8	1 3/8	3 1/2	1 3/8	2 7/8	0.957
1	7 3/4	3 1/4	4 3/4	1 1/16	3 3/4	1 1/2	3 3/8	1 5/8	3	1.020
1 1/8	8 1/4	3 5/8	4 5/8	7/8	4 1/8	1 5/8	3 5/8	1 3/4	3 3/8	1.145
1 1/4	9	3 3/4	5 1/4	1 1/16	4 3/8	1 3/4	3 3/8	1 3/8	3 3/8	1.270
1 1/2	9 1/2	4	5 1/2	1	4 1/2	1 7/8	4 1/8	2	3 1/2	1.395
1 3/4	10	4 1/4	5 3/4	1	4 3/4	1 1/2	4 1/4	2 1/8	3 5/8	1.520
1 7/8	10 1/2	4 1/2	6	1	5	1 1/2	4 1/2	2 1/8	3 3/4	1.645
2	11	4 3/4	6 1/4	1 1/16	5 1/8	1 3/4	4 1/2	2 1/4	4	1.770
2 1/8	11 1/4	4 3/4	6 1/2	1 1/16	5 1/8	1 3/4	4 1/2	2 1/4	4 1/4	1.895
2 1/4	11 3/4	5	6 3/4	1 1/8	5 3/8	1 5/8	5 1/8	2 3/8	4 3/8	2.020
2 1/2	12 1/4	5 1/4	7 1/4	1 1/8	6 1/4	1 3/4	5 1/2	2 1/2	4 3/4	2.270
2 3/4	13 1/4	5 1/2	7 3/4	1 1/4	6 3/8	1 5/8	5 3/8	2 3/8	5 1/8	2.520
3	14	5 3/4	8 1/4	1 1/4	7	2	6 1/4	2 3/4	5 1/2	2.770
3 1/2	15	6 1/4	8 3/4	1 1/4	7 1/2	2	6 3/4	3	5 3/4	3.020

Examples:

M1.6 x 0.35 HS G D3

Max. tap PD = 1.412

Min. tap PD = 1.397

M6 x 1 HS G DU4

Min. tap PD = Basic PD - 0.052 mm = 5.350 - 0.052 = 5.298

Max. tap PD = Min. tap PD + 0.025 mm = 5.323

Metric oversize or undersize taps, taps with special pitch diameters, and left-hand taps follow the marking system given for inch taps.

*Examples:*

M12 × 1.75 + 0.044 HS G

M10 × 1.5 HS G

M10 × 1.5 LH HS G D6

*Multiple-Start Threads:* Metric taps with multiple-start threads are marked with the lead designated in millimeters preceded by the letter "L," the pitch in millimeters preceded by the letter "P," and the words "(2 starts)," "(3 starts)," etc.

*Examples:* M16 × L4-P2 (2 starts) HS G D8

M14 × L6-P2 (3 starts) HS G D7

**Acme and Square-Threaded Taps.**—These taps are usually made in sets, three taps in a set being the most common. For very fine pitches, two taps in a set will be found sufficient, whereas as many as five taps in a set are used for coarse pitches. The table on the next page gives dimensions for proportioning both Acme and square-threaded taps when made in sets. In cutting the threads of square-threaded taps, one leading tap maker uses the following rules: The width of the groove between two threads is made equal to one-half the pitch of the thread, less 0.004 inch, making the width of the thread itself equal to one-half of the pitch, plus 0.004 inch. The depth of the thread is made equal to 0.45 times the pitch, plus 0.0025 inch. This latter rule produces a thread that for all the ordinarily used pitches for square-threaded taps has a depth less than the generally accepted standard depth, this latter depth being equal to one-half the pitch. The object of this shallow thread is to ensure that if the hole to be threaded by the tap is not bored out so as to provide clearance at the bottom of the thread, the tap will cut its own clearance. The hole should, however, always be drilled out large enough so that the cutting of the clearance is not required of the tap.

The table, *Dimensions of Acme Threads Taps in Sets of Three Taps*, may also be used for the length dimensions for Acme taps. The dimensions in this table apply to single-threaded taps. For multiple-threaded taps or taps with very coarse pitch, relative to the diameter, the length of the chamfered part of the thread may be increased. Square-threaded taps are made to the same table as Acme taps, with the exception of the figures in column *K*, which for square-threaded taps should be equal to the nominal diameter of the tap, no oversize allowance being customary in these taps. The first tap in a set of Acme taps (not square-threaded taps) should be turned to a taper at the bottom of the thread for a distance of about one-quarter of the length of the threaded part. The taper should be so selected that the root diameter is about  $\frac{1}{32}$  inch smaller at the point than the proper root diameter of the tap. The first tap should preferably be provided with a short pilot at the point. For very coarse pitches, the first tap may be provided with spiral flutes at right angles to the angle of the thread. Acme and square-threaded taps should be relieved or backed off on the top of the thread of the chamfered portion on all the taps in the set. When the taps are used as machine taps, rather than as hand taps, they should be relieved in the angle of the thread, as well as on the top, for the whole length of the chamfered portion. Acme taps should also always be relieved on the front side of the thread to within  $\frac{1}{32}$  inch of the cutting edge.

*Adjustable Taps:* Many adjustable taps are now used, especially for accurate work. Some taps of this class are made of a solid piece of tool steel that is split and provided with means of expanding sufficiently to compensate for wear. Most of the larger adjustable taps have inserted blades or chasers that are held rigidly, but are capable of radial adjustment. The use of taps of this general class enables standard sizes to be maintained readily.

Table 28. Proportions of Acme and Square-Threaded Taps Made in Sets

$R = 0.010''$

$R = \text{root diameter of thread.}$   
 $T = \text{double depth of full thread.}$   
 $D = \text{full diameter of tap.}$

Kind of Tap	No. of Taps in Set	Order of Tap in Set	A	B	C
Acme-Thread Taps	2	1st	$R + 0.65T$	$R + 0.010$	$\frac{1}{8}L \text{ to } \frac{1}{16}L$
		2d	$D$	A on 1st tap - 0.005	$\frac{1}{4}L \text{ to } \frac{1}{2}L$
	3	1st	$R + 0.45T$	$R + 0.010$	$\frac{1}{8}L \text{ to } \frac{1}{16}L$
		2d	$R + 0.80T$	A on 1st tap - 0.005	$\frac{1}{8}L \text{ to } \frac{1}{4}L$
		3d	$D$	A on 2d tap - 0.005	$\frac{1}{4}L \text{ to } \frac{1}{2}L$
	4	1st	$R + 0.40T$	$R + 0.010$	$\frac{1}{8}L$
		2d	$R - 0.70T$	A on 1st tap - 0.005	$\frac{1}{8}L$
		3d	$R - 0.90T$	A on 2d tap - 0.005	$\frac{1}{2}L$
		4th	$D$	A on 3d tap - 0.005	$\frac{1}{4}L \text{ to } \frac{1}{2}L$
	5	1st	$R + 0.37T$	$R - 0.010$	$\frac{1}{8}L$
		2d	$R + 0.63T$	A on 1st tap - 0.005	$\frac{1}{8}L$
		3d	$R + 0.82T$	A on 2d tap - 0.005	$\frac{1}{2}L$
		4th	$R + 0.94T$	A on 3d tap - 0.005	$\frac{1}{8}L \text{ to } \frac{1}{4}L$
		5th	$D$	A on 4th tap - 0.005	$\frac{1}{4}L \text{ to } \frac{1}{2}L$
	Square-Threaded Taps	2	1st	$R + 0.67T$	$R$
2d			$D$	A on 1st tap - 0.005	$\frac{1}{4}L \text{ to } \frac{1}{2}L$
3		1st	$R + 0.41T$	$R$	$\frac{1}{8}L \text{ to } \frac{1}{16}L$
		2d	$R + 0.080T$	A on 1st tap - 0.005	$\frac{1}{8}L \text{ to } \frac{1}{4}L$
		3d	$D$	A on 2d tap - 0.005	$\frac{1}{4}L \text{ to } \frac{1}{2}L$
4		1st	$R + 0.32T$	$R$	$\frac{1}{8}L$
		2d	$R + 0.62T$	A on 1st tap - 0.005	$\frac{1}{8}L$
		3d	$R + 0.90T$	A on 2d tap - 0.005	$\frac{1}{2}L$
		4th	$D$	A on 3d tap - 0.005	$\frac{1}{4}L \text{ to } \frac{1}{2}L$
5		1st	$R - 0.26T$	$R$	$\frac{1}{8}L$
		2d	$R - 0.50T$	A on 1st tap - 0.005	$\frac{1}{8}L$
		3d	$R - 0.72T$	A on 2d tap - 0.005	$\frac{1}{2}L$
		4th	$R - 0.92T$	A on 3d tap - 0.005	$\frac{1}{8}L \text{ to } \frac{1}{4}L$
		5th	$D$	A on 4th tap - 0.005	$\frac{1}{4}L \text{ to } \frac{1}{2}L$

## Drill Hole Sizes for Acme Threads

Many tap and die manufacturers and vendors make available to their customers computer programs designed to calculate drill hole sizes for all the Acme threads in their ranges from the basic dimensions. The large variety and combination of dimensions for such tools prevent inclusion of a complete set of tables of tap drills for Acme taps in this Handbook. The following formulas (dimensions in inches) for calculating drill hole sizes for Acme



threads are derived from the American National Standard, ASME/ANSI B1.5-1988, Acme Screw Threads.

To select a tap drill size for an Acme thread, first calculate the maximum and minimum internal product minor diameters for the thread to be produced. (Dimensions for general purpose, centralizing, and stub Acme screw threads are given in the Threads and Threading section, starting on page 1792.) Then select a drill that will yield a finished hole somewhere between the established maximum and minimum product minor diameters. Consider staying close to the maximum product limit in selecting the hole size, to reduce the amount of material to be removed when cutting the thread. If there is no standard drill size that matches the hole diameter selected, it may be necessary to drill and ream, or bore the hole to size, to achieve the required hole diameter.

Diameters of General-Purpose Acme screw threads of Classes 2G, 3G, and 4G may be calculated from:

$$\begin{aligned} \text{minimum diameter} &= \text{basic major diameter} - \text{pitch} \\ \text{maximum diameter} &= \text{minimum minor diameter} + 0.05 \times \text{pitch} \\ \text{pitch} &= 1/\text{number of threads per inch} \end{aligned}$$

For example,  $\frac{1}{2}$ -10 Acme 2G, pitch = 1/10 = 0.1

$$\begin{aligned} \text{minimum diameter} &= 0.5 - 0.1 = 0.4 \\ \text{maximum diameter} &= 0.4 + (0.05 \times 0.1) = 0.405 \\ \text{drill selected} &= \text{letter X or } 0.3970 + 0.0046 \text{ (probable oversize)} = 0.4016 \end{aligned}$$

Similarly, diameters of Acme Centralizing screw threads of Classes 2C, 3C, and 4C may be calculated from:

$$\begin{aligned} \text{minimum diameter} &= \text{basic major diameter} - 0.9 \times \text{pitch} \\ \text{maximum diameter} &= \text{minimum minor diameter} + 0.05 \times \text{pitch} \\ \text{pitch} &= 1/\text{number of threads per inch} \end{aligned}$$

For example,  $\frac{1}{2}$ -10 Acme 2C, pitch = 1/10 = 0.1:

$$\begin{aligned} \text{minimum diameter} &= 0.5 - (0.9 \times 0.1) = 0.41 \\ \text{maximum diameter} &= 0.41 + (0.05 \times 0.1) = 0.415. \text{drill selected} = \frac{13}{32} \text{ or } 0.4062 + 0.0046 \\ &\text{(probable oversize)} = 0.4108. \end{aligned}$$

Diameters for Acme Centralizing screw threads of Classes 5C and 6C (not recommended for new designs) may be calculated from:

$$\begin{aligned} \text{minimum diameter} &= [\text{basic major diameter} - (0.025 \sqrt{\text{basic major diameter}})] - 0.9 \times \text{pitch} \\ \text{maximum diameter} &= \text{minimum minor diameter} + 0.05 \times \text{pitch} \\ \text{pitch} &= 1/\text{number of threads per inch}. \end{aligned}$$

For example,  $\frac{1}{2}$ -10 Acme 5C, pitch = 1/10 = 0.1

$$\begin{aligned} \text{minimum diameter} &= [0.5 - (0.025 \sqrt{0.5})] - (0.9 \times 0.1) = 0.3923 \\ \text{maximum diameter} &= 0.3923 + (0.05 \times 0.1) = 0.3973 \\ \text{drill selected} &= \frac{25}{64} \text{ or } 0.3906 + 0.0046 \text{ (probable oversize)} = 0.3952 \end{aligned}$$

**British Standard Screwing Taps for ISO Metric Threads.**—BS 949: Part 1: 1976 provides dimensions and tolerances for screwing taps for ISO metric coarse-pitch series threads in accordance with BS 3643: Part 2; and for metric fine-pitch series threads in accordance with BS 3643: Part 3.

Table 1 provides dimensional data for the cutting portion of cut-thread taps for coarse-series threads of ISO metric sizes. The sizes shown were selected from the first-choice combinations of diameter and pitch listed in BS 3643:Part 1:1981 (1998). Table 16 provides similar data for ground-thread taps for both coarse- and fine-pitch series threads of ISO metric sizes.

**Table 1. British Standard Screwing Taps for ISO Metric Threads; Dimensional Limits for the Threaded Portion of Cut Taps—Coarse Pitch Series BS 949: Part 1: 1976**

Designation	Pitch	Major Diameter		Pitch Diameter			Tolerance on Thread Angle, Degrees
		Minimum <sup>a</sup>	Basic	Max.	Min.	Min.	
M1	0.25	1.030	0.838	0.875	0.848	4.0	
M1.2	0.25	1.230	1.038	1.077	1.048	4.0	
M1.6	0.35	1.636	1.373	1.417	1.385	3.4	
M2	0.40	2.036	1.740	1.786	1.752	3.2	
M2.5	0.45	2.539	2.208	2.259	2.221	3.0	
M3	0.50	3.042	2.675	2.730	2.689	2.9	
M4	0.70	4.051	3.545	3.608	3.562	2.4	
M5	0.80	5.054	4.480	4.547	4.498	2.3	
M6	1.00	6.060	5.350	5.424	5.370	2.0	
M8	1.25	8.066	7.188	7.270	7.210	1.8	
M10	1.50	10.072	9.026	9.116	9.050	1.6	
M12	1.75	12.078	10.863	10.961	10.889	1.5	
M16	2.00	16.084	14.701	14.811	14.729	1.4	
M20	2.50	20.093	18.376	18.497	18.407	1.3	
M24	3.00	24.102	22.051	22.183	22.085	1.2	
M30	3.50	30.111	27.727	27.874	27.764	1.1	
M36	4.00	36.117	33.402	33.563	33.441	1.0	

<sup>a</sup>See notes under Table 2.**Table 2. British Standard Screwing Taps for ISO Metric Threads; Dimensional Limits for the Threaded Portion of Ground Taps—Coarse and Fine-Pitch BS 949: Part 1: 1976**

Thread		All Classes of Taps		Class 1 Taps		Class 2 Taps		Class 3 Taps		Tolerance on 1/2 Thd Angle	
Designation	Nominal Major Dia. (basic) $d$	Pitch $p$	Min. Major Dia. $d_{min}$ <sup>a</sup>	Basic Pitch Dia. $d_2$	Pitch Diameter						
					$d_{2min}$	$d_{2max}$	$d_{2min}$	$d_{2max}$	$d_{2min}$	$d_{2max}$	
COARSE-PITCH THREAD SERIES											
M1	1	0.25	1.022	0.838	0.844	0.855	...	...	...	...	±60'
M1.2	1.2	0.25	1.222	1.038	1.044	1.055	...	...	...	...	±60'
M1.6	1.6	0.35	1.627	1.373	1.380	1.393	1.393	1.407	...	...	±50'
M2	2	0.40	2.028	1.740	1.747	1.761	1.761	1.776	...	...	±40'
M2.5	2.5	0.45	2.530	2.208	2.216	2.231	2.231	2.246	...	...	±38'
M3	3	0.50	3.032	2.675	2.683	2.699	2.699	2.715	2.715	2.731	±36'
M4	4	0.70	4.038	3.545	3.555	3.574	3.574	3.593	3.593	3.612	±30'
M5	5	0.80	5.040	4.480	4.490	4.510	4.510	4.530	4.530	4.550	±26'
M6	6	1.00	6.047	5.350	5.362	5.385	5.385	5.409	5.409	5.433	±24'
M8	8	1.25	8.050	7.188	7.201	7.226	7.226	7.251	7.251	7.276	±22'
M10	10	1.50	10.056	9.026	9.040	9.068	9.068	9.096	9.096	9.124	±20'
M12	12	1.75	12.064	10.863	10.879	10.911	10.911	10.943	10.943	10.975	±19'
M16	16	2.00	16.068	14.701	14.718	14.752	14.752	14.786	14.786	14.820	±18'
M20	20	2.50	20.072	18.376	18.394	18.430	18.430	18.466	18.466	18.502	±16'
M24	24	3.00	24.085	22.051	22.072	22.115	22.115	22.157	22.157	22.199	±14'

**Table 2. (Continued) British Standard Screwing Taps for ISO Metric Threads; Dimensional Limits for the Threaded Portion of Ground Taps— Coarse and Fine-Pitch BS 949: Part 1: 1976**

Thread			All Classes of Taps		Class 1 Taps		Class 2 Taps		Class 3 Taps		Tolerance on 1/2 Thd Angle
Designation	Nominal Major Dia. (basic) <i>d</i>	Pitch <i>P</i>	Min. Major Dia. <i>d<sub>2min</sub></i> <sup>a</sup>	Basic Pitch Dia. <i>d<sub>2</sub></i>	Pitch Diameter						
					<i>d<sub>1min</sub></i>	<i>d<sub>1max</sub></i>	<i>d<sub>2min</sub></i>	<i>d<sub>2max</sub></i>	<i>d<sub>3min</sub></i>	<i>d<sub>3max</sub></i>	
M30	30	3.50	30.090	27.727	27.749	27.794	27.794	27.839	27.839	27.884	±15'
M36	36	4.00	36.094	33.402	33.426	33.473	33.473	33.520	33.520	33.567	±12'
FINE-PITCH THREAD SIZES											
M1 × 0.2	1	0.20	1.020	0.870	0.875	0.885	...	...	...	...	±70'
M1.2 × 0.2	1.2	0.20	1.220	1.070	1.075	1.085	...	...	...	...	±70'
M1.6 × 0.2	1.6	0.20	1.621	1.470	1.475	1.485	...	...	...	...	±70'
M2 × 0.25	2	0.25	2.024	1.838	1.844	1.856	...	...	...	...	±60'
M2.5 × 0.35	2.5	0.35	2.527	2.273	2.280	2.293	2.293	2.307	...	...	±50'
M3 × 0.35	3	0.35	3.028	2.773	2.780	2.794	2.794	2.809	...	...	±50'
M4 × 0.5	4	0.50	4.032	3.675	3.683	3.699	3.699	3.715	3.715	3.731	±36'
M5 × 0.5	5	0.50	5.032	4.675	4.683	4.699	4.699	4.715	4.715	4.731	±36'
M6 × 0.75	6	0.75	6.042	5.513	5.524	5.545	5.545	5.566	5.566	5.587	±28'
M8 × 1	8	1.00	8.047	7.350	7.362	7.385	7.385	7.409	7.409	7.433	±24'
M10 × 1.25	10	1.25	10.050	9.188	9.201	9.226	9.226	9.251	9.251	9.276	±22'
M12 × 1.25	12	1.25	12.056	11.188	11.202	11.230	11.230	11.258	11.258	11.286	±22'
M16 × 1.5	16	1.50	16.060	15.026	15.041	15.071	15.071	15.101	15.101	15.131	±20'
M20 × 1.5	20	1.50	20.060	19.026	19.041	19.071	19.071	19.101	19.101	19.131	±20'
M24 × 2	24	2.00	24.072	22.701	22.719	22.755	22.755	22.791	22.791	22.827	±18'
M30 × 2	30	2.00	30.072	28.701	28.719	28.755	28.755	28.791	28.791	28.827	±18'

<sup>a</sup> The maximum tap major diameter, *d* max, is not specified and is left to the manufacturer's discretion.

All dimensions are in millimeters. The thread sizes in the table have been selected from the preferred series shown in BS 3643:Part 1:1981 (1998). For other sizes, and for second and third choice combinations of diameters and pitches, see the Standard.

**Tolerance Classes of Taps:** Three tolerance classes (class 1, class 2, and class 3) are used for the designation of taps used for the production of nuts of the following classes:

nut classes 4H, 5H, 6H, 7H, and 8H, all having zero minimum clearance;

nut classes 4G, 5G, and 6G, all having positive minimum clearance.

The tolerances for the three classes of taps are stated in terms of a tolerance unit *t*, the value of which is equal to the pitch diameter tolerance,  $T_{D2}$ , grade 5, of the nut. Thus,  $t = T_{D2}$ , grade 5, of the nut. Taps of the different classes vary in the limits of size of the tap pitch diameter. The tolerance on the tap pitch diameter,  $T_{d2}$ , is the same for all three classes of taps (20 percent of *t*), but the position of the tolerance zone with respect to the basic pitch diameter depends upon the lower deviation value *Em* which is: for tap class 1,  $Em = +0.1t$ ; for tap class 2,  $Em = +0.3t$ ; and for tap class 3,  $Em = +0.5t$ .

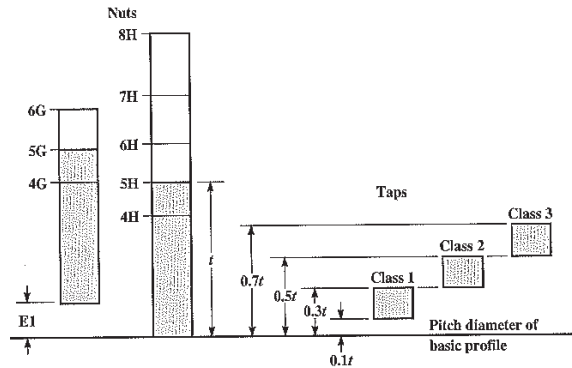

The disposition of the tolerances described is shown in the accompanying illustration of nut class tolerances compared against tap class tolerances. The distance  $EI$  shown in this illustration is the minimum clearance, which is zero for  $H$  classes and positive for  $G$  classes of nuts.

**Choice of Tap Tolerance Class:** Unless otherwise specified, class 1 taps are used for nuts of classes 4H and 5H; class 2 taps for nuts of classes 6H, 4G, and 5G; and class 3 taps for nuts of classes 7H, 8H, and 6G. This relationship of tap and nut classes is a general one, since the accuracy of tapping varies with a number of factors such as the material being tapped, the condition of the machine tool used, the tapping attachment used, the tapping speed, and the lubricant.

**Tap Major Diameter:** Except when a screwed connection has to be tight against gaseous or liquid pressure, it is undesirable for the mating threads to bear on the roots and crests. By avoiding contact in these regions of the threads, the opposite flanks of the two threads are allowed to make proper load bearing contact when the connection is tightened. In general, the desired clearance between crests and roots of mating threads is obtained by increasing the major and minor diameters of the internal thread. Such an increase in the minor diameter is already provided on threads such as the ISO metric thread, in which there is a basic clearance between the crests of minimum size nuts and the roots of maximum size bolts. For this reason, and the fact that taps are susceptible to wear on the crests of their threads, a minimum size is specified for the major diameter of new taps which provides a reasonable margin for the wear of their crests and at the same time provides the desired clearance at the major diameter of the hole. These minimum major diameters for taps are shown in Tables 1 and 16. The maximum tap major diameter is not specified and is left to the manufacturer to take advantage of this concession to produce taps with as liberal a margin possible for wear on the major diameter.

**Tapping Square Threads.**—If it is necessary to tap square threads, this should be done by using a set of taps that will form the thread by a progressive cutting action, the taps varying in size in order to distribute the work, especially for threads of comparatively coarse pitch. From three to five taps may be required in a set, depending upon the pitch. Each tap should have a pilot to steady it. The pilot of the first tap has a smooth cylindrical end from 0.003 to 0.005 inch smaller than the hole, and the pilots of following taps should have teeth.

## STANDARD TAPERS

## Standard Tapers

Certain types of small tools and machine parts, such as twist drills, end mills, arbors, lathe centers, etc., are provided with taper shanks which fit into spindles or sockets of corresponding taper, thus providing not only accurate alignment between the tool or other part and its supporting member, but also more or less frictional resistance for driving the tool. There are several standards for "self-holding" tapers, but the American National, Morse, and the Brown & Sharpe are the standards most widely used by American manufacturers.

The name *self-holding* has been applied to the smaller tapers—like the Morse and the Brown & Sharpe—because, where the angle of the taper is only 2 or 3 degrees, the shank of a tool is so firmly seated in its socket that there is considerable frictional resistance to any force tending to turn or rotate the tool relative to the socket. The term "self-holding" is used to distinguish relatively small tapers from the larger or *self-releasing* type. A milling machine spindle having a taper of  $3\frac{1}{2}$  inches per foot is an example of a self-releasing taper. The included angle in this case is over 16 degrees and the tool or arbor requires a positive locking device to prevent slipping, but the shank may be released or removed more readily than one having a smaller taper of the self-holding type.

**Morse Taper.**—Dimensions relating to Morse standard taper shanks and sockets may be found in an accompanying table. The taper for different numbers of Morse tapers is slightly different, but it is approximately  $\frac{3}{8}$  inch per foot in most cases. The table gives the actual tapers, accurate to five decimal places. Morse taper shanks are used on a variety of tools, and exclusively on the shanks of twist drills. Dimensions for Morse Stub Taper Shanks are given in Table 1a.

**Brown & Sharpe Taper.**—This standard taper is used for taper shanks on tools such as end mills and reamers, the taper being approximately  $\frac{1}{2}$  inch per foot for all sizes except for taper No. 10, where the taper is 0.5161 inch per foot. Brown & Sharpe taper sockets are used for many arbors, collets, and machine tool spindles, especially milling machines and grinding machines. In many cases there are a number of different lengths of sockets corresponding to the same number of taper; all these tapers, however, are of the same diameter at the small end.

**Jarno Taper.**—The Jarno taper was originally proposed by Oscar J. Beale of the Brown & Sharpe Mfg. Co. This taper is based on such simple formulas that practically no calculations are required when the number of taper is known. The taper per foot of all Jarno taper sizes is 0.600 inch on the diameter. The diameter at the large end is as many eighths, the diameter at the small end is as many tenths, and the length as many half inches as are indicated by the number of the taper. For example, a No. 7 Jarno taper is  $\frac{7}{8}$  inch in diameter at the large end;  $\frac{7}{10}$ , or 0.700 inch at the small end; and  $\frac{7}{2}$ , or  $3\frac{1}{2}$  inches long; hence, diameter at large end = No. of taper + 8; diameter at small end = No. of taper + 10; length of taper = No. of taper + 2. The Jarno taper is used on various machine tools, especially profiling machines and die-sinking machines. It has also been used for the headstock and tailstock spindles of some lathes.

*American National Standard Machine Tapers:* This standard includes a self-holding series (Tables 2, 3, 4, 5 and 7a) and a steep taper series, Table 6. The self-holding taper series consists of 22 sizes which are listed in Table 7a. The reference gage for the self-holding tapers is a plug gage. Table 7b gives the dimensions and tolerances for both plug and ring gages applying to this series. Tables 2 through 5 inclusive give the dimensions for self-holding taper shanks and sockets which are classified as to (1) means of transmitting torque from spindle to the tool shank, and (2) means of retaining the shank in the socket. The steep machine tapers consist of a preferred series (bold-face type, Table 6) and an intermediate series (light-face type). A self-holding taper is defined as "a taper with an

angle small enough to hold a shank in place ordinarily by friction without holding means. (Sometimes referred to as slow taper.) A steep taper is defined as "a taper having an angle sufficiently large to insure the easy or self-releasing feature." The term "gage line" indicates the basic diameter at or near the large end of the taper.

Table 1a. Morse Stub Taper Shanks

No. of Taper	Taper per Foot <sup>a</sup>	Taper per Inch <sup>b</sup>	Small End of Plug, <sup>b</sup> D	Dia. End of Socket, <sup>a</sup> A	Shank		Tang	
					Total Length, B	Depth, C	Thickness, E	Length, F
1	0.59858	0.049882	0.4314	0.475	1 <sup>1</sup> / <sub>5</sub>	1 <sup>1</sup> / <sub>8</sub>	1 <sup>3</sup> / <sub>64</sub>	5 <sup>1</sup> / <sub>16</sub>
2	0.59941	0.049951	0.6469	0.700	1 <sup>1</sup> / <sub>5</sub>	1 <sup>7</sup> / <sub>5</sub>	9 <sup>1</sup> / <sub>64</sub>	7 <sup>1</sup> / <sub>16</sub>
3	0.60235	0.050196	0.8753	0.938	2	1 <sup>3</sup> / <sub>4</sub>	2 <sup>5</sup> / <sub>64</sub>	8 <sup>1</sup> / <sub>16</sub>
4	0.62326	0.051938	1.1563	1.231	2 <sup>3</sup> / <sub>5</sub>	2 <sup>1</sup> / <sub>16</sub>	2 <sup>1</sup> / <sub>64</sub>	11 <sup>1</sup> / <sub>16</sub>
5	0.63151	0.052626	1.6526	1.748	3	2 <sup>1</sup> / <sub>16</sub>	3 <sup>1</sup> / <sub>4</sub>	15 <sup>1</sup> / <sub>16</sub>
No. of Taper	Tang		Socket			Tang Slot		
	Radius of Mill, G	Diameter, H	Plug Depth, P	Min. Depth of Tapered Hole		Socket End to Tang Slot, M	Width, N	Length, O
			Drilled X	Reamed Y				
1	3 <sup>1</sup> / <sub>16</sub>	1 <sup>1</sup> / <sub>32</sub>	7 <sup>1</sup> / <sub>8</sub>	5 <sup>1</sup> / <sub>16</sub>	2 <sup>1</sup> / <sub>32</sub>	2 <sup>1</sup> / <sub>32</sub>	1 <sup>1</sup> / <sub>16</sub>	2 <sup>1</sup> / <sub>16</sub>
2	7 <sup>1</sup> / <sub>32</sub>	2 <sup>1</sup> / <sub>16</sub>	1 <sup>1</sup> / <sub>16</sub>	1 <sup>1</sup> / <sub>32</sub>	1 <sup>1</sup> / <sub>16</sub>	1 <sup>1</sup> / <sub>16</sub>	1 <sup>1</sup> / <sub>16</sub>	1 <sup>1</sup> / <sub>16</sub>
3	3 <sup>1</sup> / <sub>32</sub>	1 <sup>1</sup> / <sub>16</sub>	1 <sup>1</sup> / <sub>4</sub>	1 <sup>1</sup> / <sub>8</sub>	1 <sup>1</sup> / <sub>16</sub>	1 <sup>1</sup> / <sub>16</sub>	1 <sup>1</sup> / <sub>32</sub>	1 <sup>1</sup> / <sub>8</sub>
4	3 <sup>1</sup> / <sub>8</sub>	1 <sup>1</sup> / <sub>32</sub>	1 <sup>7</sup> / <sub>16</sub>	1 <sup>1</sup> / <sub>16</sub>	1 <sup>1</sup> / <sub>2</sub>	1 <sup>3</sup> / <sub>16</sub>	1 <sup>1</sup> / <sub>32</sub>	1 <sup>1</sup> / <sub>8</sub>
5	3 <sup>1</sup> / <sub>16</sub>	1 <sup>1</sup> / <sub>16</sub>	1 <sup>13</sup> / <sub>16</sub>	1 <sup>1</sup> / <sub>16</sub>	1 <sup>7</sup> / <sub>8</sub>	1 <sup>7</sup> / <sub>16</sub>	2 <sup>1</sup> / <sub>32</sub>	1 <sup>1</sup> / <sub>4</sub>

<sup>a</sup>These are basic dimensions.

<sup>b</sup>These dimensions are calculated for reference only.

All dimensions in inches.

Radius J is 3<sup>1</sup>/<sub>64</sub>, 1<sup>1</sup>/<sub>16</sub>, 1<sup>1</sup>/<sub>64</sub>, 3<sup>1</sup>/<sub>32</sub>, and 1<sup>1</sup>/<sub>8</sub> inch respectively for Nos. 1, 2, 3, 4, and 5 tapers.

Table 1b. Morse Standard Taper Shanks

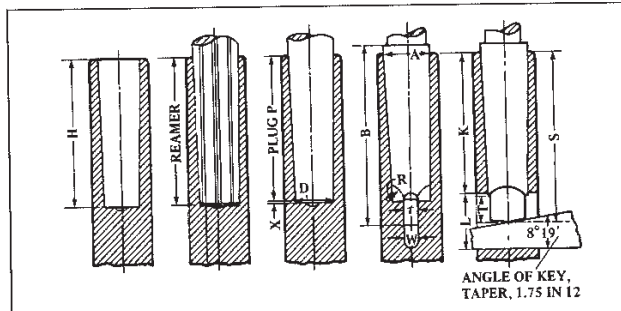

ANGLE OF KEY, TAPER, 1.75 IN 12

No. of Taper	Taper per Foot	Taper per Inch	Small End of Plug <i>D</i>	Diameter End of Socket <i>A</i>	Shank		Depth of Hole <i>H</i>
					Length <i>B</i>	Depth <i>S</i>	
0	0.62460	0.05205	0.252	0.3561	$2\frac{1}{32}$	$2\frac{1}{32}$	$2\frac{1}{32}$
1	0.59858	0.04988	0.369	0.475	$2\frac{7}{16}$	$2\frac{7}{16}$	$2\frac{3}{32}$
2	0.59941	0.04995	0.572	0.700	$3\frac{1}{8}$	$2\frac{5}{16}$	$2\frac{3}{64}$
3	0.60235	0.05019	0.778	0.938	$3\frac{3}{8}$	$3\frac{11}{16}$	$3\frac{1}{4}$
4	0.62326	0.05193	1.020	1.231	$4\frac{3}{8}$	$4\frac{3}{8}$	$4\frac{1}{8}$
5	0.63151	0.05262	1.475	1.748	$6\frac{1}{8}$	$5\frac{3}{8}$	$5\frac{1}{4}$
6	0.62565	0.05213	2.116	2.494	$8\frac{9}{16}$	$8\frac{1}{4}$	$7\frac{21}{64}$
7	0.62400	0.05200	2.750	3.270	$11\frac{3}{8}$	$11\frac{1}{4}$	$10\frac{5}{64}$
Plug Depth <i>P</i>	Tang or Tongue				Keyway		Keyway to End <i>K</i>
	Thickness <i>t</i>	Length <i>T</i>	Radius <i>R</i>	Dia.	Width <i>W</i>	Length <i>L</i>	
2	0.1562	$\frac{1}{4}$	$\frac{5}{32}$	0.235	$\frac{11}{64}$	$\frac{9}{16}$	$1\frac{15}{64}$
$2\frac{1}{8}$	0.2031	$\frac{3}{8}$	$\frac{3}{16}$	0.343	0.218	$\frac{3}{4}$	$2\frac{1}{16}$
$2\frac{1}{16}$	0.2500	$\frac{7}{16}$	$\frac{1}{4}$	$\frac{7}{32}$	0.266	$\frac{7}{8}$	$2\frac{1}{2}$
$3\frac{3}{16}$	0.3125	$\frac{9}{16}$	$\frac{9}{32}$	$2\frac{1}{32}$	0.328	$1\frac{3}{16}$	$3\frac{1}{16}$
$4\frac{1}{16}$	0.4687	$\frac{3}{4}$	$\frac{5}{16}$	$3\frac{1}{32}$	0.484	$1\frac{1}{4}$	$3\frac{3}{8}$
$5\frac{3}{16}$	0.6250	$\frac{3}{4}$	$\frac{3}{8}$	$1\frac{15}{32}$	0.656	$1\frac{1}{2}$	$4\frac{15}{64}$
$7\frac{1}{4}$	0.7500	$1\frac{1}{8}$	$\frac{1}{2}$	2	0.781	$1\frac{3}{4}$	7
10	1.1250	$1\frac{3}{8}$	$\frac{3}{4}$	$2\frac{3}{8}$	1.156	$2\frac{3}{8}$	$9\frac{1}{2}$

Table 2. American National Standard Taper Drive with Tang, Self-Holding Tapers ANSI/ASME B5.10-1994

No. of Taper	Diameter at Gage Line (1) A	Shank		Tang			
		Total Length of Shank B	Gage Line to End of Shank C	Thickness E	Length F	Radius of Mill G	Diameter H
0.239	0.23922	1.28	1.19	0.125	0.19	0.19	0.18
0.299	0.29968	1.59	1.50	0.156	0.25	0.19	0.22
0.375	0.37525	1.97	1.88	0.188	0.31	0.19	0.28
1	0.47500	2.56	2.44	0.203	0.38	0.19	0.34
2	0.70000	3.13	2.94	0.250	0.44	0.25	0.53
3	0.93800	3.88	3.69	0.312	0.56	0.22	0.72
4	1.23100	4.88	4.63	0.469	0.63	0.31	0.97
4½	1.50000	5.38	5.13	0.562	0.69	0.38	1.20
5	1.74800	6.12	5.88	0.625	0.75	0.38	1.41
6	2.49400	8.25	8.25	0.750	1.13	0.50	2.00

No. of Taper	Radius J	Socket		Tang Slot			
		Min. Depth of Hole K		Gage Line to Tang Slot M	Width N	Length O	Shank End to Back of Tang Slot P
		Drilled	Reamed				
0.239	0.03	1.06	1.00	0.94	0.141	0.38	0.13
0.299	0.03	1.31	1.25	1.17	0.172	0.50	0.17
0.375	0.05	1.63	1.56	1.47	0.203	0.63	0.22
1	0.05	2.19	2.16	2.06	0.218	0.75	0.38
2	0.06	2.66	2.61	2.50	0.266	0.88	0.44
3	0.08	3.31	3.25	3.06	0.328	1.19	0.56
4	0.09	4.19	4.13	3.88	0.484	1.25	0.50
4½	0.13	4.62	4.56	4.31	0.578	1.38	0.56
5	0.13	5.31	5.25	4.94	0.656	1.50	0.56
6	0.16	7.41	7.33	7.00	0.781	1.75	0.50

All dimensions are in inches. (1) See Table 7b for plug and ring gage dimensions.

**Tolerances:** For shank diameter A at gage line, +0.002 - 0.000; for hole diameter A, +0.000 - 0.002. For tang thickness E up to No. 5 inclusive, +0.000 - 0.006; No. 6, +0.000 - 0.008. For width N of tang slot up to No. 5 inclusive, +0.006; -0.000; No. 6, +0.008 - 0.030. For centrality of tang E with center line of taper, 0.0025 (0.005 total indicator variation). These centrality tolerances also apply to the tang slot N. On rate of taper, all sizes 0.002 per foot. This tolerance may be applied on shanks only in the direction which increases the rate of taper and on sockets only in the direction which decreases the rate of taper. Tolerances for two-decimal dimensions are plus or minus 0.010, unless otherwise specified.



Table 3. American National Standard Taper Drive with Keeper Key Slot, Self-Holding Tapers ANSI/ASME B5.10-1994

No. of Taper	Shank				Tang				Socket		
	Dia. at Gage Line (J) A	Total Length B	Gage Line to End C	Thickness E	Length F	Radius of Mill G	Diameter H	Radius J	Min. Depth of Hole K		Gage Line to Tang Slot M
									Drill	Ream	
3	0.938	3.88	3.69	0.312	0.56	0.28	0.78	0.08	3.31	3.25	3.06
4	1.231	4.88	4.63	0.469	0.63	0.31	0.97	0.09	4.19	4.13	3.88
4½	1.500	5.38	5.13	0.562	0.69	0.38	1.20	0.13	4.63	4.56	4.32
5	1.748	6.13	5.88	0.625	0.75	0.38	1.41	0.13	5.31	5.25	4.94
6	2.494	8.56	8.25	0.750	1.13	0.50	2.00	0.16	7.41	7.33	7.00
7	3.270	11.63	11.25	1.125	1.38	0.75	2.63	0.19	10.16	10.08	9.50

No. of Taper	Tang Slot			Keeper Slot in Shank			Keeper Slot in Socket		
	Width N	Length O	Shank End to Back of Slot P	Gage Line to Bottom of Slot Y	Length X	Width N'	Gage Line to Front of Slot Y	Length Z	Width N'
3	0.328	1.19	0.56	1.03	1.13	0.266	1.13	1.19	0.266
4	0.484	1.25	0.50	1.41	1.19	0.391	1.50	1.25	0.391
4½	0.578	1.38	0.56	1.72	1.25	0.453	1.81	1.38	0.453
5	0.656	1.50	0.56	2.00	1.38	0.516	2.13	1.50	0.516
6	0.781	1.75	0.50	2.13	1.63	0.641	2.25	1.75	0.641
7	1.156	2.63	0.88	2.50	1.69	0.766	2.63	1.81	0.766

All dimensions are in inches. (1) See Table 7b for plug and ring gage dimensions.  
 Tolerances: For shank diameter A at gage line, +0.002, -0; for hole diameter A, +0, -0.002. For tang thickness E up to No. 5 inclusive, +0, -0.006; larger than No. 5, +0, -0.008. For width of slots N and N' up to No. 5 inclusive, +0.006, -0; larger than No. 5, +0.008, -0. For centrality of tang E with center line of taper 0.0025 (0.005 total indicator variation). These centrality tolerances also apply to slots N and N'. On rate of taper, see footnote in Table 2. Tolerances for two-decimal dimensions are ±0.010 unless otherwise specified.

Table 4. American National Standard Nose Key Drive with Keeper Key Slot, Self-Holding Tapers ANSI/ASME B5.10-1994

Taper	A(1)	B'	C	Q	F	I	R	S
200	2.000	5.13		0.25	1.38	1.63	1.010	0.562
250	2.500	5.88		0.25	1.38	2.06	1.010	0.562
300	3.000	6.63	Min	0.25	1.63	2.50	2.010	0.562
350	3.500	7.44	0.003	0.31	2.00	2.94	2.010	0.562
400	4.000	8.19	Max	0.31	2.13	3.31	2.010	0.562
450	4.500	9.00	0.035	0.38	2.38	3.81	3.010	0.812
500	5.000	9.75	for	0.38	2.50	4.25	3.010	0.812
600	6.000	11.51	all	0.44	3.00	5.19	3.010	0.812
800	8.000	14.38	sizes	0.50	3.50	7.00	4.010	1.062
1000	10.000	17.44		0.63	4.50	8.75	4.010	1.062
1200	12.000	20.50		0.75	5.38	10.50	4.010	1.062

Taper	D	D*	W	X	N'	R'	S'	T
200	1.41	0.375	3.44	1.56	0.656	1.000	0.50	4.75
250	1.66	0.375	3.69	1.56	0.781	1.000	0.50	5.50
300	2.25	0.375	4.06	1.56	1.031	2.000	0.50	6.25
350	2.50	0.375	4.88	2.00	1.031	2.000	0.50	6.94
400	2.75	0.375	5.31	2.25	1.031	2.000	0.50	7.69
450	3.00	0.500	5.88	2.44	1.031	3.000	0.75	8.38
500	3.25	0.500	6.44	2.63	1.031	3.000	0.75	9.13
600	3.75	0.500	7.44	3.00	1.281	3.000	0.75	10.56
800	4.75	0.500	9.56	4.00	1.781	4.000	1.00	13.50
1000	...	...	11.50	4.75	2.031	4.000	1.00	16.31
1200	...	...	13.75	5.75	2.031	4.000	1.00	19.00

Taper	U	V	M	N	O	P	Y	Z
200	1.81	1.00	4.50	0.656	1.56	0.94	2.00	1.59
250	2.25	1.00	5.19	0.781	1.94	1.25	2.25	1.69
300	2.75	1.00	5.94	1.031	2.19	1.50	2.63	1.69
350	3.19	1.25	6.75	1.031	2.19	1.50	3.00	2.13
400	3.63	1.25	7.50	1.031	2.19	1.50	3.25	2.38
450	4.19	1.50	8.00	1.031	2.75	1.75	3.63	2.56
500	4.63	1.50	8.75	1.031	2.75	1.75	4.00	2.75
600	5.50	1.75	10.13	1.281	3.25	2.06	4.63	3.25
800	7.38	2.00	12.88	1.781	4.25	2.75	5.75	4.25
1000	9.19	2.50	15.75	2.031	5.00	3.31	7.00	5.00
1200	11.00	3.00	18.50	2.531	6.00	4.00	8.25	6.00

\*Thread is UNF-2B for hole; UNF-2A for screw. (1) See Table 7b for plug and ring gage dimensions.

All dimensions are in inches. AE is 0.005 greater than one-half of A. Width of drive key R' is 0.001 less than width R' of keyway. Tolerances: For diameter A of hole at gage line, +0, -0.002; for diameter A of shank at gage line, +0.002, -0; for width of slots N and N', +0.008, -0; for width of drive keyway R' in socket, +0, -0.001; for width of drive keyway R in shank, 0.010, -0; for centrality of slots N and N' with center line of spindle, 0.007; for centrality of keyway with spindle center line: for R, 0.004 and for R', 0.002 T.I.V. On rate of taper, see footnote in Table 2. Two-decimal dimensions, ±0.010 unless otherwise specified.

Table 5. American National Standard Nose Key Drive with Drawbolt, Self-Holding Tapers ANSI/ASME B5.10-1994

Sockets											
No. of Taper	Dia. at Gage Line A <sup>a</sup>	Drive Key			Drive Keyway			Gage Line to Front of Relief T	Dia. of Relief U	Depth of Relief V	Dia. of Draw Bolt Hole d
		Screw Holes		Width R'	Width R''	Depth S'					
		Center Line to Center of Screw D	UNF 2B Hole UNF 2A Screw D'								
200	2.00	1.41	0.38	0.999	1.000	0.50	4.75	1.81	1.00	1.00	
250	2.50	1.66	0.38	0.999	1.000	0.50	5.50	2.25	1.00	1.00	
300	3.00	2.25	0.38	1.999	2.000	0.50	6.25	2.75	1.00	1.13	
350	3.50	2.50	0.38	1.999	2.000	0.50	6.94	3.19	1.25	1.13	
400	4.00	2.75	0.38	1.999	2.000	0.50	7.69	3.63	1.25	1.63	
450	4.50	3.00	0.50	2.999	3.000	0.75	8.38	4.19	1.50	1.63	
500	5.00	3.25	0.50	2.999	3.000	0.75	9.13	4.63	1.50	1.63	
600	6.00	3.75	0.50	2.999	3.000	0.75	10.56	5.50	1.75	2.25	
800	8.00	4.75	0.50	3.999	4.000	1.00	13.50	7.38	2.00	2.25	
1000	10.00	...	...	3.999	4.000	1.00	16.31	9.19	2.50	2.25	
1200	12.00	...	...	3.999	4.000	1.00	19.00	11.00	3.00	2.25	

<sup>a</sup> See Table 7b for plug and ring gage dimensions.

Shanks										
No. of Taper	Length from Gage Line B'	Drawbar Hole					Drive Keyway			
		Dia. UNC-2B AL	Depth of Drilled Hole E	Depth of Thread AP	Dia. of Counter Bore G	Gage Line to First Thread AO	Depth of 60° Chamfer J	Width R	Depth S	Center Line to Bottom of Keyway AE
200	5.13	7/8-9	2.44	1.75	0.91	4.78	0.13	1.010	0.562	1.005
250	5.88	7/8-9	2.44	1.75	0.91	5.53	0.13	1.010	0.562	1.255
300	6.63	1-8	2.75	2.00	1.03	6.19	0.19	2.010	0.562	1.505
350	7.44	1-8	2.75	2.00	1.03	7.00	0.19	2.010	0.562	1.755
400	8.19	1 1/4-6	4.00	3.00	1.53	7.50	0.31	2.010	0.562	2.005
450	9.00	1 1/2-6	4.00	3.00	1.53	8.31	0.31	3.010	0.812	2.255
500	9.75	1 1/2-6	4.00	3.00	1.53	9.06	0.31	3.010	0.812	2.505
600	11.31	2-4 1/2	5.31	4.00	2.03	10.38	0.50	3.010	0.812	3.005
800	14.38	2-4 1/2	5.31	4.00	2.03	13.44	0.50	4.010	1.062	4.005
1000	17.44	2-4 1/2	5.31	4.00	2.03	16.50	0.50	4.010	1.062	5.005
1200	20.50	2-4 1/2	5.31	4.00	2.03	19.56	0.50	4.010	1.062	6.005

All dimensions in inches.

Exposed length C is 0.003 minimum and 0.035 maximum for all sizes.

Drive Key D' screw sizes are 7/8-24 UNF-2A up to taper No. 400 inclusive and 1/2-20 UNF-2A for larger tapers.

Tolerances: For diameter A of hole at gage line, +0.000, -0.002 for all sizes; for diameter A of shank at gage line, +0.002, -0.000; for all sizes; for width of drive keyway R' in socket, +0.000, -0.001; for width of drive keyway R in shank, +0.010, -0.000; for centrality of drive keyway R', with center line of shank, 0.004 total indicator variation, and for drive keyway R', with center line of spindle, 0.002. On rate of taper, see footnote in Table 2. Tolerances for two-decimal dimensions are ±0.010 unless otherwise specified.

STANDARD TAPERS

913

**Table 6. ANSI Standard Steep Machine Tapers** *ANSI/ASME B5.10-1994*

No. of Taper	Taper per Foot <sup>a</sup>	Dia. at Gage Line <sup>b</sup>	Length Along Axis	No. of Taper	Taper per Foot <sup>a</sup>	Dia. at Gage Line <sup>b</sup>	Length Along Axis
5	3.500	0.500	0.6875	35	3.500	1.500	2.2500
<b>10</b>	<b>3.500</b>	<b>0.625</b>	<b>0.8750</b>	<b>40</b>	<b>3.500</b>	<b>1.750</b>	<b>2.5625</b>
15	3.500	0.750	1.0625	45	3.500	2.250	3.3125
<b>20</b>	<b>3.500</b>	<b>0.875</b>	<b>1.3125</b>	<b>50</b>	<b>3.500</b>	<b>2.750</b>	<b>4.0000</b>
25	3.500	1.000	1.5625	55	3.500	3.500	5.1875
<b>30</b>	<b>3.500</b>	<b>1.250</b>	<b>1.8750</b>	<b>60</b>	<b>3.500</b>	<b>4.250</b>	<b>6.3750</b>

<sup>a</sup>This taper corresponds to an included angle of 16°, 35', 39.4".

<sup>b</sup>The basic diameter at gage line is at large end of taper.

All dimensions given in inches.

The tapers numbered 10, 20, 30, 40, 50, and 60 that are printed in heavy-faced type are designated as the "Preferred Series." The tapers numbered 5, 15, 25, 35, 45, and 55 that are printed in light-faced type are designated as the "Intermediate Series."

**Table 7a. American National Standard Self-holding Tapers — Basic Dimensions** *ANSI/ASME B5.10-1994*

No. of Taper	Taper per Foot	Dia. at Gage Line <sup>a</sup>	Means of Driving and Holding <sup>a</sup>	Origin of Series
.239	0.50200	0.23922	Tang Drive With Shank Held in by Friction (See Table 2)	Brown & Sharpe Taper Series
.299	0.50200	0.29968		
.375	0.50200	0.37525		
1	0.59858	0.47500		
2	0.59941	0.70000		
3	0.60235	0.93800	Tang Drive With Shank Held in by Key (See Table 3)	Morse Taper Series
4	0.62326	1.23100		
4½	0.62400	1.50000		
5	0.63151	1.74800	Key Drive With Shank Held in by Key (See Table 4)	
6	0.62565	2.49400		
7	0.62400	3.27000	Key Drive With Shank Held in by Draw-bolt (See Table 5)	¼ Inch per Foot Taper Series
200	0.750	2.000		
250	0.750	2.500		
300	0.750	3.000		
350	0.750	3.500		
400	0.750	4.000		
450	0.750	4.500		
500	0.750	5.000		
600	0.750	6.000		
800	0.750	8.000		
1000	0.750	10.000		
1200	0.750	12.000		

<sup>a</sup>See illustrations above Tables 2 through 5.

All dimensions given in inches.

Table 7b. American National Standard Plug and Ring Gages for the Self-Holding Taper Series ANSI/ASME B5.10-1994

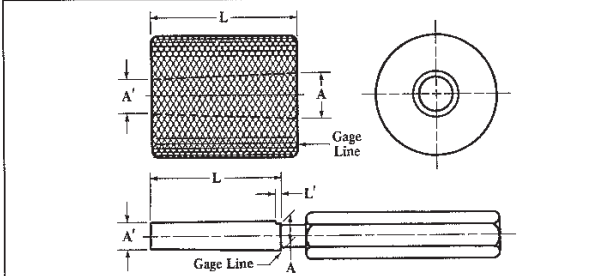

Nu. of Taper	Taper <sup>a</sup> per Foot	Diameter <sup>a</sup> at Gage Line A	Tolerances for Diameter A <sup>b</sup>			Diameter at Small End A'	Length of Gage Line to End L	Depth of Gaging-Notch, Plug Gage; L'
			Class X Gage	Class Y Gage	Class Z Gage			
0.239	0.50200	0.23922	0.00004	0.00007	0.00010	0.20000	0.94	0.048
0.299	0.50200	0.29968	0.00004	0.00007	0.00010	0.25000	1.19	0.048
0.375	0.50200	0.37525	0.00004	0.00007	0.00010	0.31250	1.50	0.048
1	0.59858	0.47500	0.00004	0.00007	0.00010	0.36900	2.13	0.040
2	0.59941	0.70000	0.00004	0.00007	0.00010	0.57200	2.56	0.040
3	0.60235	0.93800	0.00006	0.00009	0.00012	0.77600	3.19	0.040
4	0.62326	1.22100	0.00006	0.00009	0.00012	1.02000	4.06	0.038
4½	0.62400	1.50000	0.00006	0.00009	0.00012	1.26600	4.50	0.038
5	0.63151	1.74800	0.00008	0.00012	0.00016	1.47500	5.19	0.038
6	0.62565	2.49400	0.00008	0.00012	0.00016	2.11600	7.25	0.038
7	0.63400	3.27000	0.00010	0.00015	0.00020	2.75000	10.00	0.038
200	0.75000	2.00000	0.00008	0.00012	0.00016	1.703	4.75	0.032
250	0.75000	2.50000	0.00008	0.00012	0.00016	2.156	5.50	0.032
300	0.75000	3.00000	0.00010	0.00015	0.00020	2.609	6.25	0.032
350	0.75000	3.50000	0.00010	0.00015	0.00020	3.063	7.00	0.032
400	0.75000	4.00000	0.00010	0.00015	0.00020	3.516	7.75	0.032
450	0.75000	4.50000	0.00010	0.00015	0.00020	3.969	8.50	0.032
500	0.75000	5.00000	0.00013	0.00019	0.00025	4.422	9.25	0.032
600	0.75000	6.00000	0.00013	0.00019	0.00025	5.328	10.75	0.032
800	0.75000	8.00000	0.00016	0.00024	0.00032	7.141	13.75	0.032
1000	0.75000	10.00000	0.00020	0.00030	0.00040	8.953	16.75	0.032
1200	0.75000	12.00000	0.00020	0.00030	0.00040	10.766	19.75	0.032

<sup>a</sup>The taper per foot and diameter A at gage line are basic dimensions. Dimensions in Column A' are calculated for reference only.

<sup>b</sup>Tolerances for diameter A are plus for plug gages and minus for ring gages.

All dimensions are in inches.

The amount of taper deviation for Class X, Class Y, and Class Z gages are the same, respectively, as the amounts shown for tolerances on diameter A. Taper deviation is the permissible allowance from true taper at any point of diameter in the length of the gage. On taper *plug* gages, this deviation may be applied only in the direction which *decreases* the rate of taper. On taper *ring* gages, this deviation may be applied only in the direction which *increases* the rate of taper. Tolerances on two-decimal dimensions are  $\pm 0.010$ .

**British Standard Tapers.**—British Standard 1660: 1972, "Machine Tapers, Reduction Sleeves, and Extension Sockets," contains dimensions for self-holding and self-releasing tapers, reduction sleeves, extension sockets, and turret sockets for tools having Morse and metric 5 per cent taper shanks. Adapters for use with  $7/8$  tapers and dimensions for spindle noses and tool shanks with self-release tapers and cotter slots are included in this Standard.

Table 8. Dimensions of Morse Taper Sleeves

A	B	C	D	E	F	G	H	I	K	L	M
2	1	3 <sup>1</sup> / <sub>16</sub>	0.700	3 <sup>1</sup> / <sub>8</sub>	1 <sup>1</sup> / <sub>2</sub>	1 <sup>1</sup> / <sub>16</sub>	2 <sup>3</sup> / <sub>16</sub>	0.475	2 <sup>1</sup> / <sub>16</sub>	3 <sup>1</sup> / <sub>4</sub>	0.213
3	1	3 <sup>5</sup> / <sub>16</sub>	0.938	1 <sup>1</sup> / <sub>4</sub>	5 <sup>1</sup> / <sub>16</sub>	5 <sup>1</sup> / <sub>16</sub>	2 <sup>3</sup> / <sub>16</sub>	0.475	2 <sup>1</sup> / <sub>16</sub>	3 <sup>1</sup> / <sub>4</sub>	0.213
3	2	4 <sup>1</sup> / <sub>16</sub>	0.938	3 <sup>1</sup> / <sub>2</sub>	5 <sup>1</sup> / <sub>16</sub>	5 <sup>1</sup> / <sub>16</sub>	2 <sup>3</sup> / <sub>16</sub>	0.700	2 <sup>1</sup> / <sub>16</sub>	7 <sup>1</sup> / <sub>8</sub>	0.260
4	1	4 <sup>7</sup> / <sub>16</sub>	1.231	1 <sup>1</sup> / <sub>2</sub>	1 <sup>1</sup> / <sub>2</sub>	5 <sup>1</sup> / <sub>16</sub>	2 <sup>3</sup> / <sub>16</sub>	0.475	2 <sup>1</sup> / <sub>16</sub>	3 <sup>1</sup> / <sub>4</sub>	0.213
4	2	4 <sup>7</sup> / <sub>16</sub>	1.231	1 <sup>1</sup> / <sub>2</sub>	1 <sup>1</sup> / <sub>2</sub>	5 <sup>1</sup> / <sub>16</sub>	2 <sup>3</sup> / <sub>16</sub>	0.700	2 <sup>1</sup> / <sub>16</sub>	7 <sup>1</sup> / <sub>8</sub>	0.260
4	3	5 <sup>1</sup> / <sub>8</sub>	1.231	3 <sup>1</sup> / <sub>4</sub>	1 <sup>1</sup> / <sub>2</sub>	5 <sup>1</sup> / <sub>16</sub>	3 <sup>1</sup> / <sub>4</sub>	0.938	3 <sup>1</sup> / <sub>16</sub>	1 <sup>3</sup> / <sub>16</sub>	0.322
5	1	6 <sup>1</sup> / <sub>8</sub>	1.748	1 <sup>1</sup> / <sub>2</sub>	5 <sup>1</sup> / <sub>16</sub>	3 <sup>1</sup> / <sub>4</sub>	2 <sup>3</sup> / <sub>16</sub>	0.475	2 <sup>1</sup> / <sub>16</sub>	3 <sup>1</sup> / <sub>4</sub>	0.213
5	2	6 <sup>1</sup> / <sub>8</sub>	1.748	1 <sup>1</sup> / <sub>2</sub>	5 <sup>1</sup> / <sub>16</sub>	3 <sup>1</sup> / <sub>4</sub>	2 <sup>3</sup> / <sub>16</sub>	0.700	2 <sup>1</sup> / <sub>16</sub>	7 <sup>1</sup> / <sub>8</sub>	0.260
5	3	6 <sup>1</sup> / <sub>8</sub>	1.748	1 <sup>1</sup> / <sub>2</sub>	5 <sup>1</sup> / <sub>16</sub>	3 <sup>1</sup> / <sub>4</sub>	3 <sup>1</sup> / <sub>4</sub>	0.938	3 <sup>1</sup> / <sub>16</sub>	1 <sup>3</sup> / <sub>16</sub>	0.322
5	4	6 <sup>1</sup> / <sub>8</sub>	1.748	3 <sup>1</sup> / <sub>4</sub>	5 <sup>1</sup> / <sub>16</sub>	3 <sup>1</sup> / <sub>4</sub>	4 <sup>1</sup> / <sub>8</sub>	1.231	3 <sup>1</sup> / <sub>16</sub>	1 <sup>1</sup> / <sub>4</sub>	0.478
6	1	8 <sup>1</sup> / <sub>8</sub>	2.494	3 <sup>1</sup> / <sub>8</sub>	3 <sup>1</sup> / <sub>4</sub>	1 <sup>1</sup> / <sub>8</sub>	2 <sup>3</sup> / <sub>16</sub>	0.475	2 <sup>1</sup> / <sub>16</sub>	3 <sup>1</sup> / <sub>4</sub>	0.213
6	2	8 <sup>1</sup> / <sub>8</sub>	2.494	3 <sup>1</sup> / <sub>8</sub>	3 <sup>1</sup> / <sub>4</sub>	1 <sup>1</sup> / <sub>8</sub>	2 <sup>3</sup> / <sub>16</sub>	0.700	2 <sup>1</sup> / <sub>16</sub>	7 <sup>1</sup> / <sub>8</sub>	0.260
6	3	8 <sup>1</sup> / <sub>8</sub>	2.494	3 <sup>1</sup> / <sub>8</sub>	3 <sup>1</sup> / <sub>4</sub>	1 <sup>1</sup> / <sub>8</sub>	3 <sup>1</sup> / <sub>4</sub>	0.938	3 <sup>1</sup> / <sub>16</sub>	1 <sup>3</sup> / <sub>16</sub>	0.322
6	4	8 <sup>1</sup> / <sub>8</sub>	2.494	3 <sup>1</sup> / <sub>8</sub>	3 <sup>1</sup> / <sub>4</sub>	1 <sup>1</sup> / <sub>8</sub>	4 <sup>1</sup> / <sub>8</sub>	1.231	3 <sup>1</sup> / <sub>16</sub>	1 <sup>1</sup> / <sub>4</sub>	0.478
6	5	8 <sup>1</sup> / <sub>8</sub>	2.494	3 <sup>1</sup> / <sub>8</sub>	3 <sup>1</sup> / <sub>4</sub>	1 <sup>1</sup> / <sub>8</sub>	5 <sup>1</sup> / <sub>8</sub>	1.748	4 <sup>1</sup> / <sub>16</sub>	1 <sup>1</sup> / <sub>2</sub>	0.635
7	3	11 <sup>1</sup> / <sub>8</sub>	3.270	3 <sup>1</sup> / <sub>8</sub>	1 <sup>1</sup> / <sub>2</sub>	1 <sup>1</sup> / <sub>8</sub>	3 <sup>1</sup> / <sub>4</sub>	0.938	3 <sup>1</sup> / <sub>16</sub>	1 <sup>3</sup> / <sub>16</sub>	0.322
7	4	11 <sup>1</sup> / <sub>8</sub>	3.270	3 <sup>1</sup> / <sub>8</sub>	1 <sup>1</sup> / <sub>2</sub>	1 <sup>1</sup> / <sub>8</sub>	4 <sup>1</sup> / <sub>8</sub>	1.231	3 <sup>1</sup> / <sub>16</sub>	1 <sup>1</sup> / <sub>4</sub>	0.478
7	5	11 <sup>1</sup> / <sub>8</sub>	3.270	3 <sup>1</sup> / <sub>8</sub>	1 <sup>1</sup> / <sub>2</sub>	1 <sup>1</sup> / <sub>8</sub>	5 <sup>1</sup> / <sub>8</sub>	1.748	4 <sup>1</sup> / <sub>16</sub>	1 <sup>1</sup> / <sub>2</sub>	0.635
7	6	12 <sup>1</sup> / <sub>8</sub>	3.270	1 <sup>1</sup> / <sub>4</sub>	1 <sup>1</sup> / <sub>2</sub>	1 <sup>1</sup> / <sub>8</sub>	7 <sup>1</sup> / <sub>8</sub>	2.494	7	1 <sup>1</sup> / <sub>4</sub>	0.760

Table 9. Morse Taper Sockets — Hole and Shank Sizes

Size	Morse Taper		Size	Morse Taper		Size	Morse Taper	
	Hole	Shank		Hole	Shank		Hole	Shank
1 by 2	No. 1	No. 2	2 by 5	No. 2	No. 5	4 by 4	No. 4	No. 4
1 by 3	No. 1	No. 3	3 by 2	No. 3	No. 2	4 by 5	No. 4	No. 5
1 by 4	No. 1	No. 4	3 by 3	No. 3	No. 3	4 by 6	No. 4	No. 6
1 by 5	No. 1	No. 5	3 by 4	No. 3	No. 4	5 by 4	No. 5	No. 4
2 by 3	No. 2	No. 3	3 by 5	No. 3	No. 5	5 by 5	No. 5	No. 5
2 by 4	No. 2	No. 4	4 by 3	No. 4	No. 3	5 by 6	No. 5	No. 6

Table 10. Brown & Sharpe Taper Shanks

Num-ber of Taper	Taper per Foot (inch)	Dia. of Plug at Small End D	Plug Depth, P			Keyway from End of Spindle		Shank Depth	Length of Key-way <sup>a</sup>	Width of Key-way <sup>a</sup>	Length of Arbor Tongue	Diameter of Arbor Tongue		
			B & S <sup>b</sup> Standard	Mill. Standard	Miscell.	K	S					d	r	
1 <sup>c</sup>	.50200	.20000	...	...	...	1 1/16	1 1/16	3/8	.135	3/16	.170	1/8	1/8	
2 <sup>c</sup>	.50200	.25000	...	...	...	1 1/8	1 1/8	1/2	.166	1/4	.220	5/32	5/32	
3 <sup>c</sup>	.50200	.31250	...	...	1 1/4	1 3/4	1 3/4	2 1/4	3/8	.197	3/8	.282	3/8	3/8
			...	...	2	1 3/4	2 1/4	3/8	.197	3/8	.282	3/8	3/8	
4	.50240	.35000	...	1 1/4	...	1 3/4	1 3/4	2 3/8	1/2	.228	1/2	.320	1/2	1/2
			...	1 1/4	...	1 3/4	1 3/4	2 3/8	1/2	.228	1/2	.320	1/2	1/2
5	.50160	.45000	...	1 3/4	...	1 3/4	2 3/8	3/4	.260	3/4	.420	1/2	1/2	
			...	2	1 3/4	2 3/8	3/4	.260	3/4	.420	1/2	1/2		
6	.50329	.50000	...	2 1/4	...	2 1/4	2 3/8	3/4	.291	3/4	.460	3/4	3/4	
			...	2 1/4	...	2 1/4	2 3/8	3/4	.291	3/4	.460	3/4	3/4	
7	.50147	.60000	...	2 3/4	...	2 3/4	3 1/2	1 1/8	.322	1 1/8	.560	3/4	3/4	
			...	3	...	2 3/4	3 1/2	1 1/8	.322	1 1/8	.560	3/4	3/4	
8	.50100	.75000	...	3 3/4	...	3 3/4	4 1/2	1	.353	1	.710	1 1/2	1 1/2	
			...	4 3/4	...	4 1/2	4 1/2	1 1/8	.385	1 1/8	.860	3/4	3/4	
9	.50085	.90010	...	4 3/4	...	4 3/4	5 3/8	1 1/8	.447	1 1/8	1.010	1 1/4	1 1/4	
			...	5	...	4 3/4	5 3/8	1 1/8	.447	1 1/8	1.010	1 1/4	1 1/4	
10	.51612	1.04465	...	5 1/4	...	5 1/4	6 1/2	1 3/8	.447	1 3/8	1.010	1 1/4	1 1/4	
			...	5 1/4	...	5 1/4	6 1/2	1 3/8	.447	1 3/8	1.010	1 1/4	1 1/4	
11	.50100	1.24995	...	6 1/4	...	6 1/4	7 1/2	1 3/8	.447	1 3/8	1.210	1 1/4	1 1/4	
			...	6 1/4	...	6 1/4	7 1/2	1 3/8	.447	1 3/8	1.210	1 1/4	1 1/4	
12	.49973	1.50010	...	7 1/4	...	7 1/4	8 1/2	1 3/8	.510	1 3/8	1.460	1 1/2	1 1/2	
			...	7 1/4	...	7 1/4	8 1/2	1 3/8	.510	1 3/8	1.460	1 1/2	1 1/2	
13	.50020	1.75005	...	8 1/4	...	8 1/4	9 1/2	1 3/8	.572	1 3/8	1.960	1 1/2	1 1/2	
			...	8 1/4	...	8 1/4	9 1/2	1 3/8	.572	1 3/8	1.960	1 1/2	1 1/2	
14	.50000	2.00000	...	8 3/4	...	8 3/4	9 3/4	1 3/8	.572	1 3/8	2.210	1 1/2	1 1/2	
			...	8 3/4	...	8 3/4	9 3/4	1 3/8	.572	1 3/8	2.210	1 1/2	1 1/2	
15	.50000	2.25000	...	9 1/4	...	9 1/4	10 1/4	1 3/8	.635	1 3/8	2.450	1 1/2	1 1/2	
			...	9 1/4	...	9 1/4	10 1/4	1 3/8	.635	1 3/8	2.450	1 1/2	1 1/2	
16	.50000	2.50000	...	9 3/4	...	9 3/4	...	...	...	...	...	...	...	
			...	9 3/4	...	9 3/4	...	...	...	...	...	...	...	...
17	.50000	2.75000	...	10 1/4	...	10 1/4	...	...	...	...	...	...	...	
			...	10 1/4	...	10 1/4	...	...	...	...	...	...	...	...
18	.50000	3.00000	...	10 3/4	...	10 3/4	...	...	...	...	...	...	...	
			...	10 3/4	...	10 3/4	...	...	...	...	...	...	...	...

<sup>a</sup> Special lengths of keyway are used instead of standard lengths in some places. Standard lengths need not be used when keyway is for driving only and not for admitting key to force out tool.  
<sup>b</sup> "B & S Standard" Plug Depths are not used in all cases.  
<sup>c</sup> Adopted by American Standards Association.

Table 11. Jarno Taper Shanks

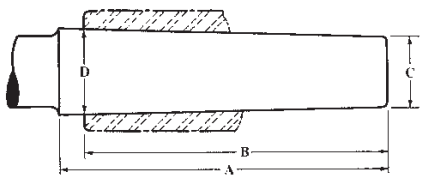

$D = \frac{\text{no. of taper}}{8}$      $C = \frac{\text{no. of taper}}{10}$      $B = \frac{\text{no. of taper}}{2}$

Number of Taper	Length A	Length B	Diameter C	Diameter D	Taper per foot
2	1 $\frac{1}{8}$	1	0.20	0.250	0.600
3	1 $\frac{3}{8}$	1 $\frac{1}{2}$	0.30	0.375	0.600
4	2 $\frac{1}{8}$	2	0.40	0.500	0.600
5	2 $\frac{1}{2}$	2 $\frac{1}{2}$	0.50	0.625	0.600
6	3 $\frac{1}{8}$	3	0.60	0.750	0.600
7	3 $\frac{1}{2}$	3 $\frac{1}{2}$	0.70	0.875	0.600
8	4 $\frac{1}{8}$	4	0.80	1.000	0.600
9	4 $\frac{1}{2}$	4 $\frac{1}{2}$	0.90	1.125	0.600
10	5 $\frac{1}{4}$	5	1.00	1.250	0.600
11	5 $\frac{3}{8}$	5 $\frac{1}{2}$	1.10	1.375	0.600
12	6 $\frac{1}{4}$	6	1.20	1.500	0.600
13	6 $\frac{3}{8}$	6 $\frac{1}{2}$	1.30	1.625	0.600
14	7 $\frac{1}{4}$	7	1.40	1.750	0.600
15	7 $\frac{3}{8}$	7 $\frac{1}{2}$	1.50	1.875	0.600
16	8 $\frac{1}{8}$	8	1.60	2.000	0.600
17	8 $\frac{3}{8}$	8 $\frac{1}{2}$	1.70	2.125	0.600
18	9 $\frac{1}{8}$	9	1.80	2.250	0.600
19	9 $\frac{3}{8}$	9 $\frac{1}{2}$	1.90	2.375	0.600
20	10 $\frac{1}{8}$	10	2.00	2.500	0.600

**Tapers for Machine Tool Spindles.**—Most lathe spindles have Morse tapers, most milling machine spindles have American Standard tapers, almost all smaller milling machine spindles have R8 tapers, and large vertical milling machine spindles have American Standard tapers. The spindles of drilling machines and the taper shanks of twist drills are made to fit the Morse taper. For lathes, the Morse taper is generally used, but lathes may have the Jarno, Brown & Sharpe, or a special taper. Of 33 lathe manufacturers, 20 use the Morse taper; 5, the Jarno; 3 use special tapers of their own; 2 use modified Morse (longer than the standard but the same taper); 2 use Reed (which is a short Jarno); 1 uses the Brown & Sharpe standard. For grinding machine centers, Jarno, Morse, and Brown & Sharpe tapers are used. Of ten grinding machine manufacturers, 3 use Brown & Sharpe; 3 use Morse; and 4 use Jarno. The Brown & Sharpe taper is used extensively for milling machine and dividing head spindles. The standard milling machine spindle adopted in 1927 by the milling machine manufacturers of the National Machine Tool Builders' Association (now The Association for Manufacturing Technology [AMT]), has a taper of 3 $\frac{1}{2}$  inches per foot. This comparatively steep taper was adopted to ensure easy release of arbors.



Table 12. American National Standard Plug and Ring Gages for Steep Machine Tapers ANSI/ASME B5.10-1994

No. of Taper	Taper per Foot <sup>a</sup> (Basic)	Diameter at Gage Line <sup>a</sup> A	Tolerances for Diameter A <sup>b</sup>			Diameter at Small End <sup>a</sup> A'	Length Gage Line to Small End L	Overall Length of Gage Body B	Dia. of Opening C
			Class X Gage	Class Y Gage	Class Z Gage				
5	3.500	0.500	0.00004	0.00007	0.00010	0.2995	0.6875	0.81	0.30
10	3.500	0.625	0.00004	0.00007	0.00010	0.3698	0.8750	1.00	0.36
15	3.500	0.750	0.00004	0.00007	0.00010	0.4401	1.0625	1.25	0.44
20	3.500	0.875	0.00006	0.00009	0.00012	0.4922	1.3125	1.50	0.48
25	3.500	1.000	0.00006	0.00009	0.00012	0.5443	1.5625	1.75	0.53
30	3.500	1.250	0.00006	0.00009	0.00012	0.7031	1.8750	2.06	0.70
35	3.500	1.500	0.00006	0.00009	0.00012	0.8438	2.2500	2.44	0.84
40	3.500	1.750	0.00008	0.00012	0.00016	1.0026	2.5625	2.75	1.00
45	3.500	2.250	0.00008	0.00012	0.00016	1.2839	3.3125	3.50	1.00
50	3.500	2.750	0.00010	0.00015	0.00020	1.5833	4.0000	4.25	1.00
55	3.500	3.500	0.00010	0.00015	0.00020	1.9870	5.1875	5.50	1.00
60	3.500	4.250	0.00010	0.00015	0.00020	2.3906	6.3750	6.75	2.00

<sup>a</sup> The taper per foot and diameter A at gage line are basic dimensions. Dimensions in Column A' are calculated for reference only.

<sup>b</sup> Tolerances for diameter A are plus for plug gages and minus for ring gages.

All dimensions are in inches.

The amounts of taper deviation for Class X, Class Y, and Class Z gages are the same, respectively, as the amounts shown for tolerances on diameter A. Taper deviation is the permissible allowance from true taper at any point of diameter in the length of the gage. On taper *plug* gages, this deviation may be applied only in the direction which *decreases* the rate of taper. On taper *ring* gages, this deviation may be applied only in the direction which *increases* the rate of taper. Tolerances on two-decimal dimensions are ±0.010.

Table 13. Jacobs Tapers and Threads for Drill Chucks and Spindles

Taper Series	A	B	C	Taper per Ft.	Taper Series	A	B	C	Taper per Ft.
No. 0	0.2590	0.22844	0.43750	0.59145	No. 4	1.1240	1.0372	1.6563	0.62886
No. 1	0.3840	0.33341	0.65625	0.92508	No. 5	1.4130	1.3161	1.8750	0.62010
No. 2	0.5590	0.48764	0.87500	0.97861	No. 6	0.6760	0.6241	1.0000	0.62292
No. 2 <sup>a</sup>	0.5488	0.48764	0.75000	0.97861	No. 33	0.6240	0.5605	1.0000	0.76194
No. 3	0.8110	0.74610	1.21875	0.63898	...	...	...	...	...

<sup>a</sup>These dimensions are for the No. 2 "short" taper.

Thread Size	Diameter D		Diameter E		Dimension F	
	Max.	Min.	Max.	Min.	Max.	Min.
5/16-24	0.531	0.516	0.3245	0.3195	0.135	0.115
3/8-24	0.633	0.618	0.3245	0.3195	0.135	0.115
1/2-24	0.633	0.618	0.385	0.380	0.135	0.115
5/8-20	0.860	0.845	0.510	0.505	0.135	0.115
3/4-11	1.125	1.110	0.635	0.630	0.166	0.146
7/8-16	1.125	1.110	0.635	0.630	0.166	0.146
1-16	1.250	1.235	0.713	0.708	0.166	0.146
1 1/8-16	1.250	1.235	0.760	0.755	0.166	0.146
1-8	1.437	1.422	1.036	1.026	0.281	0.250
1-10	1.437	1.422	1.036	1.026	0.281	0.250
1 1/2-8	1.871	1.851	1.536	1.526	0.343	0.312

Thread <sup>a</sup> Size	G		I <sup>b</sup>	Plug Gage Pitch Dia.		Ring Gage Pitch Dia.	
	Max	Min		Go	Not Go	Go	Not Go
5/16-24	0.3114	0.3042	0.437 <sup>c</sup>	0.2854	0.2902	0.2843	0.2806
3/8-24	0.3739	0.3667	0.562 <sup>c</sup>	0.3479	0.3528	0.3468	0.3430
1/2-20	0.4987	0.4906	0.562	0.4675	0.4731	0.4662	0.4619
5/8-11	0.6234	0.6113	0.687	0.5660	0.5732	0.5644	0.5589
3/4-16	0.6236	0.6142	0.687	0.5844	0.5906	0.5830	0.5782
7/8-16	0.7016	0.6922	0.687	0.6625	0.6687	0.6610	0.6561
1-16	0.7485	0.7391	0.687	0.7094	0.7159	0.7079	0.7029
1-8	1.000	0.9848	1.000	0.9188	0.9242	0.9188	0.9134
1-10	1.000	0.9872	1.000	0.9350	0.9395	0.9350	0.9305
1 1/2-8	1.500	1.4848	1.000	1.4188	1.4242	1.4188	1.4134

<sup>a</sup>Except for 1-8, 1-10, 1 1/2-8 all threads are now manufactured to the American National Standard Unified Screw Thread System, Internal Class 2B, External Class 2A. Effective date 1976.

<sup>b</sup>Tolerances for dimension H are as follows: 0.030 inch for thread sizes 5/16-24 to 3/4-16, inclusive and 0.125 inch for thread sizes 1-8 to 1 1/2-8, inclusive.

<sup>c</sup>Length for Jacobs 0B5/16 chuck is 0.375 inch, length for 1B5/16 chuck is 0.437 inch.

<sup>d</sup>Length for Jacobs No. 1B5 chuck is 0.437 inch.

*Usual Chuck Capacities for Different Taper Series Numbers:* No. 0 taper, drill diameters, 0-5/32 inch; No. 1, 0-1/4 inch; No. 2, 0-1/2 inch; No. 2 "Short," 0-3/16 inch; No. 3, 0-1/2, 1/8-3/8, 3/16-3/4, or 1/4-13/16 inch; No. 4, 1/8-3/4 inch; No. 5, 3/8-1; No. 6, 0-1/2 inch; No. 33, 0-1/2 inch.

*Usual Chuck Capacities for Different Thread Sizes:* Size 5/16-24, drill diameters 0-1/4 inch; size 3/8-24, drill diameters 0-3/8, 1/16-3/8, or 3/64-1/2 inch; size 1/2-20, drill diameters 0-1/2, 1/16-3/8, or 3/64-1/2 inch; size 5/8-11, drill diameters 0-1/2 inch; size 3/4-16, drill diameters 0-1/2, 1/8-3/8, or 3/16-3/4 inch; size 7/8-16, drill diameters 0-1/2 inch; size 1-16, drill diameters 0-1/2 or 3/16-3/4.

Table 1. Essential Dimensions of American National Standard Spindle Noses for Milling Machines ANSI B5.18-1972 (R1998)

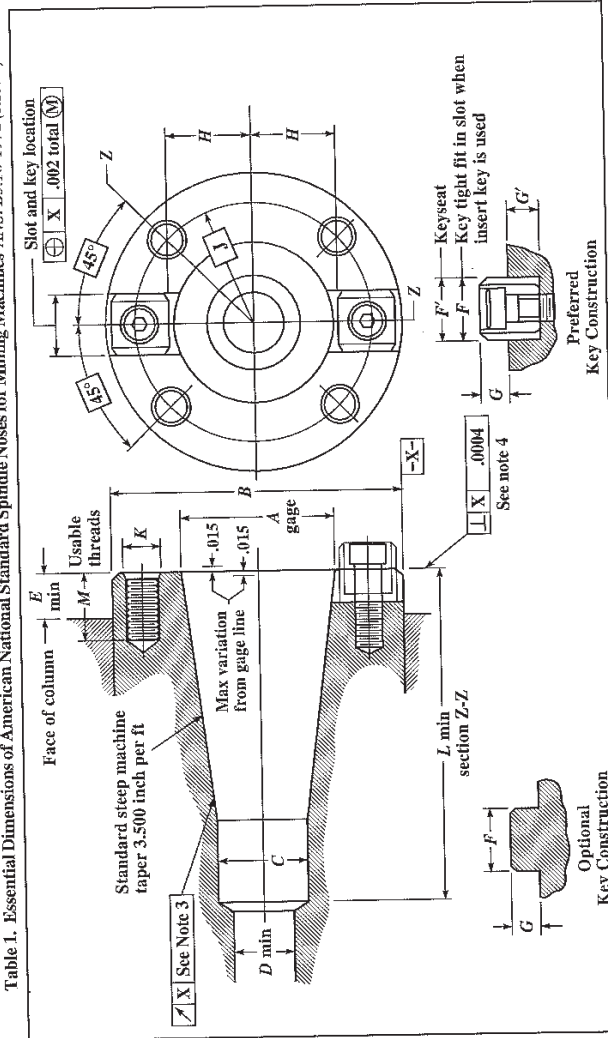

Table 1. (Continued) Essential Dimensions of American National Standard Spindle Noses for Milling Machines ANSIBS-18-1972 (R1998)

Size No.	Cone Dia of Taper A	Dia of Spindle B	Plat Dia C	Clearance Between Dowel and Bolt Min. D	Minimum Dimension Spindle Lead to Column E	Width of Driving Key F	Width of Keyway F	Minimum Depth of Driving Key G	Minimum Depth of Keyseat G	Distance from Key to Driving Keys H	Radius of Hole in Circle J	Size of Thread Holes UNC-2B K	Full Depth of Hole in Spindle Min. L	Depth of U-Channel for Bolt Hole M
30	1.230	2.7493 2.7488	0.692 0.685	0.66	0.50	0.6255 0.6252	0.624 0.625	0.31	0.31	0.660 0.654	1.0625 (Note 1)	0.375-16	2.88	0.62
40	1.750	3.4993 3.4988	1.005 0.997	0.66	0.62	0.6255 0.6252	0.624 0.625	0.31	0.31	0.910 0.904	1.3125 (Note 1)	0.500-13	3.88	0.81
45	2.250	3.9993 3.9988	1.286 1.278	0.78	0.62	0.7505 0.7502	0.749 0.750	0.38	0.38	1.160 1.154	1.500 (Note 1)	0.500-13	4.75	0.81
50	2.750	5.0618 5.0613	1.568 1.559	1.06	0.75	1.0006 1.0002	0.999 1.000	0.50	0.50	1.410 1.404	2.0000 Note 2)	0.625-11	5.50	1.00
60	4.250	8.7180 8.7175	2.381 2.371	1.38	1.50	1.0006 1.0002	0.999 1.000	0.50	0.50	2.420 2.414	3.500 (Note 2)	0.750-10	8.62	1.25

All dimensions are given in inches.

Tolerances:

Two-digit decimal dimensions  $\pm 0.010$  unless otherwise specified.

A—Taper: Tolerance on rate of taper to be 0.001 inch per foot applied only in direction which decreases rate of taper.

F—Centrality of keyway with axis of taper 0.002 total at maximum material condition, (0.002 Total indicator variation)

F—Centrality of solid key with axis of taper 0.002 total at maximum material condition, (0.002 Total indicator variation)

Note 1: Holes spaced as shown and located within 0.006 inch diameter of true position.

Note 2: Holes spaced as shown and located within 0.010 inch diameter of true position.

Note 3: Maximum turnout on test plug:

0.0004 at 1 inch projection from gage line.

0.0010 at 12 inch projection from gage line.

Note 4: Squareness of mounting face measured near mounting bolt hole circle.

Table 2. Essential Dimensions of American National Standard Tool Shanks for Milling Machines ANSI B5.18-1972, R1991

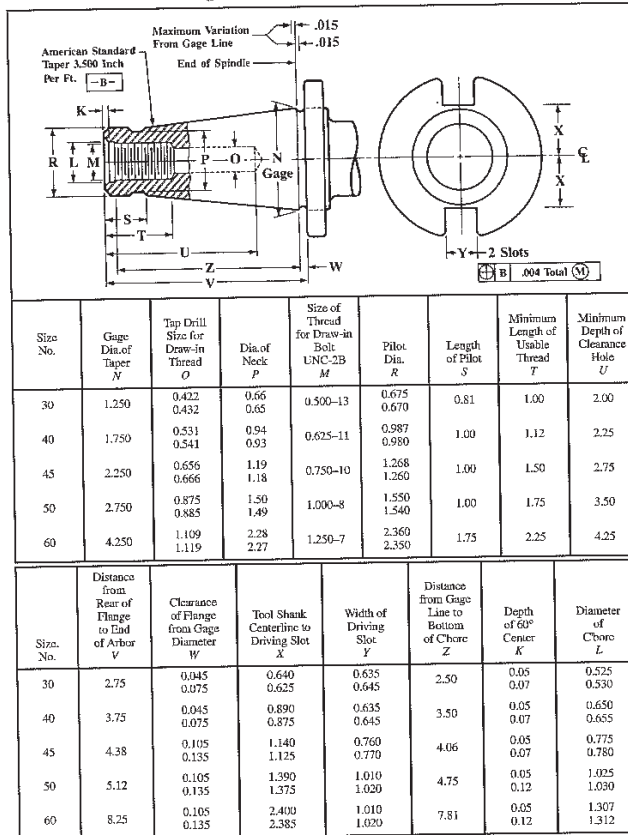

All dimensions are given in inches.

Tolerances: Two digit decimal dimensions ± 0.010 inch unless otherwise specified.

M—Permissible for Class 2B “NoGo” gage to enter five threads before interference.

N—Taper tolerance on rate of taper to be 0.001 inch per foot applied only in direction which increases rate of taper.

Y—Centrality of drive slot with axis of taper shank 0.004 inch at maximum material condition. (0.004 inch total indicator variation)

**Table 3. American National Standard Draw-in Bolt Ends**  
ANSI B5.18-1972, R1991

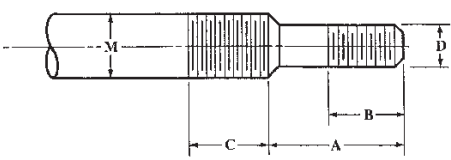

Size No.	Length of Small End A	Length of Usable Thread at Small End B	Length of Usable Thread on Large Diameter C	Size of Thread for Large End UNC-2A M	Size of Thread for Small End UNC-2A D
30	1.06	0.75	0.75	0.500-13	0.375-16
40	1.25	1.00	1.12	0.625-11	0.500-13
45	1.50	1.12	1.25	0.750-10	0.625-11
50	1.50	1.25	1.38	1.000-8	0.625-11
60	1.75	1.37	2.00	1.250-7	1.000-8

All dimensions are given in inches.

**Table 4. American National Standard Pilot Lead on Centering Plugs for Flatback Milling Cutters**  
ANSI B5.18-1972 (R1998)

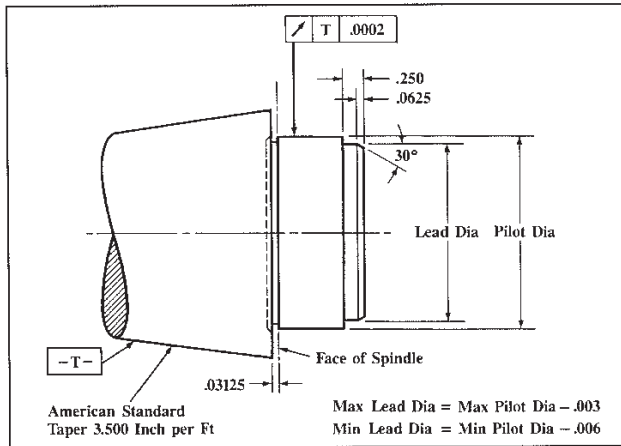
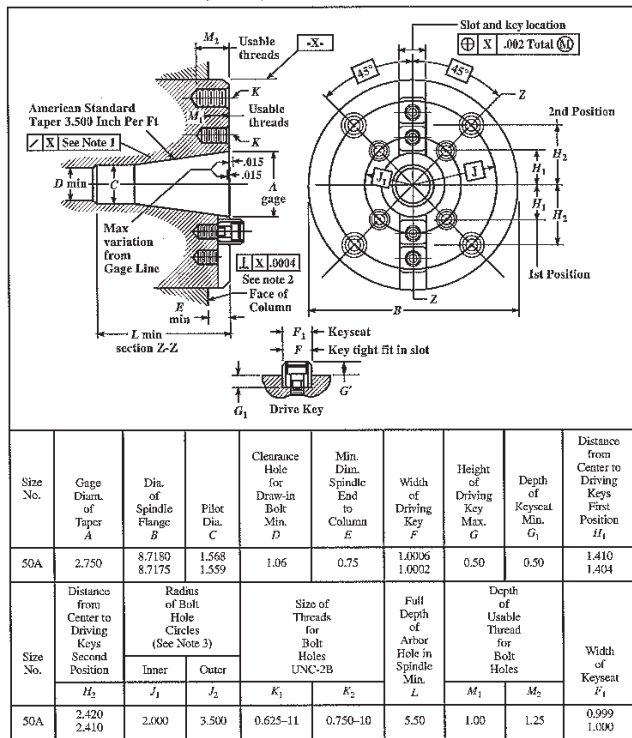

Table 5. Essential Dimensions for American National Standard Spindle Nose with Large Flange ANSI B5.18-1972 (R1998)



All dimensions are given in inches.

Tolerances: Two-digit decimal dimensions ± 0.010 unless otherwise specified.

A—Tolerance on rate of taper to be 0.001 inch per foot applied only in direction which decreases rate of taper.

F—Centrality of solid key with axis of taper 0.002 inch total at maximum material condition. (0.002 inch Total indicator variation)

F<sub>1</sub>—Centrality of keyseat with axis of taper 0.002 inch total at maximum material condition. (0.002 inch Total indicator variation)

Note 1: Maximum runout on test plug: 0.0004 at 1 inch projection from gage line. 0.0010 at 12 inch projection from gage line.

Note 2: Squareness of mounting face measured near mounting bolt hole circle.

Note 3: Holes located as shown and within 0.010 inch diameter of true position.

STANDARD TAPERS

925

Length of Point on Twist Drills and Centering Tools

Size of Drill	Decimal Equivalent	Length of Point when Included Angle = 90°	Size of Drill	Decimal Equivalent	Length of Point when Included Angle = 90°	Length of Point when Included Angle = 118°	Size of Drill	Decimal Equivalent	Length of Point when Included Angle = 118°	Length of Point when Included Angle = 90°	Decimal Equivalent	Length of Point when Included Angle = 90°	Length of Point when Included Angle = 118°	Decimal Equivalent	Length of Point when Included Angle = 118°
66	0.0400	0.020	37	0.1040	0.052	0.031	14	0.1820	0.091	0.055	0.3750	0.188	0.113		
59	0.0410	0.021	36	0.1065	0.054	0.032	13	0.1850	0.093	0.055	0.3906	0.185	0.117		
58	0.0420	0.021	35	0.1100	0.055	0.033	12	0.1890	0.095	0.057	0.4063	0.203	0.122		
57	0.0430	0.022	34	0.1110	0.056	0.033	11	0.1910	0.096	0.057	0.4219	0.211	0.127		
56	0.0465	0.023	33	0.1130	0.057	0.034	10	0.1935	0.097	0.058	0.4375	0.219	0.131		
55	0.0520	0.026	32	0.1160	0.058	0.035	9	0.1960	0.098	0.059	0.4531	0.227	0.136		
54	0.0550	0.028	31	0.1200	0.060	0.036	8	0.1990	0.100	0.060	0.4688	0.234	0.141		
53	0.0595	0.030	30	0.1260	0.063	0.037	7	0.2010	0.101	0.060	0.5000	0.250	0.150		
52	0.0635	0.032	29	0.1285	0.064	0.038	6	0.2040	0.102	0.061	0.5156	0.258	0.155		
51	0.0670	0.034	28	0.1405	0.070	0.042	5	0.2055	0.103	0.062	0.5313	0.266	0.159		
50	0.0700	0.035	27	0.1440	0.072	0.043	4	0.2090	0.105	0.063	0.5469	0.273	0.164		
49	0.0730	0.037	26	0.1470	0.074	0.044	3	0.2130	0.107	0.064	0.5625	0.281	0.169		
48	0.0760	0.038	25	0.1495	0.075	0.045	2	0.2210	0.111	0.067	0.5781	0.289	0.173		
47	0.0785	0.040	24	0.1520	0.076	0.046	1	0.2280	0.114	0.068	0.5938	0.297	0.178		
46	0.0810	0.041	23	0.1540	0.077	0.046	3/4	0.2344	0.117	0.070	0.6094	0.305	0.183		
45	0.0820	0.041	22	0.1570	0.079	0.047	1/2	0.2500	0.125	0.075	0.6250	0.313	0.188		
44	0.0860	0.043	21	0.1590	0.080	0.048	3/8	0.2656	0.133	0.080	0.6406	0.320	0.192		
43	0.0890	0.045	20	0.1610	0.081	0.048	5/16	0.2813	0.141	0.084	0.6563	0.328	0.197		
42	0.0935	0.047	19	0.1660	0.083	0.050	3/8	0.2969	0.148	0.089	0.6719	0.336	0.202		
41	0.0960	0.048	18	0.1695	0.085	0.051	1/2	0.3125	0.156	0.094	0.6875	0.344	0.206		
40	0.0980	0.049	17	0.1730	0.087	0.052	5/16	0.3281	0.164	0.098	0.7031	0.352	0.210		
39	0.0995	0.050	16	0.1770	0.089	0.053	3/4	0.3438	0.171	0.103	0.7188	0.359	0.215		
38	0.1015	0.051	15	0.1800	0.090	0.054	3/4	0.3594	0.180	0.108	0.7350	0.375	0.225		



**BROACHES AND BROACHING**

**The Broaching Process.**—The broaching process may be applied in machining holes or other internal surfaces and also to many flat or other external surfaces. Internal broaching is applied in forming either symmetrical or irregular holes, grooves, or slots in machine parts, especially when the size or shape of the opening, or its length in proportion to diameter or width, make other machining processes impracticable. Broaching originally was utilized for such work as cutting keyways, machining round holes into square, hexagonal, or other shapes, forming splined holes, and for a large variety of other internal operations. The development of broaching machines and broaches finally resulted in extensive application of the process to external, flat, and other surfaces. Most external or surface broaching is done on machines of vertical design, but horizontal machines are also used for some classes of work. The broaching process is very rapid, accurate, and it leaves a finish of good quality. It is employed extensively in automotive and other plants where duplicate parts must be produced in large quantities and frequently to given dimensions within small tolerances.

**Types of Broaches.**—A number of typical broaches and the operations for which they are intended are shown by the diagrams, Fig. 1. Broach *A* produces a round-cornered, square hole. Prior to broaching square holes, it is usually the practice to drill a round hole having a diameter  $d$  somewhat larger than the width of the square. Hence, the sides are not completely finished, but this unfinished part is not objectionable in most cases. In fact, this clearance space is an advantage during the broaching operation in that it serves as a channel for the broaching lubricant; moreover, the broach has less metal to remove. Broach *B* is for finishing round holes. Broaching is superior to reaming for some classes of work, because the broach will hold its size for a much longer period, thus insuring greater accuracy. Broaches *C* and *D* are for cutting single and double keyways, respectively. Broach *C* is of rectangular section and, when in use, slides through a guiding bushing which is inserted in the hole. Broach *E* is for forming four integral splines in a hub. The broach at *F* is for producing hexagonal holes. Rectangular holes are finished by broach *G*. The teeth on the sides of this broach are inclined in opposite directions, which has the following advantages: The broach is stronger than it would be if the teeth were opposite and parallel to each other; thin work cannot drop between the inclined teeth, as it tends to do when the teeth are at right angles, because at least two teeth are always cutting; the inclination in opposite directions neutralizes the lateral thrust. The teeth on the edges are staggered, the teeth on one side being midway between the teeth on the other edge, as shown by the dotted line. A double cut broach is shown at *H*. This type is for finishing, simultaneously, both sides of a slot, and for similar work. Broach *I* is the style used for forming the teeth in internal gears. It is practically a series of gear-shaped cutters, the outside diameters of which gradually increase toward the finishing end of the broach. Broach *J* is for round holes but differs from style *B* in that it has a continuous helical cutting edge. Some prefer this form because it gives a shearing cut. Broach *K* is for cutting a series of helical grooves in a hub or bushing. In helical broaching, either the work or the broach is rotated to form the helical grooves as the broach is pulled through.

In addition to the typical broaches shown in Fig. 1, many special designs are now in use for performing more complex operations. Two surfaces on opposite sides of a casting or forging are sometimes machined simultaneously by twin broaches and, in other cases, three or four broaches are drawn through a part at the same time, for finishing as many duplicate holes or surfaces. Notable developments have been made in the design of broaches for external or "surface" broaching.

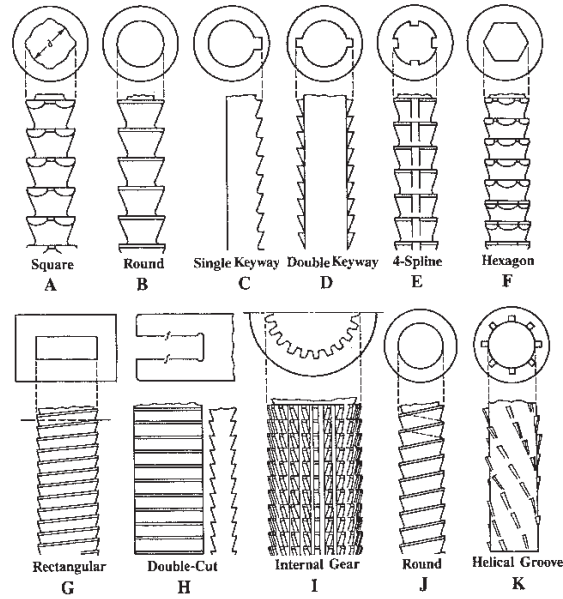

Fig. 1. Types of Broaches

**Pitch of Broach Teeth.**—The pitch of broach teeth depends upon the depth of cut or chip thickness, length of cut, the cutting force required and power of the broaching machine. In the pitch formulas which follow

$L$  = length, in inches, of layer to be removed by broaching

$d$  = depth of cut per tooth as shown by Table 1 (For internal broaches,  $d$  = depth of cut as measured on one side of broach or one-half difference in diameters of successive teeth in case of a round broach)

$F$  = a factor. (For brittle types of material,  $F = 3$  or 4 for roughing teeth, and 6 for finishing teeth. For ductile types of material,  $F = 4$  to 7 for roughing teeth and 8 for finishing teeth.)

$b$  = width of inches, of layer to be removed by broaching

$P$  = pressure required in tons per square inch, of an area equal to depth of cut times width of cut, in inches (Table 2)

$T$  = usable capacity, in tons, of broaching machine = 70 per cent of maximum tonnage

Table 1. Designing Data for Surface Broaches

Material to be Broached	Depth of Cut per Tooth, Inch		Face Angle or Rake, Degrees	Clearance Angle, Degrees	
	Roughing <sup>a</sup>	Finishing		Roughing	Finishing
Steel, High Tensile Strength	0.0015-0.002	0.0005	10-12	1.5-3	0.5-1
Steel, Medium Tensile Strength	0.0025-0.005	0.0005	14-18	1.5-3	0.5-1
Cast Steel	0.0025-0.005	0.0005	10	1.53	0.5
Malleable Iron	0.0025-0.005	0.0005	7	1.5-3	0.5
Cast Iron, Soft	0.006 -0.010	0.0005	10-15	1.5-3	0.5
Cast Iron, Hard	0.003 -0.005	0.0005	5	1.5-3	0.5
Zinc Die Castings	0.005 -0.010	0.0010	12 <sup>b</sup>	5	2
Cast Bronze	0.010 -0.025	0.0005	8	0	0
Wrought Aluminum Alloys	0.005 -0.010	0.0010	15 <sup>b</sup>	3	1
Cast Aluminum Alloys	0.005 -0.010	0.0010	12 <sup>b</sup>	3	1
Magnesium Die Castings	0.010 -0.015	0.0010	20 <sup>b</sup>	3	1

<sup>a</sup> The lower depth-of-cut values for roughing are recommended when work is not very rigid, the tolerance is small, a good finish is required, or length of cut is comparatively short.

<sup>b</sup> In broaching these materials, smooth surfaces for tooth and chip spaces are especially recommended.

Table 2. Broaching Pressure *P* for Use in Pitch Formula (2)

Material to be Broached	Depth <i>d</i> of Cut per Tooth, Inch					Pressure <i>P</i> , Side-cutting Broaches
	0.024	0.010	0.004	0.002	0.001	
	Pressure <i>P</i> in Tons per Square Inch					
Steel, High Ten. Strength	...	...	...	250	312	200-.004" cut
Steel, Med. Ten. Strength	...	...	158	185	243	143-.006" cut
Cast Steel	...	...	128	158	...	115-.006" cut
Malleable Iron	...	...	108	128	...	100-.006" cut
Cast Iron	...	115	115	143	...	115-.020" cut
Cast Brass	...	50	50	...	...	.....
Brass, Hot Pressed	...	85	85	...	...	.....
Zinc Die Castings	...	70	70	...	...	.....
Cast Bronze	35	35	...	...	...	.....
Wrought Aluminum	...	70	70	...	...	.....
Cast Aluminum	...	85	85	...	...	.....
Magnesium Alloy	35	35	...	...	...	.....

The minimum pitch shown by Formula (1) is based upon the receiving capacity of the chip space. The minimum, however, should not be less than 0.2 inch unless a smaller pitch is required for exceptionally short cuts to provide at least two teeth in contact simultaneously, with the part being broached. A reduction below 0.2 inch is seldom required in surface broaching but it may be necessary in connection with internal broaching.

$$\text{Minimum pitch} = 3\sqrt{LdF} \tag{1}$$

Whether the minimum pitch may be used or not depends upon the power of the available machine. The factor *F* in the formula provides for the increase in volume as the material is broached into chips. If a broach has adjustable inserts for the finishing teeth, the pitch of the finishing teeth may be smaller than the pitch of the roughing teeth because of the smaller depth *d* of the cut. The higher value of *F* for finishing teeth prevents the pitch from becoming too small, so that the spirally curled chips will not be crowded into too small a space.

The pitch of the roughing and finishing teeth should be equal for broaches without separate inserts (notwithstanding the different values of  $d$  and  $F$ ) so that some of the finishing teeth may be ground into roughing teeth after wear makes this necessary.

$$\text{Allowable pitch} = \frac{dLbP}{T} \quad (2)$$

If the pitch obtained by Formula (2) is larger than the minimum obtained by Formula (1), this larger value should be used because it is based upon the usable power of the machine. As the notation indicates, 70 per cent of the maximum tonnage  $T$  is taken as the usable capacity. The 30 per cent reduction is to provide a margin for the increase in broaching load resulting from the gradual dulling of the cutting edges. The procedure in calculating both minimum and allowable pitches will be illustrated by an example.

*Example:* Determine pitch of broach for cast iron when  $L = 9$  inches;  $d = 0.004$ ; and  $F = 4$ .

$$\text{Minimum pitch} = 3\sqrt{9 \times 0.004 \times 4} = 1.14$$

Next, apply Formula (2). Assume that  $b = 3$  and  $T = 10$ ; for cast iron and depth  $d$  of 0.004,  $P = 115$  (Table 2). Then,

$$\text{Allowable pitch} = \frac{0.004 \times 9 \times 3 \times 115}{10} = 1.24$$

This pitch is safely above the minimum. If in this case the usable tonnage of an available machine were, say, 8 tons instead of 10 tons, the pitch as shown by Formula (2) might be increased to about 1.5 inches, thus reducing the number of teeth cutting simultaneously and, consequently, the load on the machine; or the cut per tooth might be reduced instead of increasing the pitch, especially if only a few teeth are in cutting contact, as might be the case with a short length of cut. If the usable tonnage in the preceding example were, say, 15, then a pitch of 0.84 would be obtained by Formula (2); hence the pitch in this case should not be less than the minimum of approximately 1.14 inches.

**Depth of Cut per Tooth.**—The term “depth of cut” as applied to surface or external broaches means the difference in the heights of successive teeth. This term, as applied to internal broaches for round, hexagonal or other holes, may indicate the total increase in the diameter of successive teeth; however, to avoid confusion, the term as here used means in all cases and regardless of the type of broach, the depth of cut as measured on one side.

In broaching free cutting steel, the Broaching Tool Institute recommends 0.003 to 0.006 inch depth of cut for surface broaching; 0.002 to 0.003 inch for multispline broaching; and 0.0007 to 0.0015 inch for round hole broaching. The accompanying table contains data from a German source and applies specifically to surface broaches. All data relating to depth of cut are intended as a general guide only. While depth of cut is based primarily upon the machinability of the material, some reduction from the depth thus established may be required particularly when the work supporting fixture in surface broaching is not sufficiently rigid to resist the thrust from the broaching operation. In some cases, the pitch and cutting length may be increased to reduce the thrust force. Another possible remedy in surface broaching certain classes of work is to use a side-cutting broach instead of the ordinary depth cutting type. A broach designed for side cutting takes relatively deep narrow cuts which extend nearly to the full depth required. The side cutting section is followed by teeth arranged for depth cutting to obtain the required size and surface finish on the work. In general, small tolerances in surface broaching require a reduced cut per tooth to minimize work deflection resulting from the pressure of the cut. See *Cutting Speed for Broaching* starting on page 1043 for broaching speeds.

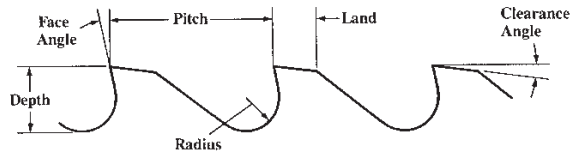

Terms Commonly Used in Broach Design

**Face Angle or Rake.**—The face angle (see diagram) of broach teeth affects the chip flow and varies considerably for different materials. While there are some variations in practice, even for the same material, the angles given in the accompanying table are believed to represent commonly used values. Some broach designers increase the rake angle for finishing teeth in order to improve the finish on the work.

**Clearance Angle.**—The clearance angle (see illustration) for roughing steel varies from 1.5 to 3 degrees and for finishing steel from 0.5 to 1 degree. Some recommend the same clearance angles for cast iron and others, larger clearance angles varying from 2 to 4 or 5 degrees. Additional data will be found in Table 1.

**Land Width.**—The width of the land usually is about  $0.25 \times$  pitch. It varies, however, from about one-fourth to one-third of the pitch. The land width is selected so as to obtain the proper balance between tooth strength and chip space.

**Depth of Broach Teeth.**—The tooth depth as established experimentally and on the basis of experience, usually varies from about 0.37 to 0.40 of the pitch. This depth is measured radially from the cutting edge to the bottom of the tooth fillet.

**Radius of Tooth Fillet.**—The "gullet" or bottom of the chip space between the teeth should have a rounded fillet to strengthen the broach, facilitate curling of the chips, and safeguard against cracking in connection with the hardening operation. One rule is to make the radius equal to one-fourth the pitch. Another is to make it equal 0.4 to 0.6 the tooth depth. A third method preferred by some broach designers is to make the radius equal one-third of the sum obtained by adding together the land width, one-half the tooth depth, and one-fourth of the pitch.

**Total Length of Broach.**—After the depth of cut per tooth has been determined, the total amount of material to be removed by a broach is divided by this decimal to ascertain the number of cutting teeth required. This number of teeth multiplied by the pitch gives the length of the active portion of the broach. By adding to this dimension the distance over three or four straight teeth, the length of a pilot to be provided at the finishing end of the broach, and the length of a shank which must project through the work and the faceplate of the machine to the draw-head, the overall length of the broach is found. This calculated length is often greater than the stroke of the machine, or greater than is practical for a broach of the diameter required. In such cases, a set of broaches must be used.

**Chip Breakers.**—The teeth of broaches frequently have rounded chip-breaking grooves located at intervals along the cutting edges. These grooves break up wide curling chips and prevent them from clogging the chip spaces, thus reducing the cutting pressure and strain on the broach. These chip-breaking grooves are on the roughing teeth only. They are staggered and applied to both round and flat or surface broaches. The grooves are formed by a round edged grinding wheel and usually vary in width from about  $\frac{1}{32}$  to  $\frac{3}{32}$  inch depending upon the size of broach. The more ductile the material, the wider the chip breaker grooves should be and the smaller the distance between them. Narrow slotting broaches may have the right- and left-hand corners of alternate teeth beveled to obtain chip-breaking action.

**Shear Angle.**—The teeth of surface broaches ordinarily are inclined so they are not at right angles to the broaching movement. The object of this inclination is to obtain a shearing cut which results in smoother cutting action and an improvement in surface finish. The shearing cut also tends to eliminate troublesome vibration. Shear angles for surface broaches are not suitable for broaching slots or any profiles that resist the outward movement of the chips. When the teeth are inclined, the fixture should be designed to resist the resulting thrusts unless it is practicable to incline the teeth of right- and left-hand sections in opposite directions to neutralize the thrust. The shear angle usually varies from 10 to 25 degrees.

**Types of Broaching Machines.**—Broaching machines may be divided into horizontal and vertical designs, and they may be classified further according to the method of operation, as, for example, whether a broach in a vertical machine is pulled up or pulled down in forcing it through the work. Horizontal machines usually pull the broach through the work in internal broaching but short rigid broaches may be pushed through. External surface broaching is also done on some machines of horizontal design, but usually vertical machines are employed for flat or other external broaching. Although parts usually are broached by traversing the broach itself, some machines are designed to hold the broach or broaches stationary during the actual broaching operation. This principle has been applied both to internal and surface broaching.

*Vertical Duplex Type:* The vertical duplex type of surface broaching machine has two slides or rams which move in opposite directions and operate alternately. While the broach connected to one slide is moving downward on the cutting stroke, the other broach and slide is returning to the starting position, and this returning time is utilized for reloading the fixture on that side; consequently, the broaching operation is practically continuous. Each ram or slide may be equipped to perform a separate operation on the same part when two operations are required.

*Pull-up Type:* Vertical hydraulically operated machines which pull the broach or broaches up through the work are used for internal broaching of holes of various shapes, for broaching bushings, splined holes, small internal gears, etc. A typical machine of this kind is so designed that all broach handling is done automatically.

*Pull-down Type:* The various movements in the operating cycle of a hydraulic pull-down type of machine equipped with an automatic broach-handling slide, are the reverse of the pull-up type. The broaches for a pull-down type of machine have shanks on each end, there being an upper one for the broach-handling slide and a lower one for pulling through the work.

*Hydraulic Operation:* Modern broaching machines, as a general rule, are operated hydraulically rather than by mechanical means. Hydraulic operation is efficient, flexible in the matter of speed adjustments, low in maintenance cost, and the "smooth" action required for fine precision finishing may be obtained. The hydraulic pressures required, which frequently are 800 to 1000 pounds per square inch, are obtained from a motor-driven pump forming part of the machine. The cutting speeds of broaching machines frequently are between 20 and 30 feet per minute, and the return speeds often are double the cutting speed, or higher, to reduce the idle period.

**Broaching Difficulties.**—The accompanying table has been compiled from information supplied by the National Broach and Machine Co. and presents some of the common broaching difficulties, their causes and means of correction.

## Causes of Broaching Difficulties

Broaching Difficulty	Possible Causes
Stuck broach	<p>Insufficient machine capacity; dulled teeth; clogged chip gullets; failure of power during cutting stroke.</p> <p>To remove a stuck broach, workpiece and broach are removed from the machine as a unit; never try to back out broach by reversing machine. If broach does not loosen by tapping workpiece lightly and trying to slide it off its starting end, mount workpiece and broach in a lathe and turn down workpiece to the tool surface. Workpiece may be sawed longitudinally into several sections in order to free the broach.</p> <p>Check broach design, perhaps tooth relief (back off) angle is too small or depth of cut per tooth is too great.</p>
Galling and pickup	<p>Lack of homogeneity of material being broached—uneven hardness, porosity; improper or insufficient coolant; poor broach design, mutilated broach; dull broach; improperly sharpened broach; improperly designed or outworn fixtures.</p> <p>Good broach design will do away with possible chip build-up on tooth faces and excessive heating. Grinding of teeth should be accurate so that the correct gullet contour is maintained. Contour should be fair and smooth.</p>
Broach breakage	<p>Overloading; broach dullness; improper sharpening; interrupted cutting stroke; backing up broach with workpiece in fixture; allowing broach to pass entirely through guide hole; ill fitting and/or sharp edged key; crooked holes; untrue locating surface; excessive hardness of workpiece; insufficient clearance angle; sharp corners on pull end of broach.</p> <p>When grinding bevels on pull end of broach use wheel that is not too pointed.</p>
Chatter	<p>Too few teeth in cutting contact simultaneously; excessive hardness of material being broached; loose or poorly constructed tooling; surging of ram due to load variations.</p> <p>Chatter can be alleviated by changing the broaching speed, by using shear cutting teeth instead of right angle teeth, and by changing the coolant and the face and relief angles of the teeth.</p>
Drifting or misalignment of tool during cutting stroke	<p>Lack of proper alignment when broach is sharpened in grinding machine, which may be caused by dirt in the female center of the broach; inadequate support of broach during the cutting stroke, on a horizontal machine especially; body diameter too small; cutting resistance variable around I.D. of hole due to lack of symmetry of surfaces to be cut; variations in hardness around I.D. of hole; too few teeth in cutting contact.</p>
Streaks in broached surface	<p>Lands too wide; presence of forging, casting or annealing scale; metal pickup; presence of grinding burrs and grinding and cleaning abrasives.</p>
Rings in the broached hole	<p>Due to surging resulting from uniform pitch of teeth; presence of sharpening burrs on broach; tooth clearance angle too large; locating face not smooth or square; broach not supported for all cutting teeth passing through the work. The use of differential tooth spacing or shear cutting teeth helps in preventing surging. Sharpening burrs on a broach may be removed with a wood block.</p>

### Tool Wear

Metal cutting tools wear constantly when they are being used. A normal amount of wear should not be a cause for concern until the size of the worn region has reached the point where the tool should be replaced. Normal wear cannot be avoided and should be differentiated from abnormal tool breakage or excessively fast wear. Tool breakage and an excessive rate of wear indicate that the tool is not operating correctly and steps should be taken to correct this situation.

There are several basic mechanisms that cause tool wear. It is generally understood that tools wear as a result of abrasion which is caused by hard particles of work material plowing over the surface of the tool. Wear is also caused by diffusion or alloying between the work material and the tool material. In regions where the conditions of contact are favorable, the work material reacts with the tool material causing an attrition of the tool material. The rate of this attrition is dependent upon the temperature in the region of contact and the reactivity of the tool and the work materials with each other. Diffusion or alloying also occurs where particles of the work material are welded to the surface of the tool. These welded deposits are often quite visible in the form of a built-up edge, as particles or a layer of work material inside a crater or as small mounds attached to the face of the tool. The diffusion or alloying occurring between these deposits and the tool weakens the tool material below the weld. Frequently these deposits are again rejoined to the chip by welding or they are simply broken away by the force of collision with the passing chip. When this happens, a small amount of the tool material may remain attached to the deposit and be plucked from the surface of the tool, to be carried away with the chip. This mechanism can cause chips to be broken from the cutting edge and the formation of small craters on the tool face called pull-outs. It can also contribute to the enlargement of the larger crater that sometimes forms behind the cutting edge. Among the other mechanisms that can cause tool wear are severe thermal gradients and thermal shocks, which cause cracks to form near the cutting edge, ultimately leading to tool failure. This condition can be caused by improper tool grinding procedures, heavy interrupted cuts, or by the improper application of cutting fluids when machining at high cutting speeds. Chemical reactions between the active constituents in some cutting fluids sometimes accelerate the rate of tool wear. Oxidation of the heated metal near the cutting edge also contributes to tool wear, particularly when fast cutting speeds and high cutting temperatures are encountered. Breakage of the cutting edge caused by overloading, heavy shock loads, or improper tool design is not normal wear and should be corrected.

The wear mechanisms described bring about visible manifestations of wear on the tool which should be understood so that the proper corrective measures can be taken, when required. These visible signs of wear are described in the following paragraphs and the corrective measures that might be required are given in the accompanying Tool Trouble-Shooting Check List. The best procedure when trouble shooting is to try to correct only one condition at a time. When a correction has been made it should be checked. After one condition has been corrected, work can then start to correct the next condition.

*Flank Wear:* Tool wear occurring on the flank of the tool below the cutting edge is called flank wear. Flank wear always takes place and cannot be avoided. It should not give rise to concern unless the rate of flank wear is too fast or the flank wear land becomes too large in size. The size of the flank wear can be measured as the distance between the top of the cutting edge and the bottom of the flank wear land. In practice, a visual estimate is usually made instead of a precise measurement, although in many instances flank wear is ignored and the tool wear is "measured" by the loss of size on the part. The best measure of tool wear, however, is flank wear. When it becomes too large, the rubbing action of the wear land against the workpiece increases and the cutting edge must be replaced. Because conditions vary, it is not possible to give an exact amount of flank wear at which the tool should be replaced. Although there are many exceptions, as a rough estimate, high-speed steel tools should be replaced when the width of the flank wear land reaches 0.005 to 0.010 inch



for finish turning and 0.030 to 0.060 inch for rough turning; and for cemented carbides 0.005 to 0.010 inch for finish turning and 0.020 to 0.040 inch for rough turning.

Under ideal conditions which, surprisingly, occur quite frequently, the width of the flank wear land will be very uniform along its entire length. When the depth of cut is uneven, such as when turning out-of-round stock, the bottom edge of the wear land may become somewhat slanted, the wear land being wider toward the nose. A jagged-appearing wear land usually is evidence of chipping at the cutting edge. Sometimes, only one or two sharp depressions of the lower edge of the wear land will appear, to indicate that the cutting edge has chipped above these depressions. A deep notch will sometimes occur at the "depth of cut line," or that part of the cutting opposite the original surface of the work. This can be caused by a hard surface scale on the work, by a work-hardened surface layer on the work, or when machining high-temperature alloys. Often the size of the wear land is enlarged at the nose of the tool. This can be a sign of crater breakthrough near the nose or of chipping in this region. Under certain conditions, when machining with carbides, it can be an indication of deformation of the cutting edge in the region of the nose.

When a sharp tool is first used, the initial amount of flank wear is quite large in relation to the subsequent total amount. Under normal operating conditions, the width of the flank wear land will increase at a uniform rate until it reaches a critical size after which the cutting edge breaks down completely. This is called catastrophic failure and the cutting edge should be replaced before this occurs. When cutting at slow speeds with high-speed steel tools, there may be long periods when no increase in the flank wear can be observed. For a given work material and tool material, the rate of flank wear is primarily dependent on the cutting speed and then the feed rate.

*Cratering:* A deep crater will sometimes form on the face of the tool which is easily recognizable. The crater forms at a short distance behind the side cutting edge leaving a small shelf between the cutting edge and the edge of the crater. This shelf is sometimes covered with the built-up edge and at other times it is uncovered. Often the bottom of the crater is obscured with work material that is welded to the tool in this region. Under normal operating conditions, the crater will gradually enlarge until it breaks through a part of the cutting edge. Usually this occurs on the end cutting edge just behind the nose. When this takes place, the flank wear at the nose increases rapidly and complete tool failure follows shortly. Sometimes cratering cannot be avoided and a slow increase in the size of the crater is considered normal. However, if the rate of crater growth is rapid, leading to a short tool life, corrective measures must be taken.

*Cutting Edge Chipping:* Small chips are sometimes broken from the cutting edge which accelerates tool wear but does not necessarily cause immediate tool failure. Chipping can be recognized by the appearance of the cutting edge and the flank wear land. A sharp depression in the lower edge of the wear land is a sign of chipping and if this edge of the wear land has a jagged appearance it indicates that a large amount of chipping has taken place. Often the vacancy or cleft in the cutting edge that results from chipping is filled up with work material that is tightly welded in place. This occurs very rapidly when chipping is caused by a built-up edge on the face of the tool. In this manner the damage to the cutting edge is healed; however, the width of the wear land below the chip is usually increased and the tool life is shortened.

*Deformation:* Deformation occurs on carbide cutting tools when taking a very heavy cut using a slow cutting speed and a high feed rate. A large section of the cutting edge then becomes very hot and the heavy cutting pressure compresses the nose of the cutting edge, thereby lowering the face of the tool in the area of the nose. This reduces the relief under the nose, increases the width of the wear land in this region, and shortens the tool life.

*Surface Finish:* The finish on the machined surface does not necessarily indicate poor cutting tool performance unless there is a rapid deterioration. A good surface finish is, however, sometimes a requirement. The principal cause of a poor surface finish is the

built-up edge which forms along the edge of the cutting tool. The elimination of the built-up edge will always result in an improvement of the surface finish. The most effective way to eliminate the built-up edge is to increase the cutting speed. When the cutting speed is increased beyond a certain critical cutting speed, there will be a rather sudden and large improvement in the surface finish. Cemented carbide tools can operate successfully at higher cutting speeds, where the built-up edge does not occur and where a good surface finish is obtained. Whenever possible, cemented carbide tools should be operated at cutting speeds where a good surface finish will result. There are times when such speeds are not possible. Also, high-speed tools cannot be operated at the speed where the built-up edge does not form. In these conditions the most effective method of obtaining a good surface finish is to employ a cutting fluid that has active sulphur or chlorine additives.

Cutting tool materials that do not alloy readily with the work material are also effective in obtaining an improved surface finish. Straight titanium carbide and diamond are the two principal tool materials that fall into this category.

The presence of feed marks can mar an otherwise good surface finish and attention must be paid to the feed rate and the nose radius of the tool if a good surface finish is desired. Changes in the tool geometry can also be helpful. A small "flat," or secondary cutting edge, ground on the end cutting edge behind the nose will sometimes provide the desired surface finish. When the tool is in operation, the flank wear should not be allowed to become too large, particularly in the region of the nose where the finished surface is produced.

**Sharpening Twist Drills.**—Twist drills are cutting tools designed to perform concurrently several functions, such as penetrating directly into solid material, ejecting the removed chips outside the cutting area, maintaining the essentially straight direction of the advance movement and controlling the size of the drilled hole. The geometry needed for these multiple functions is incorporated into the design of the twist drill in such a manner that it can be retained even after repeated sharpening operations. Twist drills are resharpened many times during their service life, with the practically complete restitution of their original operational characteristics. However, in order to assure all the benefits which the design of the twist drill is capable of providing, the surfaces generated in the sharpening process must agree with the original form of the tool's operating surfaces, unless a change of shape is required for use on a different work material.

The principal elements of the tool geometry which are essential for the adequate cutting performance of twist drills are shown in Fig. 1. The generally used values for these dimensions are the following:

*Point angle:* Commonly 118°, except for high strength steels, 118° to 135°; aluminum alloys, 90° to 140°; and magnesium alloys, 70° to 118°.

*Helix angle:* Commonly 24° to 32°, except for magnesium and copper alloys, 10° to 30°.

*Lip relief angle:* Commonly 10° to 15°, except for high strength or tough steels, 7° to 12°.

The lower values of these angle ranges are used for drills of larger diameter, the higher values for the smaller diameters. For drills of diameters less than 1/4 inch, the lip relief angles are increased beyond the listed maximum values up to 24°. For soft and free machining materials, 12° to 18° except for diameters less than 1/4 inch, 20° to 26°.

**Relief Grinding of the Tool Flanks.**—In sharpening twist drills the tool flanks containing the two cutting edges are ground. Each flank consists of a curved surface which provides the relief needed for the easy penetration and free cutting of the tool edges. In grinding the flanks, Fig. 2, the drill is swung around the axis *A* of an imaginary cone while resting in a support which holds the drill at one-half the point angle *B* with respect to the face of the grinding wheel. Feed for stock removal is in the direction of the drill axis. The relief angle is usually measured at the periphery of the twist drill and is also specified by that value. It is not a constant but should increase toward the center of the drill.

The relief grinding of the flank surfaces will generate the chisel angle on the web of the twist drill. The value of that angle, typically  $55^\circ$ , which can be measured, for example, with the protractor of an optical projector, is indicative of the correctness of the relief grinding.

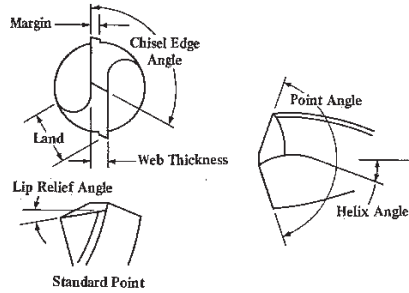

Fig. 1. The principal elements of tool geometry on twist drills.

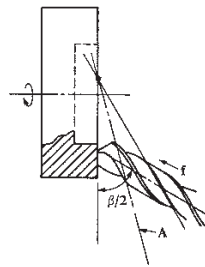

Fig. 2. In grinding the face of the twist drill the tool is swung around the axis  $A$  of an imaginary cone, while resting in a support tilted by half of the point angle  $\beta$  with respect to the face of the grinding wheel. Feed  $f$  for stock removal is in the direction of the drill axis.

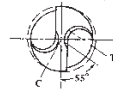

Fig. 3. The chisel edge  $C$  after thinning the web by grinding off area  $T$ .

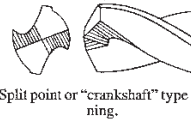

Fig. 4. Split point or "crankshaft" type web thinning.

**Drill Point Thinning.**—The chisel edge is the least efficient operating surface element of the twist drill because it does not cut, but actually squeezes or extrudes the work material. To improve the inefficient cutting conditions caused by the chisel edge, the point width is often reduced in a drill-point thinning operation, resulting in a condition such as that shown in Fig. 3. Point thinning is particularly desirable on larger size drills and also on those which become shorter in usage, because the thickness of the web increases toward the shaft of the twist drill, thereby adding to the length of the chisel edge. The extent of point thinning is limited by the minimum strength of the web needed to avoid splitting of the drill point under the influence of cutting forces.

Both sharpening operations—the relieved face grinding and the point thinning—should be carried out in special drill grinding machines or with twist drill grinding fixtures mounted on general-purpose tool grinding machines, designed to assure the essential accu-

racy of the required tool geometry. Off-hand grinding may be used for the important web thinning when a special machine is not available; however, such operation requires skill and experience.

Improperly sharpened twist drills, e.g. those with unequal edge length or asymmetrical point angle, will tend to produce holes with poor diameter and directional control.

For deep holes and also drilling into stainless steel, titanium alloys, high temperature alloys, nickel alloys, very high strength materials and in some cases tool steels, split point grinding, resulting in a "crankshaft" type drill point, is recommended. In this type of pointing, see Fig. 4, the chisel edge is entirely eliminated, extending the positive rake cutting edges to the center of the drill, thereby greatly reducing the required thrust in drilling. Points on modified-point drills must be restored after sharpening to maintain their increased drilling efficiency.

**Sharpening Carbide Tools.**—Cemented carbide indexable inserts are usually not resharpened but sometimes they require a special grind in order to form a contour on the cutting edge to suit a special purpose. Brazed type carbide cutting tools are resharpened after the cutting edge has become worn. On brazed carbide tools the cutting-edge wear should not be allowed to become excessive before the tool is re-sharpened. One method of determining when brazed carbide tools need resharpening is by periodic inspection of the flank wear and the condition of the face. Another method is to determine the amount of production which is normally obtained before excessive wear has taken place, or to determine the equivalent period of time. One disadvantage of this method is that slight variations in the work material will often cause the wear rate not to be uniform and the number of parts machined before regrinding will not be the same each time. Usually, sharpening should not require the removal of more than 0.005 to 0.010 inch of carbide.

*General Procedure in Carbide Tool Grinding:* The general procedure depends upon the kind of grinding operation required. If the operation is to resharpen a dull tool, a diamond wheel of 100 to 120 grain size is recommended although a finer wheel—up to 150 grain size—is sometimes used to obtain a better finish. If the tool is new or is a "standard" design and changes in shape are necessary, a 100-grit diamond wheel is recommended for roughing and a finer grit diamond wheel can be used for finishing. Some shops prefer to rough grind the carbide with a vitrified silicon carbide wheel, the finish grinding being done with a diamond wheel. A final operation commonly designated as lapping may or may not be employed for obtaining an extra-fine finish.

*Wheel Speeds:* The speed of silicon carbide wheels usually is about 5000 feet per minute. The speeds of diamond wheels generally range from 5000 to 6000 feet per minute; yet lower speeds (550 to 3000 fpm) can be effective.

*Offhand Grinding:* In grinding single-point tools (excepting chip breakers) the common practice is to hold the tool by hand, press it against the wheel face and traverse it continuously across the wheel face while the tool is supported on the machine rest or table which is adjusted to the required angle. This is known as "offhand grinding" to distinguish it from the machine grinding of cutters as in regular cutter grinding practice. The selection of wheels adapted to carbide tool grinding is very important.

**Silicon Carbide Wheels.**—The green colored silicon carbide wheels generally are preferred to the dark gray or gray-black variety, although the latter are sometimes used.

*Grain or Grit Sizes:* For roughing, a grain size of 60 is very generally used. For finish grinding with silicon carbide wheels, a finer grain size of 100 or 120 is common. A silicon carbide wheel such as C60-I-7V may be used for grinding both the steel shank and carbide tip. However, for under-cutting steel shanks up to the carbide tip, it may be advantageous to use an aluminum oxide wheel suitable for grinding softer, carbon steel.

*Grade:* According to the standard system of marking, different grades from soft to hard are indicated by letters from A to Z. For carbide tool grinding fairly soft grades such as G, H, I, and J are used. The usual grades for roughing are I or J and for finishing H, I, and J. The

grade should be such that a sharp free-cutting wheel will be maintained without excessive grinding pressure. Harder grades than those indicated tend to overheat and crack the carbide.

*Structure:* The common structure numbers for carbide tool grinding are 7 and 8. The larger cup-wheels (10 to 14 inches) may be of the porous type and be designated as 12P. The standard structure numbers range from 1 to 15 with progressively higher numbers indicating less density and more open wheel structure.

**Diamond Wheels.**—Wheels with diamond-impregnated grinding faces are fast and cool cutting and have a very low rate of wear. They are used extensively both for resharpening and for finish grinding of carbide tools when preliminary roughing is required. Diamond wheels are also adapted for sharpening multi-tooth cutters such as milling cutters, reamers, etc., which are ground in a cutter grinding machine.

*Resinoid bonded* wheels are commonly used for grinding chip breakers, milling cutters, reamers or other multi-tooth cutters. They are also applicable to precision grinding of carbide dies, gages, and various external, internal and surface grinding operations. Fast, cool cutting action is characteristic of these wheels.

*Metal bonded* wheels are often used for offhand grinding of single-point tools especially when durability or long life and resistance to grooving of the cutting face, are considered more important than the rate of cutting. *Vitrified bonded* wheels are used both for roughing of chipped or very dull tools and for ordinary resharpening and finishing. They provide rigidity for precision grinding, a porous structure for fast cool cutting, sharp cutting action and durability.

**Diamond Wheel Grit Sizes.**—For roughing with diamond wheels a grit size of 100 is the most common both for offhand and machine grinding.

Grit sizes of 120 and 150 are frequently used in offhand grinding of single point tools 1) for resharpening; 2) for a combination roughing and finishing wheel; and 3) for chip-breaker grinding.

Grit sizes of 220 or 240 are used for ordinary finish grinding all types of tools (offhand and machine) and also for cylindrical, internal and surface finish grinding. Grits of 320 and 400 are used for "lapping" to obtain very fine finishes, and for hand hones. A grit of 500 is for lapping to a mirror finish on such work as carbide gages and boring or other tools for exceptionally fine finishes.

**Diamond Wheel Grades.**—Diamond wheels are made in several different grades to better adapt them to different classes of work. The grades vary for different types and shapes of wheels. Standard Norton grades are H, J, and L, for resinoid bonded wheels, grade N for metal bonded wheels and grades J, L, N, and P, for vitrified wheels. Harder and softer grades than standard may at times be used to advantage.

**Diamond Concentration.**—The relative amount (by carat weight) of diamond in the diamond section of the wheel is known as the "diamond concentration." Concentrations of 100 (high), 50 (medium) and 25 (low) ordinarily are supplied. A concentration of 50 represents one-half the diamond content of 100 (if the depth of the diamond is the same in each case) and 25 equals one-fourth the content of 100 or one-half the content of 50 concentration.

*100 Concentration:* Generally interpreted to mean 72 carats of diamond/in.<sup>3</sup> of abrasive section. (A 75 concentration indicates 54 carats/in.<sup>3</sup>.) Recommended (especially in grit sizes up to about 220) for general machine grinding of carbides, and for grinding cutters and chip breakers. Vitrified and metal bonded wheels usually have 100 concentration.

*50 Concentration:* In the finer grit sizes of 220, 240, 320, 400, and 500, a 50 concentration is recommended for offhand grinding with resinoid bonded cup-wheels.

**25 Concentration:** A low concentration of 25 is recommended for offhand grinding with resinoid bonded cup-wheels with grit sizes of 100, 120 and 150.

**Depth of Diamond Section:** The radial depth of the diamond section usually varies from  $\frac{1}{16}$  to  $\frac{1}{4}$  inch. The depth varies somewhat according to the wheel size and type of bond.

**Dry Versus Wet Grinding of Carbide Tools.**—In using silicon carbide wheels, grinding should be done either absolutely dry or with enough coolant to flood the wheel and tool. Satisfactory results may be obtained either by the wet or dry method. However, dry grinding is the most prevalent usually because, in wet grinding, operators tend to use an inadequate supply of coolant to obtain better visibility of the grinding operation and avoid getting wet; hence checking or cracking in many cases is more likely to occur in wet grinding than in dry grinding.

**Wet Grinding with Silicon Carbide Wheels:** One advantage commonly cited in connection with wet grinding is that an ample supply of coolant permits using wheels about one grade harder than in dry grinding thus increasing the wheel life. Plenty of coolant also prevents thermal stresses and the resulting cracks, and there is less tendency for the wheel to load. A dust exhaust system also is unnecessary.

**Wet Grinding with Diamond Wheels:** In grinding with diamond wheels the general practice is to use a coolant to keep the wheel face clean and promote free cutting. The amount of coolant may vary from a small stream to a coating applied to the wheel face by a felt pad.

**Coolants for Carbide Tool Grinding.**—In grinding either with silicon carbide or diamond wheels a coolant that is used extensively consists of water plus a small amount either of soluble oil, sal soda, or soda ash to prevent corrosion. One prominent manufacturer recommends for silicon carbide wheels about 1 ounce of soda ash per gallon of water and for diamond wheels kerosene. The use of kerosene is quite general for diamond wheels and usually it is applied to the wheel face by a felt pad. Another coolant recommended for diamond wheels consists of 80 per cent water and 20 per cent soluble oil.

**Peripheral Versus Flat Side Grinding.**—In grinding single point carbide tools with silicon carbide wheels, the roughing preparatory to finishing with diamond wheels may be done either by using the flat face of a cup-shaped wheel (side grinding) or the periphery of a "straight" or disk-shaped wheel. Even where side grinding is preferred, the periphery of a straight wheel may be used for heavy roughing as in grinding back chipped or broken tools (see left-hand diagram). Reasons for preferring peripheral grinding include faster cutting with less danger of localized heating and checking especially in grinding broad surfaces. The advantages usually claimed for side grinding are that proper rake or relief angles are easier to obtain and the relief or land is ground flat. The diamond wheels used for tool sharpening are designed for side grinding. (See right-hand diagram.)

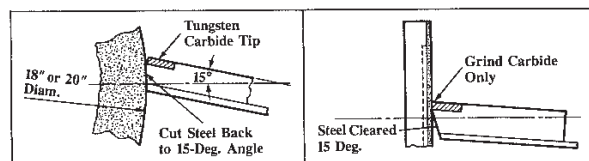

**Lapping Carbide Tools.**—Carbide tools may be finished by lapping, especially if an exceptionally fine finish is required on the work as, for example, tools used for precision boring or turning non-ferrous metals. If the finishing is done by using a diamond wheel of very fine grit (such as 240, 320, or 400), the operation is often called "lapping." A second lapping method is by means of a power-driven lapping disk charged with diamond dust, Norbide powder, or silicon carbide finishing compound. A third method is by using a hand lap or hone usually of 320 or 400 grit. In many plants the finishes obtained with carbide tools meet requirements without a special lapping operation. In all cases any feather edge which may be left on tools should be removed and it is good practice to bevel the edges of roughing tools at 45 degrees to leave a chamfer 0.005 to 0.010 inch wide. This is done by hand honing and the object is to prevent crumbling or flaking off at the edges when hard scale or heavy chip pressure is encountered.

*Hand Honing:* The cutting edge of carbide tools, and tools made from other tool materials, is sometimes hand honed before it is used in order to strengthen the cutting edge. When interrupted cuts or heavy roughing cuts are to be taken, or when the grade of carbide is slightly too hard, hand honing is beneficial because it will prevent chipping, or even possibly, breakage of the cutting edge. Whenever chipping is encountered, hand honing the cutting edge before use will be helpful. It is important, however, to hone the edge lightly and only when necessary. Heavy honing will always cause a reduction in tool life. Normally, removing 0.002 to 0.004 inch from the cutting edge is sufficient. When indexable inserts are used, the use of pre-honed inserts is preferred to hand honing although sometimes an additional amount of honing is required. Hand honing of carbide tools in between cuts is sometimes done to defer grinding or to increase the life of a cutting edge on an indexable insert. If correctly done, so as not to change the relief angle, this procedure is sometimes helpful. If improperly done, it can result in a reduction in tool life.

**Chip Breaker Grinding.**—For this operation a straight diamond wheel is used on a universal tool and cutter grinder, a small surface grinder, or a special chipbreaker grinder. A resinoid bonded wheel of the grade J or N commonly is used and the tool is held rigidly in an adjustable holder or vise. The width of the diamond wheel usually varies from  $\frac{1}{8}$  to  $\frac{1}{4}$  inch. A vitrified bond may be used for wheels as thick as  $\frac{1}{4}$  inch, and a resinoid bond for relatively narrow wheels.

**Summary of Miscellaneous Points.**—In grinding a single-point carbide tool, traverse it across the wheel face continuously to avoid localized heating. This traverse movement should be quite rapid in using silicon carbide wheels and comparatively slow with diamond wheels. A hand traversing and feeding movement, whenever practicable, is generally recommended because of greater sensitivity. In grinding, maintain a constant, moderate pressure. Manipulating the tool so as to keep the contact area with the wheel as small as possible will reduce heating and increase the rate of stock removal. Never cool a hot tool by dipping it in a liquid, as this may crack the tip. Wheel rotation should preferably be *against* the cutting edge or from the front face toward the back. If the grinder is driven by a reversing motor, opposite sides of a cup wheel can be used for grinding right- and left-hand tools and with rotation against the cutting edge. If it is necessary to grind the top face of a single-point tool, this should precede the grinding of the side and front relief, and top-face grinding should be minimized to maintain the tip thickness. In machine grinding with a diamond wheel, limit the feed per traverse to 0.001 inch for 100 to 120 grit; 0.0005 inch for 150 to 240 grit; and 0.0002 inch for 320 grit and finer.

JIGS AND FIXTURES

**Material for Jig Bushings.**—Bushings are generally made of a good grade of tool steel to ensure hardening at a fairly low temperature and to lessen the danger of fire cracking. They can also be made from machine steel, which will answer all practical purposes, provided the bushings are properly casehardened to a depth of about  $\frac{1}{16}$  inch. Sometimes, bushings for guiding tools may be made of cast iron, but only when the cutting tool is of such a design that no cutting edges come within the bushing itself. For example, bushings used simply to support the smooth surface of a boring-bar or the shank of a reamer might, in some instances, be made of cast iron, but hardened steel bushings should always be used for guiding drills, reamers, taps, etc., when the cutting edges come in direct contact with the guiding surfaces. If the outside diameter of the bushing is very large, as compared with the diameter of the cutting tool, the cost of the bushing can sometimes be reduced by using an outer cast-iron body and inserting a hardened tool steel bushing.

When tool steel bushings are made and hardened, it is recommended that A-2 steel be used. The furnace should be set to 1750°F and the bushing placed in the furnace and held there approximately 20 minutes after the furnace reaches temperature. Remove the bushing and cool in still air. After the part cools to 100–150°F, immediately place in a tempering furnace that has been heated to 300°F. Remove the bushing after one hour and cool in still air. If an atmospherically controlled furnace is unavailable, the part should be wrapped in stainless foil to prevent scaling and oxidation at the 1750°F temperature.

**American National Standard Jig Bushings.**—Specifications for the following types of jig bushings are given in American National Standard B94.33-1974 (R1986). Head Type Press Fit Wearing Bushings, Type H (Fig. 1 and Tables 1 and 3); Headless Type Press Fit Wearing Bushings, Type P (Fig. 2 and Tables 1 and 3); Slip Type Renewable Wearing Bushings, Type S (Fig. 3 and Tables 4 and 5); Fixed Type Renewable Wearing Bushings, Type F (Fig. 4 and Tables 5 and 6); Headless Type Liner Bushings, Type L (Fig. 5 and Table 7); and Head Type Liner Bushings, Type HL (Fig. 6 and Table 8). Specifications for locking mechanisms are also given in Table 9.

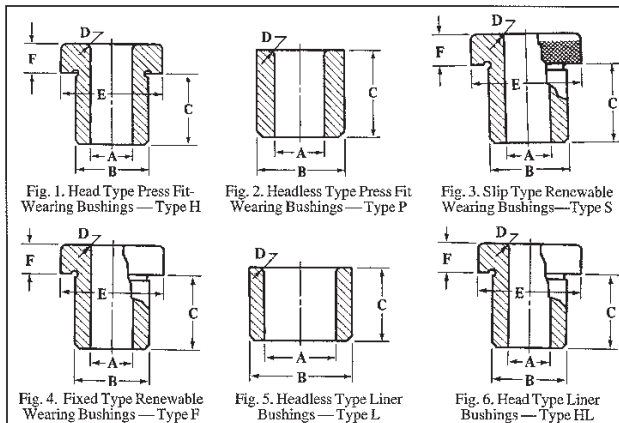



**Table 1. American National Standard Head Type Press Fit Wearing Bushings—Type H ANSIB94.33-1974, R1986**

Range of Hole Sizes A	Body Diameter B					Body Length C	Radius D	Head Diam. E Max	Head Thickness F Max	Number
	Unfinished		Finished							
	Nom	Max	Min	Max	Min					
0.0135 up to and including 0.0625	0.156	0.166	0.161	0.1578	0.1575	0.250	0.016	0.250	0.094	H-10-4
						0.312				H-10-5
						0.375				H-10-6
						0.500				H-10-8
0.0630 to 0.0995	0.203	0.213	0.208	0.2046	0.2043	0.250	0.016	0.312	0.094	H-13-4
						0.312				H-13-5
						0.375				H-13-6
						0.500				H-13-8
						0.750				H-13-12
0.1015 to 0.1405	0.250	0.260	0.255	0.2516	0.2513	0.250	0.016	0.375	0.094	H-16-4
						0.312				H-16-5
						0.375				H-16-6
						0.500				H-16-8
0.1406 to 0.1875	0.312	0.327	0.322	0.3141	0.3138	0.250	0.031	0.438	0.125	H-20-4
						0.312				H-20-5
						0.375				H-20-6
						0.500				H-20-8
						0.750				H-20-12
0.189 to 0.2500	0.406	0.421	0.416	0.4078	0.4075	0.250	0.031	0.531	0.156	H-26-4
						0.312				H-26-5
						0.375				H-26-6
						0.500				H-26-8
						0.750				H-26-12
						1.000				H-26-15
0.2570 to 0.3125	0.500	0.520	0.515	0.5017	0.5014	0.312	0.047	0.625	0.219	H-32-5
						0.375				H-32-6
						0.500				H-32-8
						0.750				H-32-12
						1.000				H-32-16
						1.375				H-32-22
0.3160 to 0.4219	0.625	0.645	0.640	0.6267	0.6264	0.312	0.047	0.812	0.219	H-40-5
						0.375				H-40-6
						0.500				H-40-8
						0.750				H-40-12
						1.000				H-40-16
						1.375				H-40-22
0.4375 to 0.5000	0.750	0.770	0.765	0.7518	0.7515	0.500	0.062	0.938	0.219	H-48-8
						0.750				H-48-12
						1.000				H-48-16
						1.375				H-48-22
						1.750				H-48-28
						2.125				H-48-34
0.5156 to 0.6250	0.875	0.895	0.890	0.8768	0.8765	0.500	0.062	0.125	0.250	H-56-8
						0.750				H-56-12
						1.000				H-56-16
						1.375				H-56-22
						1.750				H-56-28
						2.125				H-56-34
2.500	H-56-40									

**Table 1. (Continued) American National Standard Head Type Press Fit Wearing Bushings — Type H ANSI B94.33-1974, R1986**

Range of Hole Sizes A	Body Diameter B					Body Length C	Radius D	Head Diam. E Max	Head Thickness F Max	Number
	Unfinished			Finished						
	Nom	Max	Min	Max	Min					
0.6406 to 0.7500	1.000	1.020	1.015	1.0018	1.0015	0.500	0.094	1.250	0.312	H-64-8
						0.750				H-64-12
						1.000				H-64-16
						1.375				H-64-22
						1.750				H-64-28
						2.125				H-64-34
2.500	H-64-40									
0.7656 to 1.0000	1.375	1.395	1.390	1.3772	1.3768	0.750	0.094	1.625	0.375	H-88-12
						1.000				H-88-16
						1.375				H-88-22
						1.750				H-88-28
						2.125				H-88-34
						2.500				H-88-40
1.0156 to 1.3750	1.750	1.770	1.765	1.7523	1.7519	1.000	0.094	2.000	0.375	H-112-16
						1.375				H-112-22
						1.750				H-112-28
						2.125				H-112-34
						2.500				H-112-40
						3.000				H-112-48
1.3906 to 1.7500	2.250	2.270	2.265	2.2525	2.2521	1.000	0.094	2.500	0.375	H-144-16
						1.375				H-144-22
						1.750				H-144-28
						2.125				H-144-34
						2.500				H-144-40
						3.000				H-144-48

All dimensions are in inches.  
See also Table 3 for additional specifications.

**Table 2. American National Standard Headless Type Press Fit Wearing Bushings — Type P ANSI B94.33-1974, R1986**

Range of Hole Sizes A	Body Diameter B					Body Length C	Radius D	Number
	Unfinished			Finished				
	Nom	Max	Min	Max	Min			
0.0135 up to and including 0.0625	0.156	0.166	0.161	0.1578	0.1575	0.250	0.016	P-10-4
						0.312		P-10-5
						0.375		P-10-6
						0.500		P-10-8
0.0630 to 0.0995	0.203	0.213	0.208	0.2046	0.2043	0.250	0.016	P-13-4
						0.312		P-13-5
						0.375		P-13-6
						0.500		P-13-8
						0.750		P-13-12
0.1015 to 0.1405	0.250	0.260	0.255	0.2516	0.2513	0.250	0.016	P-16-4
						0.312		P-16-5
						0.375		P-16-6
						0.500		P-16-8
0.1406 to 0.1875	0.312	0.327	0.322	0.3141	0.3138	0.750	0.031	P-16-12
						0.250		P-20-4
						0.312		P-20-5
						0.375		P-20-6
						0.500		P-20-8
0.750	P-20-12							
1.000	P-20-16							

**Table 2. American National Standard Headless Type Press Fit Wearing Bushings — Type P ANSIB94.33-1974, R1986**

Range of Hole Sizes A	Body Diameter B					Body Length C	Radius D	Number
	Unfinished		Finished					
	Nom	Max	Min	Max	Min			
0.1890 to 0.2500	0.406	0.421	0.416	0.4078	0.4075	0.250	0.031	P-26-4
						0.312		P-26-5
						0.375		P-26-6
						0.500		P-26-8
						0.750		P-26-12
						1.000		P-26-16
						1.750		P-26-22
0.2570 to 0.3125	0.500	0.520	0.515	0.5017	0.5014	0.312	0.047	P-32-5
						0.375		P-32-6
						0.500		P-32-8
						0.750		P-32-12
						1.000		P-32-16
						1.375		P-32-22
						1.750		P-32-28
0.3160 to 0.4219	0.625	0.645	0.640	0.6267	0.6264	0.312	0.047	P-40-5
						0.375		P-40-6
						0.500		P-40-8
						0.750		P-40-12
						1.000		P-40-16
						1.375		P-40-22
						1.750		P-40-28
0.4375 to 0.5000	0.750	0.770	0.765	0.7518	0.7515	0.500	0.062	P-48-8
						0.750		P-48-12
						1.000		P-48-16
						1.375		P-48-22
						1.750		P-48-28
						2.125		P-48-34
						2.500		P-48-40
0.5156 to 0.6250	0.875	0.895	0.890	0.8768	0.8765	0.500	0.062	P-56-8
						0.750		P-56-12
						1.000		P-56-16
						1.375		P-56-22
						1.750		P-56-28
						2.125		P-56-34
						2.500		P-56-40
0.6406 to 0.7500	1.000	1.020	1.015	1.0018	1.0015	0.500	0.062	P-64-8
						0.750		P-64-12
						1.000		P-64-16
						1.375		P-64-22
						1.750		P-64-28
						2.125		P-64-34
						2.500		P-64-40
0.7656 to 1.0000	1.375	1.395	1.390	1.3772	1.3768	0.750	0.094	P-88-12
						1.000		P-88-16
						1.375		P-88-22
						1.750		P-88-28
						2.125		P-88-34
						2.500		P-88-40
						1.0156 to 1.3750		1.750
1.375	P-112-22							
1.750	P-112-28							
2.125	P-112-34							
2.500	P-112-40							
3.000	P-112-48							
1.3906 to 1.7500	2.250	2.270	2.265	2.2525	2.2521		1.000	
						1.375	P-144-22	
						1.750	P-144-28	
						2.125	P-144-34	
						2.500	P-144-40	
						3.000	P-144-48	

All dimensions are in inches. See Table 3 for additional specifications.

**Table 3. Specifications for Head Type H and Headless Type P Press Fit Wearing Bushings ANSI B94.33-1974, R1986**

All dimensions given in inches. Tolerance on dimensions where not otherwise specified shall be  $\pm 0.010$  inch. Size and type of chamfer on lead end to be manufacturer's option. The length, C, is the overall length for the headless type and length underhead for the head type. The head design shall be in accordance with the manufacturer's practice. Diameter A must be concentric to diameter B within 0.0005 T.I.V. on finish ground bushings. The body diameter, B, for unfinished bushings is larger than the nominal diameter in order to provide grinding stock for fitting to jig plate holes. The grinding allowance is:

0.005 to 0.010 in. for sizes 0.156, 0.203 and 0.250 in.  
 0.010 to 0.015 in. for sizes 0.312 and 0.406 in.  
 0.015 to 0.020 in. for sizes 0.500 in. and up.

Hole sizes are in accordance with American National Standard Twist Drill Sizes. The maximum and minimum values of the hole size, A, shall be as follows:

Nominal Size of Hole	Maximum	Minimum
Above 0.0135 to 0.2500 in., incl.	Nominal + 0.0004 in.	Nominal + 0.0001 in.
Above 0.2500 to 0.7500 in., incl.	Nominal + 0.0005 in.	Nominal + 0.0001 in.
Above 0.7500 to 1.5000 in., incl.	Nominal + 0.0006 in.	Nominal + 0.0002 in.
Above 1.5000 in.	Nominal + 0.0007 in.	Nominal + 0.0003 in.

Bushings in the size range from 0.0135 through 0.3125 will be counterbored to provide for fabrication and chip clearance. Bushings without counterbore are optional and will be furnished upon request. The size of the counterbore shall be inside diameter of the bushing + 0.031 inch. The included angle at the bottom of the counterbore shall be 118 deg.  $\pm 2$  deg. The depth of the counterbore shall be in accordance with the table below to provide adequate drill bearing.

Body Length	Drill Bushing Hole Size												
	0.0135 to 0.0625		0.0630 to 0.0985		0.1015 to 0.1405		0.1406 to 0.1875		0.1890 to 0.2500		0.2570 to 0.3125		
	P	H	P	H	P	H	P	H	P	H	P	H	
0.250	X	0.250	X	X	X	X	X	X	X	X	X	X	X
0.312	X	0.250	X	X	X	X	X	X	X	X	X	X	X
0.375	0.250	0.250	X	X	X	X	X	X	X	X	X	X	X
0.500	0.250	0.250	X	0.312	X	0.312	X	0.375	X	X	X	X	X
0.750	+	+	0.375	0.375	0.375	0.375	X	0.375	X	X	X	X	X
1.000	+	+	+	+	+	0.625	0.625	0.625	0.625	0.625	0.625	0.625	0.625
1.375	+	+	+	+	+	+	+	0.625	0.625	0.625	0.625	0.625	0.625
1.750	+	+	+	+	+	+	+	0.625	0.625	0.625	0.625	0.625	0.625

All dimensions are in inches.

X indicates no counterbore.

+ indicates not American National Standard

**Table 4. American National Standard Slip Type Renewable Wearing Bushings—Type S ANSI B94.33-1974, R1986**

Range of Hole Sizes A	Body Diameter B			Length Under-Head C	Radius D	Head Diam. E Max	Head Thickness F Max	Number
	Nom	Max	Min					
0.0135 up to and including 0.0469	0.188	0.1875	0.1873	0.250	0.031	0.312	0.188	S-12-4
				0.312				S-12-5
				0.375				S-12-6
				0.500				S-12-8
0.0492 to 0.1562	0.312	0.3125	0.3123	0.312	0.047	0.562	0.375	S-20-3
				0.500				S-20-8
				0.750				S-20-12
				1.000				S-20-16
				1.600				S-20-16
0.1570 to 0.3125	0.500	0.5000	0.4998	0.312	0.047	0.812	0.438	S-32-5
				0.500				S-32-8
				0.750				S-32-12
				1.000				S-32-16
				1.375				S-32-22
				1.750				S-32-28
0.3160 to 0.5000	0.750	0.7500	0.7498	0.500	0.094	1.062	0.438	S-48-8
				0.750				S-48-12
				1.000				S-48-16
				1.375				S-48-22
				1.750				S-48-28
2.125	S-48-34							

**Table 4. (Continued) American National Standard Slip Type Renewable Wearing Bushings—Type S ANSI B94.33-1974, R1986**

Range of Hole Sizes A	Body Diameter B			Length Under-Head C	Radius D	Head Diam. E Max	Head Thickness F Max	Number
	Nom	Max	Min					
0.5156 to 0.7500	1.000	1.0000	0.9998	0.500	0.094	1.438	0.438	S-64-8
				0.750				S-64-12
				1.000				S-64-16
				1.375				S-64-22
				1.750				S-64-28
				2.125				S-64-34
0.7656 to 1.0000	1.375	1.3750	1.3747	0.750	0.094	1.812	0.438	S-88-12
				1.000				S-88-16
				1.375				S-88-22
				1.750				S-88-28
				2.125				S-88-34
				2.500				S-88-40
1.0156 to 1.3750	1.750	1.7500	1.7497	1.000	0.125	2.312	0.625	S-112-16
				1.375				S-112-22
				1.750				S-112-28
				2.125				S-112-34
				2.500				S-112-40
				3.000				S-112-48
1.3906 to 1.7500	2.250	2.2500	2.2496	1.000	0.125	2.812	0.625	S-144-16
				1.375				S-144-22
				1.750				S-144-28
				2.125				S-144-34
				2.500				S-144-40
				3.000				S-144-48

All dimensions are in inches. See also Table 5 for additional specifications.

**Table 5. Specifications for Slip Type S and Fixed Type F Renewable Wearing Bushings ANSI B94.33-1974, R1986**

Tolerance on dimensions where not otherwise specified shall be plus or minus 0.010 inch.  
 Hole sizes are in accordance with the American Standard Twist Drill Sizes.  
 The maximum and minimum values of hole size, A, shall be as follows:

Nominal Size of Hole	Maximum	Minimum
Above 0.0135 to 0.2500 in. incl.	Nominal + 0.0004 in.	Nominal + 0.0001 in.
Above 0.2500 to 0.7500 in. incl.	Nominal + 0.0005 in.	Nominal + 0.0001 in.
Above 0.7500 to 1.5000 in. incl.	Nominal + 0.0006 in.	Nominal + 0.0002 in.
Above 1.5000	Nominal + 0.0007 in.	Nominal + 0.0003 in.

The head design shall be in accordance with the manufacturer's practice.  
 Head of slip type is usually knurled.  
 When renewable wearing bushings are used with liner bushings of the head type, the length under the head will still be equal to the thickness of the jig plate, because the head of the liner bushing will be countersunk into the jig plate.  
 Diameter A must be concentric to diameter B within 0.0005 T.I.R. on finish ground bushings.  
 Size and type of chamfer on lead end to be manufacturer's option.  
 Bushings in the size range from 0.0135 through 0.3125 will be counterbored to provide for lubrication and chip clearance.  
 Bushings without counterbore are optional and will be furnished upon request.  
 The size of the counterbore shall be inside diameter of the bushings plus 0.031 inch.  
 The included angle at the bottom of the counterbore shall be 118 deg., plus or minus 2 deg.  
 The depth of the counterbore shall be in accordance with the table below to provide adequate drill bearing.

Body Length	Drill Bearing Hole Size												
	0.0135 to 0.0625		0.0620 to 0.0995		0.1015 to 0.1405		0.1405 to 0.1875		0.1890 to 0.2500		0.2500 to 0.3125		
	S	F	S	F	S	F	S	F	S	F	S	F	
	Minimum Drill Bearing Length												
0.250	0.250	0.250	0.375	0.375	X	X	X	X	X	X	X	X	X
0.312	0.250	0.250	0.375	0.375	0.375	0.375	0.375	0.375	0.375	0.375	0.375	X	X
0.375	0.250	0.250	0.375	0.375	0.375	0.375	0.375	0.375	0.375	0.375	0.375	X	X
0.500	0.250	0.250	0.375	0.375	0.375	0.375	0.375	0.375	0.375	0.375	0.375	X	X
0.750	0.250	0.250	0.375	0.375	0.375	0.375	0.375	0.375	0.625	0.625	0.625	0.625	0.625
1.000	0.312	0.312	0.375	0.375	0.375	0.375	0.625	0.625	0.625	0.625	0.625	0.625	0.625
1.375	+	+	+	+	+	-	0.625	0.625	0.625	0.625	0.625	0.625	0.625
1.750	+	+	+	+	+	+	0.625	0.625	0.625	0.625	0.625	0.625	0.625

All dimensions are in inches.  
 X indicates no counterbore.  
 + indicates not American National Standard length.

**Table 6. American National Standard Fixed Type Renewable Wearing Bushings — Type F** *ANSI B94.33-1974, R1986*

Range of Hole Sizes A	Body Diameter B			Length Under Head C	Radius D	Head Diam. E Max	Head Thickness F Max	Number
	Nom	Max	Min					
0.0135 up to and including 0.0469	0.168	0.1875	0.1873	0.250	0.031	0.312	0.188	F-12-4
				0.312				F-12-5
				0.375				F-12-6
				0.500				F-12-8
0.0492 to 0.1562	0.312	0.3125	0.3123	0.312	0.047	0.562	0.250	F-20-5
				0.500				F-20-8
				0.750				F-20-12
				1.000				F-20-16
0.1570 to 0.3125	0.500	0.5000	0.4998	0.312	0.047	0.812	0.250	F-32-5
				0.500				F-32-8
				0.750				F-32-12
				1.000				F-32-16
				1.375				F-32-22
0.3160 to 0.5000	0.750	0.7500	0.7498	1.750	0.094	1.062	0.250	F-32-28
				0.500				F-48-8
				0.750				F-48-12
				1.000				F-48-16
				1.375				F-48-22
0.5156 to 0.7500	1.000	1.0000	0.9998	1.750	0.094	1.438	0.375	F-48-28
				2.125				F-48-34
				2.500				F-64-8
				0.500				F-64-12
				0.750				F-64-16
0.7656 to 1.0000	1.375	1.3750	1.3747	1.000	0.094	1.812	0.375	F-64-22
				1.375				F-64-28
				1.750				F-64-34
				2.125				F-64-40
				2.500				F-88-12
1.0156 to 1.3750	1.750	1.7500	1.7497	1.000	0.125	2.312	0.375	F-88-16
				1.375				F-88-22
				1.750				F-88-28
				2.125				F-88-34
				2.500				F-88-40
1.3906 to 1.7500	2.250	2.2500	2.2496	3.000	0.125	2.812	0.375	F-112-16
				1.000				F-112-22
				1.375				F-112-28
				1.750				F-112-34
				2.125				F-112-40
1.3906 to 1.7500	2.250	2.2500	2.2496	3.000	0.125	2.812	0.375	F-112-48
				1.000				F-144-16
				1.375				F-144-22
				1.750				F-144-28
				2.125				F-144-34
1.3906 to 1.7500	2.250	2.2500	2.2496	2.500	0.125	2.812	0.375	F-144-40
				3.000				F-144-48
				3.000				F-144-48

All dimensions are in inches. See also Table 5 for additional specifications.

**Table 7. American National Standard Headless Type Liner Bushings — Type L ANSI**  
*B94.33-1974, R1986*

Range of Hole Sizes in Renewable Bushings	Inside Diameter A			Body Diameter B					Over-all Length C	Radius D	Number
				Unfinished		Finished					
	Nom	Max	Min	Nom	Max	Min	Max	Min			
0.0135 up to and including 0.0469	0.188	0.1879	0.1876	0.312	0.3341	0.3288	0.3141	0.3138	0.250	0.031	L-20-4
									0.312		L-20-5
									0.375		L-20-6
0.0492 to 0.1562	0.312	0.3129	0.3126	0.500	0.520	0.515	0.5017	0.5014	0.500	0.047	L-32-5
									0.750		L-32-8
									1.000		L-32-12
0.1570 to 0.3125	0.500	0.5005	0.5002	0.750	0.770	0.765	0.7518	0.7515	0.312	0.062	L-48-5
									0.500		L-48-8
									0.750		L-48-12
0.3160 to 0.5000	0.750	0.7506	0.7503	1.000	1.020	1.015	1.0018	1.0015	1.000	0.062	L-64-8
									1.375		L-64-12
									1.750		L-64-16
0.5156 to 0.7500	1.000	1.0007	1.0004	1.375	1.395	1.390	1.3772	1.3768	1.375	0.094	L-64-22
									1.750		L-64-28
									2.125		L-64-34
0.7656 to 1.0000	1.375	1.3769	1.3756	1.750	1.770	1.765	1.7523	1.7519	0.500	0.094	L-88-8
									1.750		L-88-12
									2.125		L-88-16
1.0156 to 1.3750	1.750	1.7512	1.7508	2.250	2.270	2.265	2.2525	2.2521	1.000	0.094	L-88-22
									1.375		L-88-28
									2.500		L-88-34
1.3906 to 1.7500	2.250	2.2515	2.2510	2.750	2.770	2.765	2.7526	2.7522	2.500	0.125	L-112-12
									3.000		L-112-16
											L-112-22
1.3906 to 1.7500	2.250	2.2515	2.2510	2.750	2.770	2.765	2.7526	2.7522	1.750	0.125	L-112-28
									2.125		L-112-34
									3.000		L-112-49
1.3906 to 1.7500	2.250	2.2515	2.2510	2.750	2.770	2.765	2.7526	2.7522	1.000	0.125	L-144-16
									1.375		L-144-22
									1.750		L-144-28
1.3906 to 1.7500	2.250	2.2515	2.2510	2.750	2.770	2.765	2.7526	2.7522	2.125	0.125	L-144-34
									2.500		L-144-40
									3.000		L-144-48
1.3906 to 1.7500	2.250	2.2515	2.2510	2.750	2.770	2.765	2.7526	2.7522	1.000	0.125	L-176-16
									1.375		L-176-22
									1.750		L-176-28
1.3906 to 1.7500	2.250	2.2515	2.2510	2.750	2.770	2.765	2.7526	2.7522	2.125	0.125	L-176-34
									2.500		L-176-40
									3.000		L-176-48

All dimensions are in inches.

Tolerances on dimensions where otherwise not specified are  $\pm 0.010$  in.

The body diameter, B, for unfinished bushings is 0.015 to 0.020 in. larger than the nominal diameter in order to provide grinding stock for fitting to jig plate holes.

Diameter A must be concentric to diameter B within 0.0005 T.I.R. on finish ground bushings.

**Table 8. American National Standard Head Type Liner Bushing — Type HL**  
ANSI B94.33-1974, R1986

Range of Hole Sizes in Renewable Bushings	Inside Diameter A			Body Diameter B					Overall Length C	Radius D	Head Dia. E	Head Thickness F Max	Number
				Unfinished			Finished						
	Nom	Max	Min	Nom	Max	Min	Max	Min					
0.0135 to 0.1562	0.312	0.3129	0.3126	0.500	0.520	0.515	0.5017	0.5014	0.312	0.047	0.625	0.094	HL-32-5
				0.500					0.500				HL-32-8
				0.750					0.750				HL-32-12
				1.000					1.000				HL-32-16
0.1570 to 0.3125	0.500	0.5005	0.5002	0.750	0.770	0.765	0.7518	0.7515	0.312	0.062	0.875	0.094	HL-48-5
				0.750					0.500				HL-48-8
				1.000					0.750				HL-48-12
				1.375					1.000				HL-48-16
0.3160 to 0.5000	0.750	0.7506	0.7503	1.000	1.020	1.015	1.0018	1.0015	1.375	0.062	1.125	0.125	HL-48-22
				1.000					1.750				HL-48-28
				1.375					1.375				HL-64-8
				2.125					2.125				HL-64-12
0.5156 to 0.7500	1.000	1.0007	1.0004	1.375	1.395	1.390	1.3772	1.3768	1.000	0.094	1.500	0.125	HL-64-16
				1.375					1.750				HL-64-22
				1.750					1.750				HL-64-28
				2.125					2.125				HL-64-34
0.7656 to 1.0000	1.375	1.3760	1.3756	1.750	1.770	1.765	1.7523	1.7519	2.500	0.094	1.875	0.188	HL-88-8
				1.750					1.000				HL-88-12
				1.375					1.375				HL-88-16
				2.125					1.750				HL-88-22
1.0156 to 1.3750	1.750	1.7512	1.7508	2.250	2.27	2.265	2.2525	2.2521	2.125	0.094	2.375	0.188	HL-88-28
				2.250					2.125				HL-88-34
				2.500					2.500				HL-112-12
				3.000					3.000				HL-112-16
1.3906 to 1.7500	2.250	2.2515	2.2510	2.750	2.770	2.765	2.7526	2.7522	1.000	0.125	2.875	0.188	HL-112-22
				2.750					1.750				HL-112-28
				2.125					1.750				HL-112-34
				2.500					2.500				HL-112-40
1.3906 to 1.7500	2.250	2.2515	2.2510	2.750	2.770	2.765	2.7526	2.7522	1.000	0.125	2.875	0.188	HL-144-16
				2.750					1.375				HL-144-22
				2.125					1.750				HL-144-28
				2.500					2.500				HL-144-34
1.3906 to 1.7500	2.250	2.2515	2.2510	2.750	2.770	2.765	2.7526	2.7522	1.000	0.125	2.875	0.188	HL-144-40
				2.750					1.375				HL-144-48
				2.125					1.750				HL-176-16
				2.500					2.500				HL-176-22
1.3906 to 1.7500	2.250	2.2515	2.2510	2.750	2.770	2.765	2.7526	2.7522	1.000	0.125	2.875	0.188	HL-176-28
				2.750					1.375				HL-176-34
				2.125					1.750				HL-176-40
				2.500					2.500				HL-176-48

All dimensions are in inches.

See also footnotes to Table 7.



**Table 9. American National Standard Locking Mechanisms for Jig Bushings**  
ANSI B94.33-1974, R1986

Lock Screw for Use with Slip or Fixed Renewable Bushings											
No.	A	B	C	D	E	F	UNC Thread				
LS-0	0.438	0.188	0.312	Per Manufacturer's Standard	0.188	0.105-0.100	8-32				
LS-1	0.625	0.375	0.625		0.250	0.138-0.132	5/16-18				
LS-2	0.875	0.375	0.625		0.375	0.200-0.194	3/8-18				
LS-3	1.000	0.438	0.750		0.375	0.200-0.194	7/16-16				
Round Clamp Optional Only for Use with Fixed Renewable Bushing											
Number	A	B	C	D	E	F	G	H	Use With Socket Head Screw		
RC-1	0.625	0.312	0.454	0.150	0.203	0.125	0.531	0.528	5/16-18		
RC-2	0.625	0.438	0.484	0.219	0.187	0.188	0.906	0.328	5/16-18		
RC-3	0.750	0.500	0.578	0.281	0.219	0.188	1.406	0.391	7/16-16		
Locking Mechanism Dimensions of Slip and Fixed Renewable Bushings											
Body OD	Max Diam. F When Used With Locking Device	G Head Thickness		H ± 0.005	J	L Max	R	Locking Dia. of Lock Screw (Slip or Fixed)	Locking Dia. of Clamp (Fixed Only)	Max Head Diam. of Mating Liner Used to Clear Locking Device	Clamp or Screw LS or RC
		Slip	Fixed								
0.188	0.312	0.188	0.188	0.094	0.094	55°	0.256	0.105-0.100	...	0.625	0
0.312	0.562	0.375	0.250	0.125	0.172	65°	0.500	0.138-0.132	0.125-0.115	0.625	1
0.500	0.812	0.438	0.250	0.125	0.297	65°	0.625	0.138-0.132	0.125-0.115	0.875	1
0.750	1.062	0.438	0.250	0.125	0.422	50°	0.750	0.138-0.132	0.125-0.115	1.125	1
1.000	1.438	0.438	0.375	0.188	0.594	35°	0.922	0.200-0.194	0.187-0.177	1.500	2
1.375	1.812	0.438	0.375	0.188	0.781	30°	1.109	0.200-0.194	0.187-0.177	1.875	2
1.750	2.312	0.625	0.375	0.188	1.000	30°	1.391	0.200-0.194	0.187-0.177	2.375	3
2.250	2.812	0.625	0.375	0.188	1.250	25°	1.641	0.200-0.194	0.187-0.177	2.875	3

All dimensions are in inches.

**Jig Bushing Definitions.**— *Renewable Bushings:* Renewable wearing bushings to guide the tool are for use in liners which in turn are installed in the jig. They are used where the bushing will wear out or become obsolete before the jig or where several bushings are to be interchangeable in one hole. Renewable wearing bushings are divided into two classes, "Fixed" and "Slip." Fixed renewable bushings are installed in the liner with the intention of leaving them in place until worn out. Slip renewable bushings are interchangeable in a given size of liner and, to facilitate removal, they are usually made with a knurled head. They are most frequently used where two or more operations requiring different inside diameters are performed in a single jig, such as where drilling is followed by reaming, tapping, spot facing, counterboring, or some other secondary operation.

*Press Fit Bushings:* Press fit wearing bushings to guide the tool are for installation directly in the jig without the use of a liner and are employed principally where the bushings are used for short production runs and will not require replacement. They are intended also for short center distances.

*Liner Bushings:* Liner bushings are provided with and without heads and are permanently installed in a jig to receive the renewable wearing bushings. They are sometimes called master bushings.

**Jig Plate Thickness.**—The standard length of the press fit portion of jig bushings as established are based on standardized uniform jig plate thicknesses of  $\frac{3}{16}$ ,  $\frac{3}{8}$ ,  $\frac{1}{2}$ ,  $\frac{3}{4}$ , 1,  $1\frac{1}{8}$ ,  $1\frac{1}{4}$ ,  $2\frac{1}{2}$ ,  $2\frac{1}{2}$ , and 3 inches.

**Jig Bushing Designation System.**—*Inside Diameter:* The inside diameter of the hole is specified by a decimal dimension.

*Type Bushing:* The type of bushing is specified by a letter: S for Slip Renewable, F for Fixed Renewable, L for Headless Liner, HL for Head Liner, P for Headless Press Fit, and H for Head Press Fit.

*Body Diameter:* The body diameter is specified in multiples of 0.0156 inch. For example, a 0.500-inch body diameter =  $0.500/0.0156 = 32$ .

*Body Length:* The effective or body length is specified in multiples of 0.0625 inch. For example, a 0.500-inch length =  $0.500/0.0625 = 8$ .

*Unfinished Bushings:* All bushings with grinding stock on the body diameter are designated by the letter U following the number.

*Example:* A slip renewable bushing having a hole diameter of 0.5000 inch, a body diameter of 0.750 inch, and a body length of 1.000 inch would be designated as .5000-S-48-16.

**Definition of Jig and Fixture.**—The distinction between a jig and fixture is not easy to define, but, as a general rule, it is as follows: A jig either holds or is held on the work, and, at the same time, contains guides for the various cutting tools, whereas a fixture holds the work while the cutting tools are in operation, but does not contain any special arrangements for guiding the tools. A fixture, therefore, must be securely held or fixed to the machine on which the operation is performed—hence the name. A fixture is sometimes provided with a number of gages and stops, but not with bushings or other devices for guiding and supporting the cutting tools.

**Jig Borers.**—Jig borers are used for precision hole-location work. For this reason, the coordinate measuring systems on these machines are designed to provide longitudinal and transverse movements that are accurate to 0.0001 in. One widely used method of obtaining this accuracy utilizes ultraprecision lead screws. Another measuring system employs precision end measuring rods and a micrometer head that are placed in a trough which is parallel to the table movement. However, the purpose of all coordinate measuring systems used is the same: to provide a method of aligning the spindle at the precise location where a hole is to be produced. Since the work table of a jig borer moves in two directions, the coordinate system of dimensioning is used, where dimensions are given from two perpen-

dicular reference axes, usually the sides of the workpiece, frequently its upper left-hand corner. See Fig. 1C.

**Jig-Boring Practice.**—The four basic steps to follow to locate and machine a hole on a jig borer are: 1) align and clamp the workpiece on the jig-borer table; 2) locate the two reference axes of the workpiece with respect to the jig-borer spindle; 3) locate the hole to be machined; and 4) drill and bore the hole to size.

*Align and Clamp the Workpiece:* The first consideration in placing the workpiece on the jig-borer table should be the relation of the coordinate measuring system of the jig borer to the coordinate dimensions on the drawing. Therefore, the coordinate measuring system is designed so that the readings of the coordinate measurements are direct when the table is moved toward the left and when it is moved toward the column of the jig borer. The result would be the same if the spindle were moved toward the right and away from the column, with the workpiece situated in such a position that one reference axis is located at the left and the other axis at the back, toward the column.

If the holes to be bored are to pass through the bottom of the workpiece, then the workpiece must be placed on precision parallel bars. In order to prevent the force exerted by the clamps from bending the workpiece the parallel bars are placed directly under the clamps, which hold the workpiece on the table. The reference axes of the workpiece must also be aligned with respect to the transverse and longitudinal table movements before it is firmly clamped. This alignment can be done with a dial-test indicator held in the spindle of the jig borer and bearing against the longitudinal reference edge. As the table is traversed in the longitudinal direction, the workpiece is adjusted until the dial-test indicator readings are the same for all positions.

*Locate the Two Reference Axes of the Workpiece with Respect to the Spindle:* The jig-borer table is now moved to position the workpiece in a precise and known location from where it can be moved again to the location of the holes to be machined. Since all the holes are dimensioned from the two reference axes, the most convenient position to start from is where the axis of the jig-borer spindle and the intersection of the two workpiece reference axes are aligned. This is called the starting position, which is similar to a zero reference position. When so positioned, the longitudinal and transverse measuring systems of the jig borer are set to read zero. Occasionally, the reference axes are located outside the body of the workpiece: a convenient edge or hole on the workpiece is picked up as the starting position, and the dimensions from this point to the reference axes are set on the positioning measuring system.

*Locate the Hole:* Precise coordinate table movements are used to position the workpiece so that the spindle axis is located exactly where the hole is to be machined. When the measuring system has been set to zero at the starting position, the coordinate readings at the hole location will be the same as the coordinate dimensions of the hole center.

The movements to each hole must be made in one direction for both the transverse and longitudinal directions, to eliminate the effect of any backlash in the lead screw. The usual table movements are toward the left and toward the column.

The most convenient sequence on machines using micrometer dials as position indicators (machines with lead screws) is to machine the hole closest to the starting position first and then the next closest, and so on. On jig borers using end measuring rods, the opposite sequence is followed: The farthest hole is machined first and then the next farthest, and so on, since it is easier to remove end rods and replace them with shorter rods.

*Drill and Bore Hole to Size:* The sequence of operations used to produce a hole on a jig borer is as follows: 1) a short, stiff drill, such as a center drill, that will not deflect when cutting should be used to spot a hole when the work and the axis of the machine tool spindle are located at the exact position where the hole is wanted; 2) the initial hole is made by a twist drill; and 3) a single-point boring tool that is set to rotate about the axis of the machine tool spindle is then used to generate a cut surface that is concentric to the axis of rotation.

Heat will be generated by the drilling operation, so it is good practice to drill all the holes first, and then allow the workpiece to cool before the holes are bored to size.

**Transfer of Tolerances.**—All of the dimensions that must be accurately held on precision machines and engine parts are usually given a tolerance. And when such dimensions are changed from the conventional to the coordinate system of dimensioning, the tolerances must also be included. Because of their importance, the transfer of the tolerances must be done with great care, keeping in mind that the sum of the tolerances of any pair of dimensions in the coordinate system must not be larger than the tolerance of the dimension that they replaced in the conventional system. An example is given in Fig. 1.

The first step in the procedure is to change the tolerances given in Fig. 1A to equal, bilateral tolerances given in Fig. 1B. For example, the dimension  $2.125^{+0.003}_{-0.001}$  has a total tolerance of 0.004. The equal, bilateral tolerance would be plus or minus one-half of this value, or  $\pm 0.002$ . Then to keep the limiting dimensions the same, the basic dimension must be changed to 2.126, in order to give the required values of 2.128 and 2.124. When changing to equal, bilateral tolerances, if the upper tolerance is decreased (as in this example), the basic dimension must be increased by a like amount. The upper tolerance was decreased by  $0.003 - 0.002 = 0.001$ ; therefore, the basic dimension was increased by 0.001 to 2.126. Conversely, if the upper tolerance is increased, the basic dimension is decreased.

The next step is to transfer the revised basic dimension to the coordinate dimensioning system. To transfer the 2.126 dimension, the distance of the applicable holes from the left reference axis must be determined. The first holes to the right are 0.8750 from the reference axis. The second hole is 2.126 to the right of the first holes. Therefore, the second hole is  $0.8750 + 2.126 = 3.0010$  to the right of the reference axis. This value is then the coordinate dimension for the second hole, while the 0.8750 value is the coordinate dimension of the first two, vertically aligned holes. This procedure is followed for all the holes to find their distances from the two reference axes. These values are given in Fig. 1C.

The final step is to transfer the tolerances. The 2.126 value in Fig. 1B has been replaced by the 0.8750 and 3.0010 values in Fig. 1C. The 2.126 value has an available tolerance of  $\pm 0.002$ . Dividing this amount equally between the two replacement values gives  $0.8750 \pm 0.001$  and  $3.0010 \pm 0.001$ . The sum of these tolerances is .002, and as required, does not exceed the tolerance that was replaced. Next transfer the tolerance of the 0.502 dimension. Divide the available tolerance,  $\pm 0.002$ , equally between the two replacement values to yield  $3.0010 \pm 0.001$  and  $3.5030 \pm 0.001$ . The sum of these two tolerances equals the replaced tolerance, as required. However, the 1.125 value of the last hole to the right (coordinate dimension 4.6280 in.) has a tolerance of only  $\pm 0.001$ . Therefore, the sum of the tolerances on the 3.5030 and 4.6280 values cannot be larger than 0.001. Dividing this tolerance equally would give  $3.5030 \pm .0005$  and  $4.6280 \pm 0.0005$ . This new, smaller tolerance replaces the  $\pm 0.001$  tolerance on the 3.5030 value in order to satisfy all tolerance sum requirements. This example shows how the tolerance of a coordinate value is affected by more than one other dimensional requirement.

JIG BORING

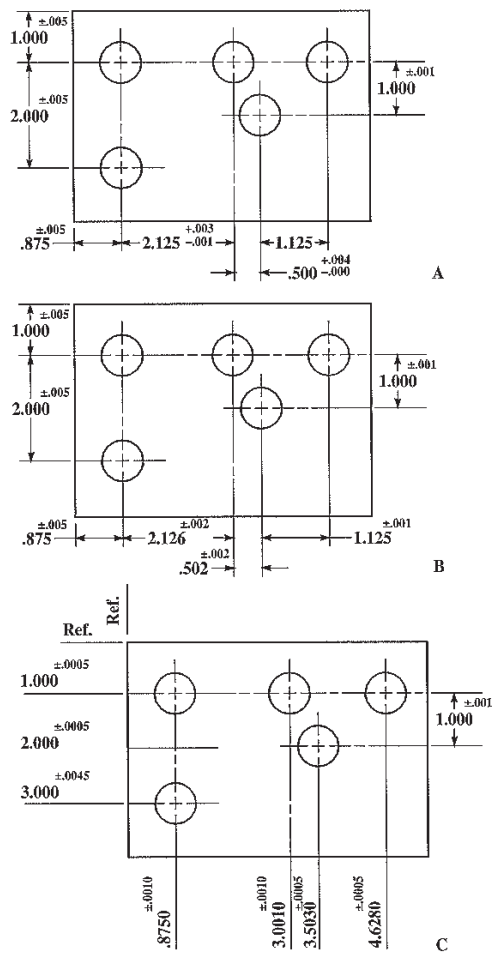

Fig. 1. (A) Conventional Dimensions, Mixed Tolerances; (B) Conventional Dimensions, All Equal, Bilateral Tolerances; and (C) Coordinate Dimensions

The following discussion will summarize the various tolerances listed in Fig. 1C. For the  $0.8750 \pm 0.0010$  dimension, the  $\pm 0.0010$  tolerance together with the  $\pm 0.0010$  tolerance on the  $3.0010$  dimension is required to maintain the  $\pm 0.002$  tolerance of the  $2.126$  dimension. The  $\pm .0005$  tolerances on the  $3.5030$  and  $4.2680$  dimensions are required to maintain the  $\pm 0.001$  tolerance of the  $1.125$  dimension, at the same time as the sum of the  $\pm .0005$  tolerance on the  $3.5030$  dimension and the  $\pm 0.001$  tolerance on the  $3.0010$  dimension does not exceed the  $\pm 0.002$  tolerance on the replaced  $0.503$  dimension. The  $\pm 0.0005$  tolerances on the  $1.0000$  and  $2.0000$  values maintain the  $\pm 0.001$  tolerance on the  $1.0000$  value given at the right in Fig. 1A. The  $\pm 0.0045$  tolerance on the  $3.0000$  dimension together with the  $\pm 0.0005$  tolerance on the  $1.0000$  value maintains the  $\pm .005$  tolerance on the  $2.0000$  dimension of Fig. 1A. It should be noted that the  $2.000 \pm .005$  dimension in Fig. 1A was replaced by the  $1.0000$  and  $3.0000$  dimensions in Fig. 1C. Each of these values could have had a tolerance of  $\pm 0.0025$ , except that the tolerance on the  $1.0000$  dimension on the left in Fig. 1A is also bound by the  $\pm 0.001$  tolerance on the  $1.0000$  dimension on the right, thus the  $\pm 0.0005$  tolerance value is used. This procedure requires the tolerance on the  $3.0000$  value to be increased to  $\pm 0.0045$ .

#### Lengths of Chords for Spacing Off the Circumferences of Circles

On the following pages are given tables of the lengths of chords for spacing off the circumferences of circles. The object of these tables is to make possible the division of the periphery into a number of equal parts without trials with the dividers. The first table is calculated for circles having a diameter equal to 1. For circles of other diameters, the length of chord given in the table should be multiplied by the diameter of the circle. This first table may be used by toolmakers when setting "buttons" in circular formation. Assume that it is required to divide the periphery of a circle of 20 inches diameter into thirty-two equal parts. From the table the length of the chord is found to be 0.098017 inch, if the diameter of the circle were 1 inch. With a diameter of 20 inches the length of the chord for one division would be  $20 \times 0.098017 = 1.9603$  inches. Another example in metric units: For a 100 millimeter diameter requiring 5 equal divisions, the length of the chord for one division would be  $100 \times 0.587785 = 58.7785$  millimeters.

The two following pages give an additional table for the spacing off of circles, the table, in this case, being worked out for diameters from  $\frac{1}{16}$  inch to 14 inches. As an example, assume that it is required to divide a circle having a diameter of  $6\frac{1}{2}$  inches into seven equal parts. Find first, in the column headed "6" and in line with 7 divisions, the length of the chord for a 6-inch circle, which is 2.603 inches. Then find the length of the chord for a  $\frac{1}{2}$ -inch diameter circle, 7 divisions, which is 0.217. The sum of these two values,  $2.603 + 0.217 = 2.820$  inches, is the length of the chord required for spacing off the circumference of a  $6\frac{1}{2}$ -inch circle into seven equal divisions.

As another example, assume that it is required to divide a circle having a diameter of  $9\frac{23}{32}$  inches into 15 equal divisions. First find the length of the chord for a 9-inch circle, which is 1.871 inch. The length of the chord for a  $\frac{23}{32}$ -inch circle can easily be estimated from the table by taking the value that is exactly between those given for  $\frac{11}{16}$  and  $\frac{3}{4}$  inch. The value for  $\frac{11}{16}$  inch is 0.143, and for  $\frac{3}{4}$  inch, 0.156. For  $\frac{23}{32}$ , the value would be 0.150. Then,  $1.871 + 0.150 = 2.021$  inches.

**Lengths of Chords for Spacing Off the Circumferences of Circles with a Diameter Equal to 1 (English or metric units)**

No. of Spaces	Length of Chord	No. of Spaces	Length of Chord	No. of Spaces	Length of Chord	No. of Spaces	Length of Chord
3	0.866025	22	0.142315	41	0.076549	60	0.052336
4	0.707107	23	0.136167	42	0.074730	61	0.051479
5	0.587785	24	0.130526	43	0.072995	62	0.050649
6	0.500000	25	0.125333	44	0.071339	63	0.049846
7	0.433884	26	0.120537	45	0.069756	64	0.049068
8	0.382683	27	0.116093	46	0.068242	65	0.048313
9	0.342020	28	0.111964	47	0.066793	66	0.047582
10	0.309017	29	0.108119	48	0.065403	67	0.046872
11	0.281733	30	0.104528	49	0.064070	68	0.046183
12	0.258819	31	0.101168	50	0.062791	69	0.045515
13	0.239316	32	0.098017	51	0.061561	70	0.044865
14	0.222521	33	0.095056	52	0.060378	71	0.044233
15	0.207912	34	0.092268	53	0.059241	72	0.043619
16	0.195090	35	0.089639	54	0.058145	73	0.043022
17	0.183750	36	0.087156	55	0.057089	74	0.042441
18	0.173648	37	0.084806	56	0.056070	75	0.041876
19	0.164595	38	0.082579	57	0.055088	76	0.041325
20	0.156434	39	0.080467	58	0.054139	77	0.040789
21	0.149042	40	0.078459	59	0.053222	78	0.040266

For circles of other diameters, multiply length given in table by diameter of circle.

**Hole Coordinate Dimension Factors for Jig Boring.**—Tables of hole coordinate dimension factors for use in jig boring are given in Tables 1 through 4 starting on page 959. The coordinate axes shown in the figure accompanying each table are used to reference the tool path; the values listed in each table are for the end points of the tool path. In this machine coordinate system, a positive *Y* value indicates that the effective motion of the tool with reference to the work is toward the front of the jig borer (the actual motion of the jig borer table is toward the column). Similarly, a positive *X* value indicates that the effective motion of the tool with respect to the work is toward the right (the actual motion of the jig borer table is toward the left). When entering data into most computer-controlled jig borers, current practice is to use the more familiar Cartesian coordinate axis system in which the positive *Y* direction is "up" (i.e., pointing toward the column of the jig borer). The computer will automatically change the signs of the entered *Y* values to the signs that they would have in the machine coordinate system. Therefore, before applying the coordinate dimension factors given in the tables, it is important to determine the coordinate system to be used. If a Cartesian coordinate system is to be used for the tool path, then the sign of the *Y* values in the tables must be changed, from positive to negative and from negative to positive. For example, when programming for a three-hole type *A* circle using Cartesian coordinates, the *Y* values from Table 3 would be  $y_1 = +0.50000$ ,  $y_2 = -0.25000$ , and  $y_3 = -0.25000$ .

Table 10. Table for Spacing Off the Circumferences of Circles

No. of Divisions	Degrees in Arc	Diameter of Circle to be Spaced Off														
		1/8	1/4	3/8	1/2	5/8	3/4	7/8	1	1 1/8	1 1/4	1 3/8	1 1/2			
3	120	0.054	0.108	0.162	0.217	0.271	0.325	0.379	0.433	0.487	0.541	0.595	0.630	0.704	0.758	0.812
4	90	0.044	0.088	0.133	0.177	0.221	0.265	0.309	0.354	0.398	0.442	0.486	0.530	0.575	0.619	0.663
5	72	0.037	0.073	0.110	0.147	0.184	0.220	0.257	0.294	0.331	0.367	0.404	0.441	0.478	0.514	0.551
6	60	0.031	0.063	0.094	0.125	0.156	0.188	0.219	0.250	0.281	0.313	0.344	0.375	0.406	0.438	0.469
7	51 3/4	0.027	0.054	0.081	0.108	0.136	0.163	0.190	0.217	0.244	0.271	0.298	0.325	0.353	0.380	0.407
8	45	0.024	0.048	0.072	0.096	0.120	0.144	0.167	0.191	0.215	0.239	0.263	0.287	0.311	0.335	0.359
9	40	0.021	0.043	0.064	0.086	0.107	0.128	0.150	0.171	0.192	0.214	0.235	0.257	0.278	0.299	0.321
10	36	0.019	0.039	0.058	0.077	0.097	0.116	0.135	0.155	0.174	0.193	0.212	0.232	0.251	0.270	0.290
11	32 1/2	0.018	0.035	0.053	0.070	0.088	0.106	0.123	0.141	0.158	0.176	0.194	0.211	0.229	0.247	0.264
12	30	0.016	0.032	0.049	0.066	0.081	0.097	0.113	0.129	0.146	0.162	0.178	0.194	0.210	0.226	0.243
13	27 3/4	0.015	0.030	0.045	0.060	0.075	0.090	0.105	0.120	0.135	0.150	0.165	0.179	0.194	0.209	0.224
14	24	0.014	0.028	0.042	0.056	0.069	0.083	0.097	0.111	0.125	0.139	0.153	0.167	0.181	0.195	0.209
15	23 1/2	0.013	0.026	0.039	0.052	0.065	0.078	0.091	0.104	0.117	0.130	0.143	0.156	0.169	0.182	0.195
16	21 3/4	0.012	0.024	0.037	0.050	0.063	0.076	0.089	0.102	0.115	0.128	0.141	0.154	0.167	0.180	0.193
17	21 1/2	0.011	0.022	0.033	0.044	0.055	0.066	0.077	0.088	0.099	0.109	0.119	0.130	0.141	0.152	0.163
18	18 3/4	0.010	0.021	0.031	0.041	0.051	0.062	0.072	0.082	0.093	0.103	0.113	0.123	0.134	0.144	0.154
19	18	0.010	0.020	0.030	0.039	0.049	0.059	0.068	0.078	0.088	0.098	0.108	0.117	0.127	0.137	0.147
20	17 1/2	0.009	0.019	0.028	0.037	0.047	0.056	0.065	0.075	0.084	0.094	0.102	0.112	0.121	0.130	0.140
21	16 3/4	0.009	0.018	0.027	0.036	0.044	0.053	0.062	0.071	0.080	0.089	0.098	0.107	0.116	0.125	0.133
22	16 1/4	0.009	0.017	0.026	0.034	0.043	0.051	0.059	0.067	0.075	0.082	0.090	0.098	0.106	0.114	0.122
23	15 3/4	0.008	0.016	0.024	0.033	0.041	0.049	0.057	0.065	0.073	0.081	0.088	0.096	0.102	0.110	0.117
24	14 3/4	0.008	0.016	0.023	0.031	0.039	0.047	0.055	0.063	0.070	0.078	0.086	0.094	0.102	0.110	0.117
25	14 1/4	0.008	0.015	0.023	0.030	0.038	0.045	0.053	0.060	0.068	0.075	0.083	0.090	0.098	0.105	0.113
26	13 3/4	0.007	0.014	0.021	0.028	0.035	0.042	0.049	0.056	0.063	0.070	0.077	0.084	0.091	0.098	0.105
28	12 3/4	0.007	0.013	0.020	0.026	0.033	0.039	0.046	0.052	0.059	0.065	0.072	0.078	0.085	0.091	0.098
30	12	0.006	0.012	0.018	0.025	0.031	0.037	0.043	0.049	0.055	0.061	0.067	0.073	0.078	0.085	0.091
32	11 1/4	0.006	0.012	0.018	0.025	0.031	0.037	0.043	0.049	0.055	0.061	0.067	0.073	0.078	0.085	0.091

See Lengths of Chords for Spacing Off the Circumferences of Circles on page 955 for explanatory matter.



Table for Spacing Off the Circumferences of Circles

No. of Divisions	Degrees in Arc	Diameter of Circle to be Spaced Off													
		1	2	3	4	5	6	7	8	9	10	11	12	13	14
3	120°	0.866	1.732	2.598	3.464	4.330	5.196	6.062	6.928	7.794	8.660	9.526	10.392	11.258	12.124
4	90°	0.707	1.414	2.121	2.828	3.536	4.243	4.950	5.657	6.364	7.071	7.778	8.485	9.192	9.899
5	72°	0.588	1.176	1.763	2.351	2.939	3.527	4.114	4.702	5.290	5.878	6.466	7.053	7.641	8.229
6	60°	0.500	1.000	1.500	2.000	2.500	3.000	3.500	4.000	4.500	5.000	5.500	6.000	6.500	7.000
7	51½°	0.434	0.868	1.302	1.736	2.169	2.603	3.037	3.471	3.905	4.339	4.773	5.207	5.640	6.074
8	45°	0.383	0.765	1.148	1.531	1.913	2.296	2.679	3.061	3.444	3.827	4.210	4.592	4.975	5.358
9	40°	0.342	0.684	1.026	1.368	1.710	2.052	2.394	2.736	3.078	3.420	3.762	4.104	4.446	4.788
10	36°	0.309	0.618	0.927	1.236	1.545	1.854	2.163	2.472	2.781	3.090	3.399	3.708	4.017	4.326
11	32½°	0.282	0.563	0.845	1.127	1.409	1.690	1.972	2.254	2.536	2.817	3.099	3.381	3.663	3.944
12	30°	0.259	0.518	0.775	1.035	1.294	1.553	1.812	2.071	2.329	2.588	2.847	3.106	3.365	3.623
13	27½°	0.239	0.479	0.718	0.957	1.197	1.436	1.675	1.915	2.154	2.393	2.632	2.872	3.111	3.350
14	25½°	0.223	0.445	0.668	0.890	1.113	1.335	1.558	1.780	2.003	2.225	2.448	2.670	2.893	3.115
15	24°	0.208	0.416	0.624	0.832	1.040	1.247	1.455	1.663	1.871	2.079	2.287	2.495	2.703	2.911
16	22½°	0.195	0.390	0.585	0.780	0.975	1.171	1.366	1.561	1.756	1.951	2.146	2.341	2.536	2.731
17	21½°	0.184	0.367	0.551	0.735	0.919	1.102	1.286	1.470	1.654	1.837	2.021	2.205	2.389	2.572
18	20°	0.174	0.347	0.521	0.695	0.868	1.042	1.216	1.389	1.563	1.736	1.910	2.084	2.257	2.431
19	18½°	0.165	0.329	0.494	0.658	0.823	0.988	1.152	1.317	1.481	1.646	1.811	1.975	2.140	2.304
20	18°	0.156	0.313	0.469	0.626	0.782	0.939	1.095	1.251	1.408	1.564	1.721	1.877	2.034	2.190
21	17½°	0.149	0.298	0.447	0.596	0.745	0.894	1.043	1.192	1.341	1.490	1.639	1.789	1.938	2.087
22	16½°	0.142	0.285	0.427	0.569	0.712	0.854	0.996	1.139	1.281	1.423	1.565	1.708	1.850	1.992
23	15½°	0.136	0.272	0.408	0.545	0.681	0.817	0.953	1.089	1.225	1.362	1.498	1.634	1.770	1.906
24	15°	0.131	0.261	0.392	0.522	0.653	0.783	0.914	1.044	1.175	1.305	1.436	1.566	1.697	1.827
25	14½°	0.125	0.251	0.376	0.501	0.627	0.752	0.877	1.003	1.128	1.253	1.379	1.504	1.629	1.755
26	13½°	0.121	0.241	0.362	0.482	0.603	0.723	0.844	0.964	1.085	1.205	1.325	1.446	1.567	1.688
28	12½°	0.112	0.224	0.336	0.448	0.560	0.672	0.784	0.896	1.008	1.120	1.232	1.344	1.456	1.568
30	12°	0.105	0.209	0.314	0.418	0.523	0.627	0.732	0.836	0.941	1.045	1.150	1.254	1.359	1.463
32	11½°	0.098	0.196	0.294	0.392	0.490	0.588	0.686	0.784	0.882	0.980	1.078	1.176	1.274	1.372

**Table 1. Hole Coordinate Dimension Factors for Jig Boring — Type "A" Hole Circles (English or Metric Units)**

3 Holes		4 Holes		5 Holes		6 Holes		7 Holes		8 Holes		9 Holes	
x1	0.50000	x1	0.50000	x1	0.50000	x1	0.50000	x1	0.50000	x1	0.50000	x1	0.50000
y1	0.00000	y1	0.00000	y1	0.00000	y1	0.00000	y1	0.00000	y1	0.00000	y1	0.00000
x2	0.06699	x2	0.00000	x2	0.20447	x2	0.06699	x2	0.10908	x2	0.14645	x2	0.17861
y2	0.75000	y2	0.50000	y2	0.34549	y2	0.25000	y2	0.18826	y2	0.14645	y2	0.11698
x3	0.93301	x3	0.50000	x3	0.20611	x3	0.06699	x3	0.01254	x3	0.00000	x3	0.00760
y3	0.75000	y3	1.00000	y3	0.90451	y3	0.75000	y3	0.61126	y3	0.50000	y3	0.41318
		y4	1.00000	y4	0.79389	y4	0.50000	y4	0.28306	y4	0.14645	y4	0.06699
		y4	0.50000	y4	0.90451	y4	1.00000	y4	0.95048	y4	0.85355	y4	0.75000
				x5	0.97553	x5	0.93301	x5	0.71694	x5	0.50000	x5	0.32899
				y5	0.34549	y5	0.75000	y5	0.95048	y5	1.00000	y5	0.96985
						x6	0.93301	x6	0.98746	x6	0.85355	x6	0.67101
						y6	0.25000	y6	0.61136	y6	0.85355	y6	0.96985
								x7	0.89092	x7	1.00000	x7	0.93301
								y7	0.18826	y7	0.50000	y7	0.75000
										x8	0.85355	x8	0.59240
										y8	0.14645	y8	0.41318
												x9	0.82139
												y9	0.11698
10 Holes		11 Holes		12 Holes		13 Holes		14 Holes		15 Holes		16 Holes	
x1	0.50000	x1	0.50000	x1	0.50000	x1	0.50000	x1	0.50000	x1	0.50000	x1	0.50000
y1	0.00000	y1	0.00000	y1	0.00000	y1	0.00000	y1	0.00000	y1	0.00000	y1	0.00000
x2	0.20611	x2	0.22968	x2	0.25000	x2	0.26764	x2	0.28306	x2	0.29863	x2	0.30866
y2	0.08549	y2	0.07937	y2	0.06699	y2	0.05727	y2	0.04952	y2	0.04323	y2	0.03806
x3	0.02447	x3	0.04518	x3	0.06699	x3	0.08851	x3	0.10908	x3	0.12843	x3	0.14645
y3	0.34549	y3	0.29229	y3	0.25000	y3	0.21597	y3	0.18826	y3	0.16543	y3	0.14645
x4	0.02447	x4	0.00509	x4	0.00000	x4	0.00365	x4	0.01254	x4	0.02447	x4	0.03806
y4	0.65451	y4	0.57116	y4	0.50000	y4	0.43973	y4	0.38874	y4	0.34549	y4	0.30866
x5	0.20611	x5	0.12213	x5	0.06699	x5	0.03249	x5	0.01254	x5	0.00274	x5	0.00000
y5	0.90451	y5	0.82743	y5	0.75000	y5	0.67730	y5	0.61126	y5	0.55226	y5	0.50000
x6	0.50000	x6	0.35913	x6	0.25000	x6	0.16844	x6	0.10908	x6	0.06699	x6	0.03806
y6	1.00000	y6	0.97975	y6	0.93301	y6	0.87426	y6	0.81174	y6	0.75000	y6	0.69134
x7	0.79389	x7	0.64087	x7	0.50000	x7	0.38034	x7	0.28306	x7	0.20611	x7	0.14645
y7	0.90451	y7	0.97975	y7	1.00000	y7	0.98547	y7	0.95048	y7	0.90451	y7	0.85355
x8	0.97553	x8	0.87787	x8	0.75000	x8	0.61966	x8	0.50000	x8	0.39604	x8	0.30866
y8	0.65451	y8	0.82743	y8	0.93301	y8	0.98547	y8	1.00000	y8	0.98907	y8	0.96194
x9	0.97553	x9	0.99491	x9	0.93301	x9	0.83156	x9	0.71694	x9	0.60396	x9	0.50000
y9	0.34549	y9	0.57116	y9	0.75000	y9	0.87426	y9	0.95048	y9	0.98907	y9	1.00000
x10	0.79389	x10	0.85482	x10	1.00000	x10	0.96751	x10	0.89092	x10	0.79389	x10	0.69134
y10	0.06549	y10	0.29229	y10	0.50000	y10	0.67730	y10	0.81174	y10	0.90451	y10	0.96194
		x11	0.77032	x11	0.93801	x11	0.99635	x11	0.98746	x11	0.93301	x11	0.85355
		y11	0.07937	y11	0.25000	y11	0.43973	y11	0.61126	y11	0.75000	y11	0.85355
				x12	0.75000	x12	0.91149	x12	0.98746	x12	0.99726	x12	0.96194
				y12	0.06699	y12	0.21597	y12	0.38874	y12	0.55226	y12	0.69134
						x13	0.73236	x13	0.89092	x13	0.97553	x13	1.00000
						y13	0.05727	y13	0.18826	y13	0.34549	y13	0.50000
								x14	0.71694	x14	0.87157	x14	0.96194
								y14	0.04952	y14	0.16543	y14	0.30866
										x15	0.70337	x15	0.85355
										y15	0.04323	y15	0.14645
												x16	0.69134
												y16	0.03806

**Table 1. (Continued) Hole Coordinate Dimension Factors for Jig Boring — Type "A" Hole Circles (English or Metric Units)**

17 Holes		18 Holes		19 Holes		20 Holes		21 Holes		22 Holes		23 Holes	
x1	0.50000	x1	0.50000	x1	0.50000	x1	0.50000	x1	0.50000	x1	0.50000	x1	0.50000
y1	0.00000	y1	0.00000	y1	0.00000	y1	0.00000	y1	0.00000	y1	0.00000	y1	0.00000
x2	0.31938	x2	0.32899	x2	0.33765	x2	0.34549	x2	0.35262	x2	0.35913	x2	0.36510
y2	0.03376	y2	0.03015	y2	0.02709	y2	0.02447	y2	0.02221	y2	0.02025	y2	0.01854
x3	0.16315	x3	0.17861	x3	0.19289	x3	0.20611	x3	0.21834	x3	0.22968	x3	0.24021
y3	0.13050	y3	0.11698	y3	0.10543	y3	0.09549	y3	0.08688	y3	0.07937	y3	0.07279
x4	0.05242	x4	0.06699	x4	0.08142	x4	0.09549	x4	0.10908	x4	0.12213	x4	0.13458
y4	0.27713	y4	0.25000	y4	0.22653	y4	0.20611	y4	0.18826	y4	0.17257	y4	0.15872
x5	0.03213	x5	0.00760	x5	0.01530	x5	0.02447	x5	0.03456	x5	0.04518	x5	0.05606
y5	0.45387	y5	0.41318	y5	0.37726	y5	0.34549	y5	0.31733	y5	0.29229	y5	0.26997
x6	0.01909	x6	0.00760	x6	0.00171	x6	0.00000	x6	0.00140	x6	0.00509	x6	0.01046
y6	0.63683	y6	0.58682	y6	0.54129	y6	0.50000	y6	0.46263	y6	0.42884	y6	0.39827
x7	0.10099	x7	0.06699	x7	0.04211	x7	0.02447	x7	0.01254	x7	0.00509	x7	0.00117
y7	0.80132	y7	0.75000	y7	0.70085	y7	0.65451	y7	0.61126	y7	0.57116	y7	0.53412
x8	0.23678	x8	0.17861	x8	0.12124	x8	0.09549	x8	0.06699	x8	0.04518	x8	0.02837
y8	0.92511	y8	0.88302	y8	0.83864	y8	0.79389	y8	0.75000	y8	0.70771	y8	0.66744
x9	0.40813	x9	0.32899	x9	0.26203	x9	0.20611	x9	0.15991	x9	0.12213	x9	0.09152
y9	0.99149	y9	0.96985	y9	0.93974	y9	0.90451	y9	0.86653	y9	0.82743	y9	0.78834
x10	0.59187	x10	0.50000	x10	0.41770	x10	0.34549	x10	0.28306	x10	0.22968	x10	0.18446
y10	0.99149	y10	1.00000	y10	0.99318	y10	0.97553	y10	0.95048	y10	0.92063	y10	0.88786
x11	0.76322	x11	0.67101	x11	0.58230	x11	0.50000	x11	0.42548	x11	0.35913	x11	0.30080
y11	0.92511	y11	0.96985	y11	0.99318	y11	1.00000	y11	0.99442	y11	0.97975	y11	0.95861
x12	0.89901	x12	0.82139	x12	0.73797	x12	0.65451	x12	0.57452	x12	0.50000	x12	0.43192
y12	0.80132	y12	0.88302	y12	0.93974	y12	0.97553	y12	0.99442	y12	1.00000	y12	0.99534
x13	0.98091	x13	0.93301	x13	0.86786	x13	0.79389	x13	0.71694	x13	0.64087	x13	0.56808
y13	0.63683	y13	0.75000	y13	0.83864	y13	0.90451	y13	0.95048	y13	0.97975	y13	0.99534
x14	0.99787	x14	0.99240	x14	0.95789	x14	0.90451	x14	0.84009	x14	0.77032	x14	0.69920
y14	0.45387	y14	0.58682	y14	0.70085	y14	0.79389	y14	0.86653	y14	0.92063	y14	0.95861
x15	0.94758	x15	0.99240	x15	0.99829	x15	0.97553	x15	0.93301	x15	0.87787	x15	0.81554
y15	0.27713	y15	0.41318	y15	0.54129	y15	0.65451	y15	0.75000	y15	0.82743	y15	0.88786
x16	0.83685	x16	0.93301	x16	0.98470	x16	1.00000	x16	0.98746	x16	0.95482	x16	0.90848
y16	0.13050	y16	0.25000	y16	0.37726	y16	0.50000	y16	0.61126	y16	0.70771	y16	0.78834
x17	0.68062	x17	0.82139	x17	0.91858	x17	0.97553	x17	0.99860	x17	0.99491	x17	0.97113
y17	0.03376	y17	0.11698	y17	0.22658	y17	0.34549	y17	0.46263	y17	0.57116	y17	0.66744
		x18	0.67101	x18	0.80711	x18	0.90451	x18	0.96544	x18	0.99491	x18	0.99883
		y18	0.03015	y18	0.10543	y18	0.20611	y18	0.31733	y18	0.42884	y18	0.53412
				x19	0.66235	x19	0.79389	x19	0.89092	x19	0.95482	x19	0.98954
				y19	0.02709	y19	0.09549	y19	0.18826	y19	0.29229	y19	0.39827
						x20	0.65451	x20	0.78166	x20	0.87787	x20	0.94394
						y20	0.02447	y20	0.08688	y20	0.17257	y20	0.26997
								x21	0.64738	x21	0.77032	x21	0.85542
								y21	0.02221	y21	0.07937	y21	0.15872
										x22	0.64087	x22	0.75979
										y22	0.02025	y22	0.07279
												x23	0.63490
												y23	0.01854
24 Holes		25 Holes		26 Holes		27 Holes		28 Holes					
x1	0.50000	x1	0.50000	x1	0.50000	x1	0.50000	x1	0.50000				
y1	0.00000	y1	0.00000	y1	0.00000	y1	0.00000	y1	0.00000				
x2	0.37059	x2	0.37566	x2	0.38034	x2	0.38466	x2	0.38874				
y2	0.01704	y2	0.01571	y2	0.01453	y2	0.01348	y2	0.01254				
x3	0.25000	x3	0.25912	x3	0.26764	x3	0.27560	x3	0.28306				

**Table 1. (Continued) Hole Coordinate Dimension Factors for Jig Boring — Type "A" Hole Circles (English or Metric Units)**

		The diagram shows a type "A" circle for a 5-hole circle. Coordinates x, y are given in the table for hole circles of from 3 to 28 holes. Dimensions are for holes numbered in a counterclockwise direction (as shown). Dimensions given are based upon a hole circle of unit diameter. For a hole circle of, say, 3-inch or 3-centimeter diameter, multiply table values by 3.							
y3	0.06699	y3	0.06185	y3	0.05727	y3	0.05318	y3	0.04952
x4	0.14645	x4	0.15773	x4	0.16844	x4	0.17861	x4	0.18826
y4	0.14645	y4	0.13552	y4	0.12574	y4	0.11698	y4	0.10908
x5	0.06699	x5	0.07784	x5	0.08851	x5	0.09894	x5	0.10908
y5	0.25000	y5	0.25209	y5	0.21597	y5	0.20142	y5	0.18826
x6	0.01704	x6	0.02447	x6	0.03249	x6	0.04089	x6	0.04952
y6	0.37059	y6	0.34549	y6	0.32270	y6	0.30196	y6	0.28306
x7	0.00000	x7	0.00089	x7	0.00365	x7	0.00760	x7	0.01254
y7	0.50000	y7	0.46860	y7	0.43973	y7	0.41318	y7	0.38874
x8	0.01704	x8	0.00886	x8	0.00365	x8	0.00085	x8	0.00000
y8	0.62941	y8	0.59369	y8	0.56027	y8	0.52907	y8	0.50000
x9	0.06699	x9	0.04759	x9	0.03249	x9	0.02101	x9	0.01254
y9	0.75000	y9	0.71289	y9	0.67730	y9	0.64340	y9	0.61126
x10	0.14645	x10	0.11474	x10	0.08851	x10	0.06699	x10	0.04952
y10	0.85355	y10	0.81871	y10	0.78403	y10	0.75000	y10	0.71694
x11	0.25000	x11	0.20611	x11	0.16844	x11	0.13631	x11	0.10908
y11	0.93301	y11	0.90451	y11	0.87426	y11	0.84312	y11	0.81174
x12	0.37059	x12	0.31594	x12	0.26764	x12	0.22525	x12	0.18826
y12	0.98296	y12	0.96489	y12	0.94273	y12	0.91774	y12	0.89092
x13	0.50000	x13	0.43733	x13	0.38034	x13	0.32899	x13	0.28306
y13	1.00000	y13	0.99606	y13	0.98547	y13	0.96985	y13	0.95048
x14	0.62941	x14	0.56267	x14	0.50000	x14	0.44195	x14	0.38874
y14	0.98296	y14	0.99606	y14	1.00000	y14	0.99602	y14	0.98746
x15	0.75000	x15	0.68406	x15	0.61966	x15	0.55825	x15	0.50000
y15	0.93301	y15	0.96489	y15	0.98547	y15	0.99662	y15	1.00000
x16	0.85355	x16	0.79389	x16	0.73236	x16	0.67101	x16	0.61126
y16	0.85355	y16	0.90451	y16	0.94273	y16	0.96985	y16	0.98746
x17	0.93301	x17	0.88526	x17	0.83156	x17	0.77475	x17	0.71694
y17	0.75000	y17	0.81871	y17	0.87426	y17	0.91774	y17	0.95048
x18	0.98296	x18	0.95241	x18	0.91149	x18	0.86369	x18	0.81174
y18	0.62941	y18	0.71289	y18	0.78403	y18	0.84312	y18	0.89092
x19	1.00000	x19	0.99114	x19	0.96751	x19	0.93301	x19	0.89092
y19	0.50000	y19	0.59369	y19	0.67730	y19	0.75000	y19	0.81174
x20	0.98296	x20	0.99901	x20	0.99635	x20	0.97899	x20	0.95048
y20	0.37059	y20	0.46860	y20	0.56027	y20	0.64340	y20	0.71694
x21	0.93301	x21	0.97553	x21	0.99635	x21	0.99915	x21	0.98746
y21	0.25000	y21	0.34549	y21	0.43973	y21	0.52907	y21	0.61126
x22	0.85355	x22	0.92216	x22	0.98751	x22	0.99240	x22	1.00000
y22	0.14645	y22	0.23209	y22	0.32270	y22	0.41318	y22	0.50000
x23	0.75000	x23	0.84227	x23	0.91149	x23	0.95911	x23	0.98746
y23	0.66699	y23	0.13552	y23	0.21597	y23	0.30196	y23	0.38874
x24	0.62941	x24	0.74088	x24	0.83156	x24	0.90106	x24	0.95048
y24	0.01704	y24	0.06185	y24	0.12574	y24	0.20142	y24	0.28306
		x25	0.62434	x25	0.73236	x25	0.82139	x25	0.89092
		y25	0.01571	y25	0.05727	y25	0.11698	y25	0.18826
		x26	0.61966	x26	0.67240	x26	0.65318	x26	0.81174
		y26	0.01453	y26	0.01453	y26	0.05318	y26	0.10908
		x27		x27	0.61531	x27	0.61531	x27	0.71694
		y27		y27	0.01348	y27	0.01348	y27	0.04952
		x28		x28		x28		x28	0.61126
		y28		y28		y28		y28	0.01254

**Table 2. Hole Coordinate Dimension Factors for Jig Boring — Type "B" Hole Circles (English or Metric Units)**

The diagram shows a type "B" circle for a 5-hole circle. Coordinates  $x$ ,  $y$  are given in the table for hole circles of from 3 to 28 holes. Dimensions are for holes numbered in a counterclockwise direction (as shown). Dimensions given are based upon a hole circle of unit diameter. For a hole circle of, say, 3-inch or 3-centimeter diameter, multiply table values by 3.

3 Holes		4 Holes		5 Holes		6 Holes		7 Holes		8 Holes		9 Holes	
$x_1$	0.06699	$x_1$	0.14645	$x_1$	0.20611	$x_1$	0.25000	$x_1$	0.28306	$x_1$	0.30866	$x_1$	0.32899
$y_1$	0.25000	$y_1$	0.14645	$y_1$	0.09549	$y_1$	0.06699	$y_1$	0.04952	$y_1$	0.03806	$y_1$	0.03015
$x_2$	0.50000	$x_2$	0.14645	$x_2$	0.02447	$x_2$	0.00000	$x_2$	0.01254	$x_2$	0.03806	$x_2$	0.06699
$y_2$	1.00000	$y_2$	0.85355	$y_2$	0.65451	$y_2$	0.50000	$y_2$	0.38874	$y_2$	0.30866	$y_2$	0.25000
$x_3$	0.93301	$x_3$	0.85355	$x_3$	0.50000	$x_3$	0.25000	$x_3$	0.10908	$x_3$	0.03806	$x_3$	0.00760
$y_3$	0.25000	$y_3$	0.85355	$y_3$	1.00000	$y_3$	0.93301	$y_3$	0.81174	$y_3$	0.69134	$y_3$	0.58682
		$x_4$	0.85355	$x_4$	0.97553	$x_4$	0.75000	$x_4$	0.50000	$x_4$	0.30866	$x_4$	0.17861
		$y_4$	0.14645	$y_4$	0.65451	$y_4$	0.93301	$y_4$	1.00000	$y_4$	0.96194	$y_4$	0.88302
				$x_5$	0.79389	$x_5$	1.00000	$x_5$	0.89092	$x_5$	0.69134	$x_5$	0.50000
				$y_5$	0.09549	$y_5$	0.50000	$y_5$	0.81174	$y_5$	0.96194	$y_5$	1.00000
						$x_6$	0.75000	$x_6$	0.98746	$x_6$	0.96194	$x_6$	0.82139
						$y_6$	0.38874	$y_6$	0.38874	$y_6$	0.69134	$y_6$	0.88302
						$x_7$	0.06699	$x_7$	0.71694	$x_7$	0.96194	$x_7$	0.99240
						$y_7$		$y_7$	0.04952	$y_7$	0.30866	$y_7$	0.58682
								$x_8$		$x_8$	0.69134	$x_8$	0.93301
								$y_8$		$y_8$	0.03806	$y_8$	0.25000
								$x_9$		$x_9$		$x_9$	0.67101
								$y_9$		$y_9$		$y_9$	0.03015
10 Holes		11 Holes		12 Holes		13 Holes		14 Holes		15 Holes		16 Holes	
$x_1$	0.34549	$x_1$	0.25913	$x_1$	0.37059	$x_1$	0.38034	$x_1$	0.38874	$x_1$	0.39604	$x_1$	0.40245
$y_1$	0.02447	$y_1$	0.02025	$y_1$	0.01704	$y_1$	0.01453	$y_1$	0.01254	$y_1$	0.01093	$y_1$	0.00961
$x_2$	0.09549	$x_2$	0.12213	$x_2$	0.14645	$x_2$	0.16844	$x_2$	0.18826	$x_2$	0.20611	$x_2$	0.22221
$y_2$	0.20611	$y_2$	0.17257	$y_2$	0.14645	$y_2$	0.12574	$y_2$	0.10908	$y_2$	0.09549	$y_2$	0.08427
$x_3$	0.00000	$x_3$	0.00509	$x_3$	0.01704	$x_3$	0.03249	$x_3$	0.04952	$x_3$	0.06699	$x_3$	0.08427
$y_3$	0.50000	$y_3$	0.42884	$y_3$	0.37059	$y_3$	0.32270	$y_3$	0.28306	$y_3$	0.25000	$y_3$	0.22221
$x_4$	0.09549	$x_4$	0.04518	$x_4$	0.01704	$x_4$	0.00365	$x_4$	0.00000	$x_4$	0.00274	$x_4$	0.00961
$y_4$	0.79389	$y_4$	0.70771	$y_4$	0.62941	$y_4$	0.56027	$y_4$	0.50000	$y_4$	0.44774	$y_4$	0.40245
$x_5$	0.34549	$x_5$	0.22968	$x_5$	0.14645	$x_5$	0.08851	$x_5$	0.04952	$x_5$	0.02447	$x_5$	0.00961
$y_5$	0.97553	$y_5$	0.92063	$y_5$	0.85355	$y_5$	0.78403	$y_5$	0.71694	$y_5$	0.65451	$y_5$	0.59755
$x_6$	0.65451	$x_6$	0.50000	$x_6$	0.37059	$x_6$	0.26764	$x_6$	0.18826	$x_6$	0.12843	$x_6$	0.08427
$y_6$	0.97553	$y_6$	1.00000	$y_6$	0.98296	$y_6$	0.94273	$y_6$	0.89092	$y_6$	0.83457	$y_6$	0.77779
$x_7$	0.90451	$x_7$	0.77032	$x_7$	0.62941	$x_7$	0.50000	$x_7$	0.38874	$x_7$	0.29663	$x_7$	0.22221
$y_7$	0.79389	$y_7$	0.92063	$y_7$	0.98296	$y_7$	1.00000	$y_7$	0.98746	$y_7$	0.95677	$y_7$	0.91573
$x_8$	1.00000	$x_8$	0.95482	$x_8$	0.85355	$x_8$	0.73236	$x_8$	0.61126	$x_8$	0.50000	$x_8$	0.40245
$y_8$	0.50000	$y_8$	0.70771	$y_8$	0.85355	$y_8$	0.94273	$y_8$	0.98746	$y_8$	1.00000	$y_8$	0.96039
$x_9$	0.90451	$x_9$	0.99491	$x_9$	0.98296	$x_9$	0.91149	$x_9$	0.81174	$x_9$	0.70337	$x_9$	0.59755
$y_9$	0.20611	$y_9$	0.42884	$y_9$	0.62941	$y_9$	0.78403	$y_9$	0.89092	$y_9$	0.95677	$y_9$	0.99039
$x_{10}$	0.65451	$x_{10}$	0.87787	$x_{10}$	0.98296	$x_{10}$	0.99635	$x_{10}$	0.95048	$x_{10}$	0.87157	$x_{10}$	0.77779
$y_{10}$	0.02447	$y_{10}$	0.17257	$y_{10}$	0.37059	$y_{10}$	0.56027	$y_{10}$	0.71694	$y_{10}$	0.83457	$y_{10}$	0.91573
		$x_{11}$	0.64687	$x_{11}$	0.85355	$x_{11}$	0.96751	$x_{11}$	1.00000	$x_{11}$	0.97553	$x_{11}$	0.91573
		$y_{11}$	0.02025	$y_{11}$	0.14645	$y_{11}$	0.32270	$y_{11}$	0.50000	$y_{11}$	0.65451	$y_{11}$	0.77779
				$x_{12}$	0.62941	$x_{12}$	0.83156	$x_{12}$	0.95048	$x_{12}$	0.99726	$x_{12}$	0.99039
				$y_{12}$	0.01704	$y_{12}$	0.12574	$y_{12}$	0.28306	$y_{12}$	0.44774	$y_{12}$	0.59755
						$x_{13}$	0.61966	$x_{13}$	0.81174	$x_{13}$	0.93301	$x_{13}$	0.99039
						$y_{13}$	0.01453	$y_{13}$	0.10908	$y_{13}$	0.25000	$y_{13}$	0.40245
								$x_{14}$	0.61126	$x_{14}$	0.79389	$x_{14}$	0.91573
								$y_{14}$	0.01254	$y_{14}$	0.09549	$y_{14}$	0.22221
										$x_{15}$	0.60396	$x_{15}$	0.77779
										$y_{15}$	0.01093	$y_{15}$	0.08427
												$x_{16}$	0.59755
												$y_{16}$	0.00961

**Table 2. (Continued) Hole Coordinate Dimension Factors for Jig Boring — Type "B" Hole Circles (English or Metric Units)**

17 Holes		18 Holes		19 Holes		20 Holes		21 Holes		22 Holes		23 Holes	
x1	0.40813	x1	0.41318	x1	0.41770	x1	0.42178	x1	0.42548	x1	0.42884	x1	0.43192
y1	0.00851	y1	0.00760	y1	0.00682	y1	0.00616	y1	0.00558	y1	0.00509	y1	0.00466
x2	0.23678	x2	0.25000	x2	0.26203	x2	0.27300	x2	0.28306	x2	0.29229	x2	0.30080
y2	0.07489	y2	0.06699	y2	0.06026	y2	0.05460	y2	0.04952	y2	0.04518	y2	0.04139
x3	0.10999	x3	0.11698	x3	0.12314	x3	0.12845	x3	0.13347	x3	0.13791	x3	0.14184
y3	0.19868	y3	0.17861	y3	0.16126	y3	0.14645	y3	0.13347	y3	0.12213	y3	0.11214
x4	0.01909	x4	0.03915	x4	0.04211	x4	0.05450	x4	0.06699	x4	0.07937	x4	0.09152
y4	0.36317	y4	0.32899	y4	0.29915	y4	0.27300	y4	0.25000	y4	0.22968	y4	0.21166
x5	0.00213	x5	0.00000	x5	0.00171	x5	0.00616	x5	0.01254	x5	0.02025	x5	0.02887
y5	0.54613	y5	0.50000	y5	0.45871	y5	0.42178	y5	0.38874	y5	0.35913	y5	0.33256
x6	0.05242	x6	0.03015	x6	0.01530	x6	0.00616	x6	0.00140	x6	0.00000	x6	0.00117
y6	0.72287	y6	0.67101	y6	0.62274	y6	0.57822	y6	0.53737	y6	0.50000	y6	0.46588
x7	0.16315	x7	0.11698	x7	0.08142	x7	0.05450	x7	0.03456	x7	0.02025	x7	0.01046
y7	0.86950	y7	0.82139	y7	0.77347	y7	0.72700	y7	0.68267	y7	0.64087	y7	0.60173
x8	0.31938	x8	0.25000	x8	0.19285	x8	0.14645	x8	0.10908	x8	0.07937	x8	0.05606
y8	0.96624	y8	0.93301	y8	0.89457	y8	0.85355	y8	0.81174	y8	0.77032	y8	0.73003
x9	0.50000	x9	0.41318	x9	0.33765	x9	0.27300	x9	0.21834	x9	0.17257	x9	0.13458
y9	1.00000	y9	0.99240	y9	0.97291	y9	0.94530	y9	0.91312	y9	0.87787	y9	0.84128
x10	0.68062	x10	0.58682	x10	0.50000	x10	0.42178	x10	0.35262	x10	0.29229	x10	0.24021
y10	0.96624	y10	0.99240	y10	1.00000	y10	0.99384	y10	0.97779	y10	0.95482	y10	0.92721
x11	0.83685	x11	0.75000	x11	0.66235	x11	0.57822	x11	0.50000	x11	0.42884	x11	0.36510
y11	0.86950	y11	0.93301	y11	0.97291	y11	0.99384	y11	1.00000	y11	0.99491	y11	0.98146
x12	0.94758	x12	0.88302	x12	0.80711	x12	0.72700	x12	0.64738	x12	0.57116	x12	0.50000
y12	0.72287	y12	0.82139	y12	0.89457	y12	0.94530	y12	0.97779	y12	0.99491	y12	1.00000
x13	0.99787	x13	0.96985	x13	0.91858	x13	0.85355	x13	0.78166	x13	0.70771	x13	0.63490
y13	0.54613	y13	0.67101	y13	0.77347	y13	0.85355	y13	0.91312	y13	0.95482	y13	0.98146
x14	0.98091	x14	1.00000	x14	0.98470	x14	0.94530	x14	0.89092	x14	0.82743	x14	0.75979
y14	0.36317	y14	0.50000	y14	0.62274	y14	0.72700	y14	0.81174	y14	0.87787	y14	0.92721
x15	0.89901	x15	0.96985	x15	0.99829	x15	0.99384	x15	0.96544	x15	0.92063	x15	0.86542
y15	0.19868	y15	0.32899	y15	0.45871	y15	0.57822	y15	0.68267	y15	0.77032	y15	0.84128
x16	0.76322	x16	0.88302	x16	0.95789	x16	0.99384	x16	0.99860	x16	0.97975	x16	0.94594
y16	0.07489	y16	0.17861	y16	0.29915	y16	0.42178	y16	0.53737	y16	0.64087	y16	0.73003
x17	0.59187	x17	0.75000	x17	0.86786	x17	0.94530	x17	0.98746	x17	1.00000	x17	0.98954
y17	0.00851	y17	0.06699	y17	0.16136	y17	0.27300	y17	0.38874	y17	0.50000	y17	0.60173
		x18	0.58682	y18	0.73797	x18	0.85355	x18	0.93301	x18	0.97975	x18	0.99883
		x18	0.00760	y18	0.16026	x18	0.14645	x18	0.25000	x18	0.35913	x18	0.46588
				y18	0.58230	x19	0.72700	x19	0.84009	x19	0.92063	x19	0.97113
					0.00682	y19	0.05450	y19	0.13347	y19	0.22968	y19	0.33256
						x20	0.57822	x20	0.71694	x20	0.82743	x20	0.90848
						y20	0.00616	y20	0.04952	y20	0.12213	y20	0.21166
								x21	0.57452	x21	0.70771	x21	0.81554
								y21	0.00558	y21	0.04518	y21	0.11214
										x22	0.57116	x22	0.69920
										y22	0.00509	y22	0.04139
												x23	0.56808
												y23	0.00466
24 Holes		25 Holes		26 Holes		27 Holes		28 Holes					
x1	0.43474	x1	0.43733	x1	0.43973	x1	0.44195	x1	0.44402				
y1	0.00428	y1	0.00394	y1	0.00365	y1	0.00338	y1	0.00314				
x2	0.30866	x2	0.31594	x2	0.32270	x2	0.32899	x2	0.33486				
y2	0.03805	y2	0.03511	y2	0.03249	y2	0.03015	y2	0.02806				
x3	0.19562	x3	0.20611	x3	0.21597	x3	0.22525	x3	0.23398				

**Table 2. (Continued) Hole Coordinate Dimension Factors for Jig Boring — Type "B" Hole Circles (English or Metric Units)**

		<p>The diagram shows a type "B" circle for a 5-hole circle. Coordinates <math>x</math>, <math>y</math> are given in the table for hole circles of from 3 to 28 holes. Dimensions are for holes numbered in a counterclockwise direction (as shown). Dimensions given are based upon a hole circle of unit diameter. For a hole circle of, say, 3-inch or 3-centimeter diameter, multiply table values by 3.</p>							
y3	0.10332	y3	0.09549	y3	0.08851	y3	0.08236	y3	0.07664
x4	0.10332	x4	0.11474	x4	0.12574	x4	0.13631	x4	0.14645
y4	0.19562	y4	0.18129	y4	0.16844	y4	0.15688	y4	0.14645
x5	0.03866	x5	0.04759	x5	0.05727	x5	0.06699	x5	0.07664
y5	0.30866	y5	0.28711	y5	0.26764	y5	0.25000	y5	0.23398
x6	0.00428	x6	0.00886	x6	0.01453	x6	0.02101	x6	0.02806
y6	0.43474	y6	0.40631	y6	0.38034	y6	0.35660	y6	0.33486
x7	0.00428	x7	0.00099	x7	0.00000	x7	0.00085	x7	0.00314
y7	0.56526	y7	0.53140	y7	0.50000	y7	0.47093	y7	0.44402
x8	0.03806	x8	0.02447	x8	0.01453	x8	0.00760	x8	0.00314
y8	0.69134	y8	0.65451	y8	0.61966	y8	0.58682	y8	0.55598
x9	0.10332	x9	0.07784	x9	0.05727	x9	0.04089	x9	0.02806
y9	0.80438	y9	0.76791	y9	0.73236	y9	0.69804	y9	0.66514
x10	0.19562	x10	0.15773	x10	0.12574	x10	0.09894	x10	0.07664
y10	0.89668	y10	0.86448	y10	0.83156	y10	0.79858	y10	0.76602
x11	0.30866	x11	0.25912	x11	0.21597	x11	0.17861	x11	0.14645
y11	0.96194	y11	0.93815	y11	0.91149	y11	0.88302	y11	0.85355
x12	0.43474	x12	0.37566	x12	0.32270	x12	0.27560	x12	0.23398
y12	0.99372	y12	0.98429	y12	0.96751	y12	0.94682	y12	0.92336
x13	0.56526	x13	0.50000	x13	0.43973	x13	0.38469	x13	0.33486
y13	0.99372	y13	1.00000	y13	0.99635	y13	0.98652	y13	0.97194
x14	0.69134	x14	0.62434	x14	0.56027	x14	0.50000	x14	0.44402
y14	0.96194	y14	0.98429	y14	0.99635	y14	1.00000	y14	0.99686
x15	0.80438	x15	0.74088	x15	0.67730	x15	0.61531	x15	0.55598
y15	0.89668	y15	0.92815	y15	0.96751	y15	0.98652	y15	0.99686
x16	0.89668	x16	0.84227	x16	0.78403	x16	0.72440	x16	0.66514
y16	0.80438	y16	0.86448	y16	0.91149	y16	0.94682	y16	0.97194
x17	0.96194	x17	0.92216	x17	0.87426	x17	0.82139	x17	0.76602
y17	0.69134	y17	0.76791	y17	0.83156	y17	0.88302	y17	0.92336
x18	0.99372	x18	0.97553	x18	0.94273	x18	0.90106	x18	0.85355
y18	0.56526	y18	0.65451	y18	0.73236	y18	0.79838	y18	0.85355
x19	0.99372	x19	0.99901	x19	0.98547	x19	0.95911	x19	0.92336
y19	0.43474	y19	0.53140	y19	0.61966	y19	0.69804	y19	0.76602
x20	0.96194	x20	0.99114	x20	1.00000	x20	0.99240	x20	0.97194
y20	0.30866	y20	0.40631	y20	0.50000	y20	0.58682	y20	0.66514
x21	0.89668	x21	0.95241	x21	0.98547	x21	0.99915	x21	0.99686
y21	0.19562	y21	0.28711	y21	0.38034	y21	0.47093	y21	0.55598
x22	0.80438	x22	0.88526	x22	0.94273	x22	0.97899	x22	0.99686
y22	0.10332	y22	0.18129	y22	0.26764	y22	0.35660	y22	0.44402
x23	0.69134	x23	0.79389	x23	0.87426	x23	0.93301	x23	0.97194
y23	0.03806	y23	0.09549	y23	0.16844	y23	0.25000	y23	0.33486
x24	0.56526	x24	0.68406	x24	0.78403	x24	0.86369	x24	0.92336
y24	0.00428	y24	0.03511	y24	0.08851	y24	0.16688	y24	0.23398
		x25	0.56267	x25	0.67730	x25	0.77475	x25	0.85355
		y25	0.00394	y25	0.03249	y25	0.08226	y25	0.14645
				x26	0.56027	x26	0.67101	x26	0.76602
				y26	0.00365	y26	0.03015	y26	0.07664
						x27	0.55805	x27	0.66514
						y27	0.00338	y27	0.02806
								x28	0.55598
								y28	0.00314

**Table 3. Hole Coordinate Dimension Factors for Jig Boring — Type "A" Hole Circles, Central Coordinates (English or Metric Units)**

The diagram shows a type "A" circle for a 5-hole circle. Coordinates x, y are given in the table for hole circles of from 3 to 28 holes. Dimensions are for holes numbered in a counterclockwise direction (as shown). Dimensions given are based upon a hole circle of unit diameter. For a hole circle of, say, 3-inch or 3-centimeter diameter, multiply table values by 3.

3 Holes		4 Holes		5 Holes		6 Holes		7 Holes		8 Holes		9 Holes	
x1	0.00000	x1	0.00000	x1	0.00000	x1	0.00000	x1	0.00000	x1	0.00000	x1	0.00000
y1	-0.50000	y1	-0.50000	y1	-0.50000	y1	-0.50000	y1	-0.50000	y1	-0.50000	y1	-0.50000
x2	-0.43301	x2	-0.50000	x2	-0.47553	x2	-0.43301	x2	-0.39092	x2	-0.35355	x2	-0.32139
y2	+0.25000	y2	0.00000	y2	-0.15451	y2	-0.25000	y2	-0.31174	y2	-0.35355	y2	-0.38302
x3	+0.43301	x3	0.00000	x3	-0.29389	x3	-0.43301	x3	-0.48746	x3	-0.50000	x3	-0.49240
y3	+0.25000	y3	+0.50000	y3	+0.40451	y3	+0.25000	y3	+0.11126	y3	0.00000	y3	-0.08682
		x4	+0.50000	x4	+0.29389	x4	0.00000	x4	-0.21694	x4	-0.35355	x4	-0.43301
		y4	0.00000	y4	+0.40451	y4	+0.50000	y4	+0.45048	y4	+0.35355	y4	+0.25000
				x5	-0.47553	x5	-0.43301	x5	+0.21694	x5	0.00000	x5	-0.17101
				y5	-0.15451	y5	+0.25000	y5	+0.45048	y5	+0.50000	y5	-0.46985
						x6	+0.43301	x6	+0.48746	x6	+0.35355	x6	+0.17101
						y6	-0.25000	y6	+0.11126	y6	+0.35355	y6	-0.46985
						x7		x7	+0.39092	x7	+0.50000	x7	-0.43301
						y7		y7	-0.31174	y7	0.00000	y7	+0.25000
								x8	+0.35355	x8	+0.49240	x8	+0.49240
								y8	-0.35355	y8	-0.08682	y8	-0.08682
										x9	+0.32139	x9	+0.32139
										y9	-0.38302	y9	-0.38302
10 Holes		11 Holes		12 Holes		13 Holes		14 Holes		15 Holes		16 Holes	
x1	0.00000	x1	0.00000	x1	0.00000	x1	0.00000	x1	0.00000	x1	0.00000	x1	0.00000
y1	-0.50000	y1	-0.50000	y1	-0.50000	y1	-0.50000	y1	-0.50000	y1	-0.50000	y1	-0.50000
x2	-0.29389	x2	-0.27032	x2	-0.25000	x2	-0.23226	x2	-0.21694	x2	-0.20337	x2	-0.19134
y2	-0.40451	y2	-0.42063	y2	-0.43301	y2	-0.44273	y2	-0.45048	y2	-0.45677	y2	-0.46194
x3	-0.47553	x3	-0.45482	x3	-0.43301	x3	-0.41149	x3	-0.39092	x3	-0.37157	x3	-0.35355
y3	-0.15451	y3	-0.20771	y3	-0.25000	y3	-0.28403	y3	-0.31174	y3	-0.33457	y3	-0.35355
x4	-0.47553	x4	-0.49981	x4	-0.50000	x4	-0.49635	x4	-0.48746	x4	-0.47553	x4	-0.46194
y4	+0.15451	y4	+0.07116	y4	0.00000	y4	-0.06027	y4	-0.11126	y4	-0.15451	y4	-0.19134
x5	-0.29389	x5	-0.37787	x5	-0.43301	x5	-0.46751	x5	-0.48746	x5	-0.49726	x5	-0.50000
y5	+0.40451	y5	+0.32743	y5	+0.25000	y5	+0.17730	y5	+0.11126	y5	+0.05226	y5	0.00000
x6	0.00000	x6	-0.14087	x6	-0.25000	x6	-0.33156	x6	-0.39092	x6	-0.43301	x6	-0.46194
y6	+0.50000	y6	+0.47975	y6	+0.43301	y6	+0.37426	y6	+0.31174	y6	+0.25000	y6	+0.19134
x7	+0.29389	x7	+0.14087	x7	0.00000	x7	-0.11966	x7	-0.21694	x7	-0.29389	x7	-0.35355
y7	+0.40451	y7	+0.47975	y7	+0.50000	y7	+0.48547	y7	+0.45048	y7	+0.40451	y7	+0.35355
x8	+0.47553	x8	+0.37787	x8	+0.25000	x8	+0.11966	x8	0.00000	x8	-0.10396	x8	-0.19134
y8	+0.15451	y8	+0.32743	y8	+0.43301	y8	+0.48547	y8	+0.50000	y8	+0.48907	y8	+0.46194
x9	-0.47553	x9	-0.49491	x9	-0.43301	x9	-0.33156	x9	-0.21694	x9	+0.10396	x9	0.00000
y9	-0.15451	y9	+0.07116	y9	+0.25000	y9	+0.37426	y9	+0.45048	y9	+0.48907	y9	+0.50000
x10	+0.29389	x10	+0.45482	x10	+0.50000	x10	+0.46751	x10	+0.39092	x10	+0.29389	x10	+0.19134
y10	-0.40451	y10	-0.20771	y10	0.00000	y10	-0.17730	y10	+0.31174	y10	+0.40451	y10	+0.46194
		x11	-0.27032	x11	-0.43301	x11	-0.48635	x11	-0.48746	x11	-0.43301	x11	-0.35355
		y11	-0.42063	y11	-0.25000	y11	-0.06027	y11	+0.11126	y11	+0.25000	y11	+0.35355
				x12	+0.25000	x12	+0.41149	x12	+0.48746	x12	+0.49726	x12	+0.46194
				y12	-0.43301	y12	-0.28403	y12	-0.11126	y12	+0.05226	y12	+0.19134
						x13	-0.23226	x13	-0.39092	x13	+0.47553	x13	+0.50000
						y13	-0.44273	y13	-0.31174	y13	-0.15451	y13	0.00000
								x14	+0.21694	x14	+0.37157	x14	+0.46194
								y14	-0.45048	y14	-0.33457	y14	-0.19134
										x15	+0.20337	x15	+0.35355
										y15	-0.45677	y15	-0.35355
												x16	+0.19134
												y16	-0.46194





Table 3. (Continued) Hole Coordinate Dimension Factors for Jig Boring — Type "A" Hole Circles, Central Coordinates (English or Metric Units)

					The diagram shows a type "A" circle for a 5-hole circle. Coordinates x, y are given in the table for hole circles of from 3 to 28 holes. Dimensions are for holes numbered in a counterclockwise direction (as shown). Dimensions given are based upon a hole circle of unit diameter. For a hole circle of, say, 3-inch or 3-centimeter diameter, multiply table values by 3.				
y3	-0.43301	y3	-0.43815	y3	-0.44273	y3	-0.44682	y3	-0.45048
x4	-0.35355	x4	-0.34227	x4	-0.33156	x4	-0.32139	x4	-0.31174
y4	-0.35355	y4	-0.36448	y4	-0.37426	y4	-0.38302	y4	-0.39092
x5	-0.43301	x5	-0.42216	x5	-0.41149	x5	-0.40106	x5	-0.39092
y5	-0.25000	y5	-0.26791	y5	-0.28403	y5	-0.29858	y5	-0.31174
x6	-0.48296	x6	-0.47553	x6	-0.46751	x6	-0.45911	x6	-0.45048
y6	-0.12941	y6	-0.15451	y6	-0.17730	y6	-0.19804	y6	-0.21694
x7	-0.50000	x7	-0.49901	x7	-0.49635	x7	-0.49240	x7	-0.48746
y7	0.00000	y7	-0.03140	y7	-0.06027	y7	-0.08682	y7	-0.11126
x8	-0.48296	x8	-0.49114	x8	-0.49635	x8	-0.49915	x8	-0.50000
y8	+0.12941	y8	+0.09369	y8	+0.06027	y8	+0.02907	y8	0.00000
x9	-0.43301	x9	-0.45241	x9	-0.46751	x9	-0.47899	x9	-0.48746
y9	+0.25000	y9	+0.21289	y9	+0.17730	y9	+0.14540	y9	+0.11126
x10	-0.35355	x10	-0.38526	x10	-0.41149	x10	-0.43301	x10	-0.45048
y10	+0.35355	y10	+0.31871	y10	+0.28403	y10	+0.25000	y10	+0.21694
x11	-0.25000	x11	-0.29389	x11	-0.33156	x11	-0.36369	x11	-0.39092
y11	+0.43301	y11	+0.40451	y11	+0.37426	y11	+0.34312	y11	+0.31174
x12	-0.12941	x12	-0.18406	x12	-0.23236	x12	-0.27475	x12	-0.31174
y12	+0.48296	y12	+0.46489	y12	+0.44273	y12	+0.41774	y12	+0.39092
x13	0.00000	x13	-0.06267	x13	-0.11966	x13	-0.17101	x13	-0.21694
y13	+0.50000	y13	+0.49606	y13	+0.48547	y13	+0.46985	y13	+0.45048
x14	+0.12941	x14	+0.06267	x14	0.00000	x14	-0.05805	x14	-0.11126
y14	-0.48296	y14	-0.49606	y14	-0.50000	y14	-0.49662	y14	-0.48746
x15	+0.25000	x15	+0.18406	x15	+0.11966	x15	+0.05805	x15	0.00000
y15	-0.43301	y15	-0.46489	y15	-0.48547	y15	-0.49662	y15	-0.50000
x16	+0.35355	x16	+0.29389	x16	-0.23236	x16	+0.17101	x16	+0.11126
y16	-0.35355	y16	-0.40451	y16	-0.44273	y16	-0.46985	y16	-0.48746
x17	+0.43301	x17	+0.38526	x17	+0.33156	x17	+0.27475	x17	+0.21694
y17	+0.25000	y17	+0.31871	y17	+0.37426	y17	+0.41774	y17	+0.45048
x18	+0.48296	x18	+0.45241	x18	+0.41149	x18	+0.36369	x18	+0.31174
y18	+0.12941	y18	+0.21289	y18	+0.28403	y18	+0.34312	y18	+0.39092
x19	0.00000	x19	+0.49114	x19	+0.46751	x19	+0.43301	x19	+0.39092
y19	+0.50000	y19	+0.09369	y19	+0.17730	y19	+0.25000	y19	+0.31174
x20	+0.48296	x20	+0.49901	x20	+0.49635	x20	+0.47899	x20	+0.45048
y20	-0.12941	y20	-0.03140	y20	-0.06027	y20	-0.14340	y20	-0.21694
x21	+0.43301	x21	+0.47553	x21	+0.49635	x21	+0.49915	x21	+0.48746
y21	-0.25000	y21	-0.15451	y21	-0.06027	y21	+0.02907	y21	+0.11126
x22	+0.35355	x22	+0.42216	x22	+0.46751	x22	+0.49240	x22	+0.50000
y22	-0.35355	y22	-0.26791	y22	-0.17730	y22	-0.08682	y22	0.00000
x23	+0.25000	x23	+0.34227	x23	+0.41149	x23	+0.45911	x23	+0.48746
y23	-0.43301	y23	-0.36448	y23	-0.28403	y23	-0.19804	y23	-0.11126
x24	+0.12941	x24	+0.24088	x24	-0.33156	x24	-0.40106	x24	+0.45048
y24	-0.48296	y24	-0.43815	y24	-0.37426	y24	-0.29858	y24	-0.21694
		x25	+0.12434	x25	+0.23236	x25	+0.32139	x25	+0.39092
		y25	-0.48429	y25	-0.44273	y25	-0.38302	y25	-0.31174
		x26	+0.11966	x26	+0.11966	x26	+0.22440	x26	+0.31174
		y26	-0.48547	y26	-0.44682	y26	-0.44682	y26	-0.39092
				x27	+0.11531	x27	+0.11531	x27	+0.21694
				y27	-0.48652	y27	-0.48652	y27	-0.45048
				x28		x28		x28	+0.11126
				y28		y28		y28	-0.48746

**Table 4. Hole Coordinate Dimension Factors for Jig Boring —Type “B”  
Hole Circles Central Coordinates (English or Metric units)**

The diagram shows a type “B” circle for a 5-hole circle. Coordinates x, y are given in the table for hole circles of from 3 to 28 holes. Dimensions are for holes numbered in a counterclockwise direction (as shown). Dimensions given are based upon a hole circle of unit diameter. For a hole circle of, say, 3-inch or 3-centimeter diameter, multiply table values by 3.

3 Holes		4 Holes		5 Holes		6 Holes		7 Holes		8 Holes		9 Holes	
x1	-0.43301	x1	-0.35355	x1	-0.29389	x1	-0.25000	x1	-0.21694	x1	-0.19134	x1	-0.17101
y1	-0.25000	y1	-0.35355	y1	-0.40451	y1	-0.43301	y1	-0.45048	y1	-0.46194	y1	-0.46985
x2	0.00000	x2	-0.35355	x2	-0.47553	x2	-0.50000	x2	-0.48746	x2	-0.46194	x2	-0.43301
y2	+0.50000	y2	+0.35355	y2	+0.15451	y2	0.00000	y2	-0.11126	y2	-0.19134	y2	-0.25000
x3	+0.43301	x3	+0.35355	x3	0.00000	x3	-0.25000	x3	-0.39092	x3	-0.46194	x3	-0.49240
y3	-0.25000	y3	+0.35355	y3	+0.50000	y3	+0.43301	y3	+0.31174	y3	+0.19134	y3	+0.08682
		y4	-0.35355	y4	+0.47553	y4	+0.25000	y4	0.00000	y4	-0.19134	y4	-0.32139
				y4	+0.15451	y4	+0.43301	y4	+0.50000	y4	+0.46194	y4	+0.38302
				y5	-0.29389	y5	+0.50000	y5	+0.39092	y5	+0.19134	y5	0.00000
				y5	-0.40451	y5	0.00000	y5	+0.31174	y5	+0.46194	y5	+0.50000
								y6	+0.48746	y6	+0.46194	y6	+0.32139
								y6	-0.11126	y6	+0.19134	y6	+0.38302
								y7	-0.21694	y7	+0.46194	y7	+0.49240
								y7	-0.45048	y7	-0.19134	y7	+0.08682
										y8	+0.19134	y8	+0.43301
										y8	-0.46194	y8	-0.25000
										y9		y9	+0.17101
										y9		y9	-0.46985
10 Holes		11 Holes		12 Holes		13 Holes		14 Holes		15 Holes		16 Holes	
x1	-0.15451	x1	-0.14087	x1	-0.12941	x1	-0.11966	x1	-0.11126	x1	-0.10396	x1	-0.09755
y1	-0.47553	y1	-0.47975	y1	-0.48296	y1	-0.48547	y1	-0.48746	y1	-0.48907	y1	-0.49039
x2	-0.40451	x2	-0.37787	x2	-0.35355	x2	-0.33156	x2	-0.31174	x2	-0.29389	x2	-0.27779
y2	-0.28389	y2	-0.32743	y2	-0.35355	y2	-0.37426	y2	-0.39092	y2	-0.40451	y2	-0.41573
x3	-0.50000	x3	-0.49491	x3	-0.48296	x3	-0.46751	x3	-0.45048	x3	-0.43301	x3	-0.41573
y3	0.00000	y3	-0.07116	y3	-0.12941	y3	-0.17730	y3	-0.21694	y3	-0.25000	y3	-0.27779
x4	-0.40451	x4	-0.45482	x4	-0.48296	x4	-0.49635	x4	-0.50000	x4	-0.49726	x4	-0.49039
y4	+0.29389	y4	+0.20771	y4	+0.12941	y4	+0.06027	y4	0.00000	y4	-0.05226	y4	-0.09755
x5	-0.15451	x5	-0.27032	x5	-0.35355	x5	-0.41149	x5	-0.45048	x5	-0.47553	x5	-0.49039
y5	+0.47553	y5	+0.42063	y5	+0.35355	y5	+0.28403	y5	+0.21694	y5	+0.15451	y5	+0.09755
x6	+0.15451	x6	0.00000	x6	-0.12941	x6	-0.23236	x6	-0.31174	x6	-0.37157	x6	-0.41573
y6	+0.47553	y6	+0.50000	y6	+0.48296	y6	+0.44273	y6	+0.39092	y6	+0.33457	y6	+0.27779
x7	+0.40451	x7	+0.27032	x7	-0.12941	x7	0.00000	x7	-0.11126	x7	-0.20337	x7	-0.27779
y7	-0.28389	y7	+0.42063	y7	-0.48296	y7	+0.50000	y7	+0.48746	y7	+0.45677	y7	+0.41573
x8	-0.50000	x8	+0.45482	x8	-0.35355	x8	+0.23236	x8	+0.11126	x8	0.00000	x8	-0.09755
y8	0.00000	y8	+0.20771	y8	+0.35355	y8	+0.44273	y8	+0.48746	y8	+0.50000	y8	+0.49039
x9	-0.40451	x9	+0.49491	x9	+0.48296	x9	+0.41149	x9	+0.31174	x9	+0.20337	x9	-0.09755
y9	-0.29389	y9	-0.07116	y9	-0.12941	y9	+0.28403	y9	+0.39092	y9	+0.43677	y9	+0.49039
x10	-0.15451	x10	-0.37787	x10	-0.48296	x10	-0.49635	x10	-0.45048	x10	-0.27157	x10	-0.27779
y10	-0.47553	y10	-0.32743	y10	-0.12941	y10	-0.06027	y10	-0.21694	y10	+0.33457	y10	+0.41573
		x11	-0.14087	x11	-0.35355	x11	-0.46751	x11	-0.50000	x11	+0.47553	x11	+0.41573
		y11	-0.47975	y11	-0.35355	y11	-0.17730	y11	0.00000	y11	+0.15451	y11	+0.27779
				x12	+0.12941	x12	+0.33156	x12	-0.45048	x12	+0.49726	x12	+0.49039
				y12	-0.48296	y12	-0.37426	y12	-0.21694	y12	-0.05226	y12	+0.09755
						x13	-0.11966	x13	-0.31174	x13	+0.43301	x13	+0.49039
						y13	-0.48547	y13	-0.39092	y13	-0.25000	y13	-0.09755
								x14	+0.11126	x14	+0.29389	x14	+0.41573
								y14	-0.48746	y14	-0.40451	y14	-0.27779
										x15	+0.10396	x15	+0.27779
										y15	-0.48907	y15	-0.41573
										x16	-0.09755	x16	-0.09755
										y16	-0.49039	y16	-0.49039

Table 4. (Continued) Hole Coordinate Dimension Factors for Jig Boring —Type "B"  
Hole Circles Central Coordinates (English or Metric units)

17 Holes		18 Holes		19 Holes		20 Holes		21 Holes		22 Holes		23 Holes	
x1 -0.09187	x1 -0.08682	x1 -0.08230	x1 -0.07822	x1 -0.07452	x1 -0.07116	x1 -0.06808	y1 -0.49149	y1 -0.49240	y1 -0.49384	y1 -0.49442	y1 -0.49491	y1 -0.49534	y1 -0.49581
y1 -0.49149	y1 -0.49240	y1 -0.49384	y1 -0.49442	y1 -0.49491	y1 -0.49534	y1 -0.49581	x2 -0.26322	x2 -0.25900	x2 -0.23797	x2 -0.21694	x2 -0.20771	x2 -0.19920	x2 -0.19120
x2 -0.26322	x2 -0.25900	x2 -0.23797	x2 -0.21694	x2 -0.20771	x2 -0.19920	x2 -0.19120	y2 -0.42511	y2 -0.43301	y2 -0.43974	y2 -0.44550	y2 -0.45048	y2 -0.45482	y2 -0.45861
y2 -0.42511	y2 -0.43301	y2 -0.43974	y2 -0.44550	y2 -0.45048	y2 -0.45482	y2 -0.45861	x3 -0.39901	x3 -0.38302	x3 -0.36786	x3 -0.35355	x3 -0.34009	x3 -0.32743	x3 -0.31554
x3 -0.39901	x3 -0.38302	x3 -0.36786	x3 -0.35355	x3 -0.34009	x3 -0.32743	x3 -0.31554	y3 -0.30132	y3 -0.32139	y3 -0.33864	y3 -0.35355	y3 -0.36653	y3 -0.37787	y3 -0.38786
y3 -0.30132	y3 -0.32139	y3 -0.33864	y3 -0.35355	y3 -0.36653	y3 -0.37787	y3 -0.38786	x4 -0.48091	x4 -0.46985	x4 -0.45789	x4 -0.44550	x4 -0.43301	x4 -0.42063	x4 -0.40848
x4 -0.48091	x4 -0.46985	x4 -0.45789	x4 -0.44550	x4 -0.43301	x4 -0.42063	x4 -0.40848	y4 -0.13683	y4 -0.17101	y4 -0.20085	y4 -0.22700	y4 -0.25000	y4 -0.27032	y4 -0.28834
y4 -0.13683	y4 -0.17101	y4 -0.20085	y4 -0.22700	y4 -0.25000	y4 -0.27032	y4 -0.28834	x5 -0.49787	x5 -0.50000	x5 -0.49829	x5 -0.49384	x5 -0.48746	x5 -0.47975	x5 -0.47113
x5 -0.49787	x5 -0.50000	x5 -0.49829	x5 -0.49384	x5 -0.48746	x5 -0.47975	x5 -0.47113	y5 -0.04613	y5 -0.00000	y5 -0.04129	y5 -0.07822	y5 -0.11126	y5 -0.14087	y5 -0.16744
y5 -0.04613	y5 -0.00000	y5 -0.04129	y5 -0.07822	y5 -0.11126	y5 -0.14087	y5 -0.16744	x6 -0.44758	x6 -0.46985	x6 -0.48470	x6 -0.49384	x6 -0.49860	x6 -0.50000	x6 -0.49883
x6 -0.44758	x6 -0.46985	x6 -0.48470	x6 -0.49384	x6 -0.49860	x6 -0.50000	x6 -0.49883	y6 -0.22287	y6 -0.17101	y6 -0.12274	y6 -0.07822	y6 -0.03737	y6 -0.00000	y6 -0.03412
y6 -0.22287	y6 -0.17101	y6 -0.12274	y6 -0.07822	y6 -0.03737	y6 -0.00000	y6 -0.03412	x7 -0.33685	x7 -0.28202	x7 -0.23747	x7 -0.19450	x7 -0.15354	x7 -0.11408	x7 -0.07613
x7 -0.33685	x7 -0.28202	x7 -0.23747	x7 -0.19450	x7 -0.15354	x7 -0.11408	x7 -0.07613	y7 -0.36950	y7 -0.32139	y7 -0.27347	y7 -0.22700	y7 -0.18265	y7 -0.14087	y7 -0.10173
y7 -0.36950	y7 -0.32139	y7 -0.27347	y7 -0.22700	y7 -0.18265	y7 -0.14087	y7 -0.10173	x8 -0.18062	x8 -0.25000	x8 -0.30711	x8 -0.35355	x8 -0.39092	x8 -0.42063	x8 -0.44394
x8 -0.18062	x8 -0.25000	x8 -0.30711	x8 -0.35355	x8 -0.39092	x8 -0.42063	x8 -0.44394	y8 -0.46624	y8 -0.43301	y8 -0.39457	y8 -0.35355	y8 -0.31174	y8 -0.27032	y8 -0.23003
y8 -0.46624	y8 -0.43301	y8 -0.39457	y8 -0.35355	y8 -0.31174	y8 -0.27032	y8 -0.23003	x9 -0.00000	x9 -0.08682	x9 -0.16235	x9 -0.22700	x9 -0.28166	x9 -0.32743	x9 -0.36542
x9 -0.00000	x9 -0.08682	x9 -0.16235	x9 -0.22700	x9 -0.28166	x9 -0.32743	x9 -0.36542	y9 -0.50000	y9 -0.49240	y9 -0.47291	y9 -0.44550	y9 -0.41312	y9 -0.37787	y9 -0.34128
y9 -0.50000	y9 -0.49240	y9 -0.47291	y9 -0.44550	y9 -0.41312	y9 -0.37787	y9 -0.34128	x10 -0.18062	x10 -0.18682	x10 -0.18000	x10 -0.07822	x10 -0.14738	x10 -0.20771	x10 -0.25979
x10 -0.18062	x10 -0.18682	x10 -0.18000	x10 -0.07822	x10 -0.14738	x10 -0.20771	x10 -0.25979	y10 -0.46624	y10 -0.49240	y10 -0.50000	y10 -0.49384	y10 -0.47779	y10 -0.45482	y10 -0.42721
y10 -0.46624	y10 -0.49240	y10 -0.50000	y10 -0.49384	y10 -0.47779	y10 -0.45482	y10 -0.42721	x11 -0.33685	x11 -0.25000	x11 -0.16235	x11 -0.07822	x11 -0.00000	x11 -0.07116	x11 -0.13490
x11 -0.33685	x11 -0.25000	x11 -0.16235	x11 -0.07822	x11 -0.00000	x11 -0.07116	x11 -0.13490	y11 -0.36950	y11 -0.43301	y11 -0.47291	y11 -0.49384	y11 -0.50000	y11 -0.49491	y11 -0.48146
y11 -0.36950	y11 -0.43301	y11 -0.47291	y11 -0.49384	y11 -0.50000	y11 -0.49491	y11 -0.48146	x12 -0.44758	x12 -0.38302	x12 -0.30711	x12 -0.22700	x12 -0.14738	x12 -0.07116	x12 -0.00000
x12 -0.44758	x12 -0.38302	x12 -0.30711	x12 -0.22700	x12 -0.14738	x12 -0.07116	x12 -0.00000	y12 -0.22287	y12 -0.32139	y12 -0.39457	y12 -0.44550	y12 -0.47779	y12 -0.49491	y12 -0.50000
y12 -0.22287	y12 -0.32139	y12 -0.39457	y12 -0.44550	y12 -0.47779	y12 -0.49491	y12 -0.50000	x13 -0.49787	x13 -0.46985	x13 -0.41858	x13 -0.35355	x13 -0.28166	x13 -0.20771	x13 -0.13490
x13 -0.49787	x13 -0.46985	x13 -0.41858	x13 -0.35355	x13 -0.28166	x13 -0.20771	x13 -0.13490	y13 -0.04613	y13 -0.17101	y13 -0.27347	y13 -0.35355	y13 -0.41312	y13 -0.45482	y13 -0.48146
y13 -0.04613	y13 -0.17101	y13 -0.27347	y13 -0.35355	y13 -0.41312	y13 -0.45482	y13 -0.48146	x14 -0.48091	x14 -0.50000	x14 -0.48470	x14 -0.44550	x14 -0.39092	x14 -0.32743	x14 -0.25979
x14 -0.48091	x14 -0.50000	x14 -0.48470	x14 -0.44550	x14 -0.39092	x14 -0.32743	x14 -0.25979	y14 -0.13683	y14 -0.00000	y14 -0.12274	y14 -0.22700	y14 -0.31174	y14 -0.37787	y14 -0.42721
y14 -0.13683	y14 -0.00000	y14 -0.12274	y14 -0.22700	y14 -0.31174	y14 -0.37787	y14 -0.42721	x15 -0.39901	x15 -0.46985	x15 -0.49829	x15 -0.49384	x15 -0.46544	x15 -0.42063	x15 -0.36542
x15 -0.39901	x15 -0.46985	x15 -0.49829	x15 -0.49384	x15 -0.46544	x15 -0.42063	x15 -0.36542	y15 -0.30132	y15 -0.17101	y15 -0.04129	y15 -0.07822	y15 -0.15354	y15 -0.23003	y15 -0.30428
y15 -0.30132	y15 -0.17101	y15 -0.04129	y15 -0.07822	y15 -0.15354	y15 -0.23003	y15 -0.30428	x16 -0.26322	x16 -0.38302	x16 -0.45789	x16 -0.49384	x16 -0.49860	x16 -0.47975	x16 -0.44394
x16 -0.26322	x16 -0.38302	x16 -0.45789	x16 -0.49384	x16 -0.49860	x16 -0.47975	x16 -0.44394	y16 -0.42511	y16 -0.32139	y16 -0.20085	y16 -0.07822	y16 -0.03737	y16 -0.00000	y16 -0.48954
y16 -0.42511	y16 -0.32139	y16 -0.20085	y16 -0.07822	y16 -0.03737	y16 -0.00000	y16 -0.48954	x17 -0.09187	x17 -0.25000	x17 -0.36786	x17 -0.44550	x17 -0.48746	x17 -0.50000	x17 -0.48954
x17 -0.09187	x17 -0.25000	x17 -0.36786	x17 -0.44550	x17 -0.48746	x17 -0.50000	x17 -0.48954	y17 -0.49149	y17 -0.43301	y17 -0.33864	y17 -0.22700	y17 -0.11126	y17 -0.00000	y17 -0.10173
y17 -0.49149	y17 -0.43301	y17 -0.33864	y17 -0.22700	y17 -0.11126	y17 -0.00000	y17 -0.10173	x18 -0.48091	x18 -0.48682	x18 -0.43974	x18 -0.35355	x18 -0.43301	x18 -0.47975	x18 -0.49883
x18 -0.48091	x18 -0.48682	x18 -0.43974	x18 -0.35355	x18 -0.43301	x18 -0.47975	x18 -0.49883	y18 -0.13683	y18 -0.08682	y18 -0.03974	y18 -0.25000	y18 -0.14087	y18 -0.03412	y18 -0.03412
y18 -0.13683	y18 -0.08682	y18 -0.03974	y18 -0.25000	y18 -0.14087	y18 -0.03412	y18 -0.03412	x19 -0.39901	x19 -0.08230	x19 -0.49318	x19 -0.44550	x19 -0.34009	x19 -0.42063	x19 -0.47113
x19 -0.39901	x19 -0.08230	x19 -0.49318	x19 -0.44550	x19 -0.34009	x19 -0.42063	x19 -0.47113	y19 -0.30132	y19 -0.25000	y19 -0.21694	y19 -0.18265	y19 -0.14087	y19 -0.10173	y19 -0.06744
y19 -0.30132	y19 -0.25000	y19 -0.21694	y19 -0.18265	y19 -0.14087	y19 -0.10173	y19 -0.06744	x20 -0.44758	x20 -0.45048	x20 -0.45048	x20 -0.45048	x20 -0.45048	x20 -0.45048	x20 -0.45048
x20 -0.44758	x20 -0.45048	x20 -0.45048	x20 -0.45048	x20 -0.45048	x20 -0.45048	x20 -0.45048	y20 -0.22287	y20 -0.17101	y20 -0.12274	y20 -0.07822	y20 -0.03737	y20 -0.00000	y20 -0.03412
y20 -0.22287	y20 -0.17101	y20 -0.12274	y20 -0.07822	y20 -0.03737	y20 -0.00000	y20 -0.03412	x21 -0.33685	x21 -0.28202	x21 -0.23747	x21 -0.19450	x21 -0.15354	x21 -0.11408	x21 -0.07613
x21 -0.33685	x21 -0.28202	x21 -0.23747	x21 -0.19450	x21 -0.15354	x21 -0.11408	x21 -0.07613	y21 -0.36950	y21 -0.32139	y21 -0.27347	y21 -0.22700	y21 -0.18265	y21 -0.14087	y21 -0.10173
y21 -0.36950	y21 -0.32139	y21 -0.27347	y21 -0.22700	y21 -0.18265	y21 -0.14087	y21 -0.10173	x22 -0.18062	x22 -0.25000	x22 -0.30711	x22 -0.35355	x22 -0.39092	x22 -0.42063	x22 -0.44394
x22 -0.18062	x22 -0.25000	x22 -0.30711	x22 -0.35355	x22 -0.39092	x22 -0.42063	x22 -0.44394	y22 -0.46624	y22 -0.43301	y22 -0.39457	y22 -0.35355	y22 -0.31174	y22 -0.27032	y22 -0.23003
y22 -0.46624	y22 -0.43301	y22 -0.39457	y22 -0.35355	y22 -0.31174	y22 -0.27032	y22 -0.23003	x23 -0.00000	x23 -0.08682	x23 -0.16235	x23 -0.22700	x23 -0.28166	x23 -0.32743	x23 -0.36542
x23 -0.00000	x23 -0.08682	x23 -0.16235	x23 -0.22700	x23 -0.28166	x23 -0.32743	x23 -0.36542	y23 -0.50000	y23 -0.49240	y23 -0.47291	y23 -0.44550	y23 -0.41312	y23 -0.37787	y23 -0.34128
y23 -0.50000	y23 -0.49240	y23 -0.47291	y23 -0.44550	y23 -0.41312	y23 -0.37787	y23 -0.34128	x24 -0.18062	x24 -0.18682	x24 -0.18000	x24 -0.07822	x24 -0.14738	x24 -0.20771	x24 -0.25979
x24 -0.18062	x24 -0.18682	x24 -0.18000	x24 -0.07822	x24 -0.14738	x24 -0.20771	x24 -0.25979	y24 -0.46624	y24 -0.49240	y24 -0.50000	y24 -0.49384	y24 -0.47779	y24 -0.45482	y24 -0.42721
y24 -0.46624	y24 -0.49240	y24 -0.50000	y24 -0.49384	y24 -0.47779	y24 -0.45482	y24 -0.42721	x25 -0.33685	x25 -0.25000	x25 -0.16235	x25 -0.07822	x25 -0.00000	x25 -0.07116	x25 -0.13490
x25 -0.33685	x25 -0.25000	x25 -0.16235	x25 -0.07822	x25 -0.00000	x25 -0.07116	x25 -0.13490	y25 -0.36950	y25 -0.43301	y25 -0.47291	y25 -0.49384	y25 -0.50000	y25 -0.49491	y25 -0.48146
y25 -0.36950	y25 -0.43301	y25 -0.47291	y25 -0.49384	y25 -0.50000	y25 -0.49491	y25 -0.48146	x26 -0.44758	x26 -0.38302	x26 -0.30711	x26 -0.22700	x26 -0.14738	x26 -0.07116	x26 -0.00000
x26 -0.44758	x26 -0.38302	x26 -0.30711	x26 -0.22700	x26 -0.14738	x26 -0.07116	x26 -0.00000	y26 -0.22287	y26 -0.32139	y26 -0.39457	y26 -0.44550	y26 -0.47779	y26 -0.49491	y26 -0.50000
y26 -0.22287	y26 -0.32139	y26 -0.39457	y26 -0.44550	y26 -0.47779	y26 -0.49491	y26 -0.50000	x27 -0.49787	x27 -0.46985	x27 -0.41858	x27 -0.35355	x27 -0.28166	x27 -0.20771	x27 -0.13490
x27 -0.49787	x27 -0.46985	x27 -0.41858	x27 -0.35355	x27 -0.28166	x27 -0.20771	x27 -0.13490	y27 -0.04613	y27 -0.17101	y27 -0.27347	y27 -0.35355	y27 -0.41312	y27 -0.45482	y27 -0.48146
y27 -0.04613	y27 -0.17101	y27 -0.27347	y27 -0.35355	y27 -0.41312	y								

**Table 4. (Continued) Hole Coordinate Dimension Factors for Jig Boring —Type “B”  
Hole Circles Central Coordinates (English or Metric units)**

The diagram shows a type “B” circle for a 5-hole circle. Coordinates $x$ , $y$ are given in the table for hole circles of from 3 to 28 holes. Dimensional arc for holes numbered in a counterclockwise direction (as shown). Dimensions given are based upon a hole circle of unit diameter. For a hole circle of, say, 3-inch or 3-centimeter diameter, multiply table values by 3.				
$y_3$ -0.39668	$y_3$ -0.40451	$y_3$ -0.41149	$y_3$ -0.41774	$y_3$ -0.42336
$x_4$ -0.39668	$x_4$ -0.38526	$x_4$ -0.37426	$x_4$ -0.36369	$x_4$ -0.35355
$y_4$ -0.20438	$y_4$ -0.31871	$y_4$ -0.23156	$y_4$ -0.24312	$y_4$ -0.25355
$x_5$ -0.46194	$x_5$ -0.45241	$x_5$ -0.44273	$x_5$ -0.43301	$x_5$ -0.42336
$y_5$ -0.19134	$y_5$ -0.21289	$y_5$ -0.23236	$y_5$ -0.25000	$y_5$ -0.26602
$x_6$ -0.49572	$x_6$ -0.49114	$x_6$ -0.48547	$x_6$ -0.47899	$x_6$ -0.47194
$y_6$ -0.06526	$y_6$ -0.09369	$y_6$ -0.11966	$y_6$ -0.14340	$y_6$ -0.16514
$x_7$ -0.49572	$x_7$ -0.49901	$x_7$ -0.50000	$x_7$ -0.49915	$x_7$ -0.49686
$y_7$ +0.06526	$y_7$ +0.03140	$y_7$ 0.00000	$y_7$ -0.02907	$y_7$ -0.05598
$x_8$ -0.46194	$x_8$ -0.47553	$x_8$ -0.48547	$x_8$ -0.49240	$x_8$ -0.49686
$y_8$ +0.19134	$y_8$ +0.15451	$y_8$ +0.11966	$y_8$ +0.08682	$y_8$ +0.05598
$x_9$ -0.39668	$x_9$ -0.42216	$x_9$ -0.44273	$x_9$ -0.45911	$x_9$ -0.47194
$y_9$ +0.30438	$y_9$ +0.26791	$y_9$ +0.23236	$y_9$ +0.19804	$y_9$ +0.16514
$x_{10}$ -0.30438	$x_{10}$ -0.34227	$x_{10}$ -0.37426	$x_{10}$ -0.40106	$x_{10}$ -0.42336
$y_{10}$ +0.39668	$y_{10}$ +0.36448	$y_{10}$ +0.33156	$y_{10}$ +0.29838	$y_{10}$ +0.26602
$x_{11}$ -0.19134	$x_{11}$ -0.24088	$x_{11}$ -0.28403	$x_{11}$ -0.32139	$x_{11}$ -0.35355
$y_{11}$ +0.46194	$y_{11}$ +0.43815	$y_{11}$ +0.41149	$y_{11}$ +0.38302	$y_{11}$ +0.35355
$x_{12}$ -0.06526	$x_{12}$ -0.12434	$x_{12}$ -0.17730	$x_{12}$ -0.22440	$x_{12}$ -0.26602
$y_{12}$ +0.49572	$y_{12}$ +0.48429	$y_{12}$ +0.46751	$y_{12}$ +0.44682	$y_{12}$ +0.42336
$x_{13}$ +0.06526	$x_{13}$ 0.00000	$x_{13}$ -0.06027	$x_{13}$ -0.11531	$x_{13}$ -0.16514
$y_{13}$ -0.49572	$y_{13}$ +0.50000	$y_{13}$ +0.49635	$y_{13}$ +0.48652	$y_{13}$ +0.47194
$x_{14}$ +0.19134	$x_{14}$ +0.12434	$x_{14}$ +0.06027	$x_{14}$ 0.00000	$x_{14}$ -0.05598
$y_{14}$ +0.46194	$y_{14}$ +0.48429	$y_{14}$ +0.49635	$y_{14}$ +0.50000	$y_{14}$ +0.49686
$x_{15}$ +0.30438	$x_{15}$ +0.24088	$x_{15}$ +0.17730	$x_{15}$ +0.11531	$x_{15}$ +0.05598
$y_{15}$ +0.39668	$y_{15}$ +0.43815	$y_{15}$ +0.46751	$y_{15}$ +0.48652	$y_{15}$ +0.49686
$x_{16}$ +0.39668	$x_{16}$ +0.34227	$x_{16}$ +0.28403	$x_{16}$ +0.22440	$x_{16}$ +0.16514
$y_{16}$ +0.30438	$y_{16}$ +0.36448	$y_{16}$ +0.41149	$y_{16}$ +0.44682	$y_{16}$ +0.47194
$x_{17}$ +0.46194	$x_{17}$ +0.42216	$x_{17}$ +0.37426	$x_{17}$ +0.32139	$x_{17}$ +0.26602
$y_{17}$ +0.19134	$y_{17}$ +0.26791	$y_{17}$ +0.33156	$y_{17}$ +0.38302	$y_{17}$ +0.42336
$x_{18}$ +0.49572	$x_{18}$ +0.47553	$x_{18}$ +0.44273	$x_{18}$ +0.40106	$x_{18}$ +0.35355
$y_{18}$ -0.06526	$y_{18}$ +0.15451	$y_{18}$ +0.23236	$y_{18}$ +0.29838	$y_{18}$ +0.35355
$x_{19}$ +0.49572	$x_{19}$ +0.49901	$x_{19}$ +0.48547	$x_{19}$ +0.45911	$x_{19}$ +0.42336
$y_{19}$ -0.06526	$y_{19}$ +0.03140	$y_{19}$ -0.11966	$y_{19}$ +0.19804	$y_{19}$ +0.26602
$x_{20}$ +0.46194	$x_{20}$ +0.49114	$x_{20}$ +0.50000	$x_{20}$ +0.49240	$x_{20}$ +0.47194
$y_{20}$ -0.19134	$y_{20}$ -0.09369	$y_{20}$ 0.00000	$y_{20}$ +0.08682	$y_{20}$ +0.16514
$x_{21}$ +0.39668	$x_{21}$ +0.45241	$x_{21}$ +0.48547	$x_{21}$ +0.49915	$x_{21}$ +0.49686
$y_{21}$ -0.30438	$y_{21}$ -0.21289	$y_{21}$ -0.11966	$y_{21}$ -0.02907	$y_{21}$ -0.05598
$x_{22}$ +0.30438	$x_{22}$ +0.38526	$x_{22}$ +0.44273	$x_{22}$ +0.47899	$x_{22}$ +0.49686
$y_{22}$ -0.39668	$y_{22}$ -0.31871	$y_{22}$ -0.23236	$y_{22}$ -0.14340	$y_{22}$ -0.05598
$x_{23}$ +0.19134	$x_{23}$ +0.29389	$x_{23}$ +0.37426	$x_{23}$ +0.43301	$x_{23}$ +0.47194
$y_{23}$ -0.46194	$y_{23}$ -0.40451	$y_{23}$ -0.33156	$y_{23}$ -0.25000	$y_{23}$ -0.16514
$x_{24}$ +0.06526	$x_{24}$ +0.18406	$x_{24}$ +0.28403	$x_{24}$ +0.36369	$x_{24}$ +0.42336
$y_{24}$ -0.49572	$y_{24}$ -0.46489	$y_{24}$ -0.41149	$y_{24}$ -0.34312	$y_{24}$ -0.26602
	$y_{25}$ +0.06267	$y_{25}$ +0.17730	$y_{25}$ +0.27475	$y_{25}$ +0.35355
	$y_{25}$ -0.49606	$y_{25}$ -0.46751	$y_{25}$ -0.41774	$y_{25}$ -0.35355
		$x_{26}$ +0.06027	$x_{26}$ +0.17101	$x_{26}$ +0.26602
		$y_{26}$ -0.49635	$y_{26}$ -0.46985	$y_{26}$ -0.42336
			$x_{27}$ +0.05805	$x_{27}$ +0.16514
			$y_{27}$ -0.49662	$y_{27}$ -0.47194
				$x_{28}$ +0.05598
				$y_{28}$ -0.49686

Collets

Collets for Lathes, Mills, Grinders, and Fixtures

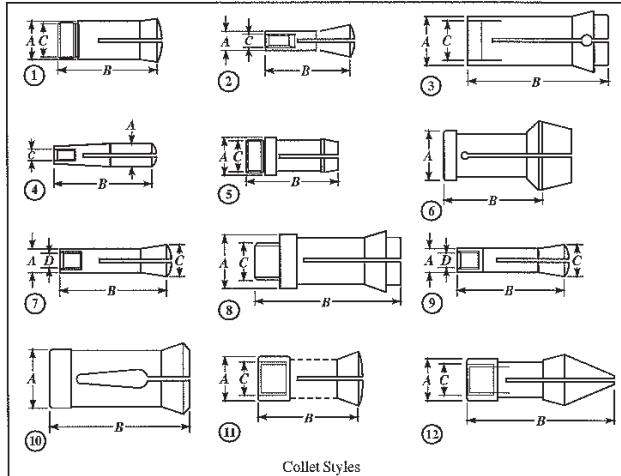

Collet Styles

Collets for Lathes, Mills, Grinders, and Fixtures

Collet	Style	Dimensions			Max. Capacity (inches)		
		Bearing Diam., A	Length, B	Thread, C	Round	Hex	Square
1A	1	0.650	2.563	0.640 × 26 RH	0.500	0.438	0.344
1AM	1	1.125	3.906	1.118 × 24 RH	1.000	0.875	0.719
1B	2	0.437	1.750	0.312 × 30 RH	0.313	0.219	0.188
1C	1	0.335	1.438	0.322 × 40 RH	0.250	0.219	0.172
1J	1	1.250	3.000	1.238 × 20 RH	1.063	0.875	0.750
1K	3	1.250	2.813	None	1.000	0.875	0.719
2A	1	0.860	3.313	0.850 × 20 RH	0.688	0.594	0.469
2AB	2	0.750	2.563	0.500 × 20 RH	0.625	0.484	0.391
2AM	1	0.629	3.188	0.622 × 24 RH	0.500	0.438	0.344
2B	2	0.590	2.031	0.437 × 26 RH	0.500	0.438	0.344
2C	1	0.450	1.812	0.442 × 30 RH	0.344	0.594	0.234
2H	1	0.826	4.250	0.799 × 20 RH	0.625	0.531	1.000
2J	1	1.625	3.250	1.611 × 18 RH	1.375	1.188	0.438
2L	1	0.950	3.000	0.938 × 20 RH	0.750	0.656	1.000
2M	4	2 Morse	2.875	0.375 × 16 RH	0.500	0.438	0.344
2NS	1	0.324	1.562	0.318 × 40 RH	0.250	0.203	0.172
2OS	1	0.299	1.250	0.263 × 40 RH	0.188	0.156	0.125
2S	1	0.750	3.234	0.745 × 18 RH	0.563	0.484	0.391
2VB	2	0.595	2.438	0.437 × 26 RH	0.500	0.438	0.344
3AM	1	0.750	3.188	0.742 × 24 RH	0.625	0.531	0.438
3AT	1	0.687	2.313	0.637 × 26 RH	0.500	0.438	0.344

## Collets for Lathes, Mills, Grinders, and Fixtures (Continued)

Collet	Style	Dimensions			Max. Capacity (inches)		
		Bearing Diam., A	Length, B	Thread, C	Round	Hex	Square
3B	2	0.875	3.438	0.625 × 16 RH	0.750	0.641	0.531
3C	1	0.650	2.688	0.640 × 26 RH	0.500	0.438	0.344
3H	1	1.125	4.438	1.050 × 20 RH	0.875	0.750	0.625
3J	1	2.000	3.750	1.988 × 20 RH	1.750	1.500	1.250
3NS	1	0.687	2.875	0.647 × 20 RH	0.500	0.438	0.344
3OS	1	0.589	2.094	0.518 × 26 RH	0.375	0.313	0.266
3PN	1	0.650	2.063	0.645 × 24 RH	0.500	0.438	0.344
3PO	1	0.599	2.063	0.500 × 24 RH	0.375	0.313	0.266
3S	1	1.000	4.594	0.995 × 20 RH	0.750	0.656	0.531
3SC	1	0.350	1.578	0.293 × 36 RH	0.188	0.156	0.125
3SS	1	0.589	2.125	0.515 × 26 RH	0.375	0.313	0.266
4C	1	0.950	3.000	0.938 × 20 RH	0.750	0.656	0.531
4NS	1	0.826	3.500	0.800 × 20 RH	0.625	0.531	0.438
4OS	1	0.750	2.781	0.660 × 20 RH	0.500	0.438	0.344
4PN	1	1.000	2.906	0.995 × 16 RH	0.750	0.656	0.531
4S	1	0.998	3.250	0.982 × 20 RH	0.750	0.656	0.531
5C	1	1.250	3.281	1.238 × 20 RH*	1.063	0.906	0.750
5M	5	1.438	3.438	1.238 × 20 RH	0.875	0.750	0.625
5NS	1	1.062	4.219	1.050 × 20 RH	0.875	0.750	0.625
5OS	1	3.500	3.406	0.937 × 18 RH	0.750	0.641	0.516
5P	1	0.812	3.687	0.807 × 24 RH	0.625	0.531	0.438
5PN	1	1.312	3.406	1.307 × 16 RH	1.000	0.875	0.719
5SC	1	0.600	2.438	0.500 × 26 RH	0.375	0.328	0.266
5ST	1	1.250	3.281	1.238 × 20 RH	1.063	0.906	0.750
5V	1	0.850	3.875	0.775 × 18 RH	0.563	0.484	0.391
6H	1	1.375	4.750	1.300 × 10 RH	1.125	0.969	0.797
6K	1	0.842	3.000	0.762 × 26 RH	0.625	0.531	0.438
6L	1	1.250	4.438	1.178 × 20 RH	1.000	0.875	0.719
6NS	1	1.312	5.906	1.234 × 14 RH	1.000	0.859	0.703
6R	1	1.375	4.938	1.300 × 20 RH	1.125	0.969	0.781
7B	4	7 B&S	3.125	0.375 × 16 RH	0.500	0.406	0.344
7 B&S	4	7 B&S	2.875	0.375 × 16 RH	0.500	0.406	0.344
7P	1	1.125	4.750	1.120 × 20 RH	0.875	0.750	0.625
7R	6	1.062	3.500	None	0.875	0.750	0.625
8H	1	1.500	4.750	1.425 × 20 RH	1.250	1.063	0.875
8ST	1	2.375	5.906	2.354 × 12 RH	2.125	1.844	1.500
8WN	1	1.250	3.875	1.245 × 16 RH	1.000	0.875	0.719
9B	4	9 B&S	4.125	0.500 × 13 RH	0.750	0.641	0.531
10L	1	1.562	5.500	1.490 × 18 RH	1.250	1.063	0.875
10P	1	1.500	4.750	1.495 × 20 RH	1.250	1.063	0.875
16C	1	1.889	4.516	1.875 × 1.75 mm RHP	1.625	1.406	1.141
20W	1	0.787	2.719	0.775 × 6-1 cm	0.563	0.484	0.391
22J	1	2.562	4.000	2.550 × 18 RH	2.250	1.938	1.563
32S	1	0.703	2.563	0.690 × 24 RH	0.500	0.438	0.344
35J	1	3.875	5.000	3.861 × 18 RH	3.500	3.000	2.438
42S	1	1.250	3.688	1.236 × 20 RH	1.000	0.875	0.719
50V	8	1.250	4.000	1.125 × 24 RH	0.938	0.813	0.656
52SC	1	0.800	3.688	0.795 × 20 RH	0.625	0.531	0.438
115	1	1.344	3.500	1.307 × 20 LH	1.125	0.969	0.797

Collets for Lathes, Mills, Grinders, and Fixtures (Continued)

Collet	Style	Dimensions			Max. Capacity (inches)		
		Bearing Diam., A	Length, B	Thread, C	Round	Hex	Square
215	1	2.030	4.750	1.990 × 18 LH	1.750	1.500	1.219
315	1	3.687	5.500	3.622 × 16 LH	3.250	2.813	2.250
B3	7	0.650	3.031	0.437 × 20 RH	0.500	0.438	0.344
D5	7	0.780	3.031	0.500 × 20 RH	0.625	0.531	0.438
GTM	7	0.625	2.437	0.437 × 20 RH	0.500	0.438	0.344
J&L	9	0.999	4.375	None	0.750	0.641	0.516
JC	8	1.360	4.000	None	1.188	1.000	0.813
LB	10	0.687	2.000	None	0.500	0.438	0.344
RO	11	1.250	2.938	0.875 × 16 RH	1.125	0.969	0.781
RO	12	1.250	4.437	0.875 × 16 RH	0.800	0.688	0.563
RO	12	1.250	4.437	0.875 × 16 RH	1.125	0.969	0.781
RO	11	1.250	2.938	0.875 × 16 RH	0.800	0.688	0.563
R8	7	0.950	4.000	0.437 × 20 RH	0.750	0.641	0.531

<sup>a</sup>Internal stop thread is 1.041 × 24 RH.

<sup>b</sup>Internal stop thread is 1.687 × 20 RH.

Dimensions in inches unless otherwise noted. Courtesy of Hardinge Brothers, Inc.

DIN 6388, Type B, and DIN 6499, ER Type Collets

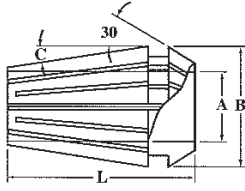
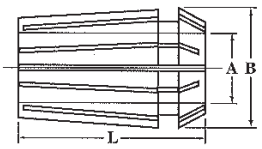
Collet Standard	Type	Dimensions			
		B (mm)	L (mm)	A (mm)	C
Type B, DIN 6388	16	25.50	40	4.5-16	...
	20	29.80	45	5.5-20	...
	25	35.05	52	5.5-25	...
	32	43.70	60	9.5-32	...
ER Type, DIN 6499	ERA8	8.50	13.5	0.5-5	8°
	ERA11	11.50	18	0.5-7	8°
	ERA16	17	27	0.5-10	8°
	ERA20	21	31	0.5-13	8°
	ERA25	26	35	0.5-16	8°
	ERA32	33	40	2-20	8°
	ERA40	41	46	3-26	8°
	ERA40	41	39	26-30	8°
ERA50	52	60	5-34	8°	