

[54] PROSTHETIC TISSUE HEART VALVE

[75] Inventors: Marian I. Ionescu, Leeds, England; Bruce E. Fettel, Diamond Bar, Calif.

[73] Assignee: Shiley Laboratories, Incorporated, Santa Ana, Calif.

[21] Appl. No.: 679,406

[22] Filed: Apr. 22, 1976

[51] Int. Cl.² A61F 1/22

[52] U.S. Cl. 3/1.5

[58] Field of Search 3/1.5, 1

[56] References Cited

U.S. PATENT DOCUMENTS

3,714,671	2/1973	Edwards	3/1.5
3,755,823	9/1973	Hancock	3/1.5
3,983,581	10/1976	Angell et al.	3/1.5
3,996,623	12/1976	Kaster	3/1.5

FOREIGN PATENT DOCUMENTS

1,264,472	2/1972	United Kingdom	3/1.5
-----------	--------	----------------	-------

OTHER PUBLICATIONS

"Frame-Mounted Tissue Heart Valves: Technique of

Construction" by Ivan T. Bartek et al., *Thorax*, (1974), 29, pp. 51-55.

"Heart Valve Replacement With Autologous Fascia Lata Using the Ionescu Technique" by A. S. Trimble et al., *The Journal of Thoracic & Cardiovascular Surgery*, vol. 61, No. 3, Mar. 1971, pp. 385-392.

"Heart-Valve Replacement With Autologous Fascia Lata," by M. I. Ionescu, *The Lancet*, Aug. 6, 1969, pp. 335-338.

Primary Examiner—Ronald L. Frinks
Attorney, Agent, or Firm—Knobbe, Martens, Olson, Hubbard & Bear

[57] ABSTRACT

A tissue heart valve has a cloth-covered stent which provides several layers of padding over the stent edges and an integral sewing ring while maximizing the internal valve diameter for a given size heart annulus. No edges of the cloth are exposed. A continuation of the pledget covers all knots of the stitches connecting the tissue to the stent.

14 Claims, 9 Drawing Figures

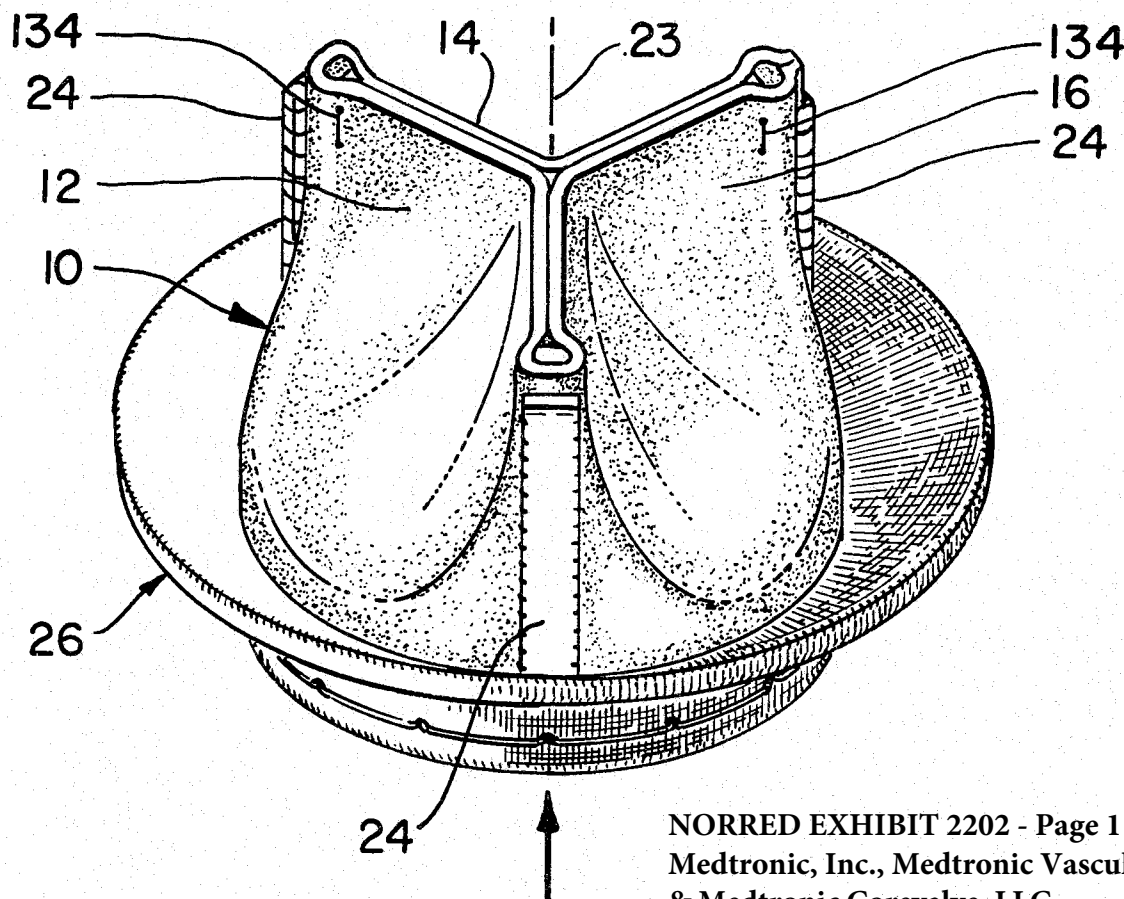

NORRED EXHIBIT 2202 - Page 1
Medtronic, Inc., Medtronic Vascular, Inc.,
& Medtronic Corevalve, LLC
v. Troy R. Norred, M.D.

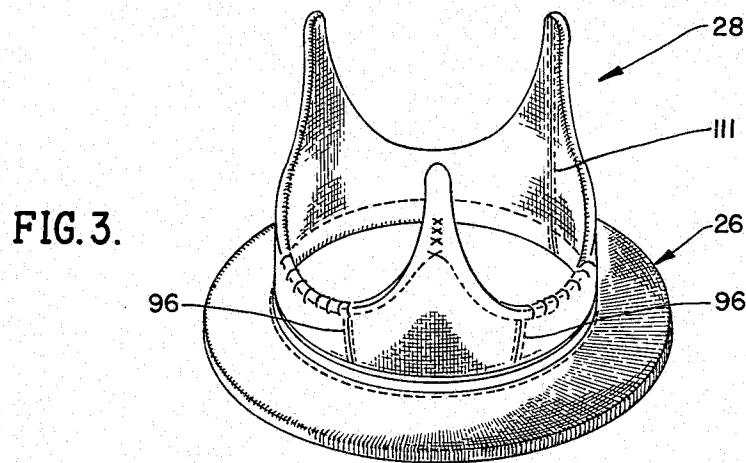
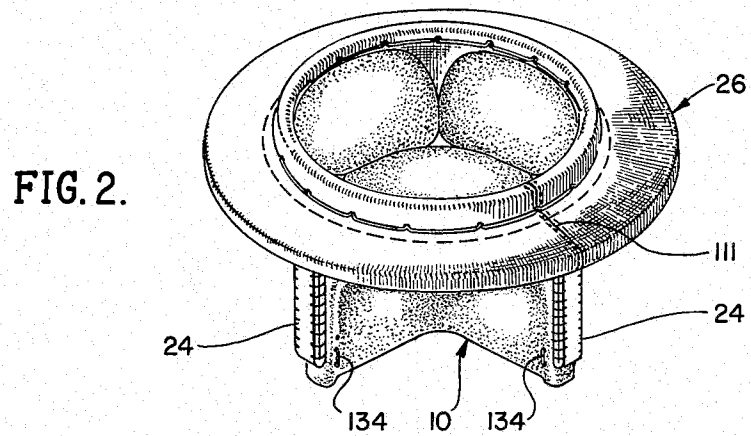
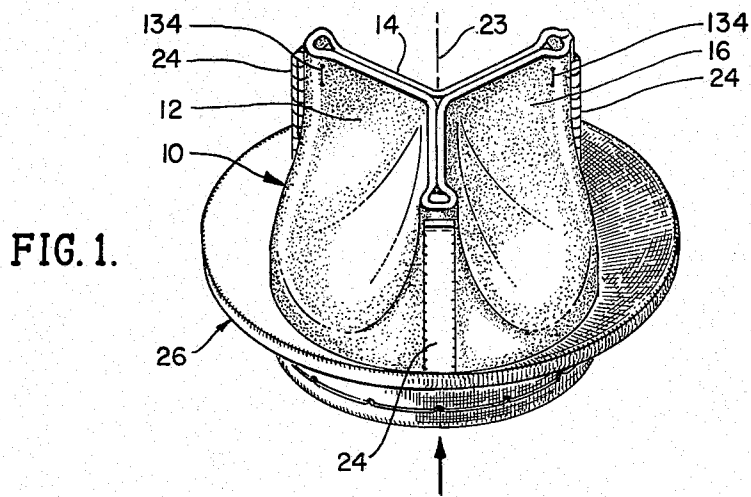

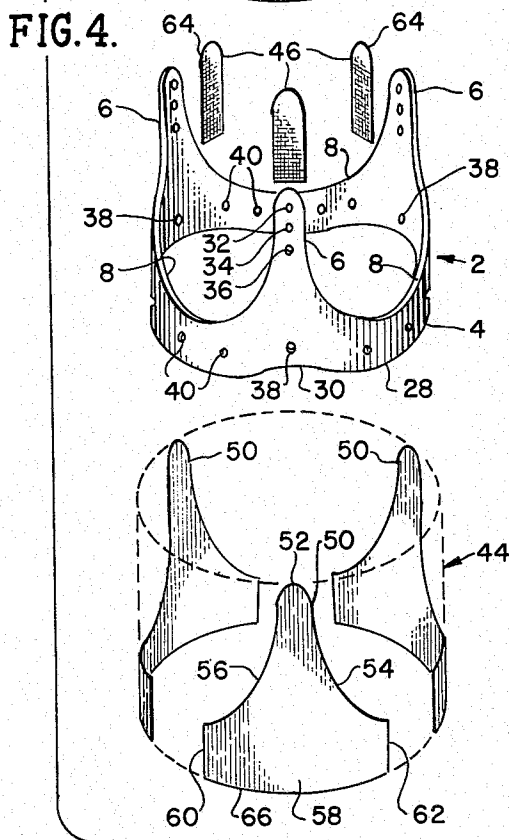
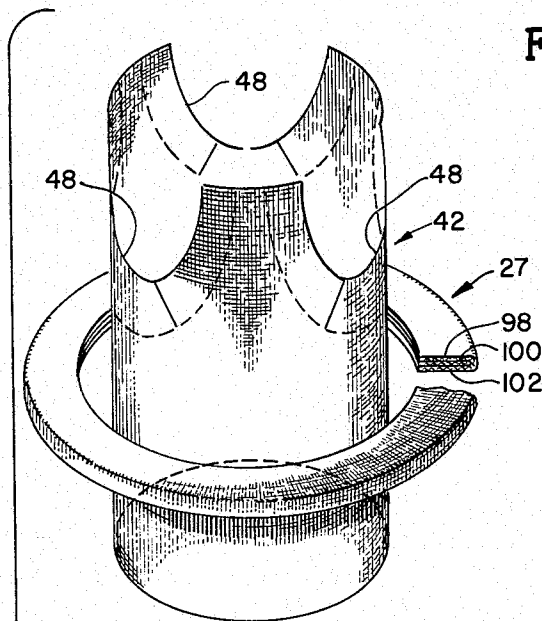

FIG. 5.

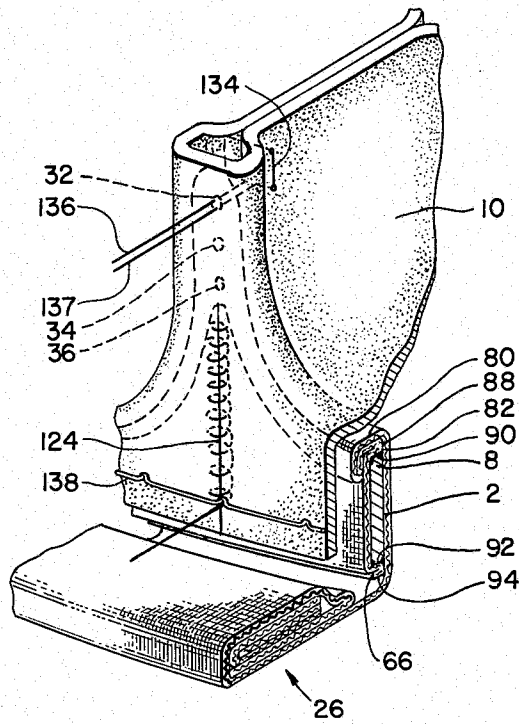
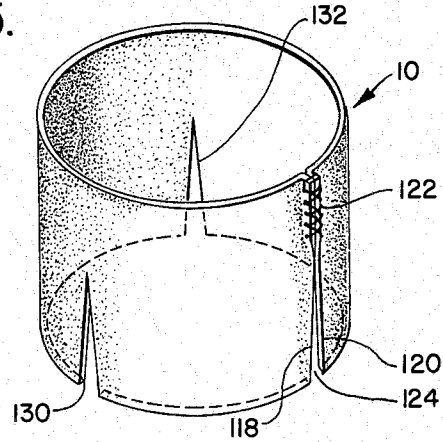

FIG. 6.

FIG. 7.

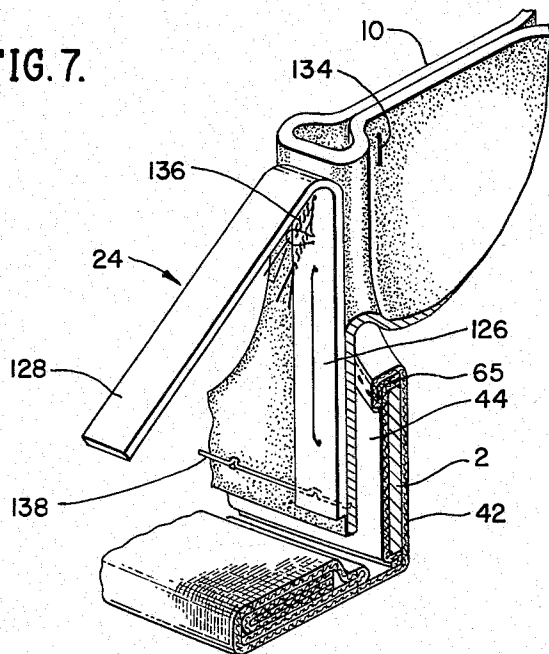

FIG. 8.

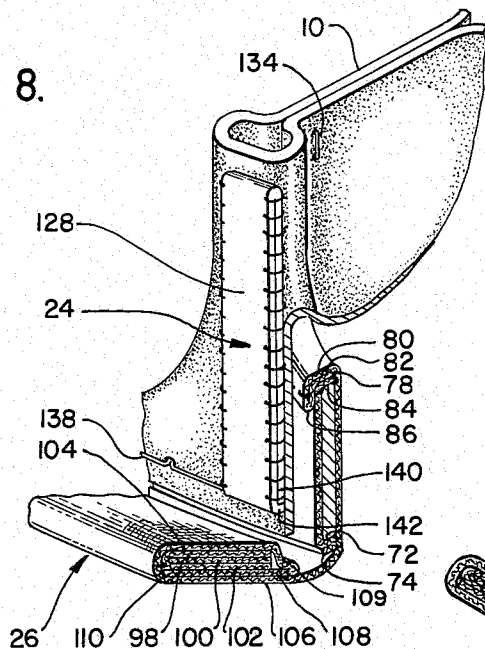
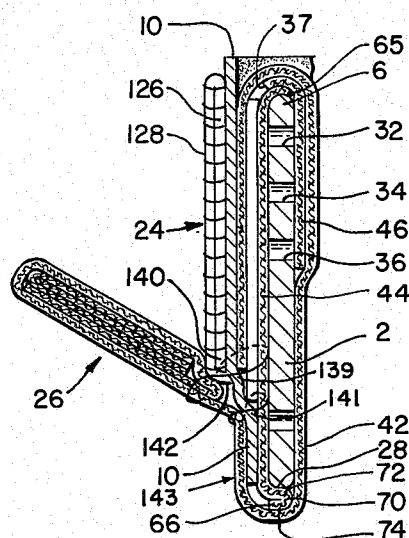

FIG. 9.



PROSTHETIC TISSUE HEART VALVE

BACKGROUND

This invention relates to frame mounted, prosthetic tissue heart valves, and particularly to improvements in the construction of such valves.

Frame-mounted fascia lata heart valves were used clinically by Dr. Marian I. Ionescu and Dr. D. N. Ross in 1969. Since that time hundreds of tissue valves made of autologous or homologous fascia lata, dura mater, or of heterologous pericardium have been implanted. A construction of bovine pericardial valves is reported in *Frame-mounted Tissue Heart Valves: Technique of Construction*, Bartels, Holden and Ionescu, Thorax (1974) 29, 51. As reported in that article, an important factor on which the long-term function of these valves depends is their construction before insertion. This invention is an improved construction over that described in the cited article.

SUMMARY OF INVENTION

This invention is directed to an improved construction principally in the cloth covering for the valve frame or stent by which raw fabric or tissue edges are not exposed to the blood stream, particularly at the valve inlet, added protection is obtained against the frame or stitches tearing through the covering cloth, risk of the sewing ring separating from the valve is eliminated, the stitches attaching the tissue to the stent are covered by cloth, and the thickness of material at the annulus is reduced to increase the ratio of valve internal diameter to external valve diameter, and therefore to internal diameter of the heart annulus receiving the valve.

Accordingly, this invention provides a prosthetic tissue heart valve in which a continuation of the pledget covers the knots of the threads used to stitch the tissue to the stent. This invention also provides a construction wherein the interior fabric cover is integral with the sewing ring or cuff. Further in accordance with this invention several layers of padding are provided along the edges of the stent where tearing is most likely and cushioning is desirable, yet only three layers of cloth add to the thickness of the stent at the bottom portion which fits in the heart annulus. Moreover, this invention provides a novel construction wherein no edges of the cloth fabric covering the stent are exposed to the blood-stream.

DESCRIPTION OF DRAWINGS

FIG. 1 is a perspective view of a completed valve;
FIG. 2 is a perspective view of the same completed valve inverted;

FIG. 3 is a perspective view of the stent covered with cloth and ready to receive the tissue, with the sewing ring turned down to show certain construction details;

FIG. 4 is an exploded perspective view of the elements used in constructing the cloth covered stent;

FIG. 5 is a perspective view of the tissue ready to be placed on the cloth covered stent of FIG. 3;

FIG. 6 is a perspective view, partially in section, of the valve with portions removed;

FIG. 7 is a perspective view, partially in section, of a portion of a partially assembled valve;

FIG. 8 is a perspective view, partially in section, of a portion of a partially completed valve; and

FIG. 9 is a sectional view, through the valve at a post of a completed valve.

Referring to FIG. 4, the valve includes a thin-walled stent 2 having an annular base 4 and three equally spaced upright posts 6 with scalloped upper edges 8 on the stent between posts 6. Throughout this application the term upper will be used for convenience to refer to the outflow end of the valve and lower will be used to refer to the inflow side, recognizing that the valve may not be upright where installed. Also, the term upper edge of the stent is used to include the side edges of the posts 6. Referring now to FIG. 1 the stent supports a tissue valve element 10 which surrounds the stent and has three cusps 12, 14, and 16 meeting along their upper edge portions in the closed position. The cusps are free to separate when the pressure below the valve exceeds that above to pass blood through the valve in a known manner. The flow of blood is from bottom to top in FIG. 1 along the axis 23 of the valve. Applicants refer to the article cited above in the application for a more complete description of the tissue and its assembly and operation.

A pledget and cover 24 extends down the outside of the tissue at each post, and a sewing ring or cuff 26 is provided for grafting the prosthetic valve into the heart valve annulus using well known surgical procedures.

Referring again to FIG. 4, the stent may be constructed of any of the known materials, suitable for cloth covered prosthetic heart valves, titanium or nickel-cobalt alloy or Teflon or Delvon plastic being among the alternatives available. Its bottom edge 28 preferably is slightly scalloped having its high points 30 beneath the posts 6. Each post 6 has sewing holes, 32, 34, and 36 three in the illustrated embodiment, spaced vertically near its upper end. Additional sewing holes 38, and 40 are spaced around the circumference of the base. In the illustrated embodiment the base 4 has one sewing hole 38 at the base of each post and five 40 between adjacent posts, but that number can be varied, as can the number on the posts.

The cloth covering preferably is of Dacron velour and includes an inner sleeve 42, a three piece outer sleeve 44, and three interior post sewing pads 46. The inner sleeve originally is of a cylindrical shape with scallops 48 removed as shown in FIG. 4, corresponding generally with the scallops 8 on the upper edge of the stent. The outside diameter of the inner sleeve is about the same as the inside diameter of the stent base 4. The outer sleeve pieces 44 can advantageously be cut from a cylinder of cloth to the shape shown, such that each has a post portion 50 with a rounded top 52 and two scalloped side edges 54, 56 and a base portion 58 with straight side edges 60, 62. The interior post pads 46 are each a short length of fabric of the same width as the posts 6 and having a rounded top 64.

Referring to FIGS. 8 and 9, three outer sleeve pieces 44 are each located on the outside of a respective stent post 6 and folded over the scalloped edges 8 and top of the stent post terminating at 78 flush with the inside surface of the stent. The three outer cloth pieces 44 do not cover the outside of the stent base 4 between the regions of the posts 6 as is evident from the spaces shown in FIG. 4, but extend to the seams 96 shown in FIG. 3. As best shown in FIG. 9, the bottom edge 66 of each outer sleeve piece is folded over the bottom edge 28 of the stent and then folded back at 70 to form a two layer 72, 74 pad at the bottom edge 28 and terminates at 66 about flush with the outer surface of the stent.

Explore Litigation Insights

Docket Alarm provides insights to develop a more informed litigation strategy and the peace of mind of knowing you're on top of things.

Real-Time Litigation Alerts



Keep your litigation team up-to-date with **real-time alerts** and advanced team management tools built for the enterprise, all while greatly reducing PACER spend.

Our comprehensive service means we can handle Federal, State, and Administrative courts across the country.

Advanced Docket Research



With over 230 million records, Docket Alarm's cloud-native docket research platform finds what other services can't. Coverage includes Federal, State, plus PTAB, TTAB, ITC and NLRB decisions, all in one place.

Identify arguments that have been successful in the past with full text, pinpoint searching. Link to case law cited within any court document via Fastcase.

Analytics At Your Fingertips



Learn what happened the last time a particular judge, opposing counsel or company faced cases similar to yours.

Advanced out-of-the-box PTAB and TTAB analytics are always at your fingertips.

API

Docket Alarm offers a powerful API (application programming interface) to developers that want to integrate case filings into their apps.

LAW FIRMS

Build custom dashboards for your attorneys and clients with live data direct from the court.

Automate many repetitive legal tasks like conflict checks, document management, and marketing.

FINANCIAL INSTITUTIONS

Litigation and bankruptcy checks for companies and debtors.

E-DISCOVERY AND LEGAL VENDORS

Sync your system to PACER to automate legal marketing.