

**United States Patent** [19]

Totten et al.

[11] **Patent Number:** 4,477,930

[45] **Date of Patent:** Oct. 23, 1984

- [54] **NATURAL TISSUE HEAT VALVE AND METHOD OF MAKING SAME**
- [75] **Inventors:** Robert P. Totten; Gail S. Totten, both of Denver, Colo.; Mary A. Wilson, San Jose, Calif.
- [73] **Assignee:** Mitral Medical International, Inc., Wheat Ridge, Colo.
- [21] **Appl. No.:** 425,553
- [22] **Filed:** Sep. 28, 1982
- [51] **Int. Cl.<sup>3</sup>** ..... A61F 1/22
- [52] **U.S. Cl.** ..... 3/1.5
- [58] **Field of Search** ..... 3/1.5, 1

3,755,823	9/1973	Hancock .....	3/1.5
3,983,581	10/1976	Angell et al. ....	3/1.5
4,035,849	7/1977	Angell et al. ....	3/1.5
4,084,268	4/1978	Ionesco et al. ....	3/1.5
4,172,295	10/1979	Batten .....	3/1.5

*Primary Examiner*—Ronald L. Frinks  
*Attorney, Agent, or Firm*—John E. Reilly

[57] **ABSTRACT**

A low profile natural tissue heart valve with a one-piece fabric covering is applied to a stent in a minimum number of steps so that virtually no seams are exposed. The one-piece covering serves also to enclose and mount the sewing ring to avoid separation from the stent. The procedure employed enables use of bovine pericardium united as a single piece to the exterior of the stent and fixed in position in such a way as to avoid prolapsing in use.

[56] **References Cited**  
**U.S. PATENT DOCUMENTS**

3,548,418	12/1970	Angell et al. ....	3/1.5
3,655,306	4/1972	Ross et al. ....	3/1.5 X
3,739,402	6/1973	Cooley et al. ....	3/1.5

**18 Claims, 10 Drawing Figures**

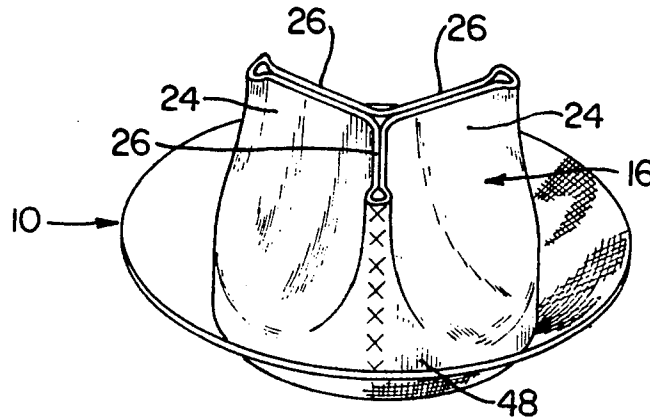

NORRED EXHIBIT 2203 - Page 1  
Medtronic, Inc., Medtronic Vascular, Inc.,  
& Medtronic Corevalve, LLC  
v. Troy R. Norred, M.D.

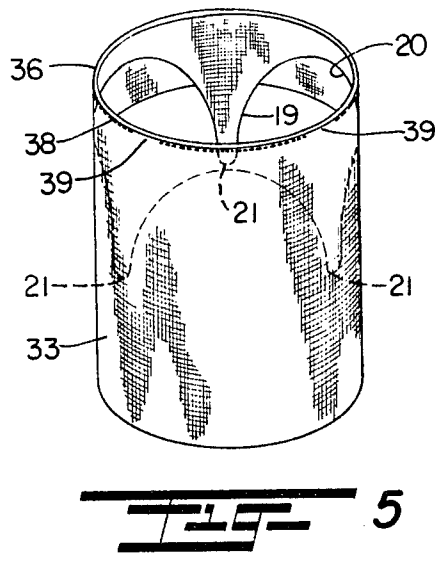
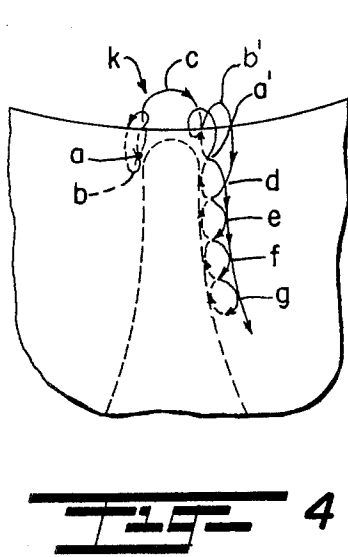
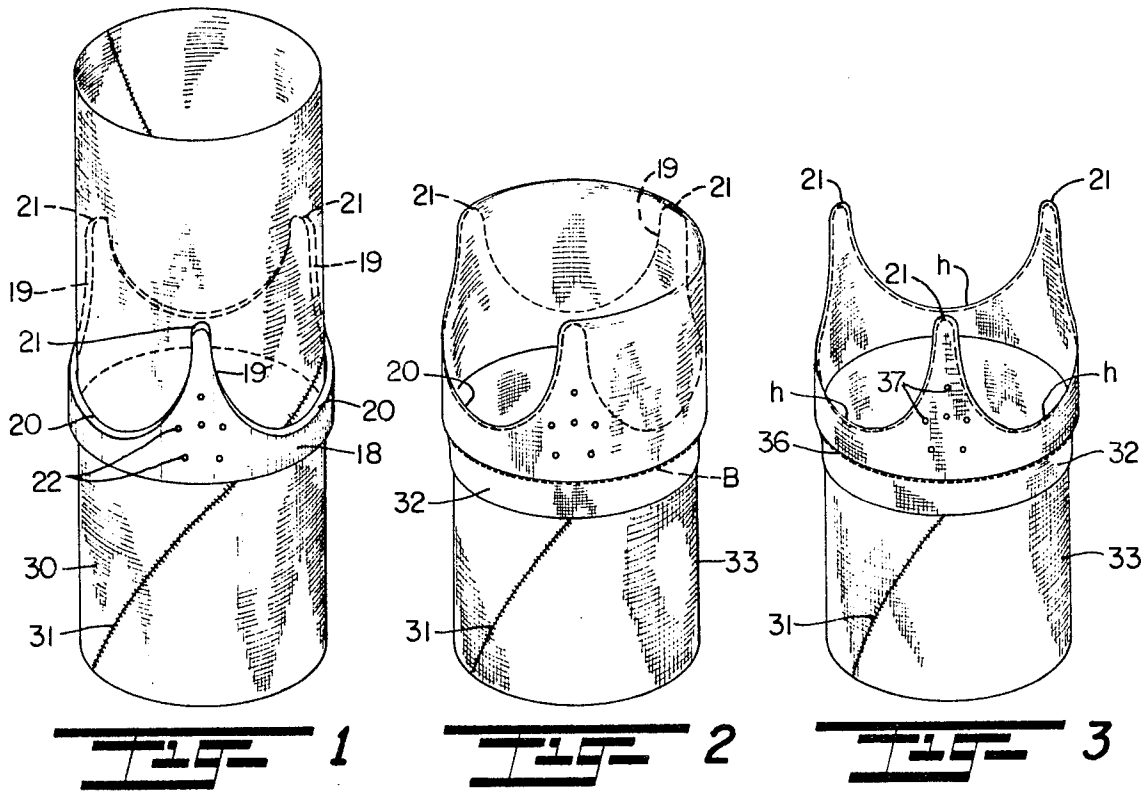

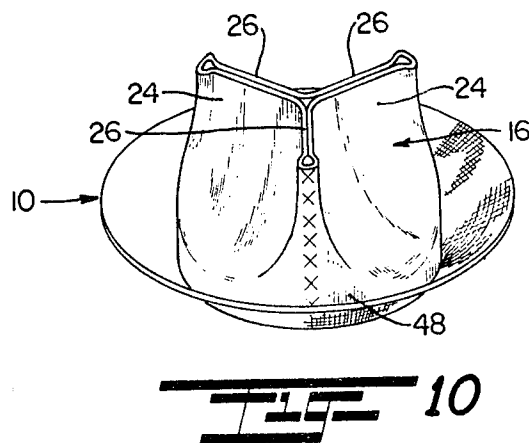
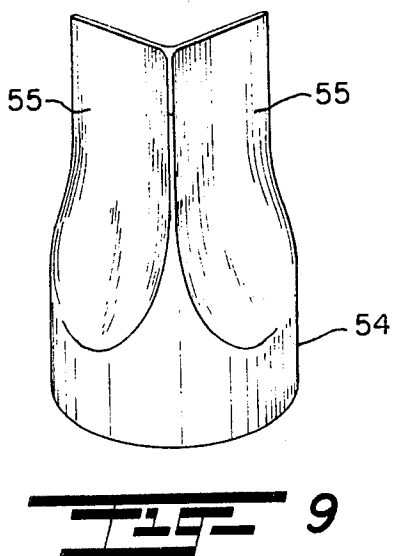
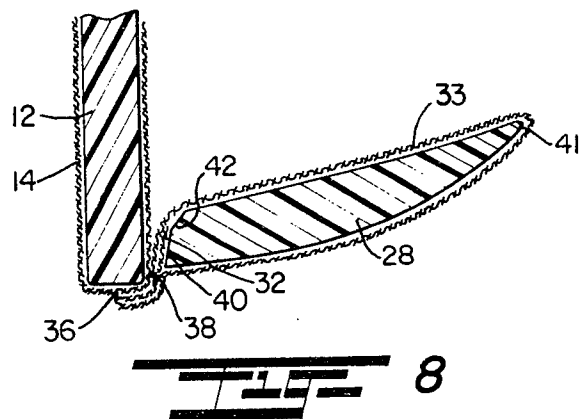
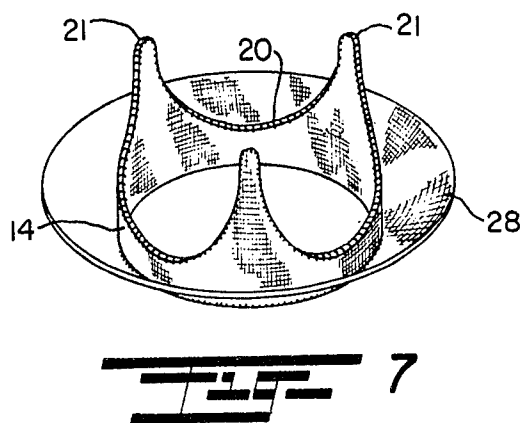
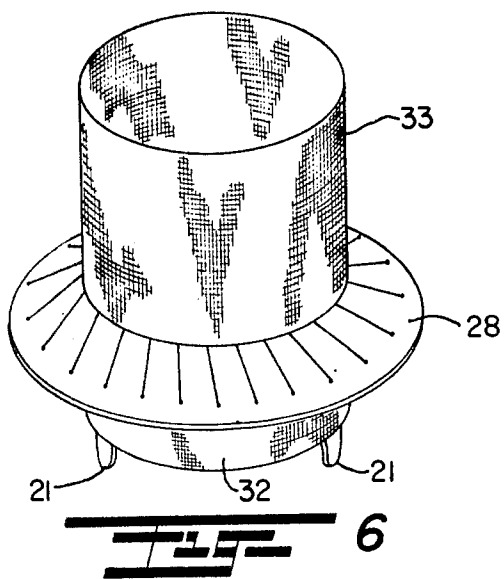

## NATURAL TISSUE HEAT VALVE AND METHOD OF MAKING SAME

This invention relates to tissue valves; and more particularly relates to a novel and improved, low profile, natural tissue heart valve and to the method of making same.

### BACKGROUND AND FIELD OF THE INVENTION

This invention is directed to certain improvements in the construction and method of fabrication of natural tissue heart valves of the type characterized by having a cloth or fabric covered stent which incorporates a suture ring at its base so as to facilitate its implantation into the annulus or wall of the heart using conventional surgical procedures. The valve element itself is composed of pericardium which is mounted upon and sewn to the stent and, for example, in a semicircular heart valve is so configured as to define three cusps which will undergo opening and closing in response to reversals in the flow of blood through the annulus.

In the construction of natural tissue heart valves, it is important that the valve have a low profile and specifically that the tissue valve support posts on the stent be as short as possible so as to avoid rupture of the ventricular wall. Low profile porcine valves have been devised but have not been found to possess the optimum hydrodynamic characteristics desirable in a tissue valve. Bovine pericardium has been employed in the past as the tissue valve for enhanced hydrodynamic performance but has been placed along the interior of the stent in order to effect the necessary support of the valve. A greater effective orifice area can be achieved if the bovine pericardium can be supported around the exterior of the stent and fabric covering while avoiding the necessity of making the stent unduly rigid or inflexible; and further if the necessary stitching or anchoring of the tissue or pericardium be performed between the tissue and exterior of the stent so that the leaflets can open as wide as possible while leaving a smooth interior thereby achieving a lower pressure drop. Thus, a closely-related consideration in the construction of the valve is that the stitching employed between the cloth covering, stent, sewing ring and tissue be uniform or symmetrical throughout and in such a way as to avoid the introduction of increased bulk or non-uniformities in thickness at any point as well as to eliminate any exposed seams or fabric edges. Achievement of the foregoing will then permit utilization of a single piece of tissue as the valve element which can be securely mounted in place onto the cloth-covered stent while maintaining a uniform internal diameter when the tissue valve element is expanded to its open position.

Previously, it has been the practice to employ pressure fixation in the pre-forming of the tissue valve element. However, it is desirable to avoid pressure fixation so as not to affect the collagen bundles in the tissue and in general to provide for an improved method of fixation of the tissue valve element with respect to the cloth-covered stent.

Representative patents of interest in the fabrication and construction of natural tissue heart valves are U.S. Pat. Nos. 3,548,418, 3,983,581 and 4,035,849 to W. W. Angell et al; 4,084,268 to M. I. Ionescu et al; and 4,172,295 to R. J. Batten.

### SUMMARY OF THE INVENTION

Among the desirable objectives and advantages of the present invention in the construction of natural tissue heart valves is the formation of a low profile valve with a one-piece fabric covering applied to a stent in a minimum number of steps so that no raw seams or edges are exposed and wherein the one-piece covering will serve also to enclose and mount the sewing ring in place so as to avoid separation of the sewing ring from the stent. The procedure employed further enables the use of a pericardium or tissue which is united as a single piece element to the stent in such a way as not to pro-lapse in use.

In carrying out the teachings of the present invention, a single piece of fabric is formed into a tube which is sized for insertion within a circular mounting frame having a series of circumferentially spaced commissure posts, the latter separated by curved depressions or scalloped portions above a common annular base. One end of the tube is folded over the posts or tips leaving the longer portion of the tube inside of the stent. The folded-over portion of the tube is then stitched in closely surrounding relation to the posts and intervening scallops, after which the excess material is trimmed and the tubular portions inverted or turned inside out so as to place the seam inside of the inner and outer tube portions. The stent is reinserted into the scalloped tubular portion between the skirts, and the skirts are sewn together along the lower edge of the base of the stent followed by anchor stitching the outer skirt portion through sewing holes formed at spaced intervals within the body of each post. The remaining lengths of the skirt portions extending beyond the base stitching are then drawn over the outside of the stent and stitched together along a second base line of the skirt. An elastomeric sewing ring is inserted between the skirts so as to rest against the second base line and the longer skirt folded over the sewing ring and secured to the stent followed by stitching the short skirt to the long skirt.

The pericardium is specially selected and formed into a rectangular section of uniform thickness which is cut from a partially fixed pericardial sac. The rectangular section is secured to the base of the stent directly above the sewing ring with the fibrous outer layer of pericardium oriented to the inflow aspect or direction and with the abutting edges of the rectangular section located midway along one of the commissure posts. A continuous suture line is employed to secure the edge of the rectangular section to the base of the stent covering with knots formed at each of the commissure posts which are then hidden in pockets formed at the time of stent covering. A continuous criss-cross suture line is then formed along each of the posts to secure the tissue thereto while leaving equal amounts of tissue in the depressions or scalloped portions between each of the posts for the formation of the cusps. Fixation of the tissue is carried out with the valves placed on a leaflet form mandrel and immersing in a bath of tissue fixative after which any final trimming is carried out.

Other objects, advantages and features of the present invention will become more readily appreciated and understood when taken together with the following detailed description in conjunction with the accompanying drawings, in which:

### BRIEF DESCRIPTION OF THE DRAWINGS

FIG. 1 is a somewhat isometric view illustrating the first step in the fabrication of a natural tissue heart valve in which a fabric tube is inserted within a circular stent or frame;

FIG. 2 is an isometric view illustrating the seam which is formed between the fabric tube and scalloped edge of the stent;

FIG. 3 is an isometric view showing the folded-over portions of the tube inverted so as to place the seam along the scalloped edges inside followed by anchor stitching of the tube to the base of the stent;

FIG. 4 is an enlarged fragmentary view illustrating the stitching of the fabric to a post;

FIG. 5 is an isometric view with the stent inverted and showing the stitching of a second base line between the outer skirt portion of the tube and the base of the stent;

FIG. 6 is a view illustrating the first step in the anchoring of the sewing ring to the base of the stent;

FIG. 7 is an isometric view of the completed fabric covering and stent;

FIG. 8 is an enlarged cross-sectional view illustrating in more detail the anchoring of the sewing ring in place through the stent and skirt portions of the tube;

FIG. 9 is an isometric view in elevation of the forming tool employed in the mounting of the tissue into the desired configuration with respect to the stent; and

FIG. 10 is an isometric view of a preferred form of natural tissue valve formed in accordance with the present invention.

### DETAILED DESCRIPTION OF THE PREFERRED EMBODIMENT

Referring in more detail to the drawings, there is illustrated in FIGS. 1 to 10 a preferred form of heart valve 10 which is broadly comprised of a stent 12, fabric covering 14 and pericardial tissue valve element 16. As shown in FIG. 1, the stent 12 is made up of an annular base 18 with three circumferentially spaced commissure posts 19 which project in a common direction at equally spaced circumferential intervals from the base and are separated by scallops or curved depressions 20. Preferably, the stent is composed of a plastic material possessing limited resiliency such that the commissure posts 19 are capable of undergoing inward and outward flexing in following the movement of the tissue valve element between the open and closed positions. Requisites of the material employed therefore are that it possess such limited resiliency and is not susceptible to creep. For instance, the stent may be molded from a polypropylene, ultra high density polyethylene, acetyl homo or copolymer materials. When laid out in a flat pattern, depressed areas 20 are of generally elliptical configuration with opposite side edges of the posts diverging away from tips 21 into the depressed areas. A plurality of apertures or sewing holes 22 are formed at spaced intervals to serve as one means of anchoring the fabric covering to the posts in a manner to be hereinafter described. For the purpose of reference, the upstream edge of the completed valve is located at the inflow end or base of the stent while the downstream or outflow end is along the posts 19; and in this relation the stent is arranged with the posts extending in the downstream direction to support the natural tissue element 16 in outer surrounding relation to the posts, the valve element 16 being pre-formed with three cusps 24 as shown

in FIG. 10. As noted from FIG. 10, in the relaxed state the cusps are closed together along their downstream edges 26. However, in response to the flow of blood through the annulus the cusps will expand substantially beyond the full diameter of the stent 12, then under reversal in the flow of blood will return to their relaxed or closed state.

A sewing ring 28 is positioned in outer surrounding relation to the base of the stent and in a manner to be described is integrated into the valve by the fabric covering so as to serve as a secure means of implantation. The ring 28 may be composed of cloth, e.g., felt or a compliant elastomer, e.g., silicone elastomer which, upon grafting or implantation, will together with the covering 14, form a suitable base for fibrous ingrowth; also, the ring is sufficiently pliable as to conform to irregular openings but will assure a snug fit and seal with the wall of the annulus to which it is secured.

In the fabrication of the preferred form of tissue valve, the sequence of steps followed is illustrated in FIGS. 1 to 9 in accordance with the present invention. As illustrated in FIG. 1, a strip of bias cut fabric in the form of a parallelogram is configured into a tube 30 by sewing the raw edges together to form a bias seam 31 and the tube then inserted in close fitting relation within the stent 12 with the longer portion of the tube extending downwardly beyond the base of the stent. As seen from FIG. 2, the upper portion of the tube 30 is folded over the stent and overlaps the lower portion of the tube for a limited distance beyond the base so as to result in a relatively short skirt portion 32 and a longer skirt portion 33 on opposite sides of the stent. The skirt portions are basted together as at B along a circumferential line extending directly beneath the lower edge of the stent with the upper tip portions 21 of the commissure post 19 bearing snugly against the folded edge of the fabric tube. The fabric layers are then stitched along the posts 19 and scalloped edges 20 according to the procedure illustrated in FIGS. 3 and 4 wherein lock knots k are formed on opposite sides of each tip, then drawn together so as to snugly embrace opposite sides of each tip 21. Specifically, each lock knot k is formed by passing the thread through the fabric layers on one side of the tip as at point a and looping the suture or thread back over the frontal surface of the tip and returning it through the fabric layers at point b directly beneath point a and then advancing through the loop formed between a and b and continuing as at c over to the opposite side of the tip. The procedure is repeated on the opposite side of the tip where the thread enters the fabric layers at point a' is looped around through and into point b', then passed through the loop formed as at c' followed by drawing the suture together until the knots are tightly drawn against opposite sides of the tip with the threading c passing over the upper terminal edge of the tip.

After a pair of lock knots k have been formed on opposite sides of a tip, the remaining length of thread c' is then passed through a succession of back stitches as designated at d, e, f and g, this procedure being repeated throughout the length of the scalloped portion until the next commissure post is reached. Again, at the next commissure post, lock knots k are formed on opposite sides of the tip in the same manner as hereinbefore described. After the stitching operation is completed along the posts 19 and scalloped portions 20, the excess fabric along the scalloped portions and posts is trimmed as represented at h directly outside of the seam.

# Explore Litigation Insights

Docket Alarm provides insights to develop a more informed litigation strategy and the peace of mind of knowing you're on top of things.

## Real-Time Litigation Alerts



Keep your litigation team up-to-date with **real-time alerts** and advanced team management tools built for the enterprise, all while greatly reducing PACER spend.

Our comprehensive service means we can handle Federal, State, and Administrative courts across the country.

## Advanced Docket Research



With over 230 million records, Docket Alarm's cloud-native docket research platform finds what other services can't. Coverage includes Federal, State, plus PTAB, TTAB, ITC and NLRB decisions, all in one place.

Identify arguments that have been successful in the past with full text, pinpoint searching. Link to case law cited within any court document via Fastcase.

## Analytics At Your Fingertips



Learn what happened the last time a particular judge, opposing counsel or company faced cases similar to yours.

Advanced out-of-the-box PTAB and TTAB analytics are always at your fingertips.

## API

Docket Alarm offers a powerful API (application programming interface) to developers that want to integrate case filings into their apps.

## LAW FIRMS

Build custom dashboards for your attorneys and clients with live data direct from the court.

Automate many repetitive legal tasks like conflict checks, document management, and marketing.

## FINANCIAL INSTITUTIONS

Litigation and bankruptcy checks for companies and debtors.

## E-DISCOVERY AND LEGAL VENDORS

Sync your system to PACER to automate legal marketing.