

[54] FLEXIBLE STENT FOR HEART VALVE

[75] Inventor: Warren D. Hancock, Santa Ana, Calif.

[73] Assignee: Hancock Laboratories Incorporation, Orange, Calif.

[22] Filed: Apr. 23, 1971

[21] Appl. No.: 136,832

[52] U.S. Cl. 3/1, 3/DIG. 3

[51] Int. Cl. A61f 1/22

[58] Field of Search 3/1, DIG. 3

[56] References Cited

UNITED STATES PATENTS

3,570,014	3/1971	Hancock	3/1
3,197,788	8/1965	Segger	3/1

OTHER PUBLICATIONS

"Heart Valve Replacement With Reinforced Aortic Heterografts" by M. I. Fonescu et al. The Journal of Thoracic & Cardiovascular Surgery, Vol. 56, No. 3, Sept. 1968, pp. 333-348.

"Clinical Experience With Supported Homograft Heart Valve For Mitral and Aortic Valve Replacement" by S. Sugie et al., The Journal of Thoracic & Cardiovascular

Surgery, Vol. 57, No. 4. Apr. 1969, pp. 455-462.

"Pig Aortic Valve as a Replacement for Mitral Valve in the Dog," by W. A. Reed et al., The Journal of Thoracic and Cardiovascular Surgery, Vol. 57, No. 5, May 1969, pp. 663-667.

Primary Examiner—Richard A. Gaudet

Assistant Examiner—Ronald L. Frinks

Attorney—Gausewitz, Carr & Rothenberg

[57] ABSTRACT

An arrangement for heart valves that includes a stent having apexes interconnected by arms, the apexes being deflectable inwardly upon hemodynamic loading of the heart valve for reducing the stress in the valve tissue, the stent being covered by a cloth sleeve which may have an integral bead or flap for attachment to the heart, padding being provided beneath portions of the sleeve for protection, and a reinforcing ring extending around the assembly over the marginal portions of the heart valve, with sutures extending through the reinforcing ring and tissue of the heart valve for forming an attachment to the stent.

27 Claims, 12 Drawing Figures

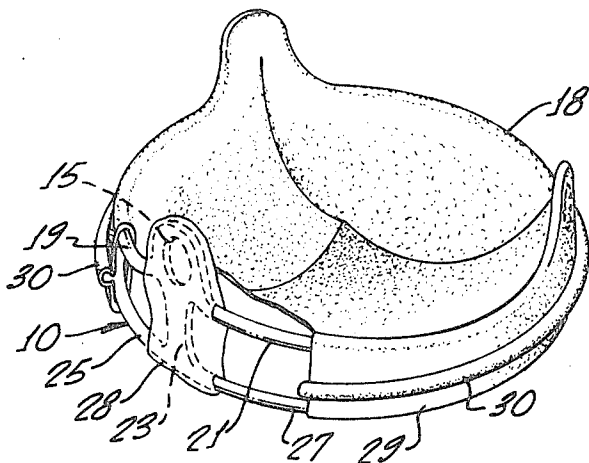

@ADD76 7J: ;4;F \$#00 ZBSYW#
? Wfdh [U;`U? Wfdh [UHSdg`Sd;`U
~ ? Wfdh [U5adMSHM>5

FIG. 1.

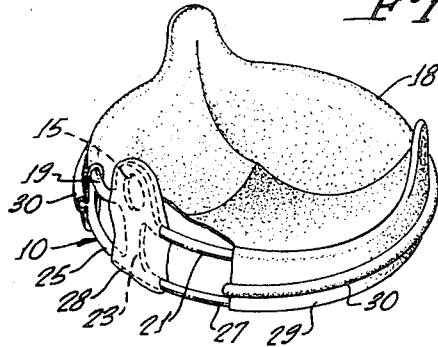

FIG. 2.

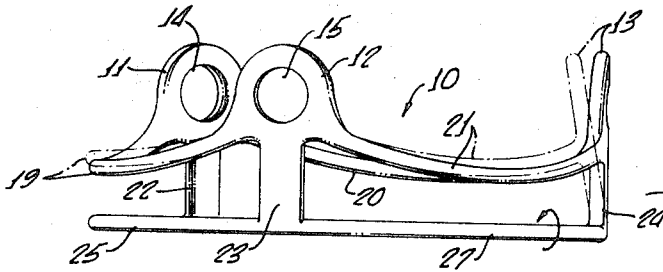
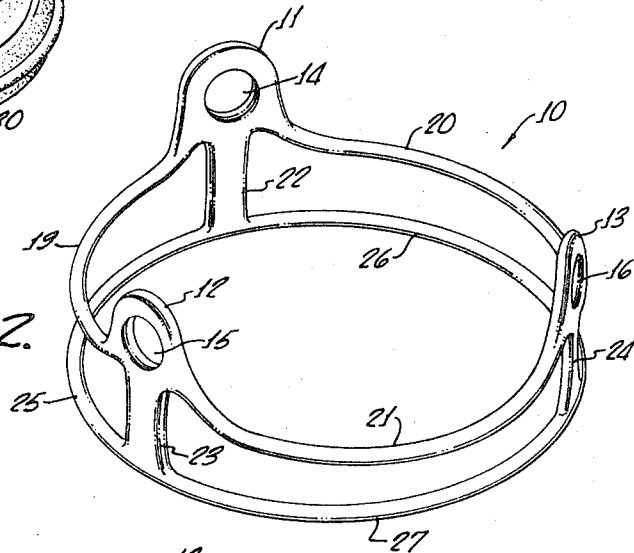

FIG. 3.

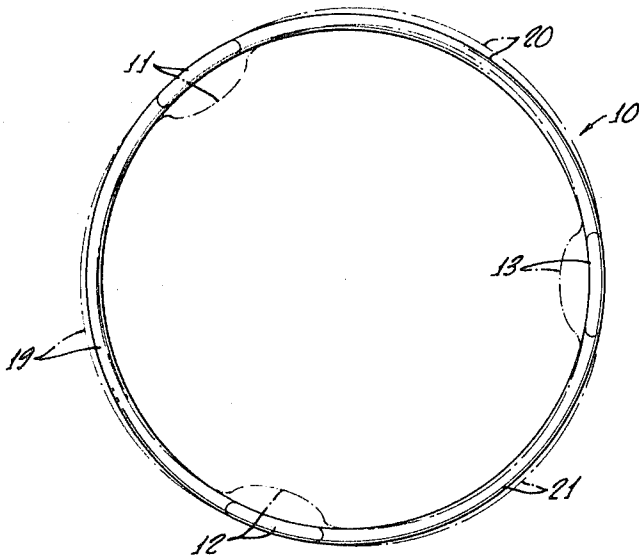

FIG. 4.

INVENTOR
WARREN D. HANCOCK
BY *James W. Carr*
Robert Rosenberg
ATTORNEYS.

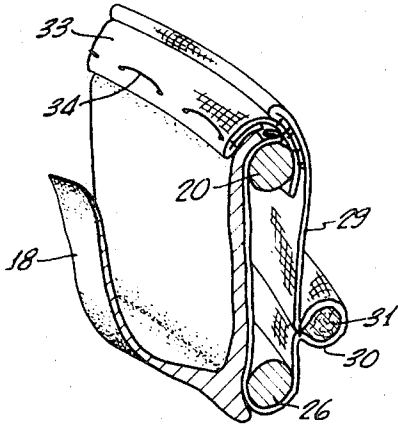

FIG. 5.

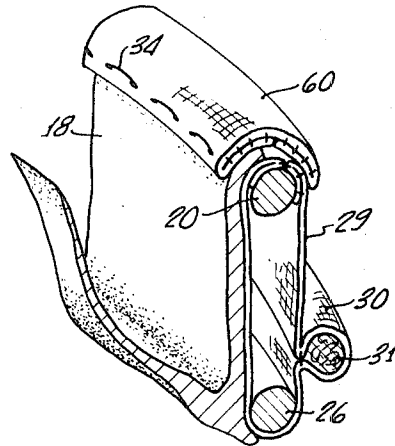

FIG. 10.

FIG. 11.

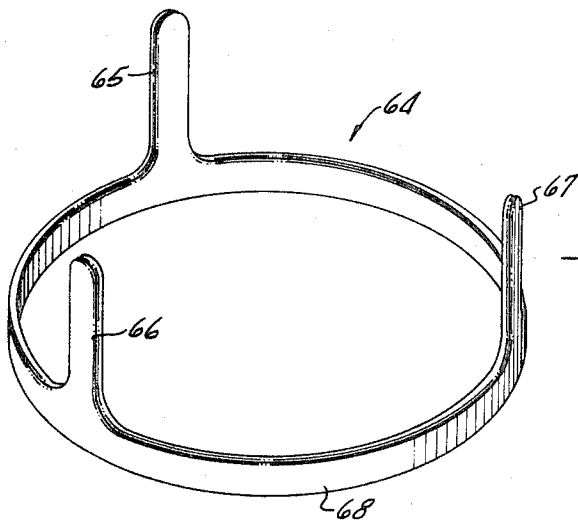
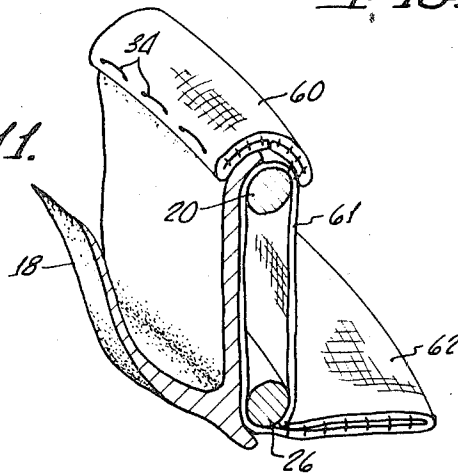

FIG. 12.

INVENTOR.
WARREN D. HANCOCK
BY *Janswitz, Carr
& Rothberg*
ATTORNEYS.

FIG. 6.

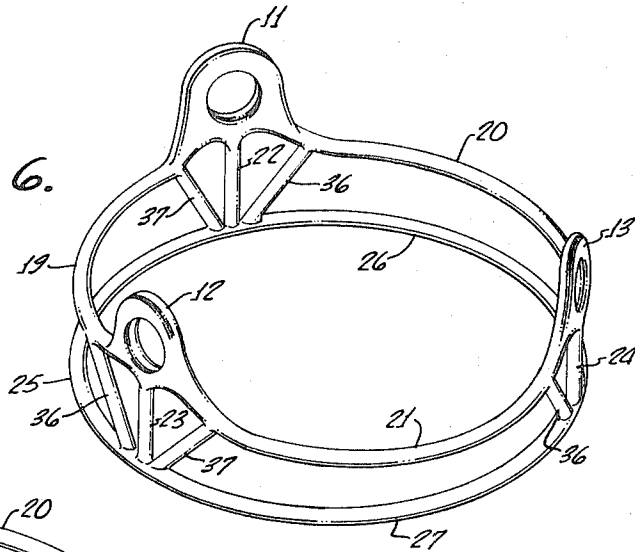

FIG. 7.

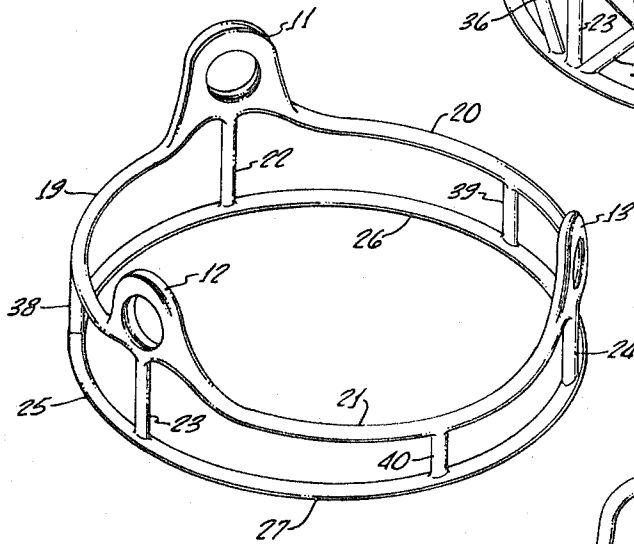

FIG. 8.

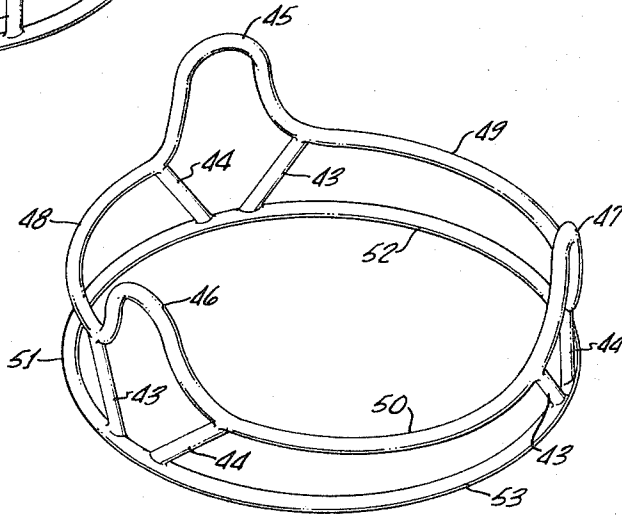
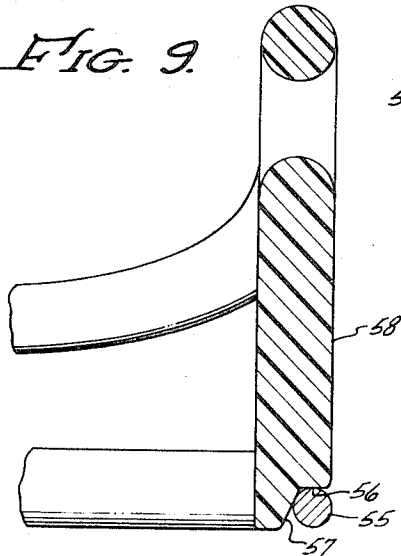

FIG. 9.



INVENTOR,
WARREN D. HANCOCK
BY *Jancowitz, Carr
& Rothberg*
ATTORNEYS.

FLEXIBLE STENT FOR HEART VALVE

BACKGROUND OF THE INVENTION

1. Field of the Invention

This invention relates to a supporting framework, or stent, for a natural or synthetic heart valve.

2. Description of Prior Art

It has been established that a stent is a useful arrangement for supporting a natural or synthetic heart valve for implantation in the human heart. The design shown in U.S. Pat. No. 3,570,014 offers advantages in properly supporting the valve and permitting its advance preparation for storage until the requirement for use arises. There has remained, however, room for improvement, particularly in assuring the reliability of the valve and its proper functioning over a long period of time. Malfunctioning of the valve may be caused by overstressing the valve tissue by the hemodynamic pressure imposed upon it when in use. Further areas of continued problems involve the fixing of the valve in the heart so as to provide a bed for ingrowth or attachment of tissue and a hemodynamic seal while avoiding clotting.

SUMMARY OF THE INVENTION

The present invention provides an improved arrangement for supporting a natural or synthetic heart valve in which the reliability of the valve is significantly improved. The invention contemplates the use of a stent which may bear a resemblance in appearance to that of the aforementioned U.S. Pat. No. 3,570,014. It includes three spaced apexes to support the valve commissures, with arms interconnecting the apexes. However, unlike the stent of that patent and other previous designs, the stent of the present invention is resilient. This allows deflection of the three apexes of the stent when the valve is subject to hemodynamic pressure during diastole. As the apexes are resiliently bent inwardly toward the axis of the stent, the stress in the tissue of the heart valve is correspondingly reduced. The result is a major improvement in the reliability of the valve, with an attendant reduction in danger to the life of the patient. The stent returns to its normal full diameter when the pressure is relieved, so that there is no undue restriction when the valve is in the open position.

The stent is arranged so that the arms remote from the apexes act as torsion bars as the deflection takes place, while the apexes themselves experience little distortion. Various arrangements may be included to stiffen the bars as may be required to obtain the proper degree of resiliency in the stent. The stiffening arrangements may include additional elements interconnecting the upper and lower bars of the stent.

A noncorrosive metal, such as stainless steel, may be used in constructing the stent, or it may be made of plastic. In either event, it is preferable that it be possible to deflect the arms permanently in order to vary the lateral dimensions of the stent so that it can be adjusted to fit a particular heart valve to be applied to it. This may be accomplished by exceeding the yield point of the metal stent, or through the use of heat or solvents in bending the plastic. In either event, however, the stent retains its resiliency after the adjustment.

For a plastic stent, a reinforcing ring may be provided at the exterior of the end of the stent remote from the

a frustoconical inner wall which assures that the ring does not interfere with the flexing of the stent from the pressures on the heart valve.

Improved means also may be included for more readily attaching the tissue to the stent and providing a matrix for ingrowth and subsequent fixation of the donor valve by the host tissue. This may include a cloth sleeve around the stent entirely covering it, together with an annular ring of cloth or sponge on the exterior of the unit at the end of the apexes extending over the marginal edge of the heart valve. The sutures for attaching the heart valve to the stent pass through the cloth ring as well, which reinforces the loops of the sutures so that they do not tend to cut through the tissue of the valve. Felt packing is included at apexes beneath the cloth sleeve to protect the cloth and sutures from abrading through contact with the stent.

The cloth sleeve around the stent may be provided with a bead intermediate the upper and lower arms, which also facilitates attachment to the heart and the ingrowth of tissue. When used in the mitral position, there is a projecting flat ring of cloth provided at the end of the stent opposite the apexes. This provides a means for suturing the valve assembly in the heart, resulting in a hemodynamic seal and a suitable bed over which tissue can be affixed or ingrown upon the grafting of the heart valve assembly.

BRIEF DESCRIPTION OF THE DRAWINGS:

FIG. 1 is a perspective view, partially broken away, illustrating a heart valve mounted on a stent in accordance with this invention;

FIG. 2 is an enlarged perspective view of the stent;

FIG. 3 is a side elevational view of the stent, illustrating the manner in which the stent deflects under load;

FIG. 4 is a top plan view of the arrangement of FIG. 3;

FIG. 5 is an enlarged fragmentary perspective view showing the attachment of the heart valve and cloth elements to the stent;

FIG. 6 is a perspective view of a stent having additional members for controlling the deflection of the upper arms;

FIG. 7 is a perspective view of a stent having a different arrangement of the members to control the deflection of the upper arms;

FIG. 8 is a perspective view of a modified form of the stent also controlling the deflection of the upper arms;

FIG. 9 is an enlarged fragmentary sectional view illustrating the arrangement for reinforcing the base of the stent when made from plastic;

FIG. 10 is a view similar to FIG. 5, but with a different arrangement of the cloth covering elements;

FIG. 11 is a view similar to FIGS. 5 and 10, but with the addition of a flap at the base of the stent for attachment to the heart; and

FIG. 12 is a perspective view of a stent of a different configuration.

DESCRIPTION OF THE PREFERRED EMBODIMENTS

The stent 10 illustrated in FIGS. 1-4 is of a basic shape for use in the aortic, mitral, tricuspid or pulmonary location. The stent 10 is an annular framework, circular in plan, made of a material which is both non-corrosive and resilient. Suitably, it may be constructed

Explore Litigation Insights

Docket Alarm provides insights to develop a more informed litigation strategy and the peace of mind of knowing you're on top of things.

Real-Time Litigation Alerts



Keep your litigation team up-to-date with **real-time alerts** and advanced team management tools built for the enterprise, all while greatly reducing PACER spend.

Our comprehensive service means we can handle Federal, State, and Administrative courts across the country.

Advanced Docket Research



With over 230 million records, Docket Alarm's cloud-native docket research platform finds what other services can't. Coverage includes Federal, State, plus PTAB, TTAB, ITC and NLRB decisions, all in one place.

Identify arguments that have been successful in the past with full text, pinpoint searching. Link to case law cited within any court document via Fastcase.

Analytics At Your Fingertips



Learn what happened the last time a particular judge, opposing counsel or company faced cases similar to yours.

Advanced out-of-the-box PTAB and TTAB analytics are always at your fingertips.

API

Docket Alarm offers a powerful API (application programming interface) to developers that want to integrate case filings into their apps.

LAW FIRMS

Build custom dashboards for your attorneys and clients with live data direct from the court.

Automate many repetitive legal tasks like conflict checks, document management, and marketing.

FINANCIAL INSTITUTIONS

Litigation and bankruptcy checks for companies and debtors.

E-DISCOVERY AND LEGAL VENDORS

Sync your system to PACER to automate legal marketing.