



US006621799B1

(12) **United States Patent**
Kemp et al.

(10) **Patent No.:** **US 6,621,799 B1**
(45) **Date of Patent:** **Sep. 16, 2003**

(54) **SEMI-RELIABLE DATA TRANSPORT**

(75) Inventors: **Bradford H. Kemp**, Salem, NH (US);
Benjamin E. McCann, Acton, MA (US)

(73) Assignee: **Enterasys Networks, Inc.**, Andover, MA (US)

(*) Notice: Subject to any disclaimer, the term of this patent is extended or adjusted under 35 U.S.C. 154(b) by 0 days.

(21) Appl. No.: **09/167,097**

(22) Filed: **Oct. 5, 1998**

(51) **Int. Cl.**⁷ **H04B 1/44**

(52) **U.S. Cl.** **370/282; 370/236; 709/237**

(58) **Field of Search** **709/203, 224, 709/230, 235, 237; 714/748; 380/212; 370/469, 236, 235, 216, 230, 229, 394, 389, 231, 248, 282**

(56) **References Cited**

U.S. PATENT DOCUMENTS

| | | | |
|----------------|--------|-----------------|---------|
| 5,553,083 A | 9/1996 | Miller | 714/748 |
| 5,745,685 A * | 4/1998 | Kirchner et al. | 709/237 |
| 6,076,114 A * | 6/2000 | Wesley | 709/235 |
| 6,105,064 A * | 8/2000 | Davis et al. | 709/224 |
| 6,273,622 B1 * | 8/2001 | Ben-David | 709/230 |

OTHER PUBLICATIONS

- Braden, R., "TCP Extensions for High Performance: An Update", Jun. 21, 1993.
- Brakmo et al., "TCP Vegas: New Techniques for Congestion Detection and Avoidance", Dept. of Computer Science, University of Arizona, Tucson, AZ, 1996.
- Brakmo et al., "TCP Vegas: End to End Congestion Avoidance on a Global Internet", Dept. of Computer Science, University of Arizona, Tucson, AZ.
- Brakmo et al., "Performance Problems in BSD4.4 TCP", Dept. of Computer Science, University of Arizona, Tucson, AZ.

Fall et al., "Comparisons of Tahoe, Reno, and Sack TCP", Lawrence Berkeley National Laboratory, Berkeley, CA, Dec. 2, 1995.

Floyd, S., "TCP and Successive Fast Retransmits" Lawrence Berkeley Laboratory, Berkeley, CA, May 1995.

Floyd et al., "Increasing TCP's Initial Window", Jul. 1997.

Floyd S., "Issues of TCP with SACK", Mar. 9, 1996.

Hanks, S., "Generic Routing Encapsulation (GRE)", Oct. 1994.

Jacobson, V., "Re: interpacket arrival variance and mean", e-mail message, Jun. 15, 1987.

Jacobson, V., "Re: your congestion scheme", e-mail message, Nov. 1987.

(List continued on next page.)

Primary Examiner—Hassan Kizou

Assistant Examiner—John Pezzlo

(74) *Attorney, Agent, or Firm*—Fish & Richardson P.C.

(57) **ABSTRACT**

A new type of communication protocol provides semi-reliable transport of data over a data channel, such as over the Internet. The new type of protocol limits the number of retransmissions of unsuccessfully delivered data and may eventually "give up" on successfully delivering particular data and go on sending subsequent data to the destination. When a reliable communication protocol, such as TCP/IP is tunneled between two computers over a virtual connection which uses the new type of semi-reliable protocol, overall error control of data passing between the two computers involves elements of error control implemented by both the semi-reliable protocol and the reliable protocol. This overall error control can provide higher throughput than provided by using either a completely reliable protocol (e.g., TCP) for the virtual connection, or a completely unreliable protocol (e.g., UDP) for the virtual connection. This advantage can be even more pronounced if the data stream is compressed or encrypted before being passed over the virtual connection using a technique which maintains state from one data packet to another.

25 Claims, 14 Drawing Sheets

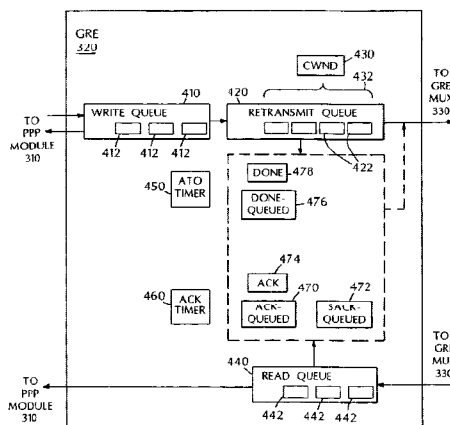

OTHER PUBLICATIONS

- Jacobson, V., "Dynamic Congestion Avoidance/Control", e-mail message, Feb. 1988.
- Jacobson, V., "TCP Extensions for Long Delay Paths", Oct. 1988.
- Jacobson, V., "Modified TCP Congestion Avoidance Algorithm", e-mail message, Apr. 1990.
- Jacobson, V., "Design Changes to the Kernel Network Architecture for 4.4BSD", Lawrence Berkeley Laboratory, Berkeley, CA May 1992.
- Jacobson, V., "Some Design Issues for High-Speed Networks", Lawrence Berkeley Laboratory, Berkeley, CA Nov. 1993.
- Jacobson, V., "End2End", e-mail message, Mar. 1994.
- Jacobson, V., "TCP Extensions for High Performance", e-mail message, Feb. 1997.
- Mathis et al., "Forward Acknowledgement: Refining TCP Congestion Control", Pittsburgh Supercomputing Center.
- Mathis et al., "TCP Rate-Halving with Bounding Parameters", Pittsburgh Supercomputing Center, Oct. 1996.
- Mathis et al., "TCP Rate-Halving with Bounding Parameters", Pittsburgh Supercomputing Center, Oct. 1996.
- Mathis et al., "TCP Selective Acknowledgement Options", e-mail message, Oct. 1996.
- Meyer, G., "The PPP Encryption Control Protocol (ECP)", Spider Systems, e-mail message, Jun. 1996.
- Partridge et al., "A Faster UDP", IEEE/ACM Trans. on Networking, Aug. 1993.
- Rand, D., "The PPP Compression Control Protocol (CCP)", Novell, e-mail message, Jun. 1996.
- Rizzo, L., "Issues in the implementation of selective acknowledgements for TCP", e-mail message, Jan. 1996.
- Sharma et al., "Scalable Timers for Soft State Protocols", Information Sciences Institute, University of Southern California.
- Simpson, W., "The Point-to-Point Protocol (PPP)", Daydreamer, Jul. 1994.
- Stevens, W., "TCP Slow Start, Congestion Avoidance, Fast Retransmit, and Fast Recovery Algorithms", NOAO, Jan. 1997.
- TCP Selective Acknowledgement option (and related changes) for FreeBSD, Sep. 1997.
- Network Working Group Request for Comments: 1072, "TCP Extensions for Long-Delay Paths", Sep. 1997.
- Ideal Congestion Control, Sep. 1997.
- Marasli et al., "Partially Reliable Transport Service", *Proceedings, Second IEEE Symposium on Computers and Communications (Cat. No. 97TB100137), Proceedings Second IEEE Symposium on Computer and Communications, Alexandria, Egypt*, Jul. 1-3, 1997, pp. 648-656.
- Marasli et al., "Retransmission-Based Partially Reliable Transport Service: An Analytic Model", *Proceedings of Infocom, US, Los Alamitos, IEEE Comp. Soc. Press*, vol. Conf. 15, 1996, pp. 621-629.

* cited by examiner

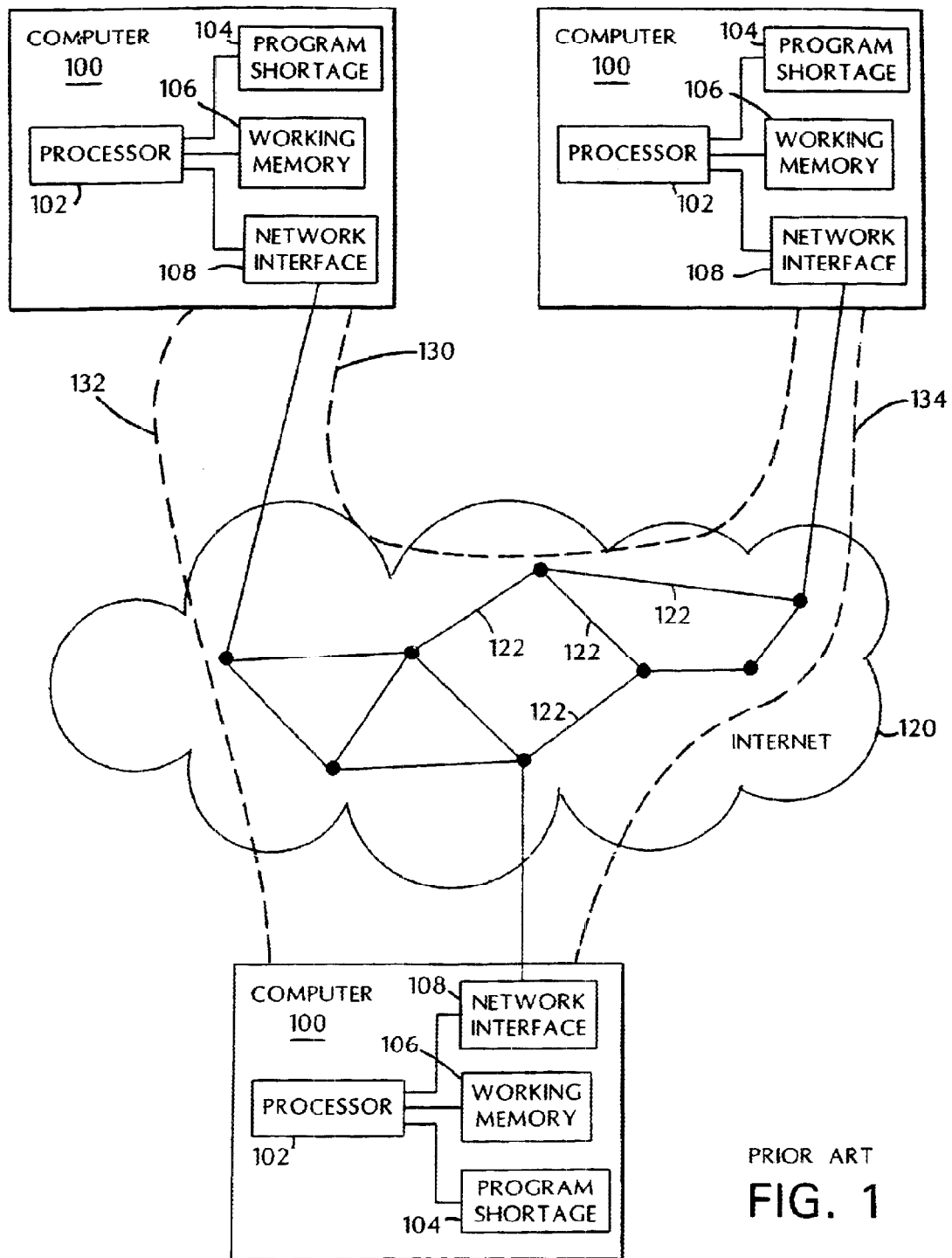

PRIOR ART
FIG. 1

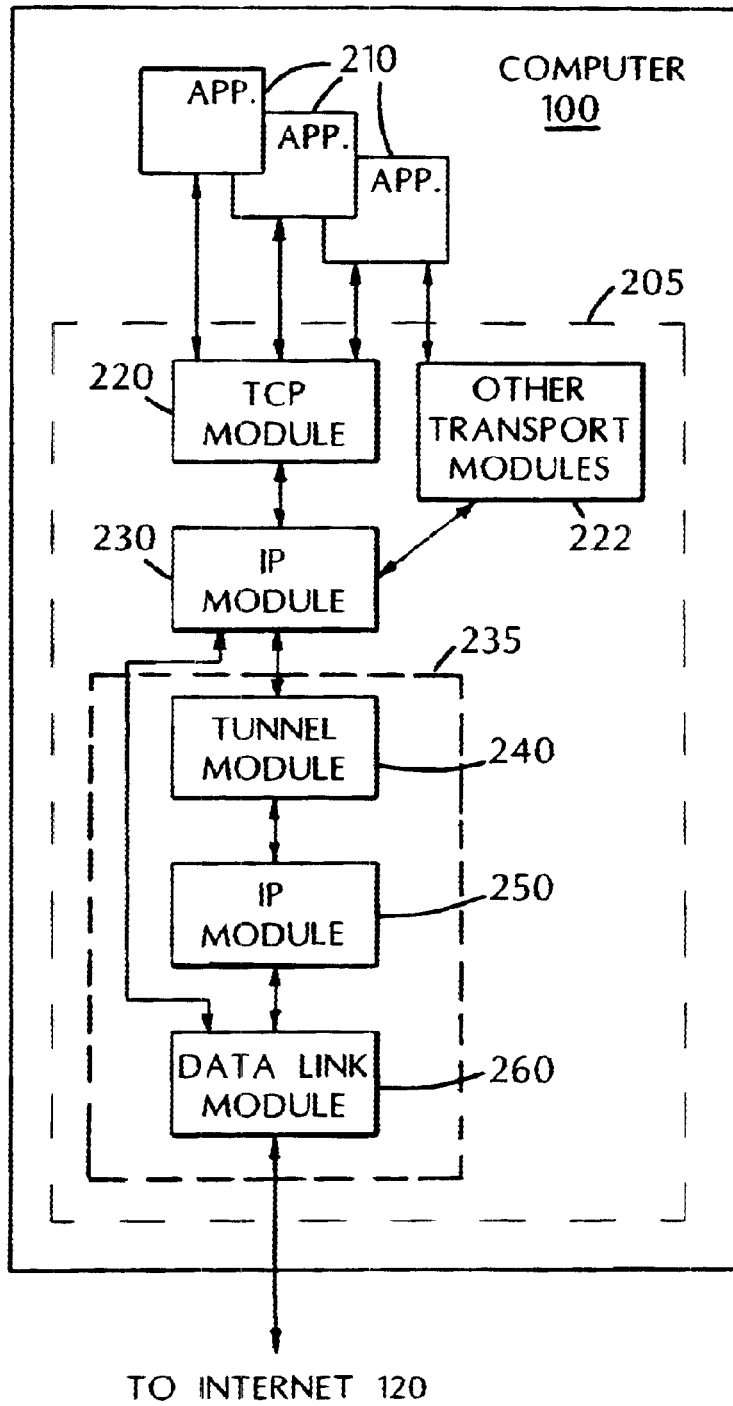

PRIOR ART
FIG. 2

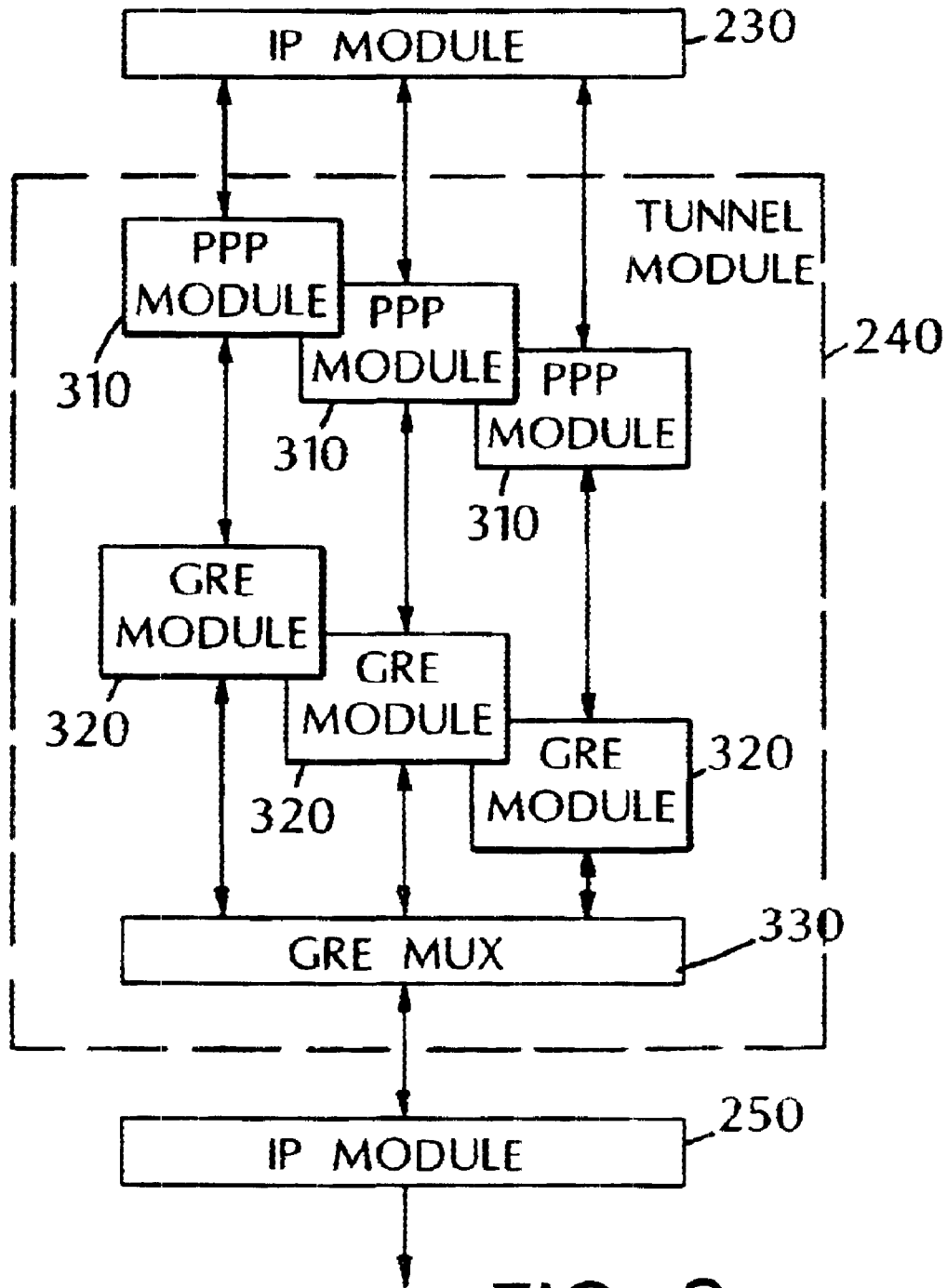

FIG. 3

Explore Litigation Insights

Docket Alarm provides insights to develop a more informed litigation strategy and the peace of mind of knowing you're on top of things.

Real-Time Litigation Alerts



Keep your litigation team up-to-date with **real-time alerts** and advanced team management tools built for the enterprise, all while greatly reducing PACER spend.

Our comprehensive service means we can handle Federal, State, and Administrative courts across the country.

Advanced Docket Research



With over 230 million records, Docket Alarm's cloud-native docket research platform finds what other services can't. Coverage includes Federal, State, plus PTAB, TTAB, ITC and NLRB decisions, all in one place.

Identify arguments that have been successful in the past with full text, pinpoint searching. Link to case law cited within any court document via Fastcase.

Analytics At Your Fingertips



Learn what happened the last time a particular judge, opposing counsel or company faced cases similar to yours.

Advanced out-of-the-box PTAB and TTAB analytics are always at your fingertips.

API

Docket Alarm offers a powerful API (application programming interface) to developers that want to integrate case filings into their apps.

LAW FIRMS

Build custom dashboards for your attorneys and clients with live data direct from the court.

Automate many repetitive legal tasks like conflict checks, document management, and marketing.

FINANCIAL INSTITUTIONS

Litigation and bankruptcy checks for companies and debtors.

E-DISCOVERY AND LEGAL VENDORS

Sync your system to PACER to automate legal marketing.