



US005083562A

**United States Patent** [19]  
**de Coriolis et al.**

[11] **Patent Number:** 5,083,562  
[45] **Date of Patent:** Jan. 28, 1992

- [54] **METHOD AND APPARATUS FOR APPLYING ASYMMETRIC BIPHASIC TRUNCATED EXPONENTIAL COUNTERSHOCKS**
- [75] **Inventors:** Paul E. de Coriolis; John R. Batty, Jr., both of Miami, Fla.; Bruce J. Shook, North Andover, Mass.
- [73] **Assignee:** Teletronics Pacing Systems, Inc., Englewood, Colo.
- [21] **Appl. No.:** 574,510
- [22] **Filed:** Aug. 28, 1990

**Related U.S. Application Data**

- [63] Continuation of Ser. No. 397,637, Aug. 23, 1989, abandoned, which is a continuation of Ser. No. 145,515, Jan. 19, 1988, abandoned.

- [51] **Int. Cl.<sup>5</sup>** ..... A61N 1/36
- [52] **U.S. Cl.** ..... 128/419 D
- [58] **Field of Search** ..... 128/419 D

**References Cited**

**U.S. PATENT DOCUMENTS**

3,224,447	12/1965	Becker et al.	128/421
3,614,955	10/1971	Mirowski et al.	128/419 D
4,120,305	10/1978	Rhoads et al.	128/405
4,498,478	2/1985	Bourgeois	128/419 PG
4,576,170	3/1986	Bradley et al.	128/419 D
4,637,397	1/1987	Jones et al.	128/419 D
4,800,883	1/1989	Winstrom	128/419 D
4,821,723	4/1989	Baker, Jr. et al.	128/419 D
4,830,006	5/1989	Haluska et al.	128/419 PG
4,850,357	7/1989	Bach, Jr.	128/419 D
4,953,551	9/1990	Mehra et al.	128/419 D

**FOREIGN PATENT DOCUMENTS**

0281219 9/1988 European Pat. Off. .

**OTHER PUBLICATIONS**

- W. B. Kouwenhoven, *Annals of Internal Medicine*, vol. 71, No. 3, pp. 449-458 (Sep., 1969).
- Langer et al., "Considerations in the Development of the Automatic Implantable Defibrillator," *Medical In-*

- strumentation*: vol. 10, No. 3; May-Jun. 1976; pp. 163-167.
- Mirowski et al., "Termination of Malignant Ventricular Arrhythmias with an Implanted Automatic Defibrillator in Human Beings," *New Eng. Journal of Med.*; 8/7/80; pp. 322-324.
- Mirowski et al., "Clinical Treatment of Life-Threatening Ventricular Tachyarrhythmias with the Automatic Implantable Defibrillator," *Amer. Heart Journal*; 8/81, pp. 265-270.
- Schuder et al., "Waveform Dependency in Defibrillating 100 kg Calves," *Devices & Tech. Meeting, NIH*, 1982; p. 174.
- J. L. Jones & R. E. Jones, "Defibrillator Waveshape Optimization," *Devices & Tech. Meeting, NIH*, 1982; p. 175.
- J. L. Jones & R. E. Jones, "Improved Defibrillator Waveform Safety Factor with Biphasic Waveforms," *The American Journal of Physiology*, 7/83; 245:1; pp. H60-H65.
- Schuder et al., "Ultrahigh-Energy Hydrogen Thyatron/SCR Bidirectional Waveform Defibrillator," *Medical & Biological Engineering & Computing*, Jul. 1982, pp. 419-424.
- R. A. Winkle, "The Implantable Defibrillator in Ventricular Arrhythmias," *Hospital Practice*, Mar. 1983, pp. 149-165.

(List continued on next page.)

*Primary Examiner*—Francis Jaworski  
*Attorney, Agent, or Firm*—Gottlieb, Rackman & Reisman

**[57] ABSTRACT**

A method and apparatus for applying an asymmetric biphasic exponential waveform countershock to the heart useful in an implantable cardioverter or defibrillator, wherein the second phase has a start amplitude of substantially one half that of the first phase, and wherein the polarity of a capacitor discharging through a current path including the heart is reversed. A voltage reversing circuit may include a voltage shifter which shifts voltage associated with switching elements in the circuit to reduce voltage stresses in the switching elements.

**18 Claims, 4 Drawing Sheets**

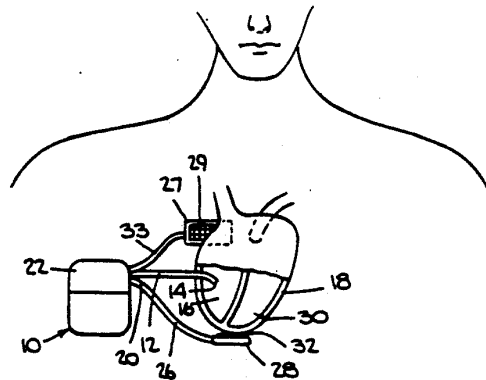

## OTHER PUBLICATIONS

- Schuder et al., "Transthoracic Ventricular Defibrillation in the 100 kg Calf with Symmetrical One-Cycle Bidirectional Rectangular Wave Stimuli," *IEEE Transactions on Biomedical Engineering*, vol. BME-30, No. 7; Jul. 1983; pp. 415-422.
- Schuder et al., "Defibrillation of 100 kg Calves with Asymmetrical, Bidirectional, Rectangular Pulses," *Cardiovascular Research*; 1984:18; pp. 419-426.
- Schuder et al., "One-Cycle Bidirectional Rectangular Wave Shocks for Open Chest Defibrillation in the Calf," *Abs. Amer. Soc. Artificial Internal Organs*; 9:16.
- Schuder et al., "Development of Automatic Implanted Defibrillator," *Devices & Tech. Meeting, NIH*; p. 206 (1981).
- Tang et al., "Ventricular Defibrillation Using Biphasic Waveforms of Different Phasic Duration," *PACE*: vol. 10; Mar.-Apr. 1987.
- Tang et al., "Strength Duration Curve for Ventricular Defibrillation Using Biphasic Waveforms," *The North Amer. Society of Pacing and Electrophysiology*; May 2, 1987; p. 49.
- Winkle et al., "Improved Low Energy Defibrillation Efficacy in Man Using a Biphasic Truncated Exponential Waveform," *JACC*; vol. 9, No. 2; Feb. 1987; p. 142A.
- B. D. Lindsay et al., "Prospective Evaluation of a Sequential Pacing and High-Energy Bidirectional Shock Algorithm for Transvenous Cardioversion in Patients with Ventricular Tachycardia," *Therapy and Prevention*, vol. 76, No. 3 (Sep., 1987).
- S. Saksena et al., "A Prospective Evaluation of Single and Dual Current Pathways for Transvenous Cardioversion in Rapid Ventricular Tachycardia," *PACE*, vol. 10, pp. 1130-1141 (Sep.-Oct., 1987).
- S. Saksena et al., "Developments for Future Implantable Cardioverters and Defibrillators," *PACE*, vol. 10, pp. 1342-1358 (Nov.-Dec., 1987).

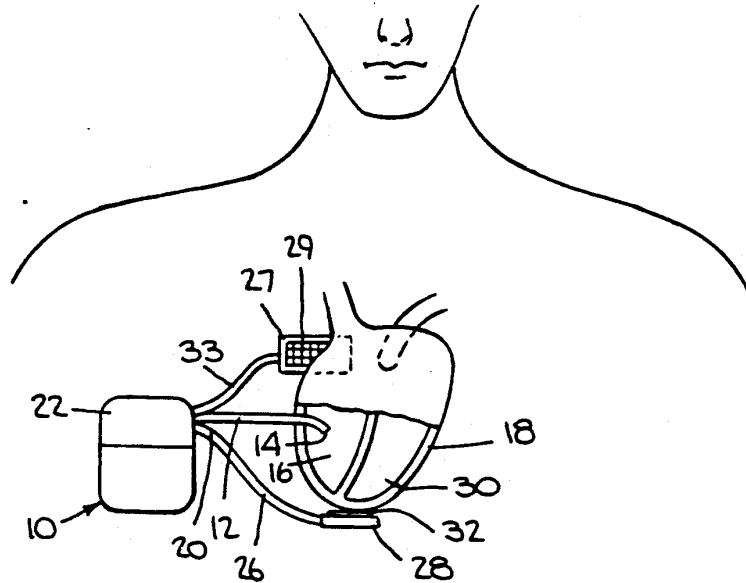

Fig. 1.

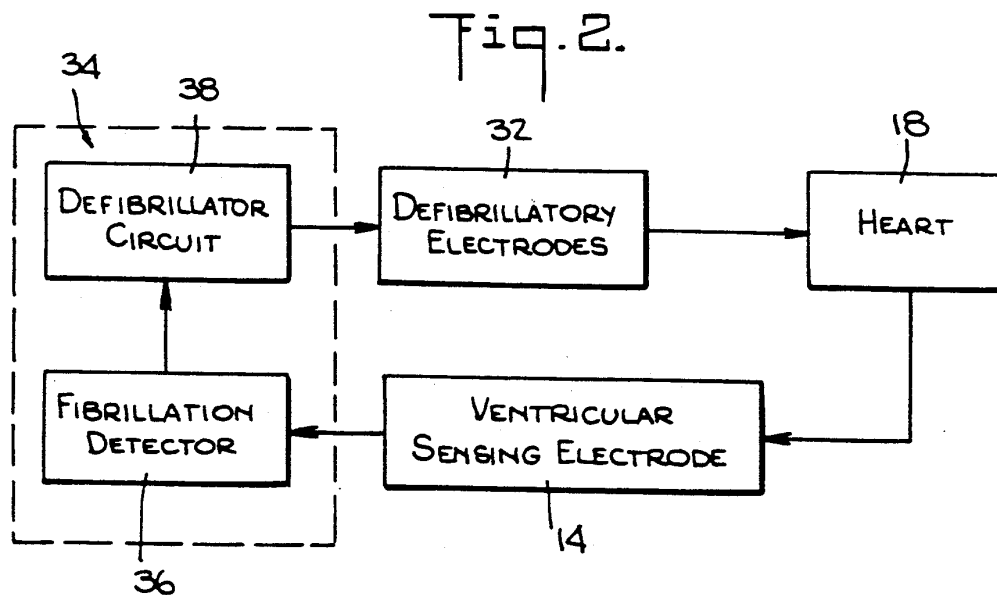
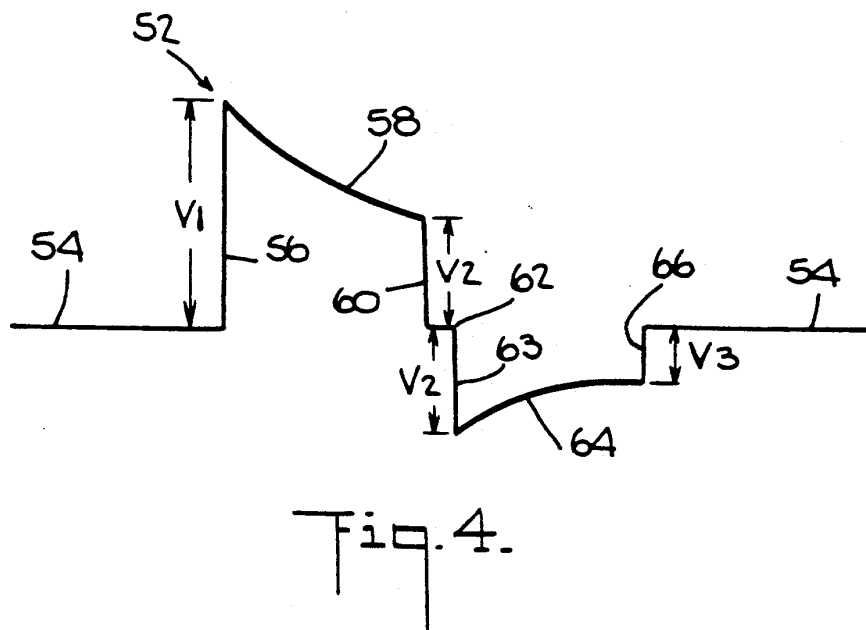
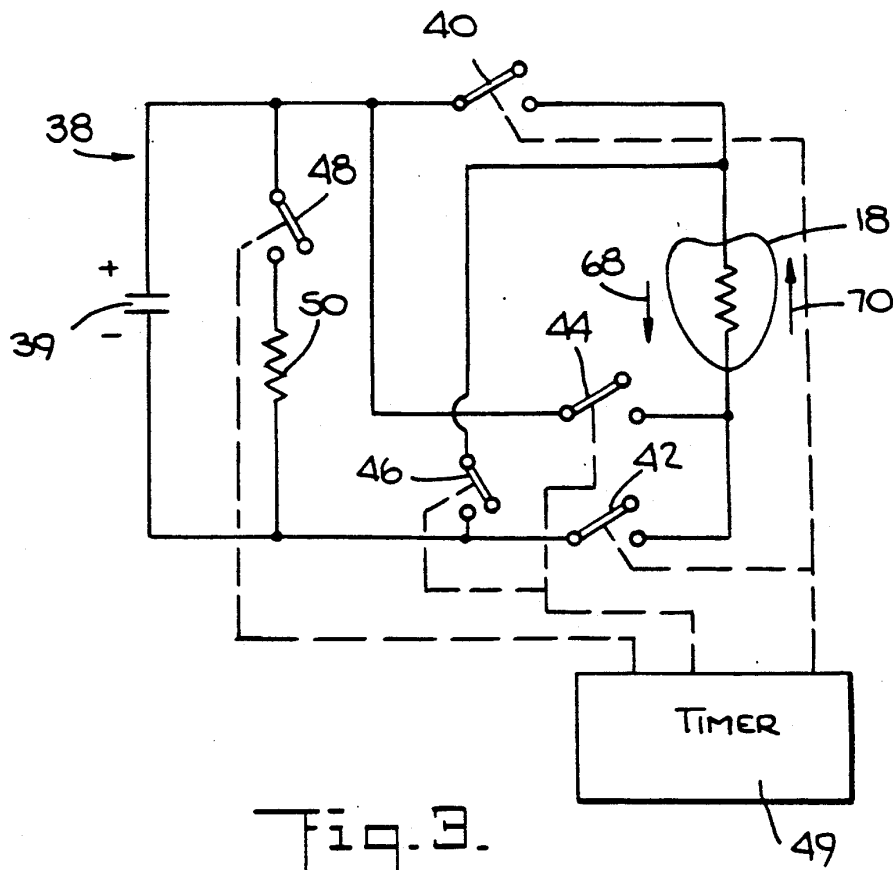

Fig. 2.



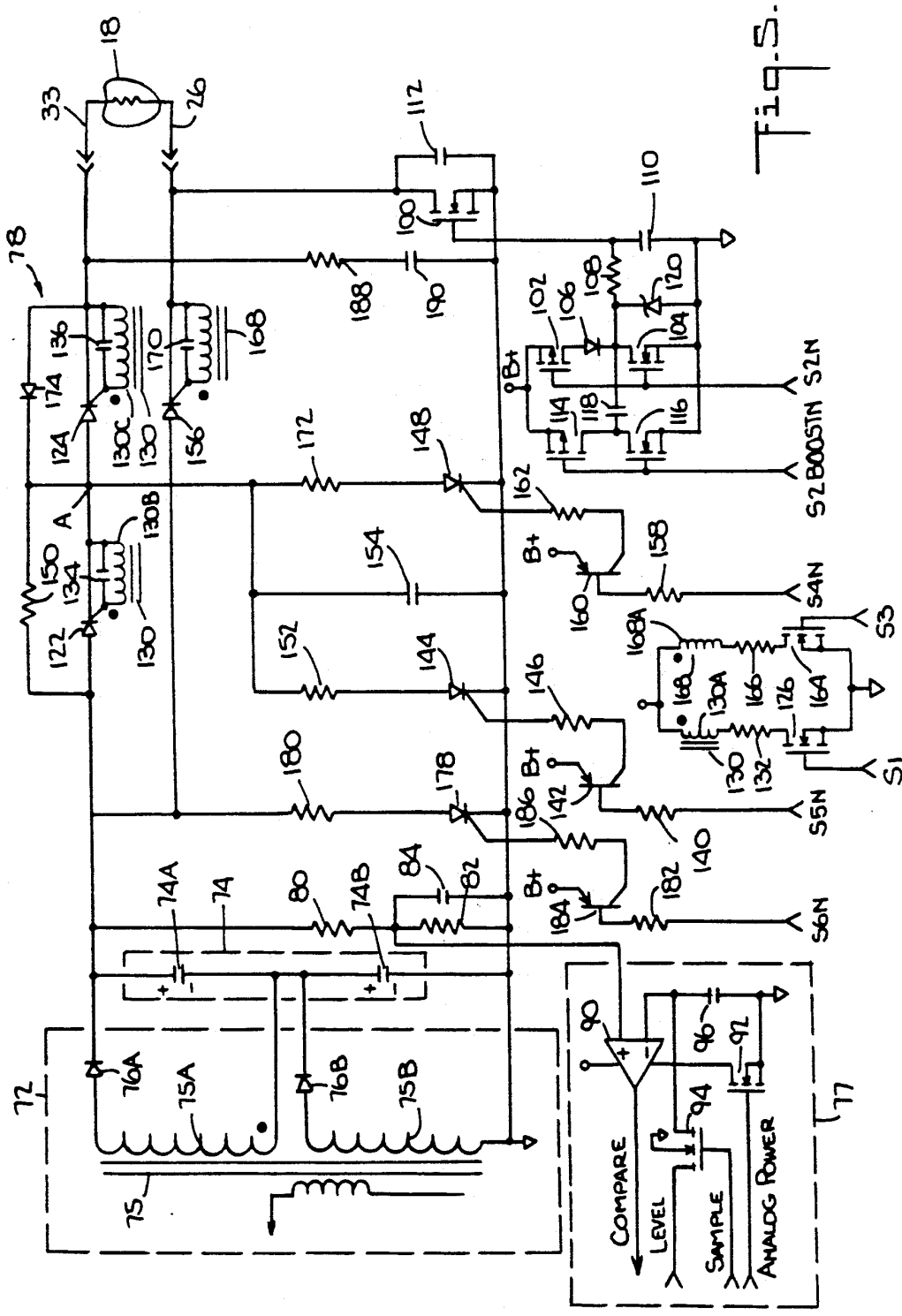

Fig. 5.

# Explore Litigation Insights

Docket Alarm provides insights to develop a more informed litigation strategy and the peace of mind of knowing you're on top of things.

## Real-Time Litigation Alerts



Keep your litigation team up-to-date with **real-time alerts** and advanced team management tools built for the enterprise, all while greatly reducing PACER spend.

Our comprehensive service means we can handle Federal, State, and Administrative courts across the country.

## Advanced Docket Research



With over 230 million records, Docket Alarm's cloud-native docket research platform finds what other services can't. Coverage includes Federal, State, plus PTAB, TTAB, ITC and NLRB decisions, all in one place.

Identify arguments that have been successful in the past with full text, pinpoint searching. Link to case law cited within any court document via Fastcase.

## Analytics At Your Fingertips



Learn what happened the last time a particular judge, opposing counsel or company faced cases similar to yours.

Advanced out-of-the-box PTAB and TTAB analytics are always at your fingertips.

## API

Docket Alarm offers a powerful API (application programming interface) to developers that want to integrate case filings into their apps.

## LAW FIRMS

Build custom dashboards for your attorneys and clients with live data direct from the court.

Automate many repetitive legal tasks like conflict checks, document management, and marketing.

## FINANCIAL INSTITUTIONS

Litigation and bankruptcy checks for companies and debtors.

## E-DISCOVERY AND LEGAL VENDORS

Sync your system to PACER to automate legal marketing.