



US005607454A

**United States Patent** [19]  
**Cameron et al.**

[11] **Patent Number:** **5,607,454**  
[45] **Date of Patent:** **Mar. 4, 1997**

[54] **ELECTROTHERAPY METHOD AND APPARATUS**

WO94/21327 9/1994 WIPO .  
WO94/22530 10/1994 WIPO .

[75] Inventors: **David Cameron**, Seattle; **Thomas D. Lyster**, Bothell; **Daniel J. Powers**, Bainbridge Island; **Bradford E. Gliner**, Bellevue; **Clinton S. Cole**, Seattle; **Carlton B. Morgan**, Bainbridge Island, all of Wash.

**OTHER PUBLICATIONS**

Alferness et al., "The influence of shock waveforms on defibrillation efficacy," *IEEE Engineering in Medicine and Biology*, pp. 25-27 (Jun. 1990).  
Anderson et al., "The efficacy of trapezoidal wave forms for ventricular defibrillation," *Chest*, 70(2):298-300 (1976).  
Blilie et al., "Predicting and validating cardiothoracic current flow using finite element modeling," *PACE*, 15:563, abstract 219 (Apr. 1992).

[73] Assignee: **Heartstream, Inc.**, Seattle, Wash.

(List continued on next page.)

[21] Appl. No.: **227,553**

[22] Filed: **Apr. 14, 1994**

**Related U.S. Application Data**

[63] Continuation-in-part of Ser. No. 103,837, Aug. 6, 1993.

[51] **Int. Cl.<sup>6</sup>** ..... **A61N 1/39**

[52] **U.S. Cl.** ..... **607/5; 607/7; 607/6; 607/74; 607/62**

[58] **Field of Search** ..... **607/2, 4, 5-7, 607/62, 74**

[56] **References Cited**

**U.S. PATENT DOCUMENTS**

3,211,154 10/1965 Becker et al. .  
3,241,555 3/1966 Caywood et al. .  
3,706,313 12/1972 Milani et al. .  
3,782,389 1/1974 Bell ..... 607/8  
3,860,009 1/1975 Bell et al. .... 607/8  
3,862,636 1/1975 Bell et al. .... 607/5  
3,886,950 6/1975 Ukkestad et al. .... 607/5

(List continued on next page.)

**FOREIGN PATENT DOCUMENTS**

0281219 9/1988 European Pat. Off. .  
0315368 5/1989 European Pat. Off. .  
0353341 2/1990 European Pat. Off. .  
0437104 7/1991 European Pat. Off. .  
0507504 10/1992 European Pat. Off. .  
2070435 9/1981 United Kingdom .  
2083363 3/1982 United Kingdom .  
WO93/16759 9/1993 WIPO .

*Primary Examiner*—Marvin M. Lateef  
*Assistant Examiner*—Kennedy J. Schaezle  
*Attorney, Agent, or Firm*—Morrison & Foerster

[57] **ABSTRACT**

An electrotherapy method and apparatus for delivering a multiphasic waveform from an energy source to a patient. The preferred embodiment of the method comprises the steps of charging the energy source to an initial level; discharging the energy source across the electrodes to deliver electrical energy to the patient in a multiphasic waveform; monitoring a patient-dependent electrical parameter during the discharging step; shaping the waveform of the delivered electrical energy based on a value of the monitored electrical parameter, wherein the relative duration of the phases of the multiphasic waveform is dependent on the value of the monitored electrical parameter. The preferred apparatus comprises an energy source; two electrodes adapted to make electrical contact with a patient; a connecting mechanism forming an electrical circuit with the energy source and the electrodes when the electrodes are attached to a patient; and a controller operating the connecting mechanism to deliver electrical energy from the energy source to the electrodes in a multiphasic waveform the relative phase durations of which are based on an electrical parameter monitored during delivery of the electrical energy. The preferred defibrillator apparatus weighs less than 4 pounds and has a volume less than 150 cubic inches, and most preferably, weighs approximately three pounds or less and has a volume of approximately 141 cu. in.

**59 Claims, 4 Drawing Sheets**

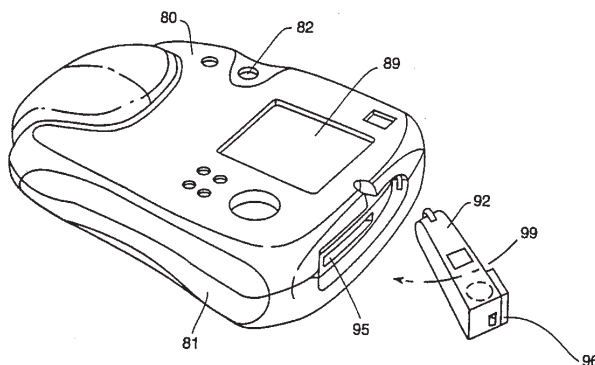

## U.S. PATENT DOCUMENTS

4,023,573	5/1977	Pantridge et al.	607/5
4,328,808	5/1982	Charbonnier et al.	
4,419,998	12/1983	Heath	
4,473,078	9/1984	Angel	607/6
4,494,552	1/1985	Heath	
4,504,773	3/1985	Suzuki et al.	
4,574,810	3/1986	Lerman	
4,595,009	6/1986	Leinders	
4,610,254	9/1986	Morgan et al.	
4,619,265	10/1986	Morgan et al.	
4,637,397	1/1987	Jones et al.	
4,745,923	5/1988	Winstrom	
4,800,883	1/1989	Winstrom	
4,821,723	4/1989	Baker, Jr. et al.	
4,840,177	6/1989	Charbonnier et al.	
4,848,345	7/1989	Zenkich	
4,850,357	7/1989	Bach, Jr.	
4,953,551	9/1990	Mehra et al.	
4,998,531	3/1991	Bocchi et al.	
5,078,134	1/1992	Heilman et al.	
5,083,562	1/1992	de Coriolis et al.	
5,107,834	4/1992	Ideker et al.	
5,111,813	5/1992	Charbonnier et al.	
5,111,816	5/1992	Pless et al.	
5,207,219	5/1993	Adams et al.	
5,215,081	6/1993	Ostroff	
5,222,480	6/1993	Couche et al.	
5,222,492	6/1993	Morgan et al.	
5,230,336	7/1993	Fain et al.	607/7
5,237,989	8/1993	Morgan et al.	
5,249,573	10/1993	Fincke et al.	607/6
5,275,157	1/1994	Morgan et al.	
5,306,291	4/1994	Kroll et al.	
5,334,219	8/1994	Kroll	
5,352,239	10/1994	Pless	607/5
5,370,664	12/1994	Morgan et al.	
5,372,606	12/1994	Lang et al.	607/8

## OTHER PUBLICATIONS

Chapman et al., "Non-thoracotomy internal defibrillation: Improved efficacy with biphasic shocks," *Circulation*, 76:312, abstract no. 1239 (1987).

Cooper et al., "Temporal separation of the two pulses of single capacitor biphasic and dual monophasic waveforms," *Circulation*, 84(4):612, abstract no. 2433 (1991).

Cooper et al., "The effect of phase separation on biphasic waveform defibrillation," *PACE*, 16:471-482 (Mar. 1993).

Cooper et al., "The effect of temporal separation of phases on biphasic waveform defibrillation efficacy," *The Annual International Conference of the IEEE Engineering in Medicine and Biology Society*, 13(2):0766-0767 (1991).

Crampton et al., "Low-energy ventricular defibrillation and miniature defibrillators," *JAMA*, 235(21):2284 (1976).

Dahlbäck et al., "Ventricular defibrillation with square-waves," *The Lancet* (Jul. 2, 1966).

Echt et al., "Biphasic waveform is more efficacious than monophasic waveform for transthoracic cardioversion," *PACE*, 16:914, abstract no. 256 (Apr. 1993).

Feeser et al., "Strength-duration and probability of success curves for defibrillation with biphasic waveforms," *Circulation*, 82(6):2128-2141 (1990).

Guse et al., "Defibrillation with low voltage using a left ventricular catheter and four cutaneous patch electrodes in dogs," *PACE*, 14:443-451 (Mar. 1991).

Jones et al., "Decreased defibrillator-induced dysfunction with biphasic rectangular waveforms," *Am. J. Physiol.*, 247:H792-796 (1984).

Jones et al., "Defibrillator waveshape optimization," Devices and Tech. Meeting, NIH (1982).

Jones et al., "Improved defibrillator waveform safety factor with biphasic waveforms," *Am. J. Physiol.*, 245:H60-65 (1983).

Jones et al., "Reduced excitation threshold in potassium depolarized myocardial cells with symmetrical biphasic waveforms," *J. Mol. Cell. Cardiol.*, 17(39):XXVII, abstract no. 39 (1985).

Jude et al., "Fundamentals of Cardiopulmonary Resuscitation," F.A. Davis Company, Philadelphia PA, pp. 98-104 (1965).

Kerber et al., "Energy, current, and success in defibrillation and cardioversion: Clinical studies using an automated impedance-based method of energy adjustment," *Circulation*, 77(5):1038-1046 (1988).

Knickerbocker et al., "A portable defibrillator," *IEEE Trans. on Power and Apparatus Systems*, 69:1089-1093 (1963).

Kouwenhoven, "The development of the defibrillator," *Annals of Internal Medicine*, 71(3):449-458 (1969).

Langer et al., "Considerations in the development of the automatic implantable defibrillator," *Medical Instrumentation*, 10(3):163-167 (1976).

Lerman et al., "Current-based versus energy-based ventricular defibrillation: A prospective study," *JACC*, 12(5):1259-1264 (1988).

Lindsay et al., "Prospective evaluation of a sequential pacing and high-energy bi-directional shock algorithm for transvenous cardioversion in patients with ventricular tachycardia," *Circulation*, 76(3):601-609 (1987).

Mirowski et al., "Clinical treatment of life threatening ventricular tachyarrhythmias with the automatic implantable defibrillator," *American Heart Journal*, 102(2):265-270 (1981).

Mirowski et al., "Termination of malignant ventricular arrhythmias with an implanted automatic defibrillator in human beings," *The New England Journal of Medicine*, 303(6):322-324 (1980).

Podolsky, "Keeping the beat alive," *U.S. News & World Report* (Jul. 22, 1991).

Product Brochure for First Medic Semi-Automatic Defibrillators (1994), Spacelabs Medical Products, 15220 N.E. 40th Street, P.O. Box 97013, Redmond, WA 98073-9713.

Product Brochure for the Shock Advisory System (1987), Physio-Control, 11811 Willows Road Northeast, P.O. Box 97006, Redmond, WA 98073-9706.

Redd (editor), "Defibrillation with biphasic waveform may increase safety, improve survival," *Medlines*, pp. 1-2 (Jun.-Jul. 1984).

Saksena et al., "A prospective evaluation of single and dual current pathways for transvenous cardioversion in rapid ventricular tachycardia," *PACE*, 10:1130-1141 (Sep.-Oct. 1987).

Saksena et al., "Developments for future implantable cardioverters and defibrillators," *PACE*, 10:1342-1358 (Nov.-Dec. 1987).

Schuder "The role of an engineering oriented medical research group in developing improved methods and devices for achieving ventricular defibrillation: The University of Missouri experience," *PACE*, 16:95-124 (Jan. 1993).

Schuder et al., "Comparison of effectiveness of relay-switched, one-cycle quasisinusoidal waveform with critically damped sinusoid waveform in transthoracic defibrillation of 100-kilogram calves," *Medical Instrumentation*, 22(6):281-285 (1988).

- Schuder et al., "A multielectrode-time sequential laboratory defibrillator for the study of implanted electrode systems," *Amer. Soc. Artif. Int. Organs, XVIII*:514-519 (1972).
- Schuder et al., "Defibrillation of 100 kg calves with asymmetrical, bi-directional, rectangular pulses," *Card. Res.*, 18:419-426 (1984).
- Schuder et al., "Development of automatic implanted defibrillator," *Devices & Tech. Meeting NIH* (1981).
- Schuder et al., "One-cycle bi-directional rectangular wave shocks for open chest defibrillation in the calf," *Abs. Am. Soc. Artif. Intern. Organs*, 9:16.
- Schuder et al., "Transthoracic ventricular defibrillation in the 100 kg calf with symmetrical one-cycle bi-directional rectangular wave stimuli," *IEEE Trans. BME*, 30(7):415-422 (1983).
- Schuder et al., "Transthoracic ventricular defibrillation with square-wave stimuli: One-half cycle, one-cycle, and multicycle waveforms," *Circ. Res.*, XV:258-264 (1964).
- Schuder et al., "Ultrahigh-energy hydrogen thyratron/SCR bi-directional waveform defibrillator," *Med. & Biol. Eng. & Comput.*, 20:419-424 (1982).
- Schuder et al., "Waveform dependency in defibrillating 100 kg Calves," *Devices & Tech. Meeting NIH* (1982).
- Schuder et al., "Waveform dependency in defibrillation," *Devices & Tech. Meeting NIH* (1981).
- Stanton et al., "Relationship between defibrillation threshold and upper limit of vulnerability in humans," *PACE*, 15:563, abstract 221 (Apr. 1992).
- Tang et al., "Strength duration curve for ventricular defibrillation using biphasic waveforms," *PACE*, 10: abstract no. 49 (Aug. 1987).
- Tang et al., "Ventricular defibrillation using biphasic waveforms of different phasic duration," *PACE*, 10: abstract no. 47 (Mar.-Apr. 1987).
- Tang et al., "Ventricular defibrillation using biphasic waveforms: The importance of phasic duration," *JACC*, 13(1):207-214 (1989).
- Walcott et al., "Comparison of monophasic, biphasic, and the edmark waveform for external defibrillation," *PACE*, 15:563, abstract 218 (Apr. 1992).
- Wathen et al., "Improved defibrillation efficacy using four nonthoracotomy leads for sequential pulse defibrillation," *PACE*, 15:563, abstract 220 (Apr. 1992).
- Wetherbee et al., "Subcutaneous patch electrode—A means to obviate thoracotomy for implantation of the automatic implantable cardioverter defibrillation system?" *Circ.*, 72:384, abstract no. 1536 (1985).
- Winkle "The implantable defibrillator in ventricular arrhythmias," *Hospital Practice*, pp. 149-165 (Mar. 1983).
- Winkle et al., "Improved low energy defibrillation efficacy in man using a biphasic truncated exponential waveform," *JACC*, 9(2):142A (1987).
- Zipes, "Sudden cardiac death," *Circulation*, 85(1):160-166 (1992).
- Product information for Model H MSA Portable Defibrillator (Bulletin No. 1108-2); 4 pp.
- Product information for MSA Portable Defibrillator (Bulletin No. 1108-1); 4 pp.

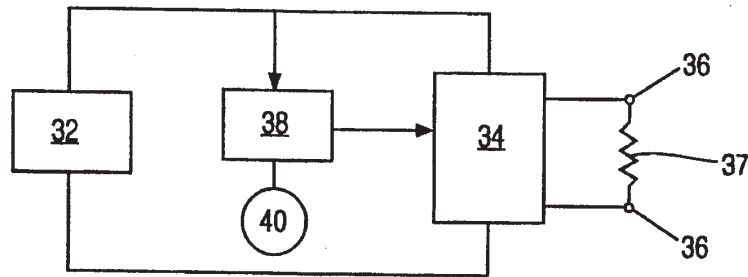
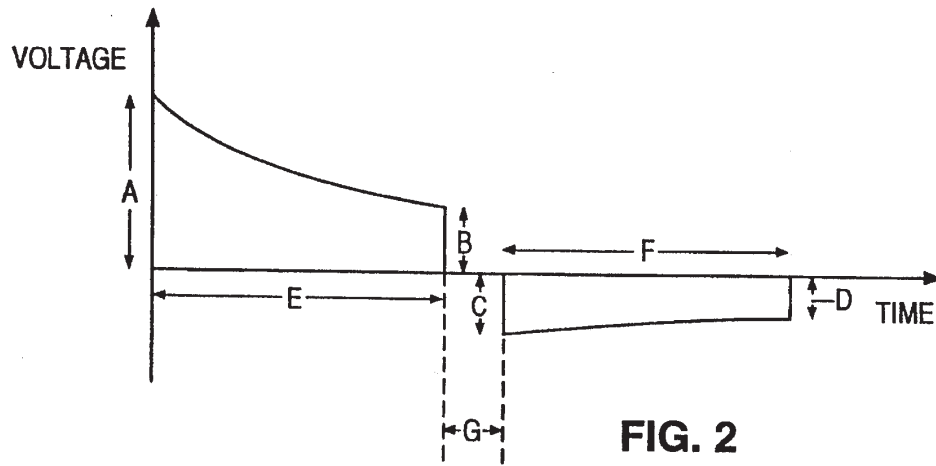
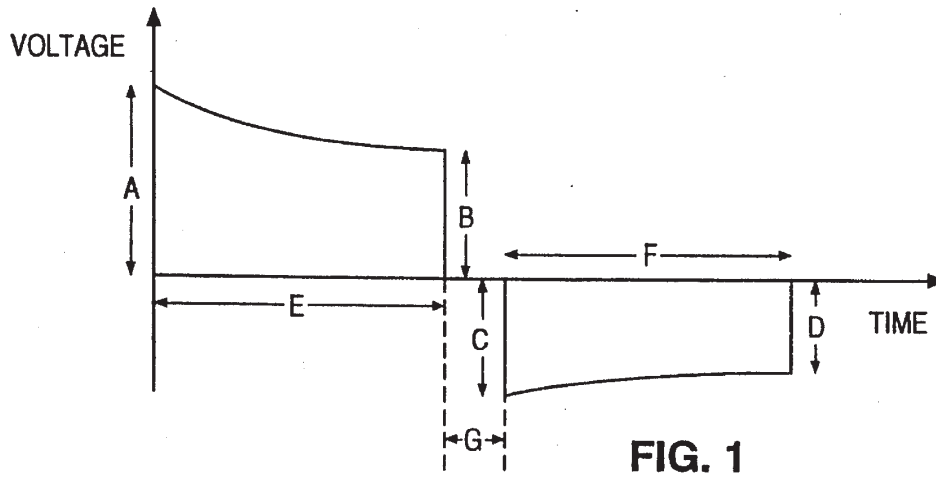

FIG. 3

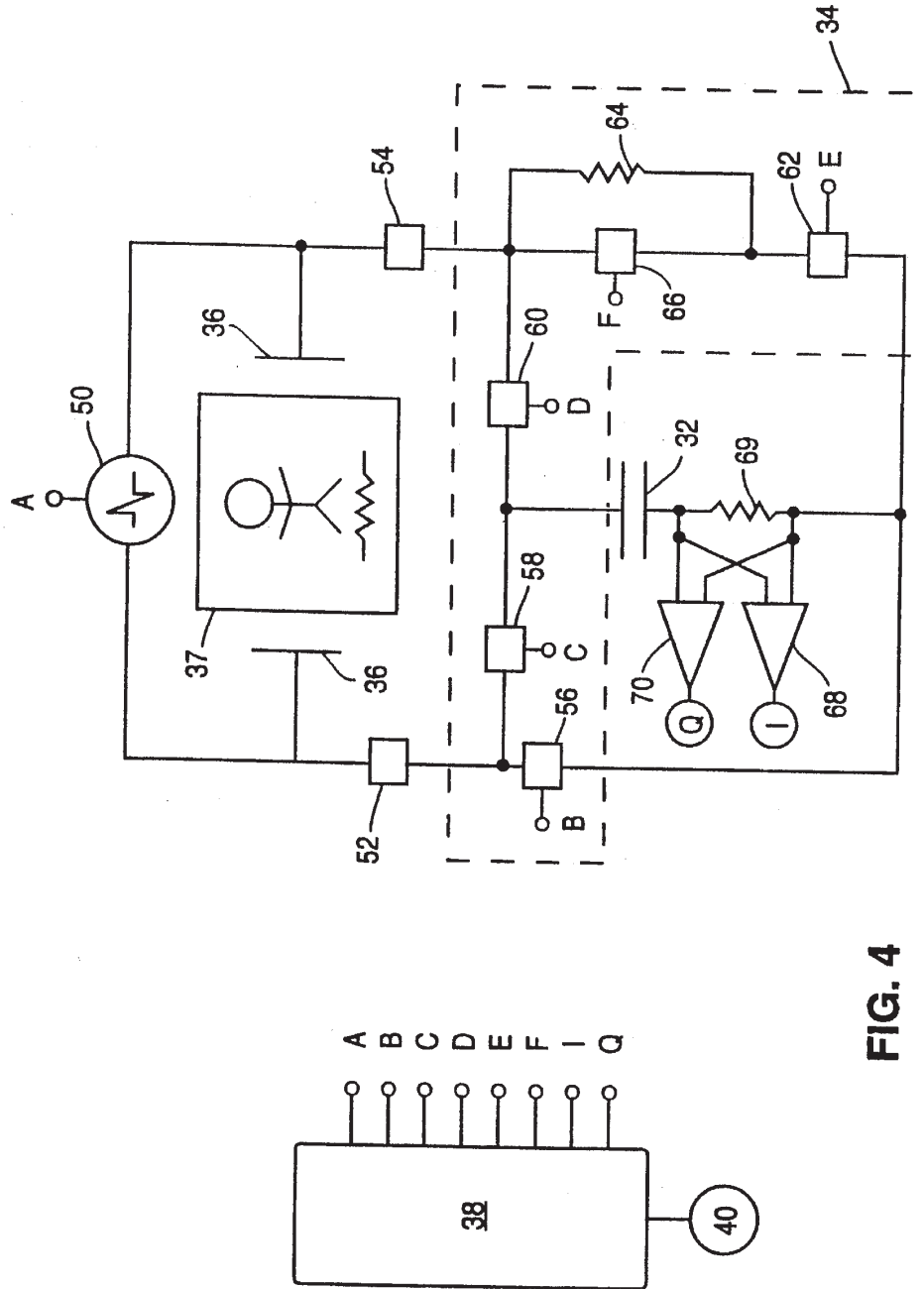

FIG. 4

# Explore Litigation Insights

Docket Alarm provides insights to develop a more informed litigation strategy and the peace of mind of knowing you're on top of things.

## Real-Time Litigation Alerts



Keep your litigation team up-to-date with **real-time alerts** and advanced team management tools built for the enterprise, all while greatly reducing PACER spend.

Our comprehensive service means we can handle Federal, State, and Administrative courts across the country.

## Advanced Docket Research



With over 230 million records, Docket Alarm's cloud-native docket research platform finds what other services can't. Coverage includes Federal, State, plus PTAB, TTAB, ITC and NLRB decisions, all in one place.

Identify arguments that have been successful in the past with full text, pinpoint searching. Link to case law cited within any court document via Fastcase.

## Analytics At Your Fingertips



Learn what happened the last time a particular judge, opposing counsel or company faced cases similar to yours.

Advanced out-of-the-box PTAB and TTAB analytics are always at your fingertips.

## API

Docket Alarm offers a powerful API (application programming interface) to developers that want to integrate case filings into their apps.

## LAW FIRMS

Build custom dashboards for your attorneys and clients with live data direct from the court.

Automate many repetitive legal tasks like conflict checks, document management, and marketing.

## FINANCIAL INSTITUTIONS

Litigation and bankruptcy checks for companies and debtors.

## E-DISCOVERY AND LEGAL VENDORS

Sync your system to PACER to automate legal marketing.