

TOUCH TECHNOLOGY ISSUE

# Information DISPLAY

**SID**  
SOCIETY FOR INFORMATION DISPLAY

Official Monthly Publication of the Society for Information Display • [www.informationdisplay.org](http://www.informationdisplay.org)

March 2010  
Vol. 26, No. 3

## The Best of Times for Touch

**"PRO-CAP" TOUCH  
TECHNOLOGY FOR  
SMALL-TO-MEDIUM  
MOBILE DEVICES**

**HAPTIC FORCE  
FEEDBACK AND  
AUTOMOTIVE  
TOUCH SCREENS**

**LARGE-SURFACE  
INTERACTIVE  
COMPUTING  
PLATFORMS**

**DOUBLE-DIGIT  
GROWTH  
FOR TOUCH  
MARKETPLACE**

**BUILDING A DEVICE  
WITH A GREAT  
"TOUCH EXPERIENCE"**

**IN-CELL  
TOUCH FOR LCDs**

TPK 2013  
Wintek v. TPK Touch Solutions  
IPR2013-00567

Patent Holder Exhibit 2013  
IPR2013-000567  
IPR2013-000578

**Plus**  
**First Looks at  
Display Week 2010**  
**Journal of the SID**  
**April Contents**

# IRTOUCH

S Y S T E M S

## IRTOUCH Multi-Touch is Ready for Windows 7

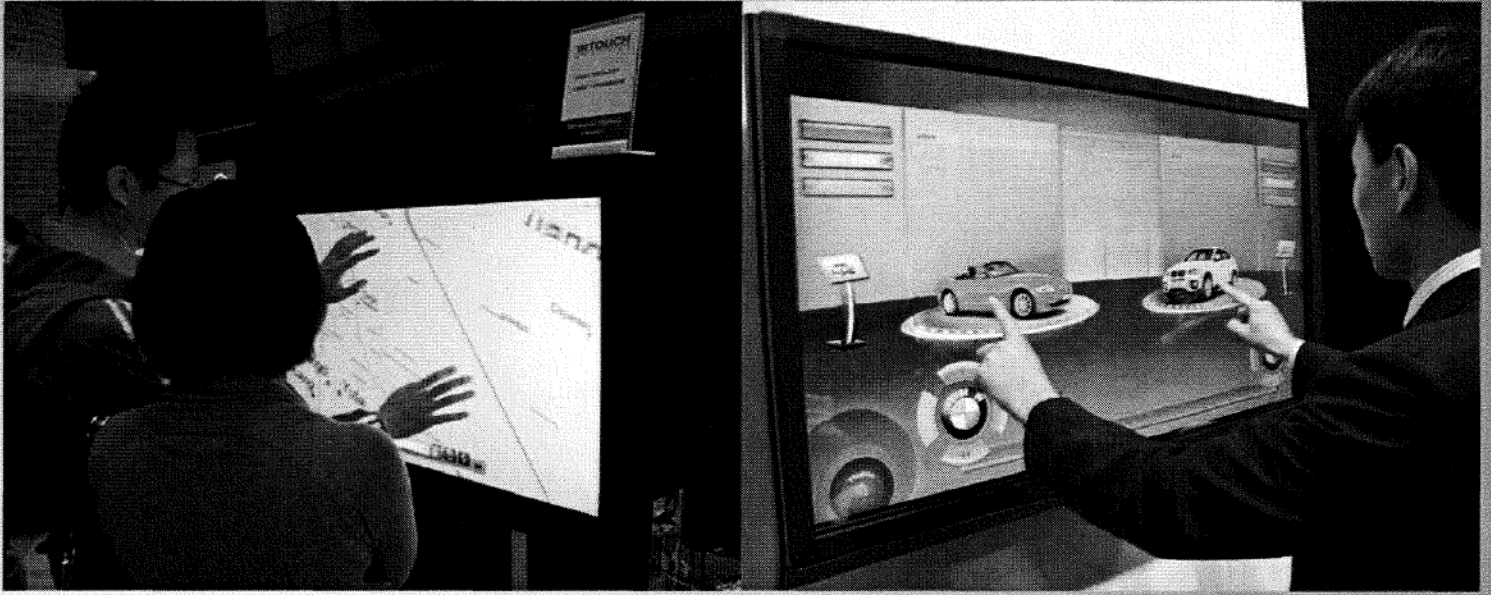

IRTOUCH multi-touch screen enriches user interface experience by supporting two touch points, enabling gesture commands, such as zoom, rotate and drag. Fully compliant with Windows 7, the IRTOUCH platform seamlessly supports multi-touch applications on Windows 7.

- Best Optical Performance
- High Reliability
- Enhanced Sunlight Performance
- Multi-Touch

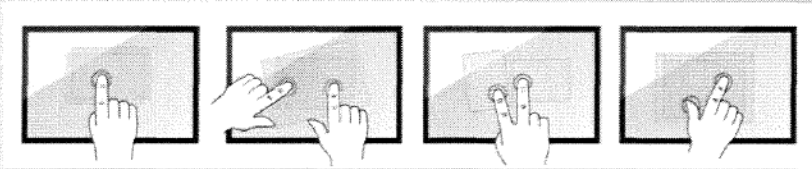

Sizes Available: 6.4"-100"

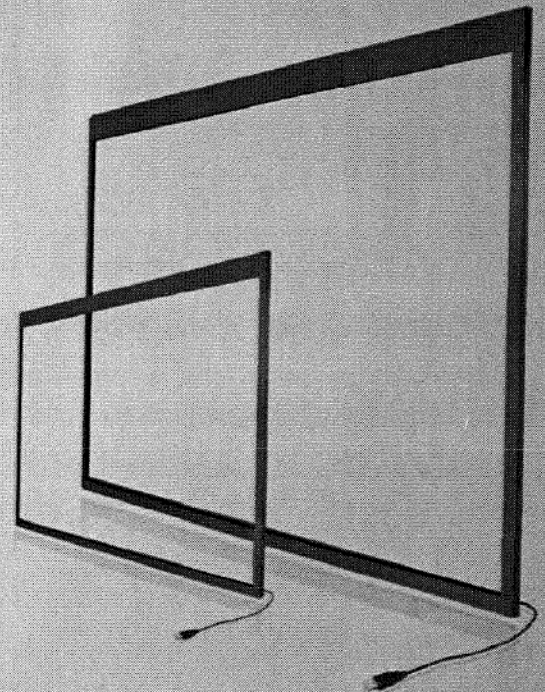

See us at Display Week 2010 Booth 1311  
[www.irtouch.com](http://www.irtouch.com) [www.irtouchusa.com](http://www.irtouchusa.com)



# Information DISPLAY

MARCH 2010  
VOL. 26, NO. 3

**COVER:** After decades of being behind the scenes, touch has come to the forefront of display development, impacting system design and user interfaces, and increasingly being integrated into the display itself.

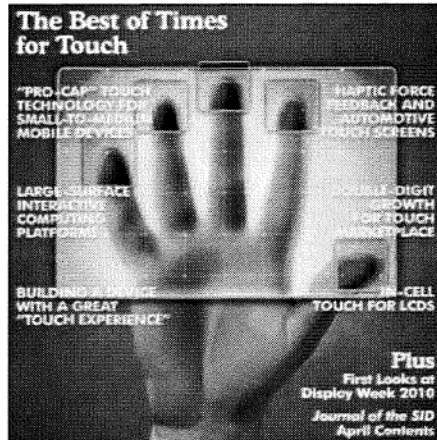

CREDIT: Cover design by Acapella Studios, Inc.  
Special thanks to Kevin Gillespie for his inspirational suggestions.

## Next Month in Information Display

### Digital Signage

- Indoor Digital Signage
- Outdoor LED Displays
- Digital Signage Marketplace

### Plus

- SID 2009 Honors and Awards
- Display Week First Looks
- Symposium Preview
- Exhibit Preview
- Journal of the SID May Contents

INFORMATION DISPLAY (ISSN 0362-0972) is published 10 times a year for the Society for Information Display by Palisades Convention Management, 411 Lafayette Street, 2nd Floor, New York, NY 10003; William Klein, President and CEO. EDITORIAL AND BUSINESS OFFICES: Jay Morreale, Editor-in-Chief, Palisades Convention Management, 411 Lafayette Street, 2nd Floor, New York, NY 10003, telephone 212/460-9700. Send manuscripts to the attention of the Editor, ID, Director of Sales: Michele Klein, Palisades Convention Management, 411 Lafayette Street, 2nd Floor, New York, NY 10003; 212/460-9700. SID HEADQUARTERS, for correspondence on subscriptions and membership: Society for Information Display, 1475 S. Bascom Ave., Ste. 114, Campbell, CA 95008; telephone: 408/879-3901, fax: -3833. SUBSCRIPTIONS: Information Display is distributed without charge to those qualified and to SID members as a benefit of membership (annual dues \$100.00). Subscriptions to others: U.S. & Canada: \$75.00 one year, \$7.50 single copy; elsewhere: \$100.00 one year, \$7.50 single copy. PRINTED by Sheridan Printing Company, Alpha, NJ 08865. Third-class postage paid at Easton, PA. PERMISSIONS: Abstracting is permitted with credit to the source. Libraries are permitted to photocopy beyond the limits of the U.S. copyright law for private use of patrons, providing a fee of \$2.00 per article is paid to the Copyright Clearance Center, 21 Congress Street, Salem, MA 01970; reference serial code 0362-0972/10/\$1.00 + \$0.00. Instructors are permitted to photocopy isolated articles for noncommercial classroom use without fee. This permission does not apply to any special reports or lists published in this magazine. For other copying, reprint or republication permission, write to Society for Information Display, 1475 S. Bascom Ave., Ste. 114, Campbell, CA 95008. Copyright © 2010 Society for Information Display. All rights reserved.

## 2 Editorial

*The Limitless Horizon for Touch*

Stephen P. Atwood

## 3 Industry News

Jenny Donelan

## 4 Guest Editorial

*The Best of Times*

Geoff Walker

## 6 Anniversary of a Prediction

Paul Drzaic

## 8 Frontline Technology: LCD In-Cell Touch

*Imagine being able to touch the surface of any display with your finger or a stylus and have the location of your touch instantly identified down to the exact pixels. Imagine this happening with no cover glass or special coatings or any other obstruction in front of the display, and with minimal change inside the display. That's the promise of in-cell touch. The problem is that the promise remains mostly out of reach. This article explores that promise and its current status in detail.*

Geoff Walker and Mark Fihn

## 16 Frontline Technology: Projected-Capacitive Touch Technology

*Projected-capacitive touch has grown extremely rapidly from obscurity in 2006 to the number-two touch technology in 2009. This article examines all aspects of projected-capacitive touch technology, delving into sensor, controller, and module details.*

Gary Barrett and Ryomei Omote

## 22 Display Marketplace: The State of the Touch-Screen Market in 2010

*Touch screens are in widespread use, due to the intuitive interfaces they enable, which can save time and increase productivity. Falling component prices have also spurred adoption, with consumer products increasingly being designed around touch screens. Touch-screen devices are also widely perceived as cool and fun.*

Jennifer Colegrove

## 26 Enabling Technology: Touch Screens and Touch Surfaces are Enriched by Haptic Force-Feedback

*Tactile feedback can enable more effective use of touch screens, particularly in automotive applications where driver distraction is a problem. The number of technologies used to produce haptic effects continues to increase, providing many options and opportunities for system designers.*

Bruce Banter

## 31 Journal of the SID April Contents

## 32 Enabling Technology: Beneath the Surface

*Surface computing is about integrating the physical world and the virtual world through the use of vision-based touch. While Microsoft's Surface product is the best-known implementation of surface computing, it is far from the only one. Expanding university research on touch continues to make use of vision-based touch as a foundation, which in turn will help move surface computing toward full commercialization.*

Geoff Walker and Mark Fihn

## 36 Making Displays Work for You: Taking Touch to New Frontiers: Why It Makes Sense and How to Make It Happen

*Touch interfaces are appearing in everything from consumer devices to industrial equipment, not because touch is "in fashion," but because it provides a truly better form of human-device interaction. This article examines the advantages of gesture-based touch interfaces and the key steps to building a device with a great touch experience.*

Mark Hamblin

## 40 Display Week 2010 First Looks: Green Technology

Don Carkner

## 42 Display Week 2010 First Looks: Touch Technology

Jenny Donelan

## 44 SID News: Latin Display 2009

## 46 Official SID 2010 Housing Request Form

## 48 Sustaining Members

## 48 Index to Advertisers

For Industry News, New Products, Current and Forthcoming Articles,  
see [www.informationdisplay.org](http://www.informationdisplay.org)



## The Limitless Horizon for Touch

by Stephen P. Atwood

If you are just opening this March issue, I hope you notice that it is thicker than the previous few. The reason is fairly simple. Our Guest Editor Geoff Walker brought to us an outstanding array of submissions and we just could not bring ourselves to cut anything out. Touch technology has been around for as long as I have been in the display business. In fact, I've worked full time at three different touch

businesses and consulted with several more during my career. I can even remember some of the first demonstrations of various acoustic and capacitive touch technologies and I have had the privilege of meeting many of those inventors.

But I doubt any of those early inventors could have envisioned the massive scale of adoption and utilization that has taken place around mobile devices. Seemingly, almost overnight everyone is using touch with ease to navigate complex interactions with their iPhones, PDAs, and other devices. Early complaints about accuracy, response, uncertainty, and image quality seem to have evaporated like snow on a warm day. Of course, we know those issues have not really evaporated; rather, a significant number of very talented engineers have been hard at work innovating for the past several years and, with some assistance from the semiconductor and materials industry, have circumvented these problems enough to please consumers. One of the most frequent complaints about early PDAs was the accuracy of their resistive screens. If you had an early PDA device with stylus input, you no doubt struggled at times with the gesture-recognition software and became frustrated by the on-screen keypad when the stylus picked the wrong letters or numbers. Similarly, using your finger to select things was like using a shotgun to hunt ants. Sure you could get the target, but the collateral impact was substantial. And, even if none of this deterred you, then the eventual degradation of the screen due to stylus-induced wear was disappointing.

Projected-capacitive screens, with their matrix of absolutely addressed conductors and rigid glass surfaces, have really changed the experience. Now there is little calibration error or drift, the contact with your finger can be very light, which allows for more precise selections, and I have yet to see a pro-cap screen worn out by normal use. That said, we are far from the ideal solution because the typical pro-cap screen does not support stylus use and is more expensive than a similar resistive screen. Efforts to remedy this situation are revealed in the Frontline Technology feature "Projected-Capacitive Touch Technology" written by Gary Barrett and Ryomei Omote. Barrett, incidentally, is one of those fundamental inventors of touch technology I referred to in the beginning of this editorial. If you talk to him, he can expound on the many technical and business challenges the industry faced in its infancy. It took a lot of hard work and creativity to get to where we are today. But don't let me leave you with the impression that resistive screens are outmoded either. Engineers have made great strides with resistive technology, employing more durable materials, better optical coatings, and even high-resolution matrix addressing to produce accuracy similar to that of pro-cap screens.

So, does this mean the quest is basically over? Are we at the shores of the touch-technology journey and ready to unload the boats for good? Have we discovered everything that needs to be discovered? Not a chance! If you have read any of our previous issues on this topic you know the theme: Touch keeps getting better, but there is no one technology that does everything or meets the needs of all applications.

(continued on page 35)

## Information DISPLAY

**Executive Editor:** Stephen P. Atwood  
617/306-9729, satwood@azonix.com

**Editor-in-Chief:** Jay Morreale  
212/460-9700, jmorreale@pcm411.com

**Managing Editor:** Jenny Donelan  
603/924-9628, jdonelan@pcm411.com

**Administrative Assistant:** Ralph Nadell

**Sales Manager:** Danielle Rocco

**Sales Director:** Michele Klein

### Editorial Advisory Board

Stephen P. Atwood, Chair  
*Crane/Azonix Corp., U.S.A.*

Bruce Gnade  
*University of Texas at Dallas, U.S.A.*

Allan Kmetz  
*Consultant, U.S.A.*

Larry Weber  
*Consultant, U.S.A.*

### Guest Editors

Solid-State Lighting  
*Jeffrey Spindler, Eastman Kodak Co.*

Flexible and Ultra-Low-Power Displays  
*Rob Zehner, E Ink Corp.*

3-D Technology  
*Brian T. Schowengerdt, University of Washington*

OLED Technology  
*Mike Hack, Universal Display Corp.*

LCD Technology  
*Shin-Tson Wu, University of Central Florida*

Green Manufacturing  
*Greg Gibson, NexTECH FAS*

Touch Technology  
*Geoff Walker, NextWindow*

The opinions expressed in editorials, columns, and feature articles do not necessarily reflect the opinions of the Executive Editor or Publisher of *Information Display Magazine*, nor do they necessarily reflect the position of the Society for Information Display.

# industry news

## Tyco Electronics' Elo TouchSystems Rolls Out IntelliTouch Plus Technology

by Jenny Donelan

IntelliTouch Plus technology from Elo TouchSystems, a pioneering touch technology company founded in 1971, is, according to Elo, the first surface-acoustic-wave (SAW) touch technology with multi-touch capabilities, and also the first SAW technology to receive the Windows 7 logo. IntelliTouch Plus records two simultaneous touch locations anywhere on the screen with three axes of touch. The technology is designed to offer OEMs, application developers, and other customers tools to leverage the Windows 7 touch interface.

IntelliTouch Plus will be commercially available early this year, in the form of screen components in sizes ranging from 17 through 32 in. for consumer touch monitors as well as all-in-one touch computers running Windows 7.

In addition, a 22-in. open-frame touch monitor will be available later in 2010.

A new Elo TouchSystems touch driver, also compatible with Windows 7, will be available this year for current Elo monitors and will offer the addition of digitized gestures to basic single-touch functionality. No new hardware is needed. This proprietary technology will enable real-time single-finger gesture recognition on all Elo touch monitors, a capability the company says can be easily integrated into all Elo touch monitors for compatibility with the Windows 7 operating system. ■

be used to commercialize FlatFrog's product line of large, high-performance multi-touch in-glass displays. **Tyco Electronics, Ltd.**, a Switzerland-based designer, manufacturer, and marketer of engineered electronic components and undersea telecommunication systems, has acquired **Sensitive Object, SA**, a France-based developer of touch-input technology, for approximately \$62 million. Elo TouchSystems (mentioned in article earlier) is also a Tyco business. **Amazon.com** has reportedly bought Touchco, a small start-up company that makes flexible touch screens. According to a February 3, 2010, article in the *New York Times*, "Amazon Said to Buy Touch Start-up," Amazon.com will merge Touchco with the Kindle hardware division, Lab 126, in California. Touchco makes flexible, see-through, and pressure-sensitive touch screens. The company's touch-screen technology can reportedly make a distinction between the singular pressures applied by either a finger or stylus. This news was unconfirmed by Amazon at press time. ■

## News Briefs

**FlatFrog Laboratories AB**, a developer and manufacturer of optics-based multi-touch kits and subsystems, recently announced that it has raised €12.5 million (approximately US\$8 million) in new equity from international strategic and institutional investors. Proceeds from this new round of funding will

## Touchdown on MARS - The Next Generation of Multi-Touch!

### Multi-Touch Resistive Touch Module **NEW!**

The Multi-Analog Resistive Sensor (MARS) propels resistive technology to the next level with Multi-Touch capabilities, delivering versatility to any application.

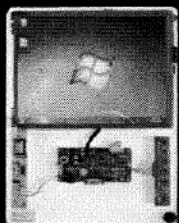

#### Featuring

- Multi-Touch (10-Fingers)
- True Touch Gesture
- Palm-Rejection
- Finger, Gloved Finger or Stylus

#### Applications

- Cockpit Controls
- In-flight Entertainment
- Medical Instruments
- Military Equipment
- Handheld Devices

MARS blasts into the module mix, joining our other multi-touch product...

#### ExtremeTouch Projected Capacitive Modules

ExtremeTouch modules offer innovation and durability in a portable, plug and play design that integrates easily into almost any application.

#### Featuring

- Highly Accurate
- Single or Two-Finger Touch
- Reliable Despite On-Screen Contaminants
- Finger, Gloved Finger or Stylus

#### Applications

- GPS
- NET Books
- Tablet Computers
- Gaming Consoles

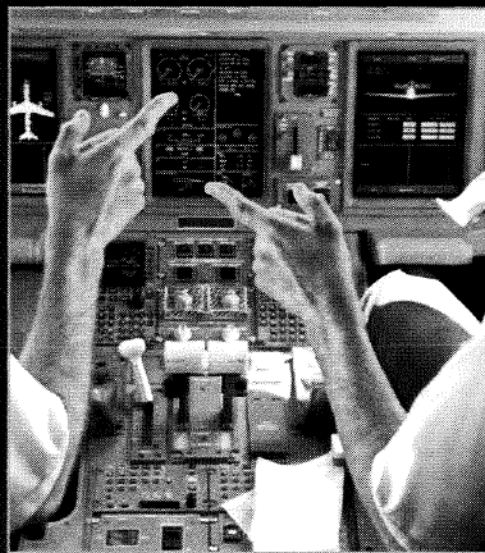

sales@touchintl.com | 512-832-8292 | www.touchinternational.com

**TouchInternational**  
the Next Generation in Touch Innovation

See Us at Display Week 2010 in Seattle



## The Best of Times

by Geoff Walker

It's hard to imagine how the touch industry could be any more exciting than it is right now. Consider the following, especially in light of the current worldwide economic crisis:

- Consumer-device manufacturers are adopting touch at a very rapid rate.
- New touch technologies are being created.
- Touch is growing 3X (units) to 10X (revenue) faster than the display industry.
- Existing touch technologies are being refined and enhanced.
- Projected-capacitive-touch revenue has rocketed from \$20 million to \$600 million in 3 years.
- The pace and scope of university research on touch has accelerated.
- Display Week has dedicated one of the four half-day Sunday Short Courses to touch.
- SID has designated touch as a special area of focus and created symposium sessions exclusively for touch.
- Touch startups are being funded or acquired when they rarely would have been in the past (FlatFrog, Touchco, Sensitive Objects ...).
- New conferences and shows devoted to touch are being created worldwide.

One of the several factors driving this excitement is that there is no perfect touch technology. Each of more than a dozen technologies has specific strengths and weaknesses. For example, there still is not one touch technology for a smartphone that has high durability, high optical performance, multi-touch, a flush surface (edge-to-edge glass or plastic), and can be touched with any object including a small-tipped throw-away stylus – at any cost! Yet all of these characteristics are in strong demand from smartphone OEMs.

Another factor is the variation in requirements across different touch applications. For example, how many simultaneous touches does a touch technology need to support? The answer depends on the application and the device size. In small, narrow-bordered mobile devices such as smartphones and tablets, the ability to recognize and track many touches is particularly useful when implementing “grip suppression” algorithms (see the article in this issue on projected-capacitive touch technology for more details). In netbooks and notebooks, one hand is almost always used to hold the screen steady, so the maximum number of touches that the other hand can apply is limited to five, and since it's only one hand, three or four is probably a practical limit. In desktop monitors and all-in-one computers, there are zero applications today that require more than two touches, so the device OEMs currently have little interest in incorporating (more expensive) touch screens that can support more than two touches. In large-format (>30-in.) displays, the majority of applications today are “point-and-click” that require only a single touch (excepting CNN-TV's multi-touch display, of course). On the other hand, it's not much of a stretch to envision multi-player games and educational applications on large-format displays requiring 4-10 touches in the near future.

In reality, the maximum number of touches is just one of more than 40 characteristics that define a touch screen. Ultimately, what really matters is the user experience, which depends on all of the touch screen's characteristics, the user interface, the application, and the operating system all coming together to work in harmony to do what

*(continued on page 45)*

## 2010 SID International Symposium, Seminar, and Exhibition

### Display Week 2010

### Seattle, Washington

### May 23–28, 2010



Seattle, WA • May 23-28, 2010 • [www.sid2010.org](http://www.sid2010.org)

Have you forgotten  
about this issue?  
Log onto [informationdisplay.org](http://informationdisplay.org)  
and click “ID Archive.”

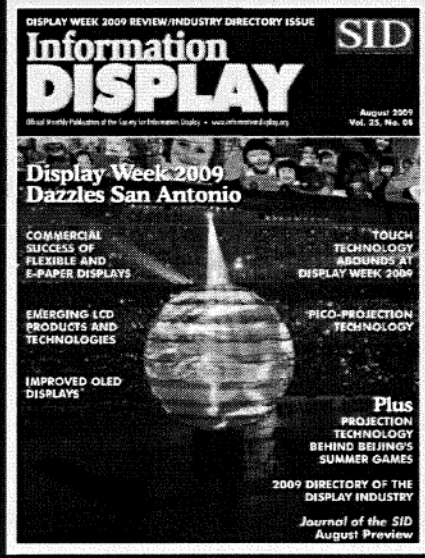

There are times when the best way to make your message heard is to stay quiet and let someone else do the talking. True, we could tell you ourselves about the wide variety of industries we serve all over the globe, or how some of our partnerships stretch back decades. But our customers are really the best people to explain how we make their jobs easier and help their

companies succeed and remain competitive. Their stories are proof that you can expect unparalleled quality and reliability from us – and world-class support and services to match. Wondering what Merck Chemicals can do for you? Explore real partnerships and real challenges in our customers' own words, as they take the chair – at [www.merck-chemicals.com](http://www.merck-chemicals.com)

What's it like working with Merck Chemicals?

Zoom in on the story!  
And read how we put smiles on  
our customers' faces at  
[www.merck-chemicals.com/testimonials](http://www.merck-chemicals.com/testimonials)

That's what's in it for you. Merck Chemicals



The Barcelona® Chair by Knoll, Inc.



Visit us at DISPLAY WEEK 2010,  
Washington | Hall 4 A-E | Booth 323  
[www.merck4displays.com](http://www.merck4displays.com)





## Anniversary of a Prediction

by Paul Drzaic

President, Society for Information Display

There's a quotation generally attributed to the famous U.S. baseball player Yogi Berra: "It's tough to make predictions, especially about the future." While we hear predictions all the time from various sources, it's uncommon for these predictions to accurately portray the future. Even rarer, and astonishing, are the predictions that appear controversial or even outrageous when they are made, but are proven to be true over time. For this column, I'd like to celebrate a prediction made during a keynote address at the SID Symposium in 2005 that to my mind fits the "astonishing" description.

President Sang-Wan Lee of Samsung Electronics provided the talk I'm referring to. His address was entitled "LCD Revolution – The 3rd Wave," and it provided a look back at the penetration of large-area active-matrix liquid-crystal-display (AMLCD) technology into notebook and desktop applications (the 1st and 2nd waves). He presented an impressive array of statistics showing progress in AMLCDs, including dramatic performance improvements in response time, brightness, contrast ratio, color depth, and viewing angle. President Lee also noted the industry's multi-billion dollar investment in AMLCD manufacturing capabilities. At that time, this meant 20 companies operating 79 manufacturing lines worldwide, including one Gen 7 and four Gen 6 fabs. Over 100 million LCD monitor units were shipped that year. Based on these successes, President Lee projected that AMLCDs would next dominate the television market, supplanting CRTs, plasma displays, and projection displays.

It's important to note the electronic-display landscape in 2005. The retail price for 40–42-inch LCD televisions was approaching the \$2500 range. It was possible to purchase LCD TVs for less than \$1500, but only in 30-inch and smaller sizes. CRTs held over 70% of the market share for televisions, with AMLCDs, plasma displays, and projection displays fighting tooth and nail for the balance. Most commonly, commercial AMLCD TV sizes topped out at around 42 inches, while plasma and projection displays were available up to 60 inches. While everyone was relatively confident that CRTs would continue to lose market share to flat-panel displays, it was not at all clear how quickly that erosion would take place or which mix of technologies would win.

That landscape explains why Sang-Wan Lee's predictions were so astounding at the time. Looking ahead to 2010, he made the following claims:

- AMLCD televisions would attack both CRTs at the low end and plasma/projection screens at the high end, competing in cost, quality, and size.
- A target of 100 million AMCLD televisions by 2010 was achievable – conventional forecasts were in the 60–70 million unit range.
- The retail price for a 32-inch AMLCD would be less than \$1000.
- Commercial LCDs would compete head to head with plasma/projection units in sizes up to 70 inches.
- The industry would continue to invest in large, new-generation fabs up to Gen 9.
- New applications would emerge based on this availability.

Attending the talk, I distinctly heard the audience audibly reacting to these claims – the price points, unit volumes, and commercial sizes were viewed as extremely

*(continued on page 45)*

### SID Executive Committee

President: P. Drzaic  
President-Elect: M. Anandan  
Regional VP, Americas: T. Voutsas  
Regional VP, Asia: S. Naemura  
Regional VP, Europe: J.-N. Perbet  
Treasurer: B. Berkeley  
Secretary: A. Ghosh  
Past President: L. Weber

### Directors

Bay Area: S. Pan  
Beijing: B. P. Wang  
Belarus: V. Vyssotski  
Canada: T. C. Schmidt  
Dayton: D. G. Hopper  
Delaware Valley: J. W. Parker III  
Detroit: J. Kanicki  
France: J.-P. Parneix  
Hong Kong: H. Leung  
India: G. Rajeswaran  
Israel: G. Golan  
Japan: N. Ibaraki  
Korea: K. W. Whang  
Latin America: A. Mammana  
Los Angeles: L. Tannas  
Mid-Atlantic: D. Morton  
Mid-Europe: G. Oversluizen  
New England: S. Atwood  
Pacific Northwest: A. Abileah  
Russia: I. N. Compansets  
San Diego: T. Striegler  
Singapore: C. C. Chao  
Southwest: S. O'Rourke  
Taipei: Y. T. Tsai  
Texas: Z. Yaniv  
U.K. & Ireland: I. Sage  
Ukraine: V. Sergan  
Upper Mid-West: B. Bahadur

### Committee Chairs

Academic: P. Bos  
Archives/Historian: P. Baron  
Bylaws: A. Kmetz  
Chapter Formation: Z. Yaniv  
Convention: D. Eccles  
Definitions & Standards: J. Misceli  
Honors & Awards: C. King  
Long-Range Planning: M. Anandan  
Membership: S. Pan  
Nominations: L. Weber  
Publications: B. Gnade  
Senior Member Grade: M. Anandan

### Chapter Chairs

Bay Area: D. Armitage  
Beijing: N. Xu  
Belarus: V. Vyssotski  
Canada: A. Kitai  
Dayton: F. Meyer  
Delaware Valley: J. Blake  
Detroit: S. Pala  
France: J. P. Parneix  
Hong Kong: H. S. Kwok  
India: S. Kaura  
Israel: B. Inditsky  
Japan: K. Kondo  
Korea: Y. S. Kim  
Latin America: V. Mammana  
Los Angeles: P. Joujon-Roche  
Mid-Atlantic: Q. Tan  
Mid-Europe: A. Jelfs  
New England: B. Harkavy  
Pacific Northwest: A. Silzars  
Russia: S. Pasechnik  
San Diego: T. D. Striegler  
Singapore/Malaysia: X. Sun  
Southwest: B. Tridle  
Taipei: Y. Tsai  
Texas: S. Peana  
U.K. & Ireland: S. Day  
Ukraine: V. Sergan  
Upper Mid-West: P. Downen

### Office Administration

Office and Data Manager: Jenny Bach

### Society for Information Display

1475 S. Bascom Ave., Ste. 114  
Campbell, CA 95008  
408/879-3901, fax -3833  
e-mail: office@sid.org  
http://www.sid.org



# Architects of World Class Display Enhancements

*EuropTec USA is a specialist in glass processing and fabrication for the display industry. As an expert in various finishing and processing technologies, we design and manufacture products for display applications.*

## PRODUCT & CAPABILITIES:

- EagleEtch® & EagleEtch Plus™ - industry's best performing Anti-Glare Glass
- Anti-Reflective Glass
- IR blocker, EMI shielding
- Laminating (conventional & pressure sensitive)
- Vandal proof filters
- Silk Screening
- Chemical Strengthening
- Heat Tempering
- Technical Processing: CNC Cutting, Edgework, Beveling

## APPLICATIONS:

- Touch Panels
- ATMs & Kiosks
- Military & Avionics
- Ruggedized Displays – Computers, Equipment, Military



GLT. The World's Most Efficient LED-Based Edge-Lighting Solutions.

GLT has the better solution for your edge-lit applications!

### LCD Backlighting

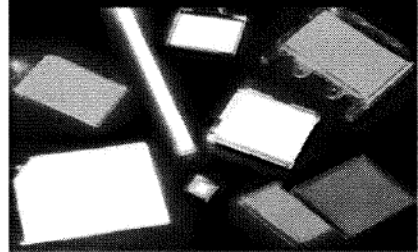

### Keyboards/Keypads



### Egress Lighting



### General Illumination

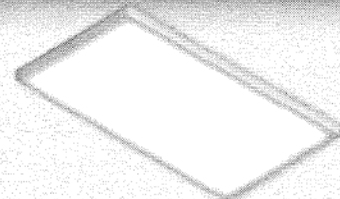

423 Tuna Street  
Clarksburg, WV 26301  
Tel: 304-624-7461  
www.europotec.com  
europotecusa@europotec.com



See Us at Display Week 2010 in Seattle

440-922-4584  
info@glthome.com  
www.glthome.com

See Us at  
Display Week 2010 in Seattle

# LCD In-Cell Touch

*Imagine being able to touch the surface of any display with your finger or a stylus and have the location of your touch instantly identified down to the exact pixels. Imagine this happening with no cover glass or special coatings or any other obstruction in front of the display, and with minimal change inside the display. That's the promise of in-cell touch. The problem is that the promise remains mostly out of reach. This article explores that promise and its current status in detail.*

by Geoff Walker and Mark Fihn

**T**HE term “in-cell touch” generally refers to the implementation of a touch sensor inside the cell of a liquid-crystal display (LCD). While the term and technology have been applied to touch sensors integrated into plasma-display panels, electrophoretic (electronic paper) displays, and OLEDs, this article examines only the application in LCDs.

LCD in-cell touch currently exists in three forms, only one of which is physically inside the LCD cell. The three forms are as follows:

- **In-cell:** The touch sensor is physically inside the LCD cell. The touch sensor can take the form of light-sensing elements, micro-switches, or capacitive electrodes.

*Geoff Walker is the Marketing Evangelist & Industry Guru at NextWindow, the leading supplier of optical touch screens. He is the Guest Editor for this issue of Information Display, is a recognized touch-industry expert who has been working with touch screens for 20 years. He can be reached at 408/506-7556 and gwalker@nextwindow.com. Mark Fihn is publisher of the Veritas et Visus newsletters, focused on the technologies and markets related to flexible displays, display-related standards and regulations, 3-D displays, high-performance displays, and touch screens. He can be reached at 254/791-0603 or mark@veritasetvisus.com.*

- **On-cell:** The touch sensor is an X-Y array of capacitive electrodes deposited on the top or bottom surface of the color-

filter substrate. Strictly speaking, when the electrodes are on the bottom surface of the substrate they are physically inside

**Table 1:** The difficulty of integrating each of 11 touch technologies as out-cell touch is shown as green (easy), yellow (medium), and red (hard)

| Touch Technology                              | Difficulty of Out-Cell Integration   |
|---|--|
| Analog & Digital Resistive                    | None   |
| Projected Capacitive                          | None   |
| Optical                                       | Cameras & reflectors can be mounted on top of the LCD cell; no cover glass is required   |
| Traditional Infrared                          | A PCB must surround the entire LCD; no cover glass is required   |
| Surface Capacitive                            | The metal LCD frame cannot contact the touch-screen glass and must be grounded   |
| Surface Acoustic Wave                         | The reflectors and transducers on the touch-screen glass must be protected   |
| Waveguide Infrared (RPO)                      | Waveguides and sensors must be mounted on the surface of the touch-screen glass; IR LEDs must be attached to the edge of the glass |
| Acoustic Pulse Recognition (Elo TouchSystems) | Touch-screen mounting is critical  |
| Dispersive Signal Technology (3M)             | Touch-screen mounting is critical  |
| Force Sensing                                 | Touch-screen mounting is critical  |
| Vision-Based Optical                          | Not applicable (rear-projection only)  |

the cell – but this is still usually called “on-cell” because of the type of electrodes. (This is a good illustration of the fact that the terminology for in-cell touch is still evolving.)

- **Out-cell:** This new term, coined in 2009 by AU Optronics Corp., describes the configuration in which a standard touch screen (usually only resistive or projected capacitive) is laminated directly on top of the LCD during module manufacturing. Unlike the other two, this configuration typically requires an additional piece of glass – even though it is technically possible to use a film–film resistive touch screen in this case.

Because these terms and the technology that they describe are quite new, there is still quite a bit of variation in their use in technical and marketing documents. Caution is advised while reading any relevant material; “on-cell” may often be used to describe something that is actually “out-cell,” and vice-versa.

### Out-Cell Touch

Out-cell is basically just the integration of a touch solution at the LCD-module manufacturer. This is not fundamentally different than the touch integration that is often performed by third-party integrators today. The major difference is that it is likely to be lower cost, which means that out-cell is probably going to become a general trend, one most likely to occur with technologies that are easy to integrate. Table 1 categorizes all current touch technologies in terms of the difficulty of integrating them as out-cell touch.

As shown in Table 1, resistive and projected-capacitive touch screens are the most likely candidates for out-cell integration. These two most commonly used technologies accounted for over 95% of the total number of touch screens shipped in 2009. Both are often attached to LCDs by third-party integrators, so it is easy for the LCD-module manufacturer to do the same. Projected-capacitive sensors are increasingly being made on converted color-filter fab lines, so LCD manufacturers have easy access to the technology. All of these factors are causing a number of well-known resistive and projected-capacitive touch-screen manufacturers to begin to work closely with major LCD manufacturers on out-cell integration. Among the other touch technologies, only optical seems to be gaining

any acceptance from the LCD manufacturers in terms of out-cell integration.

### In-Cell and On-Cell Touch Technologies

There are currently three different touch technologies being used in in-cell and on-cell touch. They are summarized as follows:

- **Light Sensing (In-Cell):** This technology, also called “optical,” uses the addition of a photo-transistor into some or all of the LCD’s pixels. The screen can be touched with a finger, stylus, light-pen, or laser pointer. The touch-sensing array can also be used as a scanner. A cover-glass can be used to protect the LCD’s surface.
- **Voltage Sensing (In-Cell):** This technology, also called “switch sensing,” uses the addition of micro-switches for X and Y coordinates into each pixel or group of pixels. The screen can be touched with a finger or a stylus, within the damage limits of the LCD’s surface. A cover-glass cannot be used to protect the LCD’s surface.
- **Charge Sensing (In-Cell):** This technology, also called “pressed capacitive,” uses variable-capacitor electrodes in each pixel or group of pixels. The screen can be touched with a finger or stylus, within the damage limits of the LCD’s surface. A cover-glass cannot be used to protect the LCD’s surface.
- **Charge Sensing (On-Cell):** This technology, also called “capacitive sensing,” is basically the same as today’s projected capacitive. It uses an X-Y array of capacitive-sensing electrodes on the top surface of the color-filter substrate. The screen can be touched only with a finger. A cover-glass can be used to protect the LCD’s surface.

Table 2 shows which LCD manufacturers are working on each of the three in-cell/on-cell technologies. This list, based on investigation done by the authors, is undoubtedly both incomplete and inaccurate because not all manufacturers are forthcoming about their in-progress research. The authors take full responsibility for all errors and omissions.

The theoretical advantages of in-cell touch have always seemed very attractive. These include the following:

- Minimal or no added size, thickness, or weight (and therefore no effect on the

end product’s industrial design) in order to achieve the touch function.

- Theoretically unlimited (controller-dependent) multi-touch functionality, since each pixel or group of pixels should be individually detectable.
- Conceptually very high touch-performance, including low parallax error (assuming no cover-glass), very accurate and linear touch-point data (due to the unchanging underlying pixel matrix), and potentially higher resolution than the LCD (through inter-pixel interpolation when a sensor is present in each pixel).
- Theoretically much lower cost for the touch function, since the changes in an LCD’s manufacturing cost should be minimal.

In reality, all of these advantages have turned out to be compromised to some degree. The next several sections of this article delve into each of the three technologies and their advantages and disadvantages in more detail.

**Table 2:** In-cell and on-cell touch technologies are being investigated by various LCD manufacturers. The manufacturers with the most significant development efforts are shown in bold; green denotes each manufacturer’s primary focus.

| LCD Manufacturer  | Light Sensing | Voltage Sensing (in-cell or on-cell) | Charge Sensing |
|-------------------|---------------|--------------------------------------|----------------|
| AUO               | ✓             | ✓                                    | ✓              |
| Chi Mei Innolux   |               |                                      | ✓              |
| CPT               |               |                                      | ✓              |
| HannStar          | ✓             |                                      |                |
| <b>LG Display</b> | ✓             | ✓                                    | ✓              |
| NEC               |               |                                      | ✓              |
| <b>Samsung</b>    | ✓             | ✓                                    | ✓              |
| Seiko-Epson       |               |                                      | ✓              |
| <b>Sharp</b>      | ✓             |                                      | ✓              |
| Sony              | ✓             |                                      |                |
| TMD               | ✓             |                                      |                |

### Light Sensing

The concept of putting a light-sensing element into each pixel, announced first in a press release by TMD in 2003, was the first in-cell technology to grab the world's interest. TMD was also the first to issue a press release describing the concept of automatically switching between sensing the shadow of a finger in bright ambient light and sensing the reflection of the backlight from a finger in dim ambient light. In those early days, light-sensing in-cell touch seemed to be destined to take over the touch industry and make all conventional touch screens obsolete. By the end of 2007, most of the other major LCD manufacturers (AUO, LG Display, Sharp, etc.) had demonstrated similar technology. A conceptual illustration of light-sensing in-cell technology appears in Fig. 1.

The first commercial product using any form of in-cell touch was developed by Sharp in 2009. The product, the PC-NJ70A netbook shown in Fig. 2, uses light-sensing in-cell touch in a 4-in. continuous-grain (CG) silicon, 854 × 480 touchpad LCD. This LCD performs the same functions as a conventional opaque touchpad, with the addition of stylus support, two-finger multi-touch gestures, and limited scanning (shape recognition). The product, retailing at around \$800, is available only in the Japanese domestic market. Sharp has made it clear that the PC-NJ70A is a "technology experiment" rather than a high-volume commercial product.

The development of this product by Sharp illustrated several fundamental issues with light-sensing in-cell touch. These issues,

which have generally been acknowledged and/or confirmed by other LCD manufacturers, are as follows:

- The original concept of using reflected backlight to sense touch in low ambient light does not work if the on-screen image is black. Sharp's solution to this problem was to modify the netbook's LED backlight to emit more infrared (IR) light (which significantly increases power consumption) and to modify the in-pixel light-sensors to be more sensitive to IR. Because the LCD is transparent to IR, this solved the problem of being unable to sense touch on a black image.
- In bright ambient light, it is difficult to distinguish between the shadow of a touching object and the shadow of a proximate (non-touching) object. In dim ambient light it is difficult to distinguish between a reflection from the backlight and a reflection from an external light source. In essence, using a photo-sensor to reliably detect touch over the range of full sunlight to total darkness turned out to be much more difficult than expected.
- Putting a light-sensing element in every pixel turned out to be impractical because it consumed too much of the aperture (reducing efficiency) and required too much processing power. Sharp's solution to this problem was to use one light-sensing element for every nine pixels. This reduces the impact of the problems but has the disadvantage of also reducing the touch resolution to the

point where (a) scanning an image of something placed on the display is no longer practical and (b) the quality of digital ink (when using a stylus) is not good enough.

- The display function and the touch function tend to interfere with each other. Expressed by Sharp as "severe electromagnetic interference (EMI) problems," this prevents the netbook's touch function from operating as fast as a normal opaque touchpad. One of the authors spoke with an engineer who had worked on the development of the product at Sharp; the engineer said that on average, the touchpad worked at about 25% of the speed of a normal touchpad, which made it quite annoying to use.
- The amount of processing power needed to operate the overall touch function (e.g., process multi-touch gestures, run the scanning function, etc.) turned out to be much higher than anticipated. This, along with the addition of IR LEDs to the backlight, resulted in high power consumption, which noticeably shortened the netbook's battery life.

Sharp was not the first to recognize the "can't touch a black image in low ambient light" problem. Planar observed the same problem and published a paper in 2007<sup>1</sup> which proposed a novel solution: inject IR light into the edge of a cover glass and use frustrated total internal reflection (FTIR) to provide the reflected IR that's sensed by the in-pixel light sensors. This eliminates dependence on ambient light and the backlight. In 2009, Planar sold the intellectual property for this idea to a company whose identity remains a closely held secret. Whether it will be available for licensing to LCD manufacturers remains to be seen.

One fundamental problem that Sharp avoided by using CG silicon is that of the mobility of the backplane. The level of mobility needed to implement light-sensing in-cell technology limits the practical implementation to CG or LTPS, which, in turn, limits the maximum size of a light-sensing in-cell touch screen to about 20 in.

The net effect of all the above-described problems is that the development of light-sensing in-cell touch has slowed down a great deal since initial demonstrations. The current consensus among the major LCD manufacturers seems to be that commercialization of

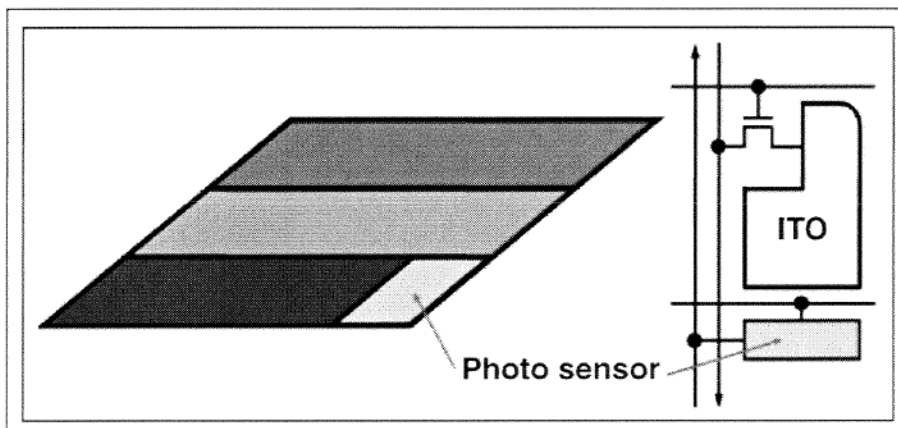

**Fig. 1:** In this conceptual illustration of light-sensing in-cell touch, a photo-sensing element occupies a portion of the aperture of one subpixel; the element is connected to X and Y control lines so it can be read individually. Source: DisplaySearch.

light-sensing in-cell touch is still relatively far in the future.

### Voltage Sensing

The basic concept of voltage-sensing in-cell touch is the same as that of the emerging “digital-resistive” touch technology. In essence, an X-Y switch matrix is overlaid on the LCD. In the case of an external digital-resistive touch screen, the matrix is formed by patterning the normally continuous transparent ITO conductors on the substrate and cover sheet of an analog-resistive touch screen into intersecting strips. When a finger or stylus forces an intersecting pair of strips together, a circuit is closed (*i.e.*, the voltage measured between the pair goes from an open-circuit voltage of a few volts to a closed-circuit voltage of zero volts).

In the case of a voltage-sensing in-cell touch screen, micro-switches are added to each pixel to form the switch matrix. When a finger or stylus pressing on the surface of the LCD closes one or more micro-switches, the same voltage measurement is made. In both cases, the controller isolates and drives each column separately such that multiple row circuit closures can be detected on one column without interference from other columns, thus inherently providing multi-touch. A schematic illustration of a voltage-sensing in-cell touch design is provided in Fig. 3.

The advantages of the voltage-sensing form of in-cell touch include the following:

- The relative simplicity of the controller (compared with the much more complex controller required for light-sensing in-cell) potentially allows integration directly into the LCD driver IC.
- The voltage-sensing switch matrix is totally independent of ambient and backlighting.
- A voltage-sensing in-cell touch screen with one sensor per pixel should be optimal for use with a stylus, since subpixel resolution can be achieved by inter-pixel interpolation.

The disadvantages of voltage-sensing in-cell touch include the following:

- A cover glass cannot be used because the surface of the LCD must be depressed in order to actuate the micro-switches. Because the polarizer (top surface) on today’s LCDs typically has a pencil hardness of only 2H or 3H, this is a signifi-

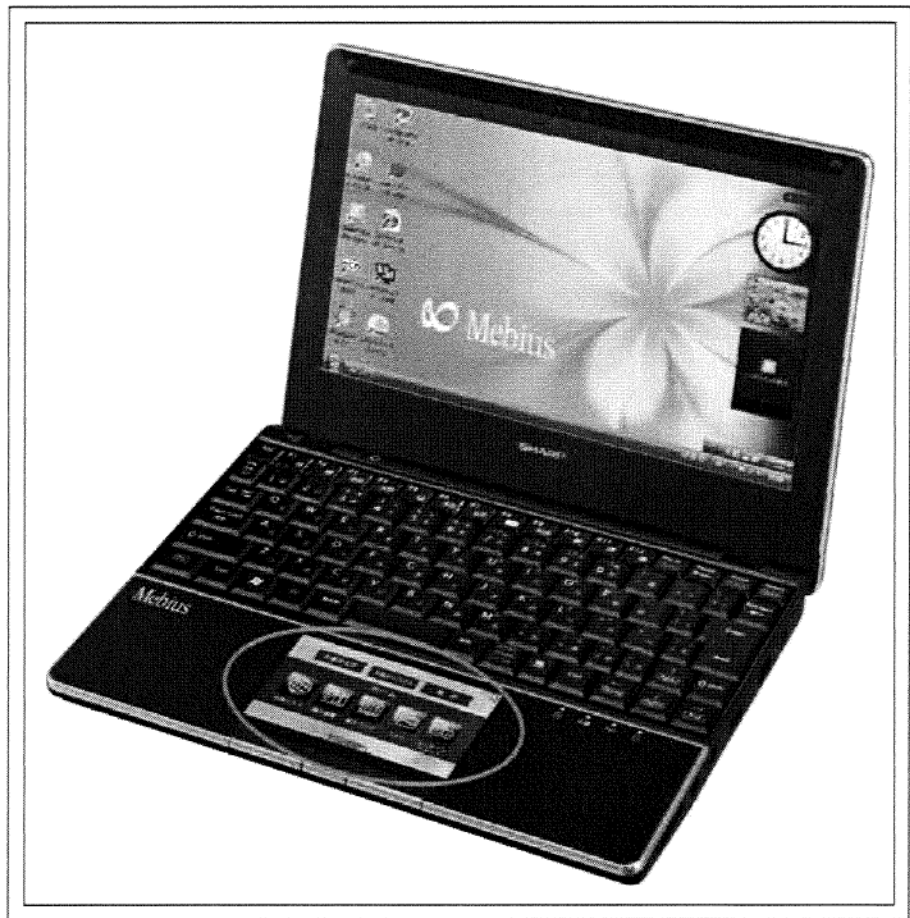

*Fig. 2: Sharp's PC-NJ70A netbook is the first commercial product to use any form of in-cell touch. A light-sensing, in-cell touch screen is integrated in the touchpad LCD, circled in red in the photograph. Source: Sharp.*

cant limitation. For example, AUO's specification on one of its voltage-sensing in-cell touch screens is only 100K touches at less than 40 grams. This is radically less than the typical 30-million/80-gram specification on a five-wire resistive touch screen. While a harder polarizer is an obvious solution to this problem, until there is more demand for touch, the polarizer manufacturers have no motivation to increase hardness and the LCD manufacturers have no motivation to use more expensive, harder polarizers.

- Pressing the surface of most LCDs causes significant liquid-crystal pooling, which is visually distracting. Eliminating the pooling can be accomplished by changing the cell-spacer structure and/or

changing to in-plane switching (IPS), but there are intellectual property (IP), cost, and other restrictions on doing so. Again, until there is more demand for touch, there is little motivation for the LCD manufacturers to make such changes.

- Adding micro-switches decreases the aperture, which makes the LCD less efficient.
- A finite pressure is required to activate the micro-switches, which means that multi-touch gestures can be more difficult to perform than with zero-pressure capacitive touch screens.
- The maximum size of a voltage-sensing in-cell touch screen is limited by the resistive and capacitive (RC) loading of

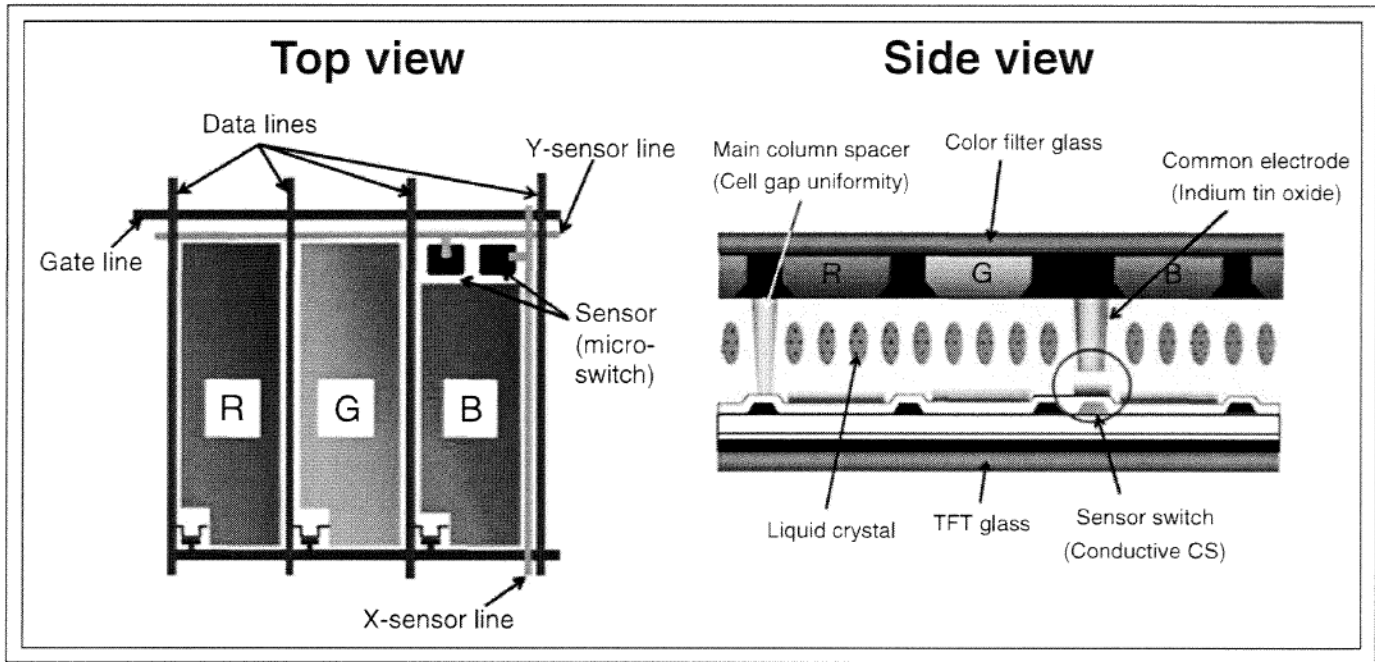

**Fig. 3:** In this schematic illustration of voltage-sensing in-cell touch, two micro-switches are shown occupying a portion of one subpixel in the top view at left. The side view at right shows the implementation of a micro-switch using a conductive column spacer. Source: Samsung.

the connecting traces, as well as by the space required for the traces. Currently, the practical size limit is about 26 in.

Even though there are some significant disadvantages, the advantages of voltage-sensing in-cell touch make it fairly compelling relative to light-sensing in-cell touch. Nevertheless, the number of LCD manufacturers who are working on voltage sensing is the smallest of all three in-cell technologies. The authors are not sure why this is the case; we speculate that it may be due to some IP considerations related to digital-resistive technology.

**Charge Sensing**

Table 2 clearly indicates that charge sensing is currently the most popular of the in-cell touch technologies. The basic reasons are that (a) it is closely related to projected-capacitive touch technology, which has rocketed from obscurity to the number two spot in the touch industry since the launch of the iPhone in 2007 and (b) light-sensing in-cell touch (the former and earliest favorite) has turned out to be much harder to implement than expected.

As previously described, charge sensing is being developed in two forms: in-cell and on-cell. The primary difference between the

two is that in-cell charge sensing relies on a change in capacitance caused by the user pressing on a moveable electrode, while on-cell charge sensing relies on the user's body capacity changing the capacitance between a pair of fixed electrodes.

In the in-cell configuration (Fig. 4), conductive column spacers located on the underneath of the color-filter substrate are added into each pixel or group of pixels. Each spacer has a corresponding conductive electrode on the TFT-array substrate. An electric field is established between each pair of electrodes, which produces a base value of capacitance (stored charge) for each X-Y location. When pressure is applied to the surface of the display with a finger or stylus, the movement of the conductive spacer causes the value of the capacitance between the electrodes to change. This change is measured by a controller and used to determine the location of the touching finger or stylus. Because the conductive spacer is shorter than the main column spacer, the capacitive electrodes cannot contact each other and create a short circuit.

In the on-cell configuration (Fig. 5), two patterned layers of transparent ITO conductors are deposited at right angles to each other

on top of the color-filter substrate (underneath the polarizer) with an insulating layer (dielectric) between them. An electric field is established between the two conductive layers, which creates a base value of capacitance (stored charge) between each X-Y intersection. The capacitance of the human body to ground causes a finger placed on top of the polarizer to change the value of the capacitance between the intersecting electrodes under the finger. This change is measured by a controller and used to determine the location of the touching finger. The number and spacing of the electrodes determines the touch resolution.

While both of these configurations use the same principle of measuring a change in capacitance between transparent electrodes, the controller and the interface it presents to the host system are typically unique to each LCD manufacturer and may even differ between in-cell and on-cell.

The advantages of the charge-sensing form of in-cell and on-cell touch include the following:

- The base technology of determining the location of a touch by measuring changes in small values of capacitance is well-understood and becoming increasingly

common due to the recent extremely rapid growth of projected-capacitive touch.

- Charge-sensing touch is totally independent of ambient lighting or backlighting.
- A thin (typically 0.5 mm) cover glass can be laminated on top of the polarizer to protect the top surface of an LCD with charge-sensing on-cell touch; this is a significant advantage over either charge-sensing in-cell or voltage-sensing in-cell touch.
- Existing color-filter fabs can readily be modified to support manufacturing charge-sensing on-cell touch screens.

The disadvantages of charge-sensing in-cell and on-cell touch include the following:

- Because the capacitance values being measured are very small (typically less than 1 pF), charge-sensing touch is very sensitive to electromagnetic interference. It can be very difficult to make a charge-sensing system work properly, especially as the size of the LCD increases or with noisy LCDs.
- A significant amount of processing power is required in the controller for a charge-sensing touch system. The controller for on-cell charge sensing can be very similar to that for standard projected capacitive, while the controller for in-cell charge sensing has more unique requirements due to the higher level of integration with the LCD.
- The resolution that can be achieved with charge sensing is typically lower than can be achieved with either voltage-sensing or light-sensing in-cell touch. However, this is less significant with on-cell touch because the touch screen can only be activated by a finger (an inherently low-resolution pointing device).
- The conductive spacer electrodes used in in-cell charge sensing can cause some loss of aperture, which reduces efficiency. Similarly, the ITO electrodes used in on-cell charge sensing reduce the transmissivity of the LCD by a few percent, which reduces efficiency.
- The touch object in in-cell charge sensing can only be a finger, which in many applications (e.g., mobile phones in Asia) is a significant limitation.
- In-cell charge sensing will not work with a cover glass, so the LCD can easily be damaged.

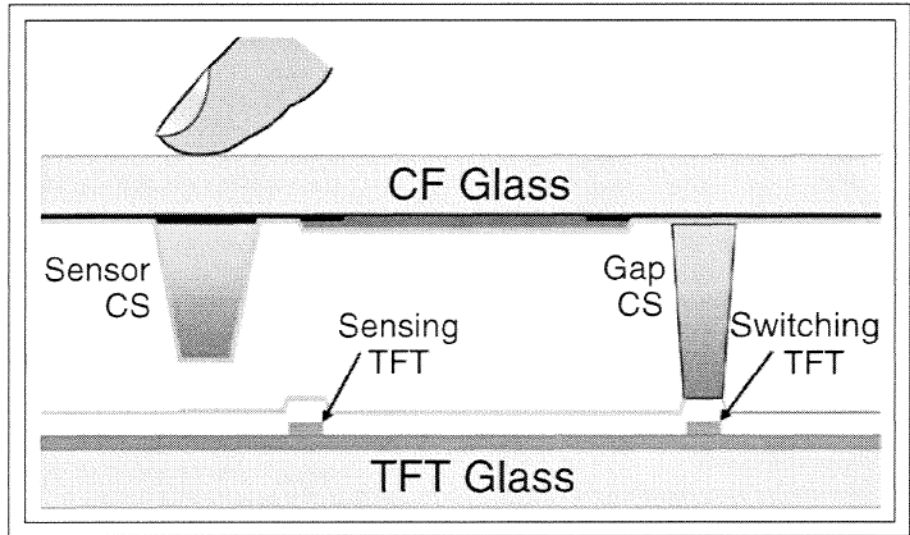

**Fig. 4:** In the in-cell configuration for charge sensing, conductive column spacers for each pixel or group of pixels are located on the underside of the color-filter substrate, and there is a corresponding conductive electrode on the TFT-array substrate. Pressing the surface of the display causes the capacitance between the electrodes to change. Source: LG Display.

- Pressing the surface of most LCDs causes significant liquid-crystal pooling, which is visually distracting. This is most evident when no cover glass is used (in-cell) but the use of a thin cover glass (on-cell) does not completely eliminate the problem.
- The maximum size of a charge-sensing touch screen is limited by the resistive and capacitive (RC) loading of the connecting traces. In-cell charge sensing is also limited by the space required for the traces. Currently, the practical size limit is in the range of 22–24 in.

The only LCD manufacturer who has announced actual available LCD products

using charge-sensing touch is AUO. Sizes include 3.0 and 4.3 in.

#### Technology Comparison

Table 3 presents a comparison of the characteristics of the three in-cell touch technologies. The red-yellow-green ratings (worst, middle, best) are relative within the three in-cell technologies, not within all touch technologies.

#### Opportunities

At least two areas of current research still hold promise for in-cell touch technologies, as follows:

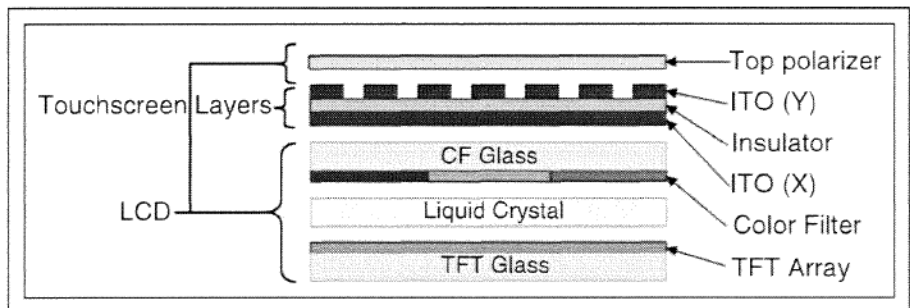

**Fig. 5:** In the on-cell configuration for charge-sensing, the capacitance of the human body to ground causes a finger placed on top of the polarizer (top layer) to change the value of the capacitance between the intersecting electrodes under the finger. Source: Walker and Fihn.

## frontline technology

- Applications such as tablet PCs that benefit from multiple input capabilities (e.g., touch and stylus) may drive solutions that combine multiple in-cell technologies, creating a hybrid technology.
- Recent developments in multi-color subpixel structures may create some interesting opportunities in light-sensing in-cell solutions. An RGBW structure, for example, could enable the photo-transistor to be located in the white subpixel, which would improve sensing performance while reducing some of the shadowing and power-consumption problems.

### Fundamental Issues

Previous sections have described the advantages and disadvantages of each of the three technologies being used in in-cell and on-cell touch. However, there are several higher-level issues that affect the entire in-cell/on-cell touch picture as follows:

- The sensor portion of in-cell touch is almost certain to cost less in terms of

both manufacturing materials and process than conventionally applied touch-screen sensors. (The controller portion may be comparable to that of conventional touch screens.) However, the cost of modifying the backplane and/or front-plane of an existing LCD design to add in-cell touch sensing is at least \$1–2 million, due to masking. Given the very large number of different LCDs that exist, it is unlikely that an LCD manufacturer will make these modifications throughout an entire product line. It is more likely that only selected LCDs used in high-volume products with a high demand for touch will be modified for in-cell touch. In other words, it seems unlikely that in-cell touch is going to become the standard for touch in all LCDs.

- The lack of standards for the interface to in-cell and on-cell touch functionality could be a significant impediment to the spread of the technology in the future. If LCD manufacturers develop their own

unique interfaces to the touch function (which seems to be the case thus far), it will greatly limit the ability of device OEMs to second-source LCDs with in-cell or on-cell touch.

- There is no perfect touch technology: each technology has advantages and disadvantages. This is the reason there are so many different touch technologies. It therefore seems unlikely that the three in-cell/on-cell touch technologies are going to dominate the touch industry and completely eliminate all other technologies.

### Conclusions

Although in-cell touch has been eagerly anticipated for more than 7 years, it still has some distance to go to reach full commercialization. Light-sensing in-cell is probably the furthest away because it has the most unresolved problems. Voltage-sensing in-cell has potential, but there are no announced LCDs or end-user products that incorporate it. Charge-sensing in-cell and on-cell are the closest to commercialization, with a few announced LCDs that will probably ship in mobile phones during 2010. The focus of most of the LCD manufacturers working on in-cell touch is now on mobile displays because sizes larger than 10 in. have proven to be quite difficult and there are no clearly identified high-volume touch applications.

### References

<sup>1</sup>A. Abileah and P. Green, "Optical Sensors Embedded within AMLCD Panel: Design and Applications," *International Conference on Computer Graphics and Interactive Techniques*, ACM SIGGRAPH (2007). ■

**Table 3:** Some of the characteristics of the three technologies being used in in-cell and on-cell touch appear in terms of best (green) to worst (red), with yellow in the middle.

| Characteristic                    | Light Sensing             | Voltage Sensing | Charge Sensing (In-cell) | Charge Sensing (On-cell) |
|-----------------------------------|---------------------------|-----------------|--------------------------|--------------------------|
| Size limit (in.)                  | 20                        | 26              | 22–24                    | 22–24                    |
| Touch object                      | Finger, stylus, light pen | Finger, stylus  | Finger, stylus           | Finger                   |
| Touch force                       | None                      | Some            | Some                     | None                     |
| Touch resolution                  | Medium                    | High            | Low                      | Low                      |
| Cover glass                       | Yes                       | No              | No                       | Yes                      |
| Durability                        | High with cover glass     | Low             | Low                      | High with over glass     |
| True flush surface ("zero bezel") | Yes with cover-glass      | No              | No                       | Yes with cover glass     |
| Transmissivity loss               | Aperture                  | Aperture        | Aperture                 | ITO                      |
| External EMI sensitivity          | None                      | None            | High                     | High                     |
| Internal EMI sensitivity          | High                      | None            | High                     | Medium                   |
| Ambient light sensitivity         | High                      | None            | None                     | None                     |
| Flexible substrate                | Yes                       | No              | No                       | Yes                      |
| Controller complexity             | High                      | Low             | Medium                   | Medium                   |

### Submit Your News Releases

Please send all press releases and new product announcements to:

Jenny Donelan  
*Information Display Magazine*  
 411 Lafayette Street, Suite 201  
 New York, NY 10003  
 Fax: 212.460.5460  
 e-mail: [jdonelan@pcm411.com](mailto:jdonelan@pcm411.com)





Radiance  
Polarization  
88° Viewing cone  
Chromaticity  
Luminance  
Contrast ratio

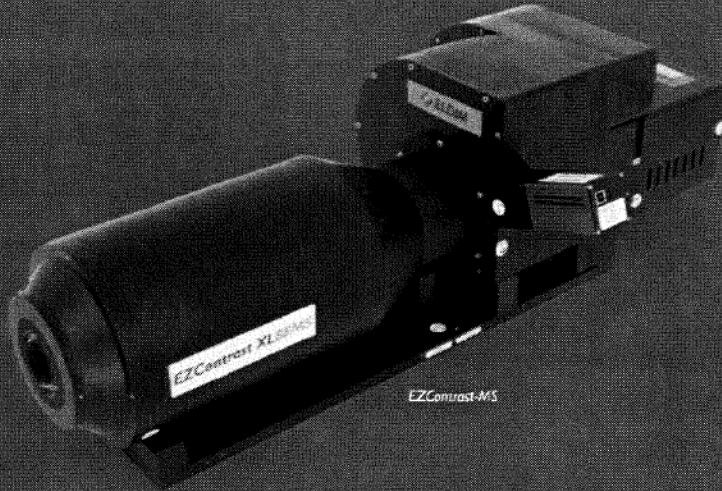

HDTV  
3D displays  
LCDs  
Lighting  
Automotive  
Avionic  
Medical displays

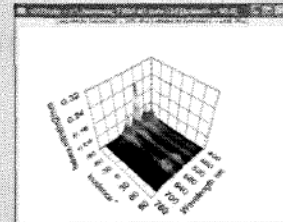
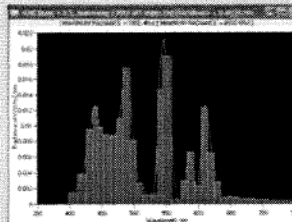
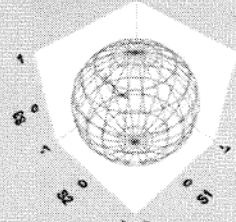
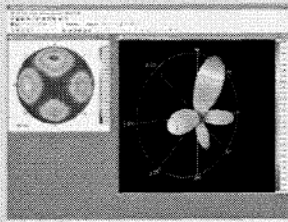

Revolutionary system for full spectral & polarization measurement  
in the entire viewing angle

Phone: +33 2 31 947 600 e-mail: sales@eldim.fr Web: www.eldim.fr

See Us at Display Week 2010 in Seattle

# DISPLAY WEEK 2010

## The SID International Symposium, Seminar & Exhibition



Seattle is famous for technology as well as great food and drink—and of course for its stunning Pacific Northwest location. This exciting, eclectic city is an ideal place for the electronic display community to come together to share inventions and ideas.

Display Week is the once-a-year, can't-miss event for the electronic information-display industry. The exhibition is the premier showcase for global information-display companies and researchers to unveil cutting-edge developments in display technology. More display innovations are introduced year after year at Display Week than at any other display show in the world. Display Week is where the world got its first look at technologies that now shape the display industry, such as: HDTV, LCD, Plasma, DLP, LED, and OLED, to name just a few. First looks like these are why over 6,500 attendees will flock to Seattle for Display Week 2010.

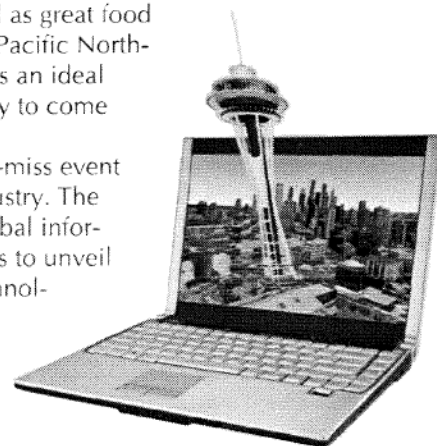

Washington State Convention and Trade Center, Seattle, Washington, U.S.A.  
May 23–28, 2010

# Projected-Capacitive Touch Technology

*Projected-capacitive touch has grown extremely rapidly from obscurity in 2006 to the number-two touch technology in 2009. This article examines all aspects of projected-capacitive touch technology, delving into sensor, controller, and module details.*

by Gary Barrett and Ryomei Omote

**T**HE ADVENT of the iPhone has ushered in a seismic change in the touch-screen business. Projected capacitive (pro-cap), the touch technology used in the iPhone touch screen, has become the first choice for many small-to-medium (<10-in.) touch-equipped products now in development. The technology is not just Apple-trendy but incorporates some of the best characteristics of competing touch technologies.

The three most important advantages of pro-cap technology are as follows:

- High durability (long life)
- Excellent optical performance (high transmissivity)
- Unlimited multi-touch (controller-dependent)

Pro-cap touch screens can be made entirely of plain glass, allowing them to be immune to most chemicals, operated in extreme temperatures, and sealed to meet the requirements for most wash-down and explosive environments. Pro-cap touch screens can also be made entirely of plastic, allowing them to be virtually unbreakable and have the flexibility to be contoured or bent. The sensing range of pro-cap touch screens can be extended, allow-

ing them to be used with cotton or surgical gloves. Pro-cap touch-screens have the capability of sensing as many fingers as can fit on the screen.

The three major disadvantages of pro-cap technology are as follows:

- Difficulty of integration (noise sensitivity)
- Finger-touch only (although this may be changing)
- Relatively high cost (dropping rapidly)

Because they must sense changes in capacitance as small as a few femtofarads ( $10^{-15}$  F), pro-cap touch screens are very sensitive to electromagnetic interference (EMI). This makes integration challenging, particularly when the touch screen is bonded to an LCD, and also makes screens larger than about 22 in. (diagonal) very difficult to build. Pro-cap touch screens rely on human-body capacitance to cause a touch to be recognized, so they currently require a human as the touch object. Finally, a typical smartphone pro-cap touch screen (3.5 in.) is currently about three times more expensive than its analog-resistive equivalent – although that difference could drop by half in as little as 2 years.

## How Capacitive Sensing Works

Capacitive sensing is a very old technology. Mature readers may remember novel room lamps that could be turned on by touching a growing plant, and every reader has probably used capacitive elevator buttons at least once in his or her life. These primitive capacitive-sensing applications typically used a solid-state timer (such as an NE555 integrated

circuit, first available in 1971) that “clicked” at a steady rate as determined by the time constant of an external resistor-capacitor (RC) network. A microcontroller was then programmed to monitor the clicks from the timer and when the rate increased or decreased, it would react. A wire (or piece of ivy, in the case of the novel lamp) was routed to a touch point and when a human touched it, additional body capacitance was added to the RC network which, in turn, altered the click rate and caused a touch to be detected (see Fig. 1). Now, over 30 years later, the same function is typically accomplished by using a simple capacitive switch IC.

## Self-Capacitance

The type of pro-cap described above is called “self-capacitance” because it is based on measuring the capacitance of a single electrode with respect to ground. When a finger is near the electrode, the human-body capacitance changes the self-capacitance of the electrode.

In a self-capacitance touch screen, transparent conductors are patterned into spatially separated electrodes in either a single layer or two layers. When the electrodes are in a single layer, each electrode represents a different touch coordinate pair and is connected individually to a controller. When the electrodes are in two layers, they are usually arranged in a layer of rows and a layer of columns; the intersections of each row and column represent unique touch coordinate pairs. However, self-capacitance touch-screen controllers do not measure each intersection; they only measure each row and column; *i.e.*, each indi-

*Gary Barrett is the Chief Technology Officer at Touch International. He can be reached at 512/832-8292 or gbarrett@touchintl.com. Ryomei Omote is the General Manager of the Sensor Module Engineering, Industrial Materials and Input Device Business Unit at Nissha Printing. He can be contacted at +81-75-823-5271 or r-omote@nissha.co.jp.*

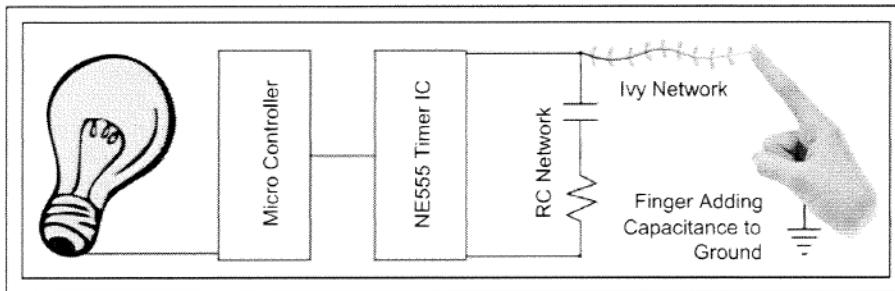

**Fig. 1:** Capacitive sensing is a very old technology. This schematic shows how a 1970s-era capacitive-sensing lamp could be turned on by touching a panel. It functioned by using body capacity to change the click rate of a timer. Source: Barrett and Omote.

vidual electrode. This works well when only a single finger is touching the screen. For example, in Fig. 2, a single-finger touching location X2,Y0 can be sensed accurately by measuring all the X electrodes and then all the Y electrodes in sequence.

Measuring individual electrodes rather than electrode intersections is the source of one of the major disadvantages of two-layer self-capacitance touch screens – the inability to unambiguously detect more than one touch. As shown in Fig. 2, two fingers touching in locations X2,Y0 and X1,Y3 produce four reported touch points. However, this disadvantage does not eliminate the use of two-finger gestures with a self-capacitance touch screen. The secret is in software – rather than using the ambiguous locations of the reported points, software can use the direction of movement of the points. In this situation it does not matter that four points resulted from two touches; as long as pairs are moving away from or toward each other (for example), a zoom gesture can be recognized.

### Mutual Capacitance

The other more common type of pro-cap today is “mutual capacitance,” which allows an unlimited number of unambiguous touches, produces higher resolution, is less sensitive to EMI, and can be more efficient in its use of sensor space. Mutual capacitance makes use of the fact that most conductive objects are able to hold a charge if they are very close together. If another conductive object, such as a finger, comes close to two conductive objects, the charge field (capacitance) between the two objects changes because the human-body capacitance “steals” some of the charge.

In a mutual-capacitance touch screen, transparent conductors are always patterned into

spatially separated electrodes in two layers, usually arranged as rows and columns. Because the intersections of each row and column produce unique touch-coordinate pairs, the controller in a mutual-capacitance touch screen measures each intersection individually (see Fig. 3). This produces one of the major advantages of mutual-capacitance touch screens – the ability to sense a touch at every electrode intersection on the screen.

Because both self-capacitance and mutual-capacitance rely on the transfer of charge

between human-body capacitance and either a single electrode or a pair of electrodes, this method of capacitive sensing is most commonly called “charge transfer.” Table 1 compares the key characteristics of self-capacitance and mutual-capacitance as applied in touch screens.

### Scanning

Pro-cap touch screens are “scanned,” meaning that each individual electrode or electrode intersection is measured one-by-one in an endless cycle. Self-capacitance touch screens are scanned using a straightforward serial method because every electrode is connected individually to the controller. Mutual-capacitance touch screens, on the other hand, require a more-complex scanning mechanism that measures the capacitance at each row and column intersection. In this type of scan, often called “all points addressable,” the controller drives a single column (Y) and then scans every row (X) that intersects with that column, measuring the capacitance value at each X-Y intersection. This process is repeated for every column and then the entire cycle starts over. This makes a mutual-capac-

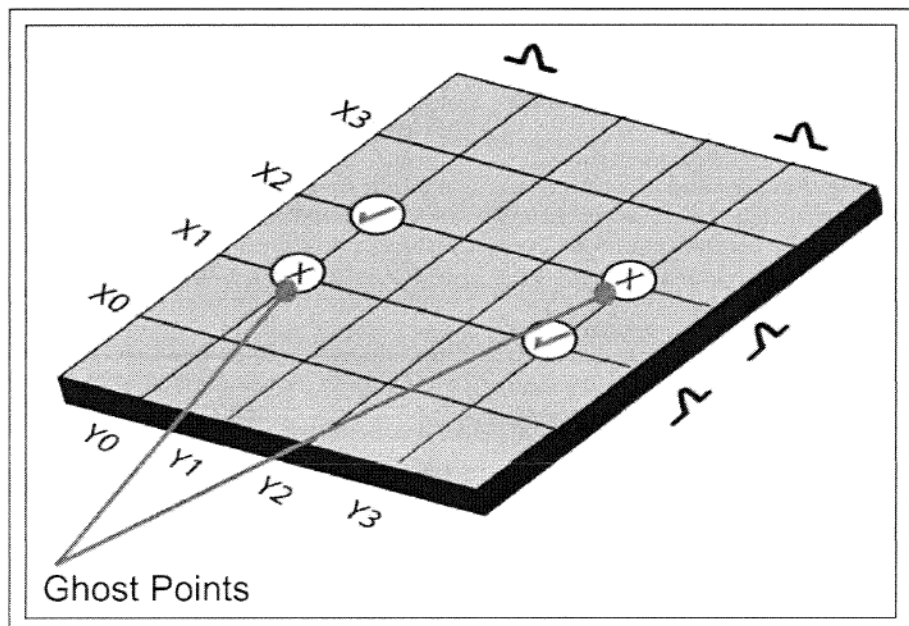

**Fig. 2:** When a self-capacitance touch screen is touched with two fingers that are diagonally separated, a pair of “ghost points” are created because the controller only knows that two columns and two rows have been touched; it cannot tell which coordinate pairs belong together because it is only scanning individual electrodes, not electrode intersections. Source: Barrett and Omote.

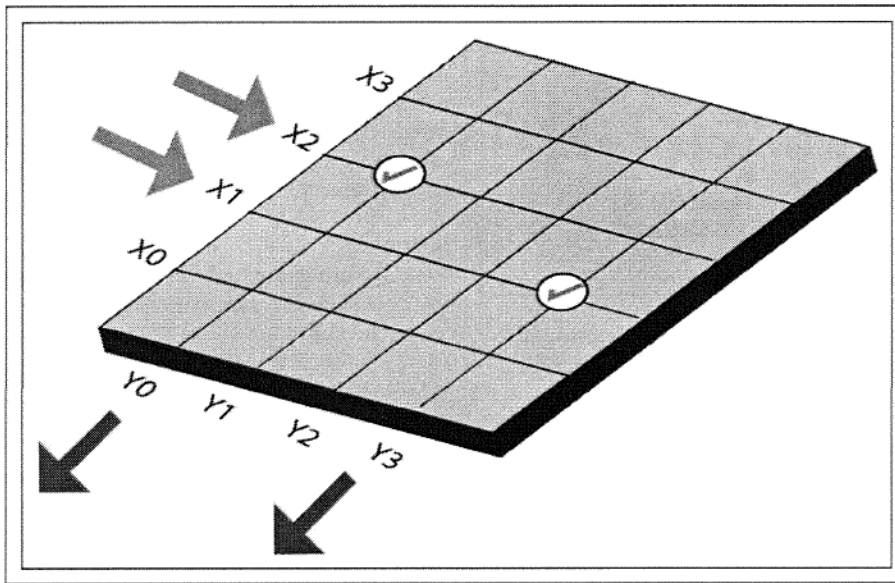

Fig. 3: In a mutual-capacitance touch screen, every electrode intersection can be unambiguously identified as a touch point. Source: Barrett and Omote.

itance controller relatively complex with a high processor load, but, in return, it supports unlimited multi-touch. Scanning rates in current pro-cap controllers range from approximately 20 to 200 Hz; a typical smartphone touch screen may have nine columns and 16 rows, for a total of 25 electrodes and 144 electrode intersections.

In both types of pro-cap touch screens, to determine an exact touch location, the values from multiple adjacent electrodes or electrode intersections are used to interpolate the exact touch coordinates. The results are extremely precise and the resolution is usually at least  $1024 \times 1024$  (10 bits). Scanning also has the advantage of being free of coordinate drift. This is possible because the rows and columns are physically fixed and each measurement is made in a small area. Without the issue of coordinate drift, pro-cap touch screens do not have to be calibrated by the end-user as long as the touch screen is securely attached to the display.

**Touch-Screen Construction**

In the short time since the introduction of pro-cap touch screens in iPhones, a myriad of construction methods have been developed. All pro-cap touch-screen designs have two key features in common: (1) the sensing mechanism is underneath the touch surface and (2) there are no moving parts. The most common

design incorporates the simple concept shown in Fig. 4.

Some of the newest products under development use a single-sided design, where all of the touch screen’s layers are on one side of a single substrate. In this design, currently the thinnest possible for pro-cap, all of the layers are deposited by sputtering. There are innumerable variations on the basic design of the two-layer pro-cap shown in Fig. 4. For instance, micro-fine (10  $\mu\text{m}$ ) wires can be substituted for the sputtered ITO. Many mobile phones and most current signature-capture terminals use ITO on separate sheets of PET

for each of the layers. Also common are touch screens that use one two-sided or two one-sided ITO-coated sheets of glass.

**Touch-Screen Conductors**

Patterning ITO on glass with line widths of 20  $\mu\text{m}$  and resistivity of  $150 \Omega/\square$  is commonly accomplished using photolithographic methods; for example, using photoresist on an LCD fab. When the substrate is PET, line widths are typically 100–200  $\mu\text{m}$  and patterning is accomplished using screen-printing, photolithography, or laser ablation. Research is in progress on fine-line patterning on PET with line widths of 30–50  $\mu\text{m}$ . When used, the third unpatterned LCD shield layer typically has a resistivity of  $150\text{--}300 \Omega/\square$ . Standard-width (not narrow-border) signal lines at the edge of the sensor are typically constructed of a molybdenum/aluminum/molybdenum combination.

**Touch-Screen Conductor Patterns**

ITO layers in pro-cap touch screens can be etched in several different patterns, all of which cost the same to manufacture, and it is difficult to say that one pattern outperforms another since touch-screen sensors and controller electronics are highly interrelated.

The pattern used in the original iPhone is one of the simplest, consisting of 10 columns of 1-mm-wide ITO spaced 5 mm apart on one side of a sheet of glass and 15 rows of 5-mm-high ITO with 37- $\mu\text{m}$  deletions between them. The space between the 10 columns is filled with unconnected (floating) ITO in order to maintain uniform optical appearance. This design works well, but the geometry requires substantial processing power to generate accurate coordinates.

**Table 1:** A comparison of the key characteristics of self-capacitance and mutual-capacitance as applied in touch screens.

| Characteristic   | Self-Capacitance                     | Mutual Capacitance   |
|------------------|--------------------------------------|--|
| Electrode types  | Sensing only                         | Driving & sensing  |
| Number of layers | 1 or 2                               | 2  |
| Sensor design    | Multi-pad or row & column            | Any design with unique electrode intersections; usually row & column |
| Scanning method  | Each electrode individually          | Each electrode intersection  |
| Measurement      | Capacitance of electrode to ground   | Capacitance between electrodes                                       |
| Ghost points     | No in multi-pad; Yes in row & column | No   |

The most common pattern is an interlocking diamond that consists of squares on a 45° axis, connected at two corners via a small bridge. This pattern is typically applied in two layers – one layer of horizontal diamond rows and one layer of vertical diamond columns (see Fig. 5). Each layer adheres to one side of two pieces of glass or PET, which are then combined, interlocking the diamond rows and columns. The diamond size varies by manufacturer but is in the range of 4–8 mm; almost all pro-cap controllers work with the diamond pattern.

### Border Area

One of the most important cost drivers in pro-cap touch-screen design is the border area. Unlike conventional analog-resistive touch screens, which have only four or five signal lines, pro-cap touch screens often have 40 or more connections because each row and column must be connected to the controller (or to an intermediate capacitive-to-digital signal-processing chip). This can require a significant border area around the touch-screen active area. Historically, connection traces have been silk-screen printed 1 mm wide with a 1-mm gap using silver inks.

The latest mobile phones always require a narrow border. To achieve this, a technique similar to that utilized for TFT-LCDs is used. This technique requires the touch screen to be sputtered and etched to add multiple layers of thin films in the border area, which adds cost. Fine-line silver printing with 50–100-µm lines and gaps achieves a lower cost than the sputtering technique, but polyimide tails remain the most common method of attaching to the lines, which requires the material to protrude beyond the edge of the substrate and is also expensive.

Cost can be reduced substantially if a device does not require flush mounting and can allow for a larger border area under the bezel.

### Cover Lens and Touch Surface

Mobile-phone touch screens typically use a plastic or glass “cover lens” that is laminated to the touch screen. This allows product designers to make the touch screen flush with the top surface of the device housing (as in the iPhone). The cover lens can be screen-printed on the rear surface, in-mold decorated (IMD), or, more commonly, a decorated film can be laminated to the rear surface. The decoration hides the touch-panel circuitry, incorporates a logo, can have ruby coatings for a camera, and can act as a diffuser for backlights. A glass

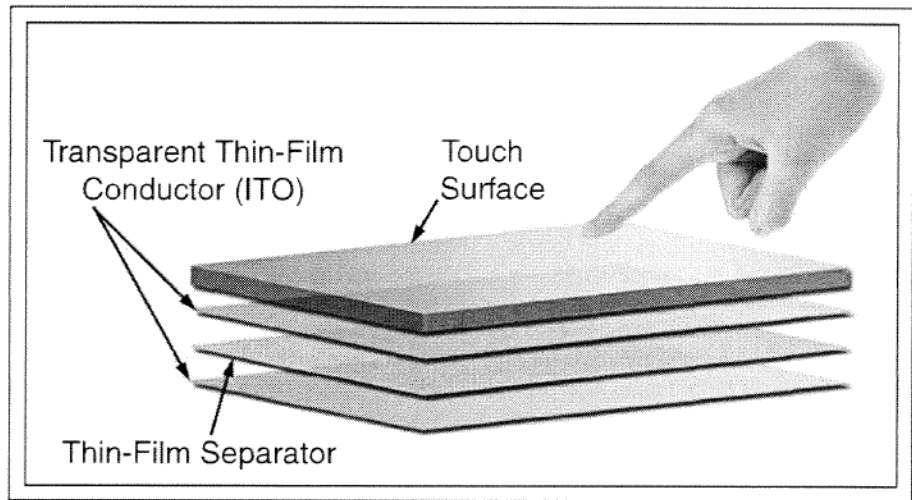

**Fig. 4:** The pro-cap design concept shows two transparent conductor layers separated by an insulator, all under the touch surface. (Note that the transparent conductors are shown as solid sheets when in fact they are actually patterned.) In some cases, an additional unpatterned ITO layer is added at the bottom of the stack as a shield for LCD noise. Source: Barrett and Omote.

cover lens is typically 0.55, 0.75, or 1.1 mm thick for mobile devices and up to 3 mm thick for kiosk applications. The dielectric constant of the cover lens and its thickness have a direct bearing on the sensitivity of the pro-cap touch screen – a thinner cover lens and/or a higher dielectric constant results in better performance. Plastic (PMMA) can be used in place of glass; however, it has a lower dielectric constant and must be half the thickness of glass to achieve the same performance.

When glass is used for the cover lens, some designers choose to chemically strengthen it to reduce the chance of breaking. Float glass (soda-lime) or aluminum silicate are the most commonly used types of glass. Chemically strengthened float glass is half as likely to break

as plain float glass: chemically strengthened aluminum silicate is less than one-third as likely to break. Some cover-lens designs have become extremely complex with multiple holes and slots, rounded corners, and even bent edges. All of these processes must be performed before the glass is chemically strengthened.

### Curved Substrates

As the industrial design of consumer products has become a bigger factor in the purchasing decision, curved substrates have become very important. Pro-cap is one of the few touch technologies that allows the sensor to be curved. Two-dimensional surfaces are straightforward to produce by sputtering ITO on polycarbonate or some other film and then

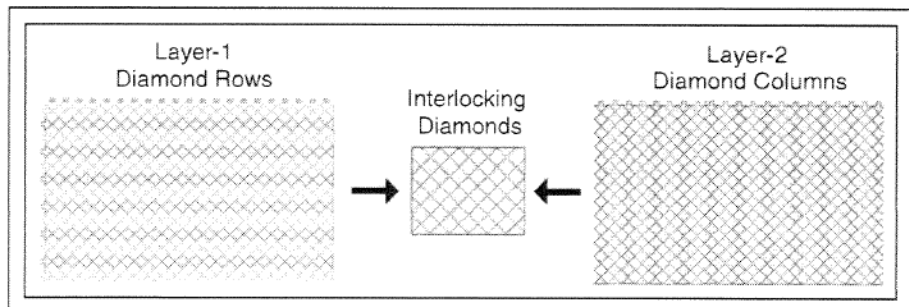

**Fig. 5:** The diamond pro-cap sensor pattern is formed by two interlocking diamond-shaped layers. Source: Barrett and Omote.

## frontline technology

putting the film into the cover-lens mold. Three-dimensional (3-D) surfaces are more challenging: one solution under development uses a molded or flexible substrate and elastic conductive material such as PEDOT.

### Controller Designs

There are approximately 17 vendors selling pro-cap controllers today, several of whom offer both self-capacitance (one or two touches) and mutual-capacitance (unlimited multi-touch) types. Mutual capacitance is fast becoming the standard because of the strong market momentum toward multi-touch driven by the Apple iPhone and Windows 7. Available pro-cap controllers range from dedicated controllers that are specific to a particular sensor size and row-column configuration, to fully programmable microcontrollers with advanced built-in gesture-recognition capabilities. Current controllers are limited to a maximum sensor size of around 10 in. at best; however, most controllers can be combined to support larger sensors. At least one controller supplier has announced that it is developing single-chip controllers that can support sensors up to 17 in. Figure 6 illustrates a typical controller implementation in a mobile phone.

Historically, pro-cap has always been finger-touch only; it has supported only electrically tethered pens (which are highly desirable on signature-capture terminals!). This has been a relatively significant shortcoming of the technology, particularly with mobile phones in Asia, where users often write Kanji characters on their resistive-touch-screen-equipped phones. In 2009, Atmel announced its pro-cap controller's ability to respond to a conductive stylus; this resulted from the 3× increase in signal-to-noise (S/N) ratio it was able to achieve (from 25:1 to 80:1). The limitation is that the stylus tip diameter must be 2–3 mm, which is considerably larger than the typical 0.8-mm PDA/smartphone stylus-tip diameter. The market acceptance of this stylus size is still to be determined.

Another attribute of pro-cap technology is that the touch screen does not actually have to be touched to be activated. The touch screen's level of sensitivity can be controlled by the electronics. In most cases, software is designed to require a physical touch to activate a function. However, the sensitivity can be increased so that the simple placement of a hand near the touch screen (in the Z-axis) can be detected. This is commonly called "proximity sensing."

The selection of a controller vendor typically depends on two factors – performance specifications and the maturity and sophistication of the customer. Some vendors are more oriented toward proposing a total solution for inexperienced customers (device OEMs), which naturally results in less flexibility. Some controller vendors work mainly with sensor manufacturers, who, in turn, work with the device OEMs. Other controller vendors work mainly directly with the device OEMs. The most important controller performance specifications include power consumption, scan speed, maximum number of touches, capacitance-measurement sensitivity, and chip size. The standard hardware interface for mobile-phone controllers is I<sup>2</sup>C; the standard interface for PC controllers is USB.

### Controller Firmware

Controller firmware (especially algorithms) is evolving very rapidly in the pro-cap touch-screen industry, much faster than sensor or controller hardware.

Conventionally, touch controllers have generated only one X-Y coordinate pair. With pro-cap, controllers must now be capable of generating at least two pairs and often up to 10 or more pairs. In small-to-medium (<10-in.) devices, the output format of the coordinate data varies depending on the controller supplier. In large-area (>10-in.) devices, Windows 7 has now established a coordinate data-format standard to which most controllers capable of supporting large-area screens are expected to adhere. Microsoft has also established a standard (part of the Windows 7 Touch Logo specification) on the minimum number of points per second per touch (50) that a multi-touch controller must deliver.

### Number of Touches

How many touches are enough? On one hand, some industry participants believe that two touches on a mobile phone are enough; tablets and netbooks/notebooks used in gaming may require four touches and PCs with 15-in. or larger screens may require 10 touches. Windows 7 supports up to 100 touches. The reality is that today, other than multi-player games, there are very few applications that make use of more than two touches. Other than observing that all humans have 10 fingers, nobody seems to have any clear concept of how real-world applications will use that many touches.

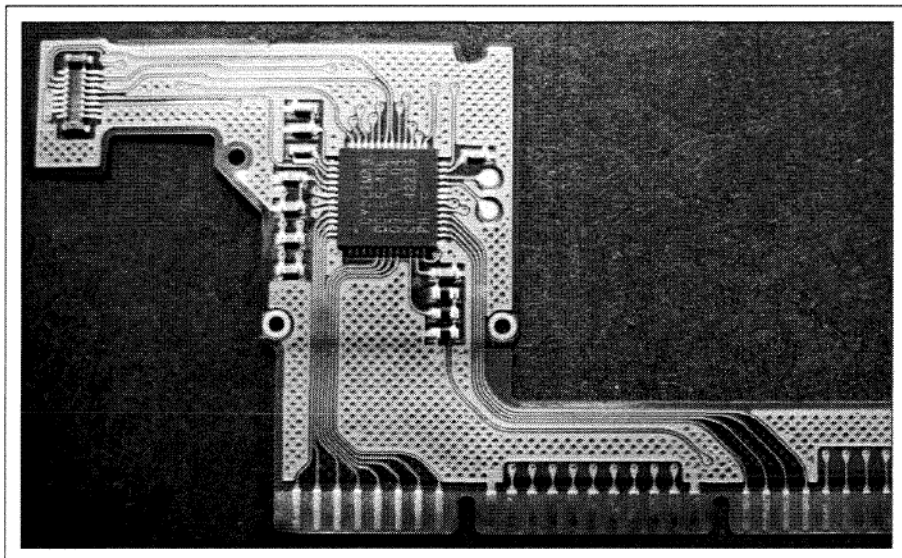

**Fig. 6:** Most pro-cap controller implementations are on the touch-screen tail, located close to the sensor to minimize noise pickup. This photo shows an example of a touch-screen tail from a mobile phone. The controller is a PSoc chip from Cypress Semiconductor. The 25 pins along the lower edge of the tail connect to the sensor (nine columns plus two grounds in the middle; 16 rows split into two groups of eight on the left and right). The connector in the upper-left corner of the tail connects to the phone's main board. Source: Nissha Printing.

On the other hand, it is clear that as the border width gets ever smaller on mobile devices, touch screens must reject the unwanted touches caused by fingers holding the device (*i.e.*, “grip suppression”). Apple’s patent application on the iPhone pro-cap touch screen<sup>1</sup> says that the controller is designed to support up to 15 touches for this purpose, consisting of “10 fingers, 2 palms, and 3 others.” Related to this, many controllers are capable of sending a message indicating when a large number of locations are being activated at the same time. On mobile phones, this attribute is often used to determine that the phone is next to the face or the device has been put away in a pocket, signaling that all touches should be ignored.

### Business Model

There are at least 36 suppliers in the pro-cap touch-screen industry today. Table 2 below lists some of the leading suppliers. Relatively few of them are currently capable of supplying modules (integrated sensor and controller assemblies); some examples include Cypress, ELAN, Melfas, N-trig, Nissha, Synaptics, Wacom, and Zytronic. The remainder of the 36 is split more or less evenly between sensor and controller suppliers. Some of these have ambitions to become module suppliers because (theoretically) it is easier for module

**Table 2:** Each of the leading suppliers in the pro-cap touch-screen industry listed below has shipped more than 1 million units.

| Sensors                    | Controllers | Modules         |
|----------------------------|-------------|-----------------|
| Cando                      | Atmel       | N-trig          |
| DigiTech Systems           | Broadcom    | Nissha Printing |
| EELY                       | Cirque      | Synaptics       |
| Inmolux                    | Cypress     | Wacom           |
| JTtouch                    | EETI        | Zytronic        |
| Nanjing Wally              | ELAN        |                 |
| Nissha Printing            | Melfas      |                 |
| Touch International        | Pixcir      |                 |
| TPK Solutions              | Synaptics   |                 |
| Wintek                     |             |                 |
| Young Fast Optoelectronics |             |                 |

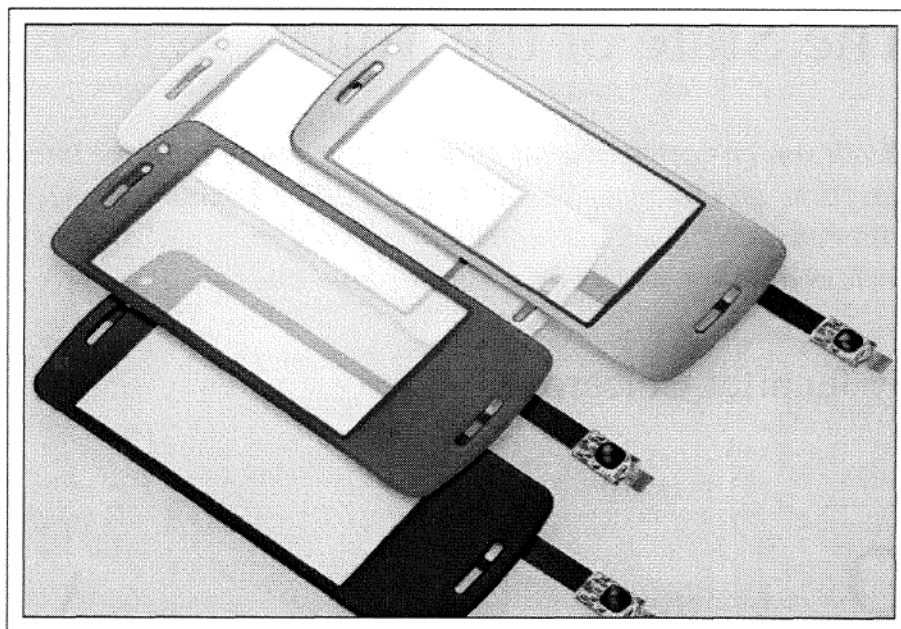

**Fig. 7:** Smartphone pro-cap touch-screen modules manufactured by Nissha Printing consist of a pro-cap sensor, a decorated cover lens laminated to the sensor and a controller mounted on the FPC (flexible printed circuit) that makes up the touch-screen connector tail. Source: Nissha Printing.

makers to support their complete product, and the margin is higher. However, becoming a module supplier can be challenging. It requires a high level of expertise in EMI engineering, the ability to modify the firmware of any controller used in the module (in order to achieve uniformity of input across controllers), knowledge of and ability to support any OS with which the module is used, and module manufacturing expertise. Figure 7 shows some representative modules manufactured by Nissha Printing.

Device OEMs today want more module suppliers because that makes their job easier. But this may be the case only for a few years. If pro-cap touch becomes as popular as analog-resistive touch, then the device OEMs will probably want to buy the controller with software themselves and buy the sensor separately. In other words, the market may evolve into a more standardized commodity market. This is of course worrisome to potential module suppliers.

### Summary

In the last 3 years, pro-cap has grown extremely rapidly to become the number-two touch technology. Pro-cap is used in two

forms, self-capacitance and mutual-capacitance; only the latter supports unlimited multi-touch. Many different construction methods are used, the most common one today is multiple sputtered layers on one side of a substrate. The most common pattern used for the sensor’s transparent conductors is an interlocking diamond. Achieving narrow borders contributes substantially to the cost of a pro-cap touch screen. The design of a plastic or glass cover lens has become an important part of pro-cap touch screens used in mobile devices. Pro-cap controller hardware and firmware are evolving rapidly; the latest generation supports the use of a conductive stylus with a 2–3-mm tip. While very few applications today make use of more than two touches, mobile devices can make use of additional touches in providing “grip suppression.” Some current pro-cap sensor and controller suppliers would like to become module suppliers, but doing so requires a significant investment in additional expertise.

### References

<sup>1</sup>United State Patent Application 2006/0097991. ■

# The State of the Touch-Screen Market in 2010

*Touch screens are in widespread use, due to the intuitive interfaces they enable, which can save time and increase productivity. Falling component prices have also spurred adoption, with consumer products increasingly being designed around touch screens. Touch-screen devices are also widely perceived as cool and fun.*

by Jennifer Colegrove

ONE OF THE DIFFERENCES between the touch-screen market and the display market is the relative degree of consolidation. The display market has consolidated to the point where the top 10 suppliers account for over 90% of total display revenue, while the touch-screen market, by comparison, is made up of around 170 suppliers, with the top 10 accounting for less than 50% of the total market revenue. In other words, the touch-screen market is highly fragmented.

There is also a significant geographic difference between the touch-screen market and the display market. The top 10 display suppliers mentioned above are concentrated in only three countries – Taiwan, Korea, and Japan, while the 170+ touch-screen suppliers are spread across more than a dozen countries (see Fig. 1).

Historically, the touch industry has been centered in Japan and the U.S., but over the past several years there has been rapid growth in Taiwan, China, and Korea.

Long used in industrial equipment, kiosks, and other non-consumer products, touch screens have rapidly been penetrating areas such as mobile phones, portable navigation devices, gaming, and other applications. Over the next several years, touch screens will undergo strong growth in large-size (>10-in.)

*Jennifer Colegrove is Director of Display Technologies at DisplaySearch. She can be reached at [jenny\\_colegrove@displaysearch.com](mailto:jenny_colegrove@displaysearch.com).*

applications such as retail, ticketing, point of information, and education/training.

Among the 20 touch-screen application categories that DisplaySearch tracks, the mobile-phone category is forecasted to be the

largest in terms of shipments and revenues during 2009–2015. There were about 220 million touch screens shipped in mobile-phone applications in 2008, which is a 16% penetration rate. DisplaySearch forecasts that

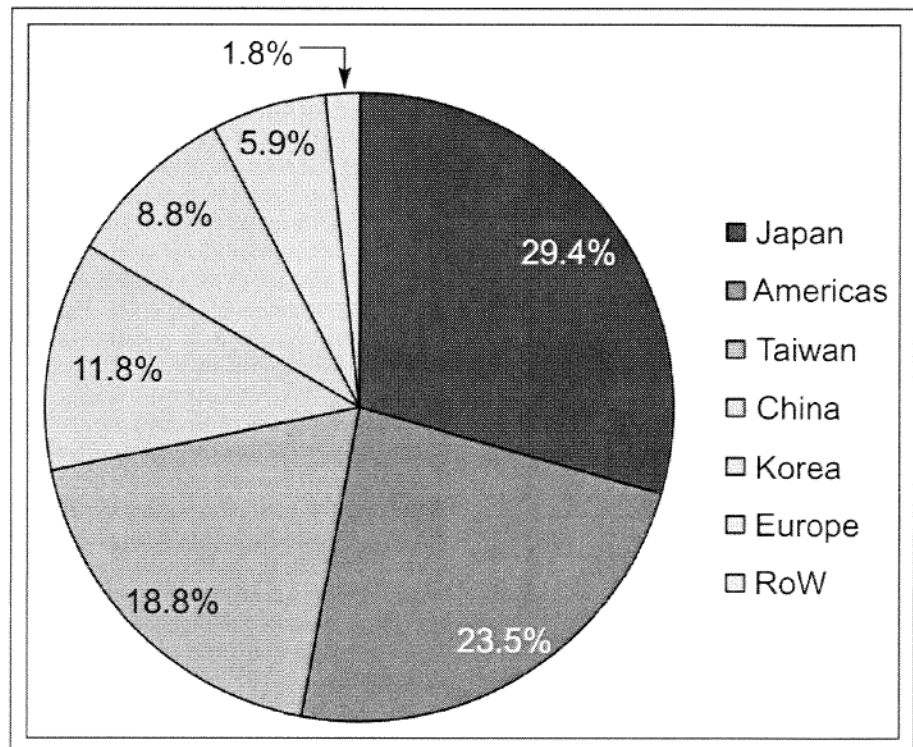

**Fig. 1:** The geographic distribution of touch-screen suppliers shows Japan with the highest percentage. Source: DisplaySearch 2009 Touch Panel Market Analysis Report.



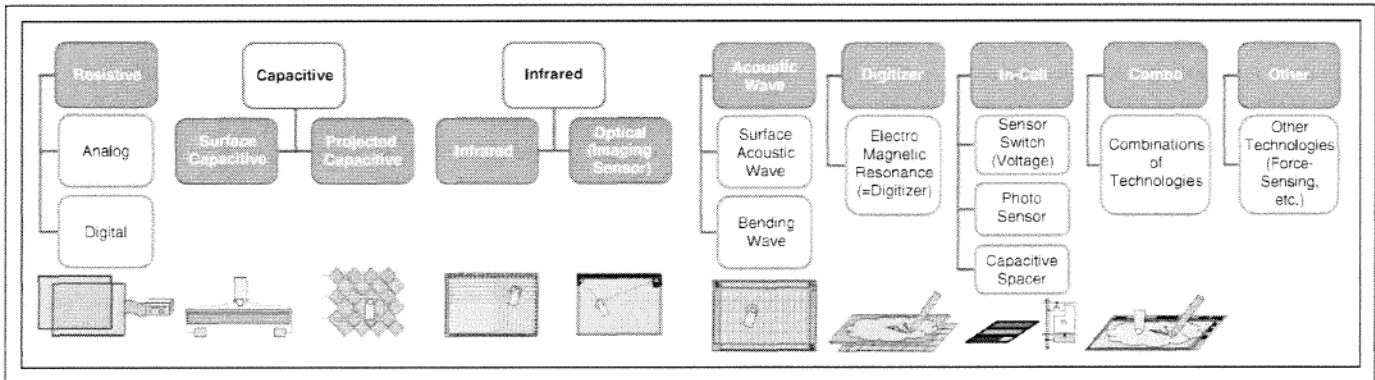

Fig. 2: DisplaySearch divides touch into ten categories with 14 sub-technologies. Source: DisplaySearch 2009 Touch Panel Market Analysis.

the penetration rate of touch in mobile phones will reach nearly 40% by 2015. Other large applications in terms of revenues are vertical markets such as retail and point-of-sales (POS), factory/industry automation, point-of-information (POI), and self-check-in, as well as growing consumer markets for notebook PCs and PMP/MP3 players.

There are over a dozen touch-screen technologies in use, and no single technology can meet 100% of the requirements for every application. As a result, there has been an accelerated stream of innovations in touch-screen technologies in the last few years.

As shown in Fig. 2, DisplaySearch groups touch technologies into ten categories: resistive (both analog and digital), surface capacitive, projected capacitive, infrared (traditional infrared), optical imaging (camera-based), acoustic wave {both surface-acoustic-wave (SAW) and bending-wave [acoustic pulse recognition (APR) and dispersive signal technology (DST)]}, digitizer, in-cell, combination, and others.

One of the more interesting variables in the touch industry is the number of suppliers for each touch technology. There are over 60 companies supplying resistive touch screens, over 30 companies supplying projected capacitive, and over 20 companies supplying surface capacitive.

A significant number of companies support only a single touch technology, a smaller number support two, and very few support three or more, such as 3M and Elo Touch-Systems/Tyco Electronics.

### Market Outlook

The combination of the rapid popularization

of projected-capacitive touch technology and the widespread adoption of multi-touch capability is having profound effects on the consumer portion of the touch-screen market. DisplaySearch forecasts that the unit shipments of touch modules (defined as the combination of a touch sensor and a controller) will grow at a compound annual growth rate (CAGR) of 17% to 1.4 billion units by 2015, more than three times faster than the display market (Fig. 3). Similarly, touch-module revenues are expected to grow at a CAGR of 14% to \$9 billion in 2015, which is over 10 times faster than the display market.

The market for touch screens is relatively small compared with the display market (\$3.7 billion vs. \$90 billion in 2009), but its growth rate is much faster.

### Innovations and Changes in the Touch-Screen Market

The touch-screen industry is a rapidly changing industry, but not all of the touch-screen technologies have experienced the same degree of innovation and change; the following sections discuss the ones with the most significant changes.

**Projected Capacitive:** Projected-capacitive touch has grown very fast in the last few years

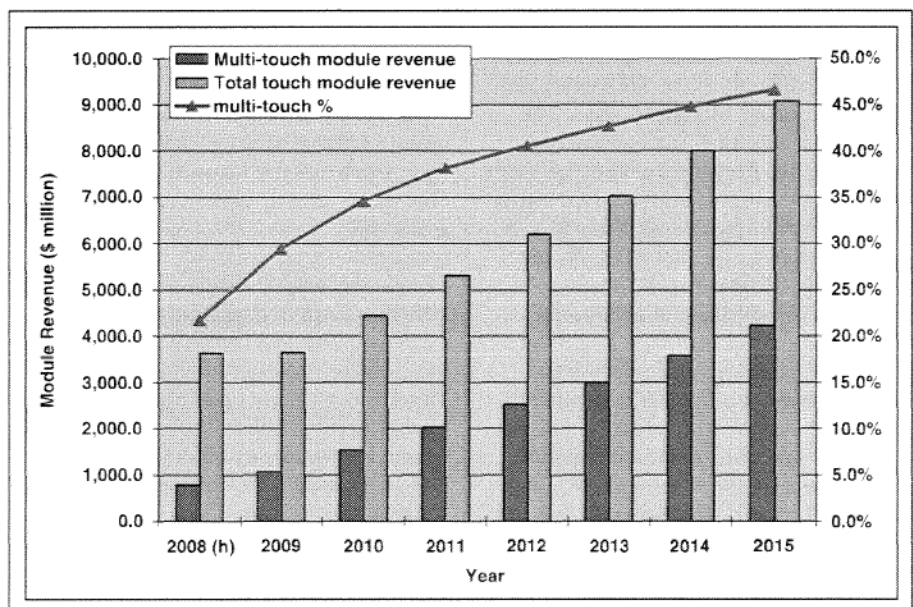

Fig. 3: DisplaySearch's worldwide touch-screen revenue forecast shows total revenues topping \$9 billion by 2015. Source: DisplaySearch 2009 Touch Panel Market Analysis Report.

## display marketplace

since it was first popularized by Apple's iPhone and iPod Touch starting in 2007. Projected capacitive is the first serious challenger to the long-term dominance of analog resistive in the touch-screen world. Not only have more resistive touch-screen manufacturers moved to produce projected capacitive, but projected-capacitive technology has evolved to the use of a single substrate (the ITO coating layers are on one substrate). In recent years, film-based projected capacitive made with micro-fine wire has become available in very large sizes of more than 100 in. At the Consumer Electronics Show in January 2010, there was an astonishing range of products using projected-capacitive touch screens. Projected capacitive is now the number two touch-screen technology and, as such, is attracting large numbers of new competitors into the market. (See the Frontline Technology article, "Projective-Capacitive Touch Technology," in this issue for more details on the technology.)

**Multi-Touch Resistive:** Multi-touch resistive first appeared in the marketplace in shippable form in 2009. Although the technology had been used in a commercial product (a music controller from JazzMutant, now a division of Stantum) since 2004, it only came into prominence when projected capacitive became significant. (For more on this product, see "Developing the First Commercial Product that Uses Multi-Touch Technology," in the December 2007 issue of *Information Display*.) Multi-touch-resistive technology is created by patterning indium tin oxide (ITO) transparent conductors on PET film and/or glass. The advantages of this modification of analog resistive are that it supports multi-touch and is significantly lower cost than projected capacitive; the disadvantages are all the same ones as analog resistive (e.g., low durability and poor optical performance). It remains to be seen if the cost advantage of multi-touch resistive will remain significant as the volume of projected capacitive rockets upwards.

**Optical Imaging:** Optical-imaging touch-screen technology can be very cost-effective in large sizes (>10 in.) because it requires only two cameras and an infrared (IR) source. Initial suppliers of optical-imaging touch technology included Canada-based SMART Technologies and New-Zealand-based Next-Window. Along with multi-touch resistive, projected capacitive, traditional infrared, and SAW touch technologies, optical imaging is aiming to ride the wave of Windows 7,

Microsoft's first operating system to support multi-touch, launched in September 2009. As optical imaging has taken off, more companies are entering the market. For example, Taiwan-based Quanta has started manufacturing desktop and notebook PCs that include optical-imaging touch. Quanta uses Pixart Imaging as its touch-controller IC supplier; Pixart Imaging licensed SMART Technologies' DViT (Digital Vision Touch) technology and related know-how in 2009.

**In-Cell:** In-cell touch has been a kind of Holy Grail in the touch industry for the last 3 years – it just seems natural for touch to be totally (and invisibly) integrated into the displays. Research continued during 2009 on in-cell in all three technology variations – photo-sensor (also called light sensing), sensor switch (also called voltage sensing), and capacitive spacer (also called charge sensing). One key milestone occurred in May 2009 when the first actual product using any form of in-cell touch started shipping. The product, a netbook from Sharp that sold only in the Japanese market, used a 4-in. 854 × 480-pixel LCD equipped with photo-sensor in-cell touch in place of the conventional opaque touchpad. AU Optronics Corp. (AUO) also announced an in-cell touch-enabled display in 2009. LG Display recently announced it will mass produce 13.3-in. capacitive in-cell by the end of this year. In-cell touch is likely to appear in several mobile phones in 2010. (See the Frontline Technology article, "LCD In-Cell Touch" in this issue.)

**Surface Acoustic Wave:** Surface acoustic wave (SAW) has been one of the workhorses of the touch industry for over 20 years. It has been widely used in kiosks and other public applications. Until 2009, it has always supported only single-touch. Elo TouchSystems changed this when it announced in December 2009 the launch of IntelliTouch Plus, a two-touch implementation of SAW. (See this issue's Industry News for more information.) This was particularly significant not only because of the technical innovation that it represents, but because it allows SAW to compete with optical in the desktop space.

**Multi-Touch:** Multi-touch is defined as the ability to support two or more simultaneous touches. Although multi-touch was invented many years ago, it remained an obscure curiosity until Apple launched the iPhone in 2007. When Microsoft launched Windows 7 in 2009, multi-touch became a "must-have"

characteristic of many consumer touch devices. It is worth pointing out that multi-touch is generally not very significant in most vertical applications. There just are not that many situations where the user of a device such as an ATM or airport check-in terminal needs to touch more than one spot on the screen at a time. Multi-touch is not a touch technology in itself; it is a characteristic that is supported by various touch technologies, including projected capacitive, traditional infrared, optical imaging, bending wave, surface acoustic wave (recently), in-cell touch, and, of course, multi-touch resistive.

It should be noted that just because a given touch technology is capable of supporting multi-touch, not every implementation will expose multi-touch to the user. For example, at the Consumer Electronics Show in January 2010, one vendor was demonstrating a touch-controlled recipe reader intended for kitchen use. When asked if it supported multi-touch, the vendor said that there was no need for multi-touch in the simple, straightforward user interface and that projected capacitive was used in the device because of its high durability and high optical performance.

### Taiwanese Players Entering the Touch Industry

In 2008, there were 37 touch-screen manufacturers in Taiwan, seven of which were pursuing projected capacitive, including J-Touch, Young Fast Optoelectronics, Wintek, and TPK Solutions. Recently, color-filter makers (Cando and Sintek), equipment makers (Usan Technology and Mirle Automation), and driver-IC supplier Sitronix (which partnered with France-based Stantum on multi-touch resistive controllers) have all started to explore the touch market.

### Apple's iPad: A New Wild Card?

In January, Steve Jobs announced that Apple's iPad will be available at the end of March 2010. The iPad will have a 9.67-in. LCD and projected-capacitive touch screen. Apple's iPhone had a big impact on the mobile-phone business and on small-sized projected-capacitive touch screens. How will the iPad impact the mini-notebook/tablet PC and medium-sized touch-screen markets? Will it also stir a new round of "me-too" followers to make similar devices? These questions will be answered during the next year or two. ■

expo  
display

# 2010 Display Taiwan

The 12th Int'l Flat Panel Display Exposition  
Taipei World Trade Center, Hall 1  
www.displaytaiwan.com

June 9-11, 2010

## Exhibits

Display Application Product

Panel / Module

CD Component

CD Material

CD Process Equipment

LED / E-paper / Touch Panel  
Equipment & Material

Software & Consultancy

## Contact :

Mr. Scott Chen

E-mail: [Display@taitra.org.tw](mailto:Display@taitra.org.tw)

Tel: 886-2-2725-5200 Ext. 2631

Fax: 886-2-2725-3510



Organizers



## LASER PATTERNING TOUCH SCREENS, DISPLAYS, and SOLAR

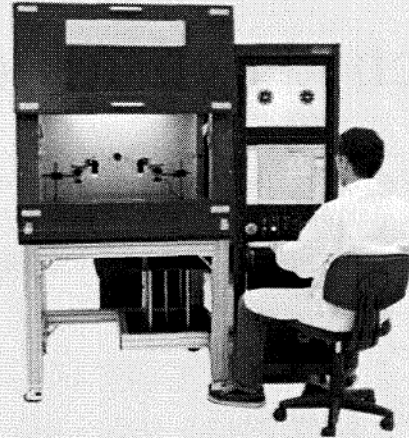

M2-DLP

## YOUR 21st CENTURY SOLUTION!

The meticulous and precise preparation of your ITO coated substrates using our one-step laser ablation procedure, yields pristine results without the risks inherent in conventional methods. One simple step without masking, chemical mess, substrate damage or lateral etching. Just crisp, laser-straight, clean lines.

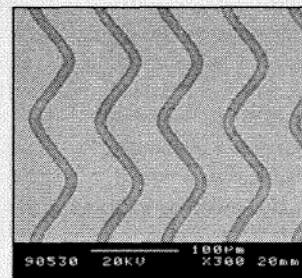

We sell systems AND  
we offer a Laser Job Shop Service

We also support you throughout the R&D cycle.  
Prototypes to Production and even Super Production.

Visit with our experts at Booth 1120,  
SID Seattle, May 25-27



20312 Gramercy PL  
Torrance CA 90501 USA

310-328-5869 888-991-9916

[sales@laserod.com](mailto:sales@laserod.com) [www.laserod.com/ITO.shtm](http://www.laserod.com/ITO.shtm)

# Touch Screens and Touch Surfaces are Enriched by Haptic Force-Feedback

*Tactile feedback can enable more effective use of touch screens, particularly in automotive applications where driver distraction is a problem. The number of technologies used to produce haptic effects continues to increase, providing many options and opportunities for system designers.*

by Bruce Banter

**T**HE TERM HAPTICS comes from the Greek word haptikos (from haptesthai, to grasp or touch). For touch user interfaces, the term typically refers to a tactile sensation or force-feedback that users experience when touching the surface. Conventional touch screens do not provide the tactile sensation of mechanical buttons and knobs, resulting in a less satisfying experience. Haptics technology can reproduce the same feel or tactile sensation as mechanical buttons and knobs or generate new sensations not previously possible. Tactile sensation can be more emotional and personal than sight or sound and can therefore enrich the user experience and perception of the interaction.

Haptics have been utilized in automotive applications for some time in rotary controls with joystick types of motion. Conventional rotary knobs are limited with fixed detents ("bumps") and degrees of rotation (end-stops). BMW's iDrive, launched in 2001, was the first haptic interface that provided different feelings (feedback) for different functions with one control. The device operated with

rotary and four-axis joystick motions to control the functions on the display. The concept has evolved into the COMAND controller in the Mercedes S-Class, the Multi Media Interface (MMI) in most Audi models, and the Remote Touch controller in several Lexus models. Some automotive OEMs believe that these types of rotary/joystick inputs are similar to computer mouse controls and provide more intuitive and comfortable operation than touch screens.

Haptics was presented as a key enabler for touch user interfaces in the article "Tactile-Feedback Solutions for an Enhanced User Experience" in the October 2009 issue of *Information Display*.<sup>1</sup> This article expands on the information in that piece and presents some new information on additional haptic technologies and the use of haptic force-feedback in automotive touch-screen applications.

## Touch Screens and Touch Surfaces

Touch screens and surfaces are increasingly replacing the conventional mechanical buttons and knobs in automotive controls because of their ability to provide a reconfigurable user interface (UI) that blends with the vehicle's theme or styling while improving cost and reliability. Automotive UIs have been changing to meet customer expectations for better interaction. The proliferation of portable devices in vehicles is also driving the need to reduce driver distraction and keep attention on

the road. Touch screens are enabling the customization and adaptability of the UI for improved presentation of information and user inputs. The main disadvantages of touch screens have been fingerprints on the screen and the lack of tactile feedback.

Haptics are being utilized to provide unique information to automotive users. Sliding motion inputs such as radio volume or fan speed can be enhanced by increasing the rate and intensity of feedback as the finger moves across the surface to correspond to the loudness of the radio or speed of the fan. Users are able to learn and identify features coded with unique haptic effects. The muscle memory of haptic effects can easily be recognized and quickly understood even without confirmation of sight and sound feedback.

The type and size of information displays impact the need for touch screens and haptics. Automotive OEMs initially began using smaller LCDs and OLED displays for cluster, radio and climate controls without touch interaction. Over time, the "center-stack" area has evolved into a major control, navigation, and communication hub with display sizes continuing to increase, providing increased room for user interaction. Eight-inch LCDs are becoming common in automobiles today. Adaptive and reconfigurable UIs are required to provide an increasing amount of information to the driver and passengers. Multiple screens are

---

*Bruce Banter is Chief Engineer at Tech-D-P. He has been active in developing HMI controls for more than 20 years and was previously Chief Engineer at Methode Electronics, Lear, and TRW. He can be contacted at 248/763-7838 or bruce.banter@techdp.net.*

being utilized to present different types of information. Touch screens, proximity sensing, and haptics are key parts of providing unique experiences for each screen.

The trend of vehicle-interior styling is toward organic and flowing lines. The center-stack area is being blended into the instrument panel and the center console, creating complex surfaces that leave little room for flat glass panels. Molded surfaces are the trend with decorative finishes. Projected-capacitive touch screens (one of the few touch technologies that can be applied to a curved surface) are being developed for several applications to match the trend. Applying touch, haptics, and motion to a complex surface is challenging, and haptic design considerations must be incorporated during the initial stages of the vehicle-interior design.

### Adding Haptics

Optimal UI experiences employ the senses of sight, sound, and touch. The move from mechanical buttons and knobs to touch screens and surfaces can result in the loss of tactile feedback. Users have been programmed to expect tactile confirmation of inputs with mechanical switches. Studies have shown increased input speed, increased accuracy, and less frustration when haptic feedback is part of the UI.<sup>2</sup> Some current automotive applications of touch screens and surfaces utilize only sight and sound because they are the easiest to implement. Several user clinics and studies have been conducted by automotive OEMs to understand user preferences, and they indicate that users prefer the combination of tactile force-feedback and sound.<sup>3</sup>

The type of haptic effect can vary in complexity from simple vibrations to multifaceted effects driven by complex mathematical models (see Fig. 1). Simple rumble vibrations have been used in mobile phones for several years, but they are evolving to more intricate effects. High-fidelity force-feedback has been shown to produce a more authentic response and engaging user experience. The new gesture-rich user interfaces that are beginning to appear in consumer products will undoubtedly require high-fidelity feedback.

### Producing Haptic Effects

Most haptic effects are produced by stimulating the nerve receptors in the finger by motion of the touch surface or vibration of the skin. Movement is generated by pushing or pulling

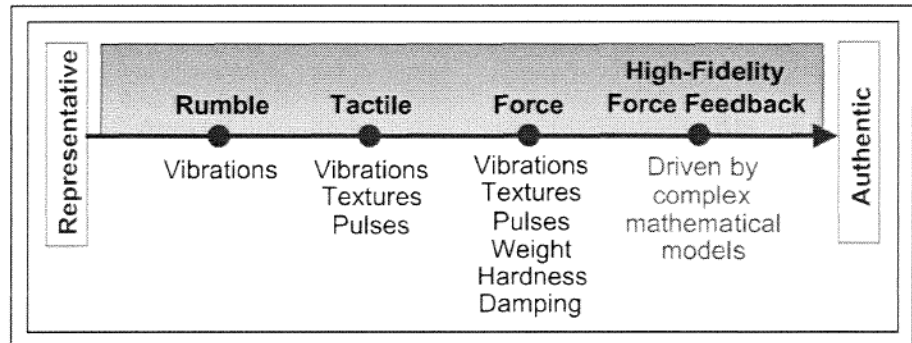

**Fig. 1:** The spectrum of haptic feedback ranges from simple vibrations to complex multifaceted events, with the latter being perceived as a more authentic representation of the original tactile feedback it is designed to replicate. Source: Immersion Corp.

the surface with either a prime mover or magnetic or electrostatic attractive forces. Control of the movement is accomplished by varying the amplitude, frequency and duration of the driving current or voltage. The seven methods currently being utilized to produce haptic effects are shown in Table 1.

The following paragraphs discuss each of these seven methods. (See the aforementioned October article for additional details on inertial, piezo, and surface actuation).

### Inertial Actuation

Eccentric rotating mass (ERM) inertial actuators have been used as vibrators in mobile-phone applications for many years and they are starting to be used to produce haptic touch

screens. Immersion Corp. has long been a leader in this technology, offering its TS2000 software development kit (SDK) and associated design support.

### Piezo Actuation

Piezo actuation is generated by piezo-ceramic elements that deform with applied voltage. The piezo elements are applied to the touch surface, and haptic effects are created by the flexing motion of the elements against another surface. SMK is a leading supplier of resistive touch screens; it has been including piezo force-feedback as an option in its resistive touch screens for a number of years. SMK's first automotive haptic touch screen was introduced with "PulseTouch" in 2004 in Alpine's

**Table 1:** Inertial actuation and Capacitive Electrosensory Interface (CEI) are but two of the seven methods currently being used to produce haptic feedback.

| Haptic Method                             | Description  |
|---|--|
| Inertial Actuation                        | Shaking the surface or the entire device with oscillating rotary or linear-mass actuators                              |
| Piezo Actuation                           | Flexing the surface with piezo disks or strips   |
| Surface Actuation                         | Moving the surface with electrostatic attraction   |
| Lateral Actuation                         | Moving the surface laterally with electromagnetic actuators  |
| Electro-Active Polymer Actuation          | Moving the surface by contraction and expansion  |
| Bending Wave                              | Moving the surface with piezoelectric sensors  |
| Capacitive Electrosensory Interface (CEI) | Generating electrostatic pressure and stimulation in finger nerve-endings through the application of an electric field |

## enabling technology

IVA-D300 aftermarket audio head unit. Development has continued with several automotive OEM applications currently in progress.

SMK's piezo-ceramic actuators are a proprietary material that can be applied in a thickness of 1 mm to resistive film-glass or glass-glass touch screens. Accelerations of 2G can be created with high bandwidth to accomplish high-fidelity effects. SMK has worked with Immersion to provide 25 haptic effects that can be embedded in applications. Their latest generation of products includes a gesture-recognition touch screen with two-finger multi-touch that changes the haptic feedback according to the pressure applied. The change in resistance triggers the change in the haptic effect. Projected-capacitive touch screens that incorporate SMK's piezo actuation are also under development.

### Surface Actuation

Surface actuation, developed by Pacinian Corp., is a technology that shows great promise. The October *Information Display* article explains the operating principle in more detail, but the basic premise is electro-attractive force between two surfaces with a charge differential. System response time is fast from 0 to 500 Hz. The actuation mecha-

nism can be incorporated into the touch-screen components without the need for a separate actuator, which results in a very thin profile. High reliability has been demonstrated with more than 200 million actuations achieved during testing. Pacinian offers hardware and software development support.

### Lateral Actuation

Lateral actuation is accomplished by electro-mechanical actuators that move the touch surface in a lateral direction to produce the haptic effect. The small lateral motion (0.2–0.3 mm) stretches the skin of the finger and the tactile receptors. Immersion has developed this technology and provides implementation support with mechanical, hardware, and software design. It has been very active in characterizing and replicating various tactile feelings into haptic effects. An SDK is available to implement an embedded control design and customize haptic effects.

The motion of the touch surface is controlled by the actuator flex frame or by a separate sliding or flexure mechanism with the actuators providing the only force. Multiple actuators can be used to move more mass. Haptic touch screens of 30 in. have been successfully developed. Accelerations of

several Gs can be produced to generate high-fidelity haptic effects. Immersion's A110 actuators (Fig. 2) have been tested to automotive-grade requirements and have completed 1 million test cycles.<sup>4</sup> This technology has become the benchmark for haptic touch screens, particularly with regard to the fidelity and strength of effects and the maturity of support and capability data.

### Electro-Active Polymer Actuation

Electro-active polymer actuation (EPAM) creates motion by applying a charge to electrodes separated by a dielectric polymer film to create an attraction force that causes the polymer film to contract in thickness and expand in area. The motion is directed in the desired axes by attaching frames and materials. This technology, developed and licensed by Artificial Muscle, is available in several types of actuators; the company's Z-Mode and Reflex HIC actuators are used for touch-screen applications. The Reflex actuator's output is claimed to be directly proportional to the input signal, providing fast response time and the ability to reproduce almost any waveform.

### Bending-Wave Actuation

UK-based NXT has adapted its bending-wave technology that was originally developed for loudspeakers to produce both touch-point location and haptic effects (but not simultaneously) in touch screens.<sup>5</sup> In the former case, NXT licenses its bending-wave technology to 3M Touch Systems for its Dispersive Signal Technology (DST) touch screens; these use piezoelectric sensors at each corner of the screen to convert the mechanical energy from the bending waves produced by a touch into electric signals that are used to calculate the location of the touch point. In the latter case, the same bending-wave technology is licensed to Nissha Printing for use in high-fidelity haptic touch screens. A wide variation of tactile sensations can be produced as a result of the wide bandwidth provided by the system; it can even be extended into the audio range to allow the touch screen to also provide audio feedback. Most haptic effects are produced below 500 Hz; localized feedback is possible with different effects in different locations.

### Capacitive Electro-sensory Interface

Capacitive Electro-sensory Interface (CEI) or E-Sense is yet another type of haptic technol-

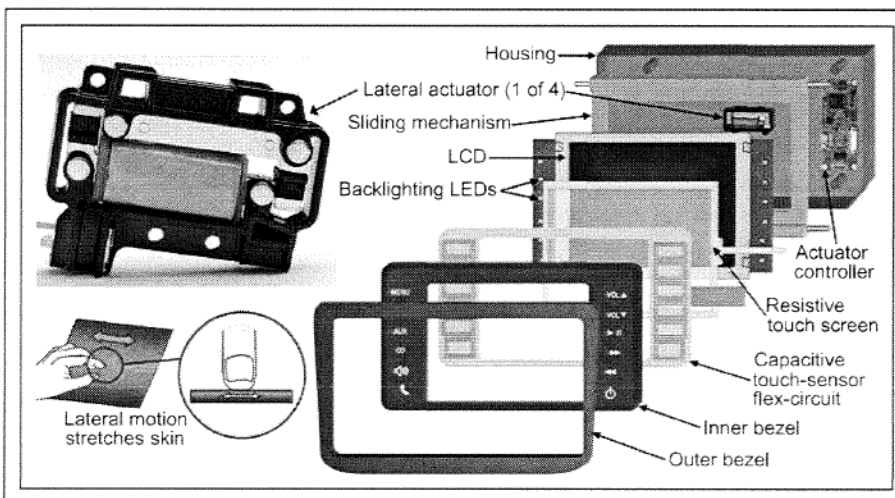

**Fig. 2:** Immersion's A110 Touch Sense Actuators (upper left), manufactured by Johnson Electric, provide lateral movement of touch surfaces. Lateral (side-to-side) movement of the touch surface stretches the skin and stimulates the nerve receptors to produce tactile sensations (lower left). An exploded diagram of a typical automotive LCD assembly (right) illustrates the combination of a lateral haptic feedback mechanism behind the LCD, a resistive touch-screen on top of the LCD, and capacitive-sensing backlit buttons surrounding the LCD. Source: Immersion Corp.

ogy that was developed by Sweden-based Senseg.<sup>6</sup> Instead of moving the touch surface, this technology generates electrostatic pressure in the skin of the finger by establishing a charge differential that creates a Coulomb force between the E-sense layer integrated into the touch surface and the finger tissues. The force is modulated in frequencies where the human vibration perception is most sensitive; the oscillating force causes the skin to vibrate and the nerve endings interpret this as touch sensation. Electric-field strengths are below the insulation breakdown so there is no electric arc between the finger and the touch screen. The finger does not have to actually be touching the surface to generate the force. Different areas of the touch screen or surface can be controlled individually to generate small tactile areas that Senseg calls “tixels.” The sensations are best felt with light touches or swiping gestures. Virtual surface textures can be created on the touch surface in areas being touched. Senseg provides design and component support for integration of the technology.

### Visteon: Contributing to Haptics User Research

Visteon Corp. is a major supplier of automotive UI controls (as shown by the example in Fig. 3) and has been a leader in developing touch controls with haptic feedback. The company has developed several touch-screen products that include haptic feedback to identify and solve challenges in implementing the technology and gain user insight. Dr. Michael Tschirhart has been leading the company’s user research efforts to gain richer insight into the consumer’s perception of haptic technology. In an interview with the author, Dr. Tschirhart said, “This research helps Visteon discover factors that determine the attributes that individuals perceive when using haptics. These findings [many of which are as yet undisclosed] are used to guide the development of haptic solutions that can be tailored to meet the desired objectives of car makers.”

### When Will Haptics Take Off?

Haptics has gained acceptance in mobile phones but has been slow to take off in touch screens for other applications. Many companies are evaluating haptic implementations and weighing the risk and cost of adding the feature. What are the costs and design



*Fig. 3: A haptic touch screen shown by Visteon at the Consumer Electronics Show in January 2010 shows an automotive “infotainment” panel demonstrating the implementation of an 8-in. multifunction touch screen as part of an integrated control panel housed within the organic and flowing lines of a modern center-stack. Source: Visteon.*

challenges to add the additional hardware and software and will consumers see value in the feature? Adding motion to most assemblies requires new or significant re-design. Will some combination of light and sound feedback be sufficient to satisfy consumers? The research seems to indicate that consumers prefer tactile feedback once they are aware of the possibility. How reliable are the technologies? The supporting reliability data is growing, but many of the technologies are very new. Mechanical buttons and knobs have functioned well and are well-understood from a cost point of view, so why replace them? The iPhone triggered the migration to touch screens and away from the fixed UI of

mechanical buttons. OEMs are waiting or proceeding cautiously to see if the costs and risks of implementing haptic technologies can be justified.

Automotive products have much longer development cycles than consumer electronics and industrial controls, but automotive OEMs have awakened to the benefits of integrating the latest consumer-electronics technology into their vehicles. They understand that consumers want to interact with their vehicles the same way they do with their electronic devices. Several OEMs are studying haptic touch screens for user interactions and preference. The first major applications will be in 2012-model vehicles.

## enabling technology

### Conclusions

Time will tell which haptic technologies provide the best value and the most consumer acceptance. Each technology has advantages and challenges but the application will dictate the best fit. Haptics should grow in acceptance as consumers begin to experience the advantages. The main key will be to use haptics not just to replace the feel of mechanical buttons but to create new holistic and engaging user interfaces. Developers will be able to move in creative directions that are not possible with touch screens alone or mechanical buttons. Implementation costs will decline as volume provides economy of scale and new, more cost-effective methods and components are developed. Haptics is truly an enabler of touch screens and the futures of both these technologies are intertwined.

### Acknowledgments

The author would like to thank the following individuals and companies for providing information for this article. Additional infor-

mation on the technologies and companies is available through them.

- Immersion Corp.: Mike Blicher, Director Business Development, mblicher@immersion.com
- Pacinian Corp.: Mike Levin, V.P. Business Development, mlevin@pacinian.com
- SMK: Jeffrey Riggs, JeffreyRiggs@RiggsProductGroup.com
- Visteon Corp.: Dr. Michael Tschirhart, Technical Fellow & Advanced HMI Manager, mtschirh@visteon.com
- NXT: Geoff Boyd, New Business Development Director, g.boyd@nxtsound.com
- Senseg, Ltd.: Ville Makinen, CEO, ville.makinen@senseg.com

### References

<sup>1</sup>M. Levin and A. Woo, "Tactile-Feedback Solutions for an Enhanced User Experience," *Information Display* 18-21 (October 2009).

<sup>2</sup>M. Silfverberg, "Using Mobile Keypads with Limited Visual Feedback: Implications to Handheld and Wearable Devices," *Mobile HCI 2003*, ed. L. Chittaro, LNCS 2795: 76-90 (2003).

<sup>3</sup>J. L. Burke, M. S. Prewett, and L. R. Elliot, "Comparing the Effects of Visual-Audio and Tactile Feedback on User Performance: A Meta-Analysis," *Proceedings of the 8th International Conference on Multimodal Interfaces*, 108-117 (2006).

<sup>4</sup>Immersion Corp., 2009

<sup>5</sup>N. Harris, "Applications of Bending Wave Technology in Human Interface Devices," presented at the 126th Convention of the Audio Engineering Society (2009).

<sup>6</sup>J. Linjam and V. Makinen, "E-Sense Screen: Novel Haptic Display with Capacitive Electrosensory Interface," presented at HAID 09, 4th Workshop for Haptic and Audio Interaction Design, Dresden Germany (Sept. 10-11, 2009). ■

## NEW! System Solutions for Driving Mid-Sized LED Backlit Display Panels

LXMG1960-28™

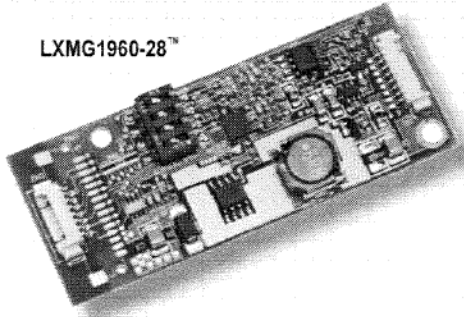

- Boost converter with up to 6 programmable current sinks
- Programs string current between 10mA and 25mA in 1mA steps
- 1% string-to-string current matching
- StayLIT™ feature assures operation in case of open strings or shorted LEDs
- Wide 4.75V-28V input voltage capability
- Multiple dimming options with up to 1,000:1 dimming capability
- Short-circuit/over-voltage protection; optional LED over-temperature protection

### Flexible, Easy to Integrate Modules Provide High Performance for Multi-String Panels

Microsemi's new LXMG1960-28™ LED driver modules supply superb performance and advanced features that you simply plug in. Based on our feature-rich LX1996™ controller, these new modules are ideal system solutions for mid-sized displays in medical, point-of-sale, kiosk, ATM and lottery terminals. Their flexible configurations are enhanced by built-in and optional safety options.

Microsemi provides a wide range of high performance backlight driving solutions for LED and CCFL televisions, notebook computers, automotive and other displays that can be enhanced by our proprietary light sensor and color management solutions.

For full details, including panel matching tables, visit our website at <http://www.microsemi.com/products/backlight/overview.asp>



See Us at Display Week 2010 in Seattle



Journal of the

**SOCIETY FOR  
INFORMATION  
DISPLAY**

The following papers appear in the April 2010 (Vol. 18/4) issue of *JSID*.  
For a preview of the papers go to [sid.org/jsid.html](http://sid.org/jsid.html).

**A practical approach to processing flexible displays** (pages 258–265)

*Jun H. Souk and Woojae Lee, Samsung Electronics Co., Ltd., Korea*

**A single-cell-gap transfective LCD using active-level-shift technology** (pages 266–270)

*Seon Hong Ahn, Yong Seok Cho, Yong Kyu Jang, and Chi Woo Kim, Samsung Mobile Display, Korea*

**Driver-circuits-integrated LCDs based on novel amorphous In-Ga-Zn-oxide TFT** (pages 271–276)

*Takeshi Osada, Kengo Akimoto, Takehisa Sato, Masataka Ikeda, Masashi Tsubuku, Junichiro Sakata, Jun Koyama, Tadashi Serikawa, and Shunpei Yamazaki, Semiconductor Energy Laboratory Co., Ltd., Japan*

**Charge carriers and charge-transfer reactions in OLED devices studied by electron paramagnetic resonance** (pages 277–284)

*Thomas D. Pawlik, Denis Y. Kondakov, William J. Begley, and Ralph H. Young, Eastman Kodak Co., USA*

**Optical characterization and ergonomical factors of near-to-eye displays** (pages 285–292)

*Toni Järvenpää and Monika Pölönen, Nokia Research Center, Finland*

**A common approach to characterizing autostereoscopic and polarization-based 3-D displays** (pages 293–300)

*P. Boher, T. Leroux, V. Collomb-Patton, T. Bignon, and D. Glinel, ELDIM, France*

**Quantum chemistry and QSPR study on relationship between crystal structure and emission wavelength of Eu<sup>2+</sup>-doped phosphors** (pages 301–309)

*Hiroaki Onuma, Itaru Yamashita, Kazumi Serizawa, Hideyuki Tsuboi, Nozomu Hatakeyama, Akira Endou, Hiromitsu Takaba, and Momoji Kubo, Tohoku University, Japan; Hiroaki Tanno and Hiroshi Kajiyama, Hiroshima University, Japan; Ai Suzuki and Akira Miyamoto, New Industry Creation Hatchery Center, Tohoku University, Japan*

**Depth image-based rendering for multiview generation** (pages 310–316)

*Young Ju Jeong, Yong Ju Jung, and Du-sik Park, Samsung Electronics Co., Ltd., Korea*

**Transmissive electrowetting-based displays for portable multimedia devices** (pages 317–325)

*Andrea Giraldo, Jo Aubert, Nicolas Bergeron, Eric Derckx, Johan Feenstra, Romaric Massard, Jurrien Mans, Anthony Slack, and Paul Vermeulen, Liquavista BV, The Netherlands*

**SID**  
SOCIETY FOR INFORMATION DISPLAY

## Beneath the Surface

*Surface computing is about integrating the physical world and the virtual world through the use of vision-based touch. While Microsoft's Surface product is the best-known implementation of surface computing, it is far from the only one. Expanding university research on touch continues to make use of vision-based touch as a foundation, which in turn will help move surface computing toward full commercialization.*

by Geoff Walker and Mark Fihn

**T**HE TERM "surface computing" (sometimes called "tabletop computing") describes a specialized computer graphical user interface (GUI) in which (1) the keyboard and mouse are completely replaced by a touch-sensitive display and (2) users interact with common and intuitive objects rather than conventional GUI elements such as windows, icons, and drop-down menus. The goal of surface computing is to integrate the physical world and the virtual (digital) world more closely so that digital information becomes immediately and easily available when users interact with a physical object or an environment.

### Conceptual Examples

One example of surface computing is a horizontal touch display that has been used on a trial basis in retail mobile-phone stores. The user/prospect places two physical phones on the display's surface. The software driving the display identifies the phones and immedi-

ately displays a comparison of the two phones' features, specifications, and pricing. The user can then interact with the information using his hands to explore details or modify the way the phones are compared. Another example involves placing a digital camera on the display surface and having the photos in the camera automatically copied to the display, where the user can interact with them using multi-touch finger-gestures such as flicks, pinches, rotations, *etc.* The photos can be transferred to a mobile phone simply by placing the phone on the display surface and dragging the photos over to it.

### History

Around the mid-1990s, a variety of companies and institutions began conducting research on surface computing, including Alias/Wavefront, Microsoft, MIT Media Lab, Mitsubishi Electric Research Labs (MERL), New York University, Sony Computer Science Labs, the University of Toronto, and Xerox PARC.<sup>1,2</sup> MERL's announcement of the DiamondTouch interactive table in 2001 heralded one of the first commercially available surface-computing products, but it was viewed as a research curiosity and was not fully commercialized. Microsoft's hype-filled announcement of the Surface product in May 2007 caught the public's attention in a big way. The widespread publicity that Microsoft's announcement received caused the Surface product to become synonymous with surface

computing. However, innovations related to surface computing are not unique to Microsoft, and there are numerous other efforts enabling the technology.

### Technology

As with all touch-screen technologies, there are two interrelated components – the display device and the touch-sensing device. On the display side, surface computing can work with any type of display, including flat panel, rear projection, and front projection. On the touch side, the choices are more limited. While some early implementations such as DiamondTable used capacitive sensing, essentially all current implementations of surface computing use infrared (IR) vision-based sensing; this requires one or more IR imaging cameras to be positioned so that an image of the entire screen can be captured. This means that today all surface computers use either rear or front projection, which eliminates true "tabletop" use – unless the surface computer is itself a table, like Microsoft Surface (illustrated in Fig. 1).

### IR Light Source

There are currently three methods of supplying the IR light that is received by the vision-based camera in surface computing. These methods, Diffused Illumination (DI), Frustrated Total Internal Reflection (FTIR), and Diffused Surface Illumination (DSI), are explained in the following paragraphs.

---

*Geoff Walker is the Marketing Evangelist & Industry Guru at NextWindow, the leading supplier of optical touch screens. He can be reached at 408/506-7556 or gwalker@nextwindow.com. Mark Fihn is publisher of the Veritas et Visus newsletters, focused on the technologies and markets related to flexible displays, display-related standards and regulations, 3-D displays, high-performance displays, and touch screens. He can be reached at 254/791-0603 or mark@veritasetvisus.com.*

- **DI:** Diffused Illumination can be used with either front- or rear-illumination systems. Rear DI (used in Microsoft Surface) utilizes infrared light projected on the screen from below the touch surface. A diffuser is placed on the top or the bottom of the touch surface. When an object touches the surface, it reflects more light than the diffuser (or objects in the background), and the extra light is sensed by a camera. Depending on the diffuser, this method can also detect hover above the screen and can identify objects placed on the surface. In the case of front DI, infrared light is projected on the screen from above the touch surface, such that a shadow is created when an object touches the diffused surface and can then be similarly recognized by a camera.
- **FTIR:** Popularized in the touch-screen world by Jeff Han when he was at NYU (he's currently the Founder and CEO at Perceptive Pixel), the concept of Frustrated Total Internal Reflection is a physical condition related to differences in the refractive indexes of adjacent materials. When light passes from one material to another with a higher refractive index at an angle of incidence greater than the specific angle (described by Snell's Law), then no refraction occurs in the material, and light is reflected. This method traps infrared light in an acrylic overlay, which is frustrated (scattered) at the point of a touch; the scattered light is then recognized by camera-based imaging. Figure 2 illustrates the concept.
- **DSI:** Diffused Surface Illumination uses a special acrylic to distribute the IR evenly across the surface. This method relies on small particles inside the acrylic, which function like tiny mirrors. When IR light is injected into the edges of the acrylic (as in FTIR), the particles redirect the light to the surface and spread it evenly. When a user touches the surface, the light is scattered and seen by the vision-based camera as a blob of IR light.

### Significance

Vision-based touch systems have not yet achieved any substantial commercial penetration. The technology is in a state somewhat similar to that of projected capacitive ("pro-cap") in the early-to-mid 2000s – it's a niche

technology waiting for a breakthrough. In the case of pro-cap, the breakthrough was Apple's decision to use it in the iPhone; that decision had an immense effect not only on the technology, but also on the entire touch industry.

The authors believe that vision-based touch has even more potential to change the world than pro-cap. The latter is, after all, simply a substitute for a mouse and keyboard in interacting with the standard GUIs running on the iPhone OS and Windows. Interaction with computers has not been changed in any fundamental way by pro-cap touch screens: it's just been made simpler and more fun, especially on small mobile devices. In contrast, surface computing at its core is an attempt to totally change the way people interact with computers. Putting a digital camera down on an interactive surface, having the photos it contains spill out onto the surface, interacting with the digital photos on screen through multi-touch gestures, and sharing the photos with several other people in a tabletop envi-

ronment is very different than tapping icons and selecting menu items on an iPhone.

There is one other characteristic of vision-based touch systems that's significant, and that is the fact that they can be assembled from inexpensive standard parts and open-source software.<sup>4</sup> No other multi-touch-capable touch technology can be obtained in this way. As a result, the majority of touch research being conducted in university research labs uses vision-based touch as its foundation. This means that there is an expanding body of work being developed on vision-based touch along with steadily increasing knowledge and understanding of the technology; this increases the probability of a breakthrough that will drive the technology toward full commercialization.

Hardware and software developers remain excited about viable commercial uses of surface computing and continue to innovate. A few data points on progress in this area include the following:

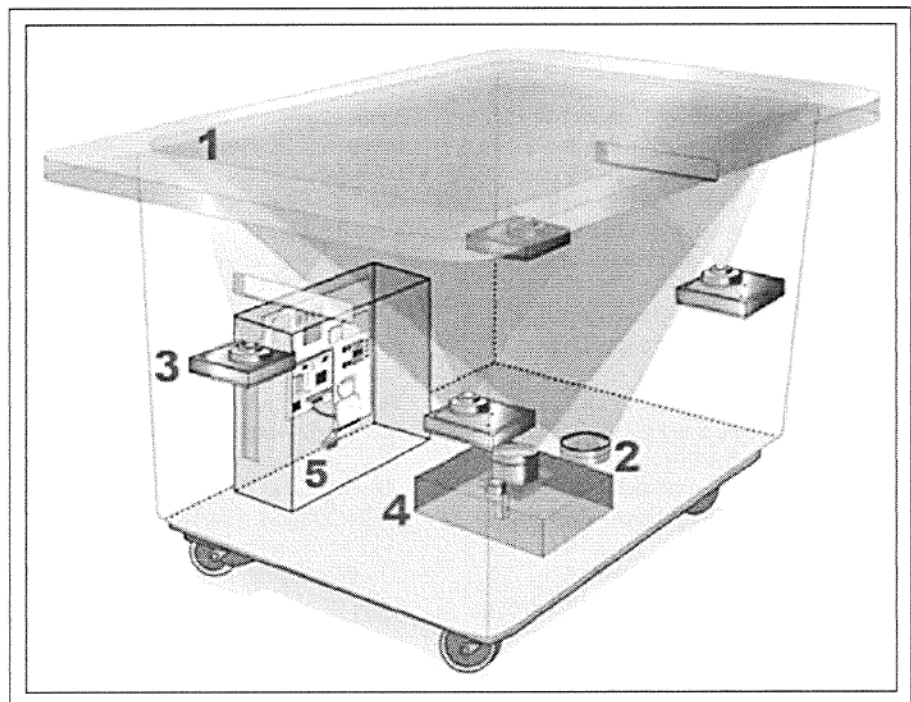

**Fig. 1:** Schematic format of Microsoft's Surface computer product. The components numbered in blue are as follows: (1) acrylic tabletop touch surface with a diffuser; (2) 850-nm infrared light source directed at the underside of the touch surface; (3) infrared camera (one of four with a combined total resolution of 1280 × 960 pixels); (4) Texas Instruments' DLP projector running at 1024 × 768 pixels; (5) desktop computer running a customized version of Microsoft Vista. Source: Microsoft.

## enabling technology

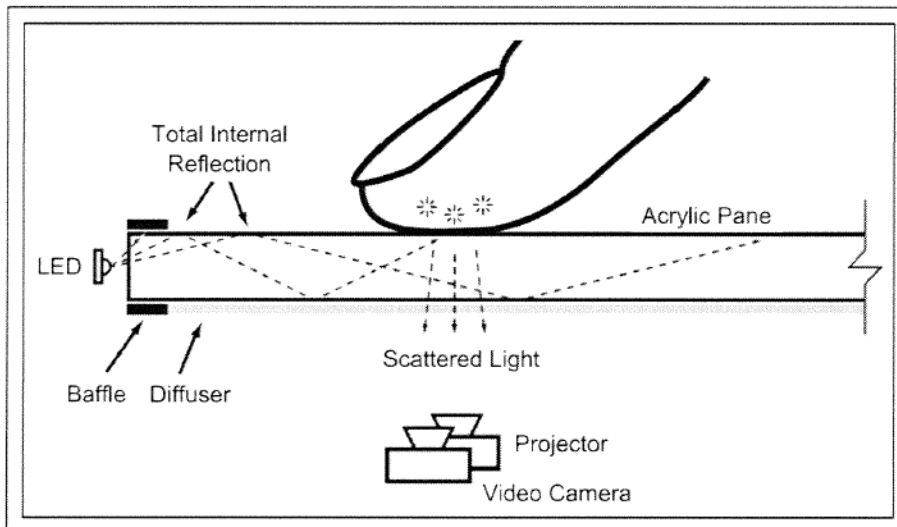

**Fig. 2:** This figure illustrates how FTIR can be used to sense touch. A rear-projection screen (diffuser) is attached with a small air gap to the underside of a sheet of acrylic. Infrared LEDs inject light into the polished edge of the acrylic; TIR causes the light to remain trapped within the sheet. A baffle blocks light with a higher angle of incidence near the edge of the acrylic. When a finger touches the surface of the acrylic, it "frustrates" TIR and causes light to scatter out through the acrylic towards a vision-based camera equipped with an IR bandpass filter. Source: Media Research Laboratory, New York University.<sup>3</sup>

- MERL's DiamondTouch interactive table, mentioned earlier in this article, has been licensed exclusively by startup Circle Twelve, Inc., which is marketing it as a collaboration tool. The Diamond-Touch table enables multiple simultaneous inputs such that each user can be separately identified. The technology uses front projection and capacitive sensing.
- SMART Technologies offers a vision-based direct-touch technology, which is commercially available and widely used in education and collaboration applications. SMART offers touch tables and rear-projection interactive whiteboards that incorporate the technology.
- GestureTek markets a multi-touch table in sizes from 30 to 55 in.; installed applications include wayfinding and entertainment. GestureTek holds the world's record for the largest surface-computing table at 6 m long (located at the Eureka Tower in Melbourne, Australia).
- Microsoft has expanded the concept of surface computing to go beyond just tabletop applications, demonstrating ideas related to spherical surfaces (both

on the exterior, as with a globe) and on the interior (as with a dome).

- Microsoft has demonstrated surface computing using photo-sensors located behind thin-form-factor LCDs (ThinSight<sup>5</sup>). By using an electronically switchable diffuser, Microsoft has also demonstrated that images can be recognized and displayed well beyond the surface of the screen (SecondLight<sup>6</sup>). The recognition of physical objects, either as an interface device that can identify objects, or as a projection device that inserts data on surfaces beyond the surface of the screen, is a computationally formidable user-interface task.
- Several recent projects have investigated the possibility of linking together geographically separated surface computers in order to create a shared workspace for remote collaboration, as if participants are co-located around the same tabletop.

### Conclusion

In the almost 3 years since Microsoft announced Surface, there has been an accelerating flow of ideas and information about surface computing – just try Googling "touch table"! The

technology holds the promise of changing the way people interact with computers, going well beyond (for example) applying touch in the replacement of conventional user interfaces in appliances. There is an expanding body of work on multi-touch, object recognition, direct manipulation, 2-D and 3-D gestures, and related fields that continue to enable innovation in the area of surface computing. The technology is ripe for a breakthrough.

### References

- <sup>1</sup><http://www.billbuxton.com/multitouch/Overview.html>
- <sup>2</sup><http://spectrum.ieee.org/computing/hardware/slideshow-tabletop-computers/0>
- <sup>3</sup>J. Y. Han, "Low-cost multi-touch sensing through frustrated total internal reflection," Symposium of User Interface Software and Technology (2005).
- <sup>4</sup>[http://www.maximumpc.com/article/features/maximum\\_pc\\_builds\\_a\\_multitouch\\_surface\\_computer](http://www.maximumpc.com/article/features/maximum_pc_builds_a_multitouch_surface_computer)
- <sup>5</sup>S. Izadi, *et al.*, "ThinSight: integrated optical multi-touch sensing through thin form-factor displays," ACM International Conference Proceeding Series (2007).
- <sup>6</sup>S. Izadi, *et al.*, "Going beyond the display: a surface technology with an electronically switchable diffuser," Symposium on User Interface Software and Technology, ACM (2008). ■

**Visit  
Information  
Display On-Line  
For daily display  
industry news**

[www.informationdisplay.org](http://www.informationdisplay.org)

**DISPLAY  
WEEKSID**  
Seattle, WA • May 23-26, 2010 • [www.sid2010.org](http://www.sid2010.org)

## editorial

continued from page 2

As you will read in this issue, the field is awash in both somewhat whimsical work such as Surface Computing, as examined in the Enabling Technology article. "Beneath the Surface" by Geoff Walker and Mark Fihn, as well as in more practical challenges, including the actual emulation of a physical control mechanism, which author Bruce Banter describes in the Enabling Technology piece, "Touch Screens and Touch Surfaces Are Enriched by Haptic Force-Feedback."

One of the more fundamental ambitions of touch inventors is the complete integration of touch and displays. By complete I mean the display and touch mechanism being all one physical component, the essential elements being indistinguishable from each other to the user or system designer. In what seems like the distant past, when others and myself worked on doing this with CRTs, we experimented with using layers of the anti-reflective coating on the face of the CRT to also serve as a capacitive touch sensor. It worked, but then LCDs took over the world (more or less), and we moved on to other more commercially viable endeavors. The touch people never forgot this concept, however, and numerous groups continued to experiment with schemes to integrate touch mechanically, optically, and electrically into LCDs. You may have seen these demos at SID over the last 10 years, some working better than others. Within the past year, this work has finally resulted in commercial success. Now a possible new paradigm of product designs is about to emerge in which the bezels can be even thinner and the touch screen is the display. The current and future state of this work is ably described by Geoff Walker and Mark Fihn in their Frontline Technology article "LCD In-Cell Touch." Do not miss this article – in-cell is coming for real.

If you are not already familiar with the richness that well-engineered touch interfaces can bring to a product, take a look at author Mark Hamblin's article titled "Taking Touch to New Frontiers: Why It Makes Sense and How to Make It Happen." Here, Mark explains the ins and outs of user interfaces enabled by touch. Among his past experiences, Hamblin was part of the core multi-touch engineering team at Apple, where he led the design and process development of the touch screen in the original iPhone and subsequent touch products.

I cannot begin to address all the other nuggets of innovation going on in the touch

world or even the rest of the nuggets in this issue, but in case you think I'm getting too effusive over this topic, I invite you to read our Display Marketplace article on "The State of the Touch-Screen Market in 2010" by Display Search's Jennifer Colegrove. She now measures the total market in the mid-billions of dollars, with a growth rate that other display market segments are very envious of. In units, the numbers are staggering, while the number of different suppliers continues to be very large (over 100). There has been only limited consolidation during the last few years, with more evidence than ever that no one technology or supplier can supply solutions for all the applications out there. Touch is one of those elusive technologies where so far the one penultimate embodiment has not yet emerged and may never. With so many unique and diverse approaches, the solution space is almost as broad as the supply base of commercial offerings. For me, this is actually refreshing and I enjoy seeing so many entrepreneurial efforts succeeding alongside each other.

I am extremely grateful for the limitless hard work and enthusiasm our guest editor Geoff Walker brought to this issue. As one of the leading innovators himself, Geoff truly shows his passion for the industry wherever he goes. I hope you enjoy this issue. We continue to welcome your comments and feedback on all that we do at *ID*.

### Correction to Poly-Si Article

We're always pleased when we get reader feedback, and when an error is spotted, we're eager to set the record straight. In this case, we were alerted to some inaccuracies in our Enabling Technology Article titled "An LTPS Overview" published in the December issue. In particular, we were reminded that:

- (1) Low-temperature polysilicon (LTPS) has an higher electronic mobility than amorphous Silicon (a-Si), but an higher hole mobility as well.
- (2) Amorphous-silicon (a-Si) does not contain any crystalline structures. Rather, it has a randomized structure of the silicon lattice. Poly-Si consists of a polycrystalline phase – many small crystallites, but with randomized orientation.
- (3) While LCD manufacturers are not generally integrating drivers with a-Si today, Sarnoff labs did develop a process for a-Si driver integration in the past – it is possible to achieve this.

You can read a corrected version of this article on-line at [www.informationdisplay.org](http://www.informationdisplay.org).

For a more complete explanation of the various types of semiconductor materials being used for active-matrix switches in LCDs and OLEDs, we invite you to review "Flexible Transistor Arrays," by Peter Smith, David Allee, Curt Moyer, and Douglas Loy, in the June 2005 issue of *Information Display*. ■

## 2010 SID International Symposium, Seminar, and Exhibition

### Display Week 2010

### Seattle, Washington

### May 23-28, 2010



#### Submit Your News Releases

Please send all press releases and new product announcements to:

Jenny Donelan  
Information Display Magazine  
411 Lafayette Street, Suite 201  
New York, NY 10003  
Fax: 212.460.5460  
e-mail: [jdonelan@pcm411.com](mailto:jdonelan@pcm411.com)

# Taking Touch to New Frontiers: Why It Makes Sense and How to Make It Happen

*Touch interfaces are appearing in everything from consumer devices to industrial equipment, not because touch is “in fashion,” but because it provides a truly better form of human-device interaction. This article examines the advantages of gesture-based touch interfaces and the key steps to building a device with a great touch experience.*

by Mark Hamblin

**T**OUCH INTERFACES are far more than “fashionable” features used as a selling point for consumers. They are truly a more intuitive form of human-device interface, compared to many alternatives. While the keyboard and mouse still have their place with the PC, touch interfaces can spread more pervasively into entirely new applications by replacing simple, “low-tech” interfaces such as buttons, dials, and even paper.

Examples include the electromechanical interface found on a washing-machine dial, the button/menu based interface on some medical equipment, and even the non-interactive paper-based interface of a restaurant menu, all of which may someday be replaced by a well-designed, well-implemented touch interface. There are five reasons why this could happen, as follows:

- Touch can simplify interaction with a device.
- Gesture-based touch interfaces are more intuitive.
- Touch provides for more accessible interfaces.
- Touch helps “futureproof” a device.

*Mark Hamblin is the Founder of Touch Revolution, Inc., a touch systems manufacturer based in San Francisco that he founded in 2008. He can be contacted at 415/335-9123 or mark@touchrev.com.*

- Touch enables convergence of other functions into a device.

## Simplified Interface

A well-implemented touch interface can be much simpler to use than a conventional mechanical or button-based interface because it can show the user only those controls that

are relevant to a particular operation, while all the controls in a conventional interface are always present. This characteristic also makes it easy to expand the interface’s functionality because additional functions can remain hidden until they are needed. A touch interface can also be implemented as a sequential guide to help a user easily get

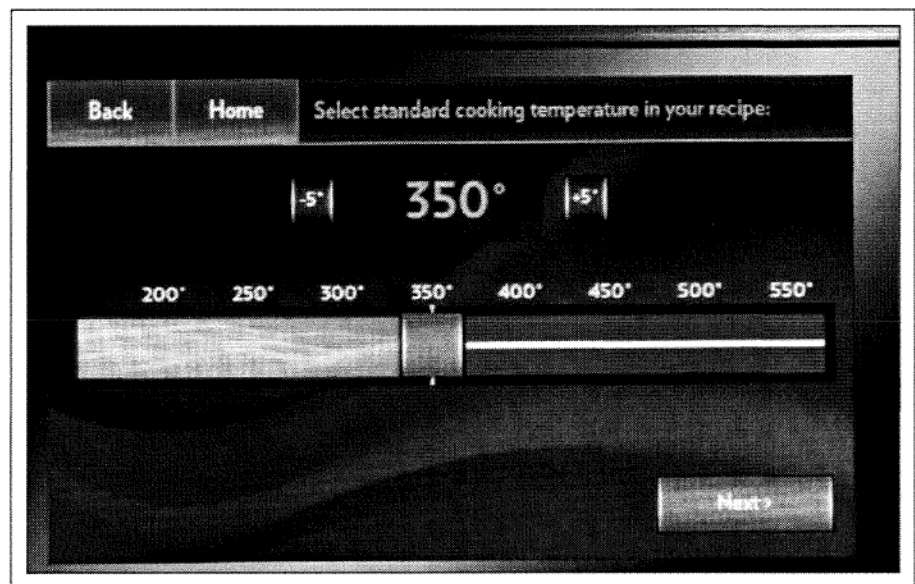

*Fig. 1: One portion of the touch interface on a 2009 wall-oven from Jenn-Air includes a streamlined representation of temperature settings. Source: Jenn-Air.*

through a series of control steps, similar to a “setup wizard” on a PC. Such features improve the user experience by making the device easier to understand. As device makers continue to build more functionality into their devices, the need for simple, interactive touch interfaces will continue to grow.

One example of how touch can provide a simpler interface can be seen on a wall-oven produced by Jenn-Air in 2009, which features a 7-in. projected-capacitive touch display (Fig. 1). Although the Jenn-Air oven interface appears much simpler than the typical non-touch interfaces found on other ovens, it includes additional functionality such as a step-by-step guide for adjusting cook settings based on the food category, type, and desired degree of doneness. Buttons or controls that are not relevant to the immediate process are eliminated, which streamlines the interface, reduces visual clutter, and prevents user confusion.

### Gesture-Based Touch Interfaces

Touch-interface gestures, defined as two-dimensional finger motions, can further simplify an interface and provide an intuitive user experience that goes beyond the typical “button replacement” found in most simple touch interfaces. Gestures allow a sense of control over interface elements that mirror physical elements, allowing for a concept known as “direct manipulation.” For example, swiping emulates the finger motion involved in turning the page of a book, while dragging an interface object around a screen mirrors moving physical objects. Gestures and direct manipulation allow users to employ intuitive actions they already use in the physical world rather than having to learn new actions.

### More Accessible Interfaces

Interactive touch interfaces provide a significant benefit over conventional static interfaces because they can be configured individually for each user. Text and image sizes can be enlarged for elderly users, languages can be changed as required, options can be simplified for beginning users, and pop-up help menus can appear automatically. The device can even automatically make these reconfigurations upon sensing information about the user. Accessibility will become increasingly important as touch interfaces move into more devices in our lives and face an increasingly diverse user base.

### “Futureproofing” Devices

A reconfigurable touch interface without hardware dependencies can provide the ability to modify and improve the interface over time, and even upgrade and change the functionality of the entire device. New features can be rolled out to devices after the initial sale, bugs can be fixed remotely by updating the software over a network connection, interface reconfigurations can be made after actual field usage data is collected, and new applications can be loaded on a device through an online store or other provisioning system. As device manufacturers continue to add more complex features and interfaces to their products, this ability to futureproof the device will become increasingly important. This advantage has already been realized in automotive and GPS applications, for example.

### Convergence of Other Functions

A touch interface is really just a blank slate on which the control of any application or function can exist. This allows a touch interface to be the common element through which various functions can converge into one device. In the past, the need for different physical interfaces such as buttons determined the need for products and applications to be separate. For example, in a business environment, a physical business-card file or phone list (paper interfaces) is often located beside a desktop phone (button interface). Neither of these two products provides an interface that is convenient for the other. But if a gesture-

based touch interface were implemented on the desktop phone, integrating a graphical-user-interface (GUI) based electronic contact directory into the phone’s calling functions would probably improve the utility of the phone and the contact list, as well as being an obvious workflow improvement. In ways such as this, touch interfaces can facilitate product convergence between high-tech and low-tech products.

### How to Create an Interface with a Great Touch Experience

Device OEMs seeking the benefits of adding touch interfaces to their products are often faced with the question of how to do it. They typically look at some of the leading touch products on the market, such as the Apple iPhone, as the benchmark for the “touch experience” – which can be defined as the collection of factors that affect the ease-of-use, intuitiveness, and overall user experience of the touch interface. OEMs looking to create an iPhone-like interface on their product often quickly realize that creating an intuitive, easy-to-use touch interface is not as simple as buying a capacitive touch sensor and “slapping it on top” of an existing product. It is a complex endeavor involving hardware, software, integration, optimization, and testing.

The following paragraphs provide 10 best practices for delivering a great touch experience with a wide range of products from medical devices to mobile phones to home

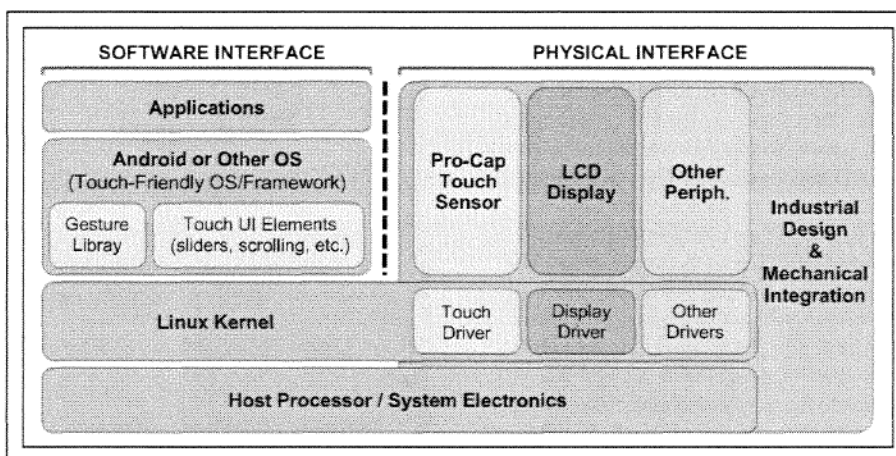

Fig. 2: A block diagram of a touch interface shows the components that must be considered when creating a great touch experience. Source: Touch Revolution.

## making displays work for you

appliances. The touch-interface block diagram shown in Fig. 2 shows most of the components that are discussed in the following paragraphs.

**1. Holistic Design Mindset:** Start with the goal of creating a great touch device, not just adding touch to an existing design. The design must be approached holistically. Factors that must be considered from the beginning of a project include user demographics, the product's industrial design, system hardware selection, supported features, and even the product's price-point.

**2. Touch-Sensor Technology:** Different touch technologies have different advantages and disadvantages, and there are many to choose from – projective capacitive, surface capacitive, analog and digital resistive, surface acoustic wave, optical, *etc.* It is important to note that no one-touch technology solves all problems.

**3. Touch-Friendly Operating System:** Developing intuitive, attractive, gesture-based touch GUIs and applications can be difficult, especially for OEMs who are new to working with touch interfaces. Giving the users the touch experience they now expect can be made easier through the use of an operating-system (OS) software platform specifically built for touch. These platforms, such as the Google Android, Apple's iPhone OS, and Windows 7 (to some extent), make the software developers' job easier by pre-integrating many common touch user interface (UI) elements such as sliders, selection switches, and gestures such as "flick to scroll," "swipe," and "pinch to zoom."

**4. Integration Testing:** It is exceptionally important to plan for sufficient integration testing when developing a touch device, especially when using a capacitive touch sensor. Issues such as RF-EMI affecting the touch sensor, software driver optimizations on the LCD and touch controller, cable-routing, application performance affecting touch responsiveness, unwanted optical interaction between the LCD and the touch sensor, ESD concerns, *etc.*, are quite common. The only way to find and fix these issues is to allow significant time for quality-assurance testing and to have engineers with the right background do the troubleshooting. The amount of effort required to integrate all the hardware and software pieces into a cohesive, responsive, and field-ready product is often underestimated, resulting in delayed, over-budget, or even cancelled products.

### 5. Graphics and Processing Horsepower:

A powerful touch interface can consume a lot of processor cycles. It is important to consider where this processing takes place – in the touch-screen controller's CPU, the host's CPU, or the host's graphics processing unit (GPU). An advanced GUI is pointless unless the hardware has enough horsepower in the right places to run it well, without lags, delays, or choppiness. Cutting back on hardware performance to save cost can severely limit the potential of your GUI.

**6. Display Selection:** Choosing the right display to use in a touch device is especially difficult because of the numerous dependencies between the display and the touch sensor. Important factors to consider include understanding RF-EMI interference issues between the display and the touch sensor, matching the active area and viewing angles, minimizing optical losses, and bonding/sealing the display and touch sensors properly, among many others.

**7. Mechanical Integration:** Most touch sensors (projective capacitive included) are made of glass, which has many benefits but also adds significant constraints when being integrated into a product. The touch sensor must be integrated correctly to prevent breakage in the event of mechanical stresses, to prevent slight deflections of the sensor that could interfere with the sensing baseline, to prevent dust or other contamination from interfering

with viewing quality, and to prevent ESD from damaging the touch sensor or system, among others. Environmentally sealing the touch screen (if required by the device application) can be more difficult than sealing just a display, depending on the touch technology.

**8. Industrial Design:** By their very nature, touch devices are intended to be highly interactive with the user. This means that ergonomics, usability, and intuitiveness are critical. This is important not only for the GUI design, but for the physical design as well. If the device is portable, how does the user hold it? Is there room for a firm grip without touching the screen? If not, does the touch screen use multi-touch to provide "grip suppression"? Is it designed for users of all ages, sizes, and disabilities?

**9. Optimized Touch Software:** With an advanced touch interface, there are many software layers involved in translating the motion of your finger on the touch screen into a responsive action on the LCD and in the application software. The firmware running on the touch controller, the touch and display drivers running in the OS, and the application software itself must all be tested and optimized for responsiveness. Any lags in this software stack will result in a sub-optimal user experience.

**10. Great GUI:** That a touch interface should include a great GUI seems fairly



Fig. 3: This touch-screen interface for a washer-dryer was shown as a demonstration product at the 2010 Consumer Electronics Show in Las Vegas. Source: Touch Revolution.



obvious, but many OEMs still do not seem to get it. A touch interface should be much more than just a series of "virtual buttons" to provide an intuitive, accessible, inviting, fun, and satisfying user experience.

#### Resources

The above "Top 10 Keys to Great Touch Design" is an excellent start, but certainly not complete. Delivering a great touch product to market can be a daunting task, especially for OEMs new to the world of touch. There are many helpful resources OEMs can use to make their touch application a success. A number of touch-controller IC companies offer solutions pre-integrated with a touch screen and OS drivers, minimizing sourcing and technical integration challenges. Some LCD and touch-screen makers are beginning to offer integrated display-and-touch-screen modules. In deciding on a development strategy, OEMs must carefully consider the trade-

offs between cost, schedule, reliability, and overall project risk. While bringing touch interfaces to new applications can be difficult, a well-executed touch product can provide a big payback by attracting new customers, enabling new product features, and even opening new sources of revenue.

#### Future Touch Applications: The Focal Point of Innovation

The future of touch is bright – there will be new technologies, new companies, and new markets. But perhaps even more exciting than the evolution of the touch industry is the impact that touch will have on other industries and applications. Touch interfaces have already helped revolutionize the mobile-phone industry, greatly affecting consumer usage models, network bandwidth requirements, and even enabling major shifts in brand market-share and revenue streams. Touch is likely to do the same for other markets as well.

Take, for example, the home appliance market, and the touch-screen washer-dryer pictured below in Fig. 3, shown as a demonstration product at the 2010 Consumer Electronics Show. Not only does this product have a better, more user-friendly interface compared to the dial-and-button-covered interface of most washing machines today, but the touch interface adds new functionality to the appliance. With the washer connected via WiFi or a 3G network, the user could download laundry-specific applications such as a stain-removal guide, a laundry-symbol decoder, and even an e-commerce portal for purchasing laundry supplies. The user could also install applications for other home-related functions such as lighting control or energy monitoring. All of these possible features create new opportunities and potential revenue streams for the appliance maker, product user, application developers, and numerous other third parties. ■



SENSING AMERICAS, INC.

THE STANDARD IN MEASURING  
LIGHT

**How low can they go?**  
0.0005 cd/m<sup>2</sup> Low.

CS-2000A CA-2000

Measure color distribution, uniformity, ultra-low luminance and more.  
See the difference for yourself at [www.konicaminolta.com/sensingusa](http://www.konicaminolta.com/sensingusa)

See Us at Display Week 2010 in Seattle

# Green Technology

*For the first time in the history of the Symposium, the Society for Information Display has designated a group of special sessions to explore green technologies in the display industry. These include Novel Power-Reduction Techniques, Green Technologies in Display Manufacturing, Low-Power E-Paper and Other Bistable Displays, Power-Saving Device Designs, and Green Technologies in Active-Matrix Devices.*

by Don Carkner

**R**EDUCING the environmental impact of new display components, including a focus on lower power consumption and sound recycling practices, is now the mission of almost every participant in the display industry. It is not only good business to give consumers and system designers what they want, it is also rapidly becoming mandated in many jurisdictions. If a company is not thinking “green” today, it is not really engaged in its marketplace or preparing itself for the future. Accordingly, Display Week’s 2010 technical program committee decided to create a new forum to help bring the display industry’s green technology ideas to light, and the focus is expected to be enthusiastically received by conference goers eager to find new ways to conserve energy in terms of both process and product.

## Highlights and Trends

The Symposium will contain five sessions in the Green Technology track, with 20 papers covering topics ranging from power-saving circuitry and drive techniques to materials and energy reductions during manufacturing to

---

*Don Carkner is Principal Technologist for CH2M Hill, a member of the SID program selection Display Manufacturing subcommittee, and Program Vice-Chair for Green Technologies for SID 2010. He can be reached at don.carkner@ch2m.com or (503) 736-4318.*

novel device structures that allow higher efficiency operation. A strong trend is under way to adopt light-emitting diodes (LEDs) as a replacement light source for backlight units in liquid-crystal displays (LCDs), both for power reduction and for the very thin packages that such designs enable (see Fig. 1), with many observers predicting complete penetration within a few short years. Another trend in the making is evidenced by the emergence of energy-, material-, and biomass-saving bistable e-paper displays, as the publishing industry prepares to undertake the massive transition from being paper-based to electronic.

## Featured Papers

The Display Week sessions will feature several overview presentations on green technology and design in the display industry, from marquee manufacturers such as Samsung, AUO, and Philips. An invited paper (Session 9) from Dr. Jun Souk of Samsung, “Green Technology in LCDs,” will provide a comprehensive overview of the current status and future prospects for green technologies and trends in the LCD manufacturing industry.

Sharp will present a paper, “Power-Efficient LC TV with Smart Grid Demand Response

*Fig. 1: Samsung’s LED9000 is an example of a super-thin LED-edgelit LCD TV that is designed to be energy efficient. Image courtesy Samsung.*

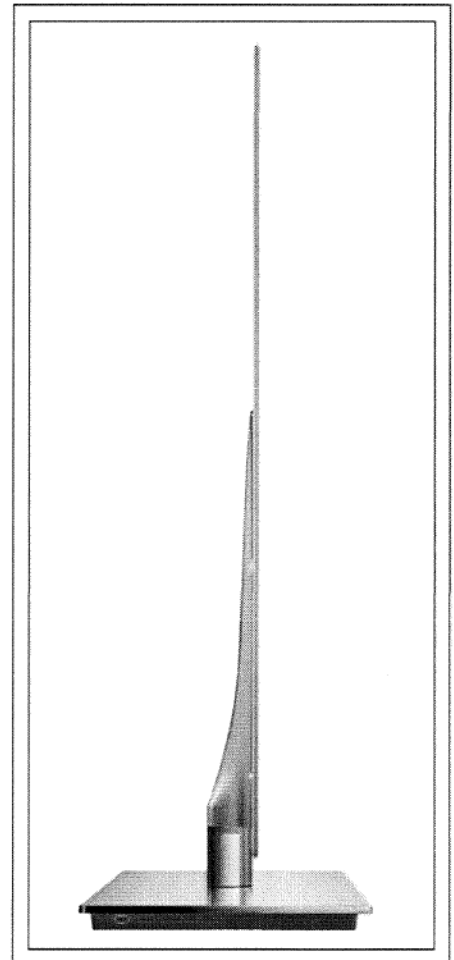

Functionality," by Louis Kerofsky, on the hot topic of Smart-Grid functionality. There will also be papers on novel LED-backlight technologies from Chiao Tung and Chung Hua Universities. New power-saving drive techniques will be discussed by LG Display, and AMOLEDs, another topic that looms large in terms of future power reduction, by Universal Display Corp. (UDC). There will also be a selection of papers from Europe and the U.K. on novel e-paper approaches.

Seiko Amamo from the Semiconductor Energy Lab in Japan will discuss low-power operation using the interesting new IGZO-based amorphous-oxide TFT device. An-Thung Cho from AUO will talk about two forward-looking technology developments – in-cell light sensing and in-cell solar power generation – imagine a display that generates its own power!

#### The Case for Green

We seem to be immersed daily in exhortations on the need to reduce emissions and conserve resources, and many people have taken such advice to heart by altering patterns in their daily lives. Now these concerned consumers are taking the next step, which is holding manufacturing companies and the devices they sell accountable in a similar way. Industry players are developing strategies, techniques, and trends that are being used in order to meet both consumers' and the shareholders' requirements, and these sessions will allow such players to educate the industry on their plans and efforts. ■

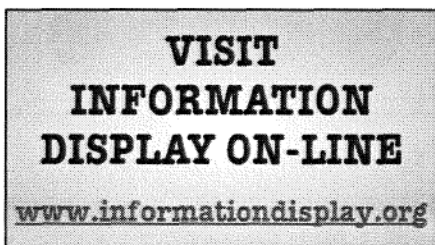

# EXPERIENCE

DONTECH'S BROAD SPECTRUM OF OPTICAL

SOLUTIONS

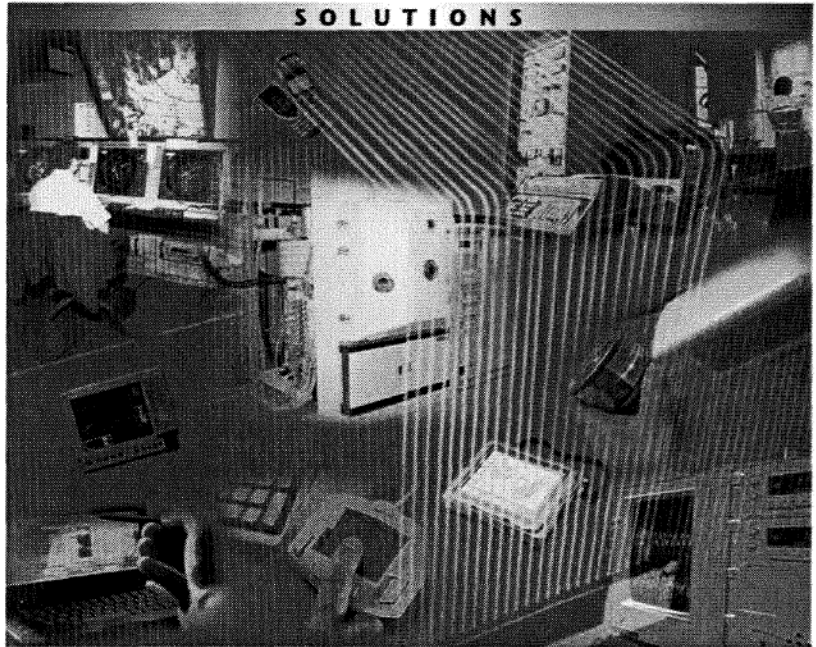

EMI/RFI • CONTRAST ENHANCEMENT • AR/AG COATINGS

#### PRODUCTS FOR ELECTRONIC DISPLAY APPLICATIONS

- Optical filters and laminates – glass, acrylic polycarbonate, TAC, PET substrates
- EMI/RFI shielding filters – transparent conductive coatings and optical fine wire mesh enhanced to maximize light transmission
- VARGard™ – anti-reflective films, conductive films
- Thermal management – ThermoKlear™ transparent heaters, IR filters, absorptive coatings
- Nightvision compatible filters, hot mirrors, minus blue filters, band pass, band rejection coatings
- Contrast enhancement filters, polarizers
- Dontech EDS – custom display enhancements via filter/bezel and touch screen assembly, film laminations, optical bonding, active/passive enhancements

*Since 1971 Dontech, Inc. has been designing and manufacturing optical and EMI/RFI filter solutions to enhance electronic displays. For optical applications ranging from the ultraviolet to the infrared or for EMI/RFI shielding from 10 kHz through 20 GHz, Dontech provides unmatched capabilities.*

Dontech, Inc., 700 Airport Blvd., Doyelstown, PA 18902  
215-348-5010 • Fax 215-348-9959 • [www.dontech.com](http://www.dontech.com)



See Us at Display Week 2010 in Seattle

# Touch Takes Off at Display Week 2010

*Due to the large number of touch-related symposium papers and exhibitors at last year's Display Week, the Society for Information Display has inaugurated sessions devoted exclusively to touch technology in 2010. The sessions are: Touch Technology Development, Multi-Touch Systems and Developments, and Display-Embedded Touch Solutions. There is also a touch poster session with nine presentations.*

by Jenny Donelan

**I**NTEREST in touch-interface technology has skyrocketed during the last 2 years at Display Week. In 2009, 54 exhibitors were on-hand to show touch screens, controllers, or other touch-related products and services, (representing more than 25% of total exhibitors at the show). Prior to 2009, the number of touch papers submitted each year could be counted on the fingers of one hand. In 2009, there were 16<sup>1</sup> papers and in 2010 there will be 21 (including posters). All this activity is a bit akin to a gold rush, in that there's money to be made and lots of people are after it – if only they can find the right spot (*i.e.*, the best solutions or killer application). At this time, these solutions, including iterations of technologies, such as resistive, capacitive, acoustic wave, and more, are numerous and, in the end, some will undoubtedly achieve more traction than others. Practically everyone involved in touch technology can find something promising this year at Display Week 2010, which will be a fascinating stage on which many of these companies and technologies play out.

"There is incredible interest and expansion in the touch market right now," says Bob Senior, an Executive Vice President with Noise Limit and SID Program Vice Chair for Touch. But why now? Touch has, after all, been around about as long as there have been

*Jenny Donelan is the Managing Editor of Information Display magazine.*

personal computers; even multi-touch is about a quarter-century old. While the technology has been used for many years in applications such as banking ATMs and educational platforms, it was not as much of a draw for personal computers and other devices until a couple of recent commercial implementations took hold. One is obviously Apple's iPhone (see Fig. 1) and other portable devices that use multi-touch. Another is Microsoft's support for multi-finger touch in the user interface for Windows 7, as well as its Surface computing. Senior also cites Hewlett Packard's TouchSmart technology, incorporated in its line of TouchSmart PCs, as a factor in raising the general awareness of touch.

Clearly, consumers want touch and manufacturers want to provide it. The attachment rate, or percentage of devices that ship with touch, has multiplied greatly over the last couple of years, according to Senior. One of the ongoing challenges for this technology, however, is finding a solution that works across the widest possible range of display devices. "There is no silver bullet technology," says Senior. Accordingly, Display Week 2010 will be the ideal venue to examine the evolution and potential of the different currently available technologies.

## A Touching Story

Starting off the touch sessions will be a *de facto* keynote session, an invited paper from Microsoft Research's Bill Buxton. His pre-

sentation, "A Touching Story: A Personal Perspective on the History of Touch Interfaces

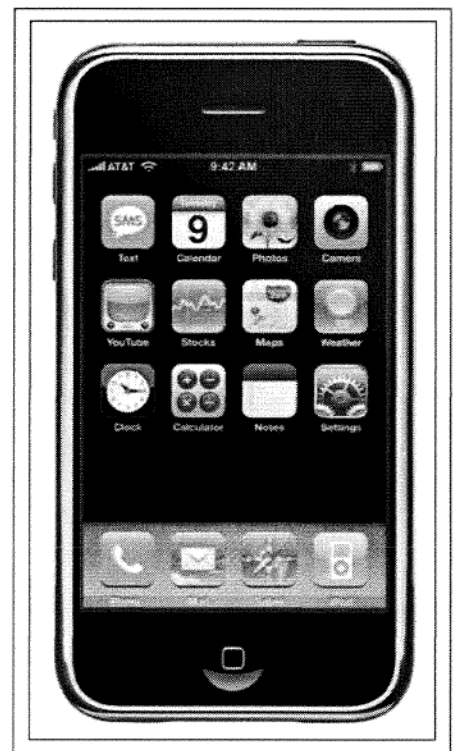

*Fig.1: The use of multi-touch in the iPhone fired the public imagination and helped bring about general acceptance of the multi-touch interface. Image courtesy AT&T.*

Past and Future” will provide an excellent overview of the factors leading up to today’s touch revolution and will include a sub-theme on the nature of innovation itself. Buxton’s paper will trace the long (40-plus years) history of touch, including the story behind the “pinch-gesture” used to scale photographs, etc., which was first demonstrated in 1983. He will report on touch screens that began to be developed in the second half of the 1960s, with early work being done by IBM, the University of Illinois, and in Ottawa, Canada. As he discusses solutions that were discovered decades ago, but have only come to the forefront now, he will explain that such a lengthy incubation time for the development of new technology is not at all unusual.

#### Multi-Touch and Embedded Themes

In terms of themes for submitted papers, both multi-touch and embedded touch were strong R&D subjects this year. Accordingly, each has a session dedicated to it. Multi-touch is

“hot,” of course, and embedded or “in-cell” touch – incorporating the touch into the display itself rather than as an overlay – “that’s the nirvana of touch,” says Senior. In-cell touch will enable designs that are more elegant – and less expensive. For more about in-cell technology, see “LCD In-Cell Touch” in this issue. The multi-touch session includes the invited papers, “What Multi-Touch Is All About,” by Jeff Han from Perceptive Pixel, and “In-Cell Embedded Touch-Screen Technology for Large-Sized LCD Applications” by Seiki Takahashi from Samsung. The embedded session has six papers, including “Novel LCD with a Sensing Backlight” by Kwonju Yi from Samsung Electronics and “Embedded Si-Based Photonic Sensor in TFT-LCD Technology Integrated as a Multi-Function Touch-Input Display” by An-Thung Cho from AU Optronics Corp.

Although Display Week 2010’s technical symposium is rich with offerings in many areas, attendees should be sure to attend at

least a few of the touch sessions because the year to come will undoubtedly be a pivotal one for touch. The featured papers will describe not only where the technology is headed, but where it came from, and how certain types of touch solutions may rise to the top over the next few years.

#### References

<sup>1</sup>G. Walker, “Display Week 2009 Review: Touch Technology,” *Information Display* (August 2009). ■



Have you forgotten about this issue?  
Log onto [informationdisplay.org](http://informationdisplay.org) and click “ID Archive.”

Information Display August 2009 Vol. 25, No. 08

Display Week 2009 Dazzles San Antonio

COMMERCIAL SUCCESS OF FLEXIBLE AND E-PAPER DISPLAYS

EMERGING LCD PRODUCTS AND TECHNOLOGIES

IMPROVED OLED DISPLAYS

TOUCH TECHNOLOGY ABOUNDS AT DISPLAY WEEK 2009

PICO-PROJECTION TECHNOLOGY

Plus PROJECTION TECHNOLOGY BEHIND BEIJING'S SUMMER GAMES

2009 DIRECTORY OF THE DISPLAY INDUSTRY

Journal of the SID August Preview

Touchscreen Tethered Stylus

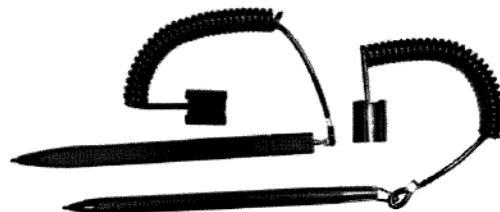

or

Touchscreen Stylus Tethers

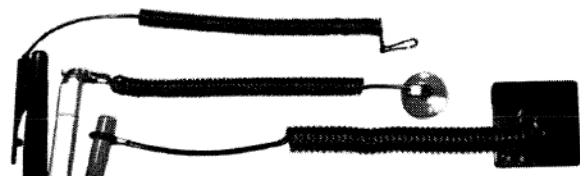

We manufacture both!  
... stock & custom designs & colors

“We securely connect things to things!”

Slencil®

Slencil Company  
Orange MA 01364-0210 USA  
email: [sales@slencil.com](mailto:sales@slencil.com)  
T:+978 544-2171 F:+978 544-2812

made in USA

See Us at Display Week 2010 in Seattle

## LatinDisplay 2009

by Daniel den Engelsen

LatinDisplay 2009, the premier Society for Information Display conference in the Southern Hemisphere, took place in São Paulo, Brazil, on November 16–19, 2009. The venue for the third annual event was the Perdizes campus of the Pontifícia Universidade Católica de São Paulo (PUC-SP), where the organizers held a symposium with oral presentations, a poster session, and an exhibition run in parallel to the conference. The Display Escola (Display School), a special program for those who wanted to learn more about displays, took place on November 19 at another campus of PUC, having about 35 people in attendance.

LatinDisplay 2009 had approximately 280 participants over the 3 days – a record for this conference. LatinDisplay has definitely come of age as a member of the family of SID conferences. There are several reasons behind this growing popularity. First, LatinDisplay has a unique conference formula; it is basically a one-track conference with no parallel sessions, featuring oral presentations by famous display experts from all over the world. Second, the speakers are carefully selected and instructed to present topics in a way that will be of interest to a broad audience of attendees, including students, company managers, university professors, bankers, and government authorities, as well as experts from display-related institutes and industries.

The highlighted areas at LatinDisplay 2009 were OLEDs, e-Readers, and displays for medical applications. Apart from a gripping lecture by Dr. Manju Rajeswaran, Senior Scientist at Kodak, on the analysis of OLED materials, the focus on OLEDs was on lighting applications. Dr. Gopalan Rajeswaran, Vice President of Moser Baer, reviewed recent developments in organic solid-state lighting and Dr. Tom Munters, Product Manager at Philips Lighting for OLED-based lighting, described Philips's activities in this field.

Ken Werner, Senior Analyst at Insight Media, described the developments in the field of e-paper, notably e-Readers. The avalanche of products now on the market demonstrates that e-paper technology is maturing.



Shown at far right during the opening ceremony of LatinDisplay 2009 is Dr Victor Pellegrini Mammana, chairman of the conference.

The third highlight was a presentation from Dr. Adi Abileah, Chief Scientist at Planar Systems, on displays for medical applications. His presentation was also the perfect introduction for a subsequent panel discussion on displays and information systems for health-care and hospitals. That discussion featured Ken Werner, John Jacobs of DisplaySearch,

Gabriel Marcu of Apple Computers, Adi Abileah, and Cecil Cho of USP in Brazil.

In addition to these highlights, there were many other invited lectures with content that was of interest to specialists as well as a broad audience. The lively Q&A sessions after the presentations showed that audience members were highly engaged. Perhaps LatinDisplay's

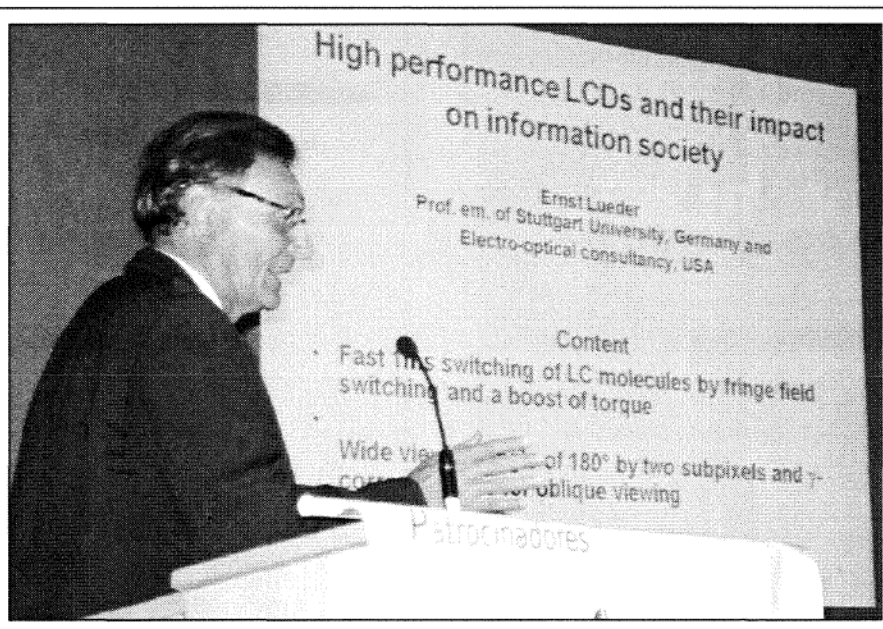

Dr. Ernst Lueder of Stuttgart University begins his lecture on high-performance LCDs at LatinDisplay 2009.

## SID news

successful, one-track formula is ready to be copied by other chapters of the SID.

It should be noted that a second attractor for LatinDisplay is the current policy of the Brazilian government to attract the display industry to Brazil to counteract a trade deficit of about US\$2 billion due to huge panel imports. The policy and financial instruments that are available in Brazil to attract display-related industry were presented by Dr. Margarida Baptista of the Banco Nacional de Desenvolvimento Econômico e Social (BNDES) and by Dr. Pedro Alem of the Agencia Brasileira de Desenvolvimento Industrial (ABDI).

The poster session during LatinDisplay 2009 (40 posters in total) was a good opportunity for young scientists to show their newest results in supporting technologies for displays, solar cells, and lighting. Awards were given for both the best student and non-student posters.

The exhibition parallel to LatinDisplay 2009 was modest, with only 16 booths. Nevertheless, the central location of the venue supported networking activities between the participants, and for this reason the exhibition was an attractive place to show services and products.

Finally, the hospitality of the Brazilians, especially the hostess of LatinDisplay 2009, Professor Alaide Pellegrini Mammana, amid the warm Brazilian culture, once again provided the finishing touch to a successful LatinDisplay.

Please visit the Web site of LatinDisplay 2009 to learn about forthcoming LatinDisplay conferences at <http://www.brdisplay.com.br/latindisplay>. LatinDisplay 2010 has been scheduled for November 16-19. Alaide and Victor Pelligrini Mammana look forward to welcoming you to Brazil for the next and most exciting LatinDisplay yet. ■

*Daniel den Engelsen is Chairman of the Program Committee of LatinDisplay 2009.*

**For daily display  
industry news, visit**

**[www.informationdisplay.org](http://www.informationdisplay.org)**

## guest editorial

*continued from page 4*

the user needs. In my mind's eye, I can see what I like to call the "psychic touch screen™." *It knows what the user wants, and it just does it.* It doesn't care how many fingers are used, how dry the fingers are, how hard or soft or quickly or slowly the screen is touched, where it's touched, what it's touched with, whether a hand (and maybe also a beer can) is resting on the screen, whether the device is in bright sunlight, or anything else. When users are interacting with touch-screen-equipped devices, they do not want to be thinking about touch or fingernails or anything related to the touch screen. They just want to use their devices! We have a long way to go to get to that point, but that's partly what the current excitement of the touch industry is all about. Touch is accelerating and exhilarating.

This issue of *Information Display* focuses on touch. In the Frontline Technology article "LCD In-cell Touch," my colleague Mark Fihn (Veritas et Visus) and I explore the latest status of LCD in-cell touch, the holy grail of touch for the past 7 years. In the next Frontline Technology article, "Projected-Capacitive Touch Technology," Gary Barrett (Touch International) and Ryomei Omote (Nissha Printing) together provide a thorough explanation of projected-capacitive touch technology, currently one of the hottest topics in touch. In this issue's Display Marketplace article, Jennifer Colegrove (DisplaySearch) delineates the current state of the touch market, as well as recent events in a half-dozen touch technologies. In the Enabling Technology article, "Touch Screens and Touch Surfaces Are Enriched by Haptic Force-Feedback," Bruce Banter (Tech-D-P) describes several new technologies that are being employed in haptic (force-feedback) touch screens, as well as what's happening in automotive implementations. And in a second Enabling Technology article, Mark Fihn (Veritas et Visus) and I look beneath the surface of Microsoft's Surface product and other similar vision-based touch technologies. Wrapping up this issue is Mark Hamblin's (Touch Revolution) Making Displays Work for You article, in which he explains why touch makes sense as a replacement for conventional button-and-switch interfaces and provides some eminently practical guidelines for applying touch in those environments.

I hope that you find the articles in this issue so interesting and exciting that you'll be eager to join me and the rest of the touch industry in the pursuit of the psychic touch screen! ■

*Geoff Walker is the Marketing Evangelist & Industry Guru at NextWindow, the leading supplier of optical touch screens. He is a recognized touch-industry expert who has been working with touch screens for 20 years. He can be reached at 408/506-7556 and [gwalker@nextwindow.com](mailto:gwalker@nextwindow.com).*

## president's corner

*continued from page 6*

aggressive, and viewed by some as "wishful thinking." There was certainly no consensus that these predictions could be met.

Now that it's 2010, we can look back and see that these predictions were not only true, but could have been more aggressive! According to market research firm DisplaySearch, unit shipments reached 100 million in 2008 (2 years earlier than President Lee predicted), the \$1000 retail price is available for 46-inch panels (32-inch panels are available for less than \$500!), and AMLCDs have far more market share in televisions than all competing technologies combined. Digital signage is an exciting new application area, 70-inch LCD panels are being sold through retail channels, and Gen 8 through Gen 10 fabs now represent the state of the art.

All participants in the AMLCD industry must take credit for this achievement; Mr. Lee himself declared that success would require innovation and investment from across the entire industry. Still, this was a bold prophecy presented over 5 years ago by a true visionary, and one that has unfolded despite the doubts of many at the time.

In this 2010 year, I will note that SID has another senior executive from Samsung, Dr. Sang Soo Kim, providing a keynote address. Indications are that he will also be addressing the growth potential of another emerging technology – this time organic light-emitting-diode (OLED) displays. I, for one, will be very keen to hear his predictions for the future and to see if history can repeat itself. ■

# Official SID Housing Request Form: Display Week

Seattle, Washington May 23 - 28, 2010

The official housing closing date is April 23rd, 2010. If you have not made reservations by this date, contact Globetrotter Travel, and every effort will be made to secure accommodations for you.

**Fill out this form completely and mail or fax to:**

Globetrotter Travel Management Services

18121 Georgia Avenue

Suite 104

Olney, Maryland USA 20832-1437

**Toll Free U.S. and Canada 888-296-2967**

**International Callers 301-570-0800**

**PRESS 2 for Hotel or PRESS 1 for Flight Information**



**Fax**  
301-570-9514



**Email**  
sid@globetrottermgmt.com



**Online Reservations and Hotel Maps/Descriptions**  
www.globetrottermgmt.com/sid

| Hotel                                    | Single   | Double   |
|--|----------|----------|
| 1) Red Lion Hotel                        | \$187.00 | \$187.00 |
| 2) Sheraton Seattle (Headquarters Hotel) | \$199.00 | \$199.00 |
| <b>Club Level:</b>                       |          |          |
| 3) Grand Hyatt                           | \$229.00 | \$229.00 |
| 4) Hyatt Olive 8                         | \$209.00 | \$229.00 |

15.6% Occupancy and sales tax not included in room rates (Subject to change without notice)

### SID HOUSING GUIDELINES

In order to keep facility fees down, the Society for Information Display arranges contracts that combine rental of convention facilities and guarantee of a certain number of hotel room-nights at convention hotels. SID Symposium participants can help keep registration fees down this year and in the future by registering and staying in hotels listed in the SID registration information. Nevertheless, in response to the current economic situation, SID has relaxed its deadlines for hotel reservations to provide its attendees flexibility in scheduling their participation.

### IMPORTANT DATES

|   |   |
|---|---|
| April 23, 2010 - Name receipt deadline          | Globetrotter must have received the names of the occupants for each room reservation. Name changes are permitted, without charge up to the date of check in. Room reservations without named occupants will be cancelled.           |
| April 30, 2010 - First night guarantee deadline | Up to this deadline, reservations may be cancelled without penalty. Reservations still in force on this date will be charged a one night, non-refundable deposit of room rate plus tax.   |
| 72 hour - Full reservation guarantee deadline   | For any cancellations or date changes made within 72 hours of the checkin date, a full charge for all reserved room nights plus tax will be applied. The one-night deposit previously charged will be credited against this charge. |

**Exhibitor**  **Attendee**

**Contact Information:**

Name: \_\_\_\_\_  
 Company: \_\_\_\_\_  
 Address 1: \_\_\_\_\_  
 Address 2: \_\_\_\_\_  
 City \_\_\_\_\_ State \_\_\_\_\_ ZIP \_\_\_\_\_  
 Country \_\_\_\_\_  
 Phone: \_\_\_\_\_  
 Fax: \_\_\_\_\_  
 E-Mail \_\_\_\_\_

**Occupant Information: (Each line represents 1 room unless otherwise specified)**  
**Preferred Hotel Choice: (1) \_\_\_\_\_ (2) \_\_\_\_\_ (3) \_\_\_\_\_**

| Smoking | Number of People | Number of Beds | Name(s) of Occupant(s) | Arrival Date | Departure Date |
|---------|------------------|----------------|------------------------|--------------|----------------|
|         |                  |                |                        |              |                |
|         |                  |                |                        |              |                |
|         |                  |                |                        |              |                |
|         |                  |                |                        |              |                |

Special Requests (please circle): Roll-a-way Handicapped Accessible Other \_\_\_\_\_  
 Valid Credit Card with expiration date through 7/2010 required.

Credit Card Number: \_\_\_\_\_

Exp Date: \_\_\_\_\_

Cardholder's Name: \_\_\_\_\_

Cardholder's Signature: \_\_\_\_\_

Check Enclosed: \_\_\_\_\_ Check# \_\_\_\_\_



GLOBETROTTER  
Travel with the Experts™



GLOBETROTTER  
Travel with the Experts™



# Society for Information Display 2010 Seattle Hotel Map

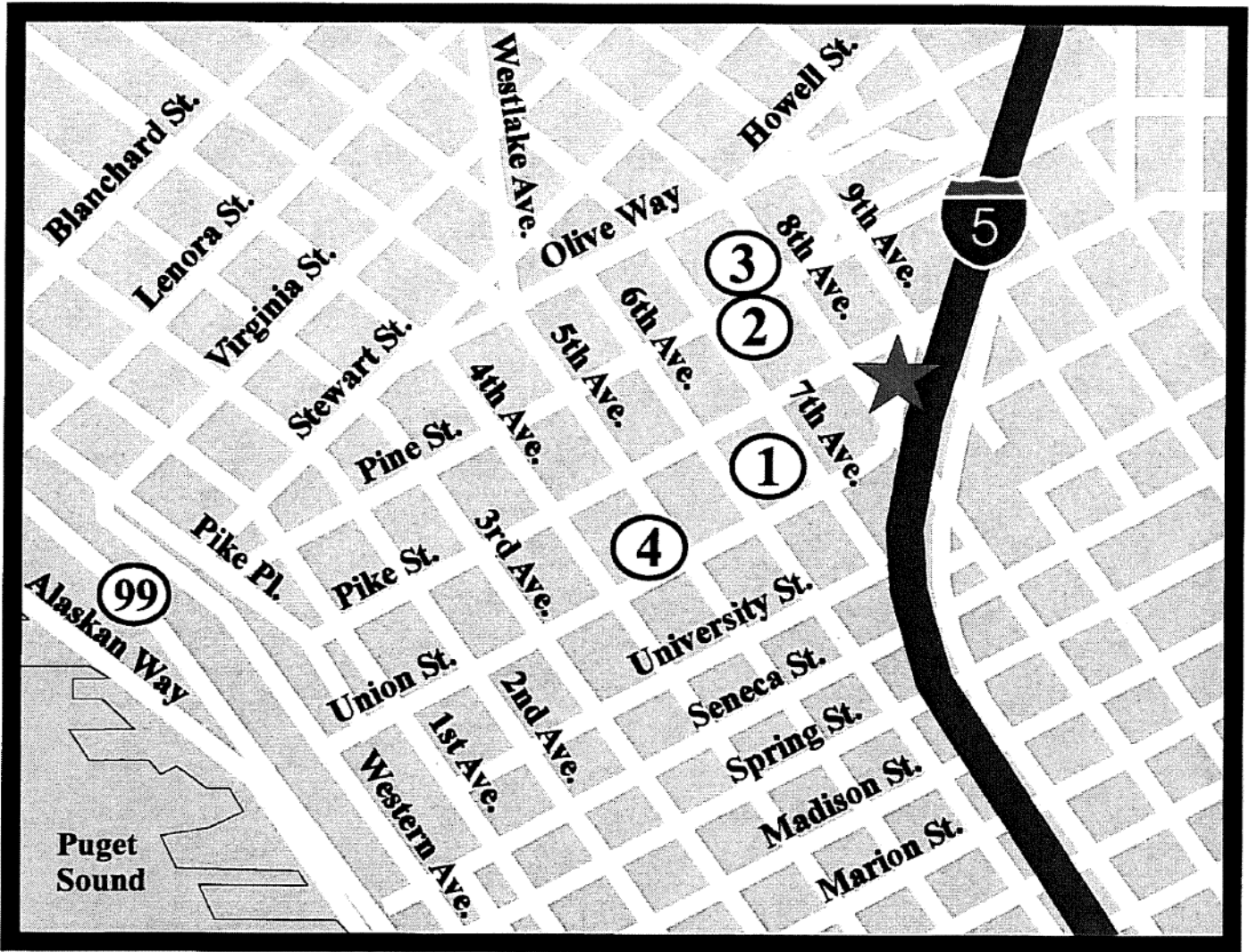

- ★ **Convention Center**
- ① **Sheraton**
- ② **Grand Hyatt**
- ③ **Hyatt Olive 8**
- ④ **Red Lion Hotel**

## sustaining members

Advitech  
 Applied Concepts, Inc.  
 Astra Products, Inc.  
 AU Optronics Corp.  
 autronic-Melchers GmbH  
 BigByte Corp.  
 California Micro Devices  
 CDT, Ltd.  
 Chi Mei Optoelectronics Corp.  
 Chunghwa Picture Tubes, Ltd.  
 Corning Japan K.K.  
 CTS - Computer Technology Solutions  
 Cytec Industries, Inc.  
 Dawar Technologies, Inc.  
 DisplaySearch  
 Dotech, Inc.  
 DTC/TRI  
 Endicott Research Group, Inc.  
 ENEA  
 Epoxy Technology  
 FIMI  
 Global Display Solutions  
 IGNIS Innovation, Inc.  
 Industrial Electronic Engineers, Inc. (IEE)  
 Industrial Technology Research Institute  
 Instrument Systems GmbH  
 IST (Imaging Systems Technology)  
 Japan Patent Office  
 Kent Displays, Inc.  
 Kuraray Co., Ltd.  
 LG Display Co., Ltd.  
 LXD, Inc.  
 Micronic Laser Systems AB  
 Microvision  
 Microvision, Inc.  
 Mitsubishi Chemical Corp.  
 Nano-Proprietary, Inc.  
 NEC Corp.  
 NextWindow  
 Nippon Seiki Co., Ltd.  
 Noritake Itron Corp.  
 Novaled AG  
 Optical Filters, Ltd.  
 Parker Chomerics/Silver Cloud  
 Planar Systems, Inc.  
 Plaskolite, Inc.  
 Polytronix, Inc.  
 QualComm  
 Quantum Data, Inc.  
 Radiant Imaging, Inc.  
 Schott North America, Inc.  
 Sharp Corp.  
 Tannas Electronics  
 Technology Research Association for Advanced Display Materials (TRADIM)  
 Teijin DuPont Films Japan, Ltd.  
 TFD, Inc.  
 TLC International  
 Toshiba America Electronic Components, Inc.  
 TPO Displays Corp.  
 Trident Microsystems, Inc.  
 Universal Display Corp.  
 Vestal Electronics A.S.  
 Westar Display Technologies  
 WINTEK Corp.

## index to advertisers

|                                   |    |                             |       |
|-----------------------------------|----|-----------------------------|-------|
| 3M.....                           | C4 | Konica Minolta.....         | 39    |
| Display Taiwan.....               | 25 | Laserod.....                | 25    |
| Display Week 2010.....            | 15 | Merek.....                  | 5     |
| Dotech.....                       | 41 | Microsemi.....              | 30    |
| ELDIM S.A.....                    | 15 | SID Hotel Reservations..... | 46,47 |
| EuropTec.....                     | 7  | SLENCIL Co.....             | 43    |
| Global Lighting Technologies..... | 7  | Thin Film Devices.....      | C3    |
| IRTTouch.....                     | C2 | Touch International.....    | 3     |

### Business and Editorial Offices

Palisades Convention Management  
 411 Lafayette Street, 2nd Floor  
 New York, NY 10003  
 Jenny Donelan, Managing Editor  
 212/460-9700  
 fax: 212/460-5460  
 jdonelan@pcm411.com

### Sales Office - Europe

George Isaacs  
 12 Park View Court  
 The Paddock, Eaton Ford  
 St. Neots, Cambridgeshire  
 PE19 7SD U.K.  
 +44-(0)-1480-218400  
 george@gandg.demon.co.uk

### Sales Office - China & Taiwan

Joy Wang  
 ACE Forum, Inc.  
 3F-2, No. 5, Sec. 1, Pa-Te Rd.  
 Taipei 100, Taiwan  
 +886-2-2392-6960 x204  
 fax: +886-2-2393-0667  
 joy@aceforum.com.tw

### Sales Office - U.S.A.

Palisades Convention Management  
 411 Lafayette Street, 2nd Floor  
 New York, NY 10003  
 Michele Klein, Director of Sales  
 212/460-8090 x216  
 fax: 212/460-5460  
 mklein@pcm411.com

### Sales Office - Korea

Jung-Won Suh  
 Sinsegi Media, Inc.  
 Choongmoo Bldg., Rm. 1102  
 44-13, Yoido-dong  
 Youngdung-gu, Seoul, Korea  
 +82-2-785-8222  
 fax: +82-2-785-8225  
 sinsegi-2@sinsegi-media.info

NATURE'S THIN FILMS LET YOU SEE...

OUR THIN FILMS MAKE WHAT YOU SEE  
LOOK BETTER



22.5" Capacitive Touch Panel  
With I.M.I.T.O.™

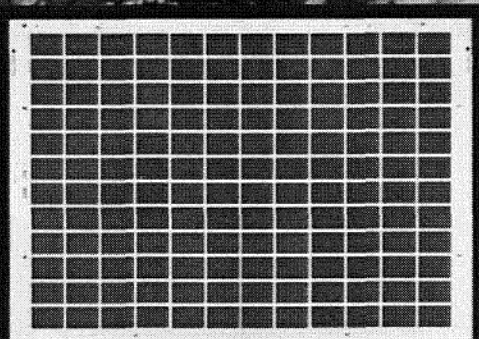

Capacitive Touch Panel on 3.5 Gen.  
With Black Mask

**Display Products: (All Ion Beam Sputtered)**

- ▶ Transparent Conductor ITO, IZO, AZO, FTO.  
with Lowest Surface Roughness
- ▶ I.M.I.T.O.™ to LC, Epoxy & Air
- ▶ Complete Coating Solutions For Your Innovations
- ▶ Patterning Transparent Conductors  
Metal & Oxides
- ▶ EMI/EMP Shield & Heaters
- ▶ Anti-Reflective & Hot Mirrors

Stock items for immediate delivery



**THIN FILM DEVICES, INCORPORATED**

1180 North Tustin Avenue • Anaheim, CA 92807

Phone: 714-630-7127 • Fax: 714-630-7119 • Email: sales@tfdinc.com

Visit our website: [www.tfdinc.com](http://www.tfdinc.com)

Acrosense Technology (Dti) • Taiwan Manufacturing  
Group International, LTD • China Manufacturing

TFD & Taiwan video tour: [www.youtube.com/tfdinc](http://www.youtube.com/tfdinc)

See Us at  
Display Week 2010  
in Seattle

# Notebooks with 3M Films Require Fewer Charges.

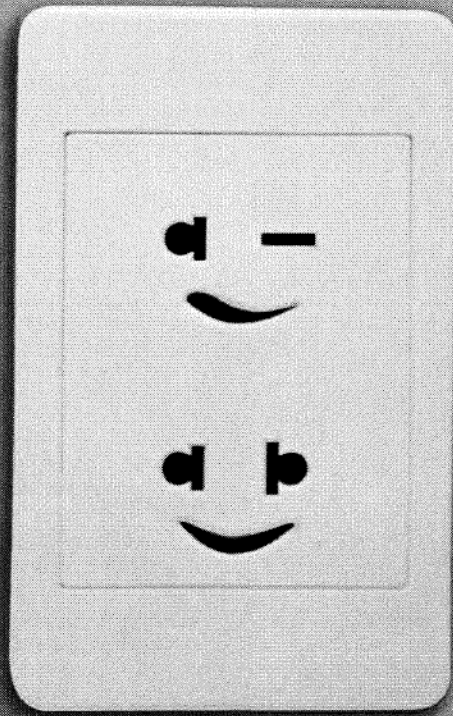

Maximizing battery life is a key goal for portable device manufacturers. 3M Display Films can help. For example, 3M offers film combinations that can increase notebook battery life 14 to 17 minutes beyond that of a standard film stack. With the ability to increase brightness up to 44% more than that provided by standard film stacks, these unique film combinations improve energy efficiency. The films enable notebooks, cell phones and other display devices to operate longer on battery power. Go to [vikuiti.com](http://vikuiti.com) to learn more about how 3M films can improve the energy efficiency of your LCDs.

Making displays more energy efficient since 1993.

[vikuiti.com](http://vikuiti.com)

See Us at Display Week 2010 in Seattle



3M, Vikuiti and the Vikuiti "Eye" Symbol are trademarks of 3M.  
© 3M 2010

# membership/subscription request

Use this card to request a SID membership application, or to order a complimentary subscription to *Information Display*.

## PROFESSIONAL INFORMATION

1. Are you professionally involved with information displays, display manufacturing equipment/materials, or display applications?

110  Yes 111  No

2. What is your principal job function? (check one)

- 210  General/Corporate/Financial
- 211  Design, Development/Engineering
- 212  Engineering Systems (Evaluation, O.C., Sols.)
- 213  Basic Research
- 214  Manufacturing/Production
- 215  Purchasing/Procurement
- 216  Marketing/Sales
- 217  Advertising/Public Relations
- 218  Consulting
- 219  College or University Education
- 220  Other (please be specific)

3. What is the organization's primary end product or service? (check one)

- 310  Cathode-ray Tubes
- 311  Electroluminescent Displays
- 312  Field-emission Displays
- 313  Liquid-crystal Displays & Modules
- 314  Plasma Display Panels
- 315  Displays (Other)
- 316  Display Components, Hardware, Subassemblies
- 317  Display Manufacturing Equipment, Materials, Services
- 318  Printing/Reproduction/Facsimile Equipment
- 319  Color Services/Systems
- 320  Communications Systems/Equipment
- 321  Computer Monitors/Peripherals
- 322  Computers
- 323  Consulting Services, Technical Management/Marketing
- 324  Education
- 325  Industrial Controls, Systems, Equipment, Robotics

- 327  Medical Imaging/Electronic Equipment
- 328  Military/Air, Space, Ground Support/Aeronautics
- 329  Navigation & Guidance Equipment/Systems
- 330  Oceanography & Support Equipment
- 331  Office & Business Machines
- 332  Television Systems/Broadcast Equipment
- 333  Television Receivers, Consumer Electronics, Appliances
- 334  Test, Measurement, & Instrumentation Equipment
- 335  Transportation, Commercial Signage
- 336  Other (please be specific)

4. What is your purchasing influence?

- 410  I make the final decision.
- 411  I strongly influence the final decision.
- 412  I specify products/services that we need.
- 413  I do not make purchasing decisions.

5. What is your highest degree?

- 510  A.A., A.S., or equivalent
- 511  B.A., B.S., or equivalent
- 512  M.A., M.S., or equivalent
- 513  Ph.D. or equivalent

6. What is the subject area of your highest degree?

- 610  Electrical/Electronics Engineering
- 611  Engineering, other
- 612  Computer/Information Science
- 613  Chemistry
- 614  Materials Science
- 615  Physics
- 616  Management/Marketing
- 617  Other (please be specific)

7. Please check the publications that you receive personally addressed to you by mail (check all that apply):

- 710  I.E. Times
- 711  Electronic Design News
- 712  Solid State Technology
- 713  Laser Focus World
- 714  I.E.E.E. Spectrum

I wish to join SID. Twelve-month membership is \$100 and includes a subscription to *Information Display Magazine* and on-line access to the monthly *Journal of the SID*.

I wish only to receive a **FREE** subscription to *Information Display Magazine* (U.S. subscribers only). Questions at left must be answered.

Signature \_\_\_\_\_

Date \_\_\_\_\_

Name \_\_\_\_\_

Title \_\_\_\_\_

Company \_\_\_\_\_

Department/Mail Stop \_\_\_\_\_

Address \_\_\_\_\_

City \_\_\_\_\_

State \_\_\_\_\_ Zip \_\_\_\_\_

Country \_\_\_\_\_

Phone \_\_\_\_\_

E-mail \_\_\_\_\_

Check here if you do not want your name and address released to outside mailing lists.

Check here if magazine to be sent to home address below: (business address still required)

\_\_\_\_\_

\_\_\_\_\_

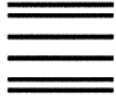

NO POSTAGE  
NECESSARY  
IF MAILED  
IN THE  
UNITED STATES

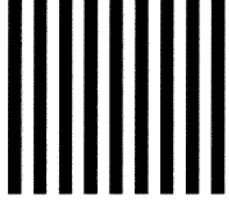

**BUSINESS REPLY MAIL**  
FIRST-CLASS MAIL PERMIT NO 692 CAMPBELL CA

POSTAGE WILL BE PAID BY ADDRESSEE

**ATTN: JENNY BACH  
SOCIETY FOR INFORMATION DISPLAY  
1475 S BASCOM AVE STE 114  
CAMPBELL CA 95008-9901**



*fold here*



*tape here*

