



(19) **United States**

(12) **Patent Application Publication**

**Frey et al.**

(10) **Pub. No.: US 2002/0165550 A1**

(43) **Pub. Date: Nov. 7, 2002**

(54) **DEVICES AND TECHNIQUES FOR A POSTERIOR LATERAL DISC SPACE APPROACH**

(76) Inventors: **George Frey**, Englewood, CO (US);  
**John L. White**, Bartlett, TN (US);  
**Steven D. DeRidder**, Bartlett, TN (US);  
**Harald Ebner**, Deggendorf (DE)

Correspondence Address:  
**Woodard, Emhardt, Naughton, Moriarty and McNett**  
**Bank One Center/Tower**  
**Suite 3700**  
**111 Monument Circle**  
**Indianapolis, IN 46204-5137 (US)**

(21) Appl. No.: **10/120,104**

(22) Filed: **Apr. 10, 2002**

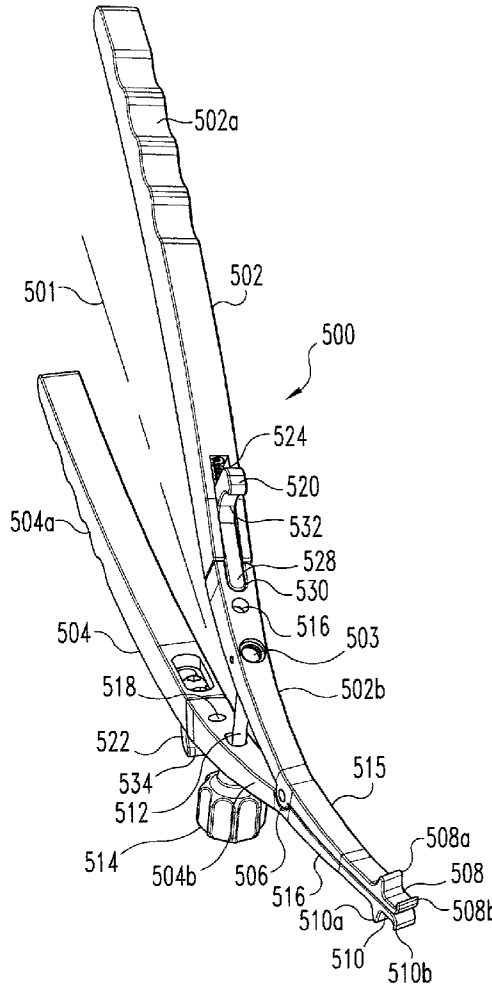
**Related U.S. Application Data**

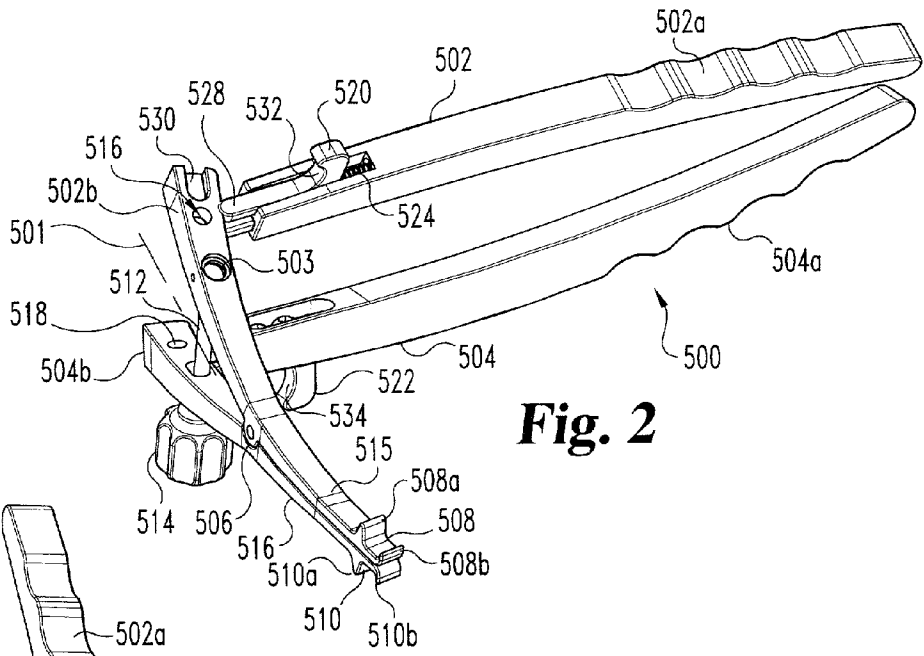
- (63) Continuation-in-part of application No. 09/858,197, filed on May 15, 2001, which is a continuation-in-part of application No. 09/694,521, filed on Oct. 23, 2000.
- (60) Provisional application No. 60/160,667, filed on Oct. 21, 1999.

**Publication Classification**

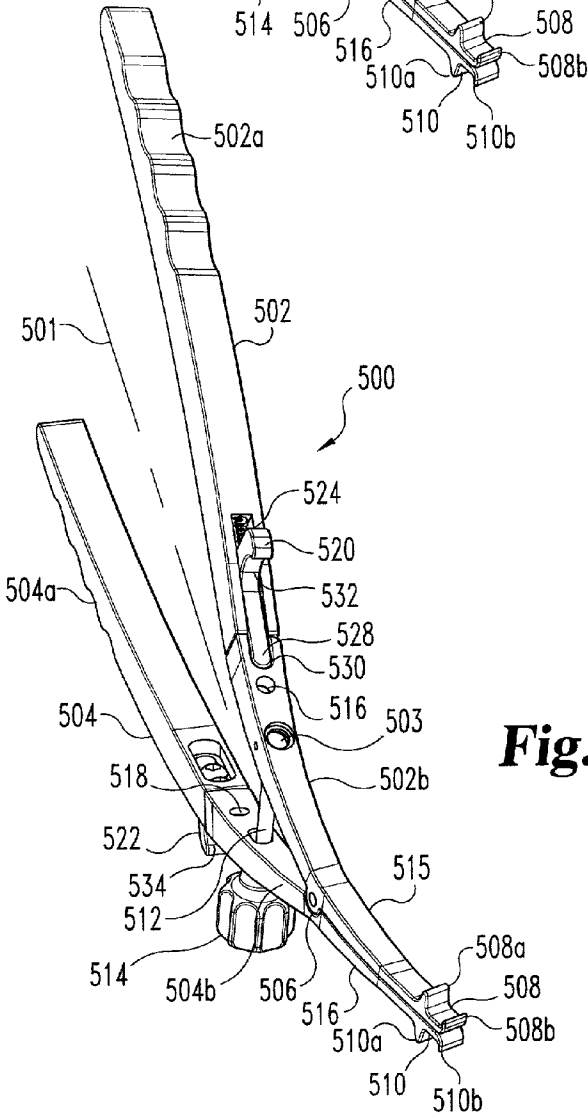
- (51) **Int. Cl.<sup>7</sup>** ..... **A61B 17/16**
- (52) **U.S. Cl.** ..... **606/85**

(57) **ABSTRACT**  
 This invention relates to devices and instruments for implant insertion through a posterior lateral opening to the disc space. The instruments include an implant inserter, and the devices include a spinal fusion implant engageable by the implant inserter. The implant provides bilateral support of the adjacent vertebrae when inserted into the disc space from a postero-lateral approach.

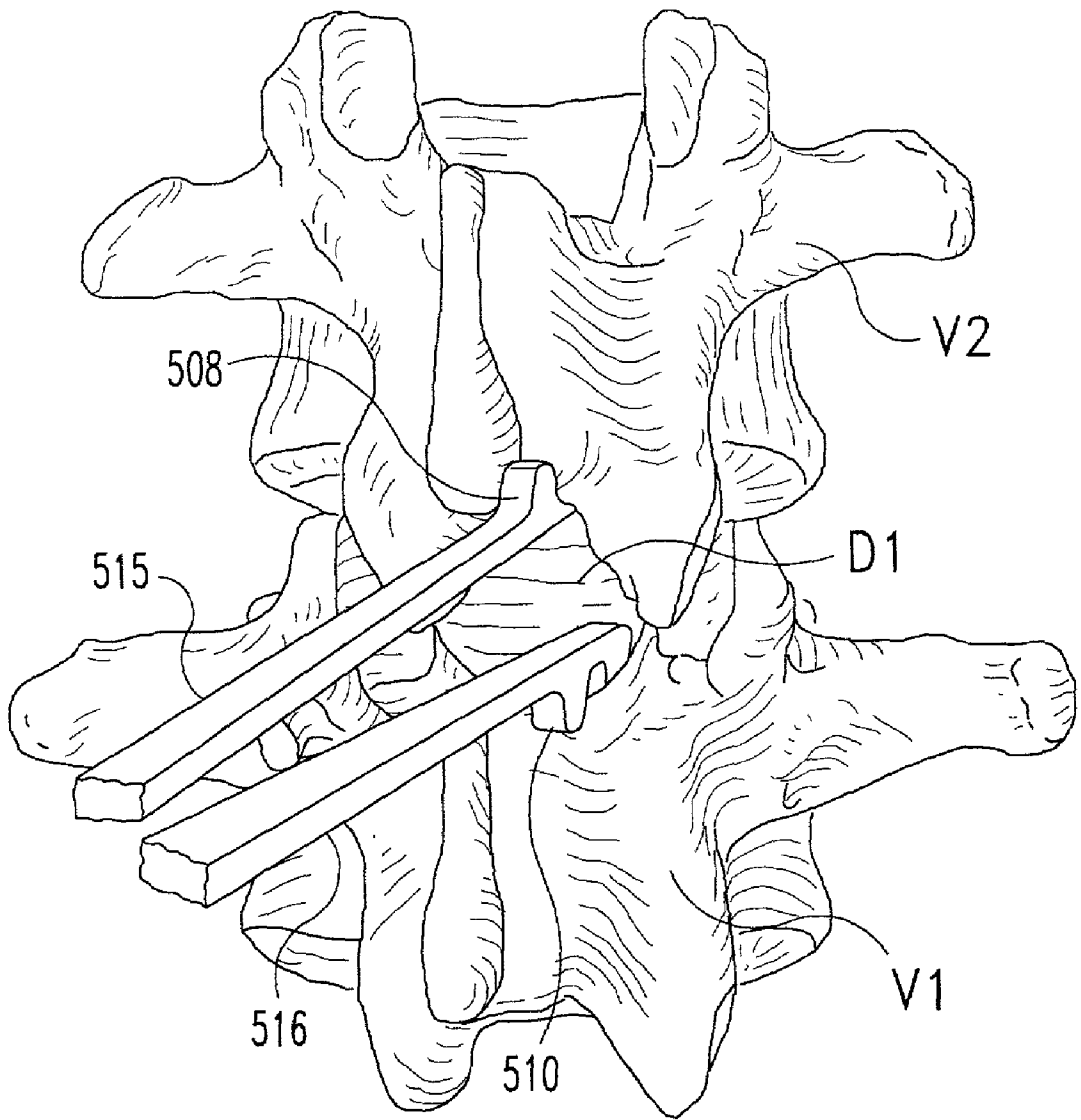




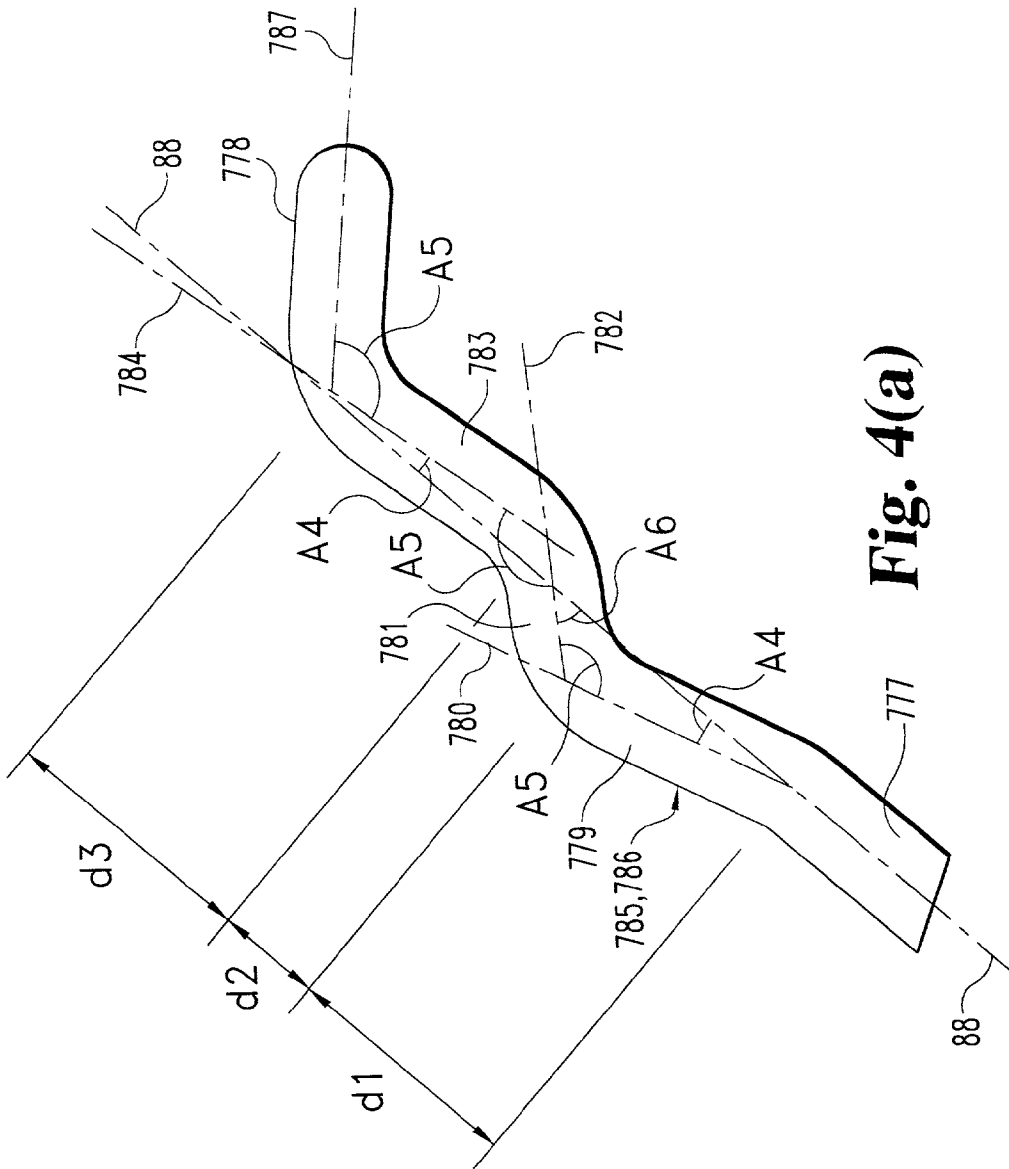
**Fig. 2**



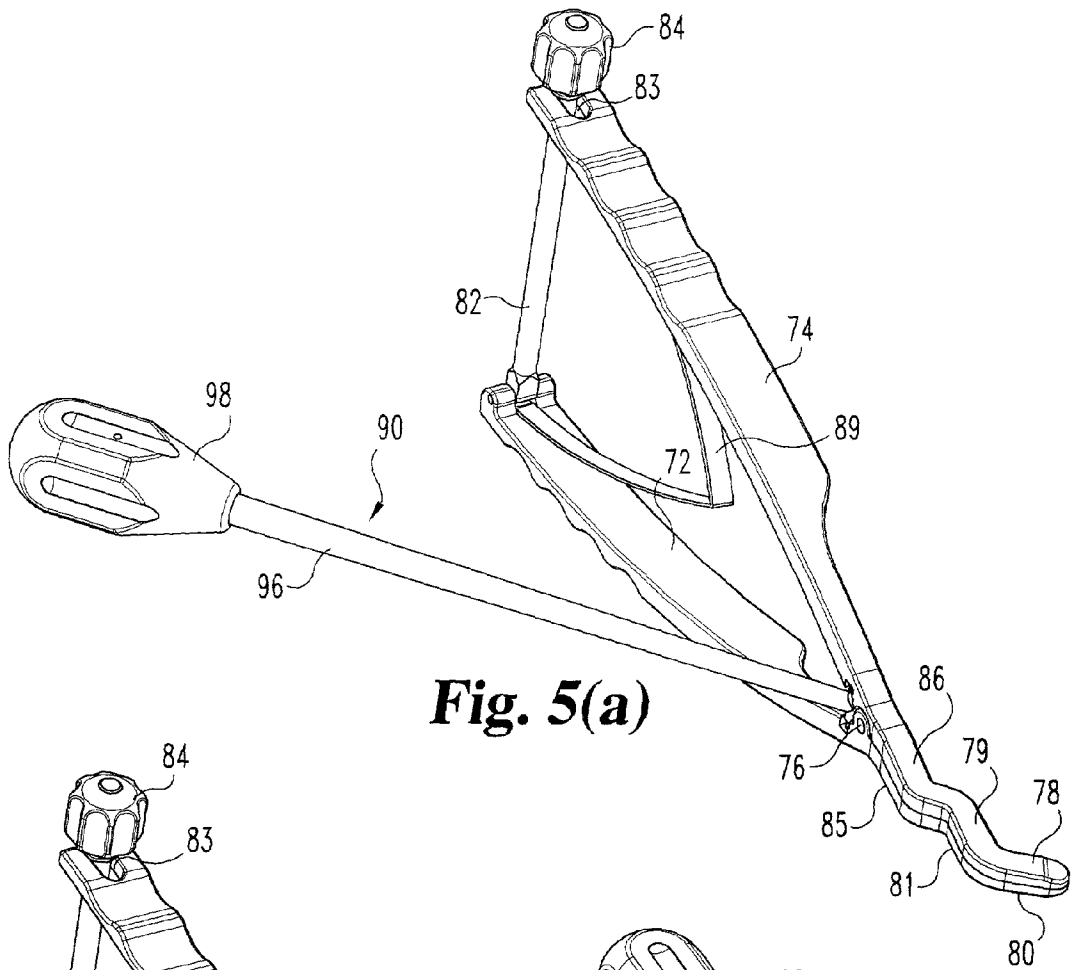
**Fig. 1**



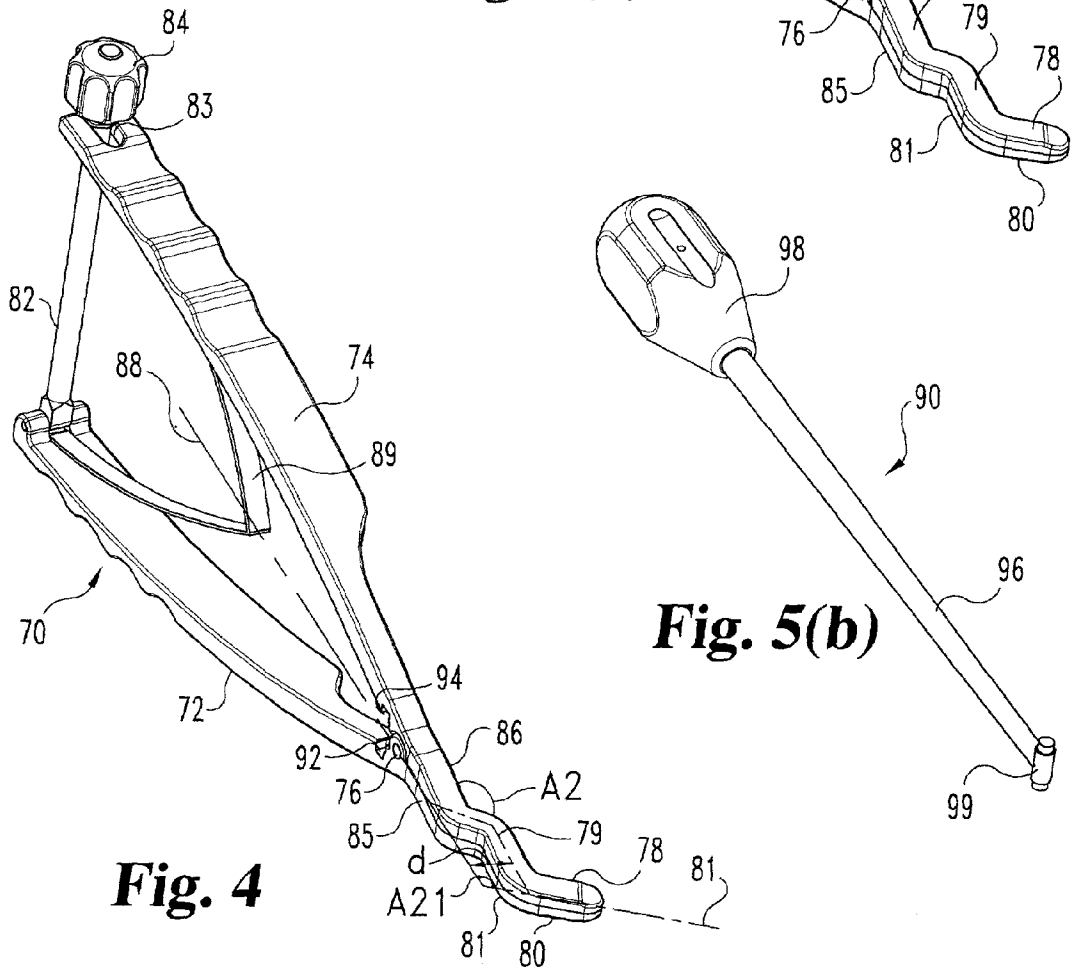
**Fig. 3**



**Fig. 4(a)**



**Fig. 5(a)**



**Fig. 5(b)**

**Fig. 4**

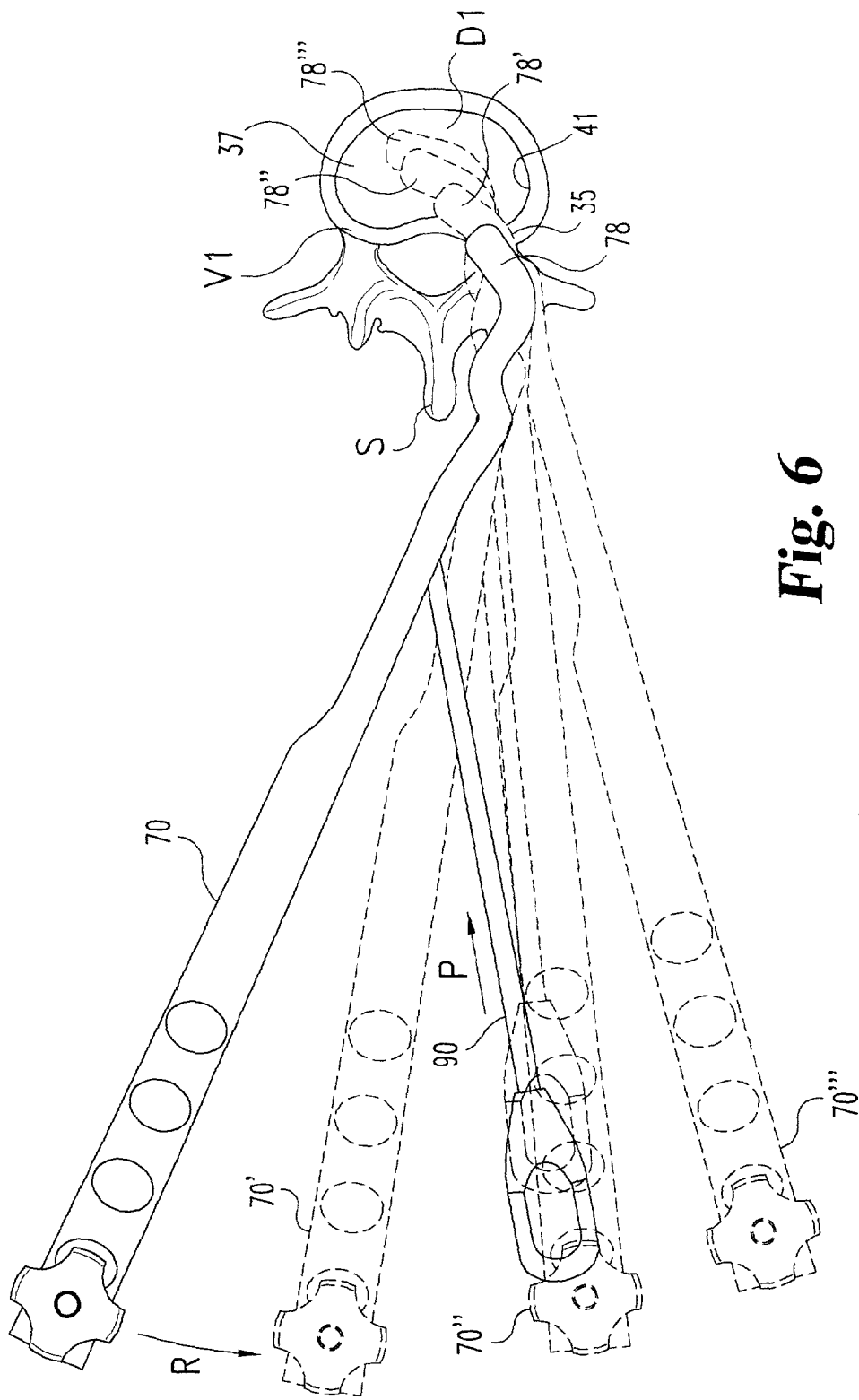


Fig. 6

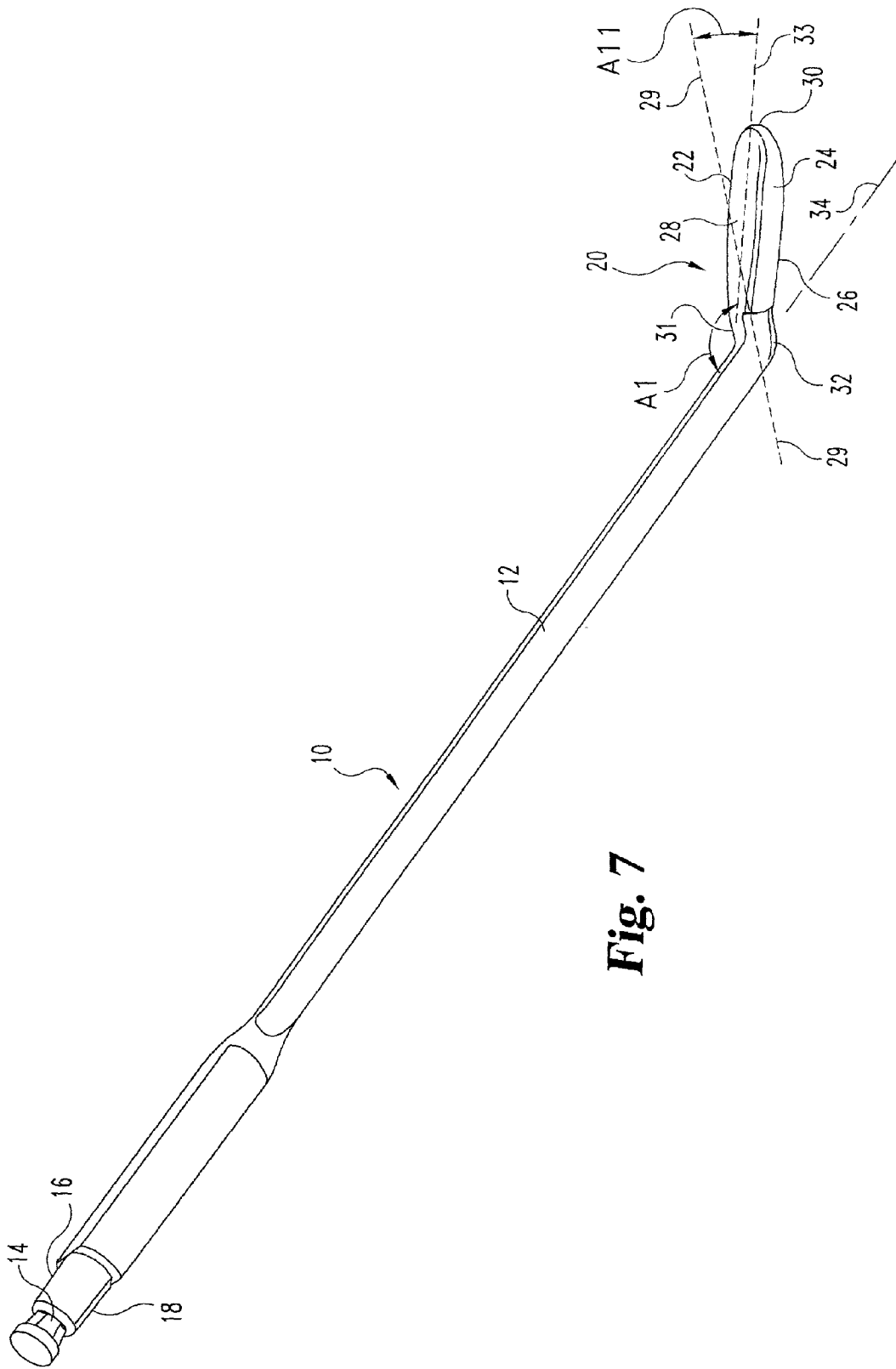
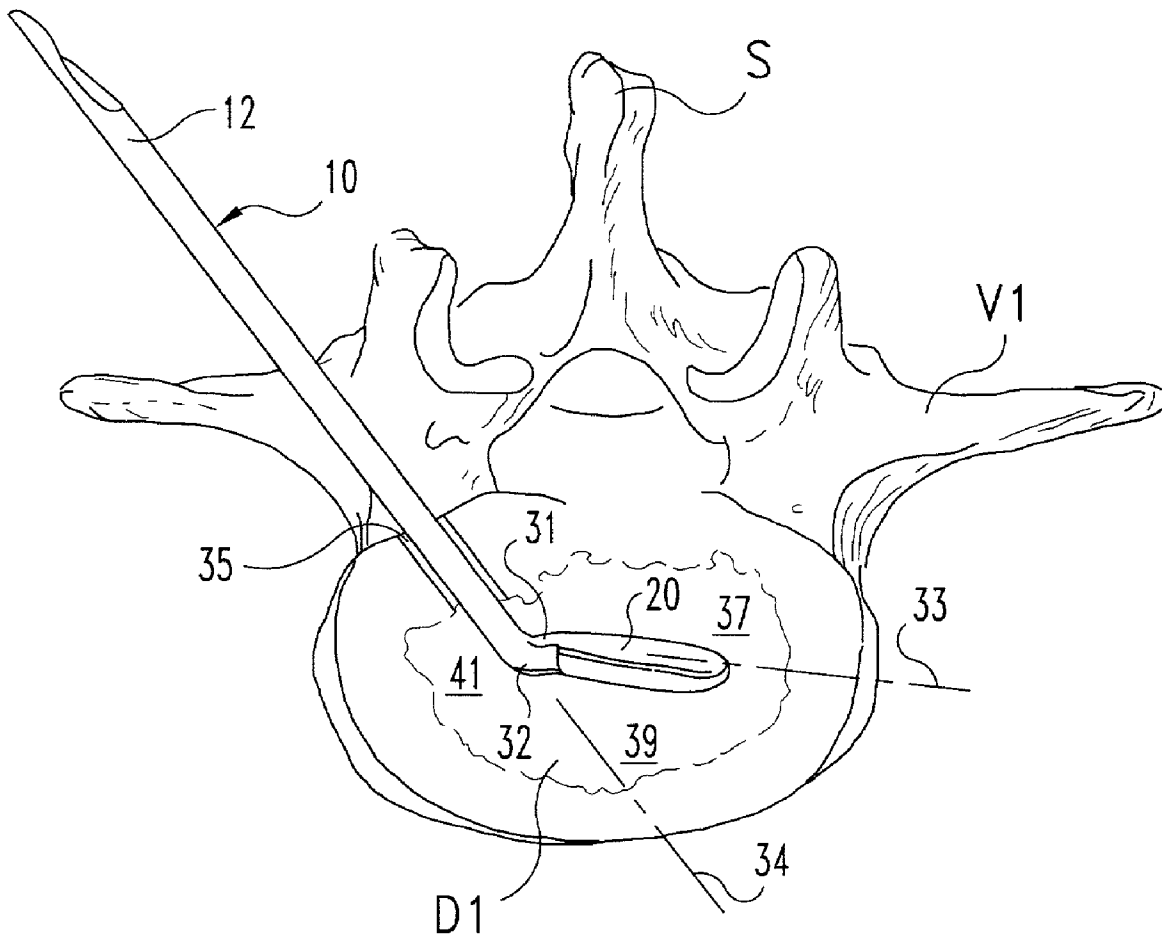


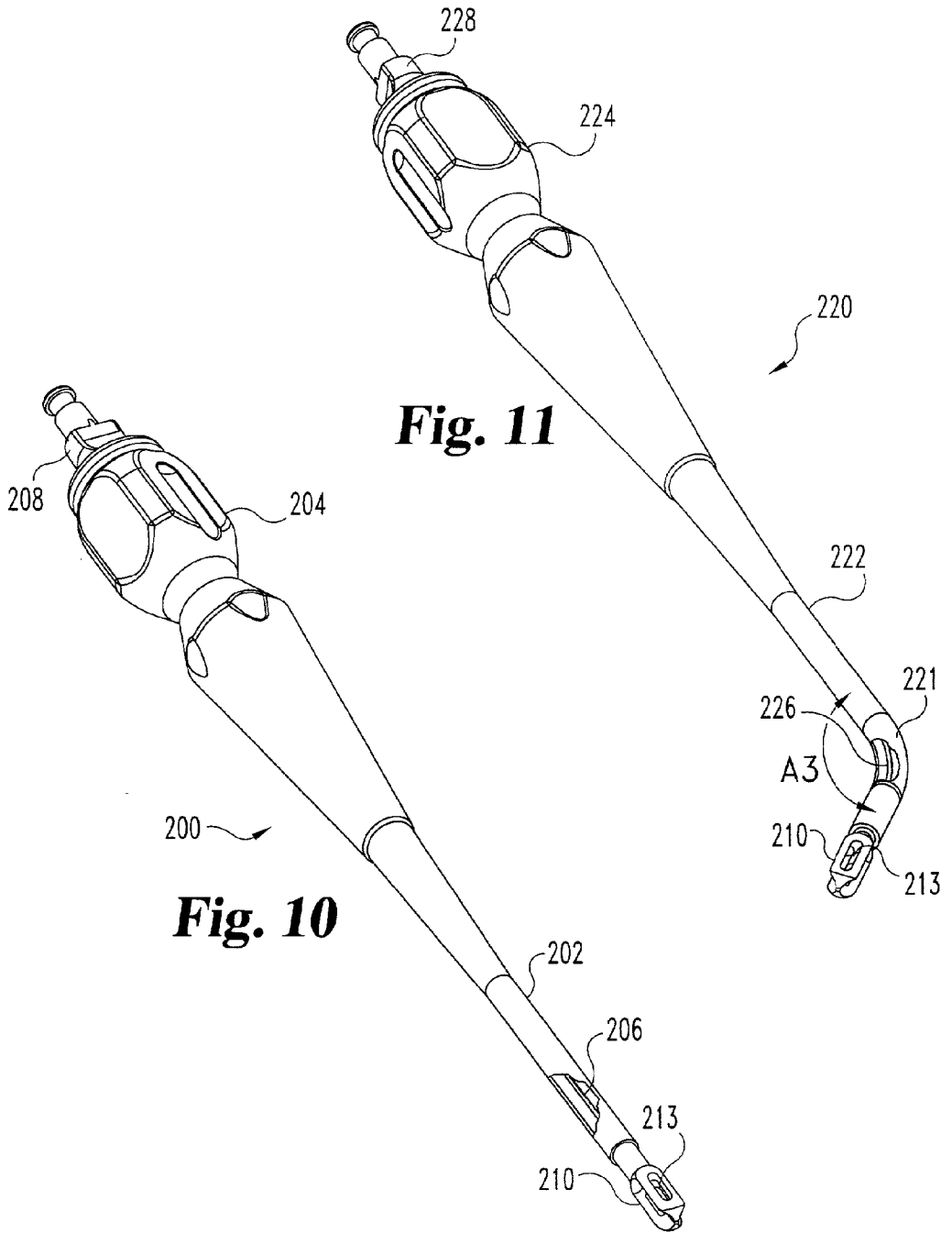
Fig. 7





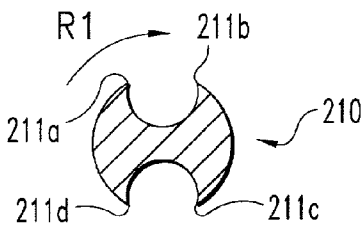


**Fig. 9**

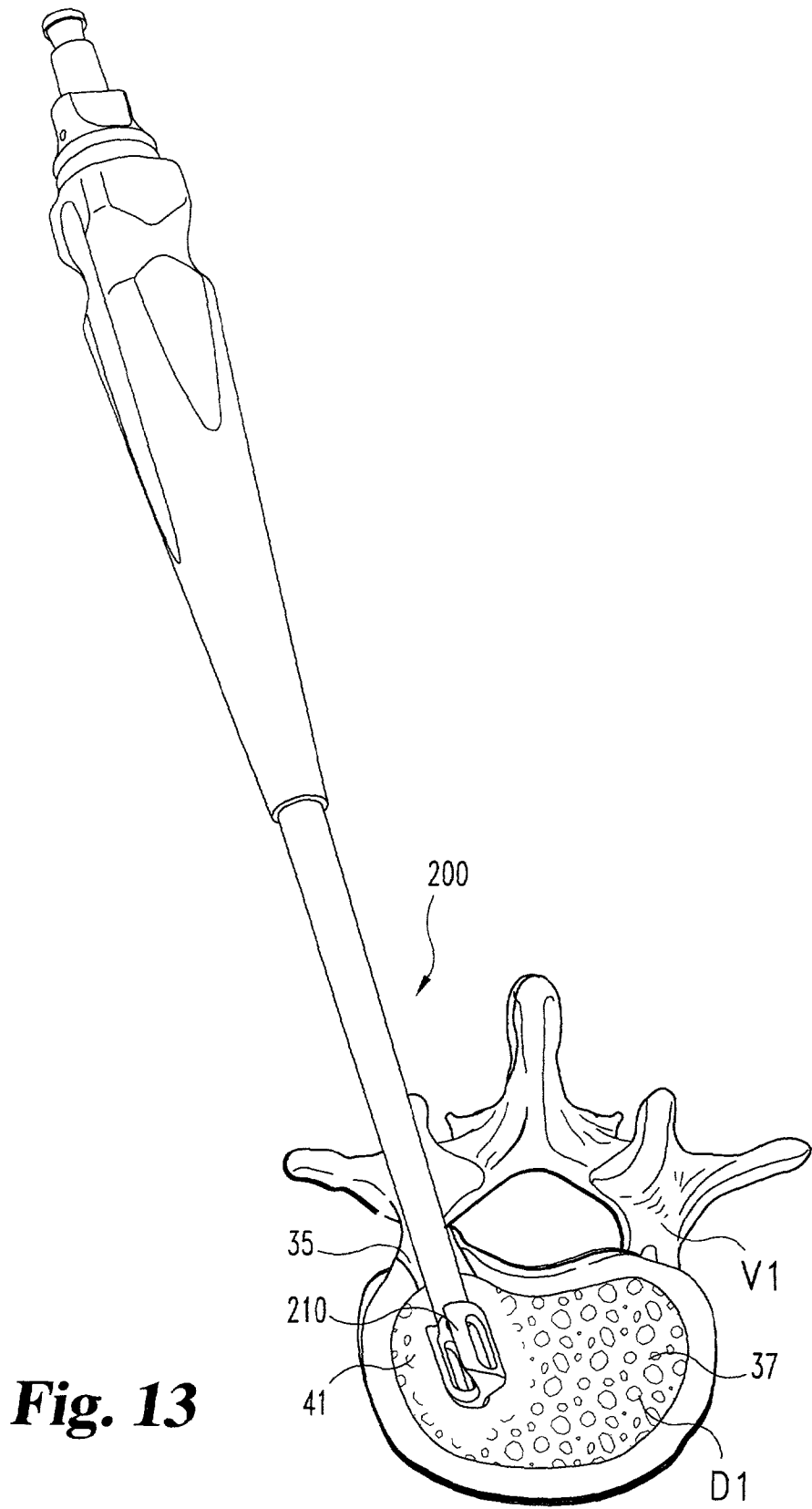


**Fig. 11**

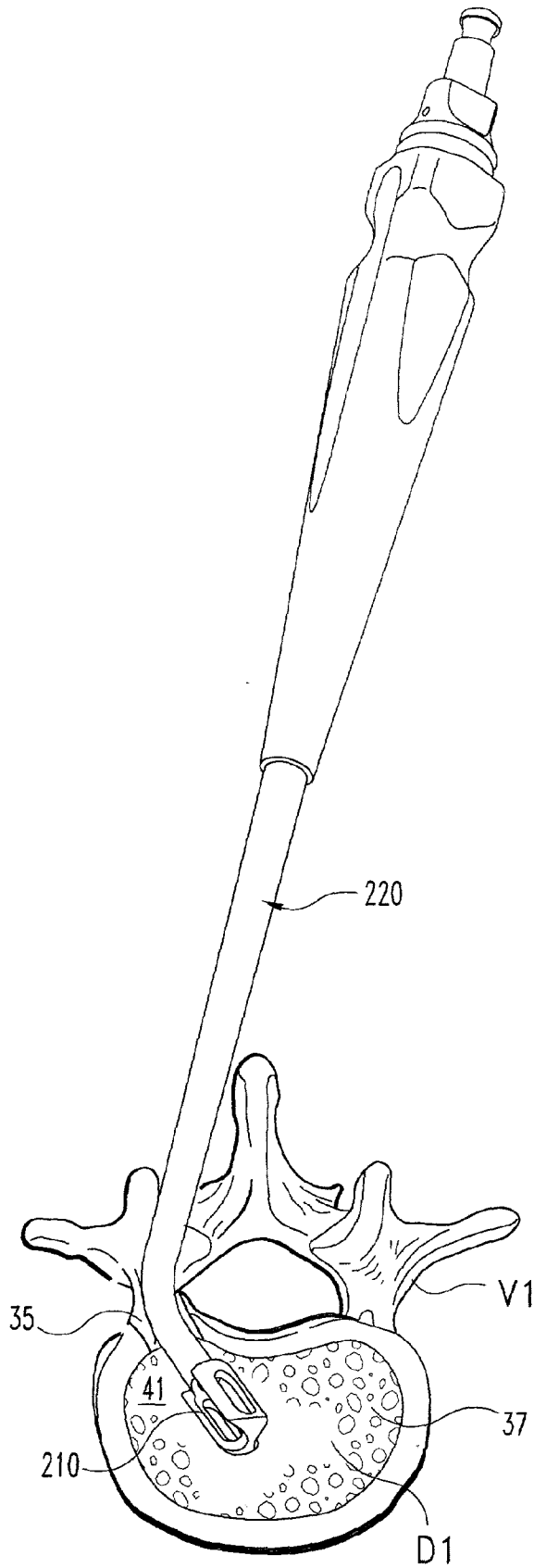
**Fig. 10**



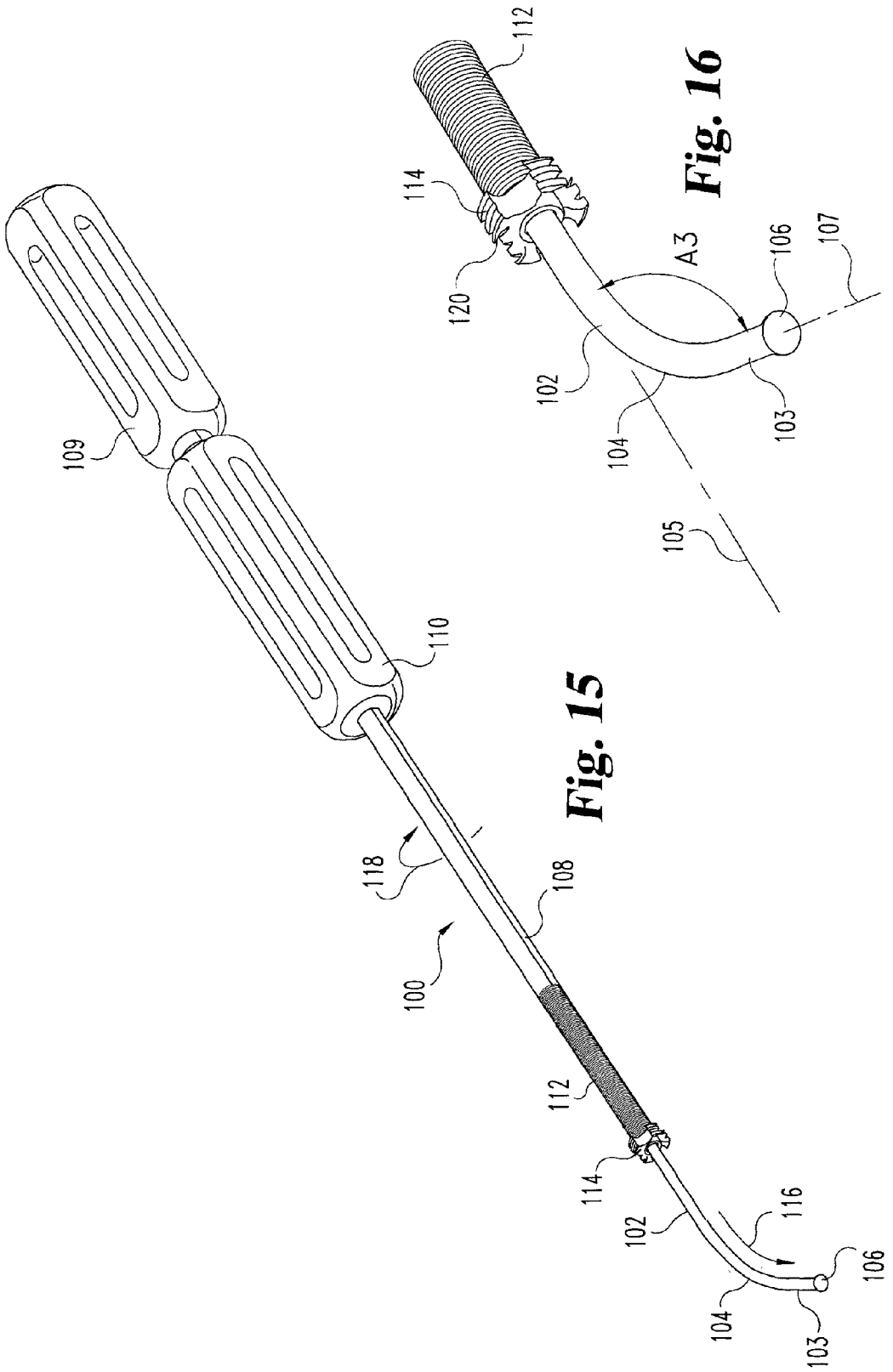
**Fig. 12**

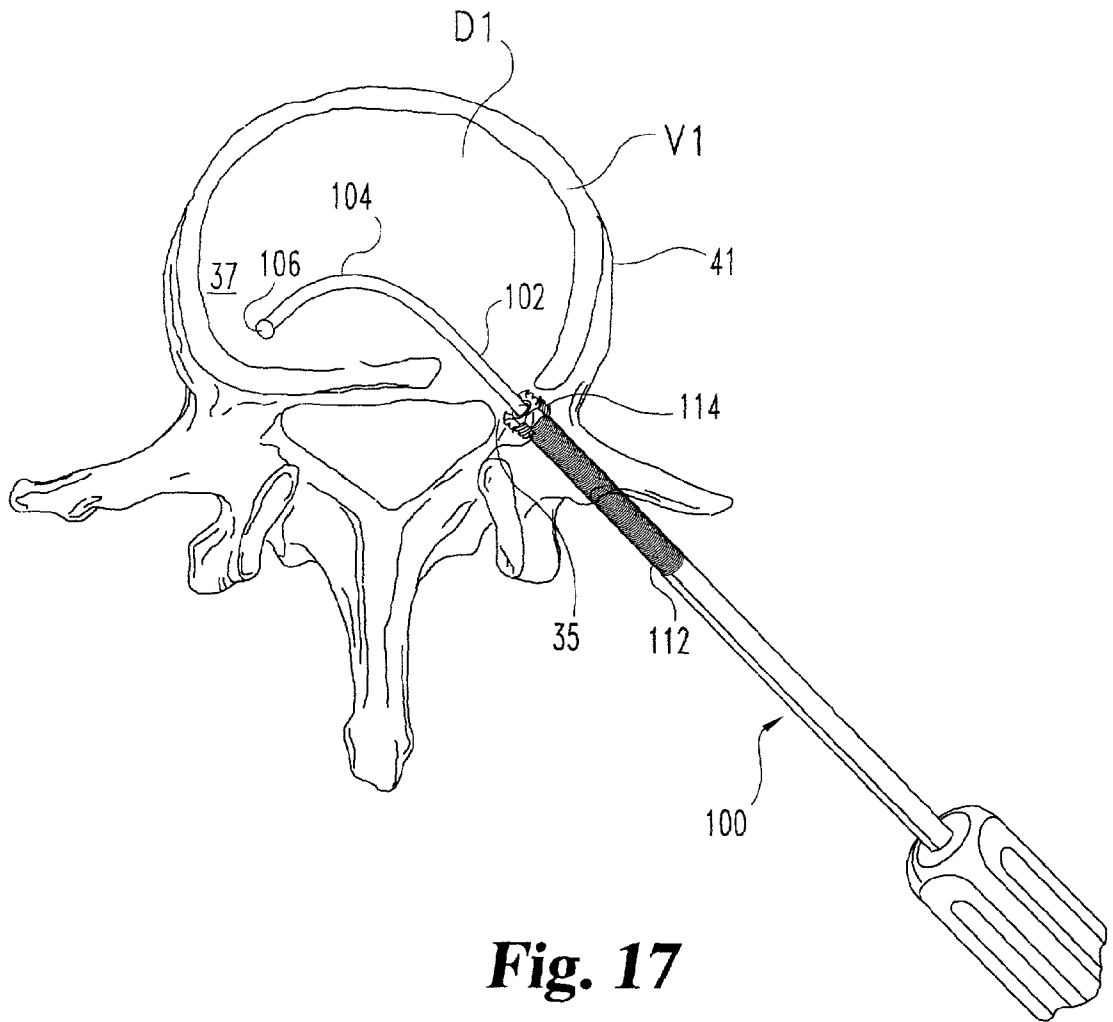


**Fig. 13**

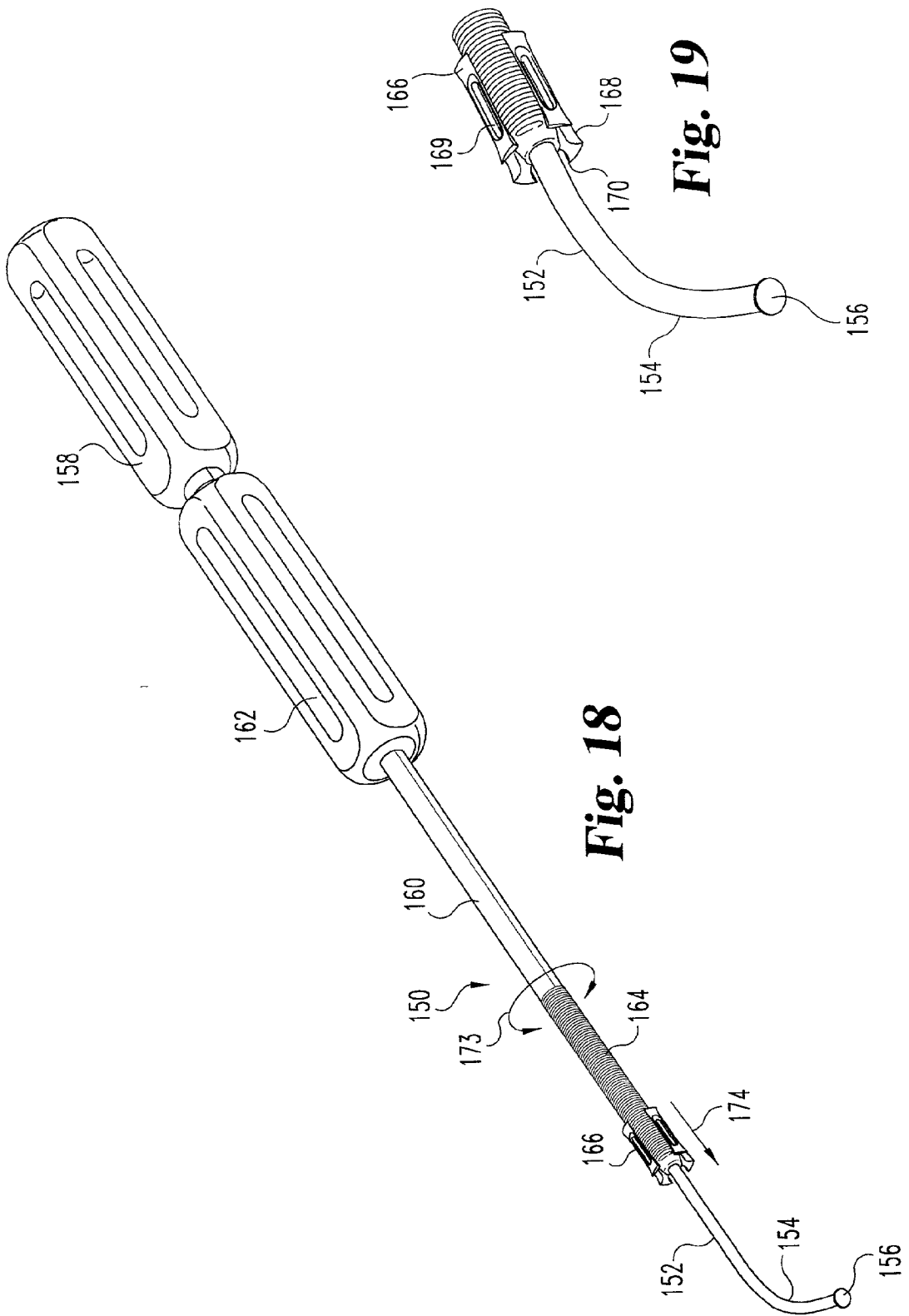


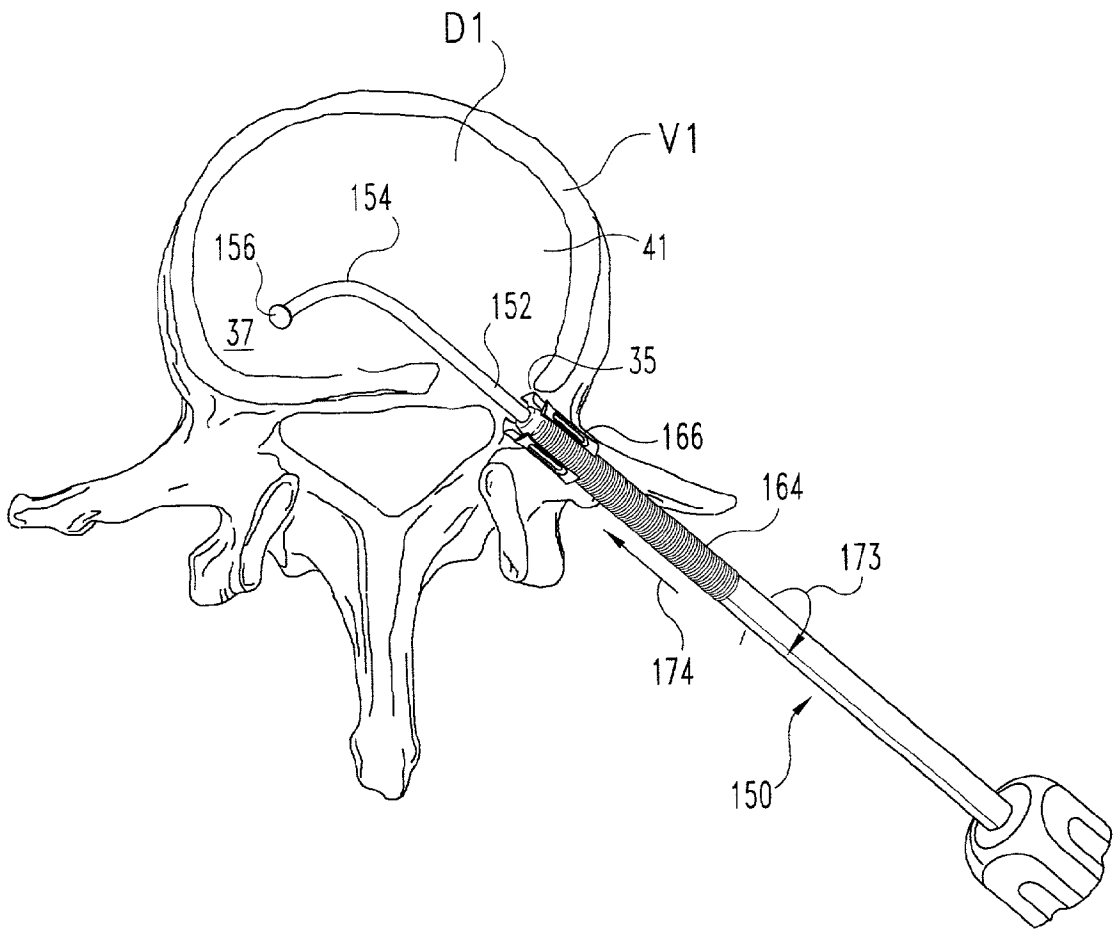
**Fig. 14**





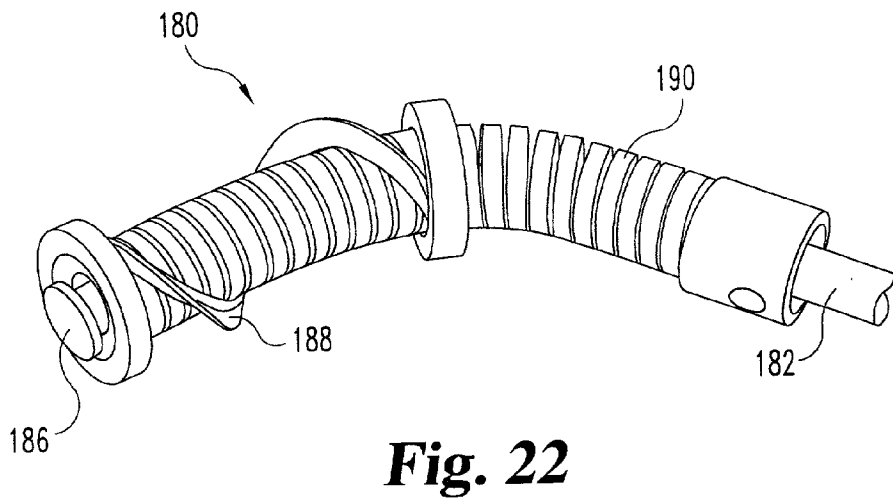
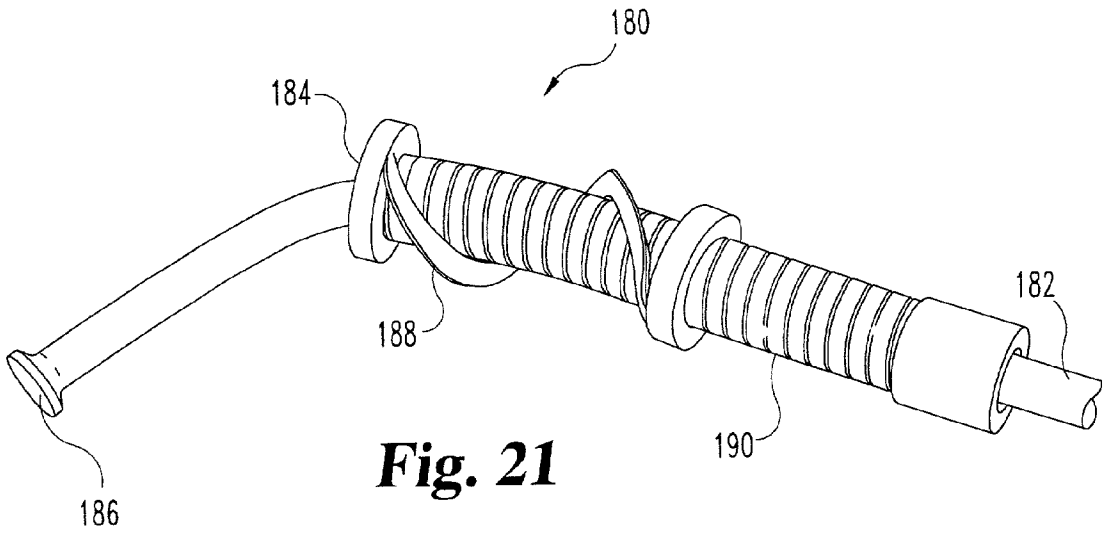
**Fig. 17**

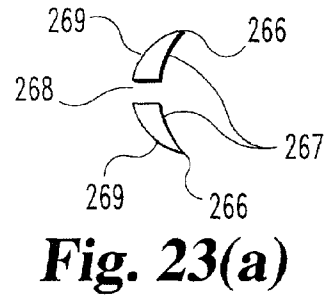
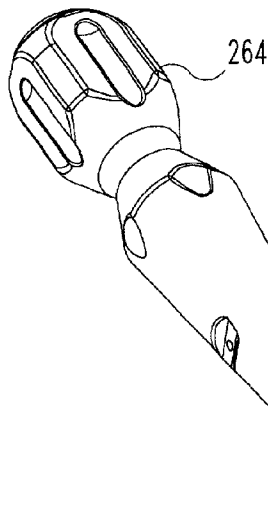




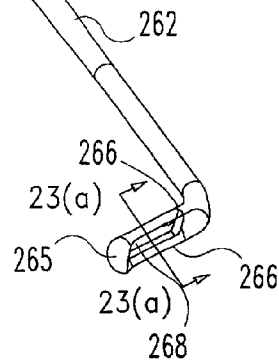
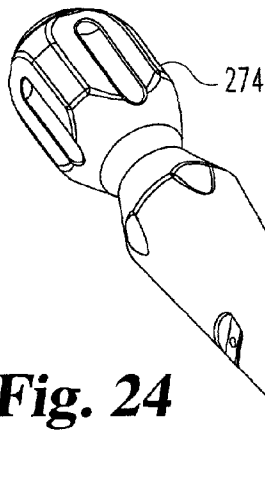
**Fig. 20**



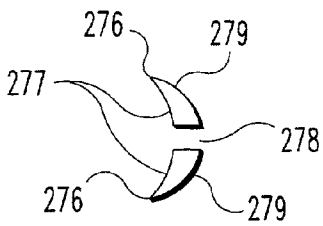




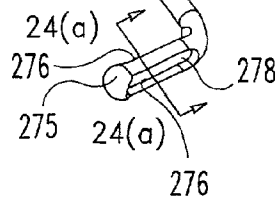
**Fig. 23**

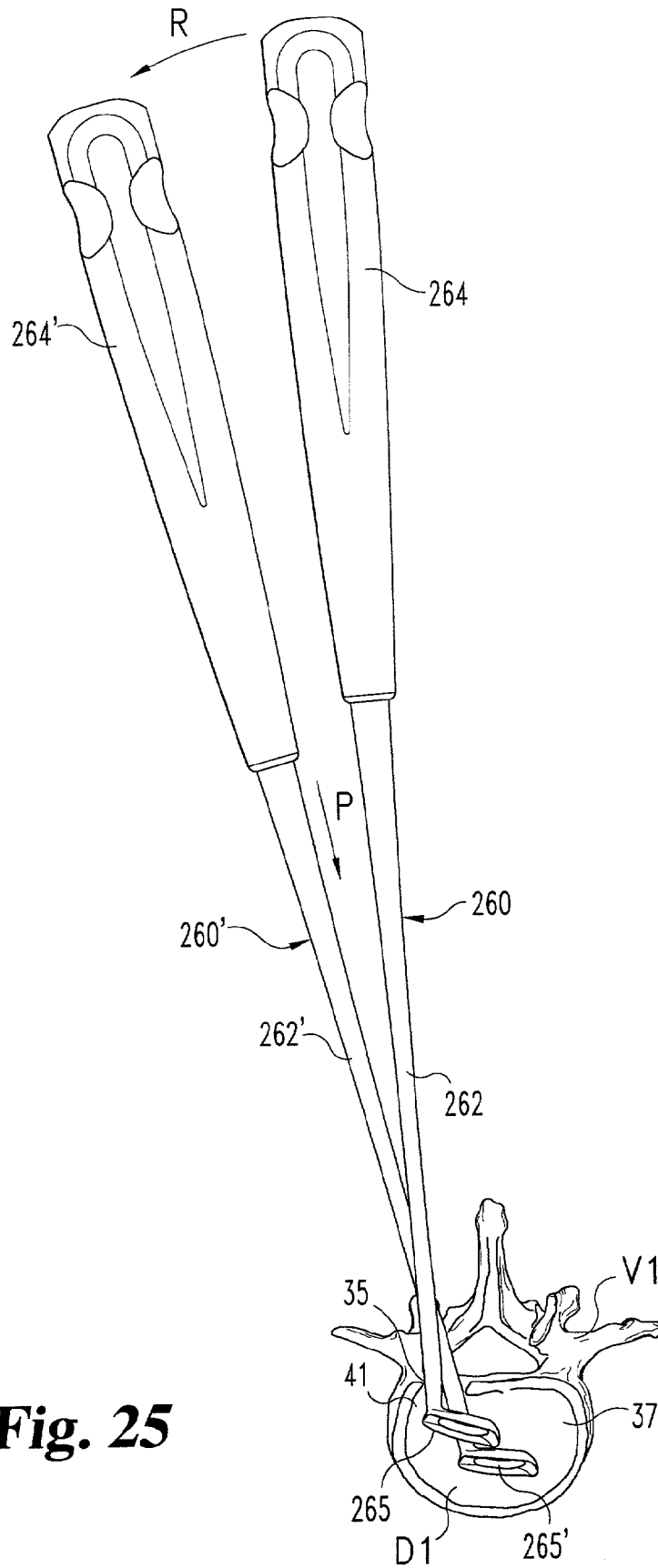


**Fig. 24**

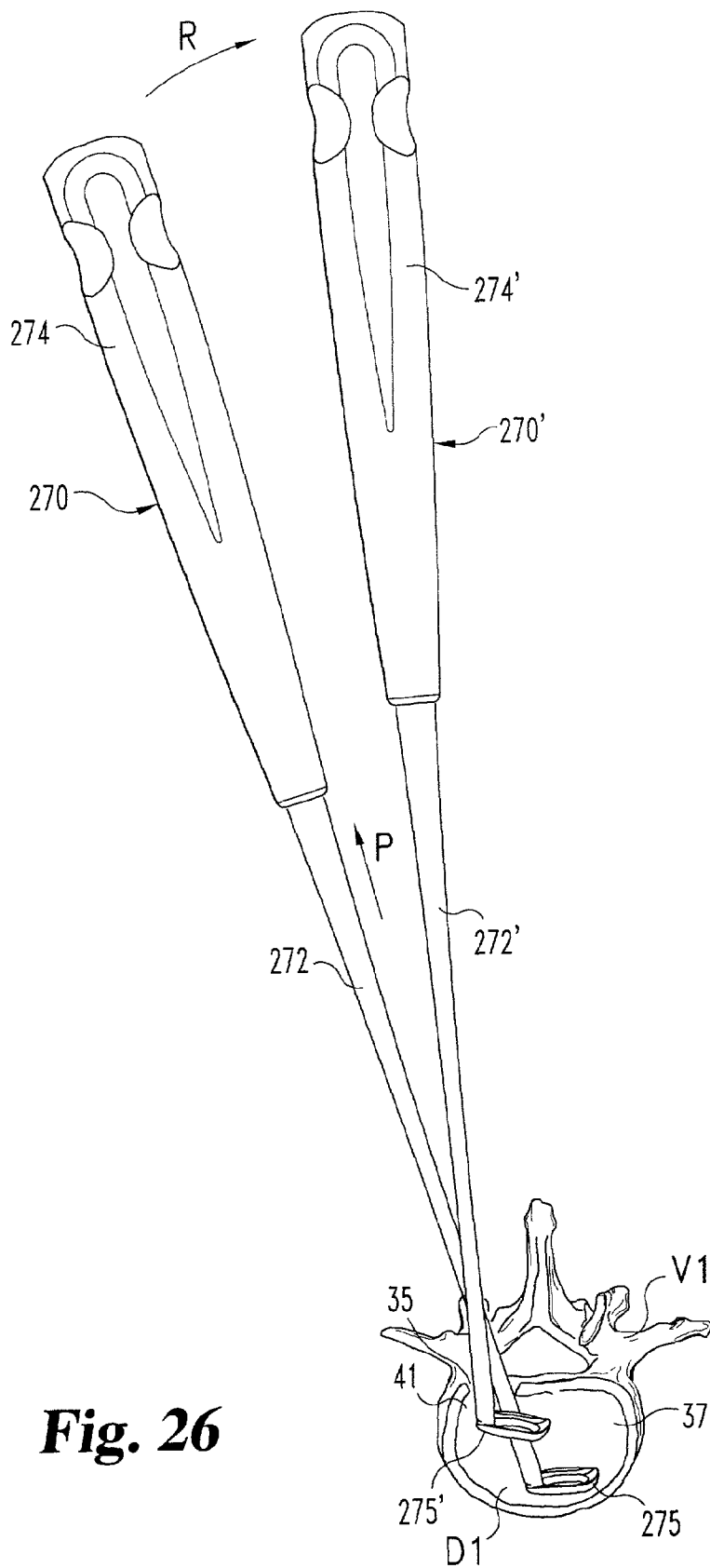


**Fig. 24(a)**

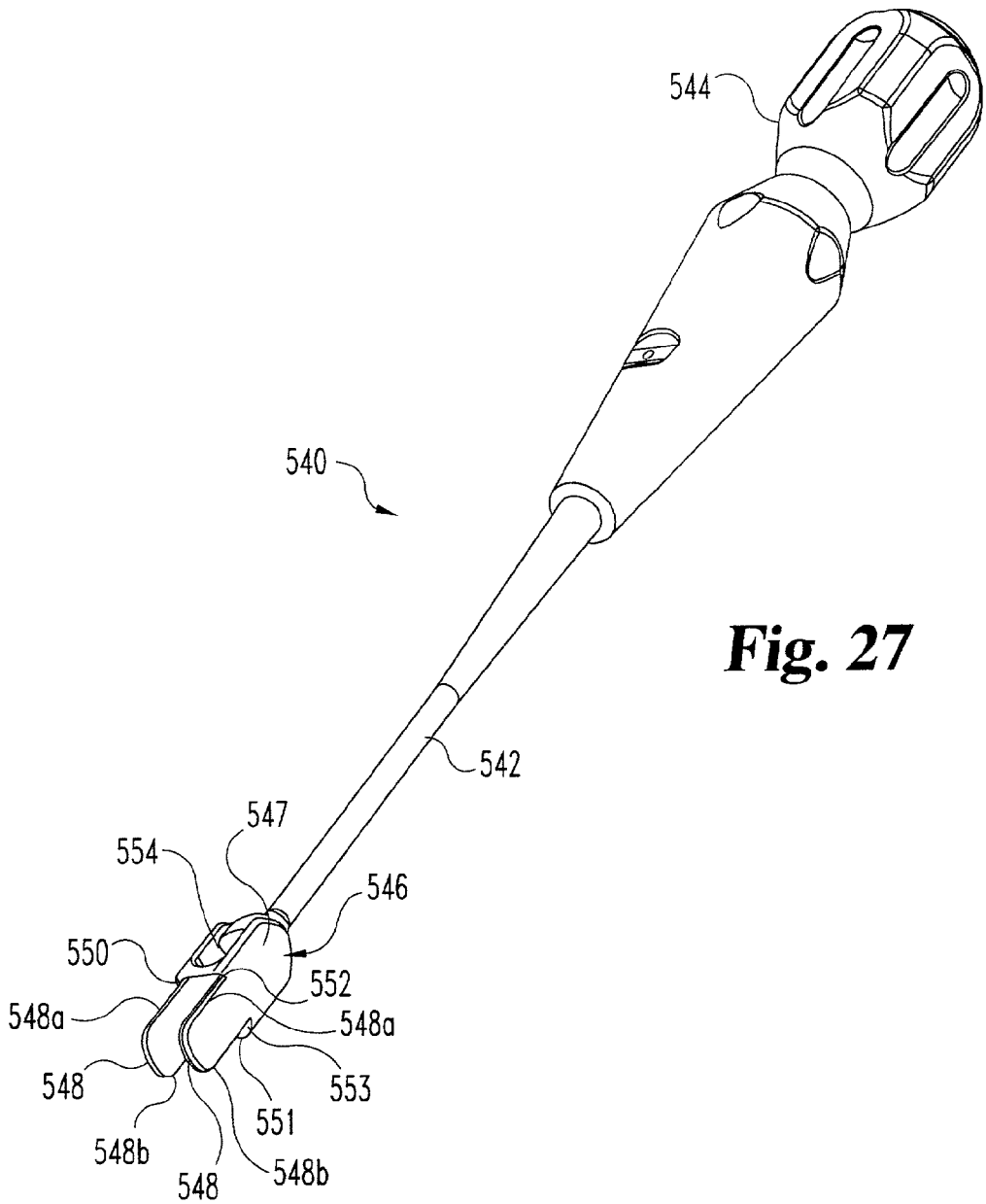




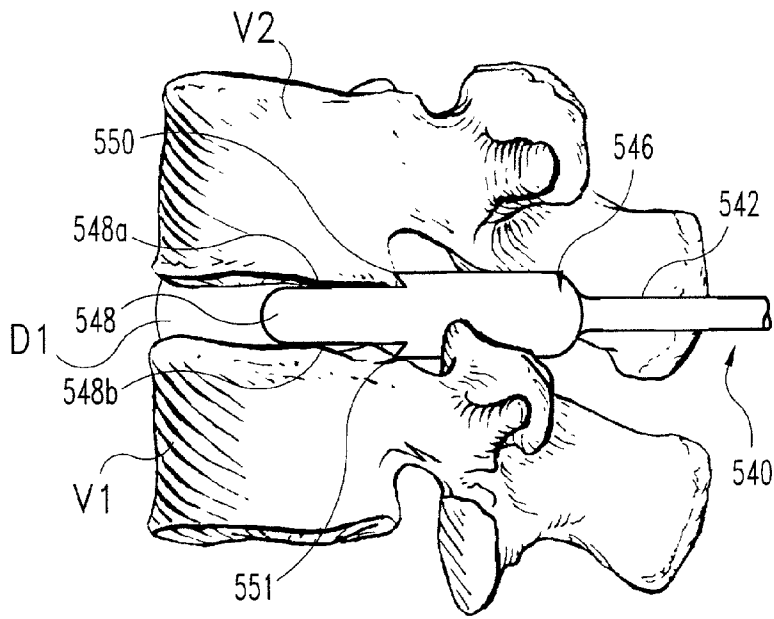
**Fig. 25**



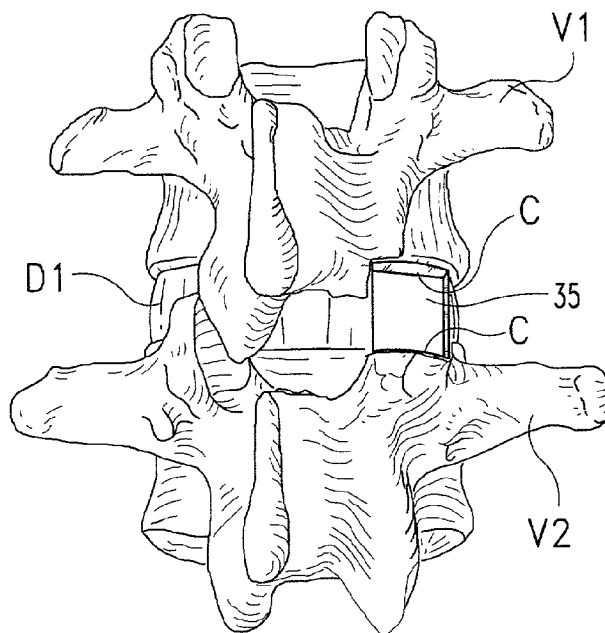
**Fig. 26**



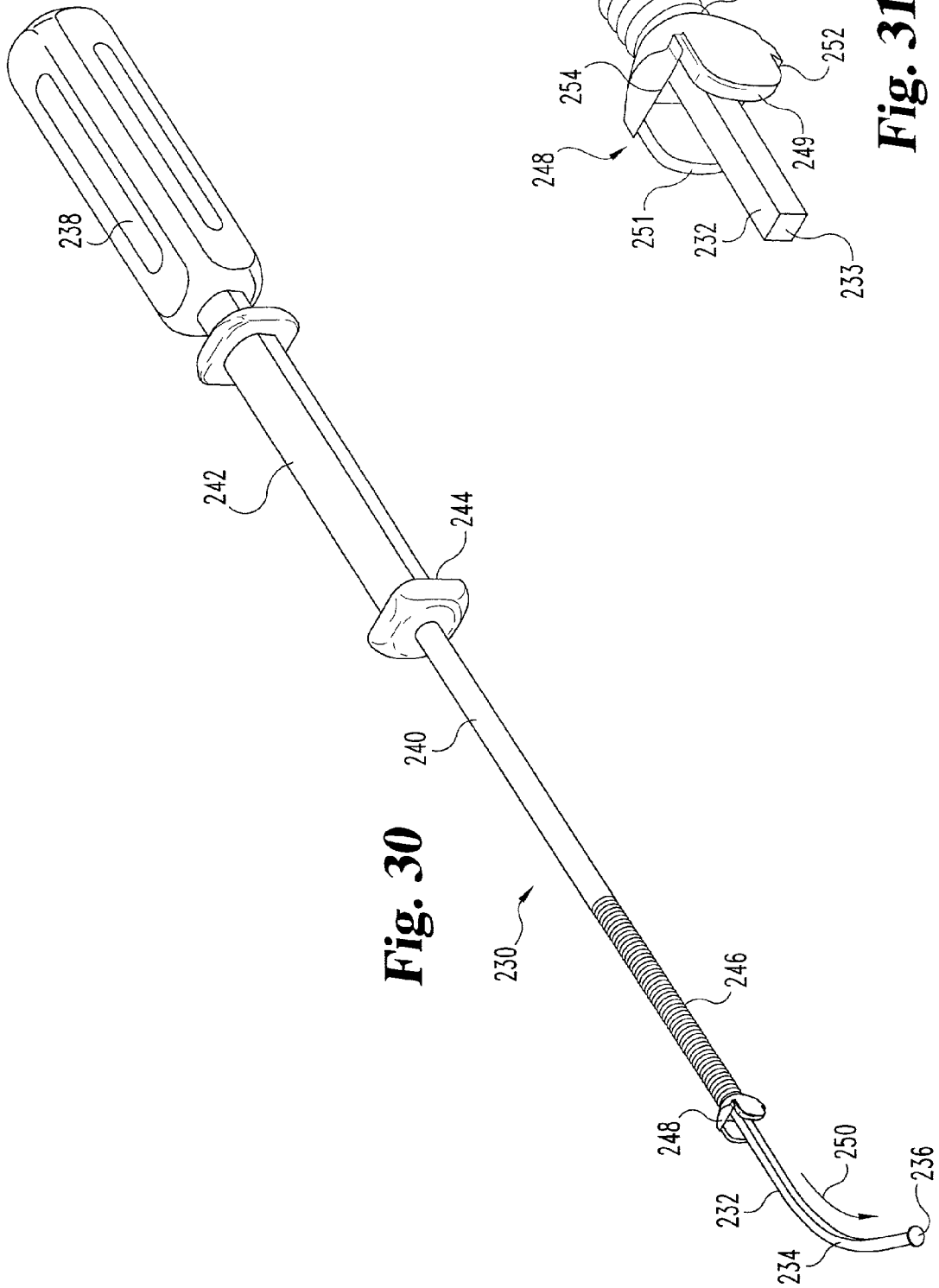
**Fig. 27**



**Fig. 28**

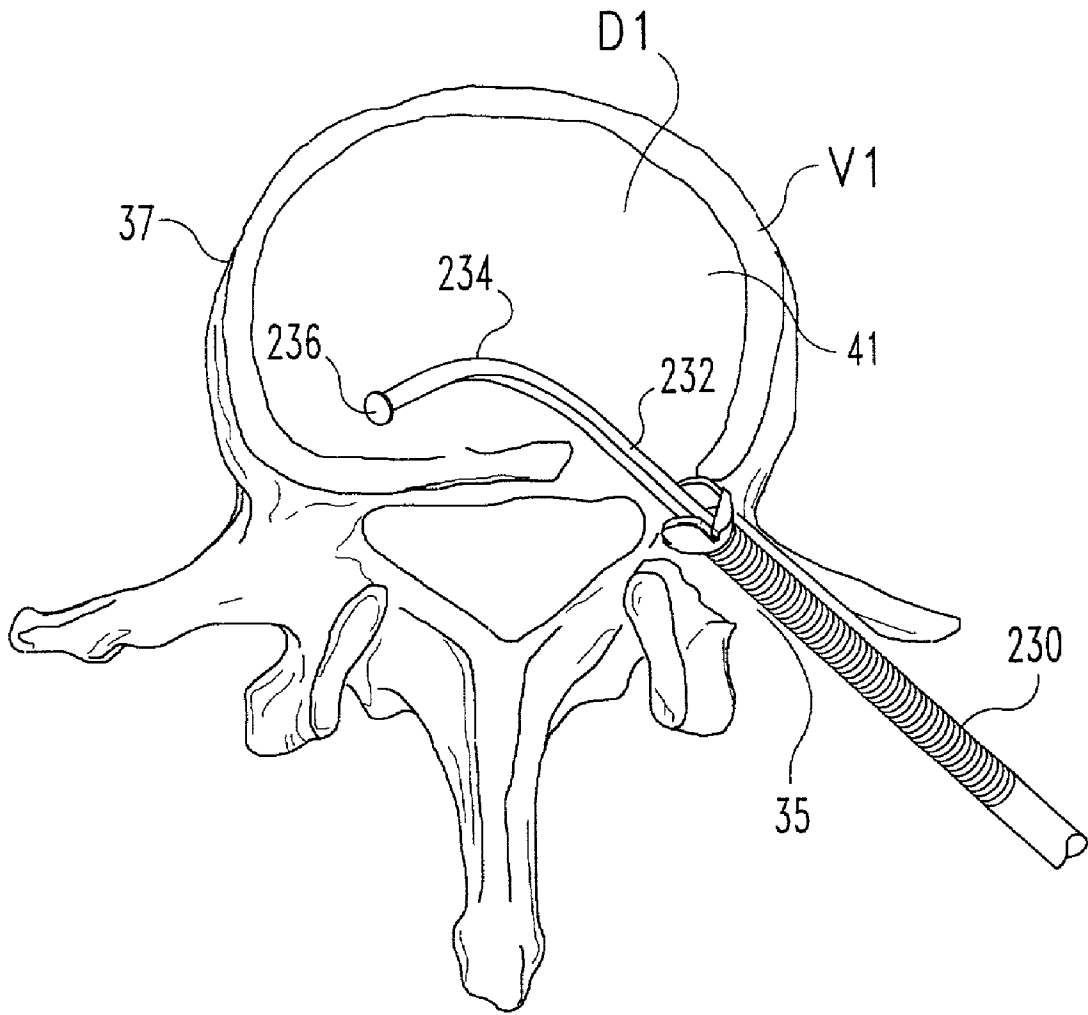


**Fig. 29**



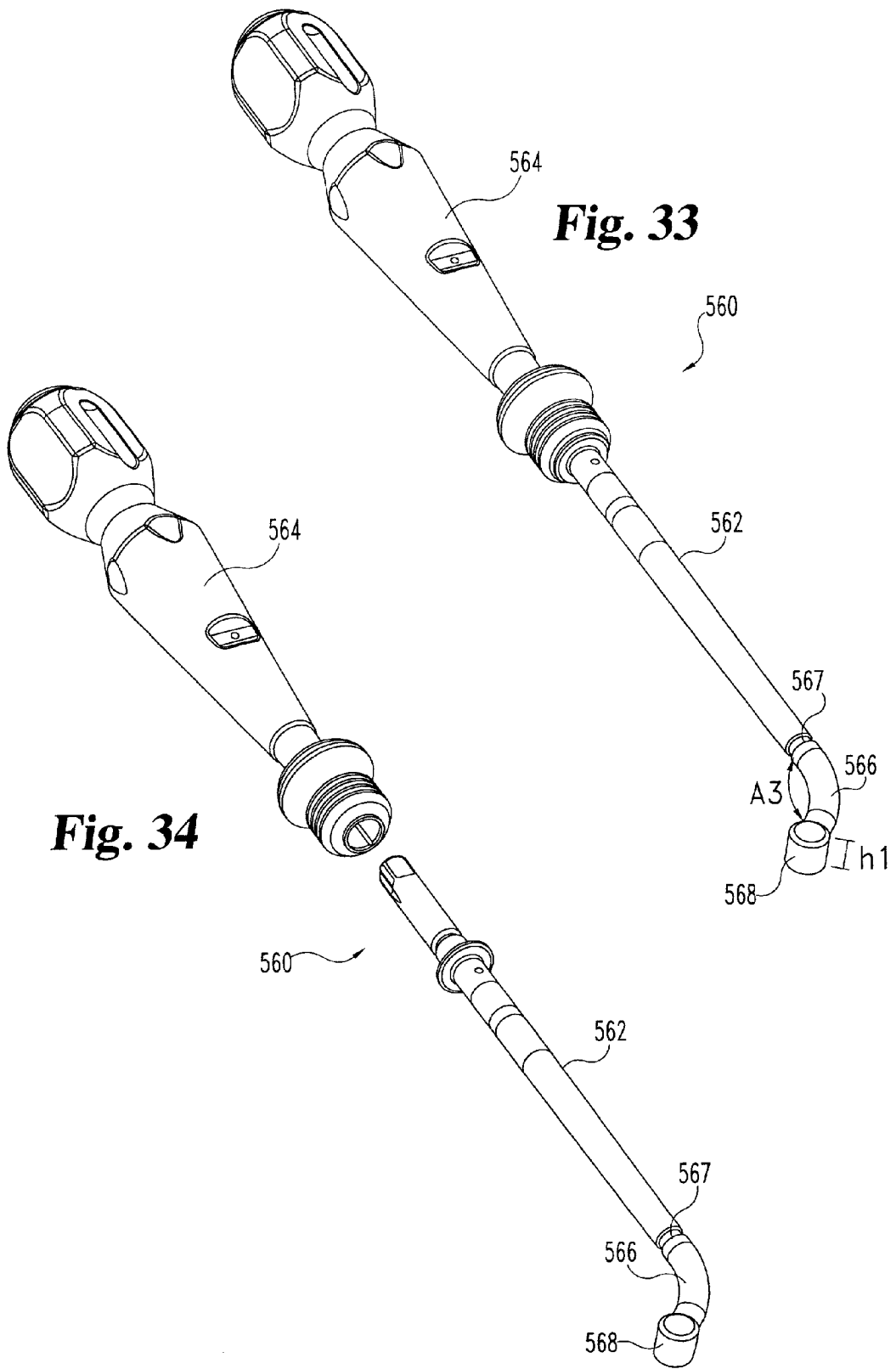
**Fig. 30**

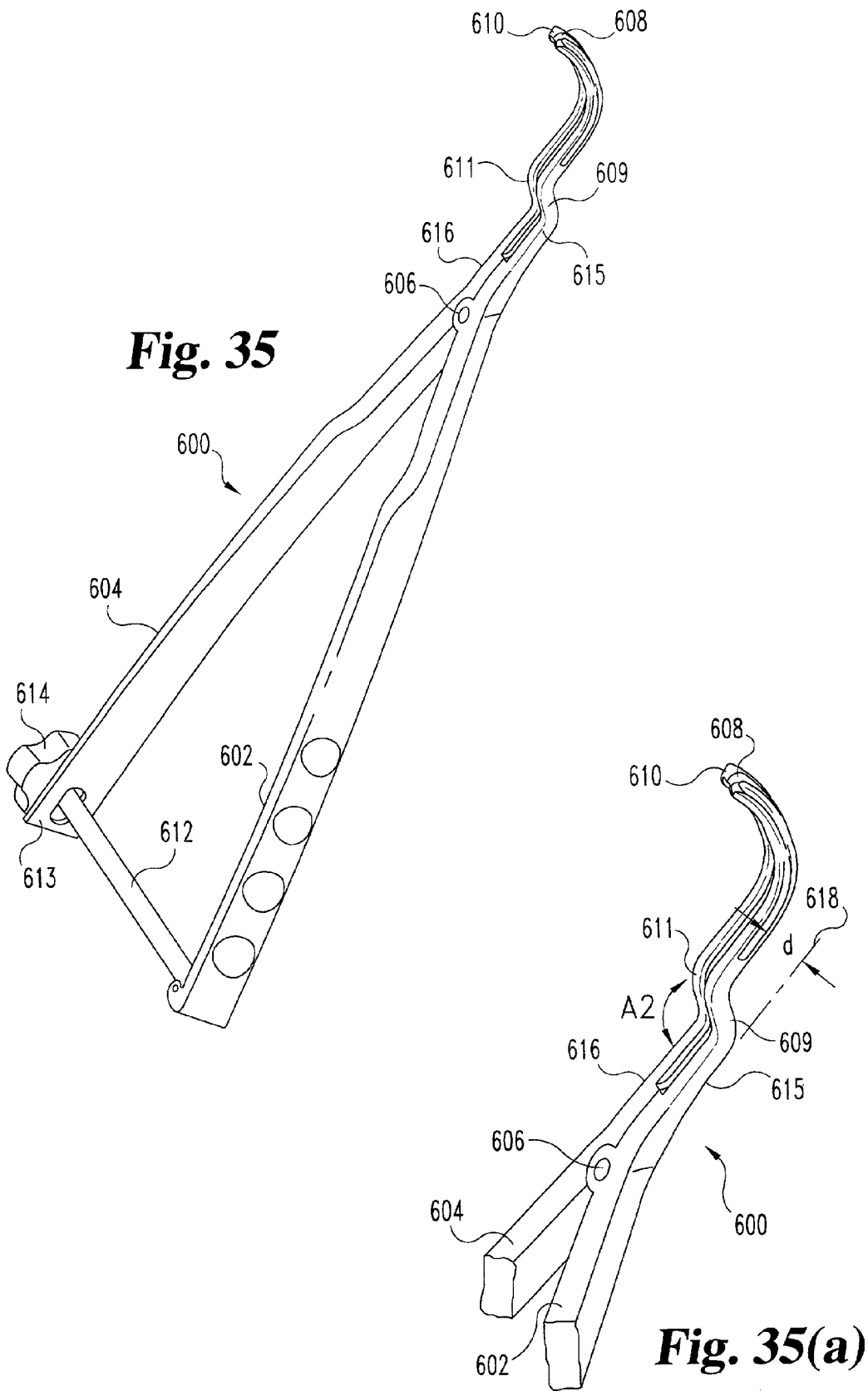
**Fig. 31**

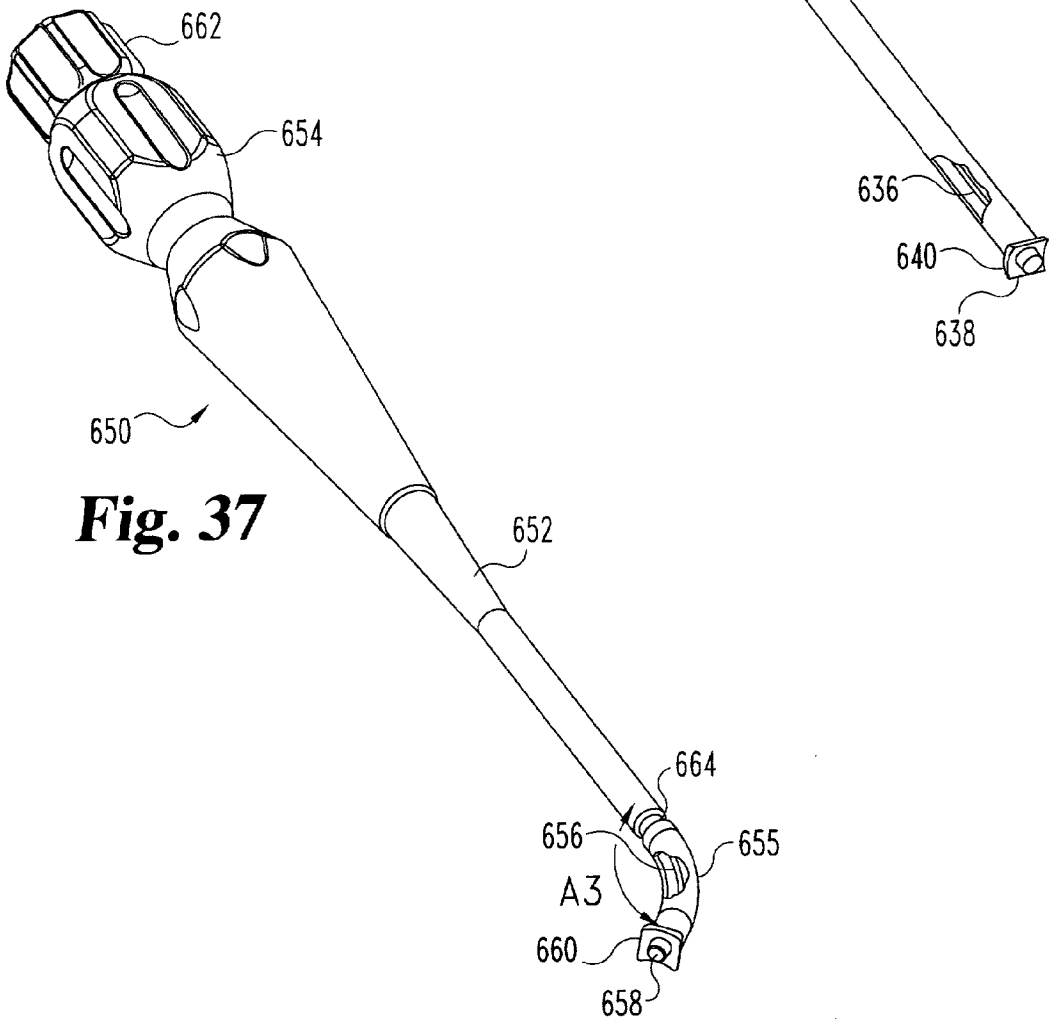
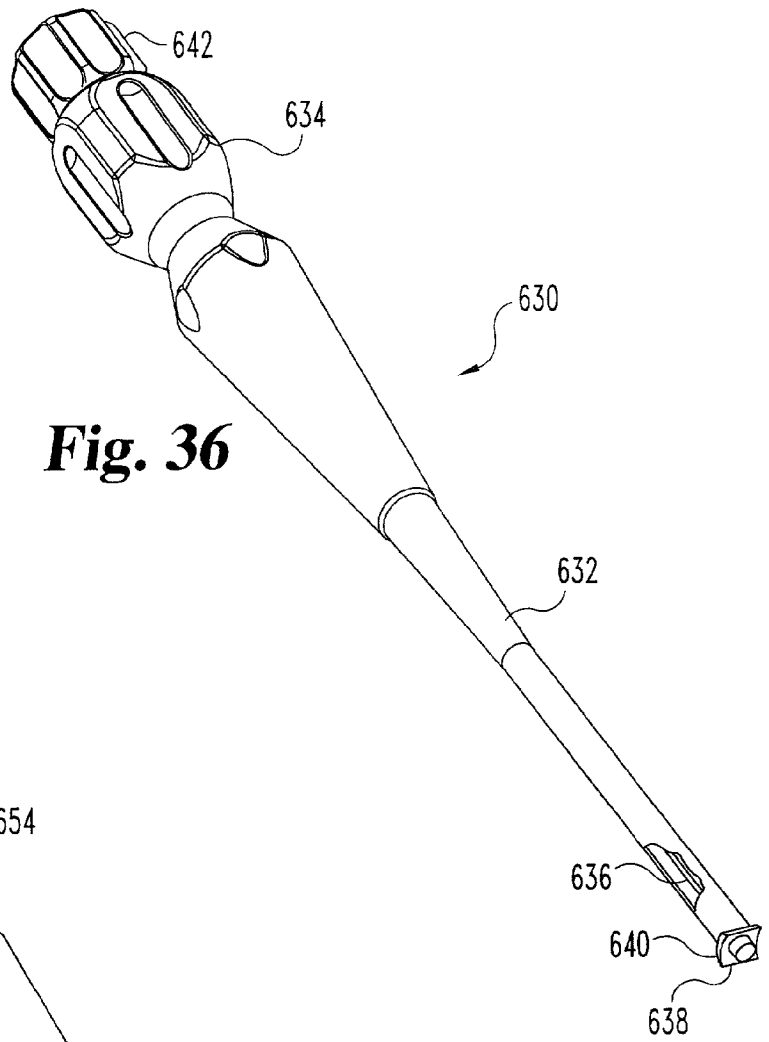


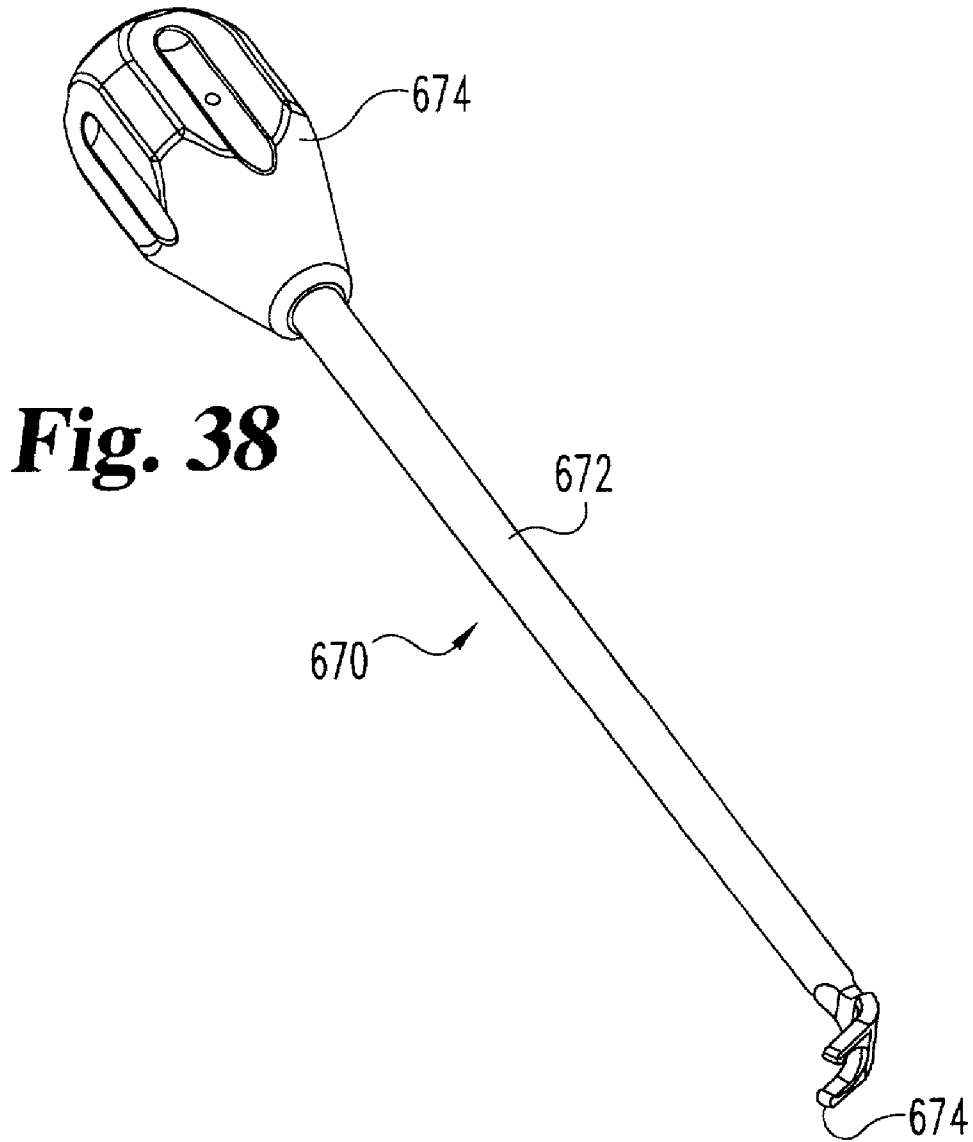
**Fig. 32**

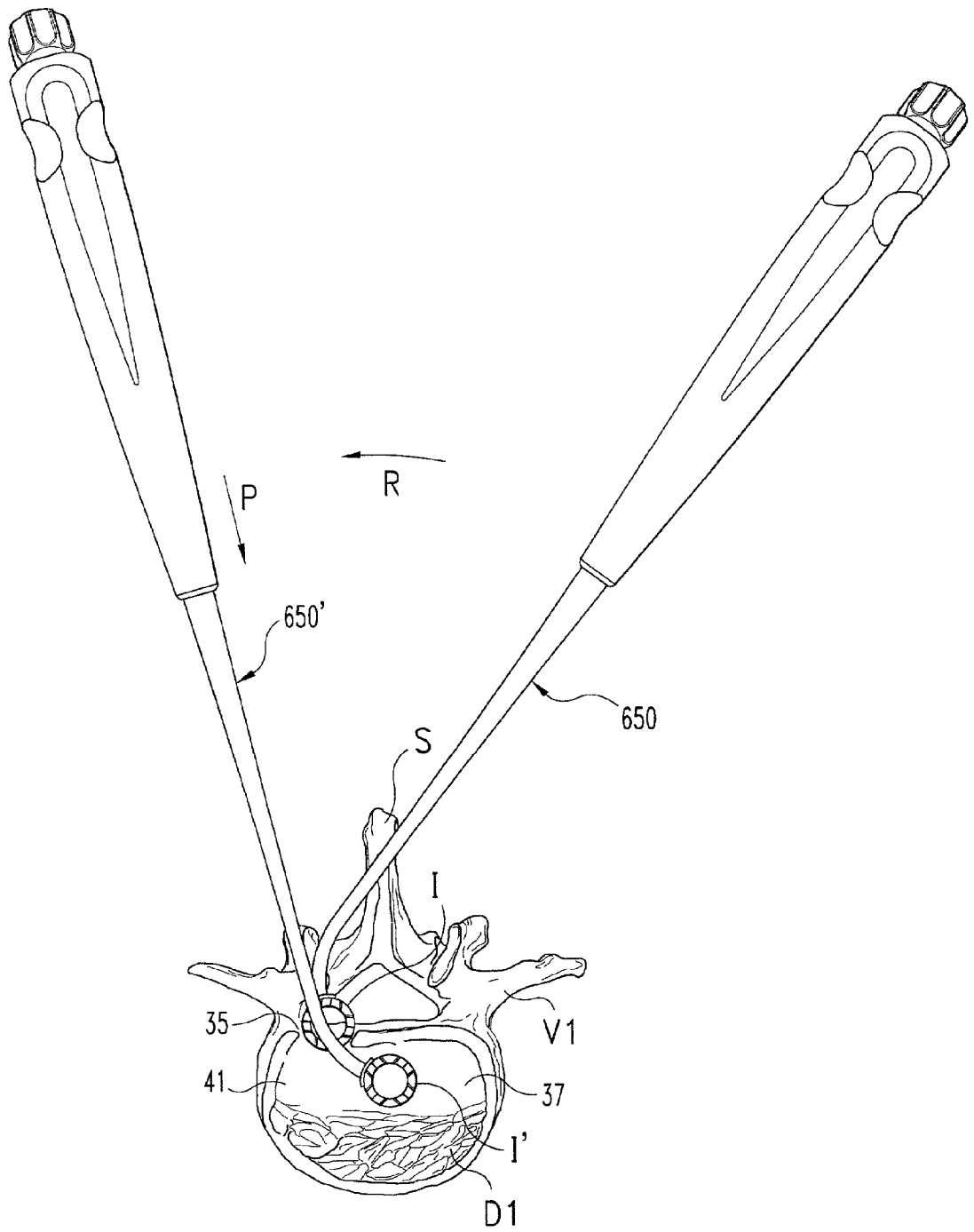




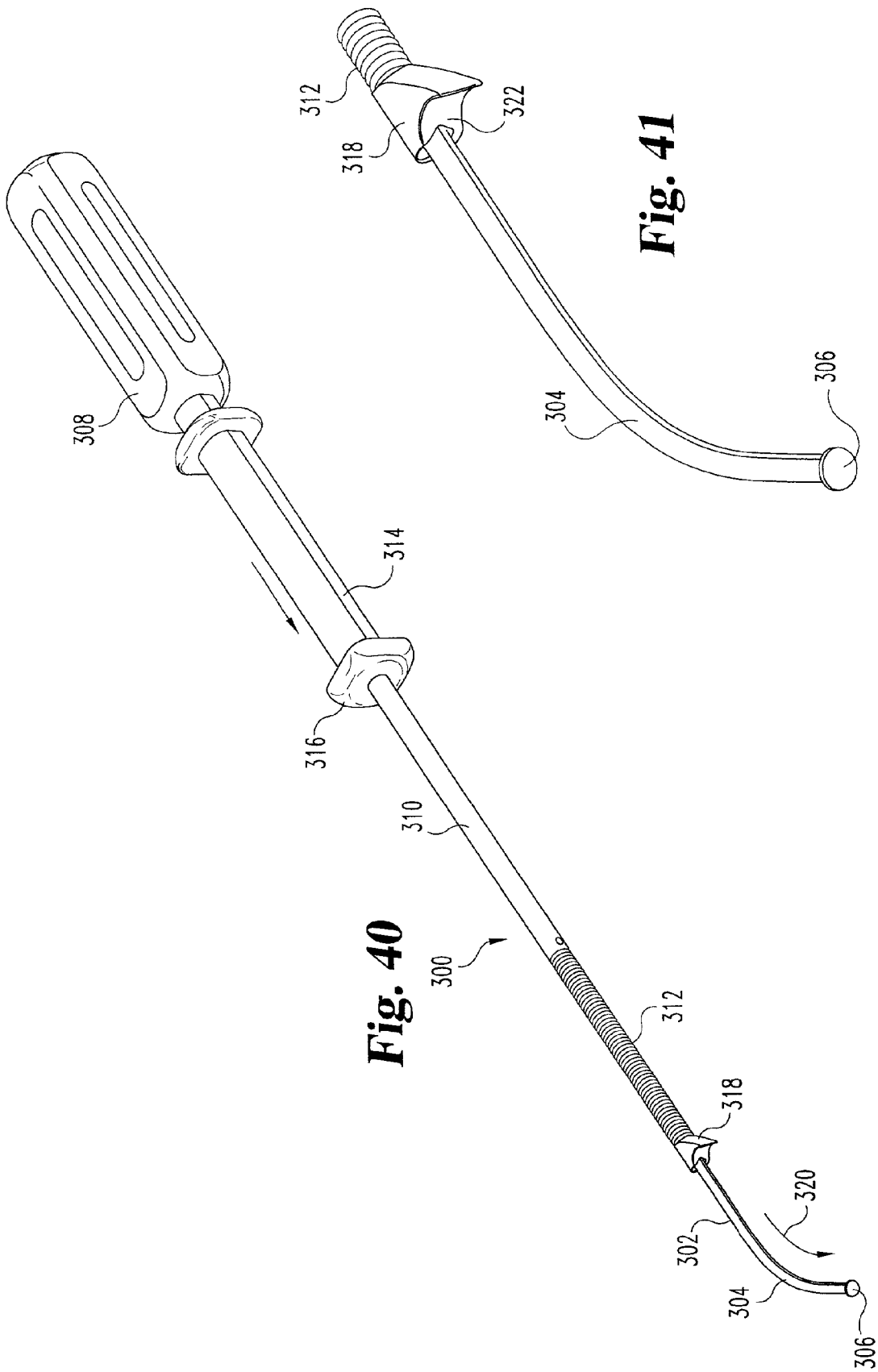


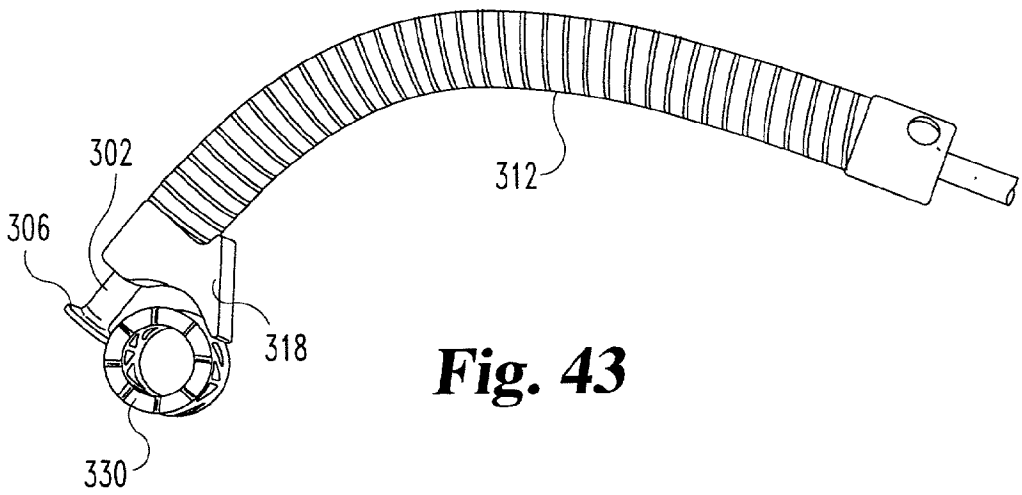
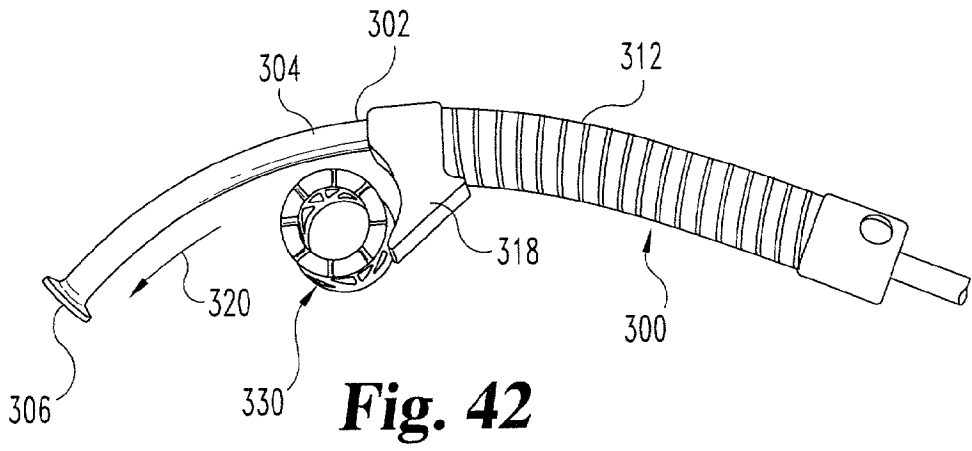


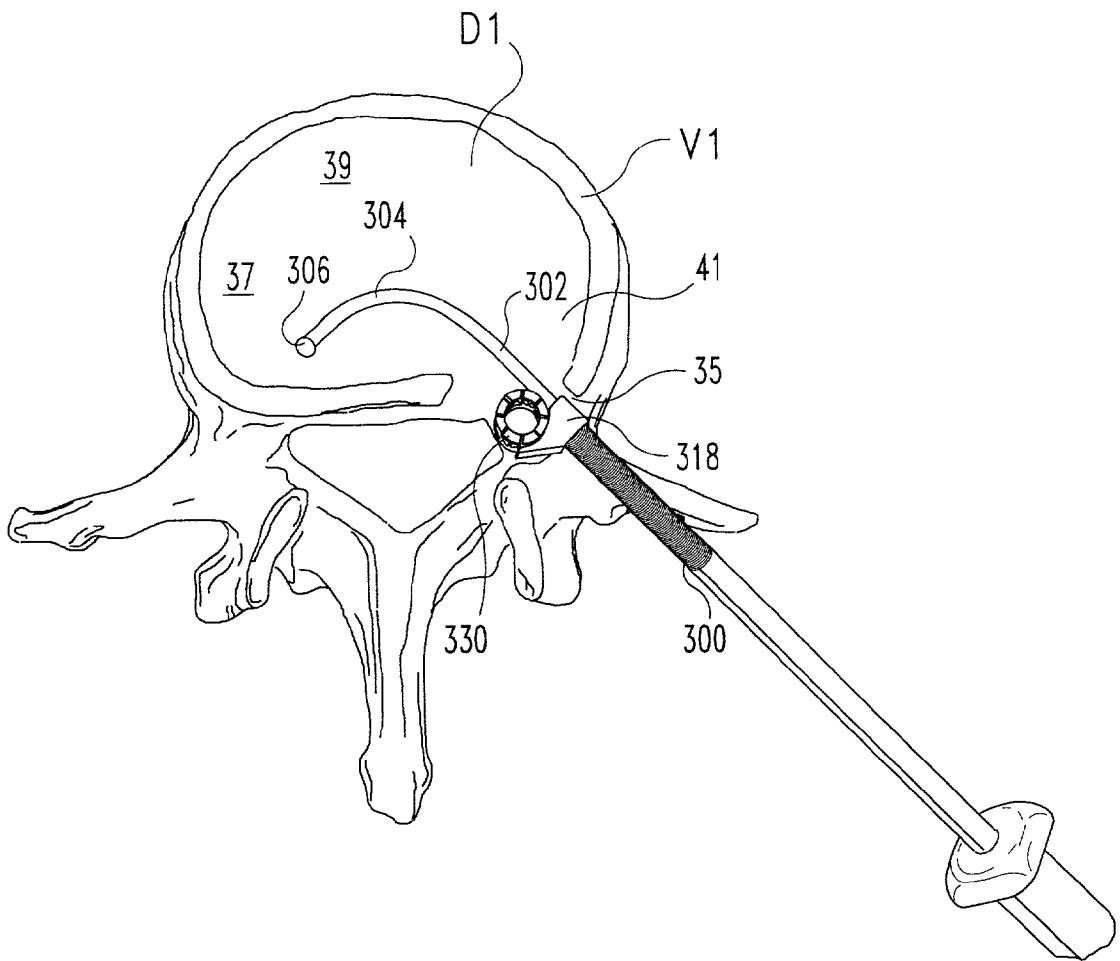




**Fig. 39**

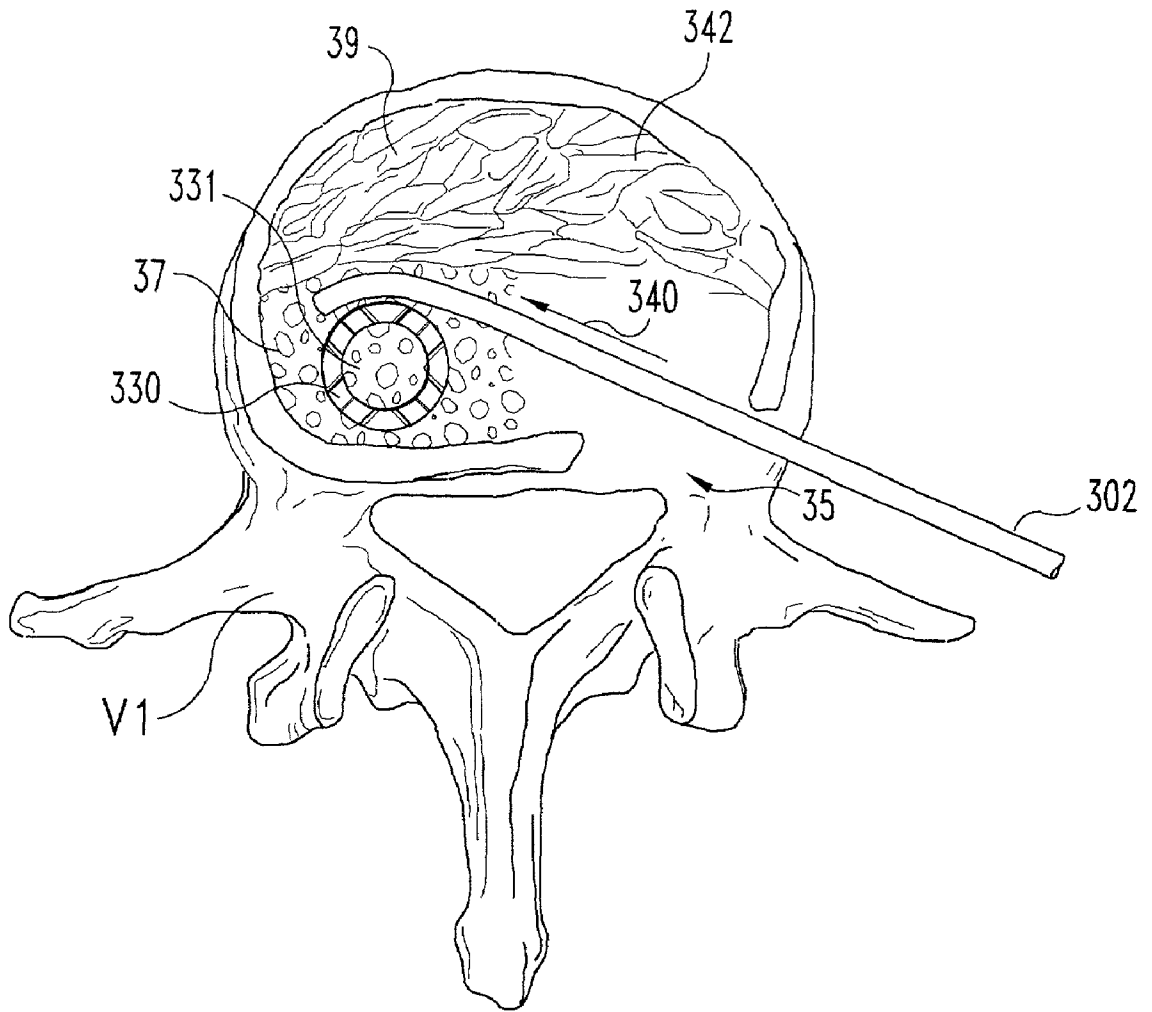




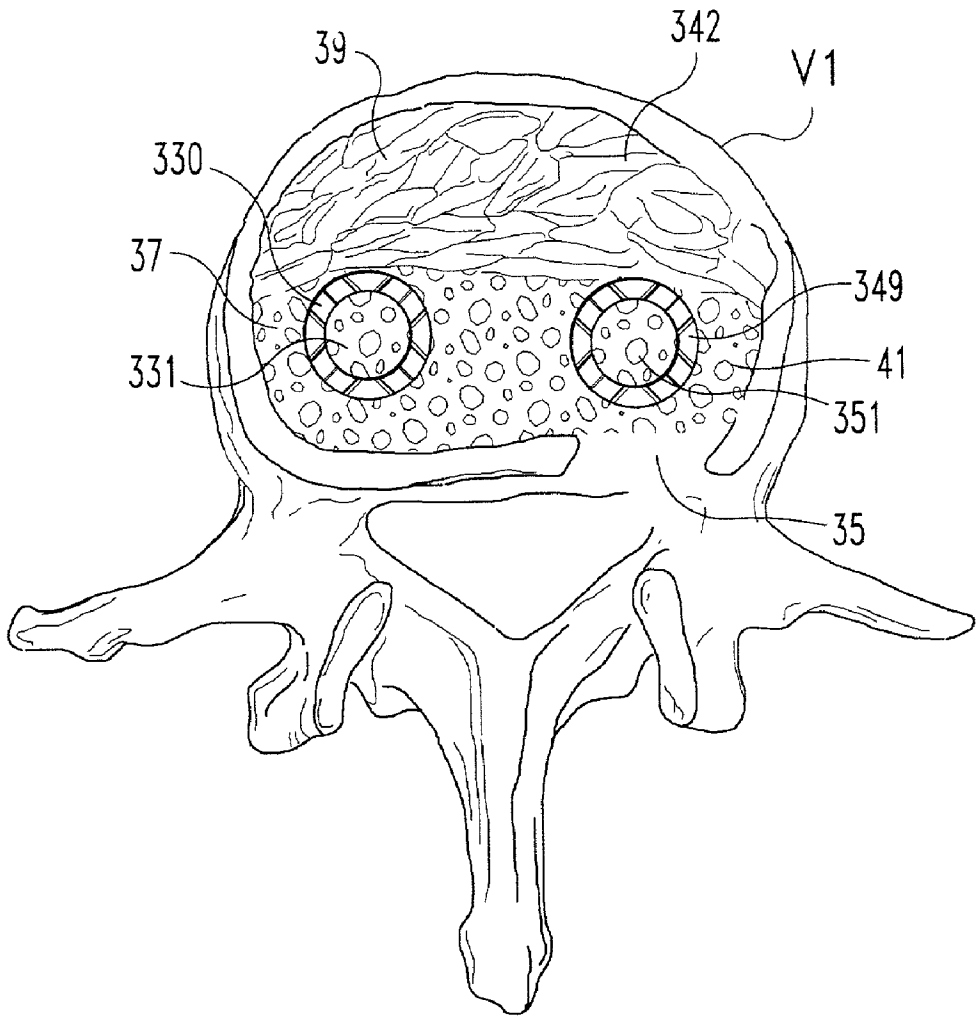


**Fig. 44**

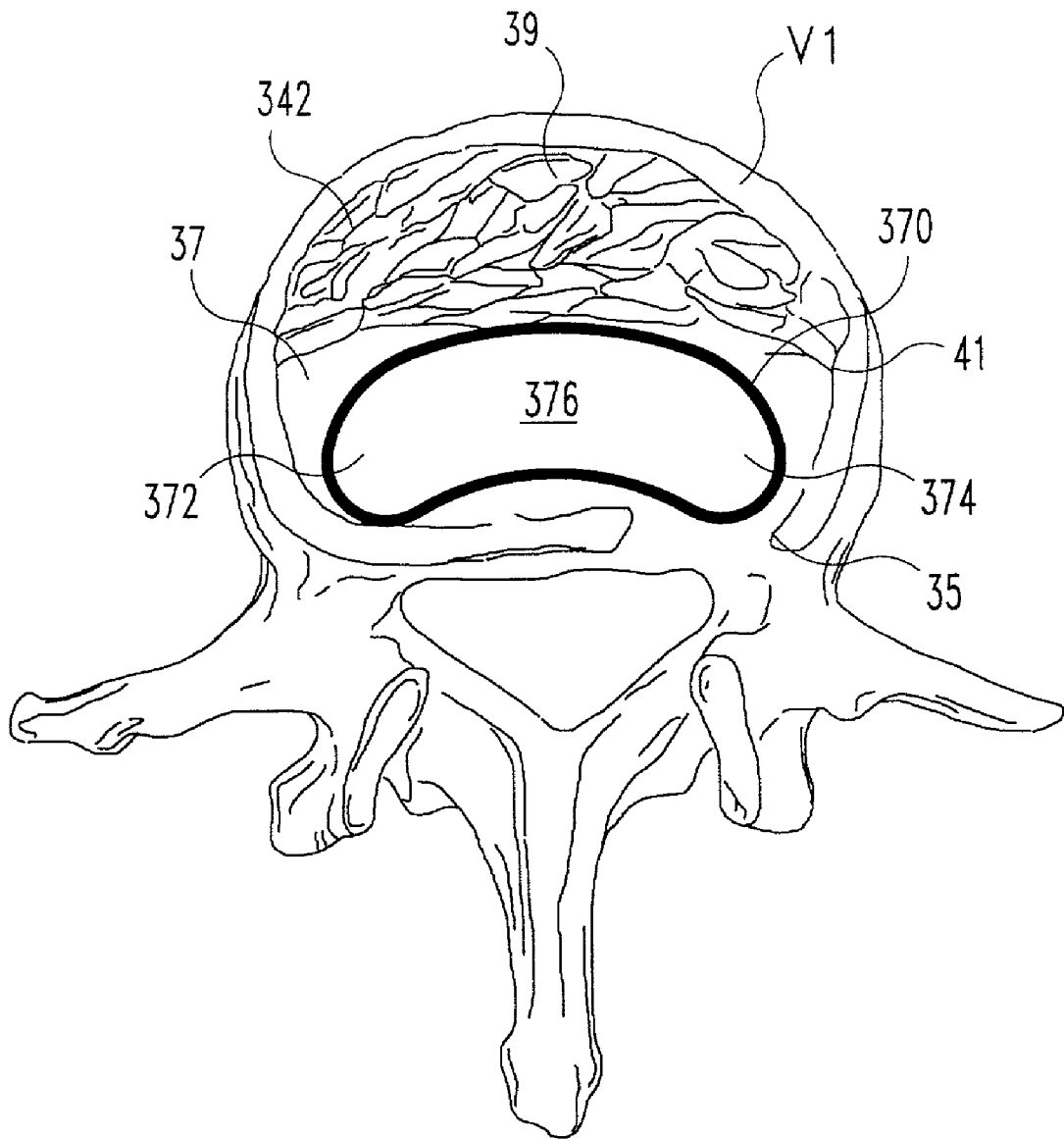




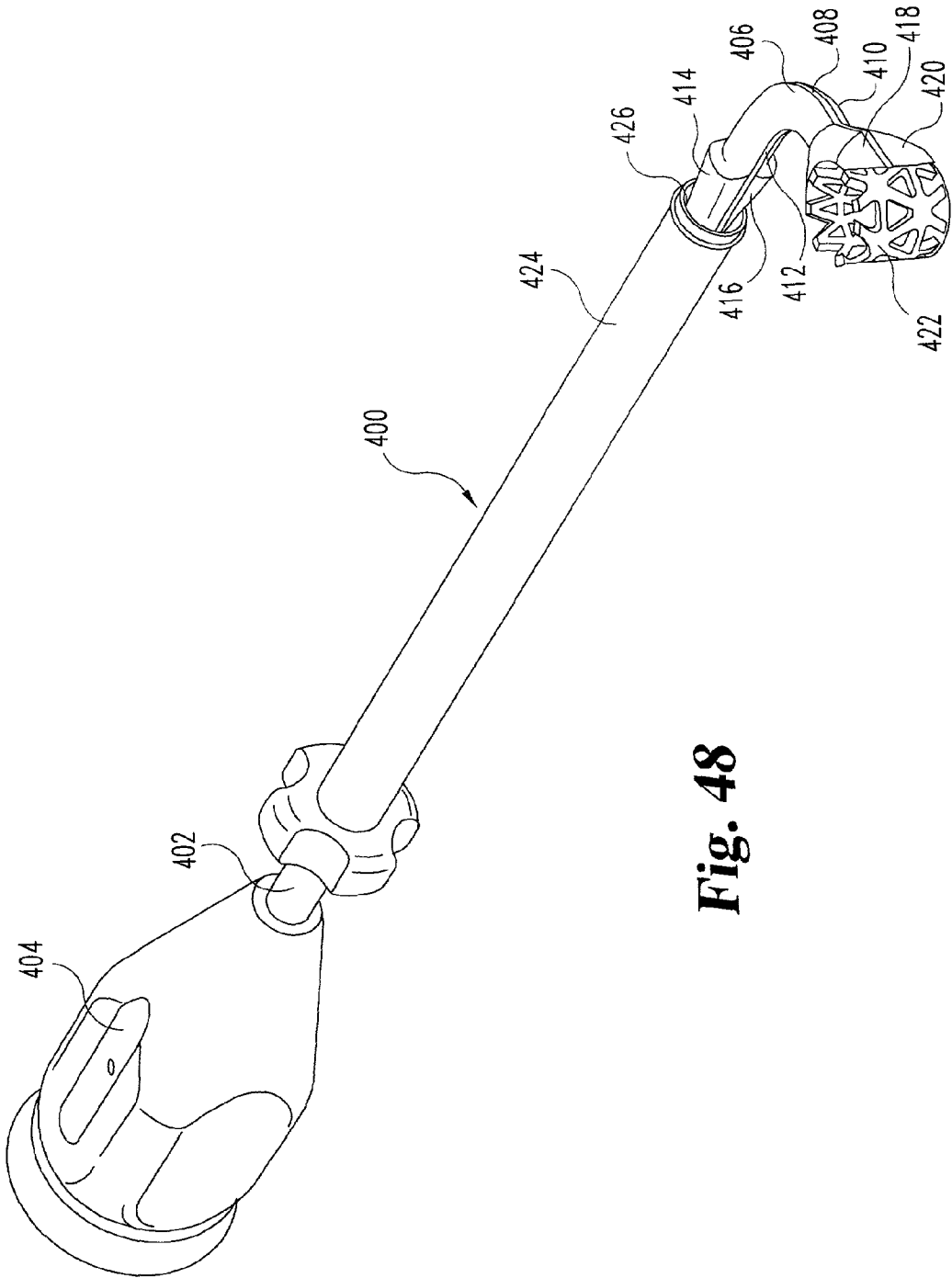
**Fig. 45**



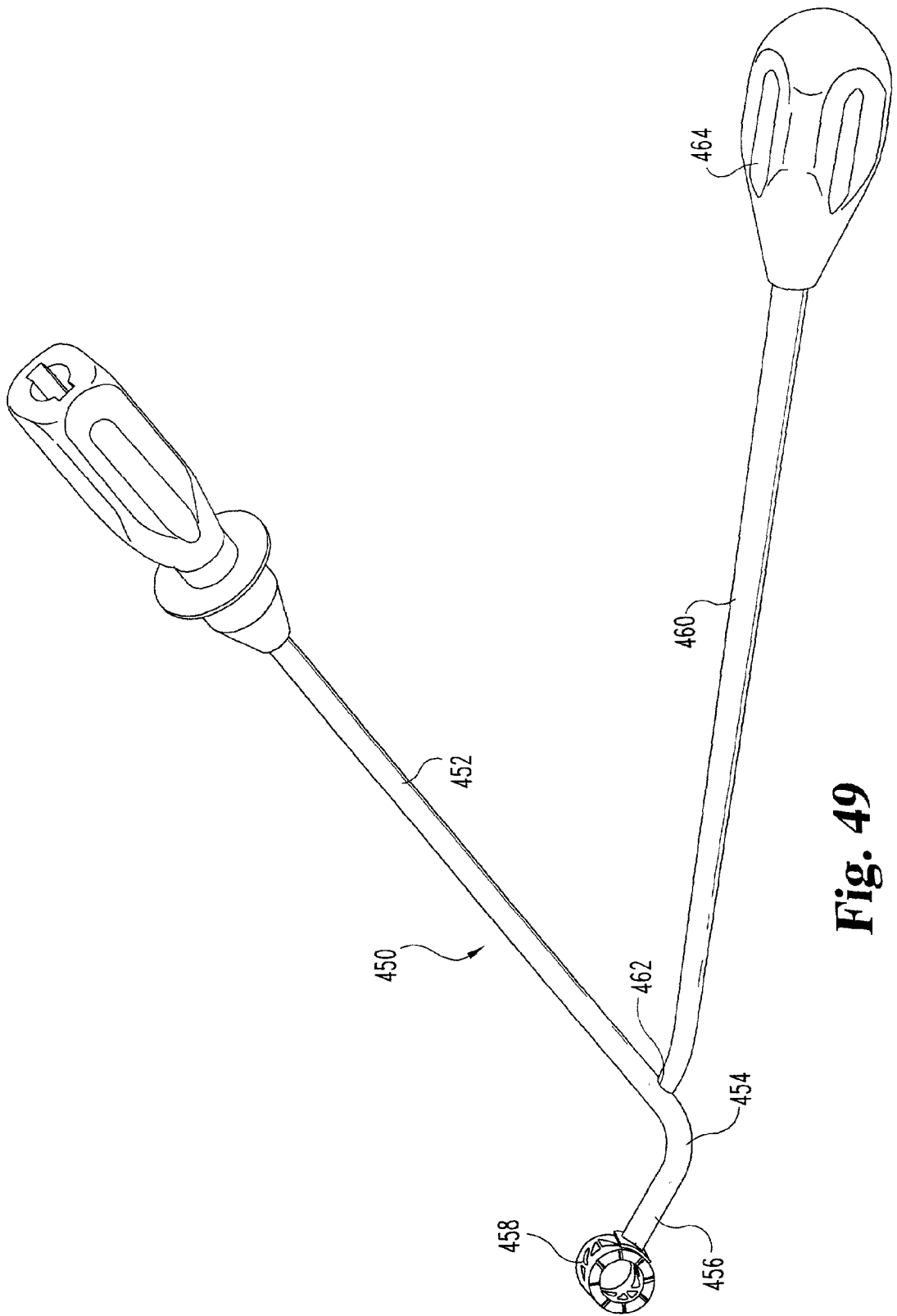
**Fig. 46**



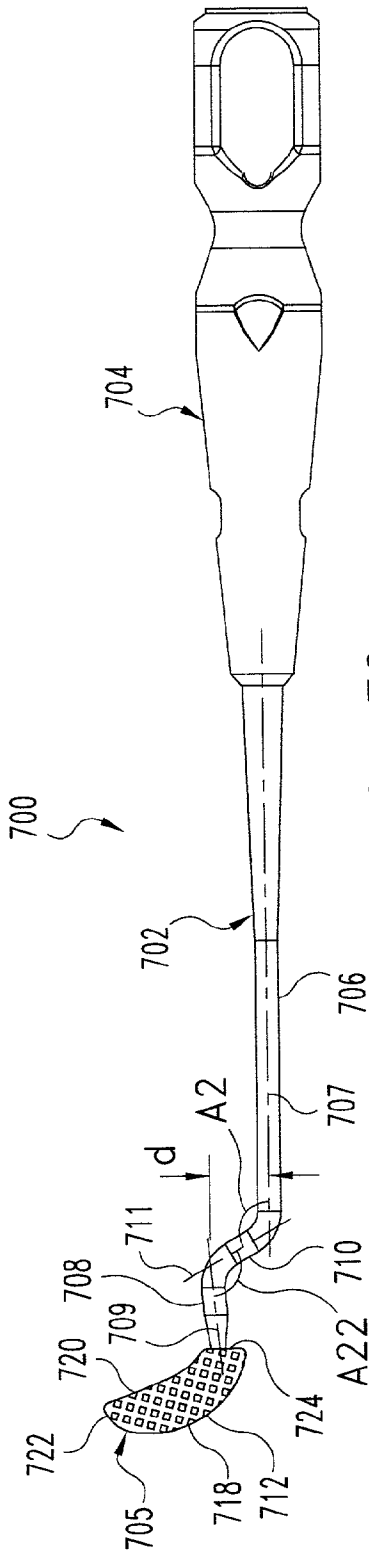
**Fig. 47**



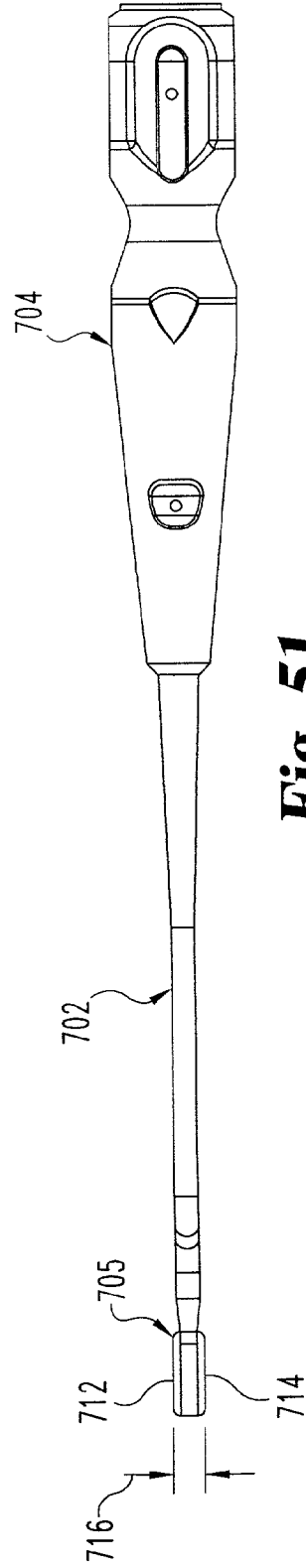
**Fig. 48**



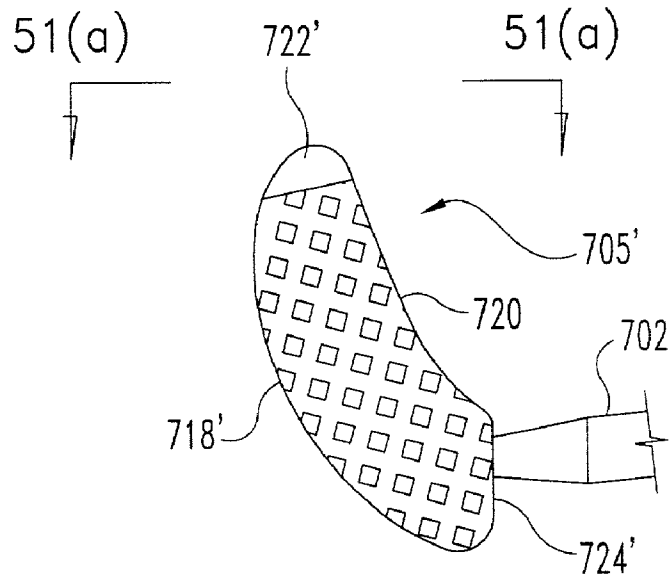
**Fig. 49**



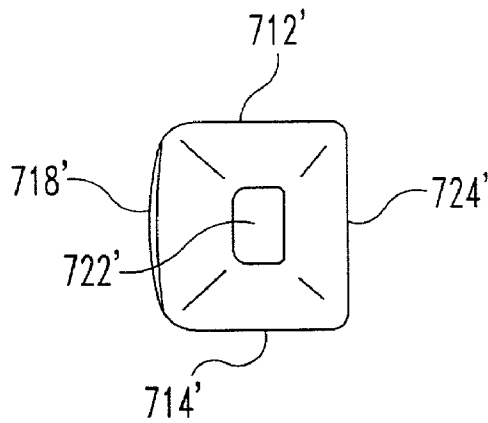
**Fig. 50**



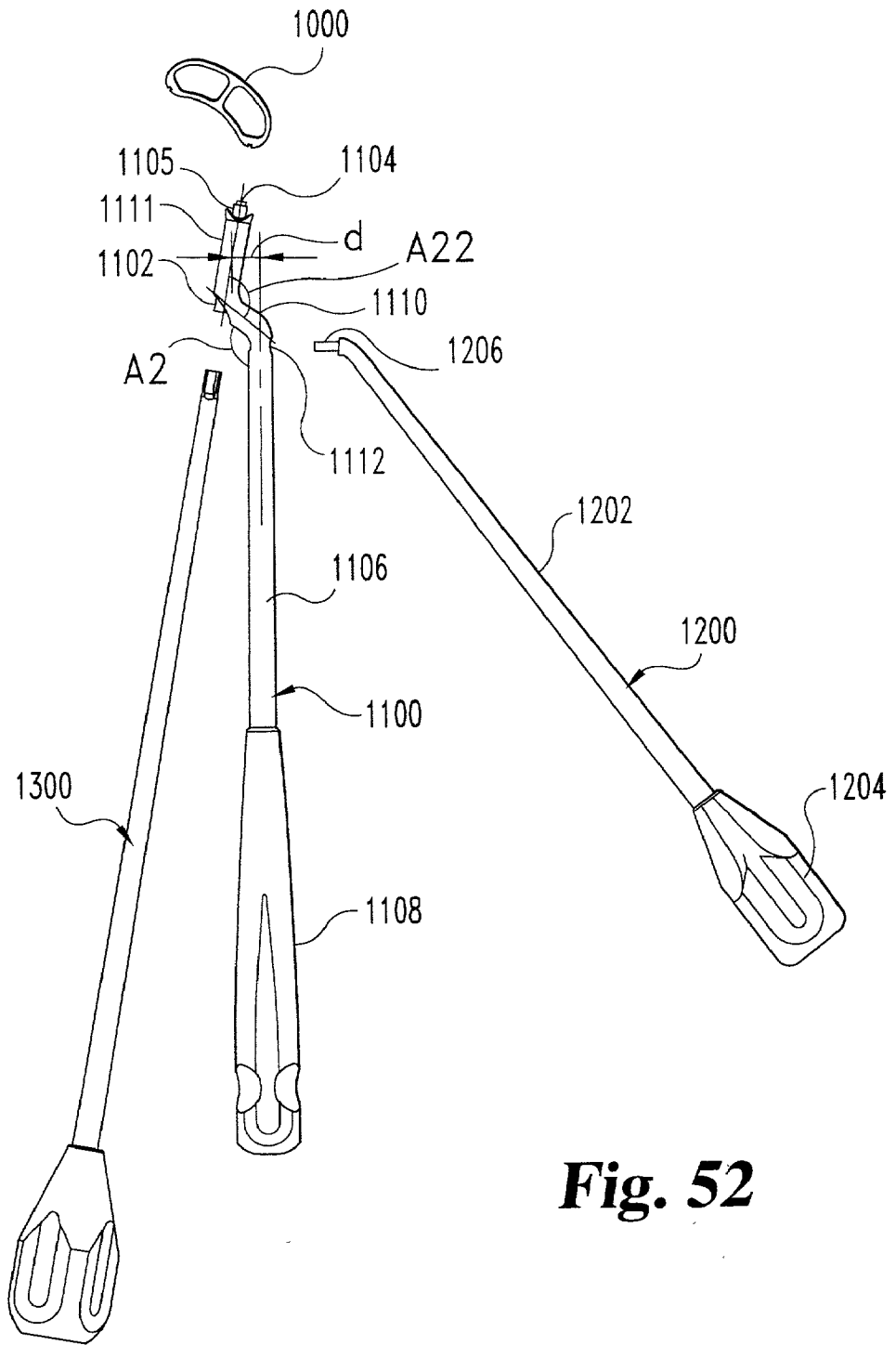
**Fig. 51**



**Fig. 50(a)**

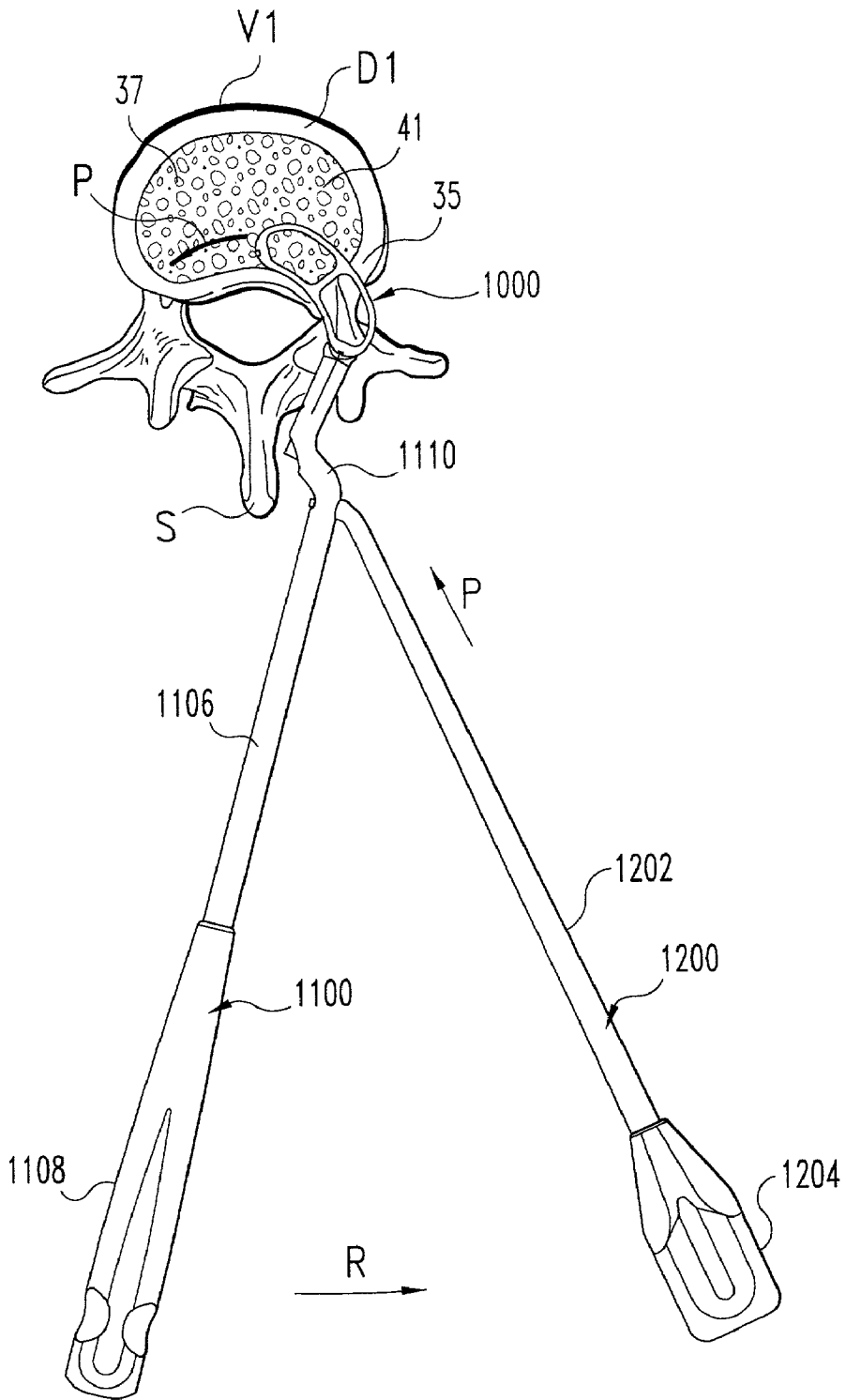


**Fig. 51(a)**

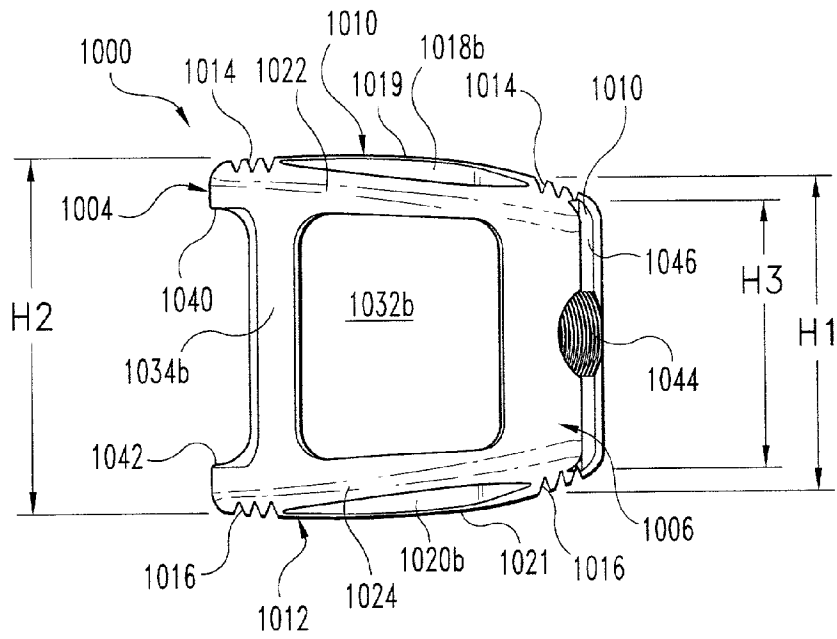


**Fig. 52**

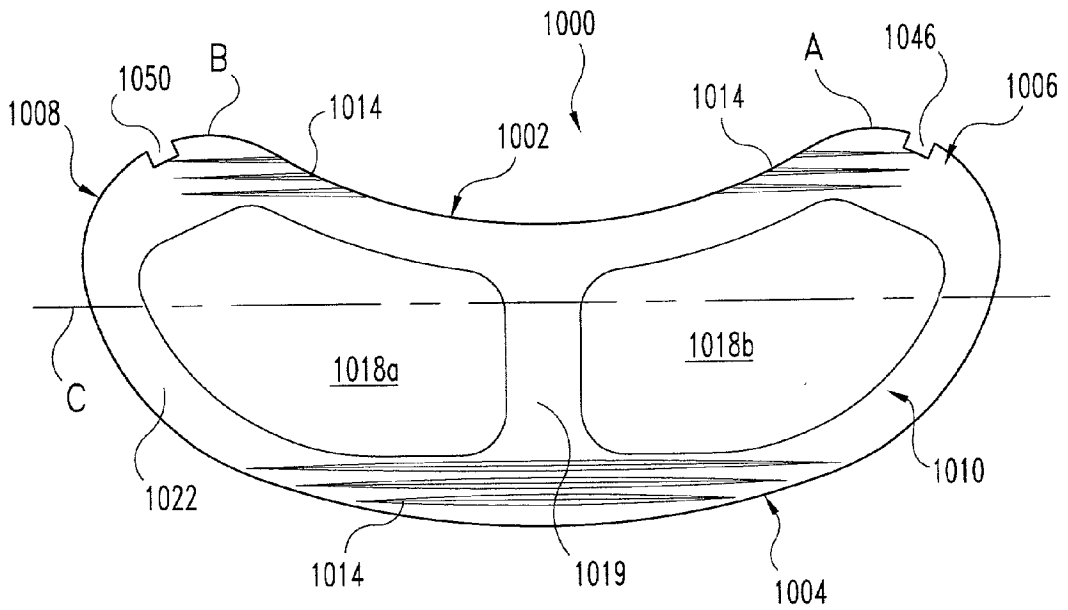




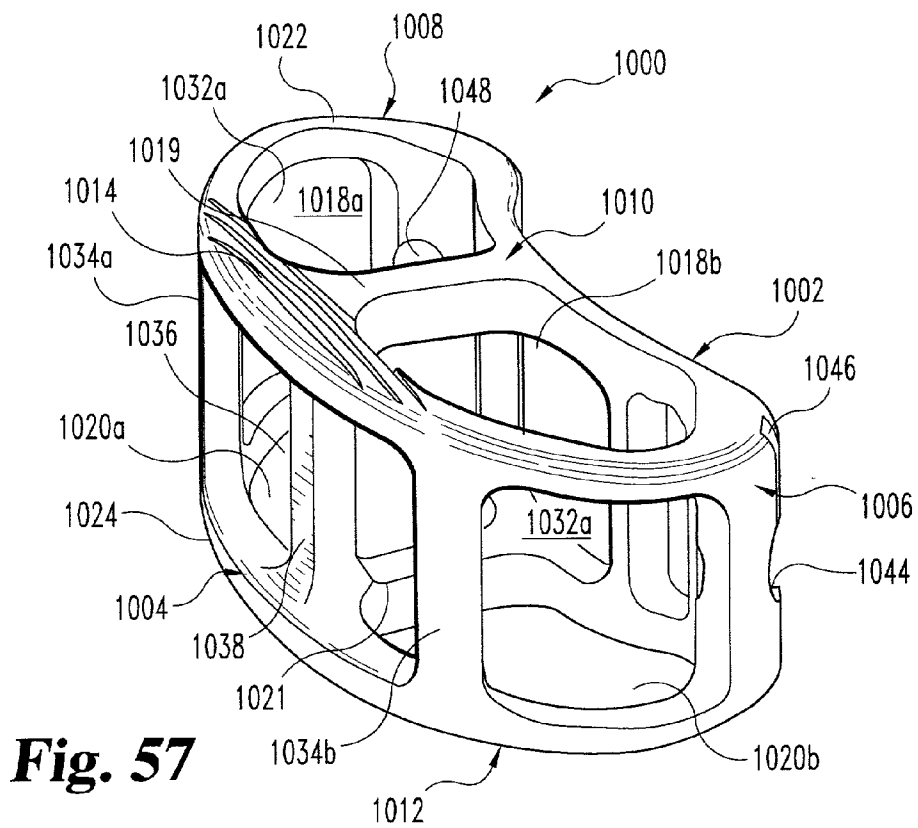
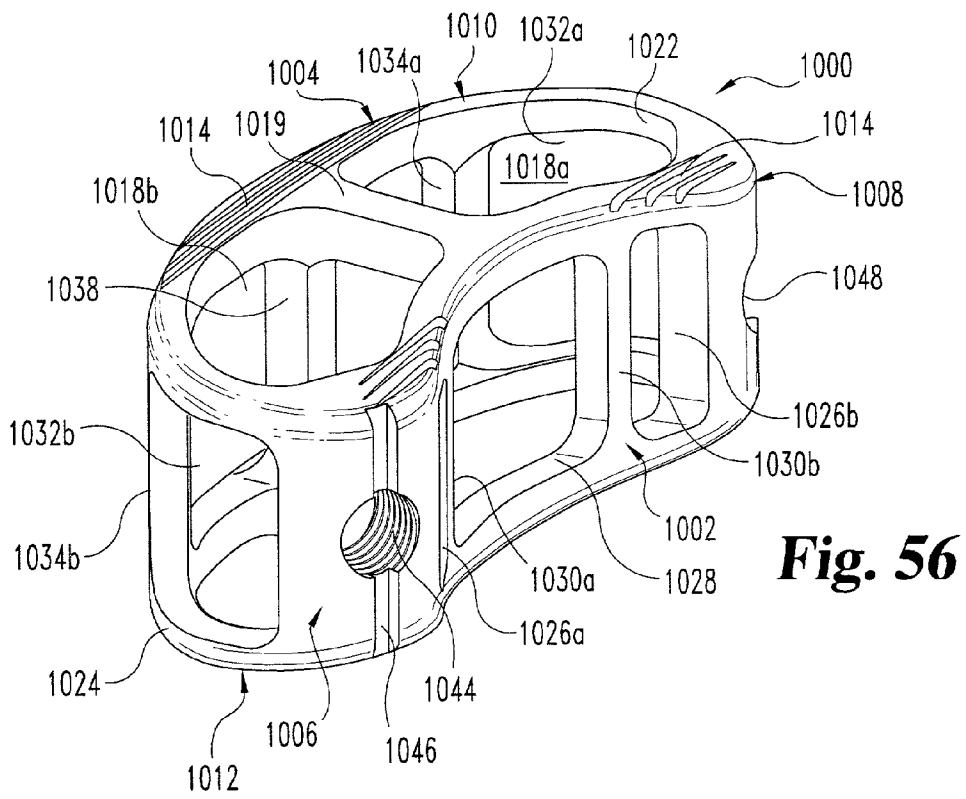
**Fig. 53**

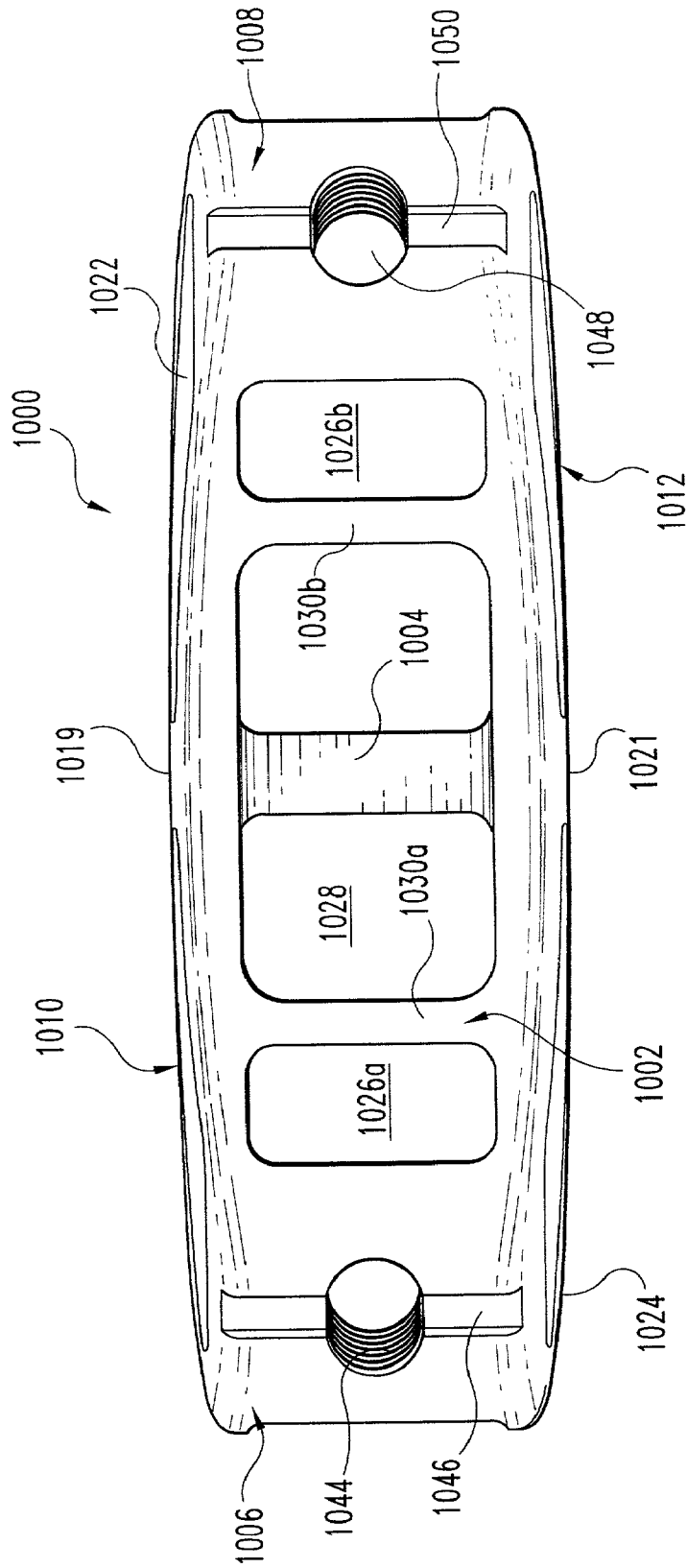


**Fig. 54**

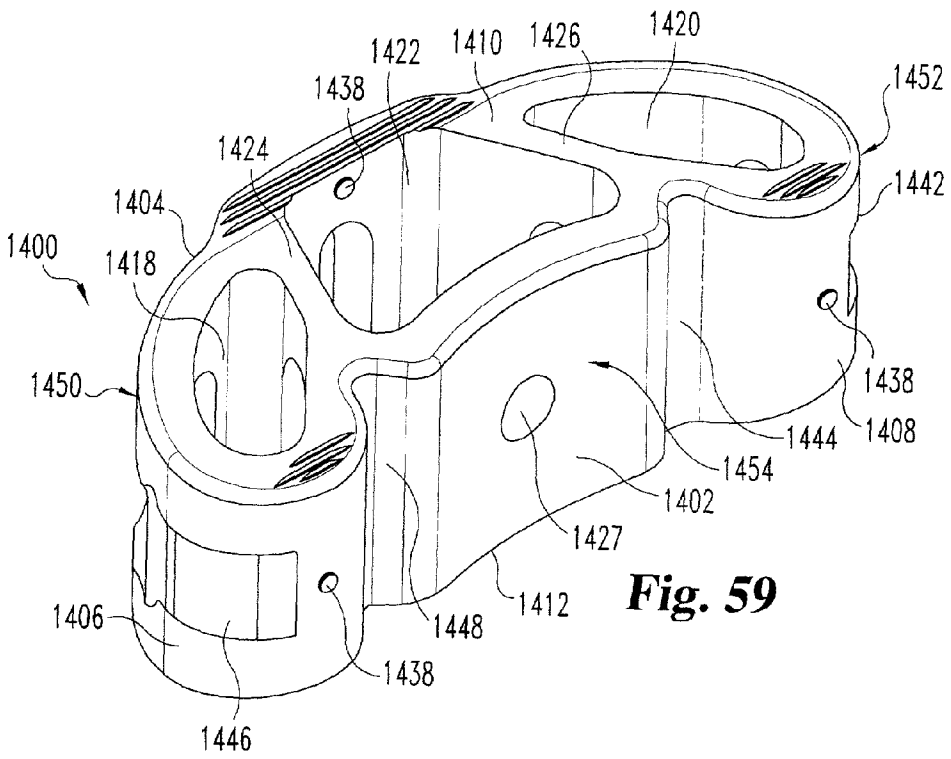


**Fig. 55**

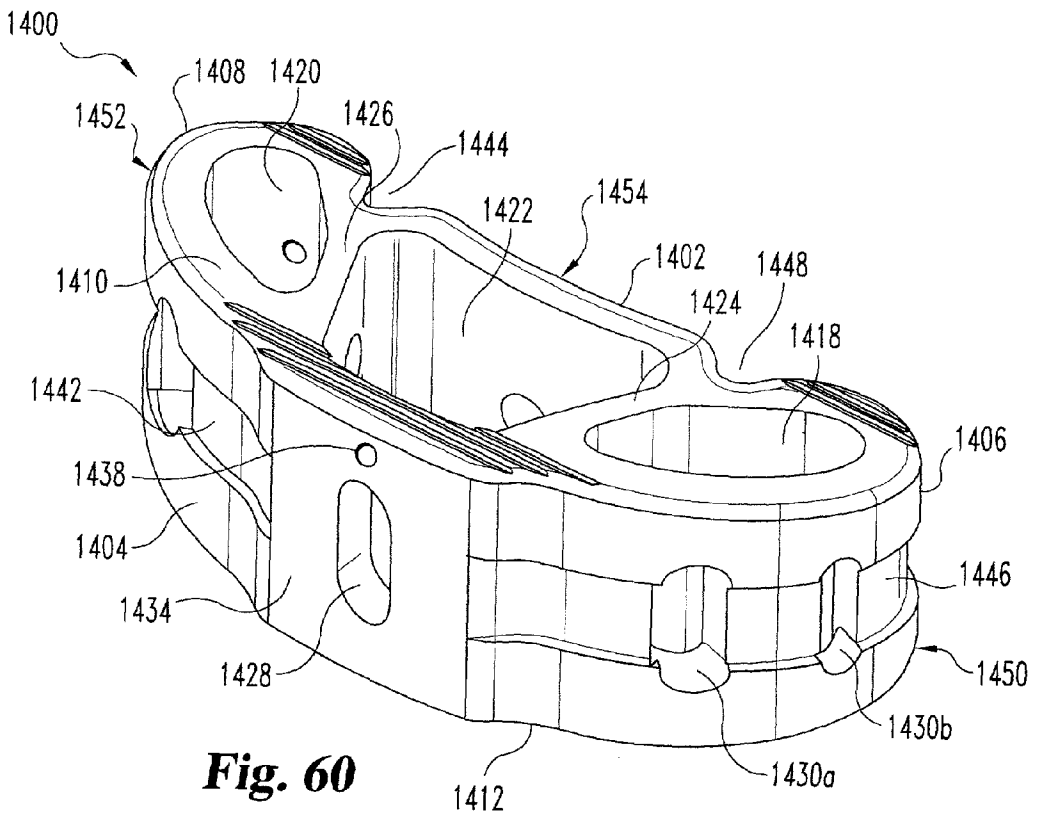




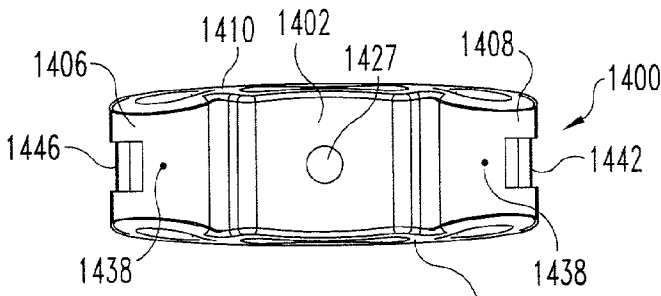
**Fig. 58**



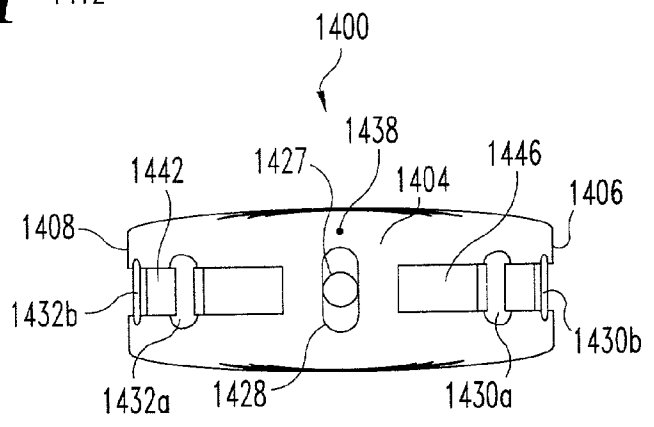
**Fig. 59**



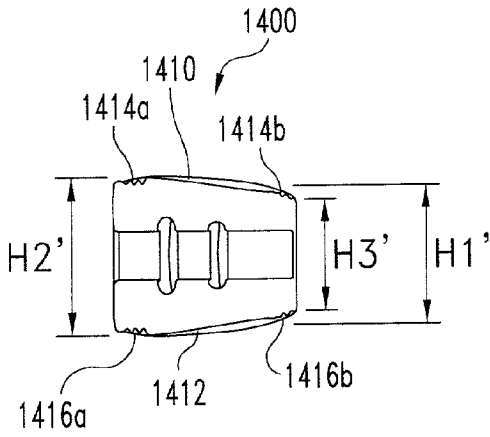
**Fig. 60**



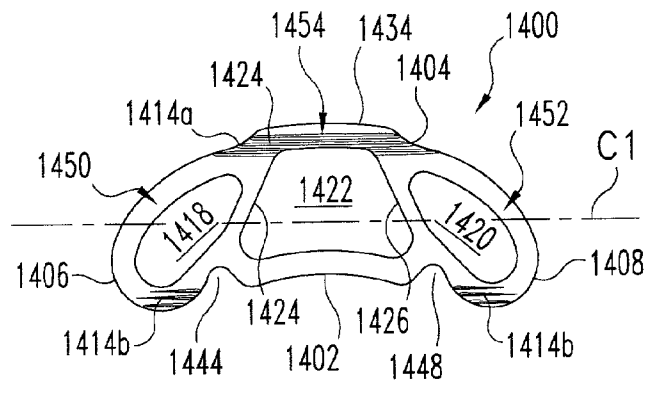
**Fig. 61**



**Fig. 62**

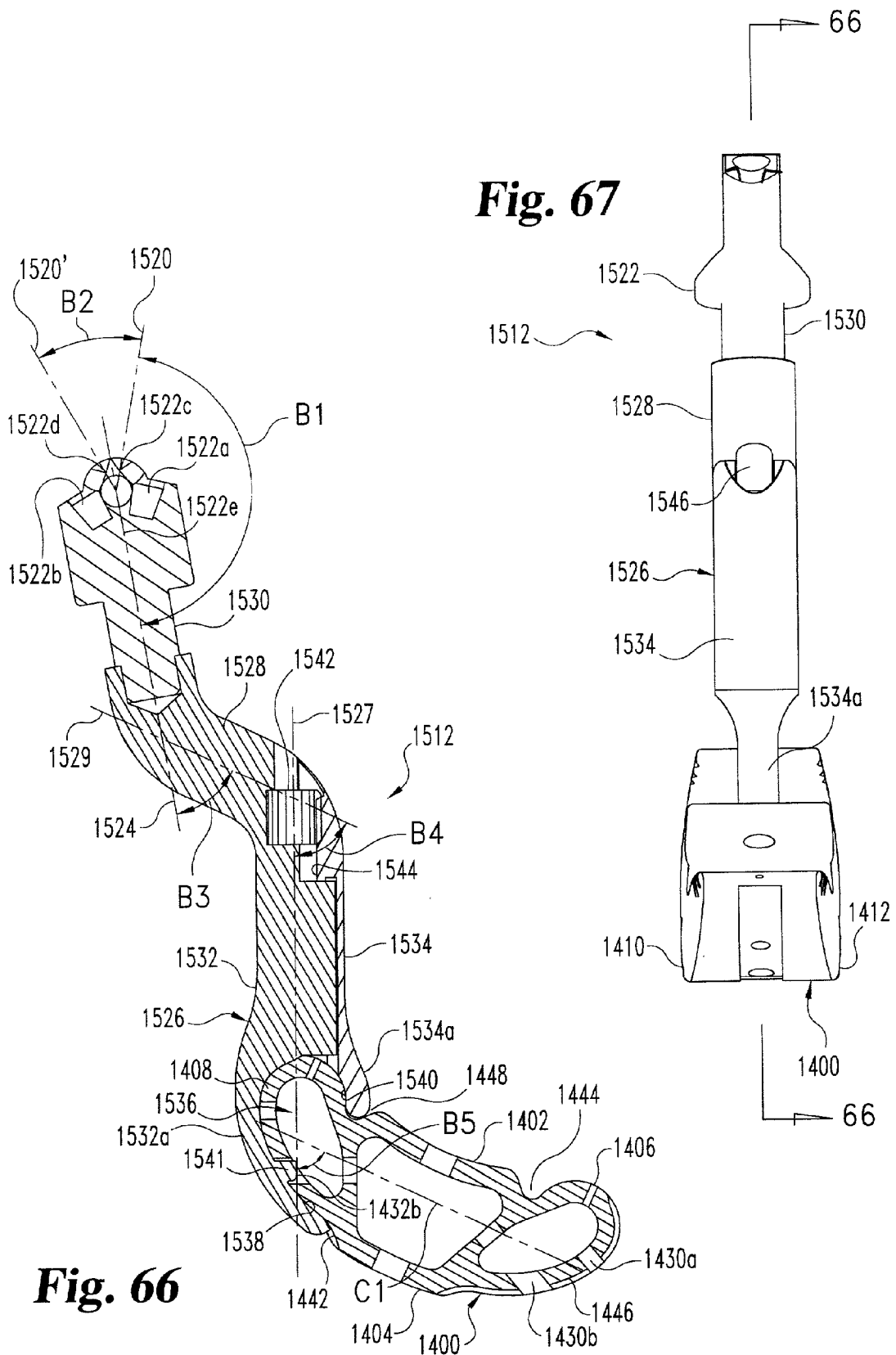


**Fig. 64**

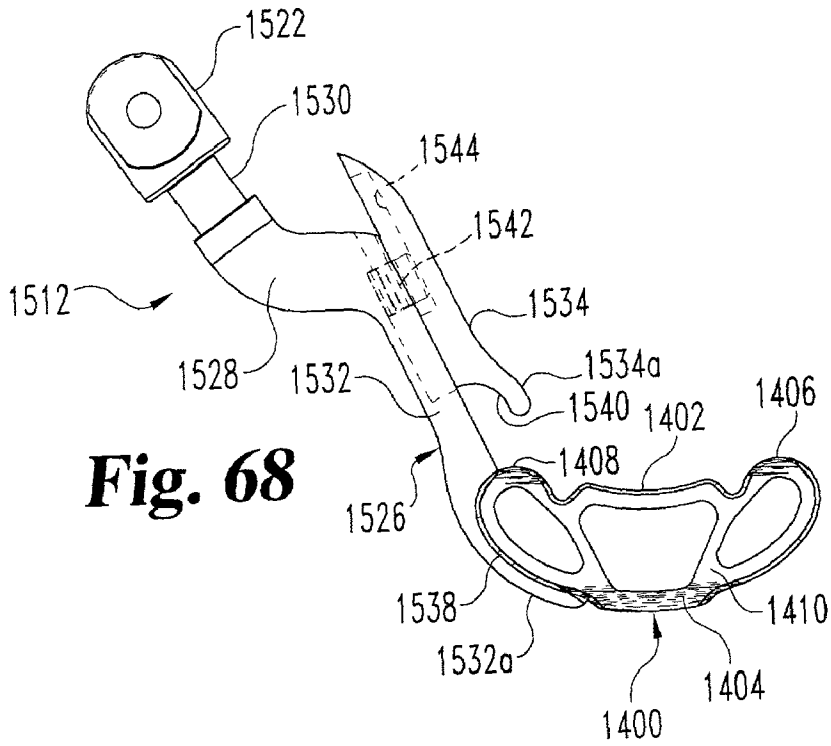


**Fig. 63**

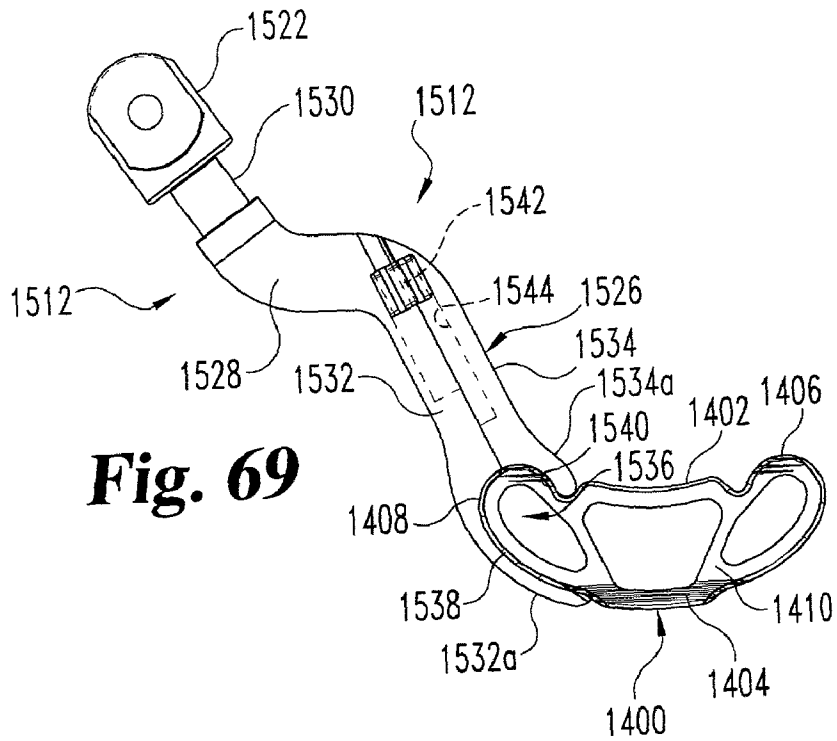




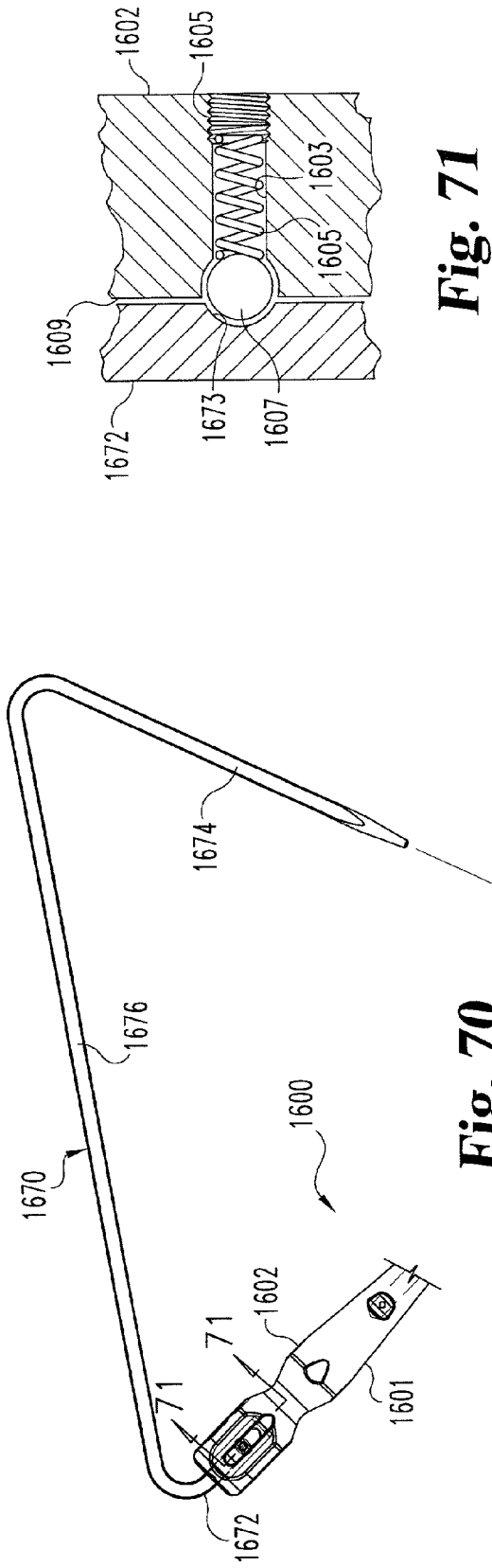




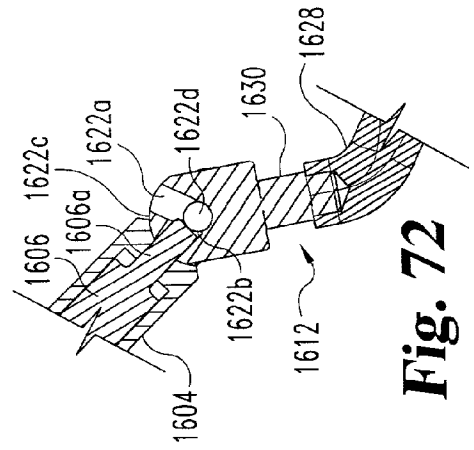
**Fig. 68**



**Fig. 69**



**Fig. 71**



**Fig. 72**

## DEVICES AND TECHNIQUES FOR A POSTERIOR LATERAL DISC SPACE APPROACH

### CROSS-REFERENCE TO RELATED APPLICATIONS:

[0001] The present application is a continuation-in-part of patent application Ser. No. 09/858,197 filed May 15, 2001, which is a continuation-in-part of U.S. patent application Ser. No. 09/694,521, filed on Oct. 23, 2000, which claims the benefit of the filing date of Provisional Application No. 60/160,667, filed Oct. 21, 1999.

### BACKGROUND OF THE INVENTION

[0002] The present invention relates to techniques for use in interbody fusion procedures, instruments for performing such procedures, and implants insertable in the spinal disc space. More specifically, but not exclusively, the present invention relates to implants, methods and instruments for use in a posterior lateral approach to the disc space, including a transforaminal approach.

[0003] Normally intervertebral discs, which are located between endplates of adjacent vertebrae, stabilize the spine and distribute forces between the vertebrae and cushion vertebral bodies. The spinal discs may be displaced or damaged due to trauma, disease or aging. A herniated or ruptured annulus fibrosis may result in nerve damage, pain, numbness, muscle weakness, and even paralysis. Furthermore, as a result of the normal aging processes, discs dehydrate and harden, thereby reducing the disc space height and producing instability of the spine and decreased mobility. Most typically surgical correction of a collapsed disc space includes a discectomy (surgical removal of a portion or the entire intervertebral disc). The discectomy is often followed by restoration of normal disc space height and bony fusion of the adjacent vertebrae to maintain the disc space height.

[0004] Access to a damaged disc space may be accomplished from several approaches to the spine. One approach is to gain access to the anterior portion of the spine through a patient's abdomen. However, extensive vessel retraction is often required and many vertebral levels are not readily accessible from this approach. A posterior approach may also be utilized. However, this typically requires that both sides of the disc space on either side of the spinal cord be surgically exposed. This may require a substantial incision or multiple access locations, as well as extensive retraction of the spinal cord. To alleviate problems associated with both anterior and posterior approaches to the spine, a posterior lateral approach, such as a transforaminal approach, to the disc space may be utilized. While it is desirable to place one or more implants in the disc space so that the load of the spinal column is evenly distributed, accurate placement of implants in the disc space from a single posterior lateral approach has heretofore been extremely difficult. Thus, this approach to the spine is seldom used in practice.

[0005] Therefore, there remains a need for improved instruments, implants and techniques for use in a posterior lateral approach to the disc space that allows unilateral disc space preparation and implant insertion to provide bilateral stability to the subject disc space.

### SUMMARY OF THE INVENTION

[0006] The present invention provides implants, instruments and methods particularly adapted for disc space preparation and implant insertion from a posterior lateral approach to the disc space.

### BRIEF DESCRIPTION OF THE DRAWINGS

[0007] FIG. 1 is a perspective view of a lamina spreader according to the present invention.

[0008] FIG. 2 is a perspective view of the lamina spreader of FIG. 1 with the handle portions rotated to a folded position.

[0009] FIG. 3 is an elevational view of a spinal column segment showing the distal portion of the lamina spreader of FIG. 1 engaged to the lamina on either side of a disc space.

[0010] FIG. 4 is a perspective view of a disc space spreader according to the present invention.

[0011] FIG. 4(a) is a plan view of the distal end of an alternate embodiment disc space spreader.

[0012] FIGS. 5(a) and 5(b) are perspective views of the disc space spreader of FIG. 4 with a lever arm and a perspective view of the lever arm, respectively.

[0013] FIG. 6 shows the sequence of the insertion of the disc space spreader of FIG. 4 into a disc space.

[0014] FIG. 7 is a perspective view of a distractor according to the present invention.

[0015] FIG. 8 is a perspective view of an alternative distractor having application in the present invention.

[0016] FIG. 9 is a top plan view of a vertebra with the distractor of FIG. 7 inserted in the disc space.

[0017] FIG. 10 is a perspective view of a straight reamer according to the present invention having the outer shaft partially cut-away to show the inner shaft.

[0018] FIG. 11 is a perspective view of a curved reamer according to the present invention having the outer shaft partially cut-away to show the inner shaft.

[0019] FIG. 12 is an end view of the reamer cutting head used with the reamers of FIGS. 10 and 11.

[0020] FIG. 13 is a top plan view of a vertebra with the straight reamer of FIG. 10 inserted in the disc space.

[0021] FIG. 14 is a top plan view of a vertebra with the curved reamer of FIG. 11 inserted in the disc space.

[0022] FIG. 15 is a perspective view of a guided rotary cutter according to the present invention.

[0023] FIG. 16 is an enlarged view of the distal end portion of the cutter of FIG. 15.

[0024] FIG. 17 is a top plan view of a vertebra with the cutter of FIG. 15 inserted in the disc space.

[0025] FIG. 18 is a perspective view of a guided rotary cutting tool according to the present invention.

[0026] FIG. 19 is an enlarged perspective view of the distal end portion of the cutting tool of FIG. 18.

- [0027] FIG. 20 is a top plan view of a vertebra with the cutting tool of FIG. 18 in the disc space.
- [0028] FIG. 21 is a perspective view of an alternative cutting tool head.
- [0029] FIG. 22 is a further perspective view of the cutting tool head of FIG. 21.
- [0030] FIG. 23 is a perspective view of a push scraper according to the present invention.
- [0031] FIG. 23(a) is section view taken through line 23(a)-23(a) of FIG. 23.
- [0032] FIG. 24 is a perspective view of a pull scraper according to the present invention.
- [0033] FIG. 24(a) is section view taken through line 24(a)-24(a) of FIG. 24.
- [0034] FIG. 25 is a top plan view of a vertebra with the push scraper of FIG. 23.
- [0035] FIG. 26 is a top plan view of a vertebra with the pull scraper of FIG. 24.
- [0036] FIG. 27 is a perspective view of a straight chisel according to the present invention.
- [0037] FIG. 28 is a lateral elevational view of a spinal column segment with the chisel of FIG. 27 inserted in the disc space.
- [0038] FIG. 29 is a posterior elevational view of a spinal column segment showing the disc space entrance created by the chisel of FIG. 27.
- [0039] FIG. 30 is a perspective view of an alternate embodiment guided chisel according to the present invention.
- [0040] FIG. 31 is an enlarged perspective view of the chisel head and shaft with the chisel head in the position of FIG. 30.
- [0041] FIG. 32 is a top plan view of a vertebra with the chisel of FIG. 30.
- [0042] FIG. 33 is a perspective view an implant sizing guide according to one aspect of the present invention.
- [0043] FIG. 34 is the implant sizing guide of FIG. 33 with the handle detached.
- [0044] FIG. 35 shows a perspective view of an implant insertion guide according to the present invention.
- [0045] FIG. 35(a) is an enlarged view of the distal end portion of the implant insertion guide of FIG. 35.
- [0046] FIG. 36 is a perspective view of a straight implant inserter according to the present invention having the outer shaft partially cut-away to show the inner shaft.
- [0047] FIG. 37 is a perspective view of a curved implant inserter according to the present invention having the outer shaft partially cut-away to show the inner shaft.
- [0048] FIG. 38 is a perspective view of an impaction tool according to the present invention.
- [0049] FIG. 39 is a top plan view of the disc space showing the sequence of the curved inserter of FIG. 37 inserting an implant into the disc space.
- [0050] FIG. 40 is a perspective view of an alternate embodiment guided implant inserter according to the present invention.
- [0051] FIG. 41 is an enlarged perspective view of the distal portion of the implant inserter of FIG. 40.
- [0052] FIG. 42 is an enlarged plan view of the distal portion of the implant inserter of FIG. 40 and an implant.
- [0053] FIG. 43 is the view of FIG. 42 showing the implant and insertion tool moved distally along the guide shaft.
- [0054] FIG. 44 is a top plan view of a vertebra with the implant inserter of FIG. 40 in the disc space.
- [0055] FIG. 45 is a top plan view of a vertebra with an implant inserted into the distal portion of the disc space.
- [0056] FIG. 46 is a top plan view of a vertebra with a pair of implants bi-laterally positioned in the disc space to provide bi-lateral support to the spinal column segment.
- [0057] FIG. 47 is a top plan view of a vertebra with a single implant positioned in the disc space to provide bi-lateral support to the spinal column segment.
- [0058] FIG. 48 is a perspective view of an alternate embodiment implant inserter.
- [0059] FIG. 49 is a perspective view of a still a further embodiment of an implant inserter.
- [0060] FIG. 50 is a plan view of an intradiscal rasp according to another aspect of the present invention.
- [0061] FIG. 50(a) is an enlarged view of an alternate embodiment head for the intradiscal rasp of FIG. 50.
- [0062] FIG. 51 is a side elevational view of the intradiscal rasp of FIG. 50.
- [0063] FIG. 51(a) is an elevational view of the head of FIG. 50(a) looking in the direction of arrows 51(a)-51(a).
- [0064] FIG. 52 is a top plan view of an implant and instrument set for inserting the implant into the disc space.
- [0065] FIG. 53 is a top plan view of the implant and instrument set of FIG. 52 with the implant partially inserted in the disc space.
- [0066] FIG. 54 is an end elevational view of an implant according to another aspect of the present invention.
- [0067] FIG. 55 is a top plan view of the implant of FIG. 54.
- [0068] FIG. 56 is a perspective of the implant of FIG. 54 oriented towards the posterior face.
- [0069] FIG. 57 is another perspective view of the implant of FIG. 54 oriented towards the anterior face.
- [0070] FIG. 58 is an elevational view of the implant of FIG. 54 looking towards the posterior face.
- [0071] FIG. 59 is a perspective view looking toward the posterior wall of another embodiment implant of the present invention.
- [0072] FIG. 60 is a perspective view looking toward the anterior wall of the implant of FIG. 59.

[0073] FIG. 61 is an elevation view looking at the posterior wall of the implant of FIG. 59.

[0074] FIG. 62 is an elevation view looking at the anterior wall of the implant of FIG. 59.

[0075] FIG. 63 is a plan view of the plant of FIG. 59.

[0076] FIG. 64 is an end elevation view of the implant of FIG. 59.

[0077] FIG. 65 is a sectional plan view of another embodiment implant insertion instrument according to the present invention engaged to the implant of FIG. 59, the sectional view illustrating first and second positions of a proximal portion of the implant insertion instrument.

[0078] FIG. 65a is a perspective view of a pusher instrument.

[0079] FIG. 66 is an enlarged sectional plan view of the implant insertion instrument and implant of FIG. 65.

[0080] FIG. 67 is a side elevation view of the implant insertion instrument and implant of FIG. 65.

[0081] FIG. 68 is an enlarged plan view of the implant insertion instrument and implant of FIG. 65 prior to engaging the implant to the implant insertion instrument.

[0082] FIG. 69 is an enlarged plan view of the implant insertion instrument and implant of FIG. 65 after engagement of the implant to the implant insertion instrument.

[0083] FIG. 70 is a partial elevation view the proximal portion of another embodiment inserter instrument and alignment instrument.

[0084] FIG. 71 is a section view through line 71-71 of FIG. 70 showing the attachment of the alignment instrument to the proximal portion of the inserter instrument.

[0085] FIG. 72 is an enlarged section view shown an alternate connection arrangement between the proximal portion and the implant engaging portion of the insertion instrument of FIG. 65.

#### DETAILED DESCRIPTION OF THE PREFERRED EMBODIMENTS

[0086] For the purposes of promoting an understanding of the principles of the present invention, reference will now be made to the embodiments illustrated in the drawings, and specific language will be used to describe the same. It will nevertheless be understood that no limitation of the scope of the invention is intended thereby. Any alterations and further modification in the described processes, systems, or devices, and any further applications of the principles of the invention as described herein are contemplated as would normally occur to one skilled in the art to which the invention relates.

[0087] In a posterior lateral approach to the disc space, such as is provided with a transforaminal approach, it is often difficult to prepare the proper locations in the disc space to receive an implant. The instruments and techniques of the present invention provide for improved unilateral disc space preparation in both the distal and proximal portions of the disc space through a single opening. Another difficulty in posterior lateral approaches to the disc space is related to the proper positioning of the implant in the portion of the disc space most distal from the posterior lateral opening. While

it is desirable that the implant be positioned in the distal portion of the disc space, it is often too difficult to move the implant across the disc space to the distal portion. Thus, the present invention further provides implant inserters, implant templates, implant insertion guides, and implants that facilitate implant positioning in the distal and proximal portions of the disc from a posterior lateral approach.

[0088] Referring now to FIG. 1, there is provided a lamina spreader 500 according to one aspect of the present invention. Lamina spreader 500 includes a first arm 502 pivotally joined to a second arm 504 by pin 506. Arms 502, 504 extend generally along a central axis 501 when in a first spreading position. Extending distally from pin 506 are distal portions 515 and 516 of arms 502 and 504, respectively. Distal portions 515 and 516 include lamina engaging portions 508 and 510, respectively. Lamina engaging portions 508 and 510 are generally U-shaped and configured to engage the lamina of an upper vertebra V2 and the lamina of a lower vertebra V1, respectively, on either side of the subject disc space, as shown in FIG. 3. Spreading portion 508 includes an outer portion 508a configured to reside on the outer side of the lamina connected to an inner portion 508b configured to reside on the inner side of the lamina. Spreading portion 510 similarly includes an outer portion 510a configured to reside on the outer side of the lamina connected to an inner portion 510b configured to reside on the inner side of the lamina.

[0089] The lamina can be spread by the surgeon grasping handle 502a of arm 502 and handle 504a of arm 504, and forcing arms 502, 504 towards one another in the direction towards axis 501. There is also provided a mechanism to force and/or maintain spreading portions 508 and 510 apart. The spreading mechanism includes an externally threaded rod 512 threadingly engaged to branch 502 and a hand nut 514 received on rod 512. Arms 502 and 504 may be forced together by action of threading nut 514 to force rod 512 into threaded opening 503 in arm 502, thereby forcing spreading portions 508 and 510 apart and separating the lamina to open access to the disc space. Nut 514 can also be used to thread rod 512 into opening 503 after manually spreading the lamina via handles 502a, 504a, until nut 514 contacts arm 504 to maintain the engaging portions 508, 510 in a spread condition.

[0090] In a preferred form, arm 502 has handle portion 502a that is hinged to rotate with respect to a non-rotating portion 502b about a pin 516, and arm 504 has handle portion 504a hinged to rotate with respect to a non-rotating portion 504b about a pin 518. A first spring loaded locking mechanism 520 resides in cut-out 524 formed in handle portion 502a, and a second spring loaded locking mechanism 522 resides in a similar cut-out (not shown) formed in handle portion 504a. Locking mechanism 520 includes a finger 528 spring-biased into notch 530 formed in non-rotating portion 502b. The surgeon or attendant can release handle portion 502a by pulling proximally on grasping portion 532 to pull finger 528 out of notch 530, and then rotate handle portion 502a transversely to axis 501 about pin 516 to a position oriented about 90 degrees with respect to non-rotating portion 502b. Similarly, locking mechanism 522 includes a finger spring-biased into a notch formed in non-rotating portion 504b. The surgeon or attendant can release handle portion 504a by pulling proximally on grasping portion 534 to pull the finger out of the notch, and then

rotate handle portion **504a** transversely to axis **501** about pin **518** to a position oriented about 90 degrees with respect to non-rotating portion **504b**. Rotating handle portions **502a**, **504a** moves this portion of lamina spreader out of the way of the surgeon and avoids interference with other instruments to be inserted in the disc space.

[0091] It is contemplated that spreader **500** can be used to assist the surgeon in gaining access to the disc space. The rotating handles allow lamina spreader **500** to remain in place during subsequent procedures. It is further contemplated that the surgeon may not desire to use lamina spreader **500**, and therefore proceed with disc space distraction after gaining access to the disc space.

[0092] Referring to FIG. 4 and FIGS. 5(a) and 5(b), a disc space spreader according to the present invention is shown. Disc space spreader **70** has a proximal portion that includes a first branch **72** pivotally joined to a second branch **74** by pin **76**. Extending distally from pin **76** are distal portions **85** and **86** of branches **72** and **74**, respectively. Distal portions **85** and **86** have a distal working end that includes spreading portions **80** and **78** that contact the endplates of the adjacent vertebrae to apply a distraction force thereto. Distal portions **85** and **86** further include lateral offset portions **81** and **79**, respectively, that laterally offset the branches **72**, **74** from the spreading portions **80**, **78**. Offset portions **79** and **81** have a straight portion extending generally parallel to central axis **88** extending between branches **72**, **74** and a bend forming a first offset angle **A2** with axis **88**. Spreading portions **78** and **80** form a second overall offset angle **A21** with axis **88**. In a preferred embodiment, offset angle **A2** is about 120 degrees, but it is contemplated that offset angle **A2** can range from 90 degrees to 160 degrees. Offset angle **A21** is about 110 degrees. The offset portions **79**, **81** laterally offset branches **72**, **74** from spreading portions **78**, **80**, allowing branches **72**, **74** to be further pivoted across the spinous process **S**, as shown by disc space spreader **70** in FIG. 6, than would be possible without offset portions **79**, **81**. In one form, the lateral offset distance **d** between axis **88** and the center of the straight portion is between 10 to 20 millimeters. This allows the distal tip of spreader **70** to be properly oriented into posterior lateral opening **35** formed in disc space **D1**.

[0093] To separate spreading portions **78**, **80** a force can be applied to the proximal ends of branches **72**, **74**. In a preferred embodiment, disc space spreader **70** includes a mechanism to force and/or maintain the separation of spreading portions **78** and **80**. The spreading mechanism includes an externally threaded rod **82** pivotally joined to branch **72** and positionable in notch **83** formed in the proximal end of branch **74**. The spreading mechanism has an internally threaded hand nut **84** threadedly received on rod **82**. Branches **72** and **74** may be forced together by action of internally threaded nut **84** on branch **74** forcing it towards branch **72**, thereby forcing spreading portions **78** and **80** apart. A spring blade **89** attached to branches **72**, **74** biases branches **72**, **74** apart.

[0094] Branches **72** and **74** also define opposing grooves **92** and **94** adjacent pin **76**. A lever arm or pusher **90** may be provided having an elongated shaft **96** with a handle **98** on one end and an opposing spreader engaging portion **99**. Engaging portion **99** is configured for removable engagement with opposing grooves **92** and **94** formed in branches

**72** and **74**, respectively. In se, removal of bony structures to gain access to the disc space and resection of disc material may be conducted by known methods. As shown in FIG. 6, the distal end of spreader **70** is positioned at opening **35**, and pusher **90** can be used to provide a pushing force in the direction of arrow **P** into the disc space during the steps of inserting the spreading portions **78** and **80** into opening **35**. Disc space spreader **70** is pivoted sequentially in the direction of arrow **R** about spinous process **S** via the proximal end of branches **72**, **74**. This pivotal and distal movement from proximal portion **41** to distal portion **37** of disc space **D1** is indicated by the relative sequential positions of spreader **70**, **70'**, **70''**, and **70'''** and spreader portions **78**, **78'**, **78''**, and **78'''**. Thus, branches **72**, **74** and pusher **90** enable the surgeon to have simultaneous two-handed control of spreader **70**, with one hand controlling insertion movement with pusher **90** and the other hand controlling pivotal movement with branches **72**, **74**. This positions spreading portions **78**, **80** across the disc space, and provides uniform disc space distraction so that the vertebral endplates will be parallel when distracted. The location of spreading portions **78**, **80** in the disc space may be checked by any known visualization techniques before proceeding to tissue removal.

[0095] It should be understood that pusher **90** is engaged to disc space spreader **70** during the steps indicated by spreaders **70'**, **70''** and **70'''**, but is not shown for purposes of clarity. The S-shaped connecting portions **79**, **81** provide a lateral offset to branches **72**, **74** to laterally offset branches **72**, **74** from spreader portions **78**, **80**. This allows branches **72**, **74** of disc space spreader **70** to avoid interference with the spinous process **S** when inserting the distal portions spreader portions **78**, **80** through opening **35** into disc space **D1**. Enlarged stops (not shown) can be formed on distal portions **85** and **86** in order to engage the adjacent vertebra during insertion and limit advancement of spreaders **78** and **80** into disc space **D1**. After the spreader is inserted into the disc space, lever arm **90** may be removed.

[0096] Disc space spreader **70** is manipulated as described above to spread or distract disc space **D1** to the desired height. In one procedure, it is contemplated that lamina spreader **500** is first used to spread the lamina. Since this tends to tilt the disc space and make the vertebral endplates non-parallel, spreader **70** can then be used to distract the distal portion of the disc space to provided parallel endplates. Disc space spreader **70** can remain in the disc space during subsequent procedures. It is further contemplated that lamina spreader **500**, pedicle screw fixation with rods or plates on the other side of spinous process **S** may be used to maintain the distracted disc space height so that disc space spreader **70** can be removed. Distraction shims may also be used to maintain disc space distraction, such as disclosed in co-pending application entitled METHODS AND INSTRUMENTATION FOR DISTRACTION OF A DISC SPACE, filed Oct. 20, 1999, U.S. patent application Ser. No. 09/421, 709, which application is incorporated herein by reference in its entirety. In another form, lamina spreader **500** is not used by the surgeon, and the surgeon only uses disc space spreader **70** to restore the normal disc space height.

[0097] In FIG. 4(a) there is shown an alternate form for the distal portions of disc space spreader **70** which facilitates spreader insertion through opening **35**. The proximal portion of the spreading instrument is similar to spreader **70** discussed above and will not be repeated here. Further, specific

references are made to one alternate distal portion in this description, it being understood that the second distal portion is identical thereto. In addition, a spreader utilizing these alternate distal portions can be used in the same manner as discussed above with respect to disc space spreader 70. Central axis 88 between branches 72, 74 is provided in FIG. 4(a) to orient distal portions 785, 786 with respect thereto. Distal portions 785, 786 each have a distal working end that includes spreading portion 778 that contacts the endplate of the adjacent vertebrae to apply a distraction force thereto. Distal portions 785, 786 further include branch extension 777 extending from a respective one of the branches 72, 74 along axis 88.

[0098] A first lateral inset 779 extends from proximal portion 777 and has a central axis 780 forming an angle A4 with respect to axis 88 such that first lateral inset 779 extends in a first direction away from axis 88. A lateral offset 781 extends from first lateral inset 779 and has a central axis 781 forming an angle A6 with central axis 88 and an angle A5 with central axis 780 such that lateral offset 781 extends in a second direction with respect to axis 88 opposite the first direction, positioning the distal end of lateral offset 781 on the side of axis 88 opposite first lateral inset 779. A second lateral inset 783 extends from lateral offset 781 and has a central axis 784 forming an angle A5 with central axis 782 and an angle A4 with central axis 88 such that second lateral inset 783 extends in the first direction towards axis 88. Thus, first lateral inset 779 and second lateral inset 783 are parallel to one another. Spreading portion 778 extends from second lateral inset 783 in the second direction away from axis 88 and has a central axis 787 forming an angle A5 with central axis 88. Central axis 787 is not parallel to central axis 782 of lateral offset 781.

[0099] In one specific embodiment, it is contemplated that angle A4 is about 10 degrees, angle A5 is about 125 degrees and angle A6 is about 45 degrees. In this specific embodiment, the length d1 along central axis 88 of first lateral inset 779 is about 21 millimeters, the length d2 of lateral offset 781 along axis 88 is about 11 millimeters, and the length d3 of second lateral inset 783 along axis 88 is about 15 millimeters.

[0100] Referring now to FIG. 7, another alternate embodiment disc space spreader/distracting mechanism is shown. Distractor 10 includes an elongated shaft 12 having a longitudinal axis 34. On the proximal end, distractor 10 includes a tool coupling 14 having a pair of opposed driving surfaces 16 and 18. On the opposite distal end, distractor 10 includes a distraction head 20 with a straight section 31 joined to shaft 12 by bend 32. Straight section 31 has a longitudinal axis 29 disposed at an angle A1 with respect to longitudinal axis 34. In a preferred embodiment angle A1 is between 120 and 160 degrees. Distraction head 20 is joined to straight section 31 and has a longitudinal axis 33 at an angle A11 with respect to axis 29. In one embodiment, angle A11 is between 20 and 60 degrees. Distraction head 20 includes a pair of opposed distraction flats 26 and 28 separated by a first height. A second pair of opposed flats 22 and 24 is separated by a second height, the second height being greater than the first height.

[0101] In an alternative embodiment to distractor 10 shown in FIG. 8, distractor 50 may include a lever arm 62 to assist in rotation of the distractor head after insertion into

the disc space. Distractor 50 includes a shaft 52 having a handle 54 opposite distractor head 56. As with the previous embodiment, distractor head 56 is joined to shaft 50 a lateral offset that includes a bend 58 and a straight section 59. Additionally, shaft 53 includes multiple holes 60, which preferably include an internal thread. Lever arm 62 has a connection end 66 adapted to be removably received in a selected one of the holes 60. Handle 64 tends to allow the surgeon to generate a substantial torque on head 56 to rotate head 56 in the disc space.

[0102] Referring to FIG. 9, distractor 10 may be utilized to distract adjacent vertebrae. Distractor head 20 may be inserted into disc space D1 through opening 35. Distractor head 20 may be inserted into the disc space D1 until the distal tip is positioned adjacent the distal portion 37 and straight section 31 is disposed in disc space D1 adjacent proximal portion 41. Distractor 10 is oriented during insertion in a reduced height configuration such that surface 26 of head 20 engages the endplate of vertebra V1. In a similar manner, surface 28 engages upper adjacent vertebra V2. Thus, distractor head 20 creates a distraction height approximating the distance between surfaces 26 and 28. Distractor shaft 12 is then moved to cause rotation about axis 33 of the distraction head 20 bringing surfaces 22 and 24 into contact with the opposing endplate surfaces, thereby distracting the disc space to the second, greater height between surfaces 22, 24. Lamina spreader 500, pedicle screw fixation with rods or plates may be used to maintain disc space height. Distraction shims may also be used to maintain disc space distraction.

[0103] According to a further aspect of the invention, various reamers are provided with the present invention to remove soft tissues from the disc space and the cartilage layer from the adjacent vertebral endplates. A straight reamer is illustrated in FIG. 10 and a curved reamer is illustrated in FIG. 11. Straight reamer 200 includes a hollow outer shaft 202 with a handle 204 attached to the proximal portion thereof. A rotatable inner shaft 206 is disposed within outer shaft 202. Rotary cutting head 210 having a cavity 213 is coupled to inner shaft 206. A Hudson type tool coupler 208 is provided at the proximal portion of inner shaft 206. It will be understood that a manual handle, such as a T-handle, may be attached to tool coupler 208. Application of rotation force on the inner shaft turns cutting head 210. Straight reamer 200 is inserted through opening 35 to remove material from proximal portion 41 of disc space D1, as shown in FIG. 13. Cutting head 210 of curved reamer 200 may be moved to various locations in the proximal portion 41 of disc space D1 and the cutting head reinserted to widen or alter a previously formed channel. A powered rotary driver may also be coupled to tool coupler 208 to mechanically drive inner shaft 206 and rotate cutting head 210.

[0104] Referring now to FIG. 11, curved reamer 220 includes a hollow outer shaft 222 with a handle 224 attached to the proximal portion thereof. A rotatable inner shaft 226 is disposed within outer shaft 222. Rotary cutting head 210 (identical to the head provided on reamer 200) having a cavity 213 is coupled to inner shaft 206. Outer shaft 222 includes a bend 221 angled at offset angle A3, permitting insertion of cutting head 210 through opening 35 and into distal portion 37 of disc space D1, as shown in FIG. 14. It is contemplated that A3 may range from 100 to 150 degrees. In one specific embodiment, angle A3 is about 125 degrees. Further, while a fixed bend is shown for the purpose of

illustration in FIG. 11, it is contemplated that outer shaft 222 may include a flexible portion or mechanical coupling permitting a plurality of angles for bend 221. Inner shaft 226 is preferably flexible at least through bend 221 so that rotary torque can be transmitted through bend 221. The flexible inner shafts used with the instruments of the present invention can be made from, for example, stainless steel coiled wire or nitinol.

[0105] A Hudson type tool coupler 228 is provided at the proximal portion of inner shaft 226. It will be understood that a manual handle, such as a T-handle, may be attached to tool coupler 228 to permit application of rotation force on the inner shaft and turn cutting head 210. Alternatively, a powered rotary driver may be coupled to tool coupler 228 to mechanically drive inner shaft 226 and rotate cutting head 210. As shown in FIG. 14, cutting head 210 of curved reamer 220 may be moved to various locations in the distal portion 37 of disc space D1 and the cutting head reinserted to widen or alter a previously formed channel. Thus, straight reamer 200 and curved reamer 220 allow the surgeon to remove disc material, cartilage and other tissue in both proximal portion 41 and distal portion 37 of disc space D1 through opening 35.

[0106] As shown in FIG. 12, cutting head 210 includes cutting edges 211a, 211b, 211c, and 211d. Cutting head 210 has a smooth, non-cutting profile between edges 211a, 211d and between edges 211b, 211c. It is contemplated that head 210 is inserted with the non-cutting profiles oriented towards the vertebral endplates to provide smooth insertion and positioning of cutting head 210 in the disc space. The location of cutting head 210 in the disc space may be checked by any known visualization techniques before proceeding to tissue removal. When cutting head 210 is rotated in direction R1, edges 211a and 211c cut tissue and cartilage, while edges 211b and 211d pass over the tissue without cutting. The cut material is deposited in cavity 213, where it may then be extracted from the disc space. Cutting head 210 provides a safe and efficient discectomy tool that preserves the bony endplate surface and quickly collects the soft tissue.

[0107] Other embodiments of cutting instruments are provided that include a guide member for controlled cutting within the proximal and distal portions of the disc space. Referring to FIGS. 15 and 16, a guided rotary cutter is disclosed. Cutter 100 includes a guiding shaft 102 having an interconnected handle 109 disposed on the proximal end and a stop 106 disposed on the opposing distal end. Stop 106 may be substantially radiopaque to provide an indication of inner shaft location on x-ray images. Distal portion 103 is joined to shaft 102 by bend 104. Bend 104 is preferably a substantially uniform curve creating angle A3 between axis 105 of shaft 102 and axis 107 of distal portion 103.

[0108] Disposed on guide shaft 102 between handle 109 and stop 106 is an outer shaft 108. Outer shaft 108 includes a handle 110 on a proximal end and a flexible drive 112 on the opposing distal end. A cutting head 114 is interconnected with flexible drive 112. As shown more clearly in FIG. 16, cutting head includes a number of cutting blades configured for rotary cutting. Flexible drive 112 is designed to transmit both longitudinal force to advance cutting head along guiding shaft 102 in the direction arrow 116 and also transmit rotation force in the direction of arrow 118 to move cutting

head 114 in a circular manner about shaft 102, thereby engaging cutting blades 120 with adjacent tissues. While other flexible drives, such as, for example but without limitation, cables and mechanical couplings may be utilized, in a preferred embodiment flexible drive 112 is a helically wound cable.

[0109] Referring to FIG. 17, cutter 100 may be inserted into disc space D1 through opening 35. Preferably, stop 106 is positioned adjacent distal disc space portion 37 and bend 104 may be positioned centrally in the disc space. The location of guide shaft 102 in the disc space may be checked by any known visualization techniques before proceeding to tissue removal. Once the proper positioning of the guide shaft 102 has been established, force is applied to handle 110 to advance cutting head 114 into contact with structures adjacent the disc space. Forward pressure in the direction of arrow 116 may be maintained as rotational force in the direction of arrow 118 is transmitted to cutting head 114. As tissue is removed cutting head 114 may cuttingly advance along guide shaft 102 until it reaches stop 106. Cutting head 114 has an internal channel (not shown) sized to receive shaft 102 but limited in size and shape such that the cutting head may not extend beyond stop 106. As will be understood by the illustrations, cutting tool 100 forms an arcuate channel through the disc space by following guiding shaft 102. Guide shaft 102 may be moved to one or more new locations in the disc space and the cutting head reinserted to widen or alter a previously formed channel in disc space D1.

[0110] A further embodiment of a rotary cutting device is disclosed in FIGS. 18 through 20. Shaver 150 includes a guide rod 152 with a handle 158 disposed at the proximal end and a stop 156 disposed on the distal end. Guide rod 152 includes bend 154 adjacent the distal end. Outer shaft 160 is slidably mounted on guide rod 152. Outer shaft 160 includes a handle 162 on its proximal end and is coupled to flexible drive 164 on its distal end. A shaving head 166 is mounted on flexible drive 164. Preferably, shaving head 166 has a plurality of cutting blades adapted to shave tissue as the head is rotated. In one aspect, individual blades of head 166 are elongated and include a forward cutting blade 168 and backward cutting blade 170 and a cavity 169 for deposit of material. Still more preferably, shaving head 166 has sufficiently flexibility to allow it to conform at least partially to bend 154 as it is advanced along guide rod 152 towards stop 156.

[0111] In use, shaver 150 may be positioned in disc space D1 with stop 156 disposed adjacent distal disc space portion 37 as shown in FIG. 20. Preferably, shaver 150 will follow use of cutter 100 to further define and expand the arcuate channel defined in the disc space. As shaver head 166 is advanced in the direction of arrow 174, handle 162 may be rotated thereby rotating head 166 in the direction of arrow 173 to cut tissue, and cut tissue can be accumulated between the blades and in cavities 169 for removal from disc space D1. Shaver head 166 preferably cuts in both directions, however it is also contemplated that the shaver may be unidirectional.

[0112] Referring now to FIGS. 21 and 22, an alternative shaver head 180 is illustrated. Shaver head 180 is slidably disposed on inner shaft 182 and may be advanced along the shaft until it reaches stop 186. Shaver head 180 includes a flexible drive portion 190 and a helical cutting blade 188



disposed on the distal portion of the flexible drive. Thus, as flexible drive 190 rotates, helical blade 188 cuts the tissue and accumulates tissue between the blades for removal from the disc space.

[0113] Referring to FIGS. 23-26, further cutting instruments according to the present invention are shown. In FIG. 23 there is illustrated a push scraper 260. Push scraper 260 includes an elongated shaft 262 with a handle 264 on the proximal end and a push scraper head 265 on the distal end. Scraper head 265 is joined to and is substantially perpendicular to shaft 262. As shown in FIG. 23(a), scraper head 265 includes distally facing upper and lower cutting blades 266 having a distal concave face 267 with a hole 268 formed therein. Concave face 267 forms a trough around hole 268. The proximal face 269 of scraper head 265 has a smooth, convex non-cutting profile to facilitate proximal movement of scraper head 265 through the disc space. As shown in FIG. 25, push scraper 260 is inserted through opening 35 with scraper head 265 initially positioned towards proximal portion 41 of disc space D1. Push scraper 260 is then pivoted and pushed distally through disc space D1, as indicated by push scraper 260', to position scraper head 265' towards distal portion 37 of disc space D1. Distally facing blades 266 remove disc material and can deposit at least some of the material in the trough between blades 266 during this distal pivotal movement for subsequent removal. A pusher as described herein can be used to facilitate this distal pivotal movement.

[0114] In FIG. 24 there is illustrated a pull scraper 270 includes an elongated shaft 272 with a handle 274 on the proximal end and a pull scraper head 275 on the distal end. Scraper head 275 is joined to and extends substantially perpendicular to shaft 272. Scraper head 275 includes proximally facing cutting blades 276 and a concave proximal face 277 with a hole 278 formed therein. Concave face 277 forms a trough around hole 278. The distal face 279 of scraper head 275 has a smooth, convex non-cutting profile to facilitate distal movement of scraper head 275 through the disc space. As shown in FIG. 26, pull scraper 270 is inserted through opening 35 and scraper head 275 is pushed through disc space D1 to initially position scraper head 275 towards distal portion 37 of disc space D1. Pull scraper 270 is then pivoted and pulled proximally through disc space D1, as indicated by pull scraper 270', to position scraper head 275' towards proximal portion 41 of disc space D1. Proximally facing blades 276 remove any remaining disc material and can deposit at least some of the material in the trough between blades 276 during this proximal pivotal movement for subsequent extraction.

[0115] When the desired amount material has been removed from disc space D1 using the instruments described above, a straight chisel 540 as shown in FIG. 27 is provided for preparing a square entrance port into disc space D1 for implant insertion. Chisel 540 includes shaft 542 having a handle 544 coupled to the proximal end of shaft 542. A chisel head 546 is provided at the distal end of shaft 542. Chisel head 546 includes a body portion 547 having a pair of non-cutting extensions 548 extending distally therefrom. Extensions 548 have an upper surface 548a for contacting vertebra V2 and a lower surface 548b for contacting lower vertebra V1. Extensions 548 guide chisel head 546 into the disc space, ensuring equal amounts of material are removed from the endplates of the upper and lower vertebrae by upper

cutting edge 550 and lower cutting edge 551. V-shaped portions 552, 553 distally offset edges 550, 551, respectively, with respect to body portion 547. A chamber 554 is formed in body portion 547, and body portion 547 has upper and lower openings positioned proximally of the upper and lower cutting edges 550, 551. Cut material can be deposited through these upper and lower openings and into chamber 554.

[0116] Referring now to FIG. 28, chisel 540 is shown with extensions 548 in disc space D1. Chisel head 546 is impacted into the disc space, with cutting edges 550, 551 removing bone material and osteophytes from the vertebral endplates. This provides, as shown in FIG. 29, an enlarged squared entrance to disc space D1 is formed at the proximal portion of the disc space that is larger than the opening created by spreading the lamina and distracting disc space D1. This enlarged entrance facilitates implant insertion into the disc space. The material removed to form the enlarged entrance is indicated by cut-away portions C in vertebra V1 and V2.

[0117] Referring now to FIGS. 30 through 32, there is shown a guided chisel which can be used, if desired, to remove material from distal portion 37 of disc space D1. Chisel 230 includes an inner shaft 232 with a handle 238 connected to the proximal end and a stop 236 formed on the distal end. As shown in FIG. 31, inner shaft 232 preferably has a non-circular cross section 233 adjacent the distal portion. The non-circular cross section, preferably square, inhibits rotation of the chisel cutting head as it is impacted along inner shaft 232. Outer shaft 240 is slidably disposed about inner shaft 232. Outer shaft 240 includes a drive region 242 with an impact shoulder 244. Outer shaft 232 is coupled to chisel head 248 by flexible drive 246. Chisel head 248 includes an upper cutting edge 254 and a lower cutting edge 252. The cutting blades are spaced by extensions 249 and 251 that control and limit the depth of penetration of the cutting edged into the endplates.

[0118] As shown in FIG. 32, inner shaft 234 is positioned in disc space D1 through opening 35. Stop 236 is position adjacent the distal portion 37 of disc space D1. Visualization of the placement of inner shaft 234 may be made to confirm proper positioning. Once the position is confirmed, chisel head 248 is advanced along inner shaft 232 in the direction of arrow 250. If necessary, a forked slap hammer or pusher may be positioned with the forks extending on either side of drive region 242. The slap hammer may then be forcibly urged against impact shoulder 244 to drive chisel head 248 into the disc space. The chisel head is advanced until it engages stop 236. This action forms a substantially square or rectangular arcuate channel extending into each of the adjacent vertebral endplates.

[0119] Referring now to FIGS. 33 through 34 there is provided an implant template inserter 560 according to another aspect of the present invention. Template inserter 560 includes a shaft 562 having a handle 564 detachably secured to the proximal end of shaft 562. A bend 566 is secured to the distal end of shaft 562 and forms offset angle A3. A template 568 is secured at the distal end of bend 566. A notch 567 is provided in shaft 562 that is engageable by a pusher, such as pusher 670 described below, to facilitate placement of template 568 into disc space D1. Template 568 is positionable through opening 35 into the distal portion of

disc space D1 to determine if enough material has been removed from the disc space to accommodate the implant to be inserted therein, or to determine the size of implant required. Handle 564 is removable for fluoroscopic or radiographic imaging of template 568 in disc space D1, allowing the surgeon to confirm the fit and positioning of template 568 in disc space D1. Templates 568 of various heights having various sized bends 566 can be provided so the surgeon can perform multiple trials to obtain information as to the proper implant size.

[0120] Referring now to FIGS. 35 and 35(a), there is shown an implant insertion guide 600 according to another aspect of the present invention. Insertion guide 600 has a proximal portion that includes a first branch 602 pivotally joined to a second branch 604 by pin 606. Extending distally from pin 606 are distal portions 615 and 616 of branches 602 and 604, respectively. Distal portions 615 and 616 have a distal working end that includes guide members 608 and 610 extending from lateral offsets 609 and 611, respectively. Offset portions 609 and 611 have a straight portion extending generally parallel to and offset by distance d from axis 618, and a bend forming a first offset angle A2 with axis 618. Guide members 608 and 610 have an arcuate form extending from offset portions 609, 611 to the distal tip insertion guide 600. This shape generally corresponds to the shape of the implant insertion path P, as discussed below. Guide members 608, 610 preferably have a length and shape such that the distal tip of inserter guide 600 is positionable in the desired location in distal portion 37 of disc space D1. These offset portions 609, 611 laterally offset branches 602, 604 from guide members 608, 610. This provides room for placement of an implant insertion instrument, such as those described below, or the implant template inserter 560 described above, alongside branches 602, 604. The implant can be slid along guide members 608, 610 and into the disc space, and guide members 608, 610 provide a barrier that protects the anterior portion of the disc space during implant insertion.

[0121] In a preferred embodiment branches 602 and 604 of inserter guide 600 can be manipulated to separate guide portions 608, 610 and place guide portions 608, 610 in contact with the vertebral endplates. This contact allows the desired position of guide members 608, 610 to be maintained during implant insertion. Further, such separation capabilities might be required in order to further distract disc space D1 to facilitate implant insertion or removal. Inserter guide 600 includes a mechanism to force and/or maintain the separation of guide members 608 and 610. The spreading mechanism includes an externally threaded rod 612 joined to branch 602 and extending through hole 613 formed in the proximal end of branch 604. The spreading mechanism has an internally threaded hand nut 614 threadedly received on rod 612. Branches 602 and 604 may be forced together by action of internally threaded nut 614 on branch 604 forcing it towards branch 602, thereby forcing guide members 608 and 610 apart and into contact with the vertebral endplates.

[0122] Referring now to FIG. 36, there is shown a straight implant inserter 630. Inserter 630 includes a rigid hollow outer shaft 632 secured to a handle 634 at the proximal end of shaft 632. An inner shaft 636, either rigid or flexible, extends through outer shaft 632 and includes an implant connector 638 at its distal end extending distally from the distal end of outer shaft 632. Implant connector 638 is preferably threaded, but can include other attachment means

for engaging the implant. Inner shaft hand nut 642 is coupled to inner shaft 636, and can be rotated to in turn rotate connector 638 to secure or release the implant thereto as desired. A bearing member 640 is secured to outer shaft 636, and contacts the wall of implant to direct an insertion force to the implant.

[0123] Referring now to FIGS. 37-38, there is shown a curved inserter 650 and a pusher 670 adapted for use with the curved inserter 650 and other instruments of the present invention. Inserter 650 includes a rigid hollow outer shaft 652 secured to a handle 654 at the proximal end of shaft 652. Outer shaft 652 includes a bend 655 adjacent its distal end forming offset angle A3. A flexible inner shaft 656 extends through outer shaft 652 and bend 655. Inner shaft 656 includes an implant connector 658 at its distal end extending distally from the distal end of outer shaft 652. Implant connector 658 includes threads or other attachment means for engaging an implant. Inner shaft hand nut 662 is coupled to inner shaft 656, and can be rotated to in turn rotate connector 658 to secure or release the implant thereto as desired. A bearing member 660 is secured to outer shaft 656, and contacts the wall of the implant to direct the insertion force thereto. An impaction tool engaging portion 664 in the form of a notch formed around outer shaft 664 is provided in outer shaft 652.

[0124] An impaction tool or pusher 670 includes a shaft 672 having a bulb handle 674 secured to the proximal end of shaft 672. A shaft engaging portion 674 is secured to and extends from the distal end of shaft 672. In the illustrated embodiment, shaft engaging portion 674 is a U-shaped prong, and is positionable in notch 664 to apply a pushing force to curved inserter 650 to facilitate placement the implant secured to inserter 650 into distal portion 37 of disc space D1.

[0125] Insertion of implant I with curved inserter 650 is shown in FIG. 39. Implant I is attached to inserter 650, and implant I is then positioned in opening 35 with inserter 650 oriented such that it extends across spinous process S. As implant I is advanced from proximal portion 41 to distal portion 37 of disc space D1, inserter 650 is pivoted around spinous process S to the position indicated by inserter 650'. Pusher 670 can be used to facilitate insertion by allowing the surgeon to use pusher 670 to apply the insertion force with one hand while the other hand is used to pivot inserter 650.

[0126] An alternate embodiment implant insertion device is shown in FIGS. 40 through 44. The implant inserter 300 includes an inner guiding shaft 302 having a handle 308 attached to one end and a stop 306 disposed on the opposite end. Guiding shaft 302 includes a bend 304 adjacent the distal portion. Insertion sleeve 310 is slidably disposed about inner shaft 302. As previously described with respect to chisel 230, insertion sleeve 310 includes a drive portion 314 and impact shoulder 316 for use with a slap hammer, if necessary. Insertion sleeve 310 is connected at its distal end to an implant driver 318 by a flexible drive member 312. Implant driver 318 includes an arcuate cavity 322 having a substantially concave surface. The concave surface terminates adjacent the inner shaft 302.

[0127] As shown in FIGS. 42 through 43, an implant 330 is engaged to implant driver 318 with a portion of the implant positioned in arcuate cavity 322. Driver 318 urges implant 330 in the direction of arrow 320. It will be

understood that driver **318** and guide rod **302** cooperate to guide the implant along an arcuate path through the disc space formed by guide rod **302**. Implant **300** is one example of an implant that may be inserted with instruments according to the present invention. Further suitable implants are disclosed in U.S. Pat. No. 5,897,556 and also in PCT International Application PCT/US00/41392 entitled IMPACTED ORTHOPEDIC BONE SUPPORT IMPLANT, each of which is incorporated herein by reference in its entirety. The implant inserted with the instruments and techniques of the present invention could also be a spacer, a disc prosthesis or disc nucleus prosthesis.

[0128] As shown in FIG. 44, inner shaft **302** of implant inserter is positioned in disc space D1 with stop **306** positioned adjacent distal portion **37**. Implant **330** is positioned in opening **35** and implant driver **318** is urged forwardly along guide shaft **304** to drive the implant to distal portion **37** of disc space D1 as shown in FIG. 45. Once implant **330** is positioned in the desired location, bone ingrowth promoting material may be positioned around implant **330** using guide rod **302** as a guide for placement. Bone ingrowth promoting material **331** can also be placed in the interior portions of implant **330** prior to placement. Additionally, bone ingrowth promoting material **342** may be positioned in the anterior portion **39** of the disc space. As shown in FIG. 46, a second implant **349** may be placed in the proximal portion **41** of the disc space to complete a bilateral placement of implants to provide balanced structural support in disc space D1. Second implant **349** may also be filled with bone growth promoting material **351**.

[0129] While some of the above-described instruments illustrate a separate guide rod for each instrument, it is contemplated that a single guide rod may be positioned in the disc space and multiple instruments advanced over the guide rod to complete disc space preparation and implant insertion. Further, the stop on the guide rod may include selectively engageable portions that may be engaged with the vertebral endplates to maintain the position of the guide rod in the disc space.

[0130] In a further alternative embodiment implant shown in FIG. 47, the disc space is prepared using the any combination of instruments described above. The anterior portion **39** of the disc space may be packed with bone ingrowth promoting material **342**. A dual lobe implant **370**, which can have features such as those described below with respect to implant **1000**, is placed in the disc space D1 and has a length sufficient to span the disc space from the distal portion **37** to the proximal portion **41**. Implant **370** includes a first distal lobe **372** and a second proximal lobe **374**. A central opening **376** is provided that may be filled with bone ingrowth material. Implant **370** may be positioned by using any of the implant inserters described herein.

[0131] FIG. 48 illustrates one example another embodiment implant inserter according to the present invention. Implant inserter **400** includes an elongated shaft **402** with a handle **404** at its proximal end and an implant-gripping end at the opposite end. The implant-gripping end includes bifurcated branches **408** and **410** separated by a space **412**. The bifurcated branches each include a bend **406** to accommodate implant placement through opening **35** and into disc space D1. Branch **408** includes an inclined surface **414** and an implant engagement block **418**. Similarly, branch **410**

includes inclined surface **416** and an implant engagement block **420**. Each engagement block includes at least one projection (not shown) for insertion into a wall opening of implant **422** having a bearing surface to engage implant **422**. An outer sleeve **424** is slidably disposed on inner shaft **402** with an internal channel **426**. It will be understood that as sleeve **424** is advanced toward implant **422**, sleeve **424** will engage inclines **414** and **416** thereby urging branches **408** and **410** towards each other. The projections on engagement blocks **418** and **420** will then firmly engage implant **422**.

[0132] In a further embodiment illustrated in FIG. 49, implant inserter **450** has an implant engagement end **456** offset from shaft **452** by a bend **454**. A pusher **460** includes a handle **464** at one end and a projection (not shown) at the opposite end **462** for engagement with a corresponding opening (not shown) on shaft **452**. Pusher **460** provides a mechanism for the surgeon to use one hand to urge implant **458** across disc space D1, while the other hand of the surgeon pivots implant **458** with inserter **450** as it is moved across disc space D1. The longitudinal axis of pusher **460** is in relatively substantial alignment with the longitudinal axis of implant engagement end **456**. Thus, longitudinal force applied on pusher **460** may be directly transmitted as longitudinal force to advance implant **458** into the disc space.

[0133] Referring to FIGS. 50-51, an intradiscal rasp **700** according to the present invention is shown that is useful for disc space preparation with the approaches discussed herein. It is further contemplated that rasp **700** also has application with approaches and intradiscal procedures other than those discussed herein. Rasp **700** includes an elongated shaft **702** with a handle **704** on the proximal end of shaft **702** and a rasping head **705** on the distal end of shaft **702**. Shaft **702** has a distal portion **708** laterally offset from a proximal portion **706** to facilitate insertion of rasping head **705** into the disc space. Rasping head **705** is joined to and extends laterally from distal portion **708** and has a leading end wall **722** that is laterally offset from proximal portion **708** in the same direction as but to a greater extent than distal portion **708**. The configuration of shaft **702** also allows the surgeon to place rasping head **705** in contact with the vertebral endplates to prepare distal portion **37** of disc space D1 for implant insertion. Shaft **702** and rasping head **705** are configured in a manner that further allows preparation via a posterior lateral approach of at least a portion of the anterior third of the disc space for receipt of an implant. In order to match the endplate area prepared to the implant, rasping head **705** can have a size and shape, when viewed in the direction of the vertebral endplates, that generally corresponds to the size and shape of the implant to be inserted. In the illustrated embodiment, rasping head **705** has a generally banana or boomerang shape that generally corresponds to the shape of the vertebral endplate contacting surfaces of the implant **1000** discussed below. However, it should be understood that rasping head **705** can also be used for implants having other shapes, including circular, semi-circular, square, rectangular, or ovoid shapes, to name a few.

[0134] Further details regarding shaft **702** and rasping head **705** will now be discussed. Shaft **702** has proximal portion **706**, distal portion **708**, and an intermediate connecting portion **710** extending between and joining proximal portion **706** and distal portion **708**. Proximal portion **706** extends along a central axis **707**, distal portion **708** extends along a central axis **709**, and connecting portion **710** extends

along a central axis 711. Shaft 702 forms an angle A2 between central axis 707 and central axis 711, and an angle A22 between central axis 711 and central axis 709. Thus, connecting portion 710 laterally offsets distal portion 708 from proximal portion 706 a distance d. In one specific embodiment, this distance d is about 10 millimeters. Rasping head 705 extends from shaft 702 such that its leading end wall 722 is positioned even further laterally offset from proximal portion 706 than distal portion 708. This configuration allows shaft 702 to be initially positioned across spinous process S (such as shown with respect to inserter 1000 in FIG. 53) and then pivoted in the direction of arrow R away from spinous process S as rasping head 705 is inserted into disc space D1. Rasping head 705 can thus be used by the surgeon to create a rasped endplate portion on each vertebral endplate that generally corresponds to the implant insertion path.

[0135] As shown in FIG. 51, rasping head 705 includes a first rasping surface 712 and an opposite second rasping surface 714. Rasping head 705 further includes an anterior wall 718, a posterior wall 720, leading end wall 722 and a trailing end wall 724. Rasping head 705 is connected, mounted, integrally formed with, or otherwise attached to shaft 702 at trailing end wall 724. Each of these walls 718, 720, 722, and 724 has a smooth surface finish, and leading end wall 722 is rounded to provide a smooth transition between anterior wall 718 and posterior wall 720. Anterior wall 718 has a convex profile that, in addition to generally matching the shape of the anterior wall of implant 1000, also generally corresponds to the shape of the anterior inner annulus wall and can contact this annulus wall to limit insertion depth of rasping head 705. Posterior wall 720 has a slightly concave profile of less curvature than anterior wall 718, and posterior wall is shorter than anterior wall 718 between leading end 722 and trailing end 724. Posterior wall 724 generally corresponds to the shape of the posterior edge of the vertebral endplate.

[0136] In an alternate embodiment shown in FIGS. 50(a) and 51(a), rasp 700 has a rasping head 705' with a leading end wall 722' that is bulleted or tapered to facilitate entry of rasping head 705' into the disc space. This alternate embodiment further includes a rasping surface on the anterior wall 718' that can scrape material in the anterior portion of the disc space. First and second rasping surfaces 712', 714' can be used to rasp material from the vertebral endplates. In this embodiment, posterior wall 702', leading end wall 722' and trailing end wall 724' have a smooth surface finish.

[0137] Rasping surfaces of rasp 700 are provided with a surface configuration that allows that surgeon to scrape endplate material as the rasp is moved across the endplate. In one form, this rasping surfaces includes a plurality of pyramid-shaped teeth each having their upper most point positioned to contact the vertebral endplate. It is further contemplated that other rasping surfaces known to those skilled in the art could be provided, such as, for example, a plurality of frusto-conical projections, spikes, diamond-shaped projections, or wedge-shaped projections that each extend across the width of the rasping surface. Rasping surfaces 712, 714 can simultaneously contact the adjacent upper or lower vertebral endplates, or rasp 700 can be manipulated in the disc space to selectively contact one of the upper endplate or the lower endplate. In one specific embodiment, rasping head 705 has a height 716 between the

outermost ends of the rasping surfaces 712, 714 of 8 millimeters. In another specific embodiment, height 716 is 6 millimeters. However, it should be understood that other heights are also contemplated so long as rasping head 705 can be positioned in the intradiscal space.

[0138] Referring now to FIGS. 52-53, another embodiment implant and instrument set for inserting the implant into disc space D1 through opening 35 are provided. The instrument set includes an implant insertion tool in the form of inserter 1100, an impaction tool in the form of pusher 1200, and driver 1300. Inserter 1100 has a proximal portion with a shaft 1106 and a handle 1108 secured to the proximal end of shaft 1106. Shaft 1106 includes has a distal working end having a rotatable connecting portion 1102 with a threaded distal end portion 1104 for engaging a threaded opening on implant 1000. A male protrusion member 1105 extends from end portion 1104, and is positionable in a slot formed in implant 1000 as described further below. Driver 1300 is engageable to the proximal end of connecting portion 1102 to thereby rotate connecting portion 1102 to threadingly engage implant 1000 to threaded end portion 1104 of inserter 1100. Shaft 1106 further includes a lateral offset 1110 having a bend forming angle A2 with shaft 1106 and an angle A22 with distal shaft portion 1111, and is configured similar to the shaft of rasp 700 discussed above. Distal portion 1111 is thus offset from the proximal portion of shaft 1106 by distance d. In one specific embodiment, this offset distance is about 10 millimeters. This allows shaft 1106 to be initially positioned across spinous process S, as shown in FIG. 53, and then pivoted in the direction of arrow R away from spinous process S as implant 1000 is positioned in disc space D1. Pusher 1200 has a shaft 1202 and handle 1204 at the proximal end of shaft 1202. Pusher 1200 further includes a reduced diameter distal end portion 1206 positionable in an impaction tool engaging portion in the form of bore 1112 formed in shaft 1106.

[0139] The surgeon can use pusher 1200 to apply a pushing force to implant 1000 in the direction of arrow P while inserter 1100 is pivoted in the direction of arrow R to pivot the leading end of implant 1000 towards distal portion 37 of disc space D1. It should be understood that inserter 1100 does not pivot with respect to implant 1000, but rather inserter 1100 follows the proximal end of implant 1000 as the distal end of implant 1000 is pivoted to move implant 1000 non-linearly into and across the disc space along insertion path P. The inserter 1100 and pusher 1200 provide the surgeon the ability to use two-handed control to insert implant 1000 into the disc space along non-linear path P since the surgeon controls inserter 1100 with one hand while the other hand provides a pushing or impaction force on implant 1000 with pusher 1200.

[0140] Referring now to FIGS. 54-58, various views of implant 1000 are shown and will now be described in further detail. Implant 1000 is an interbody fusion device or cage that can be packed with bone growth material or other known substance and inserted into disc space D1 to promote bony fusion between vertebrae V1 and V2. Furthermore, the structural features of implant 1000 can have application for a disc prosthesis or a disc nucleus prosthesis that is to be inserted into disc space D1 through opening 35. Implant 1000 has a boomerang or banana shape that is suited for insertion to provide bilateral support in disc space D1 through a unilateral approach, after the disc space D1 has

been accessed and prepared using the above described instruments and techniques. It is also contemplated that disc space D1 can be accessed and prepared for implant insertion using any other known techniques and instruments and other approaches to the disc space, such as lateral, anterior or antero-lateral approaches, for inserting implant 1000. However, a particular problem exists providing bilateral support to the intradiscal space in instances where the disc space is accessed from a posterior lateral approach, such as a transforaminal approach, due to the difficulty in accessing and inserting the implant into distal portion 37 of disc space D1. Implant 1000 addresses this problem by providing a design that is suited for insertion into opening 35 and for subsequent pivotal movement and impaction movement through disc space D1 into distal portion 37.

[0141] Implant 1000 includes a concave posterior wall 1002 and an opposite convex anterior wall 1004. Implant 1000 further includes an arcuate leading end wall 1006 and an arcuate trailing end wall 1008. Each of the end walls 1006, 1008 extend between and connect posterior wall 1002 and anterior wall 1004, and provide a smooth transition therebetween to facilitate passage of implant 1000 through disc space D1. Implant 1000 further includes an upper bearing member 1010 and a lower bearing member 1012 extending between and connecting walls 1002, 1004, 1006 and 1008.

[0142] Implant 1000 has a height H1 at the medial portion of posterior wall 1002 and a second height H2 at the medial portion of anterior wall 1004. Upper bearing member 1010 and lower bearing member 1012 have a slight convexity between the anterior and posterior walls 1002, 1004 and height H2 is preferably greater than H1 in order to correspond to the anatomy of the vertebral endplates at the posterior portion of disc space D1. Leading end wall 1006 and trailing end wall 108 further have a height H3 that is less than H1 and H2, and upper bearing member 1010 and lower bearing member 1012 have a slight convexity between leading end 1006 and trailing end 1008 as best shown in FIG. 56. This double convexity preferably matches the double concavity of the adjacent vertebral endplate. Furthermore, the difference in heights between the upper and lower bearing members at the anterior and posterior walls can be provided so as to establish lordosis when implant 1000 is inserted in the disc space. Implant 1000 thus has application in restoring and maintaining spinal lordosis from a postero-lateral approach.

[0143] Upper bearing member 1010 can further be provided with a number of grooves 1014 and lower bearing member 1012 can be provided with a number of grooves 1016. Grooves 1014 and 1016 can engage the vertebral endplates to resist posterior and anterior migration of implant 1000 in the disc space.

[0144] In order to promote fusion, the walls and bearing members of implant 1000 are provided with a number of openings. Upper bearing member 1010 includes upper openings 1018a and 1018b separated by an upper strut 1019. Lower bearing member 1012 includes lower openings 1020a and 1020b separated by a lower strut 1021. An upper bar 1022 forming the perimeter of upper bearing member 1010 has a boomerang shape, and surrounds upper openings 1018a, 1018b and is connected to strut 1019. Similarly, a lower bar 1024 forming the perimeter of lower bearing

member 1012 has a boomerang shape, and surrounds lower openings 1020a, 1020b and is connected to strut 1021. Posterior wall 1002 includes a pair of posterior lateral openings 1026a and 1026b adjacent to the posterior side of leading end wall 1006 and trailing end wall 1008, respectively. Posterior vertical struts 1030a and 1030b extend between and are connected to upper bar 1022 and lower bar 1024 on the medial side of openings 1026a and 1026b, respectively. A posterior middle opening 1028 that is larger than posterior lateral openings 1026a, 1026b is defined between vertical struts 1030a, 1030b.

[0145] Anterior wall 1004 includes a pair of anterior lateral openings 1032b and 1032a adjacent to the anterior side of leading end wall 1006 and trailing end wall 1008, respectively. Anterior vertical struts 1034a and 1034b extend between and are connected to upper bar 1022 and lower bar 1024 on the medial side of openings 1032a and 1032b, respectively. An anterior middle opening 1036 that is larger than anterior lateral openings 1032a, 1032b is defined between vertical struts 1034a, 1034b. An offset strut 1038 is provided at the middle of opening 1036, and extends between and is connected with upper bar 1022 and lower bar 1024. Since offset strut 1038 is offset toward posterior wall 1002, and offset strut 1038 is also connected with upper strut 1019 and lower strut 1021. As best shown in FIG. 54, offset strut 1038 and middle opening 1036 provide upper member 1010 with an upper cantilevered portion 1040 and lower member 1012 with a lower cantilevered portion 1042. The cantilevered portions 1040, 1042 facilitate x-ray assessment of fusion in the middle of disc space D1 since there is no structural member blocking an x-ray image taken from a lateral view.

[0146] Implant 1000 is also provided with an inserter engaging portion 1048 at trailing end 1008 and an identical inserter engaging portion 1044 at leading end 1006 so that implant 1000 is insertable into disc space D1 from a unilateral approach taken on either side of the spinous process. Inserter engaging portions 1044, 1048 are preferably internally threaded and engageable with a distal end of an implant inserter, such as threaded end portion 1104 of inserter 1100 described above. A slot 1046 extends upwardly and downwardly from inserter engaging portion 1044 to upper bearing member 1010 and lower bearing member 1012. A slot 1050 extends upwardly and downwardly from inserter engaging portion 1048 to upper bearing member 1010 and lower bearing member 1012. Slots 1046, 1050 receive male member 1105 of inserter 1100 to prevent rotation of implant 1000 with respect to inserter 1100 when implant 1000 is engaged thereto. The cooperation between slots 1046, 1050 and male member 1105 also properly orients inserter 1100 with respect to implant 1000 when implant 1000 is engaged thereto.

[0147] Referring now specifically to FIG. 55, implant 1000 has an axis C extending through its center longitudinally. Axis C extends generally in the direction between the leading end and the trailing end of implant 1000, and is equal distance from the most posterior point A on leading end wall 1006 and the most posterior point B on trailing end wall 1008. Leading end wall 1006 is offset to the posterior side of axis C, and trailing end wall 1008 and engaging portions 1044, 1048 are also offset to the posterior side of axis C. The

offset in the leading end and trailing ends of implant **1000** facilitates the controlled insertion of implant **1000** along curved insertion path P.

[0148] One method for inserting implant **1000** will now be described with reference to FIGS. 52 and 53. Driver **1300** is used to connect implant **1000** to connecting portion **1104** of inserter **1100**. Distal end portion **1206** of pusher **1200** is positioned in bore **1112** in shaft **1106**. The leading end **1106** of implant **1100** is placed at the opening **35**. A manual or mechanical impaction force is applied to pusher **1200** to push implant **1000** a desired amount into proximal portion **41** of disc space D1. Inserter **1100** is pivoted in the direction of arrow R, thereby pivoting leading end **1106** in the disc in the posterior direction. Pusher **1200**, pivoted along with inserter **1200**, is then used to apply a further impaction force to push implant **1000** further into the disc space. However, due to the pivoting of inserter **1100** and pusher **1200**, the direction of insertion is now oriented more towards distal portion **37** of disc space D1. This alternating pivotal and pushing movement of implant **1000** is continued until implant **1000** is placed in the proper position in disc space D1.

[0149] Implant **1000** provides many further advantages. The shape and location of the bars, struts and walls positions the load bearing members at the strong bony surfaces of the vertebral endplates to provide maximum load support capacity and avoid implant subsidence into the vertebral endplates. The double convexity of the upper and lower bearing members in combination with the boomerang shape provides an intimate fit in the disc space and a profile that matches the concavity of the endplates, providing implant stability and promoting fusion. The openings and hollow interior maximize the volume available to receive bone growth material and also maximize the contact surface area between the bone growth material and the adjacent bony structure. Implant **1000** can be made from titanium, surgical grade stainless steel, or other bio-compatible material using fabricating techniques known in the art.

[0150] Referring now to FIGS. 59-64, there is shown another embodiment implant according to the present invention. Implant **1400** is an interbody fusion device or cage that can be packed with bone growth material or other known substance and inserted into disc space D1 to promote bony fusion between adjacent vertebrae V1 and V2. Implant **1400** has a boomerang or banana shape that is suited for insertion from a postero-lateral or uni-lateral approach into disc space D1, after the disc space D1 has been accessed and prepared using the above described instruments and techniques. Implant **1400** is insertable through opening **35** and pivotally moved and impacted through disc space D1 into distal portion **37**. It is also contemplated that disc space D1 can be accessed and prepared for implant insertion using any other known techniques and instruments and other approaches to the disc space, such as lateral, anterior or antero-lateral approaches, for insertion of implant **1400**.

[0151] Implant **1400** includes a body having a leading end portion **1450**, a trailing end portion **1452**, and a middle portion **1454** therebetween. A concave posterior wall **1402** and an opposite convex anterior wall **1404** extend along middle portion **1454**, and also along at least part of the corresponding side of leading end portion **1450** and trailing end portion **1452**. Implant **1400** further includes an arcuate

leading end wall **1406** extending along leading end portion **1450** between posterior wall **1402** and anterior wall **1404**. Implant **1400** also includes an arcuate trailing end wall **1408** extending along trailing end portion **1452** between posterior wall **1402** and anterior wall **1404**. Implant **1400** further includes an upper bearing surface **1410** and a lower bearing surface **1412** extending between walls **1402**, **1404**, **1406** and **1408**.

[0152] Implant **1400** has a height H1' at the medial portion of posterior wall **1402** and a second height H2' at the medial portion of anterior wall **1404**. Upper bearing surface **1410** and lower bearing surface **1412** have a slight convexity between the posterior and anterior walls **1402**, **1404**, and height H2' is greater than H1' in order to correspond to the anatomy of the vertebral endplates on each side of disc space D1. Leading end wall **1406** and trailing end wall **1408** each have a height H3' that is less than H1' and H2', and upper bearing surface **1410** and lower bearing surface **1412** have a slight convexity between leading end **1406** and trailing end **1408** as best shown in FIGS. 61-64. This double convexity substantially matches the double concavity of the adjacent vertebral endplates. Furthermore, the difference in heights between the upper and lower bearing surfaces at the anterior and posterior walls can be provided so as to establish lordosis when implant **1400** is inserted in the disc space. In one specific application, implant **1400** can be inserted from a postero-lateral approach to restore and maintain spinal lordosis.

[0153] Upper bearing surface **1410** can further be provided with a number of first grooves **1414a** along anterior wall **1404** and second grooves **1414b** along leading and trailing end walls **1406**, **1408**. Lower bearing surface **1412** can be provided with a number of grooves **1416a** along anterior wall **1404** and second grooves **1416b** along leading and trailing end walls **1406**, **1408**. Grooves **1414a**, **1414b** and **1416a**, **1416b** increase frictional resistance between the adjacent vertebral endplate and the bearing surfaces **1410**, **1412** to resist posterior and anterior migration of implant **1400** in the disc space.

[0154] In order to provide avenues for bone growth through implant **1400**, the walls of implant **1400** form a number of chambers opening at upper bearing surface **1410** and lower bearing surface **1412**. In particular, leading end portion **1450** includes first chamber **1418** and trailing end portion **1452** includes second chamber **1420**. Middle portion **1454** includes a middle chamber **1422**. A first strut **1424** is located between first chamber **1418** and third chamber **1422** and extends between posterior wall **1402** and anterior wall **1404**. A second strut **1426** is located between second chamber **1420** and third chamber **1422** and extends between posterior wall **1402** and anterior wall **1404**.

[0155] Posterior wall **1402** includes a posterior opening **1427** along middle portion **1454**, and anterior wall **1404** includes an anterior opening **1428** along middle portion **1454**. In the illustrated embodiment, posterior wall opening **1427** is circular and anterior wall opening **1428** is oval or racetrack shaped and elongated in the direction between upper bearing surface **1410** and lower bearing surface **1412**; however, other shapes for openings **1427**, **1428** are also contemplated. Leading end portion **1450** includes first and second wall openings **1430a**, **1430b** in anterior wall **1404**, and trailing end portion **1452** includes first and second wall

openings **1432a**, **1432b** in anterior wall **1404**. In the illustrated embodiment, openings **1430a**, **1430b** and **1432a**, **1432b** are oval or racetrack shaped and elongated in the direction between upper bearing surface **1410** and lower bearing surface **1412**; however, other shapes for openings **1430a**, **1430b** and **1432a**, **1432b** are also contemplated.

[0156] Anterior wall **1404** includes an offset portion **1434** that is offset anteriorly with respect to the remaining portions of anterior wall **1404** extending from either side thereof. Anterior offset portion **1434** provides additional support of the vertebrae and strength to the body of implant **1400**. A number of radiographic markers **1438** can also be provided in implant **1400** to facilitate X-ray assessment of the locating and positioning of implant **1400** in the patient's body. Such markers are particularly useful for an implant **1400** made from radiolucent material. In the illustrated embodiment, markers **1438** are provided at the midline of anterior wall **1404** at the anterior most point defined by offset portion **1434**. Markers **1438** are also provided at the posterior-most points of trailing end wall **1408** and leading end wall **1406**. Positioning markers **1438** at these locations provides an indication of the anterior and posterior placement of implant **1400** in the disc space, and also an indication of the lateral placement of implant **1400** in the disc space. Alignment of the end wall markers **1438** in a lateral X-ray indicates proper orientation of implant **1400** in the disc space in the A-P direction.

[0157] Implant **1400** includes a recessed area **1446** extending along leading end wall **1406** and a portion of anterior wall **1404**. Implant **1400** also includes a recessed area **1442** extending along trailing end wall **1408** and a portion of anterior wall **1404**. Recessed areas **1442**, **1446** are located in the respective wall portions mid-height between upper bearing surface **1410** and lower bearing surface **1412**. Recessed surfaces **1442**, **1446** are configured to receive a portion of an implant insertion instrument and to facilitate grasping of the implant, as discussed further below.

[0158] The symmetrical shape of implant **1400** allows implant **1400** to be inserted into disc space D1 from a unilateral approach taken on either side of the spinous process, and by grasping either of leading end portion **1450** or trailing end portion **1452** with an insertion instrument. Implant **1400** is provided with a first inserter instrument engaging receptacle **1448** at trailing end portion **1452** and a second inserter instrument engaging receptacle **1444** at leading end portion **1450**. Each of the engaging receptacles **1444**, **1448** are configured along with adjacent recessed area **1442**, **1446** for engagement with an implant inserter instrument, such as inserter instrument **1500** described below. Trailing end wall **1408** and leading end wall **1406** could also include a threaded hole for engagement with an inserter, such as inserter **1100** described above. In the illustrated embodiment, engaging receptacles **1444**, **1448** are in the form of grooves that extend between upper bearing surface **1410** and lower bearing surface **1412**. Each of the grooves is aligned with a corresponding one of the first strut **1424** and second strut **1426**. First strut **1424** and second strut **1426** provide bearing support to resist application of forces applied to the implant wall by an insertion instrument positioned in the respective engaging receptacle **1444**, **1448**.

[0159] Implant **1400** has an axis C1 extending through its center longitudinally. Axis C1 extends generally in the

direction between the leading end and the trailing end of implant **1400**, and is equal distance from the most posterior point on leading end wall **1406** and the most posterior point on trailing end wall **1408**. Leading end wall **1406** is offset to the posterior side of axis C1, and trailing end wall **1408** is offset to the posterior side of axis C1. The offset in the leading end and trailing ends of implant **1400** facilitates the controlled insertion of implant **1400** along curved insertion path P.

[0160] Referring now to FIGS. 65-69, there are shown instruments suited for inserting an implant through a postero-lateral opening in a spinal disc space. Inserter instrument **1500** provides the surgeon the ability to control insertion of an implant into the spinal disc space from a postero-lateral approach. Inserter instrument **1500** facilitates positioning of the implant in the disc space such that the implant extends across the disc space to provide bilateral support of the adjacent vertebrae. Inserter instrument **1500** also facilitates positioning of the implant in the disc space along a non-linear insertion path. Inserter instrument **1500** can also be used to position multiple implants at various locations in the disc space, and also for insertion of one or more implants from other approaches to the disc space.

[0161] Inserter instrument **1500** includes a proximal portion **1501** pivotally coupled to a distal portion **1512**. Proximal portion **1501** extends along axis **1520** when in a first position, and is pivotal relative to distal portion **1512** as indicated by proximal portion **1501'** and axis **1520'**. Proximal portion **1501** includes a handle **1502**. Handle **1502** is coupled to an outer shaft **1504** extending distally from handle **1502**. An inner shaft **1506** is slidably received in outer shaft **1504**. Inner shaft **1506** is spring biased distally with respect to handle **1502** to engage a distal portion **1512** of inserter instrument **1500**. An actuator **1508** is positioned around outer shaft **1504** and engaged to inner shaft **1506** with pin **1516** extending through a slot **1514** in outer shaft **1504**. For proximal portion **1501'**, inner shaft **1506** and spring **1508** are removed to show slot **1514'** though which pin **1516** extends. Actuator **1508** is moved proximally from a first engaged position to a disengaged position to push inner shaft **1506** against spring **1508**, disengaging inner shaft **1506** from distal portion **1512** and allowing proximal portion **1501** to be pivoted to the position indicated by proximal portion **1501'**.

[0162] Distal portion **1512** includes a shaft engaging portion **1522** extending along an axis **1524**. Distal portion **1512** further includes a distal implant engaging portion **1526** and a lateral offset portion **1528** extending between shaft engaging portion **1522** and implant engaging portion **1526**. Distal portion **1512** also includes a notched portion **1530** for engagement with a pusher instrument, such as pusher instrument **1580** shown in FIG. 65a.

[0163] Pusher instrument **1580** includes a handle **1582**, a shaft **1584** extending proximally from handle **1582**, and an inserter instrument engaging portion **1586** at a distal end of shaft **1584**. In the illustrated embodiment, inserter instrument engaging portion **1586** is a forked prong sized to be positioned around notched portion **1530** and to push against shaft engaging portion **1522**.

[0164] As shown in FIG. 66, shaft engaging portion **1522** includes a first receptacle **1522a** and a second receptacle **1522b**. Shaft engaging portion **1522** further includes a

through-hole 1522e to receive a pin to pivotally couple outer shaft 1504 thereto. Extending from first receptacle 1522a on one side of hole 1522e is a first surface 1522c, and extending from second receptacle 1522b on the other side of hole 1522e is a second surface 1522d. Receptacles 1522a and 1522b are configured to receive first and second extensions 1506a and 1506b, respectively, extending distally from inner shaft 1506. In the illustrated embodiment, receptacles 1522a, 1522b are tapered to facilitate sliding of extensions 1506a, 1506b therein between their engaged and disengaged positions.

[0165] When proximal portion 1501 is in its first position, second extension 1506b extends along second surface 1522d, and spring 1508 biases first extension 1506a into first receptacle 1522a. First receptacle 1522a engages first extension 1506a such that proximal portion 1501 cannot pivot relative to distal portion 1512. When actuator 1508 is pulled proximally, first extension 1506a is withdrawn proximally from first receptacle 1522a sufficiently so that proximal portion 1501 can be pivoted relative to distal portion 1512 to the position indicated by proximal portion 1501', wherein second extension 1506b is aligned with second receptacle 1522b. Actuator 1508 is released to spring bias second extension 1506b into second receptacle 1522b, and first extension 1506a extends along first surface 1522c. Second receptacle 1522b engages second extension 1506b to prevent movement of proximal portion 1501' relative to distal portion 1512 and lock proximal portion 1501' in the second position. Other embodiments contemplate that more than two positions are provided for proximal portion 1501.

[0166] In FIG. 65 inserter instrument 1500 is positioned adjacent vertebra V1 for insertion of an implant, such as implant 1400, into disc space D. When proximal portion 1501 is in its first position, as indicated by axis 1520 in FIG. 66, axis 1524 of shaft engaging portion 1522 extends toward vertebra V1 relative axis 1520. In the illustrated embodiment, axis 1524 forms angle B1 with axis 1520, and proximal portion 1501 is pivotal about an angle B2 between its first position indicated by axis 1520 and its second position indicated by axis 1520'. Lateral offset 1528 includes an axis 1529 that forms angle B3 with axis 1524, and implant engaging portion 1526 has a distal portion with axis 1527 forming angle B4 with lateral offset axis 1529. Implant 1400 has an axis C1 extending longitudinally therethrough that forms an angle B5 with distal implant engaging portion axis 1527. When implant 1400 is inserted in disc space D, axis C1 can be oriented substantially orthogonally to the sagittal plane of the spinal column.

[0167] In one specific embodiment, proximal portion 1501 moves between an angle B2 of 70 degrees between its first position along axis 1520 and its second position along axis 1520'. In this specific embodiment, shaft engaging portion 1522 extends from proximal portion 1501 at an angle B1 of or about 135 degrees. Lateral offset 1528 extends along axis 1529 forming an angle of or about 55 degrees. The distal portion of implant engaging portion 1526 extends along axis 1527 forming angle B4 of or about 65 degrees with lateral offset portion 1528. Axis C1 of implant 1400 forms an angle B5 of or about 65 degrees with axis 1527 of the distal portion of implant engaging portion 1526. Other embodiments of the insertion instrument contemplate other values for angles B1, B2, B3, B4 and B5.

[0168] Implant engaging portion 1526 includes a first member 1532 and a second member 1534 movably engaged to first member 1532. Second member 1534 has a first position along first member 1532, shown in FIG. 68, wherein a spinal implant such as implant 1400 is insertable between first and second members 1532, 1534. Second member 1534 is movable along first member 1532 to a second position wherein first member 1532 and second member 1534 engage implant 1400 therebetween.

[0169] First member 1532 includes a first arcuate finger 1532a at a distal end thereof and second member 1534 includes a second arcuate finger 1534a at a distal end thereof. With second member 1534 in its second position, first finger 1532a and second finger 1534a form an implant receptacle 1536 sized and shaped to receive a trailing end wall of an implant therein. In the illustrated embodiment, implant receptacle 1536 is sized and shaped to conform to the trailing end wall 1408 of implant 1400. Other embodiments contemplate that implant receptacle 1536 is sized and shaped to conform to the trailing ends of other sized and shaped implants.

[0170] Implant receptacle 1536 is defined by a first concave surface 1538 extending along the inner side of first finger 1532a of first member 1532 and a second concave surface 1540 extending along the inner side of second finger 1534a of second member 1534. First concave surface 1538 and second concave surface 1540 are oriented toward one another. First finger 1532a includes a projection 1541 extending from first concave surface 1538 toward second concave surface 1540. Projection 1541 is positionable in a hole or receptacle in implant 1400, such as hole 1432b. In the illustrated embodiment, first concave surface 1538 extends along the anterior wall of implant 1400, and second concave surface 1540 extends along a portion of the posterior wall of implant 1400. The curvature of first concave surface 1538 can be greater than that of second concave surface 1540 to accommodate the differences in curvature of the respective wall portions of the implant against which concave surfaces 1538, 1540 are positioned.

[0171] First finger 1532a can be configured to reside at least partially in recessed area 1442 extending along trailing end portion 1408 to minimize the protrusion of first finger 1532a into the adjacent anatomy and disc space during and after insertion of implant 1400. The height of finger 1532a can be less than the height of implant 1400 and correspond to the height of recessed area 1442 so as to not contact the vertebral endplates during insertion and to facilitate detachment of engaging portion 1526 from implant 1400. Second finger 1534a can have a height that is less than the height of implant 1400 so as to not contact the vertebral endplates during insertion and facilitate detachment of engaging portion 1526 from implant 1400.

[0172] A driving member 1542 is provided to move second member 1534 between its first and second positions. In the illustrated embodiment, driving member 1542 is in the form of an externally threaded cylindrical body rotatably captured in first member 1532. Driving member 1542 is threadingly engaged to an internally threaded passage 1544 extending along second member 1534. Driving member 1542 is accessible through opening 1546 for engagement with a driving tool (not shown.) In use, first finger 1532a is positioned in recess 1442 with projection 1541 in hole



**1432b.** The driving tool can be used to apply a force to rotate driving member **1542** in a first direction to move second member **1534** via threaded passage **1544**. Second finger **1534a** is moved toward implant **1400** until second finger **1534a** is firmly positioned in the groove formed at inserter instrument engaging receptacle **1448** of implant **1400**, thereby gripping implant **1400** in receptacle **1536** between fingers **1532a**, **1532b**.

[**0173**] There are further provided alignment instruments that extend from proximal portion **1501** to point toward an anatomical feature of the patient to provide an indication that the implant is properly positioned in disc space D. A first alignment instrument **1560** is removably engageable to the proximal end of handle **1502**. First alignment instrument **1560** includes a cup portion **1562** positionable over handle **1502**, and includes an extension member **1566** extending laterally to an alignment member **1564**. Extension member **1566** has a length between cup portion **1562** and alignment member **1564** sized for use with proximal portion **1501** in its first position. Alignment member **1564** extends toward the patient and is alignable with an anatomical portion of the patient to provide an indication that the implant is properly positioned in disc space D. In the illustrated embodiment, alignment member **1564** also extends toward a reference point on implant **1400**, such as the center of implant **1400** along its posterior and anterior walls. Thus, the anatomical feature to be aligned is positioned between the center of implant **1400** and the reference point on implant **1400**. In the illustrated embodiment, alignment member **1564** aligns with or points to spinous process SP of vertebra VI and also the center of implant **1400**. Alignment with other anatomical features of the patient is also contemplated.

[**0174**] A second alignment instrument **1570** is removably engageable to proximal portion **1501** in its second position. Second alignment instrument **1570** includes a cup portion **1572** positionable over handle **1502**, and includes an extension member **1576** extending laterally to an alignment member **1574**. Extension member **1576** has a length between cup portion **1572** and alignment member **1574** sized for use with proximal portion **1501** in its second position. Alignment member **1574** extends toward the patient and is alignable with an anatomical portion of the patient, such as spinous process SP, and also a reference point on implant **1400**, to provide an indication that the implant is properly positioned in disc space D.

[**0175**] One surgical procedure contemplated with inserter instrument **1500** includes engaging an implant, such as implant **1400**, to engaging portion **1526**. The disc space is accessed and prepared for postero-lateral insertion of the implant. Proximal portion **1501** is engaged in its first position along axis **1520** relative to distal portion **1512**. Inserter instrument **1500** is positioned with respect to the entry to disc space D such that leading end portion **1406** of implant **1400** is adjacent the disc space opening, and inserter instrument **1500** extends across the spinous process such as shown and discussed above with respect to instrument **1100**. Implant **1400** is inserted into disc space D by alternately and/or simultaneously pivoting inserter instrument **1500** about the spinous process SP, as indicated by arrow R and pushing implant **1400** into disc space D, as indicated by arrow P. When implant **1400** is properly positioned in disc space D, alignment instrument **1560** can be engaged, if not already so, to inserter instrument **1500**. Orientation of align-

ment member **1564** toward spinous process SP provides an indication of proper implant positioning in disc space D. Insertion of implant **1400** and its positioning in disc space D can also be confirmed radiographically or fluoroscopically. A pusher instrument, such as pusher instrument **1580**, can be engaged with notched portion **1530** to assist in application of the pushing force to push implant **1400** across disc space D to the desired position.

[**0176**] It is further contemplated that proximal portion **1501** can be pivoted to the position indicated by proximal portion **1501'** and axis **1520'**. Movement of proximal portion **1501** from the first position to the second position can be completed when implant **1400** is partially inserted, or prior to insertion of implant **1400**. It is further contemplated that proximal portion **1501** can be moved back and forth between the first and second positions during implant insertion. The second position of proximal portion **1501'** of inserter instrument **1500** facilitates application of a pushing force, with or without pushing instrument **1580**, to push implant **1400** across disc space D to the desired position with inserter instrument **1500**. When proximal portion **1501'** in its second position, alignment member **1574** of alignment instrument **1570** is oriented toward spinous process SP to provide an indication of proper implant positioning in disc space D.

[**0177**] Referring now to FIGS. 70 and 71, there is shown the proximal portion of another embodiment inserter instrument **1600** and alignment instrument **1670**. Except as otherwise discussed, inserter instrument **1600** can be substantially identical to inserter instrument **1500** discussed above. Inserter instrument **1600** includes a proximal portion **1601** movably engaged to a distal portion. Proximal portion **1601** includes a handle **1602** having a bore **1609** extending therein from the proximal end face of handle **1602**. Handle **1602** further includes a well **1603** formed therein in which a ball mechanism resides. The ball mechanism includes a spring **1605** and a ball **1607** movably captured in well **1603**.

[**0178**] Alignment instrument **1670** includes an alignment member **1674** and an extension member **1676** such as discussed above with respect to alignment instruments **1560**, **1570**. The engagement end of alignment instrument **1670** includes a rod portion **1672** positionable in bore **1603**. Rod portion **1672** includes a detent **1673** formed therein into which ball **1607** is removably engaged to secure alignment instrument **1670** to inserter instrument **1600**. It is contemplated that detent **1673** is positioned on rod portion **1672** such that alignment instrument **1670** is properly aligned with the implant engaged to the implant engaging portion of insertion instrument **1600** when ball **1607** is received in detent **1673**.

[**0179**] FIG. 72 is an enlarged section view shown an alternate connection arrangement between the proximal portion and the distal portion of the inserter instrument of FIG. 65. In FIG. 72 only a portion of proximal portion **1601** and distal portion **1612** are shown. Proximal portion **1601** includes an outer shaft **1604** and an inner shaft **1606** movably received therein. Outer shaft **1604** is pivotally engaged to distal portion **1612** via a pin through pin hole **1622d** of implant engaging portion **1612**. An actuator (not shown) is coupled to inner shaft **1606** to move it in outer shaft **1604** between an engaged position and a disengaged position with distal portion **1612**. Inner shaft **1606** is spring-biased distally and includes a distal extension **1606a** for

positioning in respective one of a first receptacle **1622a** when proximal portion **1601** in its first position and a second receptacle **1622b** when proximal portion **1601** is in its second position. A pusher instrument notch **1630** and a lateral extension **1628** of distal portion **1612** are also shown, it being understood these features and the remaining portion of distal portion **1612** can be similar to or identical to that provided with distal portion **1512** of inserter instrument **1500**.

[**0180**] In the illustrated embodiment, extension **1606a** is rectangular and is received in close fitting engagement in respective ones of the receptacles **1622a**, **1622b** to secure proximal portion **1601** in respective ones of the first and second positions. Outer shaft **1604** includes a distal end surface **1604a** that is curved along an arc defined by the pivot path of proximal portion **1601**. Distal end surface **1604a** moves along a correspondingly curved proximal end surface **1622c** of distal portion **1612**. Distal end surface **1604a** rides against proximal end surface **1622c** to provide a firm coupling arrangement between proximal portion **1601** and distal portion **1612** during movement of proximal portion **1601** and when proximal portion **1601** is in one of the first and second positions.

[**0181**] The implants described herein can be made from any biocompatible material, including synthetic or natural autograft, allograft or xenograft tissues, and can be resorbable or non-resorbable nature. Examples of tissue materials include hard tissues, connective tissues, demineralized bone matrix and combinations thereof. Further examples of resorbable materials are polylactide, polyglycolide, tyrosine-derived polycarbonate, polyanhydride, polyorthoester, polyphosphazene, calcium phosphate, hydroxyapatite, bioactive glass, and combinations thereof. Further examples of non-resorbable materials are non-reinforced polymers, carbon-reinforced polymer composites, PEEK and PEEK composites; shape-memory alloys; titanium and titanium alloys; cobalt chrome alloys; stainless steel; ceramics; and combinations thereof. Instruments described herein can be made from any suitable surgical grade material, including stainless steel, aluminum, plastics, and combinations of materials.

[**0182**] Any suitable osteogenetic material or composition is contemplated for placement within the chambers defined by the implants described herein. Such osteogenic material includes, for example, autograft, allograft, xenograft, demineralized bone, synthetic and natural bone graft substitutes, such as bioceramics and polymers, and osteoinductive factors. Where bony material is placed within the chambers of the implant, the material can be pre-packed into the hollow chambers before the device is implanted, or can be pushed through the wall openings after the device is in position in the spinal column. A separate carrier to hold the materials within the chambers of the device can also be used. These carriers can include collagen-based carriers, bioceramic materials, such as BIOGLASS®, hydroxyapatite and calcium phosphate compositions. The carrier material can be provided in the form of a sponge, a block, folded sheet, putty, paste, graft material or other suitable form. Moreover, the osteogenetic compositions contained within the implant can comprise an effective amount of a bone morphogenetic protein, transforming growth factor  $\beta 1$ , insulin-like growth factor 1, platelet-derived growth factor, fibroblast growth factor, LIM mineralization protein (LMP), and combinations

thereof or other therapeutic or infection resistant agent, held within a suitable carrier material.

[**0183**] The above-described instruments and methods have been disclosed with reference to use in substantially open surgical procedures. However, it is contemplated that the implants, instruments and methods may be utilized through guide sleeves or tubes to provide greater protection to adjacent tissues, to reduce the size of access incisions, to provide direct visualization of the surgical site, and/or to provide greater control of the method. The implants, instruments and methods may further be used in combination with disc space preparation and implant insertion through microscopic or endoscopic instruments that provide direct visualization of the surgical site, such as disclosed in U.S. patent application Ser. No. 09/692,932 entitled METHODS AND INSTRUMENTS FOR ENDOSCOPIC INTERBODY SURGICAL TECHNIQUES, filed Oct. 20, 2000, which is incorporated herein by reference in its entirety.

[**0184**] The instruments and methods have been disclosed with reference to a particular application for disc space preparation and implant insertion from a transforaminal approach to the spine. However, there are aspects of the inventions described herein that may be utilized or modified for use for a variety of surgical applications including, but not limited to, spinal surgery from a unilateral posterior approach, a lateral approach, an oblique approach, and through laparoscopic or endoscopic instruments from any of a variety of angles or approaches to the spine.

[**0185**] While the invention has been illustrated and described in detail in the drawings and the foregoing description, the same is considered to be illustrative and not restrictive in character. It is understood that only the preferred embodiments have been shown and described and that all changes and modifications that come within the spirit of the invention are desired to be protected.

What is claimed is:

1. An instrument for inserting a spinal implant, comprising:

a proximal portion including a handle and a shaft extending distally from said handle; and

an implant engaging portion at a distal end of said shaft, said implant engaging portion having a first member and a second member, said second member movable along said first member from a first position wherein said spinal implant is insertable between said first and second members to a second position wherein said first member and said second member engage the implant therebetween.

2. The instrument of claim 1, wherein in said second position said first and second members define an implant receptacle therebetween.

3. The instrument of claim 2, wherein said implant receptacle is defined by a first concave surface extending along an inner side of said first member and a second concave surface extending along an inner side of said second member, said first and second concave surfaces being oriented toward one another.

4. The instrument of claim 3, wherein said first member includes a projection extending from said first concave surface toward said second concave surface.

5. The instrument of claim 3, wherein said first concave surface has a first curvature and said second concave surface has a second concave curvature.

6. The instrument of claim 5, wherein said first concave curvature is different than said second concave curvature.

7. The instrument of claim 1, wherein said proximal portion is pivotal relative to said implant engaging portion.

8. The instrument of claim 1, wherein said first member and said second member are movably engaged along a distal shaft of said implant engaging portion.

9. The instrument of claim 7, wherein said first member includes a first finger extending distally from said distal shaft of said implant engaging portion and said second member includes a second finger extending distally from said distal shaft of said implant engaging portion, said first and second fingers defining an implant receptacle therebetween when said second member is in said second position.

10. The instrument of claim 1, wherein said shaft of said proximal portion includes an inner shaft movably positioned therein.

11. The instrument of claim 10, further comprising an actuator slidably positioned about said shaft and engaged to said inner shaft, said actuator being movable from a first position wherein said inner shaft engages said implant engaging portion to a second position wherein said inner shaft is disengaged from said implant engaging portion.

12. The instrument of claim 11, wherein with said actuator in said second position said proximal portion is pivotal relative to said implant engaging portion.

13. The instrument of claim 12, wherein:

with said actuator in said second position said proximal portion is pivotal between a first position and a second position; and

with said actuator in said first position said inner shaft engages said implant engaging portion to fix said proximal portion in one of said first position and said second position.

14. The instrument of claim 1, wherein said implant engaging portion includes a lateral offset portion extending in a first direction from a central axis of said proximal portion.

15. The instrument of claim 1, wherein:

said shaft includes an inner shaft movably positioned therein, said inner shaft including a first extension, a second extension and a slot between said first extension and said second extension; and

said implant engaging portion includes a shaft engaging portion at a proximal end thereof, said shaft engaging portion including a first receptacle engaging said first extension with said proximal portion in a first position relative to said implant engaging portion, said shaft engaging portion including a second receptacle engaging said second extension with said proximal portion pivoted to a second position relative to said implant engaging portion.

16. The instrument of claim 15, wherein said inner shaft is spring biased to engage said first extension and said second extension in one of said first receptacle and said second receptacle when said proximal portion is in a corresponding one of said first position and said second position.

17. The instrument of claim 16, further comprising an actuator slidably positioned about said shaft and coupled to

said inner shaft to move said inner shaft proximally to disengage said first extension and said second extension with respect ones of said first receptacle and said second receptacle.

18. The instrument of claim 1, further comprising an alignment instrument engageable to a proximal end of said proximal portion, said alignment instrument having an alignment member alignable with a portion of a patient's anatomy when the spinal implant is inserted to a desired position in the patient.

19. The instrument of claim 1, further comprising a driving member rotatably captured in said first member and engaged to said second member, said driving member rotatable to move said second member between said first position and said second position.

20. An instrument for inserting a spinal implant in a disc space, comprising:

a proximal portion including a handle and a shaft extending distally from said handle; and

an implant engaging portion at a distal end of said shaft, said implant engaging portion engageable to the spinal implant, said proximal portion engageable to said implant engaging portion in a first position for inserting the spinal implant in the disc space, said proximal portion movable relative to said implant engaging portion and engageable to said implant engaging portion in a second position for inserting the spinal implant in the disc space.

21. The instrument of claim 20, wherein said implant engaging portion includes a first member and a second member, said second member movable along said first member from a first position wherein said spinal implant is insertable between said first and second members to a second position wherein said first member and said second member engage the implant therebetween.

22. The instrument of claim 21, wherein in said second position said first and second members define an implant receptacle therebetween.

23. The instrument of claim 22, wherein said implant receptacle is defined by a first concave surface extending along an inner side of said first member and a second concave surface extending along an inner side of said second member, said first and second concave surfaces being oriented toward one another.

24. The instrument of claim 23, wherein said first member includes a projection extending from said first concave surface toward said second concave surface.

25. The instrument of claim 21, wherein said first member and said second member are movably engaged along a distal shaft of said implant engaging portion.

26. The instrument of claim 25, wherein said first member includes a first finger extending distally from said distal shaft and said second member includes a second finger extending distally from said distal shaft, said first and second fingers defining an implant receptacle therebetween when said second member is in said second position.

27. The instrument of claim 20, wherein said shaft of said proximal portion includes an inner shaft movably positioned therein.

28. The instrument of claim 27, further comprising an actuator slidably positioned about said shaft and engaged to said inner shaft, said actuator being movable from an engaged position wherein said inner shaft engages said

implant engaging portion to a disengaged position wherein said inner shaft is disengaged from said implant engaging portion.

**29.** The instrument of claim 28, wherein:

said shaft of said proximal portion is pivotally coupled to said implant engaging portion;

said inner shaft engages said implant engaging portion with said proximal portion in said first position;

said inner shaft is disengaged from said implant engaging portion with said actuator in said disengaged position and said proximal portion is pivotal to said second position; and

said actuator is movable to said engaged position to engage said inner shaft to said implant engaging portion with said proximal portion in said second position to fix said proximal portion in said second position.

**30.** The instrument of claim 20, wherein:

said shaft includes an inner shaft movably positioned therein, said inner shaft including a first extension, a second extension and a slot between said first extension and said second extension; and

said implant engaging portion including a shaft engaging portion, said shaft engaging portion including a first receptacle engaging said first extension with said proximal portion in said first position, said shaft engaging portion including a second receptacle engaging said second extension with said proximal portion in said second position.

**31.** The instrument of claim 30, wherein said inner shaft is spring biased to engage said first extension and said second extension with respective ones of said first receptacle and said second receptacle.

**32.** The instrument of claim 31, further comprising an actuator slidably position about said shaft and coupled to said inner shaft to move said inner shaft proximally to disengage said first extension and said second extension with respective ones of said first receptacle and said second receptacle.

**33.** The instrument of claim 20, further comprising an alignment instrument engageable to a proximal end of said proximal portion, said alignment instrument having an alignment member alignable with a portion of a patient's anatomy when the spinal implant is inserted to a desired position in the disc space.

**34.** An instrument for inserting a spinal implant in a disc space, comprising:

a proximal portion including a handle and shaft extending distally from said handle; and

an implant engaging portion at a distal end of said shaft, said implant engaging portion engageable to the spinal implant; and

an alignment instrument engageable to a proximal end of said proximal portion, said alignment instrument having an alignment member alignable with a portion of a patient's anatomy when the spinal implant is inserted to a desired position in the disc space.

**35.** The instrument of claim 34, wherein said alignment instrument includes an engagement end including a cup portion positionable over a proximal end of said handle.

**36.** The instrument of claim 34, wherein said alignment instrument includes an engagement end including a shaft engageable with a ball detent mechanism in said handle.

**37.** The instrument of claim 36, wherein said alignment member includes an extension member extending from said engagement end to said alignment member.

**38.** The instrument of claim 34, wherein said proximal portion has a first position and a second position relative to said implant engaging portion.

**39.** The instrument of claim 38, wherein said alignment instrument includes a second alignment instrument, each of said alignment instruments adapted for use with a corresponding one of said first position and said second position of said proximal portion.

**40.** The instrument of claim 34, wherein the portion of the patient anatomy is alignable between a predetermined location on the spinal implant and said alignment member.

**41.** A spinal implant insertable in a spinal disc space, the implant comprising a body including:

a middle portion having opposite first and second ends;

a leading end portion extending from said first end of said middle portion;

a trailing end portion extending from said second end of said middle portion;

an upper surface and an opposite lower surface along said middle portion and said leading end portion and said trailing end portion; and

an inserter instrument engaging receptacle at a junction of said middle portion and said trailing end portion.

**42.** The implant of claim 41, wherein said receptacle is a groove formed in a posterior wall of said body, said groove extending between said upper surface and said lower surface.

**43.** The implant of claim 41, further comprising an inserter instrument engaging receptacle at a junction of said middle portion and said leading end portion.

**44.** The implant of claim 41, wherein said body includes an anterior wall and a posterior wall each extending along a respective side of said middle portion, said leading end portion and said trailing end portion.

**45.** The implant of claim 44, wherein said anterior wall has a generally convex profile and said posterior wall has a generally concave profile.

**46.** The implant of claim 44, wherein said anterior wall includes a recessed area extending along said trailing end portion.

**47.** The implant of claim 46, wherein said anterior wall includes a second recessed area extending along said leading end portion.

**48.** The implant of claim 44, wherein said posterior wall has a height that is less than a height of said anterior end wall.

**49.** The implant of claim 41, wherein said leading end portion and said trailing end portion each define a chamber extending between said upper surface and said lower surface.

**50.** The implant of claim 49, wherein said middle portion defines a chamber extending between said upper surface and said lower surface.

- 51.** The implant of claim 50, further comprising:
- a first strut between said chamber of said leading end portion and said chamber of said middle portion; and
  - a second strut between said chamber of said trailing end portion and said chamber of said middle portion.
- 52.** The implant of claim 51, wherein said inserter instrument engaging receptacle is formed at the junction of said second strut and a posterior wall of said body.
- 53.** The implant of claim 41, wherein said body is comprised of non-resorbable material selected from the group consisting of: non-reinforced polymers, carbon-reinforced polymer composites, PEEK, PEEK composites, shape-memory alloys, titanium, titanium alloys, cobalt chrome alloys, stainless steel, ceramics and combinations thereof.
- 54.** The implant of claim 41, wherein said body is comprised of PEEK material.
- 55.** The implant of claim 54, further comprising at least one radiographic marker in said body.
- 56.** The implant of claim 41, wherein said body includes at least one chamber.
- 57.** The implant of claim 41, further comprising bone growth material in said at least one chamber.
- 58.** The implant of claim 57, wherein said bone growth material includes one or more selected from group consisting of: bone morphogenetic protein, transforming growth factor, insulin-like growth factor, platelet-derived growth factor, fibroblast growth factor, and LIM mineralization protein (LIP).
- 59.** A spinal implant insertable in a spinal disc space, the implant comprising a body having:
- a leading end wall;
  - a trailing end wall;
  - a posterior wall extending between said leading end wall and said trailing end wall; and
  - an anterior wall extending between said leading end wall and said trailing end wall, wherein said anterior wall includes a middle portion, a trailing end portion, and a leading end portion, said middle portion being offset anteriorly from said leading end portion and said trailing end portion.
- 60.** The implant of claim 59, further comprising:
- an upper bearing surface extending between said leading end wall, said anterior wall, said posterior wall and said trailing end wall; and
  - an opposite lower bearing surface extending between said leading end wall, said anterior wall, said posterior wall and said trailing end wall.
- 61.** The implant of claim 59, wherein:
- said posterior wall includes a middle portion, a leading end portion, and a trailing end portion; and
  - said posterior wall includes an inserter instrument engaging receptacle at a junction of said middle portion and said trailing end portion thereof.
- 62.** The implant of claim 61, wherein said receptacle is a groove extending said upper surface and said lower surface.
- 63.** The implant of claim 61, wherein said posterior wall includes an inserter instrument engaging receptacle at a junction of said middle portion and said leading end portion thereof.
- 64.** The implant of claim 59, wherein said anterior wall has a generally convex profile and said posterior wall has a generally concave profile.
- 65.** The implant of claim 59, wherein said anterior wall includes a first recessed area extending along said leading end portion thereof and a second recessed area extending along said trailing end portion thereof.
- 66.** The implant of claim 59, wherein said posterior wall has a height that is less than a height of said anterior end wall.
- 67.** The implant of claim 59, further comprising a first chamber between a leading end portion of said posterior wall and said leading end portion of said anterior wall and a second chamber between a trailing end portion of said posterior wall and said trailing end portion of said anterior wall.
- 68.** The implant of claim 67, further comprising a third chamber between a middle portion of said posterior wall and said middle portion of said anterior wall.
- 69.** The implant of claim 68, further comprising:
- a first strut extending from said anterior wall to said posterior wall between said first chamber and said third chamber; and
  - a second strut extending from said anterior wall to said posterior wall between said second chamber and said third chamber.
- 70.** The implant of claim 69, further comprising an inserter instrument engaging receptacle in said posterior wall at the junction of said second strut and said posterior wall.
- 71.** The implant of claim 70, further comprising a second inserter instrument engaging receptacle in said posterior wall formed at the junction of said first strut and said posterior wall.
- 72.** A spinal implant insertable in a spinal disc space, the implant comprising a body including:
- a leading end wall;
  - a trailing end wall;
  - a posterior wall extending between said leading end wall and said trailing end wall;
  - an anterior wall extending between said leading end wall and said trailing end wall;
  - a first strut adjacent said leading end wall extending from said anterior wall to said posterior wall;
  - a second strut adjacent said trailing end wall extending from said anterior wall to said posterior wall;
  - a chamber formed by said first strut, said second strut, said anterior wall and said posterior wall; and
  - an inserter instrument engaging receptacle at the junction of said second strut and said posterior wall.
- 73.** The implant of claim 72, further comprising:
- a second chamber formed by said first strut, said leading end wall, said anterior wall and said posterior wall; and

a third chamber formed by said second strut, said trailing end wall, said anterior wall and said posterior wall forming a second chamber.

**74.** The implant of claim 72, wherein said anterior wall includes a middle portion, a trailing end portion, and a leading end portion, said middle portion being offset anteriorly from said leading end portion and said trailing end portion.

**75.** The implant of claim 72, further comprising an inserter instrument engaging receptacle at the junction of said first strut and said posterior wall.

**76.** A kit, comprising:

an implant insertable in a spinal disc space, said implant having a leading end portion, a trailing end portion, and a middle portion therebetween;

an inserter instrument comprising:

a proximal portion including a handle and a shaft extending distally from said handle, said proximal portion extending along a central axis;

an implant engaging portion at a distal end of said shaft, said implant engaging portion configured to engage said trailing end portion of said implant such that said leading end portion of said implant extends away from the central axis of said proximal portion.

**77.** The kit of claim 76, wherein said implant engaging portion is laterally offset from the central axis of said shaft.

**78.** The kit of claim 76, wherein said proximal portion is pivotally engaged to said implant engaging portion and movable between a first implant insertion position and a second implant insertion position relative to said implant engaging portion.

**79.** The kit of claim 76, further comprising a pusher instrument engageable with said inserter instrument to provide a pushing force to said implant through said inserter instrument.

**80.** The kit of claim 76, further comprising an alignment instrument engageable to said inserter instrument, said alignment instrument having an alignment member alignable with a portion of a patient's anatomy when said spinal implant is inserted to a desired position in the spinal disc space.

**81.** The kit of claim **80**, wherein the portion of the patient anatomy is alignable between a predetermined location on the spinal implant and said alignment member.

**82.** A method for inserting an implant in a spinal disc space of a patient, comprising:

accessing the spinal disc space;

preparing the spinal disc space for insertion of the implant;

engaging the implant to an inserter instrument in a first position relative to a proximal portion of the inserter instrument, the proximal portion being movable relative to the implant to a second position;

selecting one of the first position and the second position; and

inserting the implant in the spinal disc space with the proximal portion of the inserter instrument in the selected position.

**83.** The method of claim **82**, further comprising:

moving the proximal portion of the inserter instrument to the other of the first position and the second position during insertion of the implant.

**84.** The method of claim **82**, wherein selecting one of the first position and the second position includes pivoting the proximal portion of the inserter instrument relative to a distal implant engaging portion of the inserter instrument.

**85.** The method of claim **82**, further comprising applying a pushing force to the inserter instrument during insertion of the implant in the spinal disc space.

**86.** The method of claim **82**, further comprising:

engaging an alignment instrument with the inserter instrument; and

inserting the implant in the spinal disc space so that the alignment instrument aligns with an anatomical feature of the patient.

\* \* \* \* \*