

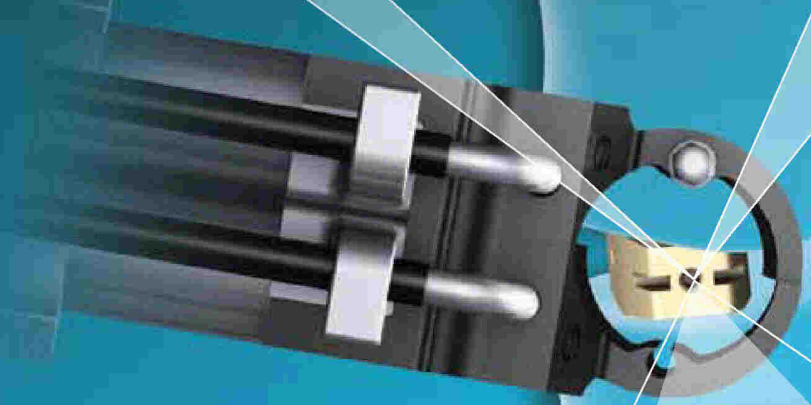

# DIRECT LATERAL

Interbody Fusion

## DLIF Surgical Technique



NUVA0000014

**ACCESS**  
MAST QUADRANT™ DL  
Retractor System

- » Illuminated surgical access with minimal soft tissue disruption
- » Vertebral body stabilization pins to prevent retractor migration

**INTERBODY**  
CLYDESDALE® Spinal System

- » Bullet nosed tip to aid in distraction
- » Convex design to contact vertebral body end plates

The Direct Lateral Interbody Fusion procedure provides spine surgeons with a complete minimally invasive solution for the treatment of degenerative lumbar conditions. By utilizing a direct lateral approach to the spine, this procedure enables placement of a large interbody graft into the disc space for anterior column support while avoiding the obstacles associated with traditional anterior or posterior approaches. The DLIF procedure incorporates a comprehensive set of instruments and implants including fully integrated neuromonitoring, streamlined access instrumentation, anatomically designed implants and percutaneous fixation systems.



**NEUROMONITORING**  
NIM-ECLIPSE®  
Spinal System\*

- » Advanced surgeon directed and neurophysiologist supported neuromonitoring.
- » Accurate and immediate warning of potential harm to nerves with real time nerve proximity detection.

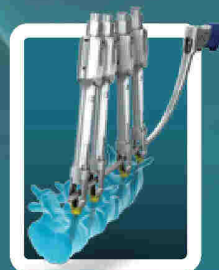

**FIXATION**  
CD HORIZON® SEXTANT® II Percutaneous Rod Insertion System and CD HORIZON® LONGITUDE® Multi-level Fixation System

- » Reproducible percutaneous rod and screw implantation.
- » Minimally invasive fixation for complex spine procedures.





# DIRECT LATERAL

Interbody Fusion

## Transpsoas Approach DLIF Surgical Technique

Instrument Set	2
Preoperative Planning	7
NIM-ECLIPSE® Spinal System Needle Electrode Placement	8
Patient Positioning	10
Localization	12
Dissection to the Psoas	13
Neuromonitoring Through the Psoas	14
Dilation	16
Retractor Placement	16
Disc Preparation	19
Trialing	23
Implant Placement	24
Closure	25
Explantation	26
Fixation	27
Product Ordering Information	28
Important Product Information	30

## Instrument Set

### Retractor/Access Instruments

---



**Retractor Blades**  
9cm Left, Right (9567309, 9567319)  
10cm Left, Right (9567300, 9567310)  
11cm Left, Right (9567301, 9567311)  
12cm Left, Right (9567302, 9567312)  
13cm Left, Right (9567303, 9567313)  
15cm Left, Right (9567305, 9567315)



**Rotating Flex Arm Attachment**  
(9568010)



**Stability Pin Driver**  
(8970400)



**Stability Pins**  
9cm (9569309)  
10cm (9569310)  
11cm (9569311)  
12cm (9569312)  
13cm (9569313)  
15cm (9569315)

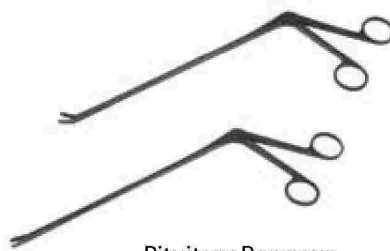

**Pituitary Rongeur**  
Up (2940076)  
Straight (2940075)



**Rotate Kerrison Punch**  
3mm (2940068)  
5mm (2940069)



**Guidewire-Trocar Tip**  
Short (8670005)  
Long (8670002)



**5.3cm Dilator**  
(9560420)



**10.6cm Dilator**  
(9561421)



**16.0cm Dilator**  
(9561422)



**20.8cm Grooved Dilator**  
(9561424)



**Direct Lateral Retractor**  
(9569000)

## Instrument Set *continued*

### Disposables

---



**NIM® X-PAK Probe**  
(9450069)

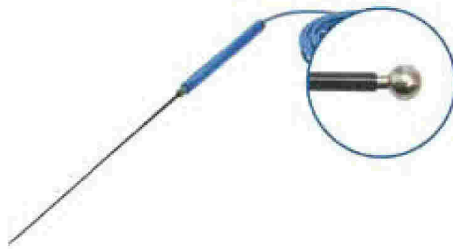

**NIM-SPINE® 23cm Ball-tip Probe**  
(9450015)



**Bayoneted Dissectomy Knife**  
(9560659)



**MAST QUADRANT™ Illumination System** (9560658)

### Flexible Arm

---



**Flexible Arm**  
(9561524)



**Bed Rail Clamp**  
(9561523)

## Instrument Set *continued*

### Disc Preparation Instruments

---



Combo Tool  
(2940050)



Angled Combo Tool  
(2940051)



Reverse Angle  
Combo Tool  
(2940052)



Straight Serrated  
Cup Curette  
(2940053)



Angled Serrated  
Cup Curette  
(2940054)



Long Suction  
(2940200)



Reverse Angle  
Serrated Cup Curette  
(2940055)



Straight Ring Curette  
(2940056)



10mm Cobb Elevator  
(2940057)



18mm Cobb Elevator  
(2940059)



Shavers, 45mm length  
8mm (2941608) **Green**  
10mm (2941610) **Blue**  
12mm (2941612) **Yellow**  
14mm (2941614) **Brown**  
16mm (2941616) **Purple**



Cannulated Reamer T-Handle  
(2900165)

## Instrument Set *continued*

### Disc Preparation Instruments *continued*

---



Wide Nerve Root Retractor, Long  
(9561554)



6/8mm Distractor  
(2940186)

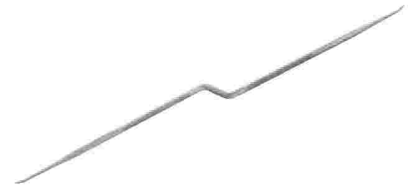

Bayoneted Penfield 4  
(9569650)

### Implant Instruments

---



8mm Trial/Distractor  
45mm (2986845) I  
50mm (2986850) II  
55mm (2986855) III



Threaded Inserter  
(2982001)



Removal Tool  
(2982002)

10mm Trial/Distractor  
45mm (2986045) I  
50mm (2986050) II  
55mm (2986055) III



Slap Hammer  
(9074002)

12mm Trial/Distractor  
45mm (2986245) I  
50mm (2986250) II  
55mm (2986255) III

14mm Trial/Distractor  
45mm (2986445) I  
50mm (2986450) II  
55mm (2986455) III

16mm Trial/Distractor  
45mm (2986645) I  
50mm (2986650) II  
55mm (2986655) III

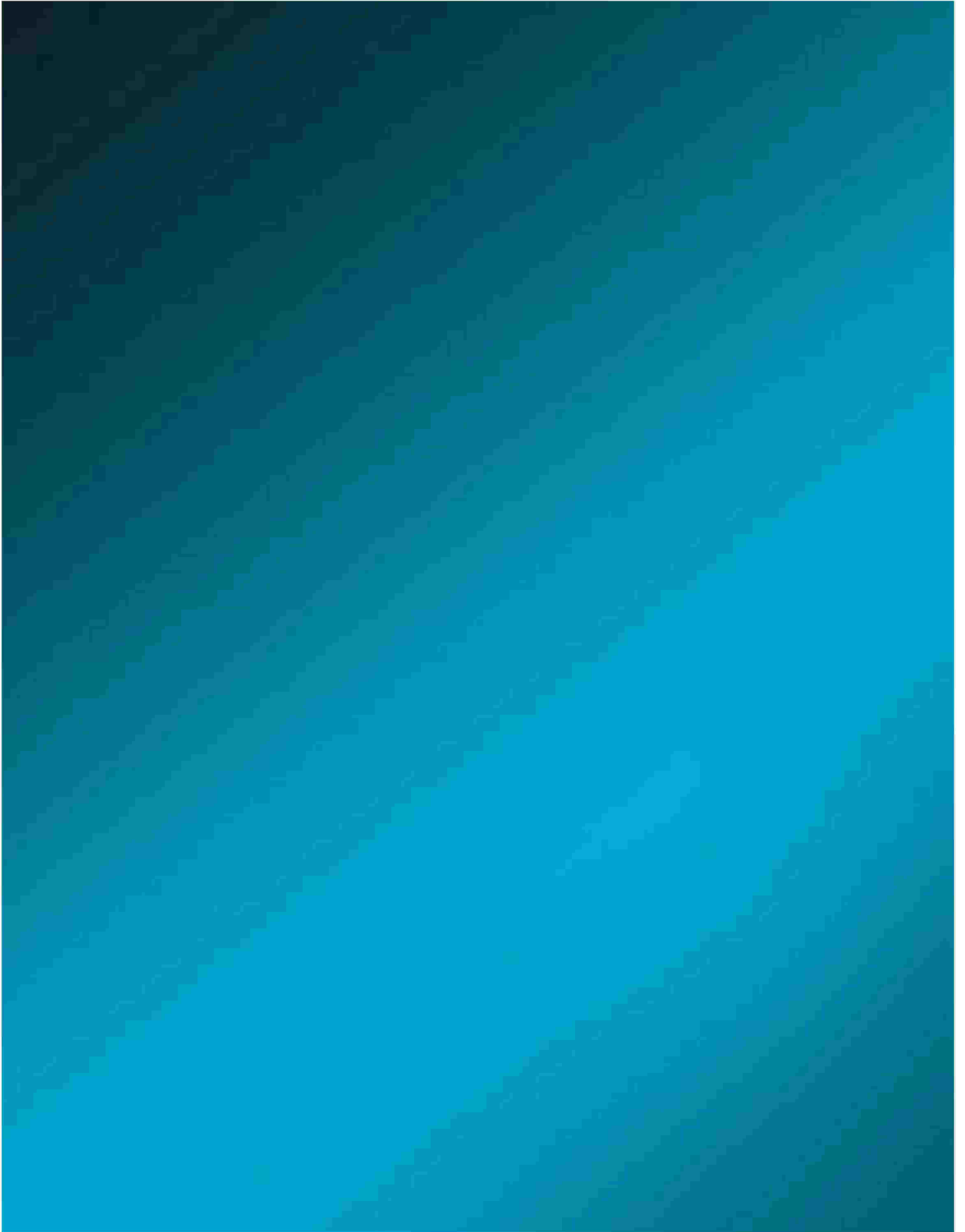

NUVA0000021



## Preoperative Planning

Preoperative planning can be useful in determining:

- » Location of the iliac crest and lower ribs in relation to disc space of interest (**Figure 1**)
- » Position of the anterior vasculature and posterior nerve structures via axial MRI
- » Curvature of the spine (**Figure 2**)

Although infrequent, a few patients may have a deep-seated L4–L5 disc space that could be difficult to reach via a direct lateral approach, even if table breaking options are employed. Obtaining standing anterior-posterior x-ray images with the patient bending laterally can help determine whether or not a level can be accessed above the iliac crest.

Standard lateral surgical positioning is right lateral decubitus, or left side up, however the surgeon should consider ease of access and surgeon preference in determining which side to approach. Correction can be achieved equally from either the convex or concave side of the curve. However, approaching from the concave side allows the skin incision to be minimized in some cases.



Figure 1

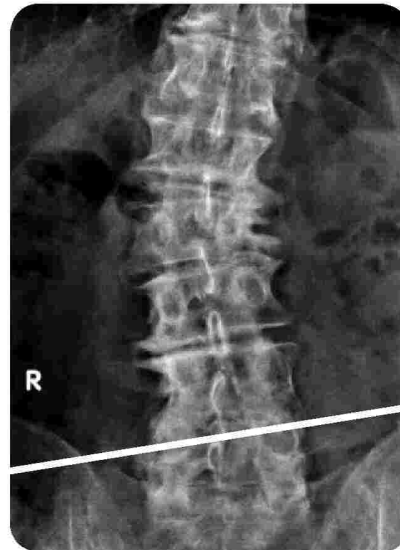

Figure 2

## NIM-ECLIPSE® Spinal System Needle Electrode Placement

After the patient is asleep, needle recording electrodes are placed in the innervated muscles in the legs to monitor the affected nerve roots during the procedure. Please follow the instructions below, as well as the accompanying electrode placement guide, to correctly place the electrodes in the appropriate muscles for the desired levels.

1. Electrodes are placed prior to patient draping and the establishment of the sterile field.
2. Clean the areas with alcohol wipes.
3. The green lead ground electrode should be placed between the stimulator and the monitoring electrodes in a location where the bone is close to the skin and the electrode will not contact muscle.
4. The white stimulus return electrode should be placed near the location of stimulation. Connect the Probe lead wire to the instrument jack of the patient interface module.
5. Tape all of the electrodes securely in place and plug the leads into the patient interface box and turn on the NIM-ECLIPSE® Spinal System to begin monitoring.

Active: needle inserted four to five fingerbreadths (fb) below the pubic tubercle and deeply into the palpable muscle belly.

Reference: needle inserted subcutaneously above the active needle.

- Channel 1** Left L2 – L3 AL
- Channel 5** Right L2 – L3 AL

Active: insert needle tangentially but deep into muscle belly one handbreadth above the patella.

Reference: insert needle subcutaneously at patellar tendon.

- Channel 2** Left L2 – L4 VL
- Channel 6** Right L2 – L4 VL

**Helpful Tip**

*Let the anesthesiologist know EMG monitoring will be used during the procedure to ensure that no neuromuscular blocking agents are administered during monitoring. During intubation, a fast-acting neuromuscular blocking agent should be used.*

Sample L2-L5 Set-up

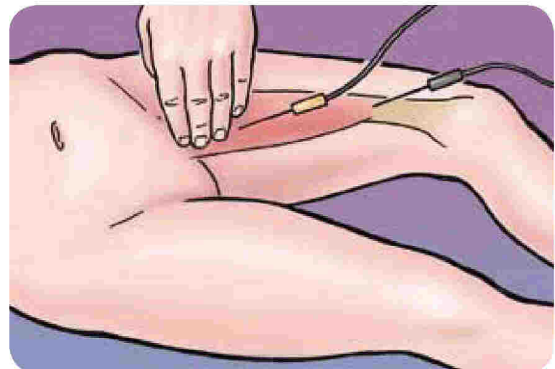

Adductor Longus (AL)

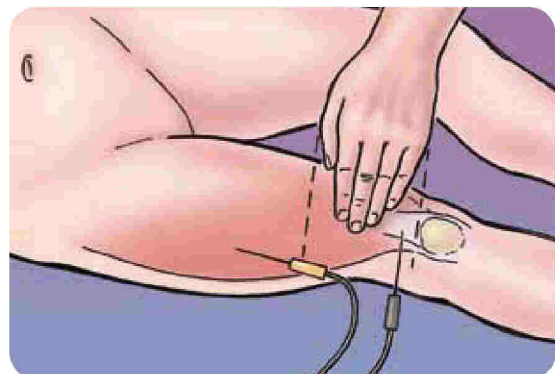

Vastus Lateralis (VL)

## NIM-ECLIPSE® Spinal System Needle Electrode Placement *continued*

Active: insert needle into muscle belly three fb above the midpoint of the bi-malleolar line (lateral to the tibial crest).

Reference: insert needle over the tibial crest (chin).

Channel 3 Left L5 EHL

Channel 7 Right L5 EHL

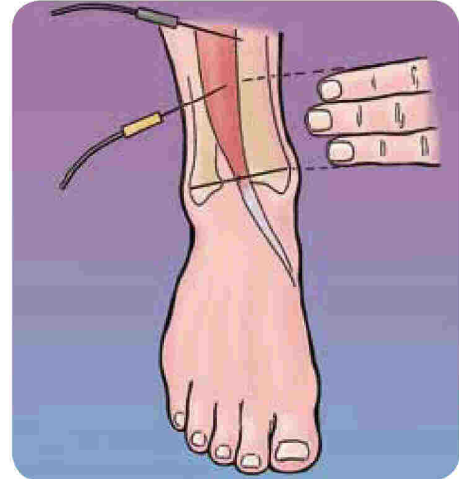

*Extensor Hallucis Longus (EHL)*

Active: insert needle into the muscle belly one handbreadth below the posterior crease of the knee.

Reference: insert needle subcutaneously 2cm to 3cm away from the active electrode.

Channel 4 Left S1 – S2 GASTROC

Channel 8 Right S1 – S2 GASTROC

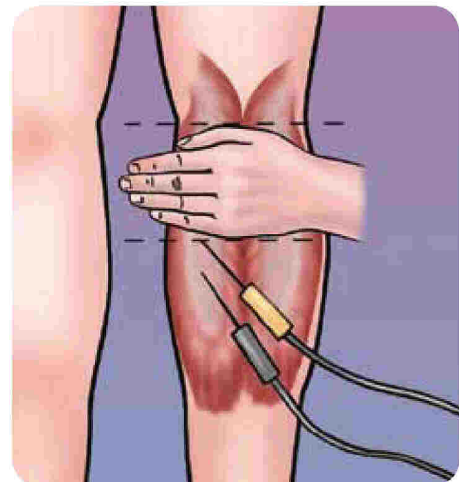

*Medial Gastrocnemius (GASTROC)*

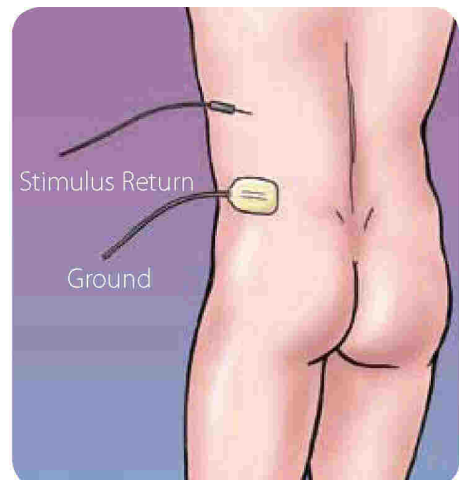

*Ground/Stimulus Return*

NUVA0000024

## Patient Positioning

The patient is placed in the lateral decubitus position and should be positioned so that the top of the iliac crest is in line with the break of the radiolucent surgical table. An axillary roll is placed to protect the neurovascular structures in the axilla. Padding is placed between the arms to ensure they remain suspended in the neutral position. The top leg of the patient should be flexed in order to relax the psoas muscle and prevent spreading of the nerves across the psoas. Padding is also placed beneath and in between the legs from the knees distally (**Figure 3**).

The patient is secured to the surgical table with tape at four locations (**Figure 4**):

1. Just beneath the iliac crest
2. Over the thoracic region, just beneath the shoulder
3. From the back of the table, over the ankle, and past the knee to the front of the table
4. From the shin to the back of the table

Starting in a reverse trendelenburg position, the head of the table is dropped and a slight flexion is applied to the surgical table. This technique allows for better access to the lumbar spine by increasing the distance between the iliac crest and lower rib as well as by opening up the disc to be entered.

### ✓ Helpful Tip

*For certain tables, the bed must be set up in the reverse position to ensure that the C-arm has adequate room to maneuver under the break of the table.*

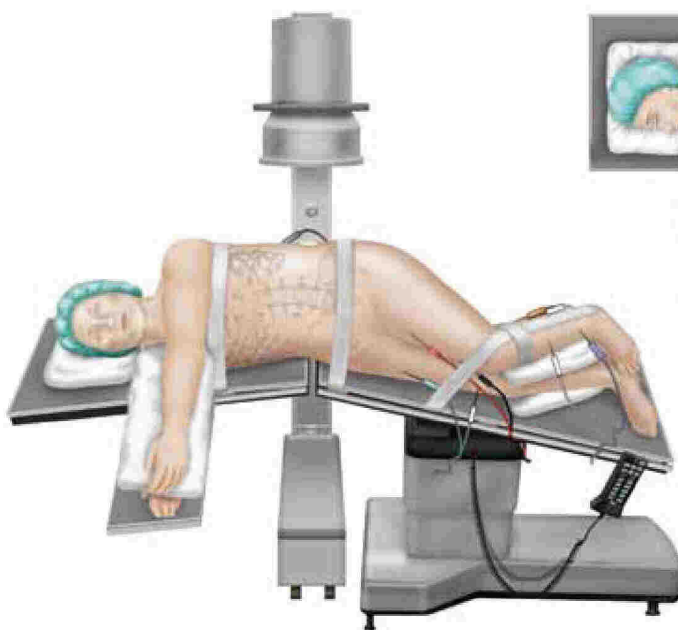

Figure 3

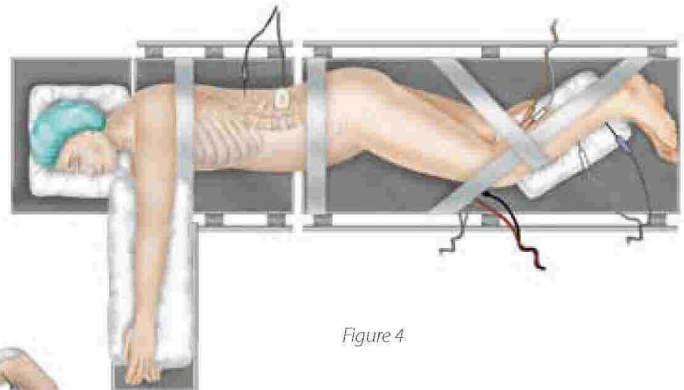

Figure 4

## Patient Positioning *continued*

First, a true AP image should be obtained to ensure the patient is positioned in a true lateral position. On the AP x-ray, clear, distinct pedicles that are equidistant from the spinous process should be visible. (Figure 5). Then a lateral x-ray is obtained and clean, distinct end plates should be seen (Figure 6).

### ! Important

*It is critical the C-arm remain in the 0 and 90 degree positions at all times to ensure a safe lateral working channel across the disc space. For multi level cases, rotate the surgical table independent of the C-arm for each level to re-obtain true images.*



Figure 5



Figure 6

## Localization

Fluoroscopy is used to confirm the target segment and mark the location for the initial incision. For a single-level case the patient should be marked over the midsection of the target disc and an approximately 3cm horizontal, vertical or oblique incision can be made (**Figure 7**). For a two-level case, the patient should be marked over the midsection of the intervening vertebral body (**Figure 8**).

### ✓ Helpful Tip

*It may be possible to access multiple levels through one vertical skin incision, depending on the anatomy and curvature of the spine. Although a single incision may be used to reach multiple levels, the surgeon must perform separate dilations through the psoas for each operative disc space.*

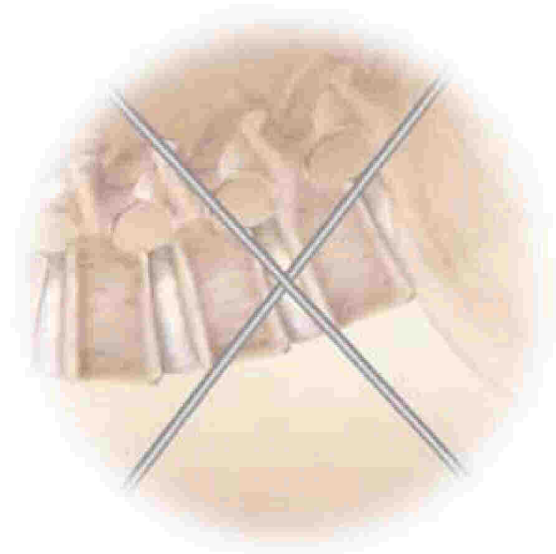

Figure 7

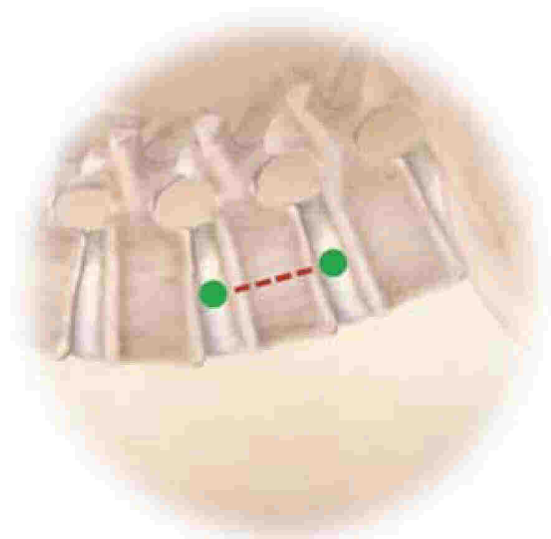

Figure 8

## Dissection to the Psoas

- Step 1** After making a single skin incision, the subcutaneous fat layers are dissected until the abdominal musculature is reached. A monopolar cautery may be used for hemostasis and a small self-retaining retractor can be used for initial dissection of the skin and subcutaneous layer.
- Step 2** The external oblique fascia will be the first plane encountered and is the only layer that will need to be sharply incised. A Kelly Clamp is then used to bluntly spread through the fibers of the external oblique, internal oblique and transversalis muscles. All dissection is done in line with the muscle fibers as these muscles layers run in opposite directions. After bluntly penetrating the transversalis fascia, the yellow retroperitoneal fat is exposed (**Figure 9**).

- Step 3** Once inside the retroperitoneal space, the index finger is used to follow the internal abdominal wall posteriorly down to the psoas muscle, which can be visualized. Use of the finger to sweep the peritoneal contents as well as the retroperitoneal fat anteriorly will allow a clear path down to the psoas muscle (**Figure 10**).

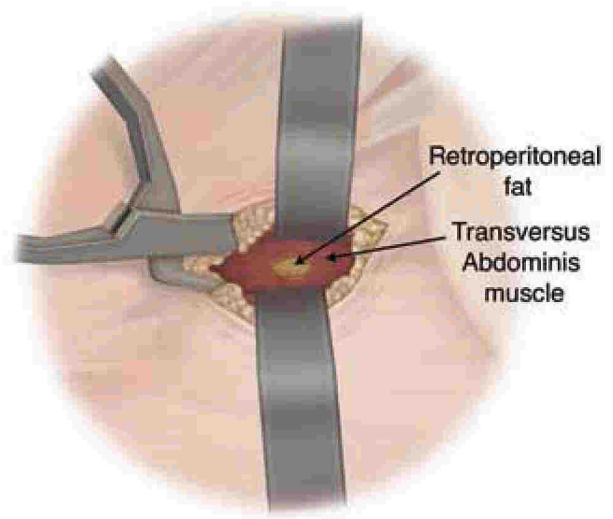

Figure 9

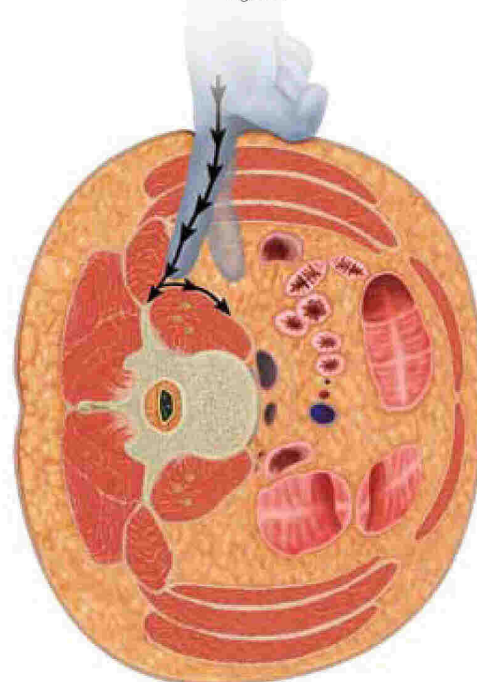

Figure 10

### Helpful Tip

*Palpating the quadratus muscle, followed by the tip of the transverse process and finally the psoas muscle will verify that the correct retroperitoneal plane is being entered and ensures that the peritoneum is not compromised.*

## Neuromonitoring through the Psoas

**Step 1** After a safe retroperitoneal pathway to the psoas has been established, the NIM® X-PAK Probe is guided down to the psoas while using the finger to protect the peritoneal membrane. The NIM® X-PAK Probe includes an electrified handle stylet assembly and an insulated cannula that enables controlled electrification at the tip of the device (Figure 11).

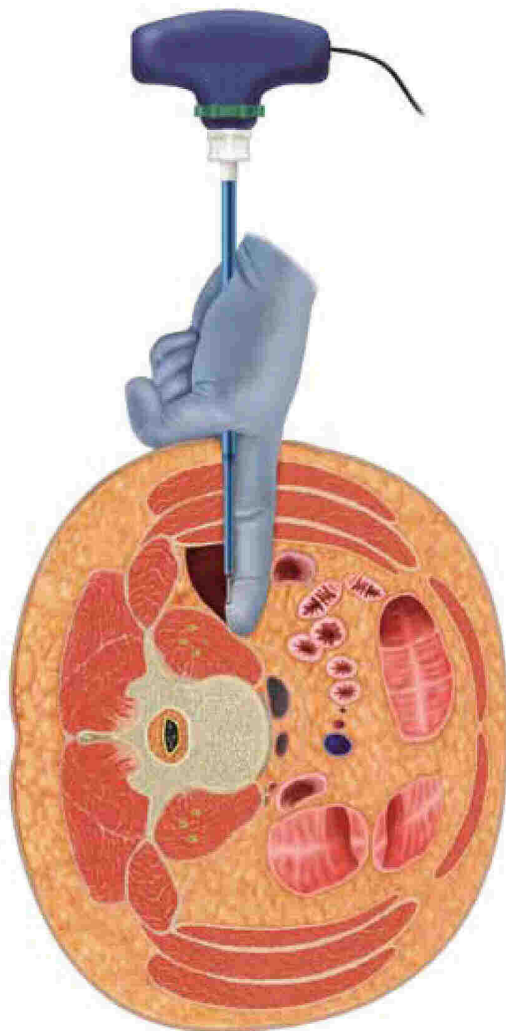

Figure 11

**Step 2** A Needle Driver is used to position the NIM® X-PAK Probe onto the top surface of the psoas. The entry point of the NIM® X-PAK Probe into the psoas should be targeted between the anterior half to third of the disc space in order to avoid the nerves of the lumbar plexus and to remain posterior to vascular structures. Cadaver studies have shown that the motor nerves typically reside in the posterior one third of the psoas muscle (Figure 12). Lateral fluoroscopy is used to make adjustments until the NIM® X-PAK Probe is in the proper position (Figure 13).

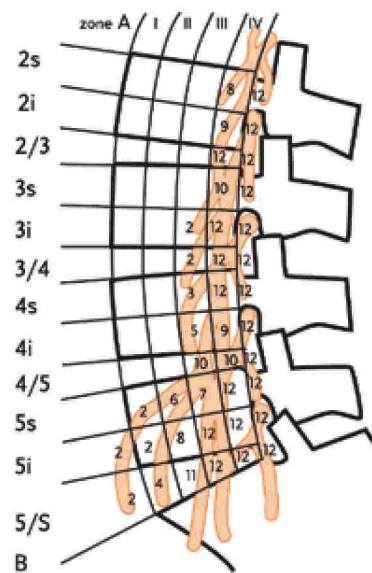

Figure 12



Figure 13



## Neuromonitoring through the Psoas *continued*

**Step 3** After the proper position has been established, carefully pass the NIM® X-PAK Probe through the psoas muscle. As the fibers of the muscle are being split, current is delivered to monitor for any neural structures. The recommended stimulating current setting is between 6-8 milliamps. If an EMG response is generated at this level, the NIM® X-PAK Probe should be repositioned slightly anterior until a nerve free pathway is located (**Figure 14**).

**Helpful Tip**

When monitoring with the NIM-ECLIPSE® Spinal System, the surgeon has the additional option of setting the machine to nerve proximity mode. In this mode, the system will send out a cycling current to continuously search for the stimulus threshold required to elicit an EMG response. The displayed current value will decrease as the NIM® X-PAK Probe is moved closer to a nerve. Ensuring threshold values above 8 milliamps is recommended (**Figure 15**).

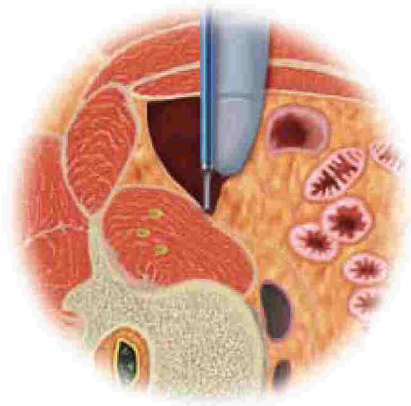

Figure 14



Figure 15

**Step 4** After the NIM® X-PAK Probe has safely dissected through the psoas, the tip of the probe as well as a portion of the insulated cannula should be tapped into the disc space to secure its location (**Figure 16**).

**Step 5** AP fluoroscopy is used to confirm proper probe alignment into the disc space and the blue stimulating handle is then removed, leaving only the insulated cannula within the disc space. A guidewire is then placed through the cannula into the desired disc space and its position confirmed with AP fluoroscopy (**Figure 17**).



Figure 16

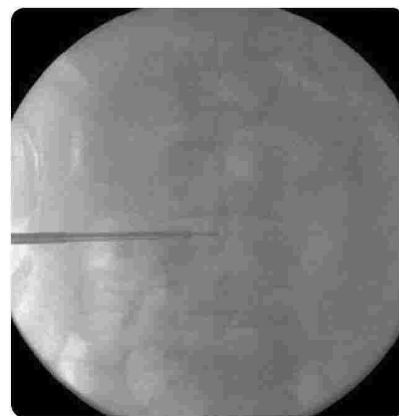

Figure 17

## Dilation and Retractor Placement

- Step 1** With the Guidewire in place, sequential dilation is used to spread the fibers of the psoas up to a diameter of 22mm and free-running EMG is active to detect any mechanical affect to the nerve roots (**Figure 18**).
- Step 2** Measure the depth from the skin to the disc space using the graduated markings on the dilators and select the appropriate retractor blades (**Figure 19**). Attach the blades to the Direct Lateral Retractor base and place the assembly over the Grooved Dilator (**Figure 20**). The Retractor should be advanced employing a back and forth twisting motion with only gentle downward pressure through the fascia and muscle. This technique helps to ensure the facial and muscle fibers are not pulled down into the surgical corridor.

### Helpful Tip

To minimize the amount of residual muscle, employ a back and forth twisting motion with each dilator and use AP fluoroscopy to confirm that each dilator has reached the disc space. The first dilator may be extended slightly into the disc space to ensure complete dilation through the psoas muscle.

### Important

The grooves on the largest dilator should be aligned cephalad and caudal and must be aligned with the corresponding retractor Stability Pin channels on the blades. Failure to mate the grooves could cause the blades to splay.

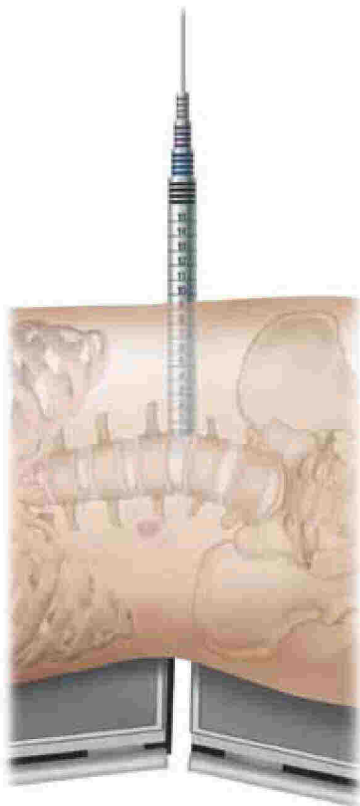

Figure 18



Figure 19

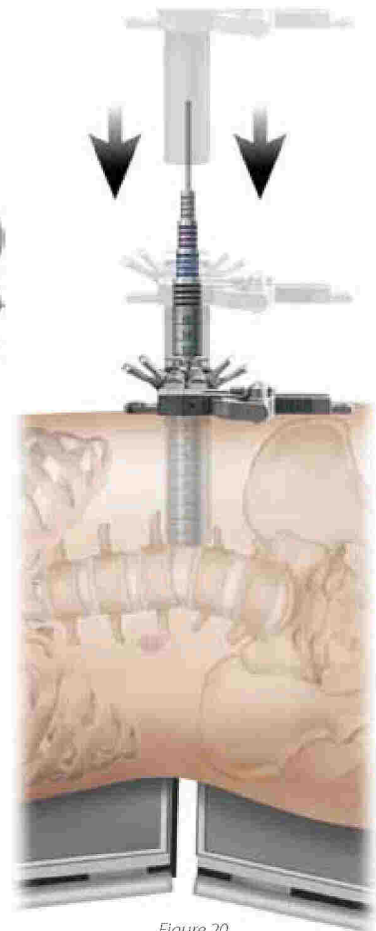

Figure 20

## Dilation and Retractor Placement *continued*

**Step 3** The Retractor Assembly is then attached to the Flexible Arm using the Rotating Flex Arm Attachment to provisionally maintain retractor position (Figure 21).

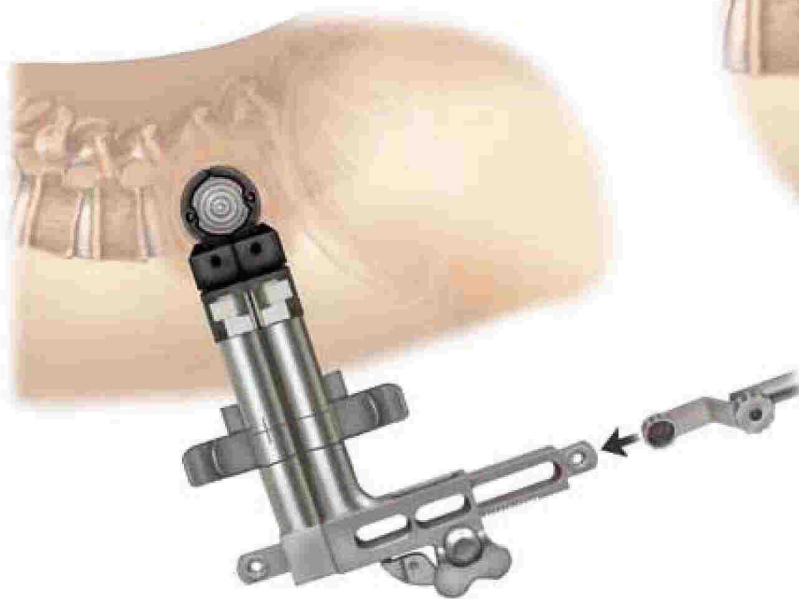

Figure 21

**Step 4** Use the NIM® Ball-tip Probe to test both Stability Pin channels of the Retractor Blades to ensure a nerve free pathway before placing a pin (Figure 22).

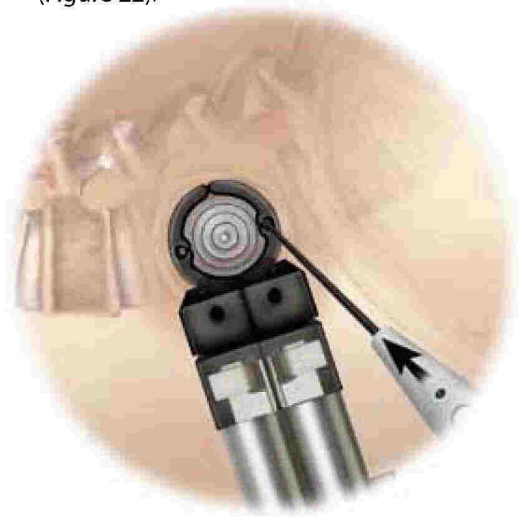

Figure 22

## Dilation and Retractor Placement *continued*

**Step 5** Insert a Stability Pin through one of the retractor blades to help prevent retractor migration during the procedure (**Figure 23**). Use the Stability Pin Driver to thread the pin in the channel of whichever blade is closest to the end plate (**Figure 24**).

**Step 6** With the Stability Pin in place, the Dilator Tubes are removed, leaving only the Retractor Assembly and Guidewire. The Guidewire may be left in place as a final reference point to verify position.

**Step 7** A final lateral fluoroscopy image is taken to confirm proper retractor placement over the lateral spine (**Figure 25**).

**Important**

*Placement near the end plate will avoid the middle of the vertebral body where the segmental vessels typically course.*

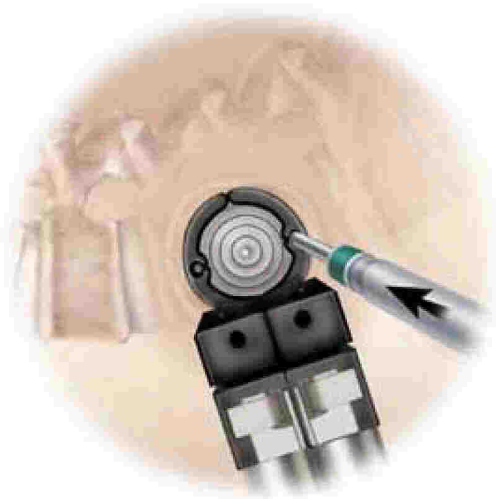

Figure 23

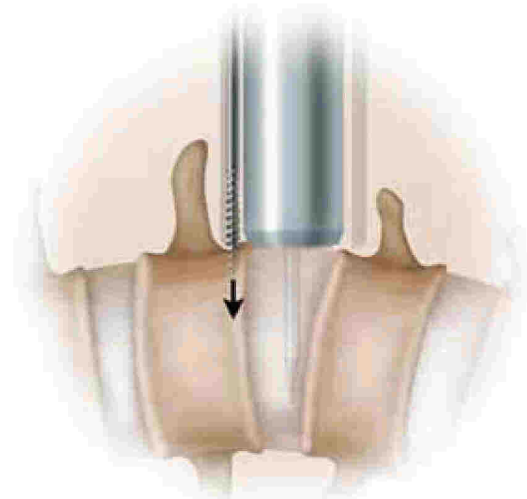

Figure 24



Figure 25

## Disc Preparation

**Step 1** The MAST QUADRANT™ Illumination System is attached to the retractor blades by placing the metal tips of the light source into the holes on the top of the blades and then sliding the tips under the built-in retaining sleeves (**Figure 26**).

**Step 2** Typically, a thin layer of soft tissue will remain at the base of the retractor blades. The NIM® Ball-tip Probe is used to stimulate in all four quadrants at the Retractor Base in order to identify any nerve structures that may be present in the residual muscle.

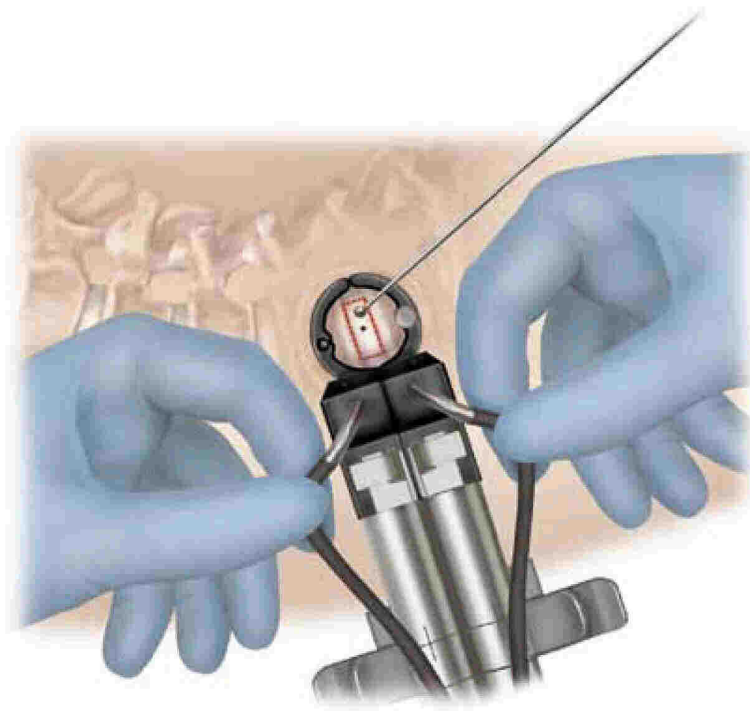

Figure 26

## Disc Preparation *continued*

**Step 3** A Penfield 4 is then used to sweep the residual muscle off of the disc space until the annulus is visualized.

**Step 4** The annulus is then incised and an annulotomy at least 18mm in length is created using the Bayoneted Knife (Figures 27 and 28).

**Step 5** A thorough discectomy is then performed using pituitaries and other disc preparation instruments (Figure 29).

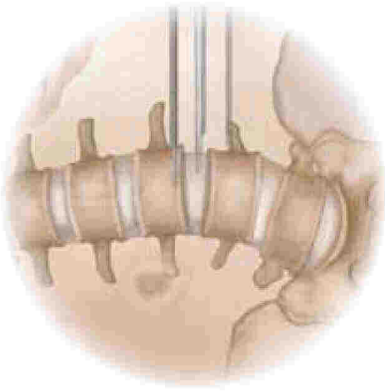

Figure 27

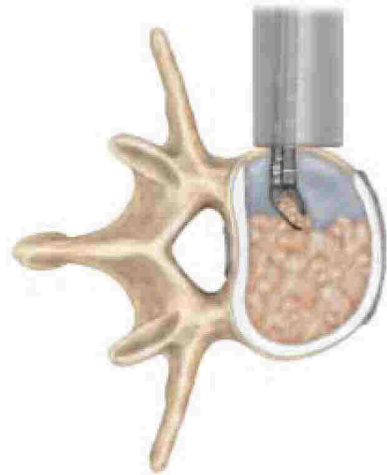

Figure 29

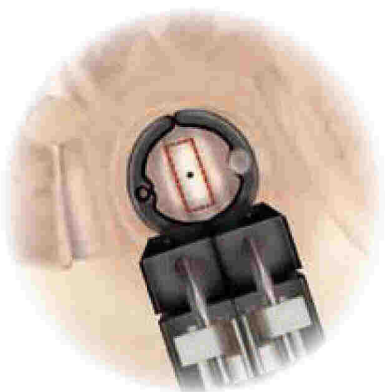

Figure 28

## Disc Preparation *continued*

**Step 6** A large Cobb is passed along both end plates to the contralateral annulus (**Figure 30**). A mallet is then used to gently release both the superior and inferior aspects of the contralateral annulus (**Figure 31**). This step is critical to ensure that appropriate distraction and coronal alignment can be achieved.

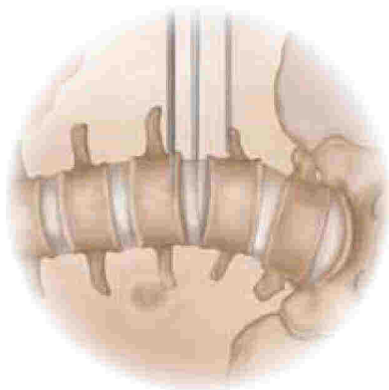

Figure 30

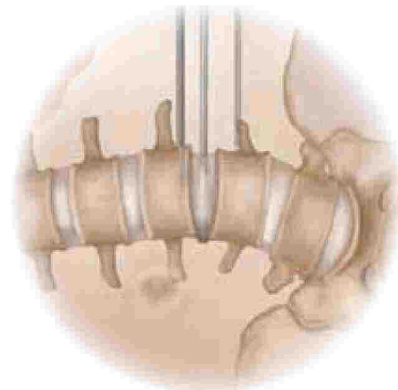

Figure 32

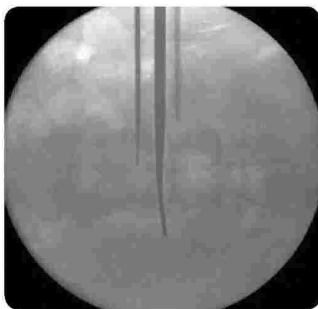

Figure 31

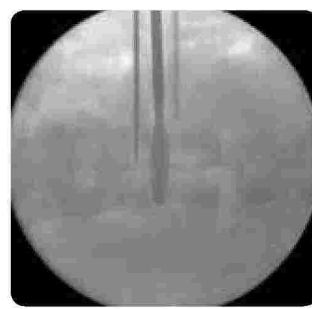

Figure 33

### ! Important

*It is important that the working trajectory of the instruments stay perpendicular to the floor in order to avoid injury to vessels or nerve structures.*

## Disc Preparation *continued*

**Step 8** Serrated curettes, a Ring curette, Combo Tools are used to ensure proper end plate preparation. It is extremely important that the end plates be meticulously prepared for fusion by removing the cartilaginous disc without destroying the cortical end plates (**Figure 34 and 35**).

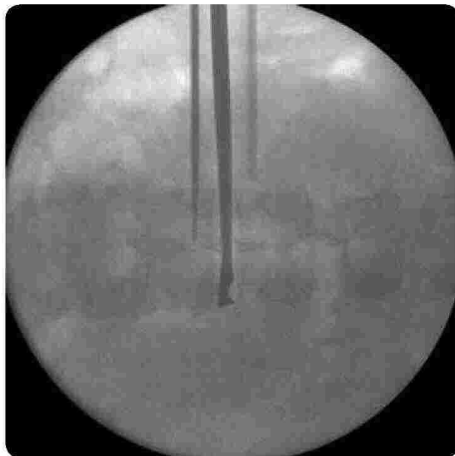

Figure 34

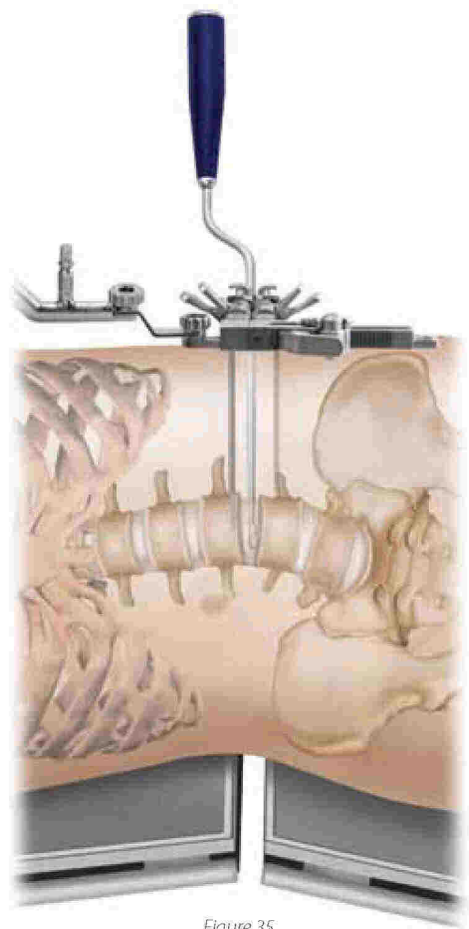

Figure 35



## Trialing

**Step 1** The disc space is sequentially distracted with Trials until adequate disc space height is obtained and adequate foraminal size is restored.

**Step 2** The Trial is passed through the Retractor and impacted into the disc space. A properly sized Trial should be centered with the spinous process and span the ring apophysis in order to reach fully across the vertebral body end plate (**Figure 36 and 37**).

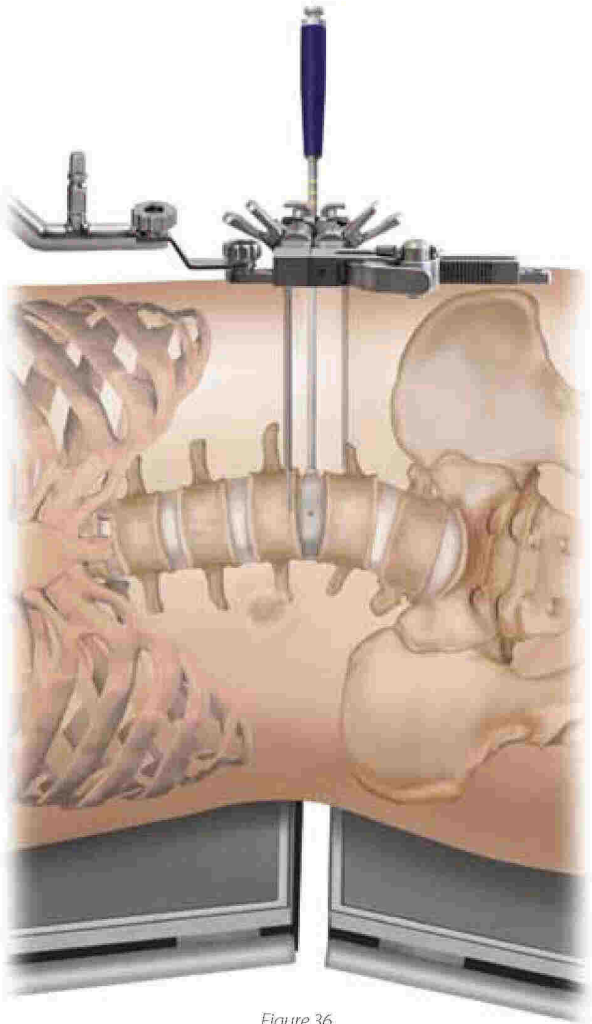

Figure 36

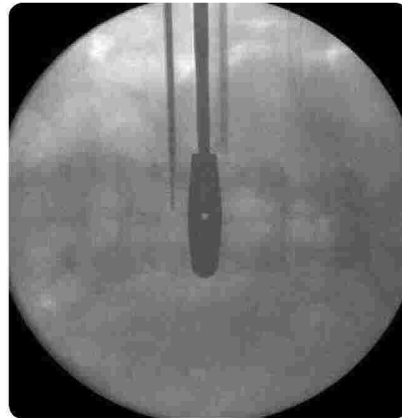

Figure 37

## Implant Placement

**Step 1** Once trialing is complete, the corresponding CLYDESDALE™ Spinal System implant is attached to the Inserter (**Figure 38**). If using a lordotic implant, take note of the anterior side of the implant, marked “ANTERIOR”.

**Step 2** Before inserting the CLYDESDALE™ Spinal System device, place autograft in the implant’s central cavity. A mallet is then used to gently insert the implant while monitoring placement under AP fluoroscopy. Care should be taken to ensure the CLYDESDALE™ Spinal System implant is aligned properly.

**Step 3** After the implant is positioned in the center of the disc space from a medial/lateral perspective, the inserter is unthreaded from the implant and removed (**Figures 39, 40, and 41**).

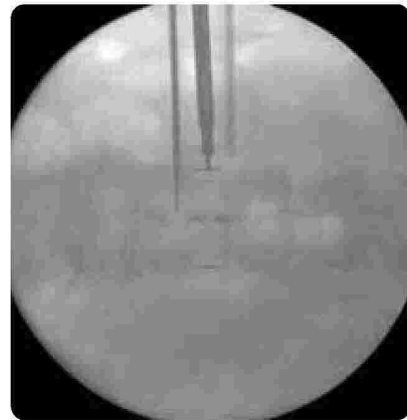

Figure 39



Figure 38

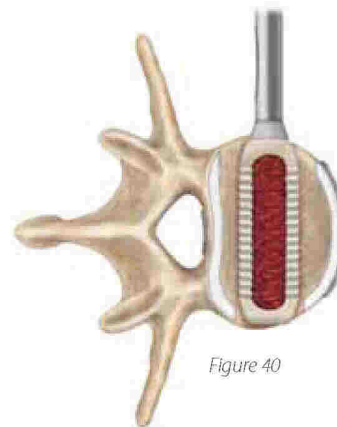

Figure 40

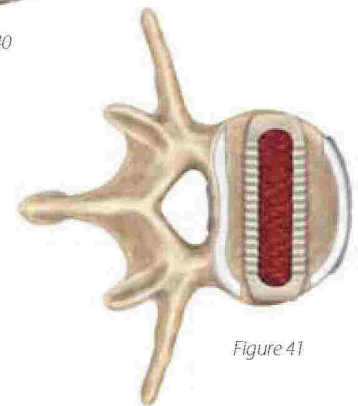

Figure 41

## Closure

- Step 1** After the autograft material has been inserted into the disc space, the Stability Pin may be unthreaded and removed.
- Step 2** The retractor is then detached from the Flex Arm and the Retractor Blades are carefully withdrawn from the surgical site. As the Retractor is removed, the muscle and fat layers can be visualized closing back into place.
- Step 3** The surgical site is irrigated appropriately and the fascia over the external oblique is then closed with interrupted vicryl suture.
- Step 4** Finally, the subcutaneous layers and skin are closed and the skin is sealed with skin adhesive.

## Explantation

Should it be necessary to remove or reposition the CLYDESDALE™ Spinal System device, the Removal Tool may be used.

To remove the implant, first fit the tips of the Removal Tool with the divots at the end of the implant (**Figure 42**). Next, depress the trigger to lock onto the implant. Finally, attach the Slap Hammer to the Removal Tool and gently impact the Slap Hammer to facilitate implant removal (**Figure 43**).

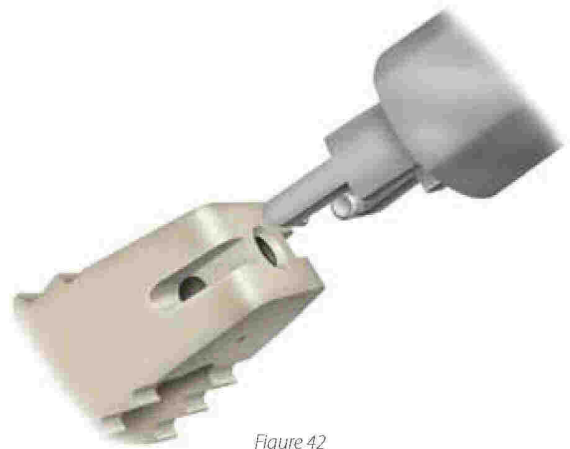

Figure 42

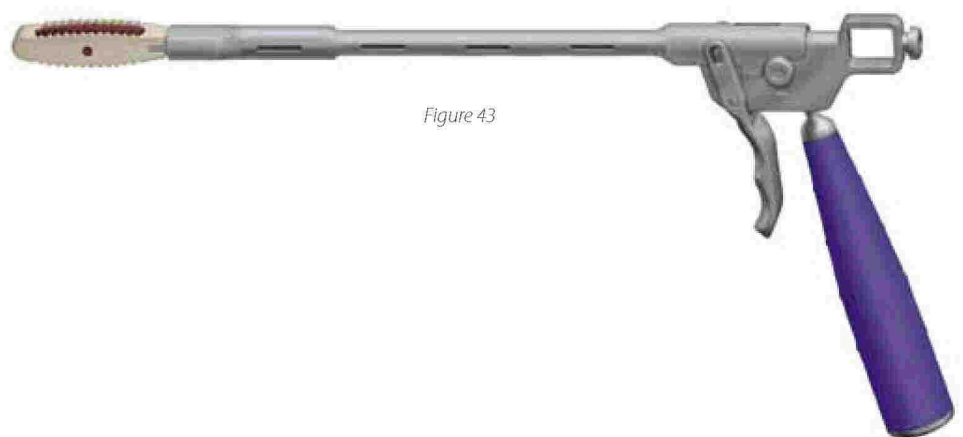

Figure 43

## Fixation

Supplemental instrumentation is then placed according to the appropriate surgical technique. The CLYDESDALE™ Spinal System can be used with any Medtronic posterior or anterior fixation system.



» CD HORIZON® SEXTANT® II  
Percutaneous Rod System

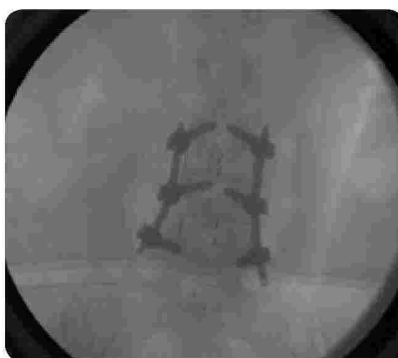

» CD HORIZON® LONGITUDE®  
Multi-level Percutaneous Fixation

## Product Ordering Information

### INSTRUMENT CASE 1

SPS02028 – Retractor and Kerrison Pituitary Trays

Part Number	Description	Set Quantity
<b>Retractor, Blades, Pins, and Driver</b>		
9569000	Retractor Base	1
9568010	Rotating Flex Arm Attachment	1
9567319	9cm Retractor Blade Internal Pin, Right	1
9567309	9cm Retractor Blade Internal Pin, Left	1
9567310	10cm Retractor Blade Internal Pin, Right	1
9567300	10cm Retractor Blade Internal Pin, Left	1
9567311	11cm Retractor Blade Internal Pin, Right	1
9567301	11cm Retractor Blade Internal Pin, Left	1
9567312	12cm Retractor Blade Internal Pin, Right	1
9567302	12cm Retractor Blade Internal Pin, Left	1
9567313	13cm Retractor Blade Internal Pin, Right	1
9567303	13cm Retractor Blade Internal Pin, Left	1
9567315	15cm Retractor Blade Internal Pin, Right	1
9567305	15cm Retractor Blade Internal Pin, Left	1
9569309	9cm Blade Pin	2
9569310	10cm Blade Pin	2
9569311	11cm Blade Pin	2
9569312	12cm Blade Pin	2
9569313	13cm Blade Pin	2
9569315	15cm Blade Pin	2
8970400	Stability Pin Driver	1
<b>Dilators</b>		
9560420	5.3cm Dilator	1
9561421	10.6cm Dilator	1
9561422	16.0cm Dilator	1
9561424	20.8cm Grooved Dilator	1
<b>Guidewires</b>		
8670002	Guidewire Sharp (long)	2
8670005	Guidewire – Trocar Tip 1.6mm, 350mm (short)	2
<b>Kerrisons and Pituitaries</b>		
2940068	3mm Rotate Kerrison Punch	1
2940069	5mm Rotate Kerrison Punch	1
2940075	Pituitary Rongeur, 4 × 10 Straight	1
2940076	Pituitary Rongeur, 4 × 10 Up	1

### INSTRUMENT CASE 2

SPS02027 – CLYDESDALE™ Trial and Inserter Removal Trays

Part Number	Description	Set Quantity
<b>Trials</b>		
2986845	8 × 45 DL Trial	1
2986850	8 × 50 DL Trial	1
2986855	8 × 55 DL Trial	1
2986045	10 × 45 DL Trial	1
2986050	10 × 50 DL Trial	1
2986055	10 × 55 DL Trial	1
2986245	12 × 45 DL Trial	1
2986250	12 × 50 DL Trial	1
2986255	12 × 55 DL Trial	1
2986445	14 × 45 DL Trial	1
2986450	14 × 50 DL Trial	1
2986455	14 × 55 DL Trial	1
2986645	16 × 45 DL Trial	1
2986650	16 × 50 DL Trial	1
2986655	16 × 55 DL Trial	1
<b>Instruments</b>		
9074002	Slap Hammer	1
2982002	DL Removal Tool	1
2982001	DL Threaded Inserter	1
<b>INSTRUMENT CASE 4</b>		
SPS02029 – Instrument Trays 1 and 2		
Part Number	Description	Set Quantity
<b>Disc Preparation Instruments Tray 1</b>		
2940050	Combo Tool	1
2940051	Angled Combo Tool	1
2940052	Reverse Angle Combo Tool	1
2940053	Straight Serrated Cup Curette	1
2940054	Angled Serrated Cup Curette	1
2940056	Straight Ring Curette	1
2940055	Reverse Angle Serrated Cup Curette	1
2940057	10mm Cobb Elevator	1
2940059	18mm Cobb Elevator	1
<b>Disc Preparation Instruments Tray 2</b>		
2940186	6/8mm Distractor	1
9561554	Wide Nerve Root Retractor, Long	1
9569650	Bayoneted Penfield 4 Push/Pull Long	1
2940200	Long Suction	2
2900165	Cannulated Reamer T-Handle	2
2941608	8mm Shaver, 45mm length	1
2941610	10mm Shaver, 45mm length	1
2941612	12mm Shaver, 45mm length	1
2941614	14mm Shaver, 45mm length	1
2941616	16mm Shaver, 45mm length	1

NUVA0000043

## Product Ordering Information *continued*

### DISPOSABLE CASES

SPS00589 – Disposables

Part Number	Description	Set Quantity
<b>NIM-SPINE® Probes, Dilator, Light Source, and Knife</b>		
9450015	NIM-SPINE® Ball-tip Probe	1
9450069	NIM® X-PAK Probe	1
9560658	MAST QUADRANT™ Illumination System	1
9450070	5.3mm Dilator (Plastic)	1
9560659	Bayoneted Discectomy Knife	1

### INSTRUMENT CASE 3

SPS00586 – Flex Arm Tray

Part Number	Description	Set Quantity
<b>Flex Arm and Attachment</b>		
9561523	Bed Rail Clamp	1
9561524	Flexible Arm	1

### CLYDESDALE™ SPINAL SYSTEM IMPLANTS

Part Number	Description
<b>6° CLYDESDALE™ Spinal System SPS02156</b>	
2968845	8mm × 45mm
2968850	8mm × 50mm
2968855	8mm × 55mm
2968860	8mm × 60mm
2968045	10mm × 45mm
2968050	10mm × 50mm
2968055	10mm × 55mm
2968060	10mm × 60mm
2968245	12mm × 45mm
2968250	12mm × 50mm
2968255	12mm × 55mm
2968260	12mm × 60mm
2968445	14mm × 45mm
2968450	14mm × 50mm
2968455	14mm × 55mm
2968460	14mm × 60mm
2968645	16mm × 45mm
2968650	16mm × 50mm
2968655	16mm × 55mm
2968660	16mm × 60mm
<b>0° CLYDESDALE™ Spinal System SPS02157</b>	
2969845	8mm × 45mm
2969850	8mm × 50mm
2969855	8mm × 55mm
2969045	10mm × 45mm
2969050	10mm × 50mm
2969055	10mm × 55mm
2969245	12mm × 45mm
2969250	12mm × 50mm
2969255	12mm × 55mm
2969445	14mm × 45mm
2969450	14mm × 50mm
2969455	14mm × 55mm
2969645	16mm × 45mm
2969650	16mm × 50mm
2969655	16mm × 55mm

## Important Product Information

### IMPORTANT INFORMATION FOR MEDTRONIC SOFAMOR DANEK INSTRUMENTS

#### Purpose:

This instrument is intended for use in surgical procedures.

#### Description:

Unless otherwise stated, instruments are made out of a variety of materials commonly used in orthopedic and neurological procedures including stainless steel and acetyl copolymer materials which meet available national or international standards specifications. Some instruments are made out of aluminium, and some with handles made of resin bonded composites, and while these can be steam autoclaved, certain cleaning fluids must not be employed. None of the instruments should be implanted.

#### Intended Use:

This instrument is a precision device which may incorporate a measuring function and has uses as described on the label.

Unless labeled for single use, this instrument may be re-used.

If there is any doubt or uncertainty concerning the proper use of this instrument, please contact MEDTRONIC SOFAMOR DANEK Customer Service for instructions. Any available surgical techniques will be provided at no charge.

#### Warnings:

The methods of use of instruments are to be determined by the user's experience and training in surgical procedures.

Do not use this instrument for any action for which it was not intended such as hammering, prying, or lifting.

This instrument should be treated as any precision instrument and should be carefully placed on trays, cleaned after each use, and stored in a dry environment.

To avoid injury, the instrument should be carefully examined prior to use for functionality or damage. A damaged instrument should not be used. Additional back-up instruments should be available in case of an unexpected need.

MEDTRONIC SOFAMOR DANEK does not and cannot warrant the use of this instrument nor any of the component parts upon which repairs have been made or attempted except as performed by MEDTRONIC SOFAMOR DANEK or an authorized MEDTRONIC SOFAMOR DANEK repair representative.

Implied warranties of merchantability and fitness for a particular purpose or use are specifically excluded. See the MSD catalog for further information about warranties and limitations of liability.

DO NOT IMPLANT THE INSTRUMENTS.

#### Possible Adverse Effects:

Breakage, slippage, misuse, or mishandling of instruments, such as on sharp edges, may cause injury to the patient or operative personnel.

Improper maintenance, handling, or poor cleaning procedures can render the instrument unsuitable for its intended purpose, or even dangerous to the patient or surgical staff.

Proper patient selection and operative care are critical to the success of the device and avoidance of injury during surgery. Read and follow all other product information supplied by the manufacturer of the implants or the instruments.

Special precautions are needed during pediatric use. Care should be taken when using instruments in pediatric patients, since these patients can be more susceptible to the stresses involved in their use.

There are particular risks involved in the use of instruments used for bending and cutting rods. The use of these types of instruments can cause injury to the patient by virtue of the extremely high forces which are involved. Do not cut rods in situ. In addition, any breakage of an instrument or the implant in this situation could be extremely hazardous. The physical characteristics required for many instruments does not permit them to be manufactured from implantable materials, and if any broken fragments of instruments remain in the body of a patient, they could cause allergic or infectious consequences.

**Over-bending, notching, striking and scratching of the implants with any instrument should be avoided to reduce the risk of breakage.** Under no circumstances should rods or plates be sharply or reverse bent, since this would reduce the fatigue life of the rod and increase the risk of breakage. When the configuration of the bone cannot be fitted with an available device and contouring of the device is absolutely necessary, contouring should be performed only with proper bending equipment, and should be performed gradually and with great care to avoid notching or scratching the device.

Extreme care should be taken to ensure that this instrument remains in good working order. Any surgical techniques applicable for use of this system should be carefully followed. During the procedure, successful utilization of this instrument is extremely important. Unless labeled for single use, this instrument may be reused. This instrument should not be bent or damaged in any way. Misuse of this instrument, causing corrosion, "freezing-up", scratching, loosening, bending and/or fracture of any or all sections of the instrument may inhibit or prevent proper function.

It is important that the surgeon exercise extreme caution when working in close proximity to vital organs, nerves or vessels, and that the forces applied while correcting the position of the instrumentation is not excessive, such that it might cause injury to the patient.

Excessive force applied by instruments to implants can dislodge devices, particularly hooks.

Never expose instruments to temperatures in excess of 134°C that may considerably modify the physical characteristics of the instruments.



**CAUTION : FEDERAL (U.S.) LAW RESTRICTS THESE DEVICES  
TO SALE BY OR ON THE ORDER OF A PHYSICIAN ONLY.**

**This device should be used only by physicians familiar with the device, its intended use, any additional instrumentation and any available surgical techniques.**

**For the best results MEDTRONIC SOFAMOR DANEK implants should only be implanted with MEDTRONIC SOFAMOR DANEK instruments.**

**Other complications to the patient and/or hospital staff may include, but are not limited to :**

1. Nerve damage, paralysis, pain, or damage to soft tissue, visceral organs or joints.
2. Breakage of the device, which could make necessary removal difficult or sometimes impossible, with possible consequences of late infection and migration. Breakage could cause injury to the patient or hospital staff.
3. Infection, if instruments are not properly cleaned and sterilized.
4. Pain, discomfort, or abnormal sensations resulting from the presence of the device.
5. Nerve damage due to surgical trauma.
6. Dural leak in cases of excessive load application.
7. Impingement of close vessels, nerves and organs by slippage or misplacement of the instrument.
8. Damage due to spontaneous release of clamping devices or spring mechanisms of certain instruments.
9. Cutting of skin or gloves of operating staff.
10. Bony fracture, in cases of deformed spine or weak bone.
11. Tissue damage to the patient, physical injury to operating staff and/or increased operating time that may result from the disassembly of multi-component instruments occurring during surgery.

#### Other Precautions:

1. Excessive forces when using bending or fixation instruments can be dangerous especially where bone friability is encountered during the operation.
2. Any form of distortion or excessive wear on instruments may cause a malfunction likely to lead to serious patient injury.
3. Regularly review the operational state of all instruments and if necessary make use of repair and replacement services.

#### Device Fixation:

Some surgeries require the use of instruments which incorporate a measuring function. Ensure that these are not worn, that any surface engravings are clearly visible.

Where there is a need for a specified tightening torque, this may normally be achieved with torque setting instruments supplied by MEDTRONIC SOFAMOR DANEK; the pointer on these instruments must indicate ZERO before use. If not, return for recalibration.

With small instruments, excess force, beyond the design strength of the instrument, can be caused even by simple manual overloading. Do not exceed recommended parameters.

To determine the screw diameter with the screw gauge, start with the smallest test hole.

#### Packaging:

MEDTRONIC SOFAMOR DANEK instruments may be supplied as either sterile or non-sterile. Sterile instruments will be clearly labeled as such on the package label. The sterility of instruments supplied sterile can only be assured if the packaging is intact.

Packages for both sterile and non-sterile components should be intact upon receipt. All sets should be carefully checked for completeness and all components should be carefully checked for signs of damage, prior to use. Damaged packages or products should not be used and should be returned to MEDTRONIC SOFAMOR DANEK.

Remove all packaging material prior to sterilization. Only sterile implants and instruments should be used in surgery. Always immediately re-sterilize all instruments used in surgery. Instruments should be thoroughly cleaned prior to re-sterilization. This process must be performed before handling, or before returning product to MEDTRONIC SOFAMOR DANEK.

#### Examination:

Instruments must always be examined by the user prior to use in surgery.

Examination should be thorough, and in particular, should take into account a visual and functional inspection of the working surfaces, pivots, racks, spring or torsional operation, cleanliness of location holes or cannulations, and the presence of any cracks, bending, bruising or distortion, and that all components of the instrument are complete.

**Never use instruments with obvious signs of excessive wear, damage, or that are incomplete or otherwise unfunctional.**

#### CLEANING AND DECONTAMINATION:

Unless just removed from an unopened Medtronic Sofamor Danek package, all instruments must be disassembled (if applicable) and cleaned using neutral cleaners before sterilization and introduction into a sterile surgical field or (if applicable) return of the product to Medtronic Sofamor Danek. Cleaning and disinfecting of instruments can be performed with aldehyde-free solvents at higher temperatures. Cleaning and decontamination must include the use of neutral cleaners followed by a deionized water rinse.

Note: certain cleaning solutions such as those containing formalin, glutaraldehyde, bleach and/or other alkaline cleaners may damage some devices, particularly instruments; these solutions should not be used. Also, many instruments require disassembly before cleaning.

All products should be treated with care. Improper use or handling may lead to damage and/or possible improper functioning of the device.

NUVA000045



## Important Product Information *continued*

### STERILIZATION:

Unless marked sterile and clearly labeled as such in an unopened sterile package provided by the company, all implants and instruments used in surgery must be sterilized by the hospital prior to use. Remove all packaging materials prior to sterilization. Only sterile products should be placed in the operative field. Unless specified elsewhere, these products are recommended to be steam sterilized by the hospital using the set of process parameters below:

METHOD	CYCLE	TEMPERATURE	EXPOSURE TIME
Steam	Pre-Vacuum	270°F (132°C)	4 Minutes
Steam	Gravity	250°F (121°C)	60 Minutes
Steam*	Pre-Vacuum*	273°F (134°C)*	20 Minutes*
Steam*	Gravity*	273°F (134°C)*	20 Minutes*

**NOTE:** Because of the many variables involved in sterilization, each medical facility should calibrate and verify the sterilization process (e.g. temperatures, times) used for their equipment.

**\*For outside the United States, some non-U.S. Health Care Authorities recommend sterilization according to these parameters so as to minimize the potential risk of transmission of Creutzfeldt-Jakob disease, especially of surgical instruments that could come into contact with the central nervous system.**

**It is important to note that a sterilization wrap, package or sterilization container system should be used to endorse the case or tray in order to maintain sterility.**

Although the treatment of the instrument, materials used, and details of sterilization have an important effect, for all practical purposes, there is no limit to the number of times instruments can be re-sterilized.

### Operative Use:

The physician should take precautions against putting undue stress on the spinal area with instruments. Any surgical technique instruction manual should be carefully followed. If an instrument breaks in surgery and pieces go into the patient, these pieces should be removed prior to closure and should not be implanted.

### Removal of Implants:

For the best results, the same type of MEDTRONIC SOFAMOR DANEK instruments as used for implantation should be used for implant removal purposes. Various sizes of screwdrivers are available to adapt to the removal drive sizes in auto break fixation screws.

It should be noted that where excessive bone or fibrous growth has occurred from the first surgery, there may be added stress on the removal instruments and the implants. Both instrument and implant may be prone to possible breakage. In this case it is necessary to first remove the bone and/or tissue from around the implants.

### Further Information:

**In case of complaint, or for supplementary information, please contact MEDTRONIC SOFAMOR DANEK.**

### Product Complaint:

Any Health Care Professionals (e.g., customer users of MEDTRONIC SOFAMOR DANEK instruments), who have any complaint or who have experienced dissatisfaction in the product quality, identity, durability, reliability, safety, effectiveness and/or performance, should notify the distributor, MEDTRONIC SOFAMOR DANEK. Further, if any instrument "malfunctions" (i.e., does not meet any of its performance specifications or otherwise does not perform as intended), or is suspected of doing so, the distributor or MEDTRONIC SOFAMOR DANEK should be notified immediately. If any MEDTRONIC SOFAMOR DANEK product ever "malfunctions" and may have caused or contributed to the death or serious injury of a patient, the distributor or MEDTRONIC SOFAMOR DANEK should be notified as soon as possible by telephone, FAX or written correspondence. When filing a complaint, please provide the component(s) name and number, lot number(s), your name and address, and the nature of the complaint.

©2009 MEDTRONIC SOFAMOR DANEK USA, Inc. All rights reserved.

Please contact your Sales Representative or Customer Service for the most up-to-date version of the package insert.

## Important Product Information *continued*

### IMPORTANT INFORMATION ON THE CLYDESDALE™ Spinal System

#### PURPOSE

This device is a PEEK (POLYETHERETHERKETONE) interbody fusion device intended for stabilization use and to promote bone fusion during the normal healing process following surgical correction of disorders of the spine. The product should be implanted only by a physician who is thoroughly knowledgeable in the implant's material and surgical aspects and who has been instructed as to its mechanical and material applications and limitations.

#### DESCRIPTION

The CLYDESDALE™ Spinal System consists of PEEK cages of various widths and heights, which include Tantalum markers. These devices can be inserted between two lumbar or lumbosacral vertebral bodies to give support and correction during lumbar interbody fusion surgeries. The hollow geometry of the implants allows them to be packed with autogenous bone graft.

No warranties, express or implied, are made. Implied warranties of merchantability and fitness for a particular purpose or use are specifically excluded. See the MDT Catalog or price list for further information about warranties and limitations of liability.

#### INDICATIONS

**The CLYDESDALE™ Spinal System is designed to be used with autogenous bone graft to facilitate interbody fusion and is intended for use with supplemental fixation systems cleared for use in the lumbar spine. The CLYDESDALE™ Spinal System is used for patients diagnosed with degenerative disc disease (DDD) at one or two contiguous levels from L2 to S1. These DDD patients may also have up to Grade 1 Spondylolisthesis or retrolisthesis at the involved levels. DDD is defined as discogenic back pain with degeneration of the disc confirmed by history and radiographic studies. These patients should be skeletally mature and have had six months of non-operative treatment. These implants may be implanted via a minimally invasive lateral approach.**

#### CONTRAINDICATIONS

**This device is not intended for cervical spine use.**

Contraindications include, but are not limited to:

1. Infection, local to the operative site
2. Signs of local inflammation,
3. Fever or leukocytosis,
4. Morbid obesity,
5. Pregnancy,
6. Mental illness,
7. Any other condition which would preclude the potential benefit of spinal implant surgery, such as the presence of tumors or congenital abnormalities, fracture local to the operating site, elevation of sedimentation rate unexplained by other diseases, elevation of white blood count (WBC), or a marked left shift in the WBC differential count.
8. Suspected or documented allergy or intolerance to composite materials,
9. Any case not needing a fusion,
10. Any case not described in the indications,
11. Any patient unwilling to cooperate with postoperative instructions.
12. Patients with a known hereditary or acquired bone fragility or calcification problem should not be considered for this type of surgery.
13. These devices must not be used for pediatric cases, nor where the patient still has general skeletal growth.
14. Spondylolisthesis unable to be reduced to Grade 1.
15. Any case where the implant components selected for use would be too large or too small to achieve a successful result.
16. Any case that requires the mixing of metals from two different components or systems.
17. Any patient having inadequate tissue coverage over the operative site or inadequate bone stock or quality.
18. Any patient in which implant utilization would interfere with anatomical structures or expected physiological performance.
19. Prior fusion at the level to be treated.

**NOTA BENE: Although not absolute contraindications, conditions to be considered as potential factors for not using this device include:**

1. Severe bone resorption.
2. Osteomalacia.
3. Severe osteoporosis.

#### POTENTIAL ADVERSE EVENTS

Adverse effects may occur when the device is used either with or without associated instrumentation.

The potential risk of adverse effects as a result of movement and non-stabilization may increase in cases where associated complementary support is not employed. Potential adverse events include but are not limited to:

1. Implant migration.
2. Breakage of the device(s).
3. Foreign body reaction to the implants including possible tumor formation, auto immune disease, and/or scarring.
4. Pressure on the surrounding tissues or organs.
5. Loss of proper spinal curvature, correction, height, and/or reduction.
6. Infection.
7. Bone fracture or stress shielding at, above, or below the level of surgery.

8. Non-union (or pseudoarthrosis).
9. Loss of neurological function, appearance of radiculopathy, dural tears, and/or development of pain. Neurovascular compromise including paralysis temporary or permanent retrograde-ejaculation in males, or other types of serious injury. Cerebral spinal fluid leakage.
10. Haemorrhage of blood vessels and/or hematomas.
11. Discitis, arachnoiditis, and/or other types of inflammation.
12. Deep venous thrombosis, thrombophlebitis, and/or pulmonary embolus.
13. Bone graft donor site complication.
14. Inability to resume activities of normal daily living.
15. Early or late loosening or movement of the device(s).
16. Urinary retention or loss of bladder control or other types of urological system compromise.
17. Scar formation possibly causing neurological compromise or compression around nerves and/or pain.
18. Fracture, microfracture, resorption, damage, or penetration of any spinal bone (including the sacrum, pedicles, and/or vertebral body) and/or bone graft or bone graft harvest site at, above, and/or below the level of surgery. Retropulsed graft.
19. Herniated nucleus pulposus, disc disruption or degeneration at, above, or below the level of surgery.
20. Loss of or increase in spinal mobility or function.
21. Reproductive system compromise, including sterility, loss of consortium, and sexual dysfunction.
22. Development of respiratory problems, e.g. pulmonary embolism, atelectasis, bronchitis, pneumonia, etc.
23. Change in mental status.
24. Cessation of any potential growth of the operated portion of the spine.
25. Death.

#### WARNINGS AND PRECAUTIONS

A successful result is not always achieved in every surgical case. This fact is especially true in spinal surgery where other patient conditions may compromise the results. Use of this product without bone graft or in cases that do not develop a union will not be successful.

Preoperative and operating procedures, including knowledge of surgical techniques, good reduction, and correct selection and placement of the implants are important considerations in the successful utilization of the system by the surgeon. Further, the proper selection and the compliance of the patient will greatly affect the results. Patients who smoke have been shown to have a reduced incidence of bone fusion. These patients should be advised of this fact and warned of this consequence. Obese, malnourished, and / or alcohol / drug abuse patients and those with poor muscle and bone quality and / or nerve paralysis are also poor candidates for spinal fusion.

Patients with previous spinal surgery at the levels to be treated may have different clinical outcomes compared to those with a previous surgery.

**PHYSICIAN NOTE:** Although the physician is the learned intermediary between the company and the patient, the important medical information given in this document should be conveyed to the patient.

**USA** For US Audiences Only

**CAUTION: FEDERAL LAW (USA) RESTRICTS THESE DEVICES TO SALE BY OR ON THE ORDER OF A PHYSICIAN.**

#### IMPLANT SELECTION

The selection of the proper size, shape and design of the implant for each patient is crucial to the success of the procedure. Surgical implants are subject to repeated stresses in use, and their strength is limited by the need to adapt the design to the human anatomy. Unless great care is taken in patient selection, placement of the implant, and postoperative management to minimize stresses on the implant, such stresses may cause material fatigue and consequent breakage or loosening of the device before the fusion process is complete, which may result in further injury or the need to remove the device prematurely.

#### DEVICE FIXATION

Installation and positional adjustment of implants must only be done with special ancillary instruments and equipment supplied and designated by MEDTRONIC. In the interests of patient safety, it is therefore recommended that MEDTRONIC implants are not used with devices from any other source.

Never, under any circumstances, reuse a CLYDESDALE™ Spinal System device. Even when a removed device appears undamaged, it may have small defects or internal stress patterns that may lead to early breakage.

#### PREOPERATIVE

1. Only patients that meet the criteria described in the indications should be selected.
2. Patient conditions and / or predispositions such as those addressed in the aforementioned contraindications should be avoided.
3. Care should be taken in the handling and storage of the device(s). They should not be scratched or damaged. Devices should be protected during storage especially from corrosive environments.
4. Further information about this system will be provided upon request.
5. The surgeon should be familiar with the various devices before use and should personally verify that all devices are present before the surgery begins.
6. The size of device for the case should be determined prior to beginning the surgery. An adequate inventory of implant sizes should be available at the time of surgery, including sizes larger and smaller than those expected to be used.
7. Unless supplied sterile, all devices should be cleaned and sterilized before use. Additional sterile components should be available in case of any unexpected need.

NUVA0000047

## Important Product Information *continued*

### INTRAOPERATIVE

1. The instructions in any available CLYDESDALE™ Spinal System surgical technique manual should be carefully followed.
2. At all times, extreme caution should be used around the spinal cord and nerve roots. Damage to the nerves will cause loss of neurological functions.
3. Breakage, slippage, or misuse of instruments or implants may cause injury to the patient or operative personnel.
4. To assure proper fusion below and around the location of the fusion, autogenous bone graft must be used.
5. Bone cement should not be used, because this material may make removal of these components difficult or impossible. The heat generated from the curing process may damage or deform the PEEK devices.

### POSTOPERATIVE

The physician's postoperative directions and warnings to the patient and the corresponding patient compliance, are extremely important.

1. Detailed instructions on the use and limitations of the device should be given to the patient. The patient must be warned that loosening, and /or breakage of the device(s) are complications which may occur as result of early or excessive weight-bearing, muscular activity or sudden jolts or shock to the spine.
2. The patient should be advised not to smoke or consume excess alcohol, during period of the bone fusion process.
3. The patient should be advised of the inability to bend at the point of spinal fusion and taught to compensate for this permanent physical restriction in body motion.
4. It is important that immobilization of union is established and confirmed by roentgenographic examination. If a non-union develops or if the components loosen, migrate, and / or break, the devices should be revised and /or removed immediately before serious injury occurs.
5. CLYDESDALE™ Spinal System implants are interbody devices and are intended to stabilize the operative area during the fusion process.
6. Any retrieved devices should be treated in such a manner that reuse in another surgical procedure is not possible.

### PACKAGING

Devices are supplied in a sterile form. Packages for each of the components should be intact upon receipt. Once the seal on the package has been broken, the product should not be re-sterilized. If a loaner or consignment system is used, all sets should be carefully checked for completeness and all components including instruments should be carefully checked to ensure that there is no damage prior to use. Damaged packages or products should not be used, and should be returned to MEDTRONIC.

### CLEANING AND DECONTAMINATION

Unless just removed from an unopened MEDTRONIC package, all instruments and implants must be disassembled (if applicable) and cleaned using neutral cleaners before sterilization and introduction into a sterile surgical field or (if applicable) return of the product to MEDTRONIC. Cleaning and disinfecting of instruments can be performed with aldehyde-free solvents at higher temperatures. Cleaning and decontamination must include the use of neutral cleaners followed by a deionized water rinse.

Note: Certain cleaning solutions such as those containing formalin, glutaraldehyde, bleach and/or other alkaline cleaners may damage some devices, particularly instruments; these solutions should not be used. Also, many instruments require disassembly before cleaning.

All products should be treated with care. Improper use or handling may lead to damage and/or possible improper functioning of the device.

### STERILIZATION

Devices are supplied in a sterile form. Once the seal on the package has been broken, the product should not be re-sterilized. When supplemental fixation is used, refer to the package insert of the supplemental instrumentation for sterilization information.

### PRODUCT COMPLAINTS

Any Health Care Professional (e.g., customer or user of this system of products), who has any complaints or who has experienced any dissatisfaction in the product quality, identity, durability, reliability, safety, effectiveness and/or performance, should notify the distributor or MEDTRONIC. Further, if any of the implanted spinal system component(s) ever malfunctions, (i.e., does not meet any of its performance specifications or otherwise does not perform as intended), or is suspected of doing so, the distributor should be notified immediately. If any MEDTRONIC product ever "malfunctions" and may have caused or contributed to the death or serious injury of a patient, the distributor should be notified immediately by telephone, fax or written correspondence. When filing a complaint, please provide the component(s) name and number, lot number(s), your name and address, the nature of the complaint and notification of whether a written report from the distributor is requested.

### FURTHER INFORMATION

Recommended directions for use of this system (surgical operative techniques) are available at no charge upon request. If further information is needed or required, please contact MEDTRONIC.



**Medtronic B.V.**  
Earl Bakkenstraat 10  
6422 PJ Heerlen  
The Netherlands  
Tel: + 31 45 566 80 00



Medtronic Sofamor Danek USA, Inc.  
1800 Pyramid Place  
Memphis, TN 38132  
Telephone 800 933 2635 (In U.S.A.)  
901 396 3133 (Outside of U.S.A.)  
Fax 901 396 0356

©2009 MEDTRONIC SOFAMOR DANEK. All rights reserved.

Please contact your Sales Representative or Customer Service for the most up-to-date version of the package insert.

For the other systems/devices in this technique, please contact your Medtronic Sales Representative for the surgical technique and/or package insert.

NUVA0000048

## Notes

Notes

## Notes

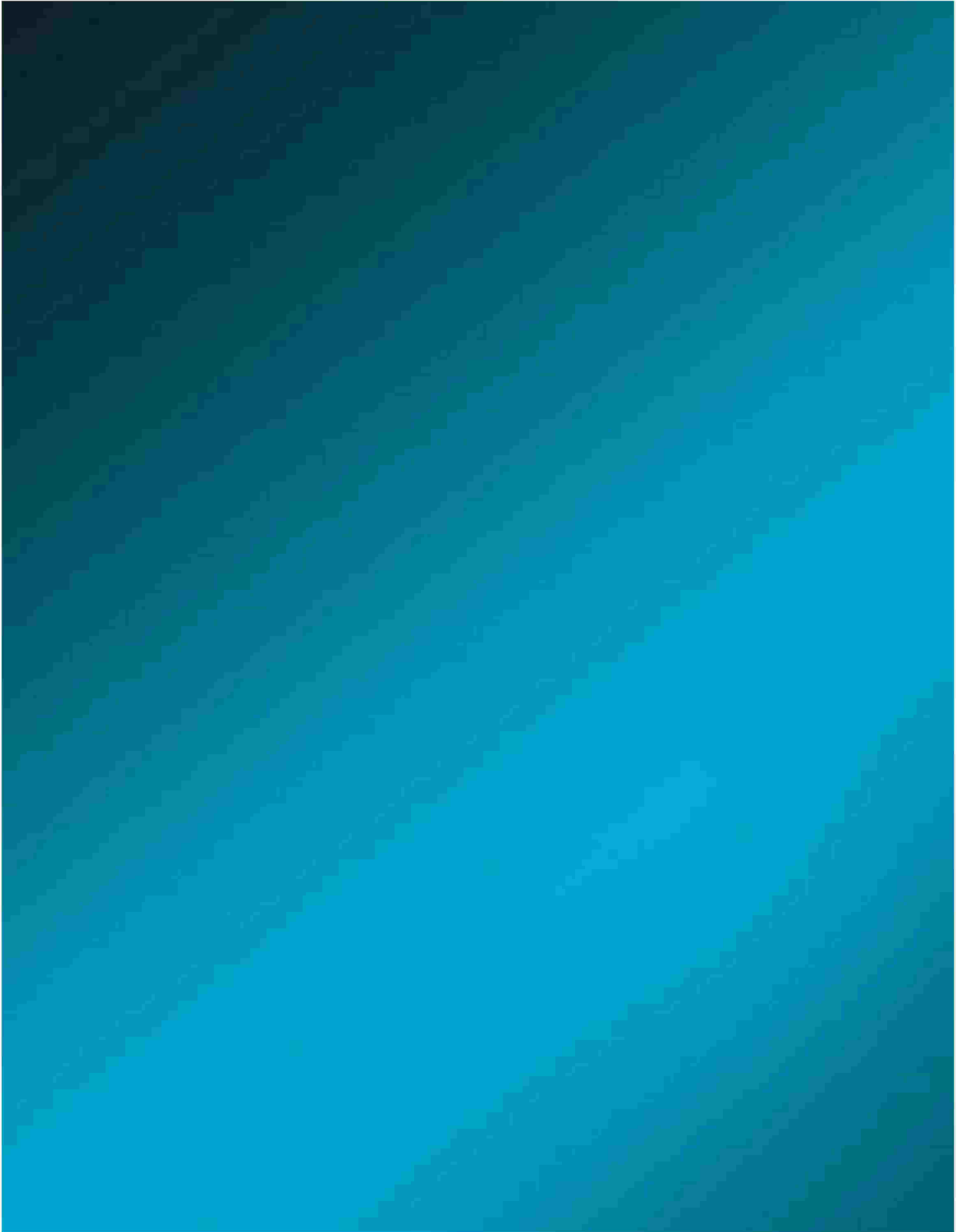

NUVA0000052

\*The NIM-ECLIPSE® Spinal System is manufactured by Axon Systems, Inc.  
Distributed by Medtronic.

[www.sofamordanek.com](http://www.sofamordanek.com)

**Medtronic**

Spinal and Biologics Business  
Worldwide Headquarters

2600 Sofamor Danek Drive  
Memphis, TN 38132

1800 Pyramid Place  
Memphis, TN 38132

(901) 396-3133  
(800) 876-3133  
Customer Service: (800) 933-2635

For more information visit  
[www.myspinetools.com](http://www.myspinetools.com)

The surgical technique shown is for illustrative purposes only. The technique(s) actually employed in each case will always depend upon the medical judgment of the surgeon exercised before and during surgery as to the best mode of treatment for each patient.

Please see the package insert for the complete list of indications, warnings, precautions, and other important medical information.



MLTDLIFST9 ©2009 Medtronic Sofamor Danek USA, Inc. All Rights Reserved. JRN9656-1.0-05/069

NUVA0000053