

Substitute for form 1449/PTO (Revised 07/2007)				<b>Complete if Known</b>	
				Application Number	12/460,139
<b>INFORMATION DISCLOSURE STATEMENT BY APPLICANT</b> <i>(Use as many sheets as necessary)</i>				Filing Date	July 14, 2009
				First Named Inventor	Brian T. Maguire
				Art Unit	3662
				Examiner Name	HULKA, James R.
				Attorney Docket Number	038495/369324
Sheet	15	of	16		

<b>OTHER DOCUMENTS</b>			
Examiner Initials*	Cite No.	Include name of the author (in CAPITAL LETTERS), title of the article (when appropriate), title of the item (book, magazine, journal, serial, symposium, catalog, etc.), date, page(s) , volume-issue number(s), publisher, city and/or country where published.	English Language Translation Attached
	243.	Lowrance HS-3DWN Transducer Assembly and Housing (Eagle IIID); August 1994	
	244.	Lowrance LCX-18C & LCX-19C Fish-finding Sonar & Mapping GPS; Operation Instructions; ©2002; 200 pages	
	245.	Lowrance Transducers Product Information; 1 page	
	246.	Navico Design Report of Raytheon Electronics Side Looker Transducer; 3/12/2010; 18 pages	
	247.	NOAA: Nautical Charting general information from public records; [Online]; Retrieved on 9/10/2010 from the Internet < URL: <a href="http://www.nauticalcharts.noaa.gov/csd/learn_hydroequip.html">http://www.nauticalcharts.noaa.gov/csd/learn_hydroequip.html</a> ; 2 pages; <a href="http://www.nauticalcharts.noaa.gov/csd/learn_hydroequip.html">http://www.nauticalcharts.noaa.gov/csd/learn_hydroequip.html</a> ; 1 page; <a href="http://www.nauticalcharts.noaa.gov/csd/PDBS.html">http://www.nauticalcharts.noaa.gov/csd/PDBS.html</a> ; 2 pages; <a href="http://www.nauticalcharts.noaa.gov/hsd/pub.html">http://www.nauticalcharts.noaa.gov/hsd/pub.html</a> ; 1 page; <a href="http://www.nauticalcharts.noaa.gov/hsd/fpm/fpm.htm">http://www.nauticalcharts.noaa.gov/hsd/fpm/fpm.htm</a> ; 1 page; <a href="http://www.ozcoasts.gov.au/geom_geol/toolkit/Tech_CA_sss.jsp">http://www.ozcoasts.gov.au/geom_geol/toolkit/Tech_CA_sss.jsp</a> ; 12 pages	
	248.	ONR Grant N66604-05-1-2983; Final Report; "Cooperative Autonomous Mobile Robots"; Retrieved from the Internet <URL: <a href="http://dodreports.com/pdf/ada463215.pdf">http://dodreports.com/pdf/ada463215.pdf</a> ; Post 2006	
	249.	Odom Echoscans™: For Sea Floor or Riverbed Surveys; Odom Hydrographic Systems; 04/26/2002	
	250.	Odom Hydrographic Systems ECHOSCAN Manual; Revision 1.11; 04/26/2002	
	251.	"Product Survey Side-Scan Sonar"; Hydro International Magazine; Volume 36; April 2004; pp. 36-39	
	252.	R/V QUICKSILVER; Hydrographic Survey Launch Bareboat or Crewed; F/V Norwind, Inc.	
	253.	R/V TANGAROA; Fact Sheet; Explore lost worlds of the deep; Norfanz Voyage; May 10 to June 8, 2003	
	254.	SeaBat 8101 Product Specification; 240kHz Multibeam Echo Sounder; ©1999 RESON Inc.; Version 4.0	

Examiner Signature	/James Hulka/	Date Considered	12/12/2011
--------------------	---------------	-----------------	------------

\*Examiner: Initial if reference considered, whether or not citation is in conformance with MPEP 609. Draw line through citation if not in conformance and not considered. Include copy of this form with next communication to applicant.

**SUBMITTED: NOVEMBER 15, 2011 RAY-1002**

351 of 737

**ALL REFERENCES CONSIDERED EXCEPT WHERE LINED THROUGH. /J.H./**

Substitute for form 1449/PTO (Revised 07/2007)  <b>INFORMATION DISCLOSURE                  STATEMENT BY APPLICANT</b> <i>(Use as many sheets as necessary)</i>			<b>Complete if Known</b>		
			Application Number	12/460,139	
			Filing Date	July 14, 2009	
			First Named Inventor	Brian T. Maguire	
			Art Unit	3662	
			Examiner Name	HULKA, James R.	
Sheet	16	of	16	Attorney Docket Number	038495/369324

<b>OTHER DOCUMENTS</b>			
Examiner Initials*	Cite No.	Include name of the author (in CAPITAL LETTERS), title of the article (when appropriate), title of the item (book, magazine, journal, serial, symposium, catalog, etc.), date, page(s), volume-issue number(s), publisher, city and/or country where published.	English Language Translation Attached
	255.	SIMRAD EA 500; Hydrographic Echo Sounder; Product Specifications; Revision: September 1993	
	256.	SonarBeam Underwater Surveying System Using T-150P tow-fish hull mounted; [Online]; [Retrieved on 2/12/2010 from the Internet <URL: <a href="http://dsmeu.en.ec21.com/Remotely_Operated_Sonar_Boat_System--618904_2479905.html">http://dsmeu.en.ec21.com/Remotely_Operated_Sonar_Boat_System--618904_2479905.html</a> ]; 4 pages; <a href="http://www.remtechnology.en.ec21.com/Side_Scan_Sonar_Remotely_Operated--2902034.html">http://www.remtechnology.en.ec21.com/Side_Scan_Sonar_Remotely_Operated--2902034.html</a> ]; 4 pages; [Retrieved on 2/16/2010 from the Internet <URL: <a href="http://dsmeu.en.ec21.com/Remotely_Operated_Sonar_Boat_System--618904_2479905.html">http://dsmeu.en.ec21.com/Remotely_Operated_Sonar_Boat_System--618904_2479905.html</a> ]; 4 pages; <a href="http://www.remtechnology.en.ec21.com/Side_Scan_Sonar_Remotely_Operated--2902230.html">http://www.remtechnology.en.ec21.com/Side_Scan_Sonar_Remotely_Operated--2902230.html</a> ]; 7 pages	
	257.	Starfish 450H; Sidescan System; Tritech International Limited; UK	
	258.	T297-00-01-01 Transducer housing outline drawing; Neptune Sonar Ltd.; ©2002	
	259.	TECHSONIC INDUSTRIES, INC.; "Mask, Acoustic"; Schematic, May 24, 1996	
	260.	TECHSONIC INDUSTRIES, INC.; "Element, 455 kHz"; Schematic, June 13, 1996	
	261.	"Transducers Quad Beam," Prior to August 2, 2003	
	262.	U-Tech Company Newsletter	
	263.	USACE, "Chapter 11, Acoustic Multibeam Survey Systems for Deep-Draft Navigation Projects," April 1, 2004	
	264.	Ultra III 3D Installation and Operation Instructions; EAGLE™; ©1994	
	265.	Westinghouse Publication; "Side-Scan Sonar Swiftly Surveys Subsurface Shellfish"; May 1970; 4 pages	
	266.	Sonar Theory and Applications; Excerpt from Imagenex Model 855 Color Imaging Sonar User's Manual; Imagenex Technology Corp.; Canada; 8 pages	


Examiner Signature	/James Hulka/	Date Considered	12/12/2011
-----------------------	---------------	--------------------	------------

\*Examiner: Initial if reference considered, whether or not citation is in conformance with MPEP 609. Draw line through citation if not in conformance and not considered. Include copy of this form with next communication to applicant.

**SUBMITTED: NOVEMBER 15, 2011** RAY-1002

352 of 737

ALL REFERENCES CONSIDERED EXCEPT WHERE LINED THROUGH. /J.H./

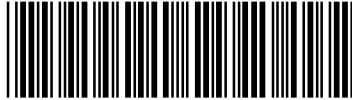
<b>Search Notes</b>  	<b>Application/Control No.</b>  12460139	<b>Applicant(s)/Patent Under Reexamination</b>  MAGUIRE, BRIAN T.
	<b>Examiner</b>  JAMES HULKA	<b>Art Unit</b>  3662

<b>SEARCHED</b>			
<b>Class</b>	<b>Subclass</b>	<b>Date</b>	<b>Examiner</b>
367	88	9/13/2011	JH

<b>SEARCH NOTES</b>		
<b>Search Notes</b>	<b>Date</b>	<b>Examiner</b>
EAST (Keyword and Class Limited)	9/13/2011	JH
PALM (Inventor Name)	9/13/2011	JH
Google (Keyword)	9/13/2011	JH

<b>INTERFERENCE SEARCH</b>			
<b>Class</b>	<b>Subclass</b>	<b>Date</b>	<b>Examiner</b>

--	--

<b>Index of Claims</b>  	<b>Application/Control No.</b>  12460139	<b>Applicant(s)/Patent Under Reexamination</b>  MAGUIRE, BRIAN T.
	<b>Examiner</b>  JAMES HULKA	<b>Art Unit</b>  3662

✓	<b>Rejected</b>
=	<b>Allowed</b>

-	<b>Cancelled</b>
÷	<b>Restricted</b>

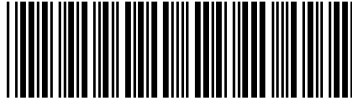
N	<b>Non-Elected</b>
I	<b>Interference</b>

A	<b>Appeal</b>
O	<b>Objected</b>

Claims renumbered in the same order as presented by applicant
  CPA
  T.D.
  R.1.47

CLAIM		DATE							
Final	Original	07/26/2011	09/13/2011	12/08/2011					
	1	÷	N	-					
	2	÷	N	-					
	3	÷	N	-					
	4	÷	N	-					
	5	÷	N	-					
	6	÷	N	-					
	7	÷	N	-					
	8	÷	N	-					
	9	÷	N	-					
	10	÷	N	-					
	11	÷	N	-					
	12	÷	N	-					
	13	÷	N	-					
	14	÷	N	-					
	15	÷	N	-					
	16	÷	N	-					
	17	÷	N	-					
	18	÷	N	-					
	19	÷	N	-					
	20	÷	N	-					
	21	÷	N	-					
	22	÷	N	-					
	23	÷	N	-					
	24	÷	N	-					
	25	÷	N	-					
	26	÷	N	-					
	27	÷	N	-					
	28	÷	N	-					
	29	÷	N	-					
	30	÷	N	-					
	31	÷	N	-					
	32	÷	N	-					
	33	÷	N	-					
	34	÷	N	-					
	35	÷	N	-					
	36	÷	N	-					



<b>Index of Claims</b>  	<b>Application/Control No.</b> 12460139	<b>Applicant(s)/Patent Under Reexamination</b> MAGUIRE, BRIAN T.
	<b>Examiner</b> JAMES HULKA	<b>Art Unit</b> 3662

✓	<b>Rejected</b>
=	<b>Allowed</b>

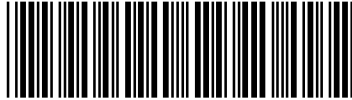
-	<b>Cancelled</b>
÷	<b>Restricted</b>

N	<b>Non-Elected</b>
I	<b>Interference</b>

A	<b>Appeal</b>
O	<b>Objected</b>

Claims renumbered in the same order as presented by applicant
  CPA
  T.D.
  R.1.47

CLAIM		DATE							
Final	Original	07/26/2011	09/13/2011	12/08/2011					
	37	÷	N	-					
	38	÷	N	-					
	39	÷	N	-					
	40	÷	N	-					
	41	÷	N	-					
	42	÷	N	-					
	43	÷	N	-					
	44	÷	N	-					
	45	÷	N	-					
	46	÷	N	-					
	47	÷	N	-					
	48	÷	N	-					
	49	÷	N	-					
	50	÷	N	-					
	51	÷	N	-					
	52	÷	N	-					
	53	÷	N	-					
	54	÷	N	-					
	55	÷	N	-					
	56	÷	N	-					
	57	÷	✓	✓					
	58	÷	✓	✓					
	59	÷	✓	✓					
	60	÷	✓	✓					
	61	÷	✓	✓					
	62	÷	✓	✓					
	63	÷	✓	✓					
	64	÷	✓	✓					
	65	÷	✓	✓					
	66	÷	✓	✓					
	67	÷	✓	✓					
	68	÷	✓	✓					
	69	÷	✓	✓					
	70	÷	✓	✓					
	71	÷	✓	✓					
	72	÷	✓	✓					

<b>Index of Claims</b>  	<b>Application/Control No.</b>  12460139	<b>Applicant(s)/Patent Under Reexamination</b>  MAGUIRE, BRIAN T.
	<b>Examiner</b>  JAMES HULKA	<b>Art Unit</b>  3662

✓	<b>Rejected</b>
=	<b>Allowed</b>

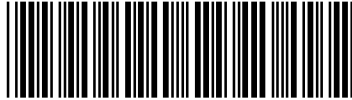
-	<b>Cancelled</b>
÷	<b>Restricted</b>

N	<b>Non-Elected</b>
I	<b>Interference</b>

A	<b>Appeal</b>
O	<b>Objected</b>

Claims renumbered in the same order as presented by applicant
  CPA
  T.D.
  R.1.47

CLAIM		DATE							
Final	Original	07/26/2011	09/13/2011	12/08/2011					
	73	÷	✓	✓					
	74	÷	✓	✓					
	75	÷	✓	✓					
	76	÷	✓	✓					
	77	÷	✓	✓					
	78	÷	✓	✓					
	79	÷	✓	✓					
	80	÷	✓	✓					
	81	÷	✓	✓					
	82	÷	✓	✓					
	83	÷	✓	✓					
	84	÷	✓	✓					
	85	÷	✓	-					
	86	÷	✓	✓					
	87	÷	✓	-					
	88	÷	✓	✓					
	89	÷	✓	✓					
	90	÷	✓	✓					
	91	÷	✓	✓					
	92	÷	✓	✓					
	93	÷	✓	✓					
	94	÷	✓	✓					
	95	÷	✓	✓					
	96	÷	✓	✓					
	97	÷	✓	✓					
	98	÷	✓	✓					
	99	÷	✓	✓					
	100			✓					
	101			✓					
	102			✓					
	103			✓					
	104			✓					
	105			✓					
	106			✓					
	107			✓					
	108			✓					

<b>Index of Claims</b>  	<b>Application/Control No.</b>  12460139	<b>Applicant(s)/Patent Under Reexamination</b>  MAGUIRE, BRIAN T.
	<b>Examiner</b>  JAMES HULKA	<b>Art Unit</b>  3662

✓	<b>Rejected</b>
=	<b>Allowed</b>

-	<b>Cancelled</b>
÷	<b>Restricted</b>

N	<b>Non-Elected</b>
I	<b>Interference</b>

A	<b>Appeal</b>
O	<b>Objected</b>

Claims renumbered in the same order as presented by applicant
  CPA
  T.D.
  R.1.47

CLAIM		DATE							
Final	Original	07/26/2011	09/13/2011	12/08/2011					
	109			✓					
	110			✓					
	111			✓					
	112			✓					
	113			✓					
	114			✓					
	115			✓					
	116			✓					
	117			✓					
	118			✓					
	119			✓					
	120			✓					
	121			✓					
	122			✓					
	123			✓					
	124			✓					
	125			✓					
	126			-					
	127			✓					
	128			✓					
	129			✓					
	130			✓					
	131			✓					
	132			-					
	133			-					
	134			✓					
	135			-					
	136			-					
	137			-					

## EAST Search History

## EAST Search History (Prior Art)

Ref #	Hits	Search Query	DBs	Default Operator	Plurals	Time Stamp
S1	18	US-20040184351-\$.DID. OR US-20050043619-\$.DID. OR US-20050099887-\$.DID. OR US-20060002232-\$.DID. OR US-20070025183-\$.DID. OR US-20070091723-\$.DID. OR US-1316138-\$.DID. OR JP-57046173-\$.DID. OR JP-61116678-\$.DID. OR JP-4357487-\$.DID. OR WO-9815846-\$.DID.	US-PGPUB; USPAT; USOCR; FPRS; EPO; JPO; DERWENT; IBM_TDB	OR	OFF	2011/12/06 10:52
S2	123	Stiner.in.	US-PGPUB; USPAT; USOCR; FPRS; EPO; JPO; DERWENT; IBM_TDB	OR	OFF	2011/12/06 10:55
S3	0	pd= "19920922"	US-PGPUB; USPAT; USOCR; FPRS; EPO; JPO; DERWENT; IBM_TDB	OR	OFF	2011/12/06 10:55
S4	7212	"19920922".pd.	US-PGPUB; USPAT; USOCR; FPRS; EPO; JPO; DERWENT; IBM_TDB	OR	OFF	2011/12/06 10:57
S5	9713024	(US-5,850,372 US-5,930,199 US-5,991,239 US-6,002,644 US-6,084,827 US-6,215,730 US-6,335,905 US-6,421,299 US-6,449,215 US-6,537,224 US-6,606,958 US-6,678,403 US-6,738,311 US-6,842,401 US-6,941,226 US-6,980,688 US-7,236,427 US-7,355,924 US-7,405,999 US-7,542,376 US-7,652,952 US-7,710,825 US-7,729,203 US-7,755,974 US-2003/0202426 A S1).pn.	US-PGPUB; USPAT; USOCR; FPRS; EPO; JPO; DERWENT; IBM_TDB	OR	OFF	2011/12/06 11:00
S6	56	("5850372" "5930199" "5991239" "6002644" "6084827" "6215730" "6335905" "6421299" "6449215" "6537224" "6606958" "6678403" "6738311" "6842401" "6941226" "6980688" "7236427" "7355924" "7405999" "7542376" "7652952" "7710825" "7729203" "7755974" "20030202426").pn.	US-PGPUB; USPAT; USOCR; FPRS; EPO; JPO; DERWENT; IBM_TDB	OR	OFF	2011/12/06 11:03
S7	25	("5850372" "5930199" "5991239"	US-PGPUB;	OR	OFF	2011/12/06

		"6002644" "6084827" "6215730" "6335905" "6421299" "6449215" "6537224" "6606958" "6678403" "6738311" "6842401" "6941226" "6980688" "7236427" "7355924" "7405999" "7542376" "7652952" "7710825" "7729203" "7755974" "20030202426").pn.	USPAT			11:04
S8	50	("5200931" "5214744" "5241314" "5245587" "5243567" "5257241" "5260912" "5303208" "5376933" "5390152" "5412618" "5438552" "5442358" "5455806" "5493619" "5515337" "5537366" "5546356" "5561641" "5574700" "5596549" "5602801" "5612928" "5694372" "5805528").pn.	US-PGPUB; USPAT; USOCR; FPRS; EPO; JPO; DERWENT; IBM_TDB	OR	OFF	2011/12/06 11:07
S9	58	("4635240" "4641290" "4642801" "4751645" "4774837" "4796238" "4802148" "4815045" "4855961" "4879697" "4907208" "4912685" "4924448" "4939700" "4958330" "4970700" "4975887" "4982924" "5033029" "5109364" "5113377" "5142502" "5155706" "5182732" "5184330").pn.	US-PGPUB; USPAT; USOCR; FPRS; EPO; JPO; DERWENT; IBM_TDB	OR	OFF	2011/12/06 11:11
S10	58	("4635240" "4641290" "4642801" "4751645" "4774837" "4796238" "4802148" "4815045" "4855961" "4879697" "4907208" "4912685" "4924448" "4939700" "4958330" "4970700" "4975887" "4982924" "5033029" "5109364" "5113377" "5142502" "5155706" "5182732" "5184330").pn.	US-PGPUB; USPAT; USOCR; FPRS; EPO; JPO; DERWENT; IBM_TDB	OR	OFF	2011/12/06 11:13
S11	80	("3953828" "3964424" "3967234" "4030096" "4047148" "4052693" "4063212" "4068209" "4075599" "4184210" "4197591" "4198702" "4199746" "4200922" "4204281" "4207620" "4216537" "4232380" "4247923" "4262344" "4287578" "4422166" "4456210" "4493064" "4538249").pn.	US-PGPUB; USPAT; USOCR; FPRS; EPO; JPO; DERWENT; IBM_TDB	OR	OFF	2011/12/06 11:15
S12	81	("1823329" "2416338" "3005973" "3090030" "3142032" "3144631" "3296579" "3359537" "3381264" "3451038" "3458854" "3484737" "3553638" "3585578" "3585579" "3618006" "3624596" "3716824" "3742436" "3757287" "3895339" "3895340" "3898608" "3949348" "3950723").pn.	US-PGPUB; USPAT; USOCR; FPRS; EPO; JPO; DERWENT; IBM_TDB	OR	OFF	2011/12/06 11:18
S13	136	(US-20070025183-\$ or US- 20070091723-\$ or US-20060002232-\$ or US-20050099887-\$ or US- 20050043619-\$ or US-20040184351-\$ or US-20030202426-\$).did. or (US- D329616-\$ or US-D329615-\$ or US- 7755974-\$ or US-7729203-\$ or US- 7710825-\$ or US-7652952-\$ or US- 7542376-\$ or US-7405999-\$ or US-	US-PGPUB; USPAT; JPO; DERWENT	OR	OFF	2011/12/06 11:19

		7355924-\$ or US-7236427-\$ or US-6980688-\$ or US-6941226-\$ or US-6842401-\$ or US-6738311-\$ or US-6678403-\$ or US-6606958-\$ or US-6537224-\$ or US-6449215-\$ or US-6421299-\$ or US-6335905-\$ or US-6215730-\$ or US-6002644-\$ or US-6084827-\$ or US-5991239-\$ or US-5930199-\$ or US-5850372-\$.did. or (US-5200931-\$ or US-5214744-\$ or US-5241314-\$ or US-5243567-\$ or US-5245587-\$ or US-5257241-\$ or US-5260912-\$ or US-5303208-\$ or US-5376933-\$ or US-5390152-\$ or US-5412618-\$ or US-5438552-\$ or US-5442358-\$ or US-5455806-\$ or US-5493619-\$ or US-5515337-\$ or US-5537366-\$ or US-5546356-\$ or US-5561641-\$ or US-5574700-\$ or US-5596549-\$ or US-5602801-\$ or US-5612928-\$ or US-5694372-\$ or US-5805528-\$ or US-5184330-\$ or US-5182732-\$.did. or (US-5142502-\$ or US-5113377-\$ or US-5109364-\$ or US-5033029-\$ or US-4982924-\$ or US-4975887-\$ or US-4970700-\$ or US-4958330-\$ or US-4939700-\$ or US-4924448-\$ or US-4912685-\$ or US-4907208-\$ or US-4879697-\$ or US-4855961-\$ or US-4815045-\$ or US-4802148-\$ or US-4796238-\$ or US-4774837-\$ or US-4751645-\$ or US-4642801-\$ or US-4641290-\$ or US-4635240-\$ or US-5155706-\$ or US-4538249-\$ or US-4493064-\$ or US-4456210-\$ or US-4422166-\$.did. or (US-4287578-\$ or US-4262344-\$ or US-4247923-\$ or US-4232380-\$ or US-4216537-\$ or US-4207620-\$ or US-4204281-\$ or US-4200922-\$ or US-4199746-\$ or US-4198702-\$ or US-4197591-\$ or US-4184210-\$ or US-4075599-\$ or US-4068209-\$ or US-4063212-\$ or US-4052693-\$ or US-4047148-\$ or US-4030096-\$ or US-3967234-\$ or US-3964424-\$ or US-3953828-\$ or US-3950723-\$ or US-3949348-\$ or US-3898608-\$ or US-3895340-\$ or US-3895339-\$ or US-3757287-\$.did. or (US-3742436-\$ or US-3716824-\$ or US-3624596-\$ or US-3618006-\$ or US-3585579-\$ or US-3585578-\$ or US-3553638-\$ or US-3484737-\$ or US-3458854-\$ or US-3451038-\$ or US-3381264-\$ or US-3359537-\$ or US-3296579-\$ or US-3144631-\$ or US-3142032-\$ or US-3090030-\$ or US-3005973-\$ or US-2416338-\$ or US-1823329-\$.did. or (JP-61116678-\$ or JP-57046173-\$.did. or (WO-9815846-\$.did.				
S14	102	S13 and sonar	US-PGPUB; USPAT; USOCR;	OR	OFF	2011/12/06 11:20

			FPRS; EPO; JPO; DERWENT; IBM_TDB			
S15	60	S13 and sonar and (down\$4)	US-PGPUB; USPAT; USOCR; FPRS; EPO; JPO; DERWENT; IBM_TDB	OR	OFF	2011/12/06 11:20
S16	59	S13 and sonar and (down\$4) and line\$4	US-PGPUB; USPAT; USOCR; FPRS; EPO; JPO; DERWENT; IBM_TDB	OR	OFF	2011/12/06 11:20
S17	43	S13 and line\$3 near4 transduc\$4	US-PGPUB; USPAT; USOCR; FPRS; EPO; JPO; DERWENT; IBM_TDB	OR	OFF	2011/12/06 11:25
S18	23	S13 and line\$3 near4 transduc\$4 and perpendicular	US-PGPUB; USPAT; USOCR; FPRS; EPO; JPO; DERWENT; IBM_TDB	OR	OFF	2011/12/06 11:25
S19	16	S13 and line\$3 near4 transduc\$4 and perpendicular and (long\$2 or longitud\$4)	US-PGPUB; USPAT; USOCR; FPRS; EPO; JPO; DERWENT; IBM_TDB	OR	OFF	2011/12/06 11:25
S20	0	S13 and line\$3 near4 transduc\$4 and downscan\$4	US-PGPUB; USPAT; USOCR; FPRS; EPO; JPO; DERWENT; IBM_TDB	OR	OFF	2011/12/06 11:26
S22	136	(US-20070025183-\$ or US- 20070091723-\$ or US-20060002232-\$ or US-20050099887-\$ or US- 20050043619-\$ or US-20040184351-\$ or US-20030202426-\$).did. or (US- D329616-\$ or US-D329615-\$ or US- 7755974-\$ or US-7729203-\$ or US- 7710825-\$ or US-7652952-\$ or US- 7542376-\$ or US-7405999-\$ or US- 7355924-\$ or US-7236427-\$ or US- 6980688-\$ or US-6941226-\$ or US- 6842401-\$ or US-6738311-\$ or US- 6678403-\$ or US-6606958-\$ or US- 6537224-\$ or US-6449215-\$ or US- 6421299-\$ or US-6335905-\$ or US- 6215730-\$ or US-6002644-\$ or US-	US-PGPUB; USPAT; JPO; DERWENT	OR	OFF	2011/12/06 17:50

		6084827-\$ or US-5991239-\$ or US-5930199-\$ or US-5850372-\$).did. or (US-5200931-\$ or US-5214744-\$ or US-5241314-\$ or US-5243567-\$ or US-5245587-\$ or US-5257241-\$ or US-5260912-\$ or US-5303208-\$ or US-5376933-\$ or US-5390152-\$ or US-5412618-\$ or US-5438552-\$ or US-5442358-\$ or US-5455806-\$ or US-5493619-\$ or US-5515337-\$ or US-5537366-\$ or US-5546356-\$ or US-5561641-\$ or US-5574700-\$ or US-5596549-\$ or US-5602801-\$ or US-5612928-\$ or US-5694372-\$ or US-5805528-\$ or US-5184330-\$ or US-5182732-\$).did. or (US-5142502-\$ or US-5113377-\$ or US-5109364-\$ or US-5033029-\$ or US-4982924-\$ or US-4975887-\$ or US-4970700-\$ or US-4958330-\$ or US-4939700-\$ or US-4924448-\$ or US-4912685-\$ or US-4907208-\$ or US-4879697-\$ or US-4855961-\$ or US-4815045-\$ or US-4802148-\$ or US-4796238-\$ or US-4774837-\$ or US-4751645-\$ or US-4642801-\$ or US-4641290-\$ or US-4635240-\$ or US-5155706-\$ or US-4538249-\$ or US-4493064-\$ or US-4456210-\$ or US-4422166-\$).did. or (US-4287578-\$ or US-4262344-\$ or US-4247923-\$ or US-4232380-\$ or US-4216537-\$ or US-4207620-\$ or US-4204281-\$ or US-4200922-\$ or US-4199746-\$ or US-4198702-\$ or US-4197591-\$ or US-4184210-\$ or US-4075599-\$ or US-4068209-\$ or US-4063212-\$ or US-4052693-\$ or US-4047148-\$ or US-4030096-\$ or US-3967234-\$ or US-3964424-\$ or US-3953828-\$ or US-3950723-\$ or US-3949348-\$ or US-3898608-\$ or US-3895340-\$ or US-3895339-\$ or US-3757287-\$).did. or (US-3742436-\$ or US-3716824-\$ or US-3624596-\$ or US-3618006-\$ or US-3585579-\$ or US-3585578-\$ or US-3553638-\$ or US-3484737-\$ or US-3458854-\$ or US-3451038-\$ or US-3381264-\$ or US-3359537-\$ or US-3296579-\$ or US-3144631-\$ or US-3142032-\$ or US-3090030-\$ or US-3005973-\$ or US-2416338-\$ or US-1823329-\$).did. or (JP-61116678-\$ or JP-57046173-\$).did. or (WO-9815846-\$).did.				
S23	3993773	S22 and image\$2 or display\$2	US-PGPUB; USPAT; USOCR; FPRS; EPO; JPO; DERWENT; IBM_TDB	OR	OFF	2011/12/06 17:50
S24	103	S22 and (image\$2 or display\$2)	US-PGPUB; USPAT; USOCR;	OR	OFF	2011/12/06 17:51



			FPRS; EPO; JPO; DERWENT; IBM_TDB			
S25	29	S22 and ((image\$2 or display\$2) same combin\$4)	US-PGPUB; USPAT; USOCR; FPRS; EPO; JPO; DERWENT; IBM_TDB	OR	OFF	2011/12/06 17:51
S26	1	(12/319604).APP.	US-PGPUB; USOCR	OR	OFF	2011/12/06 17:52
S27	1	(12/319604).APP.	US-PGPUB; USOCR	OR	OFF	2011/12/06 17:53
S28	1	(11/195107).APP.	US-PGPUB; USOCR	OR	OFF	2011/12/06 17:53
S30	136	(US-20070025183-\$ or US-20070091723-\$ or US-20060002232-\$ or US-20050099887-\$ or US-20050043619-\$ or US-20040184351-\$ or US-20030202426-\$).did. or (US-D329616-\$ or US-D329615-\$ or US-7755974-\$ or US-7729203-\$ or US-7710825-\$ or US-7652952-\$ or US-7542376-\$ or US-7405999-\$ or US-7355924-\$ or US-7236427-\$ or US-6980688-\$ or US-6941226-\$ or US-6842401-\$ or US-6738311-\$ or US-6678403-\$ or US-6606958-\$ or US-6537224-\$ or US-6449215-\$ or US-6421299-\$ or US-6335905-\$ or US-6215730-\$ or US-6002644-\$ or US-6084827-\$ or US-5991239-\$ or US-5930199-\$ or US-5850372-\$).did. or (US-5200931-\$ or US-5214744-\$ or US-5241314-\$ or US-5243567-\$ or US-5245587-\$ or US-5257241-\$ or US-5260912-\$ or US-5303208-\$ or US-5376933-\$ or US-5390152-\$ or US-5412618-\$ or US-5438552-\$ or US-5442358-\$ or US-5455806-\$ or US-5493619-\$ or US-5515337-\$ or US-5537366-\$ or US-5546356-\$ or US-5561641-\$ or US-5574700-\$ or US-5596549-\$ or US-5602801-\$ or US-5612928-\$ or US-5694372-\$ or US-5805528-\$ or US-5184330-\$ or US-5182732-\$).did. or (US-5142502-\$ or US-5113377-\$ or US-5109364-\$ or US-5033029-\$ or US-4982924-\$ or US-4975887-\$ or US-4970700-\$ or US-4958330-\$ or US-4939700-\$ or US-4924448-\$ or US-4912685-\$ or US-4907208-\$ or US-4879697-\$ or US-4855961-\$ or US-4815045-\$ or US-4802148-\$ or US-4796238-\$ or US-4774837-\$ or US-4751645-\$ or US-4642801-\$ or US-4641290-\$ or US-4635240-\$ or US-5155706-\$ or US-4538249-\$ or US-4493064-\$ or US-4456210-\$ or US-4422166-\$).did. or	US-PGPUB; USPAT; JPO; DERWENT	OR	OFF	2011/12/06 19:04

		(US-4287578-\$ or US-4262344-\$ or US-4247923-\$ or US-4232380-\$ or US-4216537-\$ or US-4207620-\$ or US-4204281-\$ or US-4200922-\$ or US-4199746-\$ or US-4198702-\$ or US-4197591-\$ or US-4184210-\$ or US-4075599-\$ or US-4068209-\$ or US-4063212-\$ or US-4052693-\$ or US-4047148-\$ or US-4030096-\$ or US-3967234-\$ or US-3964424-\$ or US-3953828-\$ or US-3950723-\$ or US-3949348-\$ or US-3898608-\$ or US-3895340-\$ or US-3895339-\$ or US-3757287-\$).did. or (US-3742436-\$ or US-3716824-\$ or US-3624596-\$ or US-3618006-\$ or US-3585579-\$ or US-3585578-\$ or US-3553638-\$ or US-3484737-\$ or US-3458854-\$ or US-3451038-\$ or US-3381264-\$ or US-3359537-\$ or US-3296579-\$ or US-3144631-\$ or US-3142032-\$ or US-3090030-\$ or US-3005973-\$ or US-2416338-\$ or US-1823329-\$).did. or (JP-61116678-\$ or JP-57046173-\$).did. or (WO-9815846-\$).did.				
S31	37	S30 and ((image\$2 or display\$2) same (combin\$4 or overlap\$4))	US-PGPUB; USPAT; USOCR; FPRS; EPO; JPO; DERWENT; IBM_TDB	OR	OFF	2011/12/06 19:04
S32	137	(US-20070025183-\$ or US-20070091723-\$ or US-20060002232-\$ or US-20050099887-\$ or US-20050043619-\$ or US-20040184351-\$ or US-20030202426-\$ or US-20060023570-\$).did. or (US-D329616-\$ or US-D329615-\$ or US-7755974-\$ or US-7729203-\$ or US-7710825-\$ or US-7652952-\$ or US-7542376-\$ or US-7405999-\$ or US-7355924-\$ or US-7236427-\$ or US-6980688-\$ or US-6941226-\$ or US-6842401-\$ or US-6738311-\$ or US-6678403-\$ or US-6606958-\$ or US-6537224-\$ or US-6449215-\$ or US-6421299-\$ or US-6335905-\$ or US-6215730-\$ or US-6002644-\$ or US-6084827-\$ or US-5991239-\$ or US-5930199-\$ or US-5850372-\$).did. or (US-5200931-\$ or US-5214744-\$ or US-5241314-\$ or US-5243567-\$ or US-5245587-\$ or US-5257241-\$ or US-5260912-\$ or US-5303208-\$ or US-5376933-\$ or US-5390152-\$ or US-5412618-\$ or US-5438552-\$ or US-5442358-\$ or US-5455806-\$ or US-5493619-\$ or US-5515337-\$ or US-5537366-\$ or US-5546356-\$ or US-5561641-\$ or US-5574700-\$ or US-5596549-\$ or US-5602801-\$ or US-5612928-\$ or US-5694372-\$ or US-5805528-\$ or US-5184330-\$ or US-5182732-\$).did. or	US-PGPUB; USPAT; JPO; DERWENT	OR	OFF	2011/12/06 19:04

		(US-5142502-\$ or US-5113377-\$ or US-5109364-\$ or US-5033029-\$ or US-4982924-\$ or US-4975887-\$ or US-4970700-\$ or US-4958330-\$ or US-4939700-\$ or US-4924448-\$ or US-4912685-\$ or US-4907208-\$ or US-4879697-\$ or US-4855961-\$ or US-4815045-\$ or US-4802148-\$ or US-4796238-\$ or US-4774837-\$ or US-4751645-\$ or US-4642801-\$ or US-4641290-\$ or US-4635240-\$ or US-5155706-\$ or US-4538249-\$ or US-4493064-\$ or US-4456210-\$ or US-4422166-\$).did. or (US-4287578-\$ or US-4262344-\$ or US-4247923-\$ or US-4232380-\$ or US-4216537-\$ or US-4207620-\$ or US-4204281-\$ or US-4200922-\$ or US-4199746-\$ or US-4198702-\$ or US-4197591-\$ or US-4184210-\$ or US-4075599-\$ or US-4068209-\$ or US-4063212-\$ or US-4052693-\$ or US-4047148-\$ or US-4030096-\$ or US-3967234-\$ or US-3964424-\$ or US-3953828-\$ or US-3950723-\$ or US-3949348-\$ or US-3898608-\$ or US-3895340-\$ or US-3895339-\$ or US-3757287-\$).did. or (US-3742436-\$ or US-3716824-\$ or US-3624596-\$ or US-3618006-\$ or US-3585579-\$ or US-3585578-\$ or US-3553638-\$ or US-3484737-\$ or US-3458854-\$ or US-3451038-\$ or US-3381264-\$ or US-3359537-\$ or US-3296579-\$ or US-3144631-\$ or US-3142032-\$ or US-3090030-\$ or US-3005973-\$ or US-2416338-\$ or US-1823329-\$).did. or (JP-61116678-\$ or JP-57046173-\$).did. or (WO-9815846-\$).did.				
S33	37	S32 and ((image\$2 or display\$2) same (combin\$4 or overlap\$4))	US-PGPUB; USPAT; USOCR; FPRS; EPO; JPO; DERWENT; IBM_TDB	OR	OFF	2011/12/06 19:05
S35	9	(US-20070025183-\$ or US-20050099887-\$ or US-20060023570-\$).did. or (US-7755974-\$ or US-7729203-\$ or US-7710825-\$ or US-7652952-\$ or US-5991239-\$ or US-5805528-\$).did.	US-PGPUB; USPAT	OR	OFF	2011/12/07 14:44
S36	7	S35 and computer\$2	US-PGPUB; USPAT; USOCR; FPRS; EPO; JPO; DERWENT; IBM_TDB	OR	OFF	2011/12/07 14:44
S37	0	S35 and computer\$2 same medi\$2	US-PGPUB; USPAT; USOCR; FPRS;	OR	OFF	2011/12/07 14:44

			EPO; JPO; DERWENT; IBM_TDB			
S38	5	S35 and computer\$2 same (medi\$2 or software or program\$2 or memory\$2)	US-PGPUB; USPAT; USOCR; FPRS; EPO; JPO; DERWENT; IBM_TDB	OR	OFF	2011/12/07 14:45
S39	137	(US-20070025183-\$ or US-20070091723-\$ or US-20060002232-\$ or US-20050099887-\$ or US-20050043619-\$ or US-20040184351-\$ or US-20030202426-\$ or US-20060023570-\$).did. or (US-D329616-\$ or US-D329615-\$ or US-7755974-\$ or US-7729203-\$ or US-7710825-\$ or US-7652952-\$ or US-7542376-\$ or US-7405999-\$ or US-7355924-\$ or US-7236427-\$ or US-6980688-\$ or US-6941226-\$ or US-6842401-\$ or US-6738311-\$ or US-6678403-\$ or US-6606958-\$ or US-6537224-\$ or US-6449215-\$ or US-6421299-\$ or US-6335905-\$ or US-6215730-\$ or US-6002644-\$ or US-6084827-\$ or US-5991239-\$ or US-5930199-\$ or US-5850372-\$).did. or (US-5200931-\$ or US-5214744-\$ or US-5241314-\$ or US-5243567-\$ or US-5245587-\$ or US-5257241-\$ or US-5260912-\$ or US-5303208-\$ or US-5376933-\$ or US-5390152-\$ or US-5412618-\$ or US-5438552-\$ or US-5442358-\$ or US-5455806-\$ or US-5493619-\$ or US-5515337-\$ or US-5537366-\$ or US-5546356-\$ or US-5561641-\$ or US-5574700-\$ or US-5596549-\$ or US-5602801-\$ or US-5612928-\$ or US-5694372-\$ or US-5805528-\$ or US-5184330-\$ or US-5182732-\$).did. or (US-5142502-\$ or US-5113377-\$ or US-5109364-\$ or US-5033029-\$ or US-4982924-\$ or US-4975887-\$ or US-4970700-\$ or US-4958330-\$ or US-4939700-\$ or US-4924448-\$ or US-4912685-\$ or US-4907208-\$ or US-4879697-\$ or US-4855961-\$ or US-4815045-\$ or US-4802148-\$ or US-4796238-\$ or US-4774837-\$ or US-4751645-\$ or US-4642801-\$ or US-4641290-\$ or US-4635240-\$ or US-5155706-\$ or US-4538249-\$ or US-4493064-\$ or US-4456210-\$ or US-4422166-\$).did. or (US-4287578-\$ or US-4262344-\$ or US-4247923-\$ or US-4232380-\$ or US-4216537-\$ or US-4207620-\$ or US-4204281-\$ or US-4200922-\$ or US-4199746-\$ or US-4198702-\$ or US-4197591-\$ or US-4184210-\$ or US-4075599-\$ or US-4068209-\$ or US-4063212-\$ or US-4052693-\$ or US-4047148-\$ or US-	US-PGPUB; USPAT; JPO; DERWENT	OR	OFF	2011/12/07 14:59

		4030096-\$ or US-3967234-\$ or US-3964424-\$ or US-3953828-\$ or US-3950723-\$ or US-3949348-\$ or US-3898608-\$ or US-3895340-\$ or US-3895339-\$ or US-3757287-\$).did. or (US-3742436-\$ or US-3716824-\$ or US-3624596-\$ or US-3618006-\$ or US-3585579-\$ or US-3585578-\$ or US-3553638-\$ or US-3484737-\$ or US-3458854-\$ or US-3451038-\$ or US-3381264-\$ or US-3359537-\$ or US-3296579-\$ or US-3144631-\$ or US-3142032-\$ or US-3090030-\$ or US-3005973-\$ or US-2416338-\$ or US-1823329-\$).did. or (JP-61116678-\$ or JP-57046173-\$).did. or (WO-9815846-\$).did.				
S40	0	S39 and (weight\$3 near5 factor\$4)	US-PGPUB; USPAT; USOCR; FPRS; EPO; JPO; DERWENT; IBM_TDB	OR	OFF	2011/12/07 14:59
S41	0	S39 and (weight\$3 same factor\$4)	US-PGPUB; USPAT; USOCR; FPRS; EPO; JPO; DERWENT; IBM_TDB	OR	OFF	2011/12/07 14:59
S42	12	S39 and (weight\$3 and factor\$4)	US-PGPUB; USPAT; USOCR; FPRS; EPO; JPO; DERWENT; IBM_TDB	OR	OFF	2011/12/07 14:59
S43	12	S39 and (weight\$3 same data)	US-PGPUB; USPAT; USOCR; FPRS; EPO; JPO; DERWENT; IBM_TDB	OR	OFF	2011/12/07 15:00
S44	4	S39 and (weight\$3 same data same (circular\$2 or conical\$2 or bottom))	US-PGPUB; USPAT; USOCR; FPRS; EPO; JPO; DERWENT; IBM_TDB	OR	OFF	2011/12/07 15:03
S45	32	(sort\$4 near4 data near5 column\$4) and ((display\$4 or render\$4) near5 data same select\$4 same averag\$4)	US-PGPUB; USPAT; USOCR; FPRS; EPO; JPO; DERWENT; IBM_TDB	OR	OFF	2011/12/07 18:25
S46	7	(sort\$4 near4 data near5 column\$4) and ((display\$4 or render\$4) near5 data same sonar)	US-PGPUB; USPAT; USOCR;	OR	OFF	2011/12/07 18:26

			FPRS; EPO; JPO; DERWENT; IBM_TDB			
S47	255	(sort\$4 near4 data near5 column\$4) and ((display\$4 or render\$4) near5 select\$3 near5 data)	US-PGPUB; USPAT; USOCR; FPRS; EPO; JPO; DERWENT; IBM_TDB	OR	OFF	2011/12/07 18:27
S48	27	(sort\$4 near4 data near5 column\$4) and ((display\$4 or render\$4) near5 select\$3 near5 image\$3)	US-PGPUB; USPAT; USOCR; FPRS; EPO; JPO; DERWENT; IBM_TDB	OR	OFF	2011/12/07 18:28
S49	139	(US-20070025183-\$ or US- 20070091723-\$ or US-20060002232-\$ or US-20050099887-\$ or US- 20050043619-\$ or US-20040184351-\$ or US-20030202426-\$ or US- 20060023570-\$ or US-20020071029-\$ or US-20050216487-\$).did. or (US- D329616-\$ or US-D329615-\$ or US- 7755974-\$ or US-7729203-\$ or US- 7710825-\$ or US-7652952-\$ or US- 7542376-\$ or US-7405999-\$ or US- 7355924-\$ or US-7236427-\$ or US- 6980688-\$ or US-6941226-\$ or US- 6842401-\$ or US-6738311-\$ or US- 6678403-\$ or US-6606958-\$ or US- 6537224-\$ or US-6449215-\$ or US- 6421299-\$ or US-6335905-\$ or US- 6215730-\$ or US-6002644-\$ or US- 6084827-\$ or US-5991239-\$ or US- 5930199-\$ or US-5850372-\$).did. or (US-5200931-\$ or US-5214744-\$ or US-5241314-\$ or US-5243567-\$ or US- 5245587-\$ or US-5257241-\$ or US- 5260912-\$ or US-5303208-\$ or US- 5376933-\$ or US-5390152-\$ or US- 5412618-\$ or US-5438552-\$ or US- 5442358-\$ or US-5455806-\$ or US- 5493619-\$ or US-5515337-\$ or US- 5537366-\$ or US-5546356-\$ or US- 5561641-\$ or US-5574700-\$ or US- 5596549-\$ or US-5602801-\$ or US- 5612928-\$ or US-5694372-\$ or US- 5805528-\$ or US-5184330-\$ or US- 5182732-\$).did. or (US-5142502-\$ or US-5113377-\$ or US-5109364-\$ or US- 5033029-\$ or US-4982924-\$ or US- 4975887-\$ or US-4970700-\$ or US- 4958330-\$ or US-4939700-\$ or US- 4924448-\$ or US-4912685-\$ or US- 4907208-\$ or US-4879697-\$ or US- 4855961-\$ or US-4815045-\$ or US- 4802148-\$ or US-4796238-\$ or US- 4774837-\$ or US-4751645-\$ or US- 4642801-\$ or US-4641290-\$ or US- 4635240-\$ or US-5155706-\$ or US-	US-PGPUB; USPAT; JPO; DERWENT	OR	OFF	2011/12/07 18:32

		4538249-\$ or US-4493064-\$ or US-4456210-\$ or US-4422166-\$).did. or (US-4287578-\$ or US-4262344-\$ or US-4247923-\$ or US-4232380-\$ or US-4216537-\$ or US-4207620-\$ or US-4204281-\$ or US-4200922-\$ or US-4199746-\$ or US-4198702-\$ or US-4197591-\$ or US-4184210-\$ or US-4075599-\$ or US-4068209-\$ or US-4063212-\$ or US-4052693-\$ or US-4047148-\$ or US-4030096-\$ or US-3967234-\$ or US-3964424-\$ or US-3953828-\$ or US-3950723-\$ or US-3949348-\$ or US-3898608-\$ or US-3895340-\$ or US-3895339-\$ or US-3757287-\$).did. or (US-3742436-\$ or US-3716824-\$ or US-3624596-\$ or US-3618006-\$ or US-3585579-\$ or US-3585578-\$ or US-3553638-\$ or US-3484737-\$ or US-3458854-\$ or US-3451038-\$ or US-3381264-\$ or US-3359537-\$ or US-3296579-\$ or US-3144631-\$ or US-3142032-\$ or US-3090030-\$ or US-3005973-\$ or US-2416338-\$ or US-1823329-\$).did. or (JP-61116678-\$ or JP-57046173-\$).did. or (WO-9815846-\$).did.				
S50	22	S49 and sonar and data and column\$2 and display\$4	US-PGPUB; USPAT; USOCR; FPRS; EPO; JPO; DERWENT; IBM_TDB	OR	OFF	2011/12/07 18:32
S51	4	S49 and sonar and data near4 column\$2 and display\$4	US-PGPUB; USPAT; USOCR; FPRS; EPO; JPO; DERWENT; IBM_TDB	OR	OFF	2011/12/07 18:33
S52	1	(form\$3 same first same second same data near5 column\$3 near6 (sonar or acoustic\$4))	US-PGPUB; USPAT; USOCR; FPRS; EPO; JPO; DERWENT; IBM_TDB	OR	OFF	2011/12/07 18:40
S54	5	(form\$3 near5 data near5 column\$3 near6 (sonar or acoustic\$4))	US-PGPUB; USPAT; USOCR; FPRS; EPO; JPO; DERWENT; IBM_TDB	OR	OFF	2011/12/07 18:41
S55	9	((form\$3 or creat\$4) near5 data near5 column\$3 same (sonar or acoustic\$4))	US-PGPUB; USPAT; USOCR; FPRS; EPO; JPO; DERWENT; IBM_TDB	OR	OFF	2011/12/07 18:42

S56	2	column\$4 near4 sonar near4 data same transducer\$2	US-PGPUB; USPAT; USOCR; FPRS; EPO; JPO; DERWENT; IBM_TDB	OR	OFF	2011/12/07 18:44
S57	3	column\$4 near4 sonar same data same transducer\$2	US-PGPUB; USPAT; USOCR; FPRS; EPO; JPO; DERWENT; IBM_TDB	OR	OFF	2011/12/07 18:44
S58	23	column\$4 same sonar same data same transducer\$2	US-PGPUB; USPAT; USOCR; FPRS; EPO; JPO; DERWENT; IBM_TDB	OR	OFF	2011/12/07 18:45
S59	3	sonar near4 data same separat\$4 near4 (column\$2 or table\$2 or file\$2)	US-PGPUB; USPAT; USOCR; FPRS; EPO; JPO; DERWENT; IBM_TDB	OR	OFF	2011/12/07 18:46
S60	333	data near4 column\$3 and sonar	US-PGPUB; USPAT; USOCR; FPRS; EPO; JPO; DERWENT; IBM_TDB	OR	OFF	2011/12/07 18:47
S61	301	data near4 column\$3 and sonar and (sort\$3 or separat\$4)	US-PGPUB; USPAT; USOCR; FPRS; EPO; JPO; DERWENT; IBM_TDB	OR	OFF	2011/12/07 18:47
S62	50	data near4 column\$3 and sonar same (sort\$3 or separat\$4)	US-PGPUB; USPAT; USOCR; FPRS; EPO; JPO; DERWENT; IBM_TDB	OR	OFF	2011/12/07 18:47

12/ 12/ 2011 5:34:53 PM  
H:\ 12-400\ 12460139b.w sp



**IN THE UNITED STATES PATENT AND TRADEMARK OFFICE**

Appl. No.: 12/460,139  
Applicant(s): Hebert et al.  
Filed: 07/14/2009  
Art Unit: 3662  
Examiner: James R. Hulka  
Title: DOWNSCAN IMAGING SONAR

Confirmation No.: 9769

Docket No.: 038495/369324  
Customer No.: 00826

Commissioner for Patents  
P.O. Box 1450  
Alexandria, VA 22313-1450

**AMENDMENT**

Sir:

This is responsive to the Office Action dated September 22, 2011. Please amend the above-identified application as follows:

**Amendments to the Specification** are set forth on page 2 of this paper.

**Amendments to the Claims** are reflected in the listing of claims beginning on page 4 of this paper.

**Remarks** begin on page 16 of this paper.

Amendments to the Specification

At page 11, please amend paragraph 0056 as follows:

[0056] The sonar signal processor 32 may be any means such as a device or circuitry operating in accordance with software or otherwise embodied in hardware or a combination of hardware and software (e.g., a processor operating under software control or the processor embodied as an application specific integrated circuit (ASIC) or field programmable gate array (FPGA) specifically configured to perform the operations described herein, or a combination thereof) thereby configuring the device or circuitry to perform the corresponding functions of the sonar signal processor 32 as described herein. In this regard, the sonar signal processor 32 may be configured to analyze electrical signals communicated thereto by the transceiver 34 to provide sonar data indicative of the size, location, shape, etc. of objects detected by the sonar system 30. In some cases, the sonar signal processor 32 may include a processor, a processing element, a coprocessor, a controller or various other processing means or devices including integrated circuits such as, for example, an ASIC, FPGA or hardware accelerator, that is configured to execute various programmed operations or instructions stored in a memory device. The sonar signal processor may further or alternatively embody multiple compatible additional hardware or hardware and software items to implement signal processing or enhancement features to improve the display characteristics or data or images, collect or process additional data, such as time, temperature, GPS information, waypoint designations, or others, or may filter extraneous data to better analyze the collected data. It may further implement notices and alarms, such as those determined or adjusted by a user, to reflect depth, presence of fish, proximity of other watercraft, etc. Still further, the processor, in combination with suitable memory, may store incoming transducer data or screen images for future playback or transfer, or alter images with additional processing to implement zoom or lateral movement, or to correlate data, such as fish or bottom features to a GPS position or temperature. In an exemplary embodiment, the sonar signal processor 32 may execute commercially available software for controlling the transceiver 34 and/or transducer array 36 and for processing data received therefrom. Further capabilities of the sonar signal processor 32 and other aspects related to the sonar module are described in U.S.

Appl. No.: 12/460,139  
Amdt. dated: 11/30/2011  
Reply to Office Action dated 09/22/2011

Patent Application Serial No. \_\_\_\_\_12/460,093, entitled “Linear and Circular Downscan Imaging Sonar” filed on even date herewith, the disclosure of which is incorporated herein by reference in its entirety.

Amendments to the Claims:

1-56. (Canceled)

57. (Currently Amended) A transducer-array assembly comprising:  
a housing mountable to a watercraft capable of traversing a surface of a body of water;  
and

a linear transducer element positioned within the housing, the linear transducer element having a substantially rectangular shape configured to produce a fan-shaped sonar beam having a relatively narrow beamwidth in a direction parallel to a longitudinal length of the linear transducer element ~~that is significantly less than~~ and a relatively wide beamwidth ~~of the sonar beam~~ in a direction perpendicular to the longitudinal length of the transducer element, the linear transducer element being positioned with the longitudinal length thereof extending in a fore-to-aft direction of the housing;

wherein the linear transducer element is positioned within the housing to project sonar pulses in a direction substantially perpendicular to a plane corresponding to the surface of the body of water.

58. (Currently Amended) The transducer-array assembly of claim 57, wherein the linear transducer element is configured to operate at a selected one of at least two selectable operating frequencies.

59. (Currently Amended) The transducer-array assembly of claim 57, wherein the selectable operating frequencies include about 455 kHz and 800 kHz.

60. (Currently Amended) The transducer-array assembly of claim 57, wherein the beamwidth of the linear transducer element is about 0.8 degrees by about 32 degrees or about 1.4 degrees by about 56 degrees.

61. (Currently Amended) The transducer-~~array~~ assembly of claim 57, wherein the transducer-~~array~~ assembly is configured to communicate with a single transceiver.

62. (Currently Amended) The transducer-~~array~~ assembly of claim 57, wherein a length of a rectangular face of the linear transducer element is about 120 mm and a width of the rectangular face of the linear transducer element is about 3 mm.

63. (Currently Amended) The transducer array of claim 57, wherein the housing is mountable to ~~a vessel to generate sonar pulses defining a~~ the watercraft such that the fan-shaped beam extending extends from one side of the ~~vessel~~ watercraft to an opposite side of the ~~vessel~~ watercraft.

64. (Currently Amended) The transducer-~~array~~ assembly of claim 57, wherein the housing has a streamlined shape.

65. (Currently Amended) The transducer-~~array~~ assembly of claim 57, wherein the beamwidth in the direction parallel to a longitudinal length of the linear transducer element is less than about five percent as large as the beamwidth of the sonar beam in the direction perpendicular to the longitudinal length of the linear transducer element.

66. (Currently Amended) The transducer-~~array~~ assembly of claim 57, wherein the linear transducer element is configured to provide data displayable as sonar data images in which images corresponding to data received via the linear transducer element provide data regarding bottom features over less than fifty percent of a display screen when displayed.

67. (Currently Amended) The transducer-~~array~~ assembly of claim 57, wherein the linear transducer element is configured to provide data displayable as sonar data images in which images corresponding to data received via the linear transducer element provide data regarding bottom features over less than twenty percent of a display screen when displayed.

68. (Currently Amended) The transducer-~~array~~ assembly of claim 57, wherein the linear transducer element is configured to provide data displayable as sonar data images in which images corresponding to data received via the linear transducer element provide data indicative of bottom depth.

69. (Currently Amended) The transducer-~~array~~ assembly of claim 57, wherein the linear transducer element is configured to provide data displayable as sonar data images in which images corresponding to data received via the linear transducer element provide data indicative of water column features.

70. (Currently Amended) The transducer-~~array~~ assembly of Claim 57, wherein the linear transducer element is configured to provide data displayable as sonar data images indicative of bottom data.

71. (Currently Amended) The transducer-~~array~~ assembly of Claim 57, wherein the linear transducer element is configured to provide data displayable as sonar data images indicative of two or more of depth data water column data and bottom data.

72. (Currently Amended) The transducer-~~array~~ assembly of Claim 57, further comprising a circular transducer element positioned to project conical sonar pulses in a direction substantially perpendicular to the plane corresponding to the surface.

73. (Currently Amended) The transducer-~~array~~ assembly of Claim 72, wherein the linear and circular transducer elements are in the same housing.

74. (Currently Amended) The transducer-~~array~~ assembly of Claim 72, wherein the linear transducer and circular transducer elements are positioned to project fan-shaped and conical sonar beams that at least partially overlap.

75. (Currently Amended) The transducer-~~array~~ assembly of claim 72, wherein the sonar signal returns from the circular transducer element and linear transducer element provide generally simultaneous data.

76. (Currently Amended) A sonar system comprising:  
a linear transducer element positioned within a housing that is mountable to a watercraft that traverses a surface of a body of water, the linear transducer element having a substantially rectangular shape configured to produce a fan-shaped sonar beam having a relatively narrow beamwidth in a direction parallel to longitudinal length of the linear transducer element ~~that is significantly less than~~ and a relatively wide beamwidth ~~of the sonar beam~~ in a direction perpendicular to the longitudinal length of the transducer element, the linear transducer element being positioned with the longitudinal length thereof extending in a fore-to-aft direction of the housing

wherein the linear transducer element is positioned to project sonar pulses in a direction substantially perpendicular to a plane corresponding to the surface of ~~[[a]]~~ the body of water;

a sonar module configured to enable operable communication with the transducer-~~array~~ element, the sonar module including:

a sonar signal processor to process sonar return signals ~~received via the linear transducer element~~, and

at least one transceiver configured to provide communication between the linear transducer element and the sonar signal processor.

77. (Original) The sonar system of claim 76, wherein the sonar module further comprises an Ethernet hub in communication with the signal processor.

78. (Original) The sonar system of claim 76, wherein the sonar module is provided within a separate housing.

Appl. No.: 12/460,139  
Amdt. dated: 11/30/2011  
Reply to Office Action dated 09/22/2011

79. (Original) The sonar system of claim 76, further comprising at least one visual display presenting an image representing the processed sonar return signals.

80. (Original) The sonar system of claim 79, wherein the display and the sonar module are in the same housing.

81. (Original) The sonar system of claim 79, wherein at least one display of the plurality of displays is enabled to simultaneously provide different images representing different information from the processed sonar return signals.

82. (Original) The sonar system of claim 76, wherein the sonar module further comprises configuration settings defining a predefined set of display images that may be presented.

83. (Original) The sonar system of claim 76, wherein the linear transducer element is configured to operate at a selected one of at least two selectable operating frequencies.

84. (Original) The sonar system of claim 76, wherein the selectable operating frequencies include about 455 kHz and 800 kHz.

85. (Canceled)

86. (Currently Amended) The sonar system of claim ~~85~~ 76, wherein the housing is mountable to ~~a vessel to generate sonar pulses defining a~~ the watercraft such that the fan-shaped beam extending extends from one side of the ~~vessel~~ watercraft to an opposite side of the ~~vessel~~ watercraft.

87. (Canceled)



88. (Currently Amended) The sonar system of claim 76, wherein the sonar signal processor is configured to display images of sonar data in which images corresponding to data received via the linear transducer element provide data regarding bottom features over less than fifty percent of a display screen when displayed.

89. (Original) The sonar system of claim 76, wherein the sonar signal processor is configured to display images of sonar data corresponding to data received via the linear transducer element representing bottom data.

90. (Original) The sonar system of claim 76, wherein the sonar signal processor is configured to display images of sonar data corresponding to data received via the linear transducer element representing water column data.

91. (Original) The sonar system of claim 76, wherein the sonar signal processor is configured to display images of sonar data corresponding to data received via the linear transducer element representing depth data.

92. (Original) The sonar system of claim 76, wherein the sonar signal processor is configured to display images of sonar data corresponding to data received via the linear transducer element representing two or more of depth data, water column data and bottom data.

93. (Original) The sonar system of claim 76, wherein the sonar signal processor is configured to display images of sonar data corresponding to data received via the linear transducer element representing data vertically below the linear transducer element.

94. (Original) The sonar system of claim 76, further comprising a circular transducer element producing a conical downscan beam.

95. (Original) The sonar system of claim 76, further comprising a circular transducer element producing a conical downscan beam from within the housing.

96. (Currently Amended) The sonar system of claim 94, wherein the sonar pulses from the linear transducer element and the sonar pulses from the circular transducer element insonify areas of the bottom that at least partially overlap.

97. (Original) The sonar system of claim 94, wherein the sonar signal returns from the circular transducer element and linear downscan element provide generally simultaneous data.

98. (Original) The sonar system of claim 76, further comprising sources of data from at least one of the group of radar, GPS, digital mapping, time and temperature.

99. (Original) The sonar system of claim 98, wherein a display format for display of the data is in a user selectable format.

100. (New) The sonar assembly of claim 57, wherein the linear transducer element is configured to emit sonar pulses as well to receive echo returns and convert sound energy of the echo returns into electrical signals.

101. (New) The sonar system of claim 76, wherein the linear transducer element is configured to emit sonar pulses as well to receive echo returns and convert sound energy of the echo returns into electrical signals.

102. (New) The sonar assembly of claim 57, wherein the housing is mounted to the watercraft.

103. (New) The sonar assembly of claim 57, wherein the linear transducer element is configured to produce a generally planar fan-shaped beam.

104. (New) The sonar system of claim 76, further comprising a display in communication with the sonar module.

105. (New) The sonar system of claim 104, wherein the sonar module and display communicate with each other via a network.

106. (New) The sonar system of claim 104, further comprising at least one additional display in communication with the sonar module.

107. (New) The sonar system of claim 104, further comprising a user interface in communication with the sonar module and configured to receive an input from a user.

108. (New) The sonar system of claim 107, wherein the display, the sonar signal processor, and the user interface are all contained in a single housing.

109. (New) The sonar system of claim 107, wherein the user interface is part of the display.

110. (New) The sonar system of claim 104, wherein the linear transducer element, the transceiver, and the display respectively comprise at least two separate modules.

111. (New) The sonar system of claim 76, wherein the housing containing the linear transducer element is mounted to the watercraft.

112. (New) The sonar system of claim 76, wherein the housing containing the linear transducer element is mounted on an intermediate structure that in turn is mounted to the watercraft.

113. (New) The sonar system of claim 104, wherein the sonar signal processor is further configured to implement signal processing or enhancement to improve display characteristics.

114. (New) The sonar system of claim 104, wherein the sonar signal processor is further configured to process GPS information.

115. (New) The sonar system of claim 104, wherein the sonar signal processor is further configured to process waypoint designations.

116. (New) The sonar system of claim 104, wherein the sonar signal processor is further configured to process time data.

117. (New) The sonar system of claim 104, wherein the sonar signal processor is further configured to process temperature data.

118. (New) The sonar system of claim 104, wherein the sonar signal processor is further configured to implement a notice or alarm regarding depth.

119. (New) The sonar system of claim 104, wherein the sonar signal processor is further configured to implement a notice or alarm regarding presence of fish.

120. (New) The sonar system of claim 104, wherein the sonar signal processor is further configured to implement a notice or alarm regarding proximity of other watercraft.

121. (New) The sonar system of claim 104, wherein the processor, in combination with a memory, stores incoming transducer data or screen images for future playback or transfer.

122. (New) The sonar system of claim 104, wherein the sonar signal processor is further configured to perform additional processing to implement zoom.

123. (New) The sonar system of claim 104, wherein the sonar signal processor is further configured to perform additional processing to correlate sonar data to a GPS position.

124. (New) The sonar system of claim 76, wherein the housing containing the linear transducer element has a streamlined profile.

125. (New) The sonar system of claim 76, wherein the housing containing the linear transducer element is mounted on an accessory on the watercraft enabling the fan-shaped beam to assume various orientations with respect to the watercraft.

126. (New) The sonar system of claim 76, further comprising a linear side scan transducer element positioned and configured to produce a fan-shaped beam aimed downwardly and outwardly to one side of the watercraft, wherein dimensions and operating frequencies of the linear transducer element and the linear side scan transducer element are selected to minimize or eliminate any gap between the respective fan-shaped beams.

127. (New) The sonar system of claim 76, further comprising a display in communication with the sonar module, and wherein the system is configured to indicate a position of the watercraft on the display.

128. (New) The sonar system of claim 76, further comprising a display in communication with the sonar module, and wherein the system is configured to indicate water depth on the display.

129. (New) The sonar system of claim 76, further comprising a second transducer positioned and configured to produce a conical sonar beam directed downwardly from the watercraft, wherein the system further includes a display in communication with the sonar module, and wherein the system is configured to indicate on the display an intensity of a return echo received from the conical sonar beam.

130. (New) The sonar system of claim 129, wherein the linear transducer element and the second transducer are both contained in the housing.

131. (New) The sonar system of claim 129, wherein the linear transducer element and the second transducer operate at different respective frequencies.

132. (New) The sonar system of claim 76, further comprising a linear side scan transducer element positioned and configured to produce a fan-shaped beam aimed downwardly

Appl. No.: 12/460,139  
Amdt. dated: 11/30/2011  
Reply to Office Action dated 09/22/2011

and outwardly to one side of the watercraft, wherein the linear transducer element and the linear side scan transducer element are both contained in the housing.

133. (New) The sonar system of claim 132, further comprising a second linear side scan transducer element positioned and configured to produce a fan-shaped beam aimed downwardly and outwardly to an opposite side of the watercraft, wherein the linear transducer element and the linear side scan transducer elements are all contained in the housing.

134. (New) A sonar imaging apparatus comprising:

a housing mountable to a watercraft that traverses a surface of a body of water, the watercraft defining a center plane that extends from fore to aft and that is perpendicular to the surface of the body of water; and

a linear transducer element positioned within the housing, the linear transducer element being configured to produce a sonar beam having a longitudinal beamwidth in a direction parallel to a longitudinal length of the linear transducer element that is significantly less than a transverse beamwidth of the sonar beam in a direction perpendicular to the longitudinal length of the transducer element;

wherein the housing is configured for mounting to the watercraft such that the longitudinal length of the linear transducer element is parallel to said center plane, and

wherein the transverse beamwidth of the sonar beam is sufficiently wide in relation to a direction in which the linear transducer element is aimed such that the transverse beamwidth spans from a port side of said center plane to a starboard side of said center plane.

135. (New) The sonar imaging apparatus of claim 134, further comprising:

a second linear transducer element positioned within the housing, the second linear transducer element being configured to produce a second sonar beam having a longitudinal beamwidth in a direction parallel to a longitudinal length of the second linear transducer element that is significantly less than a transverse beamwidth of the second sonar beam in a direction perpendicular to the longitudinal length of the second linear transducer element.

Appl. No.: 12/460,139  
Amdt. dated: 11/30/2011  
Reply to Office Action dated 09/22/2011

136. (New.) The sonar imaging apparatus of claim 135, wherein the housing is configured for mounting to the watercraft such that the longitudinal length of the second linear transducer element is parallel to said center plane, and wherein the second linear transducer element is arranged such that the second sonar beam extends primarily in a direction different from the sonar beam of the first linear transducer element.

137. (New) The sonar imaging apparatus of claim 136, wherein the transverse beam width of the second sonar beam spans generally to a port side or a starboard side of said center plane.

## REMARKS

Claims 57-84, 86, and 88-137 are pending after entry of the above amendments. Non-elected Claims 1-56 are canceled without prejudice. Claims 85 and 87 are also canceled. New Claims 100-137 have been added.

In the Office Action, Claims 59, 60, 62, and 72 were rejected under 35 U.S.C. 112, second paragraph, as being indefinite because they include the term "about" in connection with various numerical values.

Additionally, Claims 57, 61, 72, 75, 76, 78, 79, 94, and 97 were rejected under 35 U.S.C. 103(a) as being unpatentable over U.S. Patent No. 5,561,641 to Nishimori in view of U.S. Patent Application Publication 2006/0002232 to Shah. Claims 58, 65-71, 74, 80, 81, 83, 88-93, 96, 98, and 99 were rejected as unpatentable over Nishimori and Shah, and further in view of U.S. Patent Application Publication 2007/0025183 to Zimmerman. Claims 64, 73, 77, 85, 87, and 95 were rejected as unpatentable over Nishimori and Shah, and further in view of U.S. Patent No. 7,542,376 to Thompson. Claim 60 was rejected as unpatentable over Nishimori and Shah, and further in view of U.S. Patent No. 5,438,552 to Audi. Claim 62 was rejected as unpatentable over Nishimori and Shah, and further in view of U.S. Patent No. 5,850,372 to Blue and U.S. Patent No. 4,774,837 to Bird. Claims 59 and 84 were rejected as unpatentable over Nishimori and Shah, and further in view of Zimmerman, U.S. Patent No. 4,538,249 to Richard, and U.S. Patent No. 5,184,330 to Adams. Claim 82 was rejected as unpatentable over Nishimori and Shah, and further in view of U.S. Patent No. 5,142,502 to Wilcox. Claims 63 and 86 were rejected as unpatentable over Nishimori and Shah, and further in view of Thompson and Zimmerman.

### Summary of Interview

Applicant thanks the Examiner for his courtesy and helpfulness in the personal interview conducted on November 16, 2011, with Applicant's representatives Michael D. McCoy and Donald M. Hill, Jr. In the interview, the representatives explained the state of the prior art with



Appl. No.: 12/460,139  
Amdt. dated: 11/30/2011  
Reply to Office Action dated 09/22/2011

respect to downscan (i.e., looking directly beneath a watercraft with one or more sonar beams), with reference to a number of exemplary prior art references that were discussed. It was explained that it was conventional in the prior art to aim a conical beam straight down from the watercraft, for purposes of depth sounding as well as acquiring images of water-borne objects such as fish. It was further explained that linear or rectangular transducers were conventionally used for side scan purposes, using the fan-shaped beams produced by such linear transducers to insonify regions to the port and starboard sides of a watercraft. As presently understood by Applicant, however, no prior art reference cited by Applicant or the Examiner has a linear transducer used for downscan as described and claimed in Applicant's application.

The Nishimori reference was discussed, and Applicant's representatives pointed out that Nishimori insonifies a wide conical area with a sonar transmitter and then uses beam-steering techniques with an array of receiving elements for purposes entirely different from those of the present application. Minor clarifying amendments to Claim 57 were also discussed.

#### Summary of Claim Amendments and Additions

Claim 57 has been amended to clarify that it is a transducer "assembly" being claimed. The beam produced by the linear transducer element is now referred to as "fan-shaped" commensurate with the descriptions in the specification. The claim as amended recites that the linear transducer element is positioned with the longitudinal length thereof extending in a fore-to-aft direction of the housing. Claim 57 has also been amended to add "of the body of water" in reference to the "surface" as suggested by the Examiner. The application as filed fully supports these amendments (see, for example, paragraph 0060 and Figures 7A and 7B), such that no new matter has been added. The claims dependent on Claim 57 have been amended in formal respects to be consistent with amended Claim 57.

Independent Claim 76 has been amended in substantially the same fashion as Claim 57. No new matter has been added by these amendments, as noted above. The claims dependent on Claim 76 have been amended in formal respects to be consistent with amended Claim 76.

Appl. No.: 12/460,139  
Amdt. dated: 11/30/2011  
Reply to Office Action dated 09/22/2011

New Claims 100-137 have been added. Support in the application as filed for these new claims is shown in the table below:

New Claim / Feature(s)	Specification Paragraph and/or Figure No(s).
100 and 101. "wherein the linear transducer element is configured to emit sonar pulses as well to receive echo returns and convert sound energy of the echo returns into electrical signals."	¶¶ 0002, 0010, 0056; FIGS. 5, 14
102. "wherein the housing is mounted to the watercraft."	¶¶ 0053, 0057-0060; FIGS. 7A, 7B
103. "wherein the linear transducer element is configured to produce a generally planar fan-shaped beam."	FIG. 7B
104. "further comprising a display in communication with the sonar module."	¶¶ 0051, 0074; FIGS. 5, 14
105. "wherein the sonar module and display communicate with each other via a network."	¶¶ 0051, 0074; FIGS. 5, 14
106. "further comprising at least one additional display in communication with the sonar module."	¶¶ 0051, 0074; FIGS. 5, 14
107. "further comprising a user interface in communication with the sonar module and configured to receive an input from a user."	¶¶ 0052, 0073; FIGS. 5, 14
108. "wherein the display, the sonar signal processor, and the user interface are all contained in a single housing."	¶ 0074
109. "wherein the user interface is part of the display."	¶ 0052
110. "wherein the linear transducer element, the transceiver, and the display respectively comprise three separate modules."	FIG. 5

Appl. No.: 12/460,139  
 Amdt. dated: 11/30/2011  
 Reply to Office Action dated 09/22/2011

111. "wherein the housing containing the linear transducer element is mounted to a hull of the watercraft."	¶¶ 0053, 0057
112. "wherein the housing containing the linear transducer element is mounted on an intermediate structure that in turn is mounted to a hull of the watercraft."	¶ 0057
113. "wherein the sonar signal processor is further configured to implement signal processing or enhancement to improve display characteristics."	¶ 0055
114. "wherein the sonar signal processor is further configured to process GPS information."	¶ 0055
115. "wherein the sonar signal processor is further configured to process waypoint designations."	¶ 0055
116. "wherein the sonar signal processor is further configured to process time data."	¶ 0055
117. "wherein the sonar signal processor is further configured to process temperature data."	¶ 0055
118. "wherein the sonar signal processor is further configured to implement a notice or alarm regarding depth."	¶ 0055
119. "wherein the sonar signal processor is further configured to implement a notice or alarm regarding presence of fish."	¶ 0055
120. "wherein the sonar signal processor is further configured to implement a notice or alarm regarding proximity of other watercraft."	¶ 0055
121. "wherein the processor, in combination	¶ 0055

with a memory, stores incoming transducer data or screen images for future playback or transfer.”	
122. “wherein the sonar signal processor is further configured to perform additional processing to implement zoom.”	¶ 0055
123. “wherein the sonar signal processor is further configured to perform additional processing to correlate sonar data to a GPS position.”	¶ 0055
124. “wherein the housing containing the linear transducer element has a streamlined profile.”	¶ 0057
125. “wherein the housing containing the linear transducer element is mounted on a rotatable accessory on the watercraft enabling the fan-shaped beam to assume various orientations with respect to the watercraft.	¶ 0059
126. “further comprising a linear side scan transducer element positioned and configured to produce a fan-shaped beam aimed downwardly and outwardly to one side of the watercraft, wherein dimensions and operating frequencies of the linear transducer element and the linear side scan transducer element are selected to minimize a size of a gap between the respective fan-shaped beams.	¶ 0063
127. “further comprising a display in communication with the sonar module, and wherein the system is configured to indicate a position of the watercraft on the display.	¶ 0068
128. “further comprising a display in communication with the sonar module, and wherein the system is configured to indicate water depth on the display.”	¶ 0069

<p>129. "further comprising a second transducer positioned and configured to produce a conical sonar beam directed downwardly from the watercraft, wherein the system further includes a display in communication with the sonar module, and wherein the system is configured to indicate on the display an intensity of a return echo received from the conical sonar beam."</p>	<p>¶ 0068</p>
<p>130. "wherein the linear transducer element and the second transducer are both contained in the housing."</p>	<p>¶ 0076; FIGS. 16A-C</p>
<p>131. "wherein the linear transducer element and the second transducer operate at different respective frequencies."</p>	<p>¶ 0073</p>
<p>132. "further comprising a linear side scan transducer element positioned and configured to produce a fan-shaped beam aimed downwardly and outwardly to one side of the watercraft, wherein the linear transducer element and the linear side scan transducer element are both contained in the housing."</p>	<p>¶ 0061; FIG. 8A</p>
<p>133. "further comprising a second linear side scan transducer element positioned and configured to produce a fan-shaped beam aimed downwardly and outwardly to an opposite side of the watercraft, wherein the linear transducer element and the linear side scan transducer elements are all contained in the housing."</p>	<p>¶ 0061; FIG. 8A</p>
<p>134. "A sonar imaging apparatus comprising:                 a housing mountable to a watercraft that traverses a surface of a body of water, the watercraft defining a center plane that extends from fore to aft and that is perpendicular to the surface of the body of</p>	<p>¶¶ 0057-0063; FIGS. 6 through 9B</p>

<p>water; and</p> <p>a linear transducer element positioned within the housing, the linear transducer element being configured to produce a sonar beam having a longitudinal beamwidth in a direction parallel to a longitudinal length of the linear transducer element that is significantly less than a transverse beamwidth of the sonar beam in a direction perpendicular to the longitudinal length of the transducer element;</p> <p>wherein the housing is configured for mounting to the watercraft such that the longitudinal length of the linear transducer element is parallel to said center plane, and</p> <p>wherein the transverse beamwidth of the sonar beam is sufficiently wide in relation to a direction in which the linear transducer element is aimed such that the transverse beamwidth spans from a port side of said center plane to a starboard side of said center plane.”</p>	
<p>135. “further comprising:  a second linear transducer element positioned within the housing, the second linear transducer element being configured to produce a second sonar beam having a longitudinal beamwidth in a direction parallel to a longitudinal length of the second linear transducer element that is significantly less than a transverse beamwidth of the second sonar beam in a direction perpendicular to the longitudinal length of the second linear transducer element.”</p>	<p>¶¶ 0057-0063; FIGS. 6 through 9B</p>
<p>136. “wherein the housing is configured for mounting to the watercraft such that the longitudinal length of the second linear transducer element is parallel to said center</p>	<p>¶¶ 0057-0064; FIGS. 6 through 10B</p>

<p>plane, and wherein the second linear transducer element is arranged such that the second sonar beam extends primarily in a direction different from the sonar beam of the first linear transducer element.”</p>	
<p>137. “wherein the transverse beam width of the second sonar beam spans generally to a port side or a starboard side of said center plane.”</p>	<p>¶¶ 0057-0064; FIGS. 6 through 10B</p>

Thus, no new matter has been added by the addition of new Claims 100-137.

Response to Rejections under 35 U.S.C. 112, Second Paragraph

The Examiner indicated in the interview that the inclusion of the term “about” in reference to numerical values in the claims is not in fact considered to render the claims indefinite. Accordingly, Applicant has not removed this term from the indicated claims, and it is Applicant’s understanding that the rejections under 35 U.S.C. 112, second paragraph, will be withdrawn on next action.

Response to Rejections under 35 U.S.C. 103(a)

All of the rejections hinge on the asserted combination of Nishimori and Shah as allegedly teaching a transducer array having a linear transducer element of rectangular shape, producing a beam that is significantly narrower in a direction parallel to the length of the element than in a direction perpendicular to the length, and wherein the transducer element is positioned in its housing so as to project sonar pulses in a direction substantially perpendicular to a plane corresponding to the surface of the body of water. As pointed out in the interview, however, and as further explained below, Nishimori fails to teach or even remotely suggest such a linear transducer element as claimed in Claims 57 and 76.

The Office Action specifically pointed to col. 18, lines 1-20 of Nishimori, as allegedly teaching a linear transducer arranged as claimed. Nishimori, however, describes a sonar system strikingly distinct from that claimed in Claims 57 and 76. Nishimori's objective is to determine magnitudes and directions of velocities of moving targets within an insonified volume of water, and to display the targets in various colors denoting such magnitudes and directions. To accomplish this, Nishimori emits a wide-area conical beam into the water (Figure 19; col. 11, lines 56-58; col. 26, lines 16-21). This produces echoes or sonar returns potentially coming from all directions from within that conical volume, back to the transducer array. Nishimori then uses a selected sub-set of a multi-direction array of multiple receiving elements to receive those sonar returns and convert them into electrical signals for subsequent signal processing. The receiving array can be a circular array (see Figure 6 and Example 4 described at col. 15 line 50 to col. 16 line 15), or it can be a linear array (see col. 18, lines 15-26). In either case, however, two such receiving elements  $l_p$  and  $l_q$  are used to form two "receiving beams" P and Q that are steered (either mechanically or electronically) with an angular separation  $\theta$  between them. There is a constant time difference between the receipt of the return at the element  $l_p$  and the receipt at the element  $l_q$ . Based on that time difference, Nishimori is able to measure phase differences between the two signals, determine carrier frequencies contained in the target echoes, and thereby deduce the magnitudes and directions of velocities of the targets.

Thus, Nishimori teaches using a transducer producing a conical beam as illustrated in Figure 19. This is similar to the state of the art as noted above, in which it was conventional to aim a conical beam downward for various purposes. Nishimori merely adds to such conventional systems a receiving array and signal processing techniques to deduce velocity information. Accordingly, Nishimori is of no particular relevance to the claimed invention of Applicant's application, since it fails to disclose or suggest a linear transducer element producing a fan-shaped beam positioned within the housing to project sonar pulses in a direction substantially perpendicular to a plane corresponding to the surface of the body of water.



Appl. No.: 12/460,139  
Amdt. dated: 11/30/2011  
Reply to Office Action dated 09/22/2011

Shah is of even less relevance, as it relates to an acoustic signal transmission system for a downhole (well) installation, and in any case does not disclose or suggest a linear transducer element of any kind.

In light of the remarks above, therefore, Applicant respectfully submits that Claims 57 and 76 are patentable over the cited references.

The claims dependent on Claims 57 and 76 are therefore also patentable at least because they include all of the features of their respective independent claim, and further because the cited references fail to teach or suggest the combination of such features with the additional limitations recited in each of the dependent claims.

New independent Claim 134 includes features similar to those of Claims 57 and 76 and thus is submitted to be patentable for reasons substantially the same as those applicable to Claims 57 and 76. Dependent Claims 135-137 are therefore also patentable at least because they include all of the features of Claim 134, and further because the cited references fail to teach or suggest the combination of such features with the additional limitations recited in each of these dependent claims.

\* \* \*

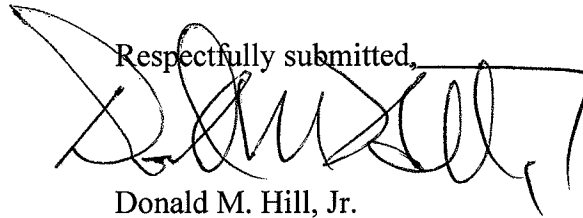
### Conclusion

Based on the above amendments and remarks, it is respectfully submitted that all pending claims are patentable and the application is in condition for allowance.

It is not believed that extensions of time or fees for net addition of claims are required, beyond those that may otherwise be provided for in documents accompanying this paper. However, in the event that additional extensions of time are necessary to allow consideration of this paper, such extensions are hereby petitioned under 37 CFR § 1.136(a), and any fee required

Appl. No.: 12/460,139  
Amdt. dated: 11/30/2011  
Reply to Office Action dated 09/22/2011

therefor (including fees for net addition of claims) is hereby authorized to be charged to Deposit Account No. 16-0605.

Respectfully submitted,  


Donald M. Hill, Jr.  
Registration No. 40,646

**ALSTON & BIRD LLP**  
Bank of America Plaza  
101 South Tryon Street, Suite 4000  
Charlotte, NC 28280-4000  
Tel Charlotte Office (704) 444-1000

**ELECTRONICALLY FILED USING THE EFS-WEB ELECTRONIC FILING SYSTEM OF THE UNITED STATES PATENT & TRADEMARK OFFICE ON NOVEMBER 30, 2011.**

## Electronic Acknowledgement Receipt

<b>EFS ID:</b>	11507604
<b>Application Number:</b>	12460139
<b>International Application Number:</b>	
<b>Confirmation Number:</b>	9769
<b>Title of Invention:</b>	Downscan imaging sonar
<b>First Named Inventor/Applicant Name:</b>	Brian T. Maguire
<b>Customer Number:</b>	826
<b>Filer:</b>	Donald Merton Hill/Grace Rippy
<b>Filer Authorized By:</b>	Donald Merton Hill
<b>Attorney Docket Number:</b>	038495/369324
<b>Receipt Date:</b>	30-NOV-2011
<b>Filing Date:</b>	14-JUL-2009
<b>Time Stamp:</b>	12:14:12
<b>Application Type:</b>	Utility under 35 USC 111(a)

### Payment information:

Submitted with Payment	no
------------------------	----

### File Listing:

Document Number	Document Description	File Name	File Size(Bytes)/ Message Digest	Multi Part /.zip	Pages (if appl.)
1		369324_Amendment11302011.pdf	1171473 21b57a2487763e9cfd223af224506bba3e35899a	yes	26

<b>Multipart Description/PDF files in .zip description</b>			
<b>Document Description</b>		<b>Start</b>	<b>End</b>
Amendment/Req. Reconsideration-After Non-Final Reject		1	1
Specification		2	3
Claims		4	15
Applicant Arguments/Remarks Made in an Amendment		16	26

**Warnings:**

**Information:**

<b>Total Files Size (in bytes):</b>	1171473
-------------------------------------	---------

**This Acknowledgement Receipt evidences receipt on the noted date by the USPTO of the indicated documents, characterized by the applicant, and including page counts, where applicable. It serves as evidence of receipt similar to a Post Card, as described in MPEP 503.**

**New Applications Under 35 U.S.C. 111**

**If a new application is being filed and the application includes the necessary components for a filing date (see 37 CFR 1.53(b)-(d) and MPEP 506), a Filing Receipt (37 CFR 1.54) will be issued in due course and the date shown on this Acknowledgement Receipt will establish the filing date of the application.**

**National Stage of an International Application under 35 U.S.C. 371**

**If a timely submission to enter the national stage of an international application is compliant with the conditions of 35 U.S.C. 371 and other applicable requirements a Form PCT/DO/EO/903 indicating acceptance of the application as a national stage submission under 35 U.S.C. 371 will be issued in addition to the Filing Receipt, in due course.**

**New International Application Filed with the USPTO as a Receiving Office**

**If a new international application is being filed and the international application includes the necessary components for an international filing date (see PCT Article 11 and MPEP 1810), a Notification of the International Application Number and of the International Filing Date (Form PCT/RO/105) will be issued in due course, subject to prescriptions concerning national security, and the date shown on this Acknowledgement Receipt will establish the international filing date of the application.**

Under the Paperwork Reduction Act of 1995, no persons are required to respond to a collection of information unless it displays a valid OMB control number.

<b>PATENT APPLICATION FEE DETERMINATION RECORD</b> Substitute for Form PTO-875	Application or Docket Number <b>12/460,139</b>	Filing Date <b>07/14/2009</b>	<input type="checkbox"/> To be Mailed
---	---	----------------------------------	---------------------------------------

APPLICATION AS FILED – PART I			OTHER THAN SMALL ENTITY				
	(Column 1)	(Column 2)	SMALL ENTITY <input type="checkbox"/>	OR			
FOR	NUMBER FILED	NUMBER EXTRA	RATE (\$)	FEE (\$)	OR	RATE (\$)	FEE (\$)
<input checked="" type="checkbox"/> BASIC FEE <small>(37 CFR 1.16(a), (b), or (c))</small>	N/A	N/A	N/A			N/A	<b>330</b>
<input checked="" type="checkbox"/> SEARCH FEE <small>(37 CFR 1.16(k), (j), or (m))</small>	N/A	N/A	N/A			N/A	<b>540</b>
<input checked="" type="checkbox"/> EXAMINATION FEE <small>(37 CFR 1.16(o), (p), or (q))</small>	N/A	N/A	N/A			N/A	<b>220</b>
TOTAL CLAIMS <small>(37 CFR 1.16(j))</small>	99 minus 20 =	* 79	X \$ =		OR	X \$52 =	<b>4108</b>
INDEPENDENT CLAIMS <small>(37 CFR 1.16(h))</small>	4 minus 3 =	* 1	X \$ =			X \$220 =	<b>220</b>
<input type="checkbox"/> APPLICATION SIZE FEE <small>(37 CFR 1.16(s))</small>	If the specification and drawings exceed 100 sheets of paper, the application size fee due is \$250 (\$125 for small entity) for each additional 50 sheets or fraction thereof. See 35 U.S.C. 41(a)(1)(G) and 37 CFR 1.16(s).						
<input type="checkbox"/> MULTIPLE DEPENDENT CLAIM PRESENT <small>(37 CFR 1.16(j))</small>							
			TOTAL			TOTAL	<b>5418</b>

\* If the difference in column 1 is less than zero, enter "0" in column 2.

APPLICATION AS AMENDED – PART II					OTHER THAN SMALL ENTITY				
	(Column 1)	(Column 2)	(Column 3)						
AMENDMENT	11/30/2011	CLAIMS REMAINING AFTER AMENDMENT	HIGHEST NUMBER PREVIOUSLY PAID FOR	PRESENT EXTRA	RATE (\$)	ADDITIONAL FEE (\$)	OR	RATE (\$)	ADDITIONAL FEE (\$)
	Total (37 CFR 1.16(i))	* 79	Minus ** 99	= 0	X \$ =		OR	X \$60=	0
	Independent (37 CFR 1.16(h))	* 3	Minus ***4	= 0	X \$ =		OR	X \$250=	0
	<input type="checkbox"/> Application Size Fee (37 CFR 1.16(s))								
	<input type="checkbox"/> FIRST PRESENTATION OF MULTIPLE DEPENDENT CLAIM (37 CFR 1.16(j))						OR		
					TOTAL ADD'L FEE		OR	TOTAL ADD'L FEE	<b>0</b>

	(Column 1)	(Column 2)	(Column 3)						
AMENDMENT		CLAIMS REMAINING AFTER AMENDMENT	HIGHEST NUMBER PREVIOUSLY PAID FOR	PRESENT EXTRA	RATE (\$)	ADDITIONAL FEE (\$)	OR	RATE (\$)	ADDITIONAL FEE (\$)
	Total (37 CFR 1.16(i))	*	Minus **	=	X \$ =		OR	X \$ =	
	Independent (37 CFR 1.16(h))	*	Minus ***	=	X \$ =		OR	X \$ =	
	<input type="checkbox"/> Application Size Fee (37 CFR 1.16(s))								
	<input type="checkbox"/> FIRST PRESENTATION OF MULTIPLE DEPENDENT CLAIM (37 CFR 1.16(j))						OR		
					TOTAL ADD'L FEE		OR	TOTAL ADD'L FEE	

\* If the entry in column 1 is less than the entry in column 2, write "0" in column 3.  
 \*\* If the "Highest Number Previously Paid For" IN THIS SPACE is less than 20, enter "20".  
 \*\*\* If the "Highest Number Previously Paid For" IN THIS SPACE is less than 3, enter "3".  
 The "Highest Number Previously Paid For" (Total or Independent) is the highest number found in the appropriate box in column 1.

Legal Instrument Examiner:  
/AJAY R. DAVID/

This collection of information is required by 37 CFR 1.16. The information is required to obtain or retain a benefit by the public which is to file (and by the USPTO to process) an application. Confidentiality is governed by 35 U.S.C. 122 and 37 CFR 1.14. This collection is estimated to take 12 minutes to complete, including gathering, preparing, and submitting the completed application form to the USPTO. Time will vary depending upon the individual case. Any comments on the amount of time you require to complete this form and/or suggestions for reducing this burden, should be sent to the Chief Information Officer, U.S. Patent and Trademark Office, U.S. Department of Commerce, P.O. Box 1450, Alexandria, VA 22313-1450. DO NOT SEND FEES OR COMPLETED FORMS TO THIS ADDRESS. **SEND TO: Commissioner for Patents, P.O. Box 1450, Alexandria, VA 22313-1450.**

If you need assistance in completing the form, call 1-800-PTO-9199 and select option 2.



# UNITED STATES PATENT AND TRADEMARK OFFICE

UNITED STATES DEPARTMENT OF COMMERCE  
United States Patent and Trademark Office  
Address: COMMISSIONER FOR PATENTS  
P.O. Box 1450  
Alexandria, Virginia 22313-1450  
www.uspto.gov

APPLICATION NO.	FILING DATE	FIRST NAMED INVENTOR	ATTORNEY DOCKET NO.	CONFIRMATION NO.
12/460,139	07/14/2009	Brian T. Maguire	038495/369324	9769
826	7590	11/23/2011	EXAMINER	
ALSTON & BIRD LLP BANK OF AMERICA PLAZA 101 SOUTH TRYON STREET, SUITE 4000 CHARLOTTE, NC 28280-4000			HULKA, JAMES R	
			ART UNIT	PAPER NUMBER
			3662	
			MAIL DATE	DELIVERY MODE
			11/23/2011	PAPER

**Please find below and/or attached an Office communication concerning this application or proceeding.**

The time period for reply, if any, is set in the attached communication.

<b>Applicant-Initiated Interview Summary</b>	<b>Application No.</b> 12/460,139	<b>Applicant(s)</b> MAGUIRE, BRIAN T.	
	<b>Examiner</b> JAMES HULKA	<b>Art Unit</b> 3662	

All participants (applicant, applicant's representative, PTO personnel):

- (1) JAMES HULKA. (3) Michael McCoy (Reg. No. 29,098).  
(2) Donald Hill (Reg. No 40,646). (4) \_\_\_\_\_.

Date of Interview: 16 November 2011.

Type:  Telephonic  Video Conference  
 Personal [copy given to:  applicant  applicant's representative]

Exhibit shown or demonstration conducted:  Yes  No.  
If Yes, brief description: \_\_\_\_\_.

Issues Discussed 101 112 102 103 Others  
(For each of the checked box(es) above, please describe below the issue and detailed description of the discussion)

Claim(s) discussed: 57 and 76.

Identification of prior art discussed: Betts, Gilmour, Nishimori.

**Substance of Interview**

(For each issue discussed, provide a detailed description and indicate if agreement was reached. Some topics may include: identification or clarification of a reference or a portion thereof, claim interpretation, proposed amendments, arguments of any applied references etc...)

Applicant's representatives discussed additional prior art from recently filed IDS. Representatives described novel features of claimed invention and cited support in specification for those claims. Representatives also described differences in structure and function of claimed invention in application and distinctions between that and various examiner-cited and applicant-cited references (NPL and patent). Color screen images were shown and provided to the examiner to highlight improvements over prior art. No agreement was made regarding allowability of claims.

**Applicant recordation instructions:** The formal written reply to the last Office action must include the substance of the interview. (See MPEP section 713.04). If a reply to the last Office action has already been filed, applicant is given a non-extendable period of the longer of one month or thirty days from this interview date, or the mailing date of this interview summary form, whichever is later, to file a statement of the substance of the interview

**Examiner recordation instructions:** Examiners must summarize the substance of any interview of record. A complete and proper recordation of the substance of an interview should include the items listed in MPEP 713.04 for complete and proper recordation including the identification of the general thrust of each argument or issue discussed, a general indication of any other pertinent matters discussed regarding patentability and the general results or outcome of the interview, to include an indication as to whether or not agreement was reached on the issues raised.

Attachment

/JAMES HULKA/  
Examiner, Art Unit 3662

## Summary of Record of Interview Requirements

### Manual of Patent Examining Procedure (MPEP), Section 713.04, Substance of Interview Must be Made of Record

A complete written statement as to the substance of any face-to-face, video conference, or telephone interview with regard to an application must be made of record in the application whether or not an agreement with the examiner was reached at the interview.

### Title 37 Code of Federal Regulations (CFR) § 1.133 Interviews

Paragraph (b)

In every instance where reconsideration is requested in view of an interview with an examiner, a complete written statement of the reasons presented at the interview as warranting favorable action must be filed by the applicant. An interview does not remove the necessity for reply to Office action as specified in §§ 1.111, 1.135. (35 U.S.C. 132)

37 CFR §1.2 Business to be transacted in writing.

All business with the Patent or Trademark Office should be transacted in writing. The personal attendance of applicants or their attorneys or agents at the Patent and Trademark Office is unnecessary. The action of the Patent and Trademark Office will be based exclusively on the written record in the Office. No attention will be paid to any alleged oral promise, stipulation, or understanding in relation to which there is disagreement or doubt.

The action of the Patent and Trademark Office cannot be based exclusively on the written record in the Office if that record is itself incomplete through the failure to record the substance of interviews.

It is the responsibility of the applicant or the attorney or agent to make the substance of an interview of record in the application file, unless the examiner indicates he or she will do so. It is the examiner's responsibility to see that such a record is made and to correct material inaccuracies which bear directly on the question of patentability.

Examiners must complete an Interview Summary Form for each interview held where a matter of substance has been discussed during the interview by checking the appropriate boxes and filling in the blanks. Discussions regarding only procedural matters, directed solely to restriction requirements for which interview recordation is otherwise provided for in Section 812.01 of the Manual of Patent Examining Procedure, or pointing out typographical errors or unreadable script in Office actions or the like, are excluded from the interview recordation procedures below. Where the substance of an interview is completely recorded in an Examiners Amendment, no separate Interview Summary Record is required.

The Interview Summary Form shall be given an appropriate Paper No., placed in the right hand portion of the file, and listed on the "Contents" section of the file wrapper. In a personal interview, a duplicate of the Form is given to the applicant (or attorney or agent) at the conclusion of the interview. In the case of a telephone or video-conference interview, the copy is mailed to the applicant's correspondence address either with or prior to the next official communication. If additional correspondence from the examiner is not likely before an allowance or if other circumstances dictate, the Form should be mailed promptly after the interview rather than with the next official communication.

The Form provides for recordation of the following information:

- Application Number (Series Code and Serial Number)
- Name of applicant
- Name of examiner
- Date of interview
- Type of interview (telephonic, video-conference, or personal)
- Name of participant(s) (applicant, attorney or agent, examiner, other PTO personnel, etc.)
- An indication whether or not an exhibit was shown or a demonstration conducted
- An identification of the specific prior art discussed
- An indication whether an agreement was reached and if so, a description of the general nature of the agreement (may be by attachment of a copy of amendments or claims agreed as being allowable). Note: Agreement as to allowability is tentative and does not restrict further action by the examiner to the contrary.
- The signature of the examiner who conducted the interview (if Form is not an attachment to a signed Office action)

It is desirable that the examiner orally remind the applicant of his or her obligation to record the substance of the interview of each case. It should be noted, however, that the Interview Summary Form will not normally be considered a complete and proper recordation of the interview unless it includes, or is supplemented by the applicant or the examiner to include, all of the applicable items required below concerning the substance of the interview.

A complete and proper recordation of the substance of any interview should include at least the following applicable items:

- 1) A brief description of the nature of any exhibit shown or any demonstration conducted,
- 2) an identification of the claims discussed,
- 3) an identification of the specific prior art discussed,
- 4) an identification of the principal proposed amendments of a substantive nature discussed, unless these are already described on the Interview Summary Form completed by the Examiner,
- 5) a brief identification of the general thrust of the principal arguments presented to the examiner,  
(The identification of arguments need not be lengthy or elaborate. A verbatim or highly detailed description of the arguments is not required. The identification of the arguments is sufficient if the general nature or thrust of the principal arguments made to the examiner can be understood in the context of the application file. Of course, the applicant may desire to emphasize and fully describe those arguments which he or she feels were or might be persuasive to the examiner.)
- 6) a general indication of any other pertinent matters discussed, and
- 7) if appropriate, the general results or outcome of the interview unless already described in the Interview Summary Form completed by the examiner.

Examiners are expected to carefully review the applicant's record of the substance of an interview. If the record is not complete and accurate, the examiner will give the applicant an extendable one month time period to correct the record.

### Examiner to Check for Accuracy

If the claims are allowable for other reasons of record, the examiner should send a letter setting forth the examiner's version of the statement attributed to him or her. If the record is complete and accurate, the examiner should place the indication, "Interview Record OK" on the paper recording the substance of the interview along with the date and the examiner's initials.



Substitute for form 1449/PTO (Revised 07/2007)				<b>Complete if Known</b>	
				Application Number	12/460,139
<b>INFORMATION DISCLOSURE STATEMENT BY APPLICANT</b> <i>(Use as many sheets as necessary)</i>				Filing Date	July 14, 2009
				First Named Inventor	Brian T. Maguire
				Art Unit	3662
				Examiner Name	HULKA, James R.
				Attorney Docket Number	038495/369324
Sheet	1	of	16		

U. S. PATENT DOCUMENTS					
Examiner Initials*	Cite No.	Document Number Number - Kind Code (if known)	Publication Date MM-DD-YYYY	Name of Patentee or Applicant of Cited Document	Pages, Columns, Lines, Where Relevant Passages of Relevant Figures Appear
	1.	US-1,823,329	09-15-1931	Marrison	
	2.	US-2,416,338	02-25-1947	Mason	
	3.	US-3,005,973	10-24-1961	Kietz	
	4.	US-3,090,030	05-14-1963	Schuck	
	5.	US-3,142,032	07-21-1964	Jones	
	6.	US-3,144,631	08-11-1964	Lustig, et al.	
	7.	US-3,296,579	01-03-1967	Farr, et al.	
	8.	US-3,359,537	12-19-1967	Geil, et al.	
	9.	US-3,381,264	04-30-1968	Lavergne, et al.	
	10.	US-3,451,038	06-17-1969	Maass	
	11.	US-3,458,854	07-29-1969	Murphree	
	12.	US-3,484,737	12-16-1969	Walsh	
	13.	US-3,553,638	01-05-1971	Sublett	
	14.	US-3,585,578	06-15-1971	Fischer, Jr., et al.	
	15.	US-3,585,579	06-15-1971	Dorr, et al.	
	16.	US-3,618,006	11-02-1971	Wright	
	17.	US-3,624,596	11-30-1971	Dickenson, et al.	
	18.	US-3,716,824	02-13-1973	Door, et al.	
	19.	US-3,742,436	06-26-1973	Jones	
	20.	US-3,757,287	09-04-1973	Bealor, Jr.	
	21.	US-3,895,339	07-15-1975	Jones, et al.	
	22.	US-3,895,340	07-15-1975	Gilmour	
	23.	US-3,898,608	08-05-1975	Jones, et al.	
	24.	US-3,949,348	04-06-1976	Dorr	
	25.	US-3,950,723	04-13-1976	Gilmour	

Examiner Signature		Date Considered	
-----------------------	--	--------------------	--

\*Examiner: Initial if reference considered, whether or not citation is in conformance with MPEP 609. Draw line through citation if not in conformance and not considered. Include copy of this form with next communication to applicant.

Substitute for form 1449/PTO (Revised 07/2007)				<b>Complete if Known</b>	
				Application Number	12/460,139
<b>INFORMATION DISCLOSURE STATEMENT BY APPLICANT</b> <i>(Use as many sheets as necessary)</i>				Filing Date	July 14, 2009
				First Named Inventor	Brian T. Maguire
				Art Unit	3662
				Examiner Name	HULKA, James R.
				Attorney Docket Number	038495/369324
Sheet	2	of	16		

U. S. PATENT DOCUMENTS					
Examiner Initials*	Cite No.	Document Number Number - Kind Code (if known)	Publication Date MM-DD-YYYY	Name of Patentee or Applicant of Cited Document	Pages, Columns, Lines, Where Relevant Passages of Relevant Figures Appear
	26.	US-3,953,828	04-27-1976	Cook	
	27.	US-3,964,424	06-22-1976	Hagemann	
	28.	US-3,967,234	06-29-1976	Jones	
	29.	US-4,030,096	06-14-1977	Stevens, et al.	
	30.	US-4,047,148	09-06-1977	Hagemann	
	31.	US-4,052,693	10-04-1977	Gilmour	
	32.	US-4,063,212	12-13-1977	Sublett	
	33.	US-4,068,209	01-10-1978	Lagier	
	34.	US-4,075,599	02-21-1978	Kosalos, et al.	
	35.	US-4,184,210	01-15-1980	Hageman	
	37.	US-4,197,591	04-08-1980	Hagemann	
	38.	US-4,198,702	04-15-1980	Clifford	
	39.	US-4,199,746	04-22-1980	Jones, et al.	
	40.	US-4,200,922	04-29-1980	Hagemann	
	41.	US-4,204,281	05-20-1980	Hagemann	
	42.	US-4,207,620	06-10-1980	Morgera	
	43.	US-4,216,537	08-05-1980	Delignieres	
	44.	US-4,232,380	11-04-1980	Caron, et al.	
	45.	US-4,247,923	01-27-1987	De Kok	
	46.	US-4,262,344	04-14-1981	Gilmour	
	47.	US-4,287,578	09-01-1981	Heyser	
	48.	US-4,422,166	12-20-1983	Klein	
	49.	US-4,456,210	06-26-1984	McBride	
	50.	US-4,493,064	01-08-1985	Odero, et al.	
	52.	US-4,538,249	08-27-1985	Richard	

Examiner Signature		Date Considered	
--------------------	--	-----------------	--

\*Examiner: Initial if reference considered, whether or not citation is in conformance with MPEP 609. Draw line through citation if not in conformance and not considered. Include copy of this form with next communication to applicant.

Substitute for form 1449/PTO (Revised 07/2007)				<b>Complete if Known</b>	
				Application Number	12/460,139
<b>INFORMATION DISCLOSURE STATEMENT BY APPLICANT</b> <i>(Use as many sheets as necessary)</i>				Filing Date	July 14, 2009
				First Named Inventor	Brian T. Maguire
				Art Unit	3662
				Examiner Name	HULKA, James R.
				Attorney Docket Number	038495/369324
Sheet	3	of	16		

U. S. PATENT DOCUMENTS					
Examiner Initials*	Cite No.	Document Number Number - Kind Code (if known)	Publication Date MM-DD-YYYY	Name of Patentee or Applicant of Cited Document	Pages, Columns, Lines, Where Relevant Passages of Relevant Figures Appear
	53.	US-4,635,240	01-06-1987	Geohegan, Jr., et al.	
	54.	US-4,641,290	02-03-1987	Massa, et al.	
	55.	US-4,642,801	02-10-1987	Perny	
	56.	US-4,751,645	06-14-1988	Abrams, et al.	
	57.	US-4,774,837	10-04-1988	Bird	
	58.	US-4,796,238	01-03-1989	Bourgeois, et al.	
	59.	US-4,802,148	01-31-1989	Gilmour	
	60.	US-4,815,045	03-21-1989	Nakamura	
	61.	US-4,855,961	08-08-1989	Jaffe, et al.	
	62.	US-4,879,697	11-07-1989	Lowrance, et al.	
	63.	US-4,907,208	03-06-1990	Lowrance et al.	
	64.	US-4,912,685	03-27-1990	Gilmour	
	65.	US-4,924,448	05-08-1990	Gaer	
	66.	US-4,939,700	07-03-1990	Breton	
	67.	US-4,958,330	09-18-1990	Higgins	
	68.	US-4,970,700	11-13-1990	Gilmour, et al.	
	69.	US-4,975,887	12-04-1990	Maccabee, et al.	
	70.	US-4,982,924	01-08-1991	Havins	
	71.	US-5,033,029	07-16-1991	Jones	
	72.	US-5,109,364	04-28-1992	Stiner	
	73.	US-5,113,377	05-12-1992	Johnson	
	74.	US-5,142,502	08-25-1992	Wilcox, et al.	
	75.	US-5,155,706	10-13-1992	Haley, et al.	
	76.	US-5,182,732	01-26-1993	Pichowkin	
	77.	US-5,184,330	02-02-1993	Adams, et al.	

Examiner Signature		Date Considered	
--------------------	--	-----------------	--

\*Examiner: Initial if reference considered, whether or not citation is in conformance with MPEP 609. Draw line through citation if not in conformance and not considered. Include copy of this form with next communication to applicant.

Substitute for form 1449/PTO (Revised 07/2007)				<b>Complete if Known</b>	
				Application Number	12/460,139
<b>INFORMATION DISCLOSURE STATEMENT BY APPLICANT</b> <i>(Use as many sheets as necessary)</i>				Filing Date	July 14, 2009
				First Named Inventor	Brian T. Maguire
				Art Unit	3662
				Examiner Name	HULKA, James R.
				Attorney Docket Number	038495/369324
Sheet	4	of	16		

U. S. PATENT DOCUMENTS					
Examiner Initials*	Cite No.	Document Number Number - Kind Code (if known)	Publication Date MM-DD-YYYY	Name of Patentee or Applicant of Cited Document	Pages, Columns, Lines, Where Relevant Passages of Relevant Figures Appear
	78.	US-5,200,931	04-06-1993	Kosalos, et al.	
	79.	US-5,214,744	05-25-1993	Schweizer, et al.	
	80.	US-5,241,314	08-31-1993	Keeler, et al.	
	81.	US-5,245,587	09-14-1993	Hutson	
	82.	US-5,243,567	09-07-1993	Gingerich	
	83.	US-5,257,241	10-26-1993	Henderson, et al.	
	84.	US-5,260,912	11-09-1993	Latham	
	85.	US-5,303,208	04-12-1994	Dorr	
	86.	US-5,376,933	12-27-1994	Tupper, et al.	
	87.	US-5,390,152	02-14-1995	Boucher, et al.	
	88.	US-5,412,618	05-02-1995	Gilmour	
	89.	US-5,438,552	08-01-1995	Audi, et al.	
	90.	US-5,442,358	08-15-1995	Keeler, et al.	
	91.	US-5,455,806	10-03-1995	Hutson	
	92.	US-5,493,619	02-20-1996	Haley, et al.	
	93.	US-5,515,337	05-07-1996	Gilmour, et al.	
	94.	US-5,537,366	07-16-1996	Gilmour	
	95.	US-5,546,356	08-13-1996	Zehner	
	96.	US-5,561,641	10-01-1996	Nishimori, et al.	
	97.	US-5,574,700	11-12-1996	Chapman	
	98.	US-5,596,549	01-21-1997	Sheriff	
	99.	US-5,602,801	02-11-1997	Nussbaum, et al.	
	100.	US-5,612,928	03-18-1997	Haley, et al.	
	101.	US-5,694,372	12-02-1997	Perennes	
	102.	US-5,805,528	09-08-1998	Hamada et al.	

Examiner Signature		Date Considered	
--------------------	--	-----------------	--

\*Examiner: Initial if reference considered, whether or not citation is in conformance with MPEP 609. Draw line through citation if not in conformance and not considered. Include copy of this form with next communication to applicant.

Substitute for form 1449/PTO (Revised 07/2007)  <b>INFORMATION DISCLOSURE          STATEMENT BY APPLICANT</b> <i>(Use as many sheets as necessary)</i>				<b>Complete if Known</b>			
				Application Number		12/460,139	
				Filing Date		July 14, 2009	
				First Named Inventor		Brian T. Maguire	
				Art Unit		3662	
				Examiner Name		HULKA, James R.	
Sheet	5	of	16	Attorney Docket Number		038495/369324	

U. S. PATENT DOCUMENTS					
Examiner Initials*	Cite No.	Document Number Number - Kind Code (if known)	Publication Date MM-DD-YYYY	Name of Patentee or Applicant of Cited Document	Pages, Columns, Lines, Where Relevant Passages of Relevant Figures Appear
	103.	US-5,850,372	12-15-1998	Blue	
	105.	US-5,930,199	07-27-1999	Wilk	
	106.	US-5,991,239	11-23-1999	Fatemi-Booshehri et al.	
	107.	US-6,002,644	12-14-1999	Wilk	
	108.	US-6,084,827	07-04-2000	Johnson, et al.	
	109.	US-6,215,730	04-20-2001	Pinto	
	110.	US-6,335,905	01-01-2002	Kabel	
	111.	US-6,421,299	07-16-2002	Betts, et al.	
	112.	US-6,449,215	09-10-2002	Shell	
	113.	US-6,537,224	03-25-2003	Mauchamp, et al.	
	114.	US-6,606,958	08-19-2003	Bouyoucos	
	115.	US-6,678,403	01-13-2004	Wilk	
	116.	US-6,738,311	05-18-2004	Guigne	
	117.	US-6,842,401	01-11-2005	Chiang, et al.	
	118.	US-6,941,226	09-06-2005	Estep	
	119.	US-6,980,688	12-27-2005	Wilk	
	120.	US-7,236,427	06-26-2007	Schroeder	
	121.	US-7,355,924	04-08-2008	Zimmerman, et al.	
	122.	US-7,405,999	07-29-2008	Skjold-Larsen	
	123.	US-7,542,376	06-02-2009	Thompson, et al.	
	124.	US-7,652,952	01-26-2010	Betts, et al.	
	125.	US-7,710,825	05-04-2010	Betts, et al.	
	126.	US-7,729,203	06-01-2010	Betts, et al.	
	127.	US-7,755,974	07-13-2010	Betts, et al.	
	128.	US-2003/0202426 A1	10-30-2003	Ishihara et al.	

Examiner Signature		Date Considered	
--------------------	--	-----------------	--

\*Examiner: Initial if reference considered, whether or not citation is in conformance with MPEP 609. Draw line through citation if not in conformance and not considered. Include copy of this form with next communication to applicant.

Substitute for form 1449/PTO (Revised 07/2007)  <b>INFORMATION DISCLOSURE          STATEMENT BY APPLICANT</b> <i>(Use as many sheets as necessary)</i>				<b>Complete if Known</b>		
				Application Number	12/460,139	
				Filing Date	July 14, 2009	
				First Named Inventor	Brian T. Maguire	
				Art Unit	3662	
				Examiner Name	HULKA, James R.	
Sheet	6	of	16	Attorney Docket Number	038495/369324	

U. S. PATENT DOCUMENTS					
Examiner Initials*	Cite No.	Document Number Number - Kind Code (if known)	Publication Date MM-DD-YYYY	Name of Patentee or Applicant of Cited Document	Pages, Columns, Lines, Where Relevant Passages of Relevant Figures Appear
	129.	US 2004/0184351 A1	09-23-2004	Nishimori, et al.	
	130.	US 2005/0043619 A1	02-24-2005	Sumanaweera, et al.	
	131.	US 2005/0099887 A1	05-12-2005	Zimmerman, et al.	
	132.	US 2006/0002232 A1	01-05-2006	Shah, et al.	
	133.	US 2007/0025183 A1	02-01-2007	Zimmerman, et al.	
	134.	US 2007/0091723 A1	04-26-2007	Zhu, et al.	
	135.	US-2011/0013484 A1	01-20-2011	Coleman et al.	
	136.	US-2011/0013485 A1	01-20-2011	Maguire	
	137.	US-Des. 329,615	09-22-1992	Stiner	
	138.	US-Des. 329,616	09-22-1992	Stiner	

Examiner Initials*	Cite No.	Foreign Patent Document Country Code - Number Kind Code (if known)	Publication Date MM-DD-YYYY	Name of Patentee or Applicant of Cited Document	Pages, Columns, Lines, Where Relevant Passages or Relevant Figures Appear	English Language Translation Attached
	139.	GB 1,316,138	05-09-1973	Dickinson, et al.		
	140.	JP 57-046173 (A)	03-16-1982	Furuno Electric Co.		Abstract
	141.	JP 61-116678 (A)	06-04-1986	Furuno Electric Co.		Abstract
	142.	JP 4357487 (A)	12-10-1992	Furuno Electric Co.		Abstract
	143.	WO 98/15846	04-16-1998	Rowe-Deines Instruments, Incorporated		

Examiner Signature		Date Considered	
--------------------	--	-----------------	--

\*Examiner: Initial if reference considered, whether or not citation is in conformance with MPEP 609. Draw line through citation if not in conformance and not considered. Include copy of this form with next communication to applicant.

Substitute for form 1449/PTO (Revised 07/2007)				<b>Complete if Known</b>	
				Application Number	12/460,139
<b>INFORMATION DISCLOSURE STATEMENT BY APPLICANT</b> <i>(Use as many sheets as necessary)</i>				Filing Date	July 14, 2009
				First Named Inventor	Brian T. Maguire
				Art Unit	3662
				Examiner Name	HULKA, James R.
				Attorney Docket Number	038495/369324
Sheet	7	of	16		

<b>OTHER DOCUMENTS</b>			
Examiner Initials*	Cite No.	Include name of the author (in CAPITAL LETTERS), title of the article (when appropriate), title of the item (book, magazine, journal, serial, symposium, catalog, etc.), date, page(s), volume-issue number(s), publisher, city and/or country where published.	English Language Translation Attached
	144.	ANDERSON, K.; "Side-Scanning for Sport Fishing"; Salt Water Sportsman; April 1, 2009; 4 pages	
	145.	ANDREW, C., et al.; "Setup and Trouble shooting Procedures for the Klein 5500 Sidescan Sonar"; Australian Government; Department of Defence; Maritime Operations Division; Systems Sciences Laboratory; Published November 2003	
	146.	ARMSTRONG, A.A., et al.; "New Technology for Shallow Water Hydrographic Surveys"; Proceedings of the 25 <sup>th</sup> Joint Meeting of UJNR Sea-bottom Surveys Panel; December, 1996	
	147.	ASPLIN, R.G., et al.; "A new Generation Side Scan Sonar"; OCEANS '88 Proceedings. 'A Partnership of Marine Interests'; Vol. 2; October-November 1988; pp. 329-334	
	148.	CAREY, W.M., "Sonar Array Characterization, Experimental Results"; IEEE Journal of Oceanic Engineering ; Vol. 23; Issue 3; July 1998; pp. 297-306	
	149.	BAKER, N., et al, "Rifting History of the Northern Mariana Trough: SeaMARCH II and Seismic Reflection Surveys," Journals of Geophysical Research, Vol. 101, No. B5, May 10, 1996	
	150.	COWIE, P.A., et al, "Quantitative Fault Studies on the East Pacific Rise: A Comparison of Sonar Imaging Techniques," Journal of Geophysical Research, Vol. 99, B8, August 10, 1994	
	151.	CURCIO, J., et al.; "SCOUT - A Low Cost Autonomous Surface Platform for Research in Cooperative Autonomy"; Department of Mechanical Engineering; Massachusetts Institute of Technology; August 2005	
	152.	FARRELL, E.J.; , "Color Display and Interactive Interpretation of Three-Dimensional Data"; IBM Journal of Research and Development; Vol.27; No.4; July 1983; pp.356-366	
	153.	GLYNN, JR., J.M., et al.; "Survey Operations and Results Using a Klein 5410 Bathymetric Sidescan Sonar"; Retrieved from the Internet <URL: <a href="http://www.thsoa.org/hy07/03_04.pdf">http://www.thsoa.org/hy07/03_04.pdf</a> ; March 2007	
	154.	HANSEN, H.H.; "Circular vs. rectangular transducers"; Department of Electronics and Telecommunications; Norwegian University of Science and Technolgy; March 2010; 28 pages	

Examiner Signature		Date Considered	
--------------------	--	-----------------	--

\*Examiner: Initial if reference considered, whether or not citation is in conformance with MPEP 609. Draw line through citation if not in conformance and not considered. Include copy of this form with next communication to applicant.

Substitute for form 1449/PTO (Revised 07/2007)  <b>INFORMATION DISCLOSURE          STATEMENT BY APPLICANT</b> <i>(Use as many sheets as necessary)</i>				<b>Complete if Known</b>			
				Application Number		12/460,139	
				Filing Date		July 14, 2009	
				First Named Inventor		Brian T. Maguire	
				Art Unit		3662	
				Examiner Name		HULKA, James R.	
Sheet	8	of	16	Attorney Docket Number	038495/369324		

<b>OTHER DOCUMENTS</b>			
Examiner Initials*	Cite No.	Include name of the author (in CAPITAL LETTERS), title of the article (when appropriate), title of the item (book, magazine, journal, serial, symposium, catalog, etc.), date, page(s), volume-issue number(s), publisher, city and/or country where published.	English Language Translation Attached
	155.	HUGHES CLARKE, J. E., et al.; "Knudsen 320 200 kHz keel-mounted sidescan trials; Results from 2000/2001/2002 field operations; [online]; Retrieved on 6/23/2010 from the Internet <URL: <a href="http://www.omg.unb.ca/Ksidescan/K320_SS Trials.html">http://www.omg.unb.ca/Ksidescan/K320_SS Trials.html</a> ; 11 pages	
	156.	HUGHES CLARKE, J.E.; "Seafloor characterization using keel-mounted sidescan: proper compensation for radiometric and geometric distortion"; Canadian Hydrographic Conference; May 2004; 18 pages	
	157.	HUSSONG, D.M., et al., "High-Resolution Acoustic Seafloor Mapping," 20 <sup>th</sup> Annual OTC, Houston, TX, May 2-5, 1988	
	158.	JONSSON, J., et al. "Simulation and Evaluation of Small High-Frequency Side-Scan Sonars using COMSOL"; Excerpt from the Proceedings of the COMSOL Conference; 2009; Milan, Italy	
	159.	KEY, W.H.; "Side Scan Sonar Technology"; Oceans 2000 MTS/IEEE Conference and Exhibition; Volume 2; September 2000; pp. 1029-1033	
	160.	KIELCZYNSKI, P., et al.; "Finite Element Method (FEM) and Impulse Response Method (IRM) analysis of circular and rectangular transducers"; 1995 IEEE Ultrasonics Symposium; 1995; pp. 693-696	
	161.	KOZAK, G.; "Side Scan Sonar Target Comparative Techniques for Port Security and MCM Q-Route Requirements"; L-3 Communications; Klein Associates, Inc.; [Online]; Retrieved from the Internet <URL: <a href="http://www.chesapeakeotech.com/techniques-port-security.pdf">http://www.chesapeakeotech.com/techniques-port-security.pdf</a> ; 11 pages	
	162.	KROTSER, D.J., et al.; "Side-Scan Sonar: Selective Textural Enhancement"; Oceans'76; Washington, DC; September 1976	
	163.	KVITEK, R.G., et al.; "Victoria Land Latitudinal Gradient Project: Benthic Marine Habitat Characterization"; California State University; Monterey Bay; Field Report; February 25, 2004	
	164.	LANGERAAR, W.; "Surveying and Charting of the Seas"; Elsevier Oceanography Series; Volume 37; September, 1983; page 321	
	165.	MANLEY, J.E.; "Development of the Autonomous Surface Craft 'Aces'"; Oceans '97 MTS/IEEE Conference Proceedings; October 1997; pp. 827- 832	
	166.	MANLEY, J.E., et al.; "Evolution of the Autonomous Surface Craft 'AutoCat'"; Oceans 2000 MTS/IEEE Conference and Exhibition; Volume 1; September 2000; pp. 403-408	

Examiner Signature		Date Considered	
--------------------	--	-----------------	--

\*Examiner: Initial if reference considered, whether or not citation is in conformance with MPEP 609. Draw line through citation if not in conformance and not considered. Include copy of this form with next communication to applicant.



Substitute for form 1449/PTO (Revised 07/2007)				<b>Complete if Known</b>	
				Application Number	12/460,139
<b>INFORMATION DISCLOSURE STATEMENT BY APPLICANT</b> <i>(Use as many sheets as necessary)</i>				Filing Date	July 14, 2009
				First Named Inventor	Brian T. Maguire
				Art Unit	3662
				Examiner Name	HULKA, James R.
				Attorney Docket Number	038495/369324
Sheet	9	of	16		

<b>OTHER DOCUMENTS</b>			
Examiner Initials*	Cite No.	Include name of the author (in CAPITAL LETTERS), title of the article (when appropriate), title of the item (book, magazine, journal, serial, symposium, catalog, etc.), date, page(s), volume-issue number(s), publisher, city and/or country where published.	English Language Translation Attached
	167.	MELVIN, G., et al.; Commercial fishing vessels, automatic acoustic logging systems and 3D data visualization"; ICES; Journal of Marine Science; Vol. 59; Issue 1; 2002; pp. 179-189	
	168.	NEWMAN, P.M.; "MOOS-Mission Orientated Operating Suite"; Department of Ocean Engineering; Massachusetts Institute of Technology; 2002	
	169.	OLLIVIER, F., et al.; "Side scan sonar using phased arrays for high resolution imaging and wide swath bathymetry"; IEEE Proceedings on Radar, Sonar and Navigation; Volume 143; Issue 3; June 1996; pp. 163-168	
	170.	PRICKETT, T.; "Underwater Inspection of Coastal Structures"; The REMR Bulletin; Vol. 14; No. 2; August, 1997;	
	171.	PRATSON, L.F., et al.; "Introduction to advances in seafloor mapping using sidescan sonar and multibeam bathymetry data"; Marine Geophysical Research; Springer Netherlands; Volume 18; Issue 6; 1996; pp. 601-605	
	172.	PRYOR, Donald E.; "Theory and Test of Bathymetric Side Scan Sonar"; Office of Charting and Geodetic Services; National Ocean Service; National Oceanic and Atmospheric Administration; Post 1987; pp. 379-384	
	173.	SHONO, K., et al.; "Integrated Hydro-Acoustic Survey Scheme for Mapping of Sea Bottom Ecology"; Ocean Research Institute; Tokyo, Japan; November 2004	
	174.	TREVORROW, M.V., et al.; "Description and Evaluation of a Four-Channel, Coherent 100-kHz Sidescan Sonar"; Defence R&D Canada-Atlantic; December 2004	
	175.	VAGANAY, J., et al.; "Experimental validation of the Moving Long Base-Line Navigation Concept"; 2004 IEEE/OES Autonomous Underwater Vehicles; June 2004	
	176.	VANECK, T.W., et al.; "Automated Bathymetry Using an Autonomous Surface Craft"; Journal of the Institute of Navigation; Volume 43; Issue 4; Winter 1996; pp. 329-334	
	177.	WAITE, A.D.; "Sonar for Practising Engineers"; Third Edition; John Wiley & Sons, Ltd.; West Sussex, England; © 2002; 323 pages	
	178.	Alpine Geophysical Data Programmer Model 485C Brochure and letter dated February 17, 1976; 2 pages	
	179.	Benthos C3D Sonar Imaging System; "High Resolution Side Scan Imagery with Bathymetry"; Benthos, Inc.; © May 2002	

Examiner Signature		Date Considered	
--------------------	--	-----------------	--

\*Examiner: Initial if reference considered, whether or not citation is in conformance with MPEP 609. Draw line through citation if not in conformance and not considered. Include copy of this form with next communication to applicant.

Substitute for form 1449/PTO (Revised 07/2007)				<b>Complete if Known</b>	
<b>INFORMATION DISCLOSURE STATEMENT BY APPLICANT</b> <i>(Use as many sheets as necessary)</i>				Application Number	12/460,139
				Filing Date	July 14, 2009
				First Named Inventor	Brian T. Maguire
				Art Unit	3662
				Examiner Name	HULKA, James R.
				Attorney Docket Number	038495/369324
Sheet	10	of	16		

<b>OTHER DOCUMENTS</b>					
Examiner Initials*	Cite No.	Include name of the author (in CAPITAL LETTERS), title of the article (when appropriate), title of the item (book, magazine, journal, serial, symposium, catalog, etc.), date, page(s), volume-issue number(s), publisher, city and/or country where published.	English Language Translation Attached		
	180.	Coastal Engineering Technical Note; "Side-Scan Sonar for Inspecting Coastal Structures"; U.S. Army Engineer Waterways Experiment Station; Revised 11/1983			
	181.	ConCAT Containerised Catamaran; Inshore hydrographic survey vessel that fits in a container; In Cooperation with Uniteam International; Kongsberg Simrad AS; April 2004			
	182.	Datasonics SIS-1000 Seafloor Imaging System; Combined Chirp Side Scan Sonar/Chirp Sub-Bottom Profiling for high resolution seafloor imaging; One System, All the Answers; Benthos, Inc.; © 2000			
	183.	Detailed Sonar Transducer Product Information; Transducer Products; Side Scans; Models T36, T63, T62, and T403; 12/30/2003; Retrieved from internet: <a href="http://www.neptune-sonar.com/products.as_btype=Side-Scan+Transducers&amp;category=">URL:http://www.neptune-sonar.com/products.as_btype=Side-Scan+Transducers&amp;category=</a> ; 4 pages			
	184.	Kongsberg Brochure EA 400 Survey; "A complete, integrated survey system"; Kongsberg Maritime AS; October 2003			
	185.	Kongsberg Brochure EA 400/600 "Sidescan Echo sounder with combined sidescan and depth soundings"; Kongsberg Maritime AS; May 2004			
	186.	EDO CORPORATION GLOBAL TECHNOLOGY REACH, Model 6400 Fan Beam Transducer; <a href="http://web.archive.org/web/20040608054923/www.edoceramic.com/NavDucers.htm">http://web.archive.org/web/20040608054923/www.edoceramic.com/NavDucers.htm</a> ; June 3, 2004			
	187.	EM1110-2-1003; Department of the Army; U.S. Army Corps of Engineers; Engineering and Design; Hydrographic Surveying; April 1, 2004			
	188.	File Wrapper of Provisional Application Serial No. 60/552,769; Filed: 3/12/04; Applicant: Terrence Schoreder			
	189.	Final Report; Early Implementation of Nearshore Ecosystem Database Project Tasks 2 and 3; [online]; Retrieved on 2/26/2010 from the Internet <URL: <a href="http://seafloor.csUMB.edu/taskforce/html%20%20web/finalreport.htm">http://seafloor.csUMB.edu/taskforce/html%20%20web/finalreport.htm</a> ; 90 pages			
	190.	FishFinder L265 Instruction Manual; Raymarine; 79 pages			
	191.	FishFinder L365 Instruction Manual; Raymarine; 83 pages			

Examiner Signature		Date Considered	
--------------------	--	-----------------	--

\*Examiner: Initial if reference considered, whether or not citation is in conformance with MPEP 609. Draw line through citation if not in conformance and not considered. Include copy of this form with next communication to applicant.

Substitute for form 1449/PTO (Revised 07/2007)  <b>INFORMATION DISCLOSURE          STATEMENT BY APPLICANT</b> <i>(Use as many sheets as necessary)</i>				<b>Complete if Known</b>			
				Application Number		12/460,139	
				Filing Date		July 14, 2009	
				First Named Inventor		Brian T. Maguire	
				Art Unit		3662	
				Examiner Name		HULKA, James R.	
Sheet	11	of	16	Attorney Docket Number		038495/369324	

<b>OTHER DOCUMENTS</b>			
Examiner Initials*	Cite No.	Include name of the author (in CAPITAL LETTERS), title of the article (when appropriate), title of the item (book, magazine, journal, serial, symposium, catalog, etc.), date, page(s), volume-issue number(s), publisher, city and/or country where published.	English Language Translation Attached
	192.	FishFinder L470 Instruction Manual; Raymarine; 102 pages	
	193.	FishFinder L750 Instruction Manual; Raymarine; 93 pages	
	194.	GeoAcoustics; A Kongsberg Company; GeoSwath Plus Brochure; "Wide swath bathymetry and georeferenced side scan"; [Online]; Retrieved from the internet <URL: <a href="http://www.km.kongsberg.com/ks/web/nokbg0397.nsf/AllWeb/F4B7FD3461368388C1257599002D34BC/\$file/GeoSwath-Plus-brochure.pdf?OpenElement">http://www.km.kongsberg.com/ks/web/nokbg0397.nsf/AllWeb/F4B7FD3461368388C1257599002D34BC/\$file/GeoSwath-Plus-brochure.pdf?OpenElement</a> ;	
	195.	GeoPulse; "GeoAcoustics Pinger Sub-Bottom Profiler; Retrieved from the Internet <URL: <a href="http://www.km.kongsberg.com/ks/web/nokbg0397.nsf/AllWeb/D1084BB7DD0FD21DC12574C0003E01EA/\$file/GeoPulse_Profiler.pdf?OpenElement">http://www.km.kongsberg.com/ks/web/nokbg0397.nsf/AllWeb/D1084BB7DD0FD21DC12574C0003E01EA/\$file/GeoPulse_Profiler.pdf?OpenElement</a> ; GeoAcoustics Limited, UK; A Kongsberg Company	
	196.	GlobalMap Sport; Installation and Operation Instructions; Lowrance Electronics, Inc.; ©1996; 61 pages	
	197.	GPS Speed Correction; Sidescan Sonar; [online]; Retrieved from the Internet URL: < <a href="http://www.hydrakula.uni-kiel.de/downloads/Sidescan%20Sonar.doc">www.hydrakula.uni-kiel.de/downloads/Sidescan%20Sonar.doc</a> ; 10 pages	
	198.	HUMMINBIRD 1197c Operations Manual; 11/6/2007; 188 pages	
	199.	HUMMINBIRD 200DX DUAL BEAM Operations Manual; 43 pages	
	200.	HUMMINBIRD 500 Series; 550, 560, 570 and 570 DI Operations Manual; © 2010; 84 pages	
	201.	Humminbird: America's favorite Fishfinder – the leading innovator of Side Imaging technology; [Online]; [Retrieved on 03-16-2011]; Retrieved from the Internet <URL: <a href="http://www.humminbird.com/support/ProductManuals.aspx">http://www.humminbird.com/support/ProductManuals.aspx</a> >; 20 pages	
	202.	Humminbird: America's favorite Fishfinder – the leading innovator of Side Imaging technology; [Online]; [Retrieved on 03-16-2011]; Retrieved from the Internet <URL: <a href="http://www.humminbird.com/support/ProductManuals.aspx">http://www.humminbird.com/support/ProductManuals.aspx</a> >; 5 pages	
	203.	HUMMINBIRD Dimension 3 Sonar 600 Operations Manual; 24 pages	
	204.	THE HUMMINBIRD GPS NAVIGATIONAL SYSTEM. NOTHING ELSE EVEN CLOSE.; HUMMINBIRD Marine Information Systems ®; 1992; 10 pages	
	205.	HUMMINBIRD GPS NS 10 Operations Manual; 75 pages	

Examiner Signature		Date Considered	
--------------------	--	-----------------	--

\*Examiner: Initial if reference considered, whether or not citation is in conformance with MPEP 609. Draw line through citation if not in conformance and not considered. Include copy of this form with next communication to applicant.

Substitute for form 1449/PTO (Revised 07/2007)				<b>Complete if Known</b>	
				Application Number	12/460,139
<b>INFORMATION DISCLOSURE STATEMENT BY APPLICANT</b> <i>(Use as many sheets as necessary)</i>				Filing Date	July 14, 2009
				First Named Inventor	Brian T. Maguire
				Art Unit	3662
				Examiner Name	HULKA, James R.
Sheet	12	of	16	Attorney Docket Number	038495/369324

<b>OTHER DOCUMENTS</b>			
Examiner Initials*	Cite No.	Include name of the author (in CAPITAL LETTERS), title of the article (when appropriate), title of the item (book, magazine, journal, serial, symposium, catalog, etc.), date, page(s), volume-issue number(s), publisher, city and/or country where published.	English Language Translation Attached
	206.	HUMMINBIRD High Speed Transducer; 4 pages	
	207.	HUMMINBIRD LCR 400 ID Operations Manual; 28 pages	
	208.	HUMMINBIRD Marine Information Systems; Dimension 3 Sonar™; 1992; 16 pages	
	209.	HUMMINBIRD "Matrix 35 Fishing System," Prior to August 2, 2003	
	210.	HUMMINBIRD Matrix 35 Fishing System; 2 pages	
	211.	HUMMINBIRD MATRIX 55 AND 65 Operations Manual; ©2003; 40 pages	
	212.	HUMMINBIRD Matrix 67 GPS Trackplotter Operations Manual; ©2003; 88 pages	
	213.	HUMMINBIRD "Matrix 97 GPS Trackplotter Operations Manual" 2003	
	214.	HUMMINBIRD Matrix 97 Operations Manual; ©2003; 87 pages	
	215.	HUMMINBIRD Matrix™ 87c Operations Manual; ©2004; 45 pages	
	216.	HUMMINBIRD The New Wave of Wide; 1997; HUMMINBIRD WIDE®; fish wide open!®; 24 pages	
	217.	HUMMINBIRD NS25 Operations Manual; 71 pages	
	218.	HUMMINBIRD Piranha 1 & 2 Operation Guide; 5 pages	
	219.	HUMMINBIRD Platinum ID 120 Operations Manual; 36 pages	
	220.	HUMMINBIRD Platinum ID 600 Operations Manual; 18 pages	
	221.	HUMMINBIRD "The Product Line>Matrix Products>Matrix 35" <a href="http://web.archive.org/web/20030404000447/www.humminbird.com/hb_Products.asp?ID">http://web.archive.org/web/20030404000447/www.humminbird.com/hb_Products.asp?ID</a> , April 4, 2003	
	222.	Humminbird® Trolling Motor Mounted Transducer with Mount Assembly Brochure; © 2008 Humminbird®, Eufaula, AL; 2 pages	
	223.	HUMMINBIRD Wide 3D Paramount Operations Manual; 44 pages	
	224.	HUMMINBIRD Wide 3D View Operations Manual; 38 pages	

Examiner Signature		Date Considered	
--------------------	--	-----------------	--

\*Examiner: Initial if reference considered, whether or not citation is in conformance with MPEP 609. Draw line through citation if not in conformance and not considered. Include copy of this form with next communication to applicant.

Substitute for form 1449/PTO (Revised 07/2007)				<b>Complete if Known</b>	
				Application Number	12/460,139
<b>INFORMATION DISCLOSURE STATEMENT BY APPLICANT</b> <i>(Use as many sheets as necessary)</i>				Filing Date	July 14, 2009
				First Named Inventor	Brian T. Maguire
				Art Unit	3662
				Examiner Name	HULKA, James R.
Sheet	13	of	16	Attorney Docket Number	038495/369324

<b>OTHER DOCUMENTS</b>			
Examiner Initials*	Cite No.	Include name of the author (in CAPITAL LETTERS), title of the article (when appropriate), title of the item (book, magazine, journal, serial, symposium, catalog, etc.), date, page(s) , volume-issue number(s), publisher, city and/or country where published.	English Language Translation Attached
	225.	HUMMINBIRD Wide 3D Vision Operations Manual; 38 pages	
	226.	HUMMINBIRD Wide 3D Vista Operations Manual; 38 pages	
	227.	HUMMINBIRD Wide Eye Operations Manual; 32 pages	
	228.	HUMMINBIRD Wide Paramount Operations Manual; fish wide open!; 32 pages	
	229.	HUMMINBIRD "Wideside"; Schematic; December 15, 1994; 5 pages	
	230.	Hydro Products; A Tetra Tech Company; 4000 Series Giffit Precision Depth Recorder Product Brochure; date stamped 1977	
	231.	The Hydrographic Society – Corporate Member News – KONGSBERG SIMRAD; July 3, 2008; 7 pages	
	232.	Imagenex Model 855 Brochure: Online; Documents retrieved from internet web archives as follows: <a href="http://web.archive.org/web/20021023212210/http://www.imagenex.com/Products/855_858/855_858.html">URL:http://web.archive.org/web/20021023212210/http://www.imagenex.com/Products/855_858/855_858.html</a> ; 1 page; Archived on October 23, 2002 <a href="http://web.archive.org/web/20021024124035/http://www.imagenex.com/Products/855_858/855/855.html">URL:http://web.archive.org/web/20021024124035/http://www.imagenex.com/Products/855_858/855/855.html</a> ; 1 page; Archived on October 24, 2002 <a href="http://web.archive.org/web/20021024125254/http://www.imagenex.com/Products/855_858/858/858.html">URL:http://web.archive.org/web/20021024125254/http://www.imagenex.com/Products/855_858/858/858.html</a> ; 1 page; Archived on October 24, 2002 <a href="http://web.archive.org/web/20030424071306/http://www.imagenex.com/855_Page_1.jpg">URL:http://web.archive.org/web/20030424071306/http://www.imagenex.com/855_Page_1.jpg</a> ; 1 page; Archived on April 24, 2003 <a href="http://web.archive.org/web/20030424091547/http://www.imagenex.com/855_Page_2.jpg">URL:http://web.archive.org/web/20030424091547/http://www.imagenex.com/855_Page_2.jpg</a> ; 1 page; Archived on April 24, 2003 <a href="http://web.archive.org/web/20030424094158/http://www.imagenex.com/855_Page_3.jpg">URL:http://web.archive.org/web/20030424094158/http://www.imagenex.com/855_Page_3.jpg</a> ; 1 page; Archived on April 24, 2003 <a href="http://web.archive.org/web/20030424101301/http://www.imagenex.com/855_Page_4.jpg">URL:http://web.archive.org/web/20030424101301/http://www.imagenex.com/855_Page_4.jpg</a> ; 1 page; Archived on April 24, 2003 <a href="http://web.archive.org/web/20030424101939/http://www.imagenex.com/855_Page_5.jpg">URL:http://web.archive.org/web/20030424101939/http://www.imagenex.com/855_Page_5.jpg</a> ; 1 page; Archived on April 24, 2003 <a href="http://web.archive.org/web/20030424135458/http://www.imagenex.com/855_Page_6.jpg">URL:http://web.archive.org/web/20030424135458/http://www.imagenex.com/855_Page_6.jpg</a> ; 1 page; Archived on April 24, 2003 <a href="http://web.archive.org/web/20030424141232/http://www.imagenex.com/855_Page_7.jpg">URL:http://web.archive.org/web/20030424141232/http://www.imagenex.com/855_Page_7.jpg</a> ; 1 page; Archived on April 24, 2003 <a href="http://web.archive.org/web/20030424143158/http://www.imagenex.com/855_Page_8.jpg">URL:http://web.archive.org/web/20030424143158/http://www.imagenex.com/855_Page_8.jpg</a> ; 1 page; Archived on April 24, 2003	

Examiner Signature	Date Considered
--------------------	-----------------

\*Examiner: Initial if reference considered, whether or not citation is in conformance with MPEP 609. Draw line through citation if not in conformance and not considered. Include copy of this form with next communication to applicant.

Substitute for form 1449/PTO (Revised 07/2007)				<b>Complete if Known</b>	
				Application Number	12/460,139
<b>INFORMATION DISCLOSURE STATEMENT BY APPLICANT</b> <i>(Use as many sheets as necessary)</i>				Filing Date	July 14, 2009
				First Named Inventor	Brian T. Maguire
				Art Unit	3662
				Examiner Name	HULKA, James R.
Sheet	14	of	16	Attorney Docket Number	038495/369324

<b>OTHER DOCUMENTS</b>			
Examiner Initials*	Cite No.	Include name of the author (in CAPITAL LETTERS), title of the article (when appropriate), title of the item (book, magazine, journal, serial, symposium, catalog, etc.), date, page(s), volume-issue number(s), publisher, city and/or country where published.	English Language Translation Attached
	233.	Imagenex Model 872 "Yellowfin" Sidescan Sonar; Imagenex Technology Corp.; © 2004 - 2009	
	234.	The Imagenex SportScan; Digital Sidescan Sonar; "Redefining Image Clarity"; Imagenex Technology Corp.; © 2002	
	235.	Imagenex SportScan Digital SideScan Sonar Brochure: Online; Documents retrieved from internet web archives as follows: <a href="http://web.archive.org/web/20030212030409/http://www.imagenex.com/Products/products.html">URL:http://web.archive.org/web/20030212030409/http://www.imagenex.com/Products/products.html</a> ; 1 page; Archived on February 12, 2003 <a href="http://web.archive.org/web/20030214044915/http://www.imagenex.com/Products/SportScan/sportscan.html">URL:http://web.archive.org/web/20030214044915/http://www.imagenex.com/Products/SportScan/sportscan.html</a> ; 1 page; Archived on February 14, 2003 <a href="http://web.archive.org/web/20030222152337/http://www.imagenex.com/Products/SportScan/SportScan_Specs/sportscan_specs.html">URL:http://web.archive.org/web/20030222152337/http://www.imagenex.com/Products/SportScan/SportScan_Specs/sportscan_specs.html</a> ; 3 pages; Archived on February 22, 2003 <a href="http://web.archive.org/web/20030222161450/http://www.imagenex.com/Products/SportScan/FAQ_s/faq_s.html">URL:http://web.archive.org/web/20030222161450/http://www.imagenex.com/Products/SportScan/FAQ_s/faq_s.html</a> ; 4 pages; Archived on February 22, 2003 <a href="http://web.archive.org/web/20030419024526/http://www.imagenex.com/Products/SportScan/distributors.html">URL:http://web.archive.org/web/20030419024526/http://www.imagenex.com/Products/SportScan/distributors.html</a> ; 2 page; Archived on April 19, 2003	
	236.	IMAGENEX (Various) Technical Specifications and User's Manual; Prior to August 2003	
	237.	Innomar – Products; "System Variants: SES Side Scan Option"; Retrieved from internet <a href="http://www.innomar.com/produ_2000sidescan.htm">URL:http://www.innomar.com/produ_2000sidescan.htm</a> ; 12/30/2003; 2 pages	
	238.	International Search Report and Written Opinion for Application No. PCT/US2010/039441 dated October 11, 2010	
	239.	International Search Report and Written Opinion for Application No. PCT/US2010/039443 dated October 6, 2010	
	240.	"ITC Application Equations for Underwater Sound Transducers"; Published by International Transducer Corporation, 1995, Rev. 8/00; 3 pages	
	241.	Kelvin Hughes Transit Sonar; "... a new dimension in shallow water survey to assist in ..."; Hydrography; Dredging; Salvage; Underwater Construction and Similar Works; March 1966; 8 pages	
	242.	KLEIN DIGITAL SONAR SYSTEMS, "... The Next Generation From the World Leader in Side Scan Sonar and Sub-bottom Profiling Systems," 1988	
Examiner Signature		Date Considered	

\*Examiner: Initial if reference considered, whether or not citation is in conformance with MPEP 609. Draw line through citation if not in conformance and not considered. Include copy of this form with next communication to applicant.

Substitute for form 1449/PTO (Revised 07/2007)				<b>Complete if Known</b>	
				Application Number	12/460,139
<b>INFORMATION DISCLOSURE STATEMENT BY APPLICANT</b> <i>(Use as many sheets as necessary)</i>				Filing Date	July 14, 2009
				First Named Inventor	Brian T. Maguire
				Art Unit	3662
				Examiner Name	HULKA, James R.
				Attorney Docket Number	038495/369324
Sheet	15	of	16		

<b>OTHER DOCUMENTS</b>			
Examiner Initials*	Cite No.	Include name of the author (in CAPITAL LETTERS), title of the article (when appropriate), title of the item (book, magazine, journal, serial, symposium, catalog, etc.), date, page(s) , volume-issue number(s), publisher, city and/or country where published.	English Language Translation Attached
	243.	Lowrance HS-3DWN Transducer Assembly and Housing (Eagle IID); August 1994	
	244.	Lowrance LCX-18C & LCX-19C Fish-finding Sonar & Mapping GPS; Operation Instructions; ©2002; 200 pages	
	245.	Lowrance Transducers Product Information; 1 page	
	246.	Navico Design Report of Raytheon Electronics Side Looker Transducer; 3/12/2010; 18 pages	
	247.	NOAA: Nautical Charting general information from public records; [Online]; Retrieved on 9/10/2010 from the Internet < URL: <a href="http://www.nauticalcharts.noaa.gov/csd/learn_hydroequip.html">http://www.nauticalcharts.noaa.gov/csd/learn_hydroequip.html</a> ; 2 pages; <a href="http://www.nauticalcharts.noaa.gov/csd/learn_hydroequip.html">http://www.nauticalcharts.noaa.gov/csd/learn_hydroequip.html</a> ; 1 page; <a href="http://www.nauticalcharts.noaa.gov/csd/PDBS.html">http://www.nauticalcharts.noaa.gov/csd/PDBS.html</a> ; 2 pages; <a href="http://www.nauticalcharts.noaa.gov/hsd/pub.html">http://www.nauticalcharts.noaa.gov/hsd/pub.html</a> ; 1 page; <a href="http://www.nauticalcharts.noaa.gov/hsd/fpm/fpm.htm">http://www.nauticalcharts.noaa.gov/hsd/fpm/fpm.htm</a> ; 1 page; <a href="http://www.ozcoasts.gov.au/geom_geol/toolkit/Tech_CA_sss.jsp">http://www.ozcoasts.gov.au/geom_geol/toolkit/Tech_CA_sss.jsp</a> ; 12 pages	
	248.	ONR Grant N66604-05-1-2983; Final Report; "Cooperative Autonomous Mobile Robots"; Retrieved from the Internet <URL: <a href="http://dodreports.com/pdf/ada463215.pdf">http://dodreports.com/pdf/ada463215.pdf</a> ; Post 2006	
	249.	Odom Echoscans™: For Sea Floor or Riverbed Surveys; Odom Hydrographic Systems; 04/26/2002	
	250.	Odom Hydrographic Systems ECHOSCAN Manual; Revision 1.11; 04/26/2002	
	251.	"Product Survey Side-Scan Sonar"; Hydro International Magazine; Volume 36; April 2004; pp. 36-39	
	252.	R/V QUICKSILVER; Hydrographic Survey Launch Bareboat or Crewed; F/V Norwind, Inc.	
	253.	R/V TANGAROA; Fact Sheet; Explore lost worlds of the deep; Norfanz Voyage; May 10 to June 8, 2003	
	254.	SeaBat 8101 Product Specification; 240kHz Multibeam Echo Sounder; ©1999 RESON Inc.; Version 4.0	

Examiner Signature		Date Considered	
--------------------	--	-----------------	--

\*Examiner: Initial if reference considered, whether or not citation is in conformance with MPEP 609. Draw line through citation if not in conformance and not considered. Include copy of this form with next communication to applicant.

Substitute for form 1449/PTO (Revised 07/2007)			<b>Complete if Known</b>		
<b>INFORMATION DISCLOSURE STATEMENT BY APPLICANT</b> <i>(Use as many sheets as necessary)</i>			Application Number	12/460,139	
			Filing Date	July 14, 2009	
			First Named Inventor	Brian T. Maguire	
			Art Unit	3662	
			Examiner Name	HULKA, James R.	
Sheet	16	of	16	Attorney Docket Number	038495/369324

<b>OTHER DOCUMENTS</b>			
Examiner Initials*	Cite No.	Include name of the author (in CAPITAL LETTERS), title of the article (when appropriate), title of the item (book, magazine, journal, serial, symposium, catalog, etc.), date, page(s), volume-issue number(s), publisher, city and/or country where published.	English Language Translation Attached
	255.	SIMRAD EA 500; Hydrographic Echo Sounder; Product Specifications; Revision: September 1993	
	256.	SonarBeam Underwater Surveying System Using T-150P tow-fish hull mounted; [Online]; [Retrieved on 2/12/2010 from the Internet <URL: <a href="http://dsmeu.en.ec21.com/Remotely_Operated_Sonar_Boat_System--618904_2479905.html">http://dsmeu.en.ec21.com/Remotely_Operated_Sonar_Boat_System--618904_2479905.html</a> ]; 4 pages; <a href="http://www.remtechnology.en.ec21.com/Side_Scan_Sonar_Remotely_Operated--2902034.html">http://www.remtechnology.en.ec21.com/Side_Scan_Sonar_Remotely_Operated--2902034.html</a> ; 4 pages; [Retrieved on 2/16/2010 from the Internet <URL: <a href="http://dsmeu.en.ec21.com/Remotely_Operated_Sonar_Boat_System--618904_2479905.html">http://dsmeu.en.ec21.com/Remotely_Operated_Sonar_Boat_System--618904_2479905.html</a> ]; 4 pages; <a href="http://www.remtechnology.en.ec21.com/Side_Scan_Sonar_Remotely_Operated--2902230.html">http://www.remtechnology.en.ec21.com/Side_Scan_Sonar_Remotely_Operated--2902230.html</a> ; 7 pages	
	257.	Starfish 450H; Sidescan System; Tritech International Limited; UK	
	258.	T297-00-01-01 Transducer housing outline drawing; Neptune Sonar Ltd.; ©2002	
	259.	TECHSONIC INDUSTRIES, INC.; "Mask, Acoustic"; Schematic, May 24, 1996	
	260.	TECHSONIC INDUSTRIES, INC.; "Element, 455 kHz"; Schematic, June 13, 1996	
	261.	"Transducers Quad Beam," Prior to August 2, 2003	
	262.	U-Tech Company Newsletter	
	263.	USACE, "Chapter 11, Acoustic Multibeam Survey Systems for Deep-Draft Navigation Projects," April 1, 2004	
	264.	Ultra III 3D Installation and Operation Instructions; EAGLE™; ©1994	
	265.	Westinghouse Publication; "Side-Scan Sonar Swiftly Surveys Subsurface Shellfish"; May 1970; 4 pages	
	266.	Sonar Theory and Applications; Excerpt from Imagenex Model 855 Color Imaging Sonar User's Manual; Imagenex Technology Corp.; Canada; 8 pages	

Examiner Signature		Date Considered	
-----------------------	--	--------------------	--

\*Examiner: Initial if reference considered, whether or not citation is in conformance with MPEP 609. Draw line through citation if not in conformance and not considered. Include copy of this form with next communication to applicant.



# PATENT SPECIFICATION

(11) 1316138

1316138

## DRAWINGS ATTACHED

- (21) Application No. 28638/70 (22) Filed 12 June 1970  
(23) Complete Specification filed 13 Aug. 1971  
(44) Complete Specification published 9 May 1973  
(51) International Classification G01S 9/68  
(52) Index at acceptance  
H4D G1A G4A5 G5A3A G5D  
(72) Inventors DEREK LEONARD DICKINSON,  
JOHN GILBERT FRANKHAM and  
RODNEY JAMES SAUNDERS



## (54) IMPROVEMENTS RELATING TO SONAR APPARATUS

(71) We, BRITISH AIRCRAFT CORPORATION LIMITED, a British company of 100 Pall Mall, London, S.W.1, do hereby declare the invention, for which we pray that a patent may be granted to us, and the method by which it is to be performed, to be particularly described in and by the following statement:—

This invention is concerned with sonar systems for determining the depth of the seabed and the presence of objects on the seabed. Apparatus embodying the invention may be used, for example, to survey the seabed contours in order to increase the safety of navigation where the under-keel clearance is small and may be carried on ships or other waterborne craft.

Sonar system are known in which a pulse of acoustic energy is transmitted into the sea with a radiation pattern substantially consisting of a single lobe which is very narrow in plan view. For example, a train of such pulses can be broadcast from the side of a ship which is moving forward, the speed of forward movement and the interval between the pulses being such that a succession of parallel, closely spaced seabed contours are derived.

Normally, the transmitted pulse "runs along" the seabed in a straight line. The pulse does not actually run along the seabed, instead it is broadcast over a fairly wide angle in elevation and reaches the seabed along this line at progressively later instants, but the concept of the pulse running along the seabed is a convenient one for the purposes of explanation.

It will be clear that in determining these seabed contours, the angular movement of the ship has to be taken into account. Thus, if the ship yaws, then it is necessary to swing the radiation pattern with respect to the ship so that the pulse is actually transmitted in the direction which it would have had in the absence of yaw. If the ship pitches, a different kind of error results and this is more difficult to correct.

We have found that if the ship pitches, the pulse appears to run along the seabed in a straight line parallel to the line obtained in the absence of pitching but that this can be compensated by introducing a correction, in a manner to be described. According to the present invention, the sonar transmitter has in one plane a radiation pattern made up of a number of angularly spaced lobes and the apparatus further includes, for correcting data derived by sonar apparatus for error due to ship pitching movement, control means operative in response to any specific value of a control input signal to swing different lobes to different extents in a direction perpendicular to the said plane, the extent of swing of each lobe depending on the value of the control signal; when the apparatus is arranged on a ship so that the said plane is perpendicular to the longitudinal axis of the ship and the lobes are downwardly directed, and when the control signal varies with the pitching angle of the ship, the angle of swing for any lobe is in the yaw direction and varies in magnitude with the pitching angle so as to reduce the effect of ship pitching movement on the direction of transmission of the lobe. It will be appreciated that in a practical case compensation must also be introduced for the movement of the ship in yaw, the effect of which is to cause the whole sonic radiation pattern to swing in yaw. Consequently, in addition to the selective displacements of the different lobes to correct for pitching, there must be an overall correction to each lobe to counter the yawing movement of the ship.

For reasons to be explained, if the seabed field of interest includes the area immediately under the ship, a correction in yaw alone could not provide the necessary pitch compensation. To overcome this difficulty, in the preferred form of apparatus we arrange for the transducers responsible for the different lobes to form a curved array in the vertical plane. Because of this curvature, the overall correction to each lobe to counter the yawing move-

ment of the ship will be calculated by a procedure which is the reverse of that employed for pitch correction, i.e. the lobe making the greatest angle with the seabed (vertically downwards) has no yaw component and so requires no correction; that making the least angle has only a yaw component and so requires full correction.

The angular deviation of the radiation pattern is preferably achieved by introducing phase differences between radiation from different transducers along a horizontal transmitter strip, that is to say by progressively delaying the arrival of an energising waveform at the transducers along the strip.

In order that the invention may be better understood, an explanation of the correction and an example of apparatus embodying the invention will now be described with reference to the accompanying drawings, in which:—

Figure 1a is a diagram illustrating the problem;

Figure 1b shows diagrammatically the curved transducer mounting;

Figures 2a and 2b are diagrams showing in elevation and plan the radiation lobes of the sonar transmitter;

Figure 3 shows a transmitter panel carrying a number of transducer arrays; and

Figure 4 is a block diagram of a circuit for one transmitter transducer array.

In Figure 1a, a ship 10 carrying the transducers has a horizontal fore-and-aft axis 11. The ship is a distance  $d$  above the seabed and in the absence of ship movement, the pulse appears to run out over the seabed along the line 12. If the ship pitches, so that the ship's "vertical" makes an angle  $\theta$  with the true vertical, then the line of intersection of the transmitted pulse with the seabed is a line 13 parallel with the line 12 and displaced therefrom by a distance depending upon the angle of pitch.

It will be appreciated that in the course of a pitching movement, the angle of pitch of the ship varies continuously. Consequently, the line 13 will move away from and then back towards the line 12 and will then cross over to the other side of the line 12, and so on. For one particular pitching angle  $\theta$ , the distance between the lines 12 and 13 is  $d \tan \theta$ , as can be seen from a consideration of the distance between point P, immediately below the ship, and point P<sub>1</sub>. If we now consider a point P<sub>2</sub> which is the intersection with the seabed, of a pulse transmitted at an angle  $\gamma$  in the vertical plane, when the ship has a pitch angle of  $\theta$  this intersection will be moved to point P<sub>3</sub>. It will be seen that approximately the same error could result if the ship had no pitching motion but had an angle of yaw of which the tangent is approximately

$$\frac{d \tan \theta}{R},$$

i.e. approximately

$$\frac{d \tan \theta}{d \tan \gamma},$$

65

Thus, if the beam transmitted at this angle in the elevational plane is given such a yaw angle (in addition to any yaw angle required to compensate for yaw movement of the ship), the point of intersection of the beam transmitted with an angle  $\gamma$  in the vertical plane, with the seabed, will again be P<sub>2</sub>. For each point along the line 12 (except immediately under the ship) there is an angle of yaw which, if applied to the beam, will correct for the pitching angle  $\theta$  of the ship. Because this angle of yaw includes in the divisor the term  $d \tan \gamma$  representing the distance from a point below the ship to the point at which the wave reaches the seabed, transmitted waves in different ones of the vertically spaced arrays, having different values of R, will be transmitted with different yaw angles to compensate for a given pitching angle of the ship.

This analysis is only approximate and a correction in yaw alone could not provide the pitch compensation necessary for the seabed area directly under the ship. In the preferred form of the invention, we overcome this difficulty by using a curved array. Figure 1b shows diagrammatically in a vertical plane the curved mounting 14 for the transducers and the lobes 16 leaving the transducers.

Figure 2a is a diagram representing an elevation through the survey ship and shows the different lobes 16, side by side in the vertical plane but slightly overlapping one another. Figure 2b shows in plan view the lobes 16 overlapping one another along the line 12 on the seabed. In this example, six lobes 16 are shown but there can be more than this, for example ten lobes. The subsidiary lobes 18 can be disregarded for the present purposes. As before, in the absence of differential swinging of the lobes to counteract pitching movement of the ship, the multi-lobe pulse seems to run out from a point under the ship along the common axis of the overlapping lobes.

Figure 3 shows a transmitter panel for obtaining the pattern of angularly spaced lobes in the vertical plane. The projector arrays 20, consisting of a number of horizontally spaced transducers, are vertically spaced from one another on a curved panel 22, the different angles of the arrays (in the vertical plane) due to this curvature being responsible for the

different directions of the lobes in the vertical plane, giving substantially even illumination of the full 90° lateral elevation sector and also allowing full pitch and yaw correction. If there are ten lobes, there are ten protector arrays, and in one example, each array had 32 transducer elements, the adjacent elements being separated horizontally by a half-wavelength to provide a steering sector of 30°, with the phase shift available in the drive circuits of this example.

Figure 4 is a block diagram of the electronic circuits for one transmitter transducer array. The transducer elements of an array are all driven at the carrier frequency but with variable relative phases, adjustment of the signal phases in a progressive manner across the array allowing the formation of a steerable transmitted beam of narrow width and minimal side lobes.

The phase difference between transmitted signals is derived in the following manner. The carrier frequency  $f$  is produced in this example by counting down from a crystal oscillator of frequency  $64f$ , using a separate 6-bit binary counter for each transducer. Clearly, the timing or phase of the counter outputs can be varied in discrete steps of  $1/64f$  seconds by alternation of the timing of gates which feed the clock signals to the digital counters.

In this example, the transmission pulse has a minimum repetition frequency of 3 per second and is initiated by a pulse of length 316 microseconds occurring every 333 milliseconds. This pulse opens gate 30 (Figure 4) and the gate is held open for the period of 316 microseconds. The pulse is generated by a conventional counter circuit driven by the master clock.

The pulses from the master clock passing through the gate 30 are applied to a counter 32 which has a number of parallel connections between its counting stages and corresponding stages in a timing logic circuit 34. The timing logic circuit is controlled by a beam angle demand signal. As an example of this control, if the beam angle is such as to require delays between adjacent transducer transmissions equivalent to the period of five of the pulse periods of the master clock, the circuit 34 will provide one pulse in very five from the master clock at its output. These selected pulses are counted in a 5-bit counter 36 which has 32 output connections, that is to say one for each of its possible counting combinations. These 32 output connections go to beam phase logic circuits 37 which control thirtytwo phase gates 38. The effect of this is that the thirtytwo phase gates open in turn at equal intervals (five pulse periods of the master clock, in the example described). The thirtytwo phase gates 38 also receive the master clock signal and thus open in sequence to pass this signal through to thirtytwo 6-bit digital counters 40.

These act to divide the master clock pulses

which they receive by sixtyfour. It will be seen that in the example described the first counter 40 would provide output pulses at 0, 64, 128 . . . pulse periods of the master clock; the second digital counter would provide output pulses at 5, 69, 133 . . . pulse periods om the master clock; and so on. Thus, the output of each digital counter is a pulse train at the carrier frequency and each digital counter 40 drives a corresponding transducer 42 through a buffer circuit 44 and a resonant drive circuit 46. The drive circuits are resonant power amplifiers operating at the carrier frequency. Silicon power transistors switch through pulse transformers to provide the final drive for each transducer.

In this way the relative phases of the transducer transmissions is controlled in accordance with the beam angle demand, and the phase differences have the effect of adjusting the angle of the radiation lobe of the transmitter.

If desired, the width of the pulse which opens gate 30 can be decreased, in order to permit the scan rate to be increased and to allow the vessel to travel faster while maintaining the same forward sounding spacing. However, this is achieved at the expense of depth range.

As explained above, with the curved array the selective or incremental demand for ship pitch and yaw is different for each strip. The demand is computed using signals from the ship reference platform which represent the pitch and yaw angles.

The relative phasing of the incoming signal as measured by the different transducer elements provides the angle of the returning signal with respect to the array. To reconstruct seabed contours, this angle is corrected for ship roll and is used in conjunction with range information as measured by the interval between transmission and reception of the pulse.

#### WHAT WE CLAIM IS:—

1. Sonar apparatus including a sonar transmitter having in one plane a radiation pattern made up of a number of angularly spaced lobes and further including, for correcting data derived by the sonar apparatus for pitching error when the apparatus is mounted on a ship, control means operative in response to any specific value of a control input signal to swing different lobes of the radiation pattern to different extents in a direction perpendicular to the said plane, the extent of swing of each lobe depending on the value of the control signal, whereby when the apparatus is arranged on a ship so that the said plane is perpendicular to the longitudinal axis of the ship and the lobes are downwardly directed, and when the control signal varies with the pitching angle of the ship, the amount of swing for any lobe is in the yaw direction

and varies in amount with the pitching angle so as to reduce the effect of pitching movement on the direction of transmission of the lobe.

2. Apparatus in accordance with Claim 1, including transmitter transducers which form, in the said plane, a curved array.

3. Apparatus in accordance with Claim 1, in which the transmitter includes transducers spaced along a transmitter strip extending in a direction perpendicular to the said plane, and in which the swinging of the lobes in the said direction is effected by progressively delaying the application of an energising waveform to the transducers spaced along the strip.

4. Apparatus in accordance with Claim 3, including a pulse generator, dividing means for applying to the transducers in a strip pulses at a frequency which is a sub-multiple of the frequency of the said pulse generator, and means whereby the application of the sub-multiple pulses to the different transducers along a strip is progressively delayed in order to swing the radiation patterns of the transducer strip through a beam angle dependent upon the delay between adjacent transducers.

5. Apparatus in accordance with Claim 4, in which the means for progressively delaying the application of the pulses to the transducers

includes means responsive to the pulse generator output and to the required beam angle to select from the pulse generator output pulses separated by a delay corresponding to the required beam angle, and distributor means for applying successive ones of the selected pulses to different ones of a series of gates which control, respectively, the series of transducers in a transmitter strip.

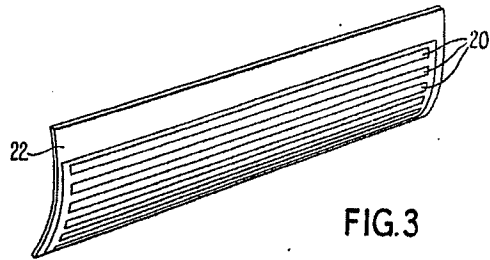
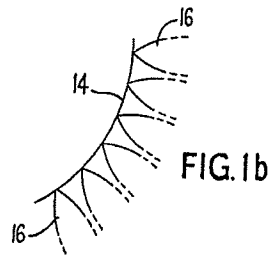
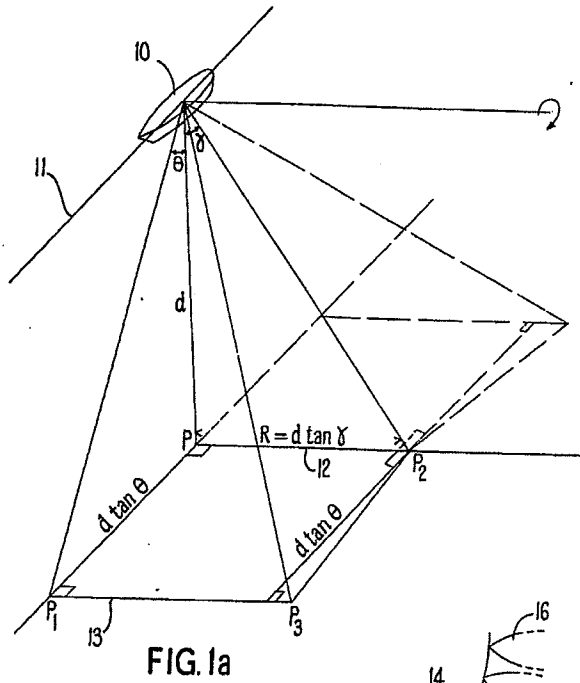
6. A waterborne craft carrying apparatus in accordance with any one of Claims 1—5, so arranged that the said lobes are angularly spaced in a plane perpendicular to the longitudinal axis of the craft and the swinging of the lobes is effected in yaw.

7. A waterborne craft in accordance with Claim 6, in which the sonar apparatus further includes means for additionally selectively rotating the radiated lobes in yaw in accordance with movement of the craft in yaw.

8. Apparatus in accordance with Claim 1, substantially as herein described with reference to Figure 4 of the accompanying drawings.

For the Applicants,  
GILL, JENNINGS & EVERY,  
Chartered Patent Agents,  
51/52, Chancery Lane, London, W.C.2.

Printed for Her Majesty's Stationery Office, by the Courier Press, Leamington Spa, 1973.  
Published by The Patent Office, 25 Southampton Buildings, London, WC2A 1AY, from  
which copies may be obtained.



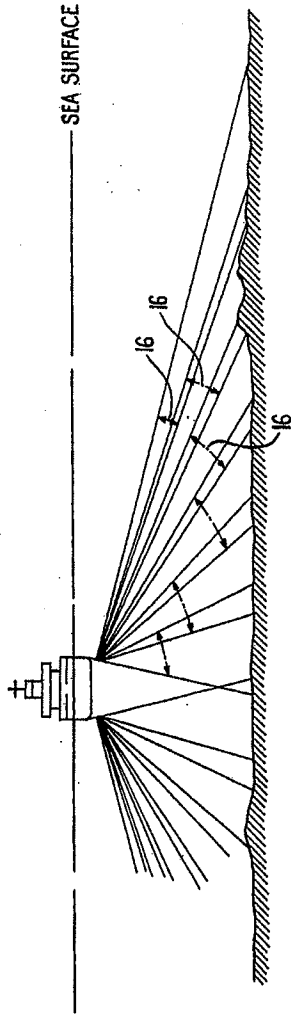


FIG. 2a

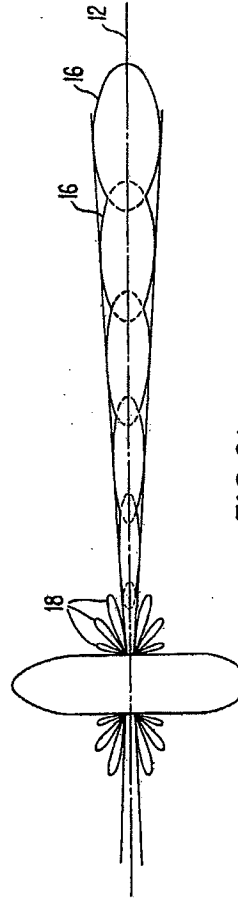
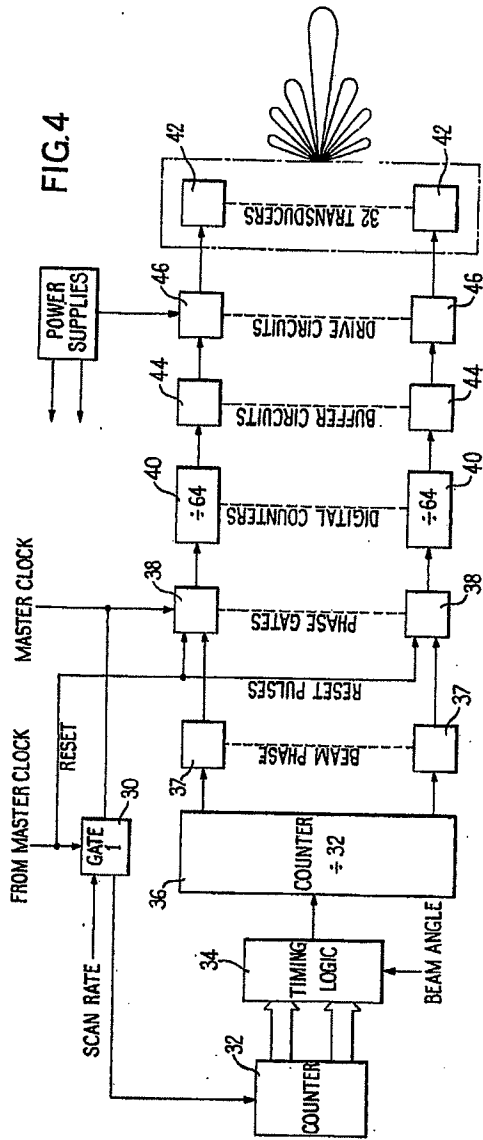


FIG. 2b





Espacenet

## Bibliographic data: JP 57046173 (A)

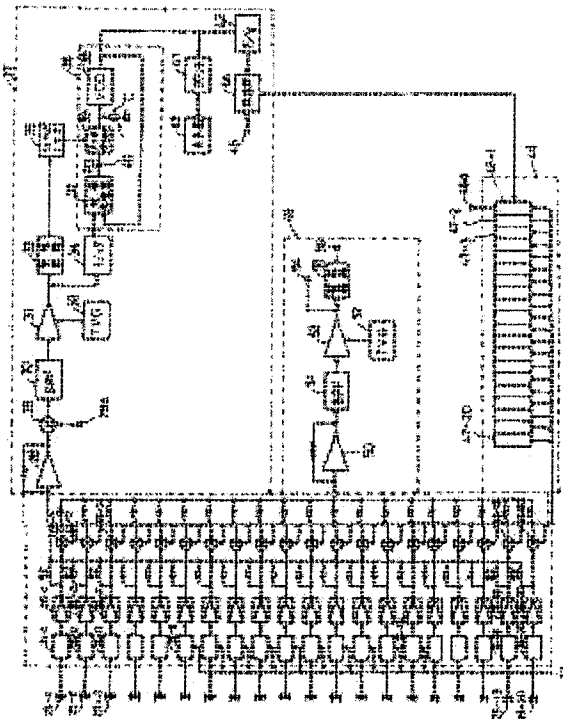
### SIDE LOOKING SONAR

**Publication date:** 1982-03-16  
**Inventor(s):** MINOHARA KIYOMI; SASAKURA TOYOKI; ENDOU YASUHIKO +  
**Applicant(s):** FURUNO ELECTRIC CO +  
**Classification:**  
- **international:** G01S15/87; G01S15/89; G01S7/52; G05D1/12; (IPC1-7): G01S15/89; G01S7/52; G05D1/08  
- **European:** G01S15/89B  
**Application number:** JP19800123215 19800904  
**Priority number (s):** JP19800123215 19800904  
**Also published as:**  
• JP 62022111 (B)  
• JP 1412157 (C)

### Abstract of JP 57046173 (A)

**PURPOSE:**To receive only the reflected wave abeam to the advancing direction all the times in the case the position of a school of fish is detected from a ship underway, by sensing the doppler shift of the reflected wave obtained by a transmitted wave, and compensating the amount of yawing.

**CONSTITUTION:**Vibrators 25-1-25-20 constituting a wave transmitting and receiving body are provided in parallel with a hull in one line. The output of the 100kHz crystal oscillator is divided, and the signals comprising 60.65kHz for display and for measuring the doppler shift are given to the vibrators 25-6-25-15 from duplexers 24-6-24-15 via a power amplifier 23. Then sonic waves having broad directivity is transmitted. The reflected waves are inputted to the vibrators 25-1-25-20 with narrow directivity, given to mixers 48-1-48-20 via the duplexers 24-1-24-20, and sent to a recorder display part 49.; A part of the input is inputted to a doppler sensing part 27, where a yawing angle is computed 44 from the sensed doppler shift and ship's speed data from a terminal 45, and the result is given to a tilt control part 46. The compensation is performed by using the output of the control part 46.



Last updated:  
12.10.2011 Worldwide  
Database 5.7.23.2; 92p



⑩ 日本国特許庁 (JP)

⑪ 特許出願公開

⑫ 公開特許公報 (A)

昭57-46173

⑬ Int. Cl.<sup>3</sup>  
G 01 S 7/52  
15/89  
G 05 D 1/08

識別記号 庁内整理番号  
7741-5 J  
7741-5 J  
7052-5 H

⑭ 公開 昭和57年(1982)3月16日

発明の数 1  
審査請求 未請求

(全 11 頁)

⑮ サイドルツキングソナー

西宮市芦原町9番52号古野電気株式会社内

⑯ 特 願 昭55-123215

⑰ 発 明 者 遠藤保彦

⑱ 出 願 昭55(1980)9月4日

西宮市芦原町9番52号古野電気株式会社内

⑲ 発 明 者 箕原喜代美

⑳ 出 願 人 古野電気株式会社

西宮市芦原町9番52号古野電気株式会社内

西宮市芦原町9番52号

㉑ 発 明 者 笹倉豊喜

㉒ 代 理 人 弁理士 東島隆治

明 細 書

1 発明の名称

サイドルツキングソナー

2 特許請求の範囲

(1)多数の振動子を、航行体の適所に一列に配列し、各振動子より斜め下方向に送出された音波の反射波を表示しつつ航行体の進行に従って水中をスキヤニングするサイドルツキングソナーにおいて、

上記振動子により受信される信号のドップラーシフト量を検出する検出手段と、この検出量と船速信号とにより航行体の進行方向に対する船首方位のずれを算出する算出手段と、この算出信号に基づいて送受信信号の総合指向性を常に設定方向に向けるように上記振動子相互の位相を制御する位相制御手段とを具備することを特徴とするサイドルツキングソナー。

(2)第1の周波数から成る所定時間幅を持つた第1の信号と、これと組になつた第2の周波数から成る微小時間幅を持つた第2の信号とを送出する

送信部と、

前記第2の信号の反射波信号に基づき水中の物標を表示する表示部とを更に具備すると共に、

前記検出手段は前記各振動子より受信される反射波信号を加算増幅する第1の増幅器及び第1の増幅器の出力中の第1の信号からドップラシフト周波数を検出するドップラシフト検出手段を有するものであり、

前記算出手段は上記第1の周波数の反射波信号のドップラシフト量と、船速信号とにより航行体の進行方向に対する船首方位のずれを算出する演算部を有するものであり、

前記位相制御手段は、前記演算部の信号に基づいて、上記第2の信号に対する振動子総合指向性を常に設定方向に向けるように上記振動子相互の位相を制御するものであることを特徴とする特許請求の範囲第1項記載のサイドルツキングソナー。

(3)前記送信部は小振幅の第1の信号部に引き続いて大振幅の第2の信号部を送信することを特徴とする特許請求の範囲第2項記載のサイドルツキ

ングソナー。

(4) 前記ドップラーシフト検出手段は

第1の信号の反射波のみを通過させる第1のバンドパスフィルタと、

前記第1のバンドパスフィルタの出力信号の周波数を測定する周波数測定手段と、

前記周波数測定手段の出力に応じてその周波数に対応する電圧を出力するF/V変換器と、を具備することを特徴とする特許請求の範囲第2項記載のサイドルッキングソナー。

(6) 前記周波数測定手段は

前記第1のバンドパスフィルタの出力を所定レベルの電圧に変換するリミッタと、

前記リミッタの出力を入力とし、前記第1のバンドパスフィルタの出力信号の有無により開閉されるアナログスイッチをローパスフィルタの素子間に挿入することによつて入力信号に等しい周波数の連続出力を得るPLL回路と、を具備することを特徴とする特許請求の範囲第4項記載のサイドルッキングソナー。

出力を加算する加算器を設け、後加算器出力を電圧制御発振器の入力としたことを特徴とする特許請求の範囲第6項記載のサイドルッキングソナー。

(8) 周波数が所定値から所定値まで連続的に変化するFM信号を発生する送信部と、

前記反射波信号のパルス幅を圧縮するパルス圧縮手段を含み、該圧縮された信号により物標を表示する表示部とを更に具備すると共に、

前記検出手段は、前記各振動子より受信される反射波信号を加算増幅する第1の増幅器及び前記第1の増幅器の出力信号に基づいてドップラーシフトを検出するドップラーシフト検出手段を有するものであり、

前記算出手段は、ドップラーシフト量と船速信号とにより航行体の進行方向に対する船首方向のずれを算出する演算部を有するものであり、

前記位相制御手段は、前記演算部の信号に基づいて振動子の総合指向性を常に検定方向に向けるように上記振動子の互の位相を制御するものであることを特徴とする特許請求の範囲第1項記載の

(6) 前記位相制御手段は、

前記演算部の信号に基づいて、各振動子毎に対して位相が少しづつずらされた信号群を発生するチルトコントロール部と、

前記チルトコントロール部の信号群を反射波信号と混合することによつて、受信部の指向方向を所定の方向に変換するミキサと、

前記ミキサの出力信号群を加算増幅する第2の増幅器と、

前記第2の信号部に対応する周波数変換された信号のみを通過させる第2のバンドパスフィルタと、を具備することを特徴とする特許請求の範囲第2項記載のサイドルッキングソナー。

(7) 前記チルトコントロール部は

位相比較器、ローパスフィルタ、電圧制御発振器を有し、位相比較器の二入力の間相で入力されるフェーズロックドループレットルを有する多数の位相制御器の各出力端子を次段の入力端子に接続して連続接続し、該各ローパスフィルタと電圧制御発振器との間にローパスフィルタと前記演算部の

サイドルッキングソナー。

(9) 前記表示部のパルス圧縮手段は一送信波に対応する一つの反射波信号を記憶できる容量を持つ記憶素子と、

送信周波数の変化に対応する軌みづけをもつて前記記憶素子の並列出力を加算するものであることを特徴とする特許請求の範囲第8項記載のサイドルッキングソナー。

## 8 発明の詳細な説明

本発明はサイドルッキングソナーにおける駆動装置の改良に関する。

船の航行中に海底の鳥獣や魚群の位置を見出すために、船の真横下方に扇形に超音波を発射してその反射波をX-Yレコーダ等に表示するサイドルッキングソナーが用いられる。サイドルッキングソナーの発音体はヨーイングによる誤表示を防止するため船に直接は取付けられず、通常船に曳航されるデュプレッサーの側部に設けられていた。そのため取扱いは複雑になる欠点があった。

本発明は発音体を船の側部に直接設け、同時に

船のヨーイングを補正することにより船表示を防止することのできるサイドルッキングソナーを提供することを目的とする。

次に第1図を参照しつつ本発明の原理について説明する。第1図において船速 $V_B$ の船がP1の位置にある場合に船首が進行方向であるY方向に正確に向いていたとすると、音波は進行方向の真横のX方向に発信される。船が位置P2においてヨーイングにより船首方向がY方向より $\theta$ だけ偏出した場合、音波の発信方向も図示のようにY方向側に $\theta$ だけずれることになる。このとき船の速度ベクトル $\vec{V}_B$ は船首方向と音波の発信方向のベクトル成分に分解することができ、夫々の大きさは $V_B \cos \theta$ 、 $V_B \sin \theta$ となる。そのため図示のP3の位置に物標があつた場合その反射波の周波数はドップラー効果によつてシフトし、そのシフト量 $f_D$ は次式で表される。

$$f_D = \frac{2V_B \sin \theta}{c} f_0 \quad \dots(1)$$

但し上式において $f_0$ は送信周波数、 $c$ は音波の水中での速度(1500m/s)である。

同時に広い指向性を有する音波を送信し、受信時にX方向からの音波を受信すべく補正している。

次に本発明の構成を実施例につき図面を参照しつつ説明する。第3図及び第4図は本発明の一実施例における夫々送信部及び受信部を示す。第3図において、発振器10は水晶による例えば100 KHzの正確な基準発振器であり、その出力は1/100分周器11を介しててい倍器12, 13, 14及び15に与えられる。てい倍器12, 13, 14, 15はPLL(フェーズロックループ)回路を含むものであつて入力1 KHzの周波数の信号を夫々5.5倍、13.5倍、6.5倍及び6.0倍にてい倍する。1/100分周器の出力は更にサイドルッキングソナーの測定レンジを切換えるレンジ切換器16に与えられる。レンジ切換器16は測定レンジの切換に対応して送信周期を定めるもので、水中での音速に対応させ例えば100 mレンジのとき134 m s, 500 mレンジのとき666 m sの周波数の信号を発生させる分周器である。パルス発生器17, 18はレンジ切換器16の出力

船のヨーイング角はせいぜい $\pm 10^\circ$ 程度であるので、 $V_B \sin \theta \approx V_B \theta$ が成立つ。これを(1)式に代入すると

$$f_D = \frac{2V_B \theta}{c} \cdot f_0$$

となり、この式は次のように変形できる。

$$\theta = \frac{c}{2V_B f_0} \cdot f_D \quad \dots(2)$$

この式において、音速 $c$ 、船速 $V_B$ 及び音波の送信周波数 $f_0$ は既知であるから、ドップラーシフト量 $f_D$ が求めればヨーイング角 $\theta$ を求めることができる。本願ではこのようにして求めたヨーイング角 $\theta$ に基づいて、第1図に破線で示すように船の進行方向から正しく $90^\circ$ 異なるX方向に補正した方向の音波を用いるものである。

サイドルッキングソナーでは送受液体1として第2図に示すように多数の振動子2-1, 2-2, ... 2-5を~~並~~列したものが用いられる。周知のようにこれらの振動子の送信時間をを微小時間づつ順次ずらせることにより所定方向に音波を送信でき、受信時間を同様はずらせれば所定方向の音波を受信することができる。本願では音波の送

に基づいて所定長のパルスを送信するものであつて例えば単安定マルチバイブレータから成る。パルス発生器17は、レンジ切換器16の出力に対応して例えば50 m s程度の十分長い幅のパルスを発生し、パルス発生器18はこの長い幅のパルスの終了と同時に例えば1 m s程度の短いパルスを発生するものである。パルス発生器17とてい倍器14の出力はアンド回路19-1に、パルス発生器18とてい倍器15の出力はアンド回路19-2に夫々与えられ、夫々の純理横出力がオア回路20に与えられる。パルス発生器17の出力は抵抗R1を介して、パルス発生器18の出力はそのまま加算器21に加えられる。オア回路20の出力は被変調信号、加算器21の出力は変調信号として変調器22に与えられる。変調器22の出力はパワーアンプ23に与えられる。パワーアンプ23の出力は送受切換器24-6~24-15を介して振動子25-6~25-15に与えられる。ここで送信時に振動子25-1~25-20のうち中間の振動子25-6~25-15のみを

用いるのは送信される音波の指向性を受信時よりもブロードにするためである。

次に第4図を参照しつつ受信部について説明する。振動子25-1~25-20は船体に平行に一行に並べられ送受波体を構成するものであつて、夫々送受切換器24-1~24-20を介してプリアンプ26-1~26-20に接続される。プリアンプ26-1~26-20の出力は夫々等しい抵抗値を持つ固定抵抗R2を介してドツプラー検出部27の増幅器28に接続される。ドツプラー検出部27は反射波の中からドツプラー効果に基づく周波数の変化を検出して船のヨーイング角 $\theta$ を求める回路であつて、その構成を以下に詳述する。増幅器28の出力はてい倍器12の出力と共にミクサー29に与えられる。ミクサー29は反射波の60 KHz及び65 KHzの信号と入力端子29より与えられるてい倍器12の55 KHzの信号を混合するもので、その出力端子には両者の和及び差の125 KHz, 5 KHz及び135 KHz, 10 KHzの信号が得られる。ミクサー29の出力は

アナログスイッチ39を設けており、このアナログスイッチ39はシュミットトリガ35の出力の有無により開閉するものである。PLL36の出力はカウンタ41及びF/V変換器42に与えられる。カウンタ41の計数値は表示器43により表示される。F/V変換器42は入力信号をその周波数に対応する電圧に変換するものであつて、その出力は次段の演算部44に送られる。演算部44には更に端子45より船速V<sub>B</sub>に対応するデータが入力されており、前述の式(2)に基づいてヨーイング角 $\theta$ が演算により求められる。演算部44のヨーイング角 $\theta$ の出力は次段のチルトコントロール部46に与えられる。チルトコントロール部46は振動子数(本実施例では20)に等しい段数を持つ位相制御器47-1~47-20を具備するものであつて、音波の受信方向をヨーイング角に応じて変えるために必要な信号を発生する。前段の位相制御器47-1には端子46を介して、てい倍器13により135 KHzの信号が加えられる。

10 KHzを通過周波数とするバンドパスフィルタ30を介して10 KHzの信号だけが増幅器31に与えられる。増幅器31はタイムバリアブルゲインコントローラ(以下TVGという。)32に基づいてその増幅度を変化させる増幅器である。TVGは遠方からの反射波信号レベルが低下するため走査時間の経過に従つて増幅度を上げるものである。増幅器31の出力は整流回路33及びリミッタ34に与えられる。整流回路33は入力信号を整流平滑するものでその出力はシュミットトリガ35に与えられる。シュミットトリガ35の方形波出力はPLL36の制御信号となる。リミッタ34は入力信号レベルを一定にするものであつてその出力はPLL36の入力端子に与えられる。PLL36はリミッタ34からの信号が与えられてロックがかかった時入力信号に等しい周波数の信号を発生するものである。PLL36は図示のように位相比較器37と電圧制御発振器(以下VCOという)38の間のローパスフィルタ40を構成する抵抗R3とコンデンサCとの間に

ここでチルトコントロール部46について第5図を参照しつつ説明する。チルトコントロール部46は本図に示すようにPLL回路を含む位相制御器47-1, 47-2~47-20の各出力端子を次段の入力端子に接続して連続接続したものである。各位相制御器は二つの入力と同相である場合にロックがかかる位相比較器111-1~111-20、ローパスフィルタ(以下LPFと略す。)112-1~112-20, VCO113-1~113-20によりPLL回路を構成しており、各ローパスフィルタと電圧制御発振器の間に加算器114-1~114-20を設けたものである。加算器114-1~114-20は演算部44より与えられるヨーイング角 $\theta$ に対応する位相信号と各LPF112-1~112-20の出力を加算して各VCO113-1~113-20の出力は次段の位相制御器47-2~47-20に伝えられると共に、出力端子46-1~46-20から取り出され第4図に示すミクサ

48-1~48-20に与えられる。ミキサ48-1~48-20は振動子25-1~25-20より得られる反射波信号とチルトコントロール部46の各出力信号とを混合するものであり、混合出力は記録表示部49の増幅器50により全て加算されて増幅される。増幅器50の出力は反射波信号の短時間部分の周波数(60 KHz付近)とチルトコントロール部46の各出力(135 KHz)の差の周波数である75 KHzを通過域周波数とするバンドパスフィルタ51に与えられる。バンドパスフィルタ51の出力はTVG52によつて制御された増幅器24に与えられて増幅される。増幅器24の出力は出力端子25を介して表示部の処理回路(図示せず)に映像信号として伝えられる。更に整流回路26にも伝えられて整流され、ペンレコーダ用出力として端子27より出力される。

次に本実施例の動作につき図面を参照しつつ説明する。第6図(a)~(d)は上記実施例の各部の波形を示すものである。第3図において発振器10の

100 KHzの出力は1/100分周器11により分周され、種いて各てい倍器12, 13, 14, 15によつて夫々てい倍されて55 KHz, 135 KHz, 65 KHz及び60 KHzの周波数の信号を発生する。1/100分周器11の出力は更にレンジ切換器16により測定レンジに対応して分周されパルス発生器17に加えられる。今測定レンジを500 mとすると同記のように666 mの周期の信号がレンジ切換器16よりパルス発生器17に加わる。第6図(a)はパルス発生器17の出力波形を示すものであつて測定レンジに対応する周期毎に所定幅のパルスを得る。このパルスの立下りに同期して第6図(b)に示すようにパルス発生器18より微小幅パルスを発生させる。これらの各パルスとてい倍器14, 15の夫々65 KHz, 60 KHzの信号とはアンプ回路19-1, 19-2に与えられ、各論理出力がオア回路20に加えられる。各パルス発生器17, 18の出力は又一定の重みづけを持つて加算器21により加算され、オア回路20の出力はこの加算器により変調される。第6図(c)は

変調器22の出力を示すものであつて、65 KHzの周波数を持つ長い小振幅信号部aにひき続いて60 KHzの周波数を持つ微小時間の大振幅信号部bから成る信号が周期的に発生する。変調器22の信号はパワーアンプ23によつて電力増幅され、送受切換器24-6~24-15を介して各振動子25-6~25-15により送信される。ここで65 KHzの信号部aはドツプラー効果による周波数のシフトを有効に検出するためある程度の時間幅(例えば50 m s)を必要とし従つてパワーアンプ23の負荷を軽減するため小振幅の信号を用いている。又60 KHzの信号部bは物標を検出するための微小幅で且大振幅の信号を用いている。

送信が時刻 $t_1$ において終了すると、送受切換器24-1~24-20は受信状態に切換えられる。以後の受信期間においては各振動子25-1~25-20より反射波信号が受信される。反射波信号は各プリアンプ26-1~26-20によつて増幅され、ドツプラー検出部27の増幅器28

により加算され増幅される。この加算された反射波信号を第6図(d)に示す。反射波信号はミキサ29に加えられて、てい倍器12の55 KHzの信号と混合される。次段のバンドパスフィルタ30は10 KHzが通過帯域であるため、反射波中65 KHzの周波数を持つ信号部aのみがバンドパスフィルタ30を介して増幅器31に加わり、増幅される。増幅された信号は第6図(e)に示すようにリミッタ34で一定レベルの信号に変換される。又整流回路33により整流、平滑されてシュミットトリガ35に加わる。第6図(f)はシュミットトリガ35の出力信号を示すものであつて信号部aに対応する反射波があつた場合にのみ信号を出力する。この信号はアナログスイッチ39の制御信号として用いられ、信号がある場合アナログスイッチ39を閉じ、信号がなくなればアナログスイッチ39を開放する。従つてリミッタ34の出力が与えられているPLL回路36において、アナログスイッチ39が閉じられた時点でPLL回路36がロックされると、PLL回路36よりリミ

ツタ34の出力と同じ周波数の信号が出力される。リミッタ34からの出力が停止した時点 $t_1$ では第6図(a)、(c)に示すようにアナログスイッチ39も同時に開放される。従つてその開放直前の電圧はローパスフィルタ40を構成するコンデンサ0により保持され、VCO38はそのまま同じ周波数で発振し続ける。第6図(c)はこの状態を示すものであり、リミッタ34より出力が得られる時刻 $t_2$ 以後リミッタ34の出力に等しい周波数の連続信号を出力する。この信号はカウンタ41に加えられてその計数値は表示器43により表示される。同時にPLL回路36の出力信号はF/V変換器42によりその周波数に対応する直流電圧信号に変換される。しかるに第1図に示すように船首がヨーイングにより進行方向Yよりヨーイング角 $\theta$ だけ傾いている場合には、物標に対する向きは速度成分により前述のようにドツプラー効果が生じる。従つて反射波信号の周波数は第6図(c)に示す信号部aに対して6.5KHzよりわずかにドツプラーシフトされた周波数の信号となる。このドツプ

ラシフトはバンドパスフィルタ30、リミッタ34を繞じてPLL回路36でもそのまま再現されているため、F/V変換器42の出力はドツプラーシフト量 $f_D$ に対応したものとなる。演算部44はこのドツプラーシフト量 $f_D$ と、端子45より与えられる船速データ $V_0$ とから、式(2)に基づいて船のヨーイング角 $\theta$ を算出する。第6図(b)は演算部44の出力を示すものであり、ヨーイング角 $\theta$ に対応する直流信号がチルトコントロール部46に与えられる。チルトコントロール部46の入力端子46aにはてい倍器13から13.5KHzの信号が与えられており、位相制御器47-1がロックするとこの周波数に等しい13.5KHzの信号が出力端子47-1より出力される。しかるに演算部44より正の信号が与えられる場合、加算器114-1によりこの信号とLPF112-1の出力が加算されてVCO113-1に与えられる。そのためVCO113-1の出力はてい倍器13より与えられる信号より位相がわずかに所定だけ進むことになる。PLL回路47-1

信することが可能となる。増幅器53はTVG52により増幅率が制御されその出力は端子54又は整流回路55を介して端子56より出力される。

以上詳細に説明したように本願発明によれば送信信号を夫々周波数の異なる小振幅長時間の信号と大振幅短時間の信号の組として構成しており、このうちの小振幅長時間の信号によつてドツプラーシフト量を検出し、それに応じて受信の指向方向を自動的に切換え、常に進行方向から真横の反射波のみを受信している。このためヨーイングによつて船の船首方向が偏向した場合であつても適切なサイドルッキング信号が得られ、商標の乱れをなくすることができる。そのため本願発明によれば従来のようにサイドルッキングソナーの送受波部のみを<sup>6</sup>搭載するデュプレッサーを曳航する必要はなく、船体の側部に直接取り付けることが可能で取扱いも容易となる。

向本実施例においては送信時に全振動子の半分だけを使用することによつて送信時の指向性を受

受信時よりブロードにしているが、受信時と同じく全振動子を用いて受信時の指向性に等しくしてもよい。その場合には受信の際と同じくドツプラーシフトから得られるドツプラー角に応じて送信方向を第1図のX軸方向になるよう制御することが必要である。

又ドツプラーシフトを測定するため本実施例においては反射波信号をPLLを用いて連続波に変換しているが、別の方法として例えば反射波信号の周期を測定する等の方法でドツプラーシフトを検出するようにしてもよい。

更に本実施例においては船に近い物標を検知するために小振幅短時間の信号に引き続いて大振幅短時間の信号を送出しているが、船に近い物標の検知が必要でなければこの順序を逆にしてもよい。

次に本発明の他の実施例につき図面を参照しつつ説明する。第7図(a)はこの実施例の送信部を示すものである。発振器10、1/100分周器11、及び135倍の倍器13については第3図のものと同様である。本実施例においてはレンジ切換器

下BB Dという)を用いたものである。本図において、クロック信号発生器65の出力に基づいて増幅器50の出力はサンプリングされ、断続的にBB D 66に与えられる。BB D 66は一送信波に対応する一反射波信号を記憶することのできる容量を持つ素子であつて、その並列出力はウェイト抵抗群67を介して加算用の増幅器68、69により加算される。ここでウェイト抵抗群67は夫々送信波の周波数偏移に対応した受信波がBB D 66の右端まで到達した時に各出力端子に現われる出力信号を加算した場合に加算出力が最大になるように定められている。より具体的には、増幅器68はリニアFM信号の正極部のみを増幅器69は負極部のみをそれぞれウェイト付加算され、両極性の信号は増幅器70で加算される。増幅器70の出力は第4図の増幅器53に与えられる。

次にドツプラー検出部27の構成については第4図に示す実施例のものと同じでよいがバンドパスフィルタ30にはリニアFM信号の周波数帯域(この実施例では60~65 KHz)を通過帯域とす

るものを用いる。このフィルタは外來の又は内部に発生するノイズを除去するために用いられる。尚本実施例においてリニアFM信号を用いたのは、設計の容易なパルス圧縮回路を用いてSN比を改善することができ、分解能も向上するからである。

次にこの実施例の動作を第8図を参照しつつ説明する。送信部においては第8図(a)に示すようにレンジ切換器16の出力に基づきのこぎり波発生器61よりのこぎり波を発生する。こののこぎり波に基づきスイープジェネレータ62は第8図(b)に示すようにリニアFM信号を発生し、振動子25-6~25-15より超音波信号が送出される。第8図(c)は反射波信号を示すものであり、送信波形に対応して直線的なFMの反射波が振動子25-1~25-20に得られる。この反射波信号にはドツプラー効果による周波数シフトが含まれている。反射波信号はプリアンプ26-1~26-20を介してドツプラー検出部27に伝えられ、バンドパスフィルタ30によりノイズ

16の出力に基づいて変化する周期毎にのこぎり波発生器61より第8図(c)に示すのこぎり波を発生させる。のこぎり波発生器61の出力は制御信号としてスイープジェネレータ62に与えられるので、スイープジェネレータ62は例えば60~65 KHz程の範囲で周波数が連続的に変化するFM信号(リニアFM信号)を出力する。この信号はプリアンプ23によつて増幅されて送受切換器24-6~24-15に与えられる。

この信号を振動子25-6~25-15より送信し、反射波を振動子25-1~25-20より受信する。本実施例においては周波数が連続的に上昇するいわゆるリニアFM信号を用いており、この信号によつてドツプラー効果によりドツプラー角 $\theta$ 及び反射波強度を検出することが必要になる。反射波強度を検出する場合には第4図に示した受信回路の記録表示部49のバンドパスフィルタ51の代りに公知のパルス圧縮回路63を用いる。第7図(b)はこのパルス圧縮回路63の一例を示すものであつてバケットブリゲード素子(以

成分が除かれる。更に反射波信号は増幅器31により増幅され、整流回路33及びリミッタ34に加えられる。第8図(a)はリミッタ34の出力を示すものであり、整形された出力は、PLL回路36に加わる。PLL回路36は前述の実施例と同じく入力信号に等しい信号を発生するが、反射波信号の終了時にはシュミットトリガ35により制御されるアナログスイッチ39の開放の所定時間前(PLL回路の時定数により定まる)の周波数の信号を連続的に発生する。第8図(b)はこのPLL回路36の出力を示すものである。このPLL回路36の出力信号はF/V変換器42によりその周波数に対応する電圧に変換される。前述のように反射波信号はドツプラー効果による周波数シフトを含むため、F/V変換器42の出力電圧はドツプラーシフト量に対応するものとなる。従って前述の実施例と同じく演算部44によりヨーイング角 $\theta$ を求め、チルトコントロール部46により順次位相の異なる信号を局発信号として発生させることにより、受信方位を定めることができ

てもよい。

#### 4. 図面の簡単な説明

第1図は本願発明の原理を示す原理図、第2図は送受波体の一例を示す構成図、第3図、第4図、第5図は本願発明の一実施例を示すブロック図であつて、夫々送信部、受信部、及びチルトコントロール部を示す。第6図(a)~(d)は第3図、第4図の各部の波形を示す波形図、第7図(a),(b)は他の実施例を示す回路図、第8図(a),(b)は他の実施例の各部の波形図である。

10…共振器、12, 13, 14, 15…てい倍器、17, 18…パルス発生器、22…変換器、23…パワーアンプ、25-1~25-20…振動子、27…ドツプラー検出部、29…ミクサ、30, 51…バンドパスフィルタ、32, 52…TVG、34…リミッタ、36…PLL回路、42…F/V変換器、44…演算部、46…チルトコントロール部、47-1~47-20…位相制御器、48-1~48-20…ミクサ、49…記録表示部、62…のこぎり波発生器、63…パルス幅

る。

次に反射波信号は更にミクサ48-1~48-20、加算増幅器50を介して第7図(b)に示すパルス幅圧縮回路63に与えられる。パルス幅圧縮回路63では反射波信号がBBD66に与えられる。BBD66に一つの反射波信号が入力された時にBBD66の並列出力を加算増幅する増幅器70は第8図(c)に示すように圧縮された出力を出し、その振幅は反射波信号の大きさに対応する。このように反射波信号の幅を圧縮し、これを映像信号として用いれば鮮明な画像が得られる。

以上のように本実施例においては二つの異なる周波数の信号を用いず、連続して周波数の変化するリニアFM信号を用いても同様にヨーイング角 $\theta$ を検出することができ、それに応じて受信の指向性が切換えられるため常に安定なサイドルッキング信号が得られる。

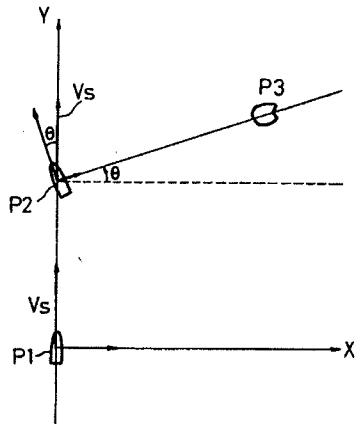
尚、本実施例においてパルス幅圧縮回路63としてBBDによるものを用いたが、同様の作用を持つものとして知られる表面波フィルターを用い

圧縮回路、66…BBD

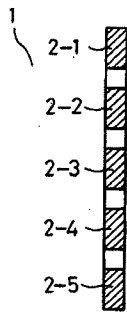
代理人弁理士 東島隆治



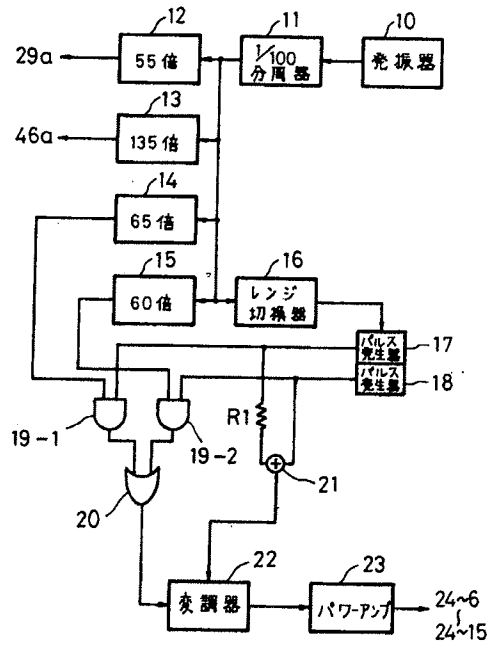
第 1 圖



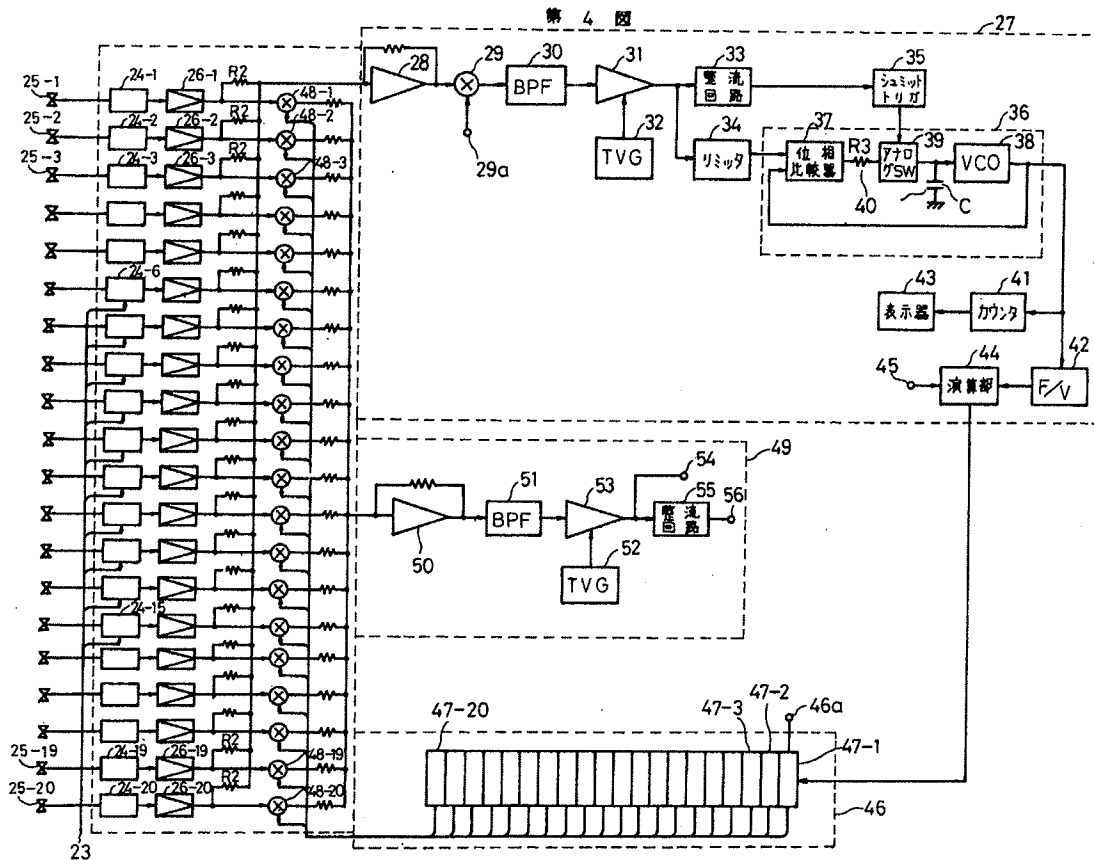
第 2 圖



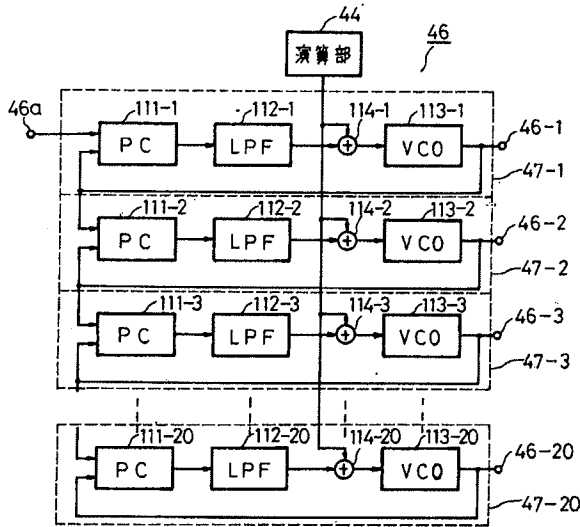
第 3 圖



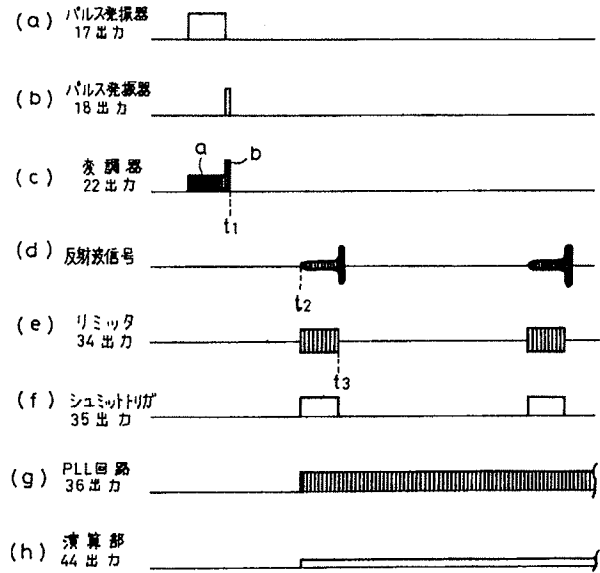
第 4 圖



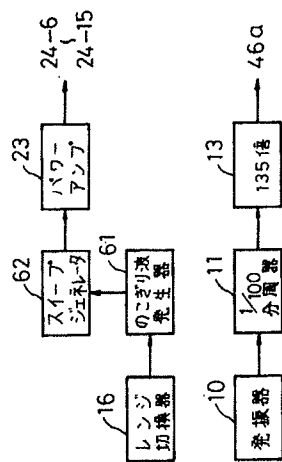
第 5 図



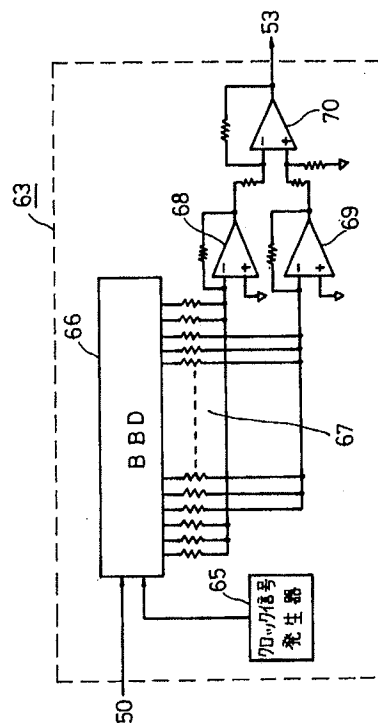
第 6 図



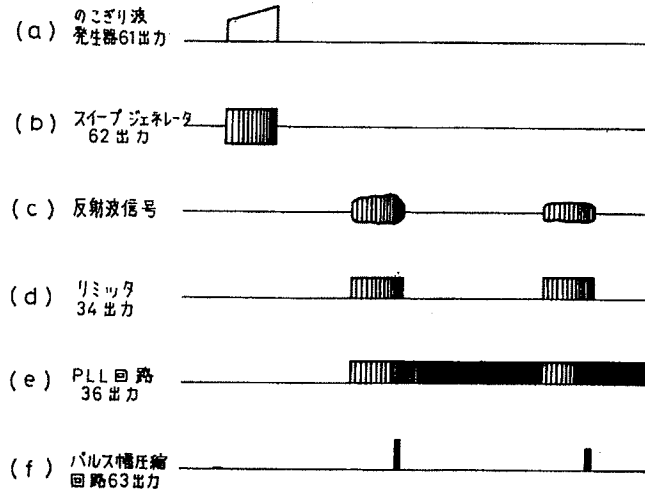
第 7 図 (a)



第 7 図 (b)



第 8 図



## Bibliographic data: JP 61116678 (A)

### UNDERWATER DETECTION DISPLAY DEVICE

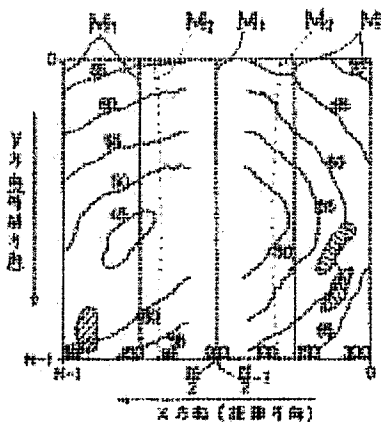
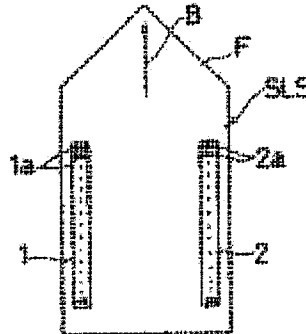
**Publication date:** 1986-06-04  
**Inventor(s):** SHIBUYA SHOZO +  
**Applicant(s):** FURUNO ELECTRIC CO +  
**Classification:**  
 - international: G01S15/89; G01S7/62; (IPC1-7): G01S15/89; G01S7/62  
 - European:  
**Application number:** JP19840239064 19841112  
**Priority number(s):** JP19840239064 19841112  
**Also published as:**

- JP 6065997 (B)
- JP 1941680 (C)

**Cited documents:** JP58079178 (A) JP57006313 (A) JP54097064 (A) [View all](#)

#### Abstract of JP 61116678 (A)

**PURPOSE:**To enable easy and accurate detection of positional relation between a ship and coastlines and dangerous obstacles in a very clear manner, by displaying a video diagonally below the water surface and a submarine topographic map in superimposition one upon another on the same screen. **CONSTITUTION:**A side looking sonar SLS has ultrasonic transmitter/receivers 1 and 2 for right and left sides on the right and left of the bottom of the hull F to allow the searching of underwater videos in a wide range below both sides of the hull F. An image signal giving a video from the SLS and an image signal from a topograph memory indicating a sea bottom topographic map are shown on the same screen of a raster-scan type display unit.; The display screen is set in the direction Y (time) and in the direction X (distance) and has  $N < 2 >$  pixels as a whole to display videos on the right and left sides separately in the rage of  $0 - (N/2 - 1)$  and in the area  $N/2 - (N - 1)$  in the direction X. Fixed markers  $M_1$  of 0, 150 and 300 (m unit) and a variable marker  $M < 2 >$  for varying display distance are provided on right and left sides respectively from the center. This enables easy and accurate determination of positional relation between the ship, coast lines and dangerous obstacles.



⑨ 日本国特許庁(JP)

⑩ 特許出願公開

⑫ 公開特許公報(A)

昭61-116678

⑮ Int. Cl.<sup>4</sup>

識別記号

庁内整理番号

⑬ 公開 昭和61年(1986)6月4日

G 01 S 7/62  
15/89

6707-5J  
8124-5J

審査請求 未請求 発明の数 1 (全11頁)

⑭ 発明の名称 水中探知表示装置

⑰ 特 願 昭59-239064

⑱ 出 願 昭59(1984)11月12日

⑲ 発 明 者 渋谷 正三 西宮市芦原町9番52号 古野電気株式会社内

⑳ 出 願 人 古野電気株式会社 西宮市芦原町9番52号

㉑ 代 理 人 弁理士 岡田 和秀

明細書

1、発明の名称

水中探知表示装置

2、特許請求の範囲

(1) サイドルッキングソナーによる船体の両側下方の映像を示す画像信号を出力する第1出力手段と、

海底地形図を示す画像信号を出力する第2出力手段と、

前記第1および第2手段から出力された画像信号に基づき、船体下方の映像と海底地形図とを、同一画面上に重ね合わせ状態で表示する表示手段と、

前記表示手段によって表示された画面上で船体からの水平距離を示すマーカとを有する水中探知表示装置。

3、発明の詳細な説明

(産業上の利用分野)

本発明は、サイドルッキングソナーを用いて船体両側下方の水中を広範囲に探査する水中探知表

示装置に関する。

(従来技術)

従来この種の装置は、サイドルッキングソナーによって探査した映像をCRTディスプレイ装置などにより表示させ、海岸線とか、岩礁や沈没船といった危険物などを映し出すように構成されていた。

(発明が解決しようとする問題点)

しかしながら、このような構成を有する従来例の場合では、海岸線や危険物の存在そのものは知ることができるものの、それらが船体に対してどのような水平距離にあるかわからず、また、岩礁などの場合には存在箇所の深さもわからず、それらの位置関係を知るために、例えば、海上保安庁などで作成した海底地形図と前述の海岸線や危険物の存在箇所とを照らし合わせて位置関係を把握しなければならず、面倒で手間がかかるとともに、正確さに欠ける欠点があった。

本発明は、このような事情に鑑みてなされたものであって、船体と海岸線や危険物との位置関係

を一目瞭然にして容易かつ正確に知ることができ  
るようにすることを目的とする。

(問題点を解決するための手段)

本発明の水中探知表示装置は、このような目的  
を達成するために、サイドルッキングソナーによ  
る船体の両側下方の映像を示す画像信号を出力す  
る第1出力手段と、海底地形図を示す画像信号を  
出力する第2出力手段と、前記第1および第2手  
段から出力された画像信号に基づき、船体下方の  
映像と海底地形図とを、同一画面上に重ね合わせ  
状態で表示する表示手段と、前記表示手段によ  
って表示された画面上で船体からの水平距離を示す  
マーカとを有するように構成する。

(作用)

つまり、サイドルッキングソナーによって得ら  
れる海岸線や危険物の存在箇所の深さを、海岸線  
や危険物が表示された位置に最も近い位置で表示  
されている海底地形図上の等深線に付された深さを  
読み取ることによって知り、そして、船体から  
の水平距離を、上述同様に海岸線や危険物の表示

れている。そして、 $x$ 方向および $y$ 方向いずれにも  
 $N$ 個の画素数を、即ち、全体として $N^2$ 個の画素  
数を有し、 $x$ 方向の $0 \sim (N/2 - 1)$ に右舷側の  
映像が表示されるとともに、 $y$ 方向の $N/2 \sim (N - 1)$   
に左舷側の映像が表示されるようになって  
いる。

前記表示画面においては、その左右中央を船体  
 $F$ が航行するものと設定されるとともにその表示  
範囲 $Dp(m)$ (船体からの直線距離)が $300m$ に設定さ  
れ、中央から左右両側夫々に「0」、「150」、「300」(単  
位 $m$ )の固定用のマーカ $M_1, \dots$ が付され、かつ、表  
示距離を変更可能な可変用のマーカ $M_1', M_2'$ が付  
されている。ここでは、可変用のマーカ $M_1', M_2'$   
が、船首方向 $B$ に直交する方向の水平距離が $100m$   
の位置を表示している。

第4図は、前記サイドルッキングソナー(SLS)  
による映像を示す画像信号を出力する第1出  
力手段 $T$ 、海底地形図を示す画像信号を出力する  
第2出力手段としての地形メモリ $12$ 、ならびに、  
両出力手段 $T, 12$ による画像信号に基づく映像

位置に最も近い位置のマーカの目盛りを読み取る  
ことによって知り、船体からの位置関係を把握す  
るのである。

(実施例)

以下、本発明を図面に示す実施例に基づいて詳  
細に説明する。

第1図はサイドルッキングソナー(SLS)の取  
付構成を示す平面図であり、船体 $F$ の底面の左右  
両側に左舷用超音波送受波器 $1$ と右舷用超音波送  
受波器 $2$ とが設けられ、両超音波送受波器 $1, 2$   
夫々が、各1個の振動子 $1a, \dots, 2a, \dots$ を船首方  
向 $B$ に並設して構成され、第2図に示すように、  
船首方向 $B$ に $\phi(L)$ 、左右両側夫々において船首  
方向 $B$ に直交な方向に $\theta(L)$ の送受波ビームを形  
成し、船体 $F$ の左右両側夫々の下方の広い範囲の  
水中の映像を探索できるように構成されている。

第3図は、表示手段としてのラスタースキャン  
(直交座標)型の表示器 $25$ による表示画面の一例  
を示し、この表示画面としては、縦方向(時間方  
向)を $y$ 方向、横方向(距離方向)を $x$ 方向に設定さ

を表示器 $25$ の同一画面上に重ね合わせ表示する  
表示手段を示すブロック回路図である。

前記第1出力手段 $T$ は、左右両側の送受波器 $1, 2$   
夫々に送信のための増幅出力を出す送信アンプ  
 $3, 4$ 、および、受信した画像信号を増幅出力す  
る受信アンプ $5, 6$ から構成され、送信アンプ $3, 4$   
は、 $\gamma$ カウンタ $36$ の出力するトリガパルスに  
より予め定められたパワー、パルス幅および周波  
数の超音波パルス信号を送受波器 $1, 2$ を通して  
水中に発射させるようになっている。水中の物体  
から反射された探知信号は送受波器 $1, 2$ で受信  
され、受信アンプ $5, 6$ で増幅検波される。受信  
アンプ $5, 6$ に入力されているトリガパルスは探  
知信号の距離による減衰を補正するためのTVG  
用に使用される。

前記第1出力手段 $T$ からの探知信号は切り換え  
器 $7$ とA/D変換器 $8$ を介して信号メモリ $9$ に入  
力され、この信号メモリ $9$ において一画面表示分  
即ち $N$ 回送信分のサイドルッキングソナー(SLS)  
探知信号を記憶する。したがって、信号メモ

リ9の記憶容量はA/D変換器8の出力ビット数を $\alpha_1$ とすると、 $\alpha_1 \times N \times N$ となる。信号メモリ9としてはRAMが使用される。信号メモリ9のy方向番地およびx方向番地は、いずれも0~(N-1)である。一回の送信毎にカラー魚探と同様にx方向に一行分の信号が書き込まれ、0~(N/2-1)に送受波器2で受信した右舷の画像信号が書き込まれ、N/2~(N-1)に送受波器1で受信した左舷の画像信号が書き込まれる。

両送受波器1,2の探知信号は2進カウンタ37の指令入力により前記切り換え器7で切り換えられ、その切り換えに伴うx方向番地の切り換えは同じく2進カウンタ37の指令入力を受けて切り換え器34で行なわれる。信号メモリ9には $\gamma$ カウンタ36の計数値が1変化する間に左右舷の信号を各1回書き込めばよいので2進カウンタ37の計数値が0の時2進カウンタ37の出力は"L"となって右舷の信号が書き込まれ、また、計数値が1の時には出力が"H"となって左舷の信号が書き込まれる。

なお、 $\gamma$ カウンタ36はN/2進アップカウンタであり、比較器38はDp/N(m)を超音波が往復するのと等しい時間間隔の一致パルスを出力する。35は、N進ダウンカウンタで構成される $\gamma$ カウンタであり、 $\gamma$ カウンタ36の出力するトリガパルスを計数し、切り換え器10,13を介して信号メモリ9および前記地形メモリ12のy方向書き込み位置を出力するようになっている。

前記地形メモリ12のy方向番地およびx方向番地はいずれも0~(N/2-1)であり、信号メモリ9と同様に一回の送信毎にx方向一行分の等深線が書き込まれ、0~(N/2-1)に右舷の等深線が、そして、N/2~(N-1)に左舷の等深線が夫々書き込まれるようになっている。地形メモリ12には、等深線用の海底深度D(m)とマークM<sub>i</sub>用に水平距離(船体Fから船首方向に直交する水平方向の距離)H(m)が書き込まれる。なお、図定用マークM<sub>i</sub>の表示手段についての説明は省略した。したがって、地形メモリ12の記憶容量は、海底深度と水平距離との合計ビット数を $\alpha_2$ とす

ると、 $\alpha_2 \times N \times N$ となる。この地形メモリ12にはRAMが使用される。

次に、前記地形メモリ12に海底地形図を書き込む手法について説明する。

まず、海底地形図の等深線上にディジタイザの位置検出部をセットし、海底地形図の原点からの距離(東西方向および南北方向、単位mm)を読み取り、そのディジタイザに接続されたコンピュータにより上記原点からの距離、地形図の縮尺および地形図の原点位置(N<sub>s</sub>, E<sub>s</sub>)を使用し、海底地形図より等深線の位置(緯度N、経度E)を求める。

地形図上の等深線には等深線番号jが付けられており、1の等深線から順々に等深線上の位置が求められる。1つの等深線の端から等深線に沿って予め定められた間隔で等深線上の位置(N<sub>jk</sub>, E<sub>jk</sub>)が求められる。ここでkは1からK<sub>j</sub>までの数である。K<sub>j</sub>は等深線番号jの等深線における位置サンプル数(位置読み取り数)である。求められた等深線上の位置(N<sub>jk</sub>, E<sub>jk</sub>)は、例えば、第6図に示すようなテーブルを用いて、K<sub>j</sub>、等深線の

深度D<sub>j</sub>、等深線数Lとともに磁気テープ、RAM、磁気ディスク、磁気バブルなどの各種記録媒体に記憶される。

コンピュータは、第5図に示すように、CPU101、RAM102、ROM103、入力装置104、出力装置105から構成される。出力装置105は4個のラッチ106,107,108,109とデコーダ111から構成され、記録媒体に記憶された等深線を地形メモリ12に書き込むようになっている。

CPU101はROM103に内蔵されているプログラムにより演算、判定、データの転送などを行なうようになっている。

RAM102は、入力装置104から入力された測定信号の記憶、CPU101の演算結果および判定結果などを記憶するようになっている。

また、記録媒体から船体F付近の等深線を読み出して記憶するようになっている。

ROM103はプログラムおよび定数値を記憶するようになっている。

入力装置104には、方位測定装置112、測位装置113、記録媒体としての磁気テープ114および表示範囲設定器41夫々の出力が接続されている。

次に、等深線図作成の動作につき、第7図のフローチャートを用いて説明する。

CPU101にγカウンタ36の出力するトリガパルスが入力されたかどうかを判断し(ステップN1)、入力されたと判断すれば、今から等深線を書き込むγカウンタ35の計数値の示す地形メモリ2のγ方向番地のx=0から(N-1)までの記憶内容を消去する(ステップN2)。次いで、第8図および第9図に示すように、入力装置104から船体F自身の位置(N<sub>0</sub>, E<sub>0</sub>)と、北方向に対する船首方向Bの角度θおよび表示範囲Dp(m)とを読み取り、船体Fから船首方向Bに直交する方向の水平距離Dp(m)の点a, bの位置、点P<sub>i</sub>(N<sub>a</sub>, E<sub>a</sub>), 点P<sub>i</sub>(N<sub>b</sub>, E<sub>b</sub>)を求める(ステップN3)。点a, bはRAM102から点a, bを通る等深線をさがし出すために使用される。Dpは本来直線距離

であるが、水平距離でDpの範囲の等深線をさがしておけば、直線距離Dpの範囲内を十分カバーできる。

次に、j=1とする(ステップN4)。

そして、k=1、V<sub>j0</sub>=0とした(ステップN5)後、等深線サンプル位置(N<sub>jk</sub>, E<sub>jk</sub>)のU-V座標上の位置(U<sub>jk</sub>, V<sub>jk</sub>)を求める(ステップN6)。この(U<sub>jk</sub>, V<sub>jk</sub>)は、下記式により求める。

即ち、U-V座標とN-E座標との関係は、0点を船体Fの位置とした場合、0点のU-V座標およびN-E座標の値は夫々(0, 0)、(N<sub>0</sub>, E<sub>0</sub>)となる。したがって、

$$U = (E - E_0) \times \cos \theta \times \cos N_0 \times \beta - (N - N_0) \times \sin \theta \times \beta$$

$$V = (E - E_0) \times \sin \theta \times \cos N_0 \times \beta + (N - N_0) \times \cos \theta \times \beta$$

$$N = [(V \times \cos \theta - U \times \sin \theta) / \beta] + N_0$$

$$E = [(V \times \sin \theta + U \times \cos \theta) / (\beta \times \cos N_0)] + E_0$$

ただし、β = 60 × 1852 (1分が1マイル)

となり、上記U, Vより(U<sub>jk</sub>, V<sub>jk</sub>)を求めれば良い。

また、前述のa点の位置(N<sub>a</sub>, E<sub>a</sub>)およびb点の位置(N<sub>b</sub>, E<sub>b</sub>)夫々は、上記式に基づき、下記のようにして求められる。

$$N_a = N_0 - Dp \times \sin \theta / \beta$$

$$E_a = E_0 + Dp \times \cos \theta / (\beta \times \cos N_0)$$

$$N_b = N_0 + Dp \times \sin \theta / \beta$$

$$E_b = E_0 - Dp \times \cos \theta / (\beta \times \cos N_0)$$

次に、U軸上を通過する等深線があるかどうかを判断し(ステップN7)、あると判断すれば、そのU軸上の値を地形メモリ2のx方向上の値に変換して書き込む(ステップN8)。

前記ステップN7において、V<sub>jk</sub>=0でないと判断した場合には、連続する等深線サンプル位置のV<sub>jk</sub>の正負の符号が今回と前回とで同じかどうかを判断し(ステップN9)、同じで無いと判断した時、即ち、等深線がU軸を横切った時には、前述の場合と同様にして、そのU軸上の値を地形メモリ2のx方向上の値に変換して書き込む(ステッ

プN10)。

前記ステップN8およびステップN10に供する、表示メモリ上の位置X<sub>mjk</sub>とU<sub>jk</sub>およびV<sub>jk</sub>との関係を示す関係式について、次に説明しておく。

(i) V<sub>jk</sub>=0の時

$$H_{jk} = U_{jk}$$

$$X_{mjk} = \pm R \times I / Dp \times N / 2 + N / 2$$

ただし、R<sup>2</sup> = D<sup>2</sup>j + H<sup>2</sup>jkであり、そして、H<sub>jk</sub>が正の時は一、負の時は一である。

(ii) V<sub>jk</sub>≠0の時

$$H_{jk} = -(U_{jk} - U_{j(k-1)}) \times |V_{jk}| / (|V_{jk}| + |V_{j(k-1)}|) + U_{jk}$$

$$X_{mjk} = \pm R \times I / Dp \times N / 2 + N / 2$$

上記(i)(ii)において、0 ≤ X<sub>mjk</sub> ≤ (N-1)である。

信号メモリ9および地形メモリ2夫々への書き込みは、クロックパルス発生器cp50の出力パルスが“H”の時に行なわれ、そして、“L”の時には読み出しが行なわれる。地形メモリ2への書



き込みは、CPU101によりx方向書き込み位置Xijkがラッチ108に、Djがラッチ106に、IHjkがラッチ107に夫々セットされた後、CPU101によりフリップフロップF/F15がセットされ、更にフリップフロップF/F15がセットされたその後の最初のMS(不安定マルチバイブレータ)44の出力パルスにより行なわれる。なお、この時、第10図のタイミングチャートに示すように、y方向番地はyカウンタ35により出力される。ステップN2における記憶内容の消去時にはIHjkとDjがともに0となる。

前記ステップN8およびステップN10を経た後、ならびに、ステップN9で正負の符号が同じと判断された時には、 $k=k+1$ としてから(ステップN11)、 $k=Kj$ かどうかを判断し(ステップN12)、 $k=Kj$ で無いと判断すればステップN6に戻し、逆に $k=Kj$ と判断すれば、 $J=J+1$ とした(ステップN13)後、 $j=l$ かどうかを判断する(ステップN14)。ここで、 $j=l$ で無いと判断すれば、ステップN5に戻し、そして、 $j=$

16はROMであり、ここに地形メモリ12の出力Dが入力され、その入力値にしたがって、例えば、第11図の設定値テーブルT<sub>1</sub>に示すようにあらかじめ定められた値を出力する。この設定値テーブルT<sub>1</sub>によれば、5m毎の等深線が異なる10色で表示されるようになっている。

43は可変マーカ設定器であり、水平距離Phv値(単位m)を出力するようになっている。比較器17には上記水平距離Phv値と地形メモリ12の出力Hとが入力されており、この2つの値が一致した時、可変マーカが可変マーカ値表示器42により表示される。可変マーカ値表示器42はLED、液晶などによって数値を表示するようになっている。

14はAND回路、15はフリップフロップ、32、33は加算器、39はカウンタ、40はROMである。

21は色変換ROMであり、地形メモリ12からの出力をROM16およびラッチ18を介して入力するとともに、信号メモリ9からの出力をラッ

シと判断すればステップN1に戻す。

以上のようにして、等深線図の作成を終了する。前記クロックパルス発生器cp50の出力パルス周期は表示器上で一画素を表示する時間と等しく、またパルスのデューティは50%である。

信号メモリ9および地形メモリ12に記憶されている信号はクロックパルス発生器cp50のパルスが“L”になる毎に、信号の書き込み中あるいは等深線図書き込み中にかかわらず1つずつ読み出され、表示器25に表示される。そしてその読み出し番地はxカウンタ49およびyカウンタ48の計数値により決定される。

xカウンタ49およびyカウンタ48の計数値は表示器25の各画素と対応しているの、xカウンタ49はN進アップカウンタであり、またyカウンタ48もN進アップカウンタである。11は加算器であり、yカウンタ35の計数値が示す信号メモリ9および地形メモリ12のy方向最新探知信号番地の信号を画面の上端に表示するようになっている。

チ19を介して入力し、かつ、可変マーカ設定器43からの出力を比較器17およびラッチ20を介して入力し、それらの入力に基づき、D/A変換器22、23、24夫々を介して表示器25に所定の表示を行なわせるように構成されている。

26はy偏向コイル、27はx偏向コイル、28はy偏向アンプ、29はx偏向アンプである。

なお、第4図および第5図で示す回路の夫々の入力端子に付した記号について説明しておく。

#### (i)RAM、ROM

A:アドレス入力または出力

D:データ入出力

Di:データ入力

Do:データ出力

R/W:読み書き制御入力(“H”の時に書き込み状態となる)

#### (ii)カウンタ

CK:クロック入力(入力パルスの立ち上がりで動作)

C:桁上げ出力

- CLR:リセット入力  
 Do:計数出力  
 (iii)ラッチ  
 Di:データ入力  
 Do:データ出力  
 CK:クロック入力(入力パルスの立ち上がりで動作)  
 (iv)フリップフロップ(F/P)  
 S:セット入力(入力パルスの立ち上がりで動作)  
 R:リセット入力(入力パルスの立ち上がりで動作)  
 Q:Q出力(セットされると"H"になる)  
 (v)単安定マルチバイブレータ(MS)  
 CK:クロック入力(入力パルスの立ち上がりで動作)  
 Q:Q出力  
 (vi)切換器  
 C:コントロール入力("H"の時"ON"になる)

(効果)

以上のように、本発明の水中探知表示装置によれば、サイドルッキングソナーによって映し出される映像と海底地形図とを同一画面に重ね合わせ表示するから、ひとつの画面を見ることによって、海岸線や危険物の船体からの水平距離、および、それらの深さといった船体からの位置関係を一目瞭然にして知ることができ、サイドルッキングソナーによる映像と海底地形図とを交互に見比べて位置関係を知るような手間をかけずに済み、かつ、海岸線や危険物の映像そのものから目を離さずに深さや水平距離を読み取ることができ、海岸線や危険物と船体との位置関係を容易にかつ正確に把握できるようになった。その結果、従来に比べてより一層航行を安全にかつ楽に行なえるようになった。

#### 4、図面の簡単な説明

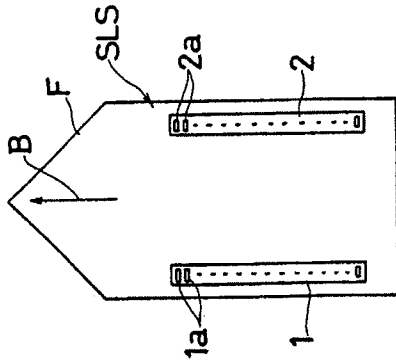
図面は本発明の実施例を示し、第1図は、サイドルッキングソナーの取付構成を示す平面図、第2図はサイドルッキングソナーの探知範囲を示す

斜視図、第3図は表示画面の例示図、第4図および第5図はブロック回路図、第6図は等深線上の位置を示すテーブルの例示図、7図はフローチャート、第8図および第9図は、夫々N-E座標とU-V座標との相関を示す図、第10図はタイミングチャート、第11図は設定値テーブルを示す図である。

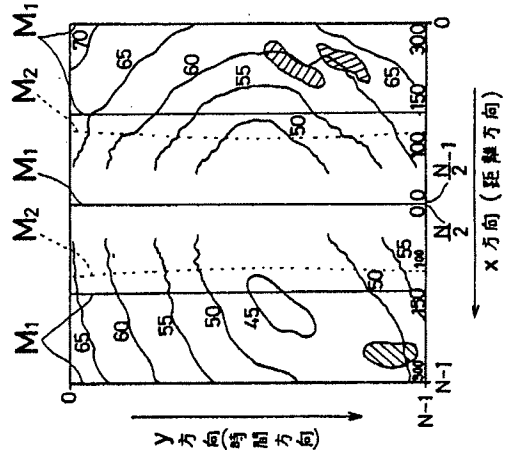
図中、符号12は第2出力手段、Fは船体、SLSはサイドルッキングソナー、Tは第1出力手段、M<sub>1</sub>、M<sub>2</sub>はマークである。

出願人 古野電気株式会社  
 代理人 弁理士 岡田和秀

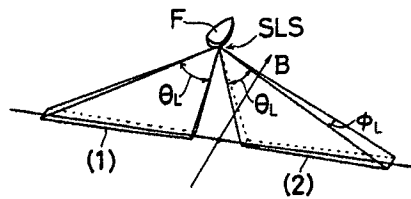
第 1 図



第 3 図

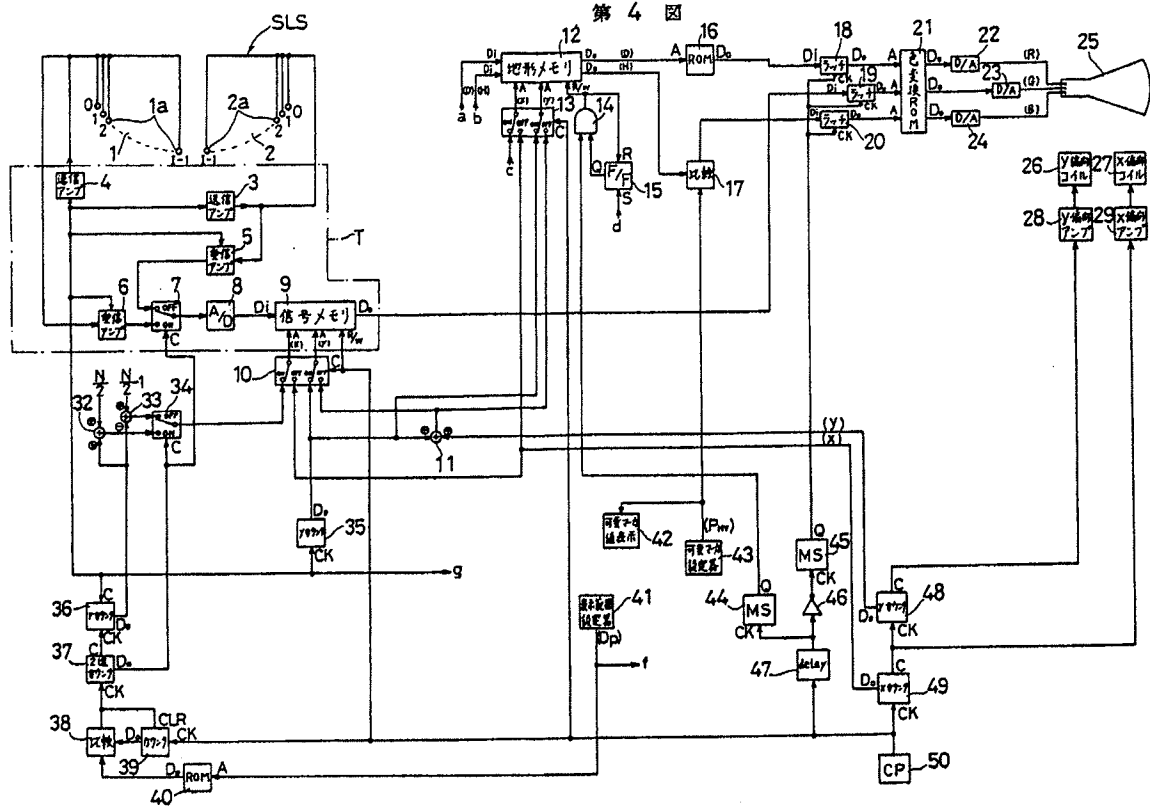


第 2 図

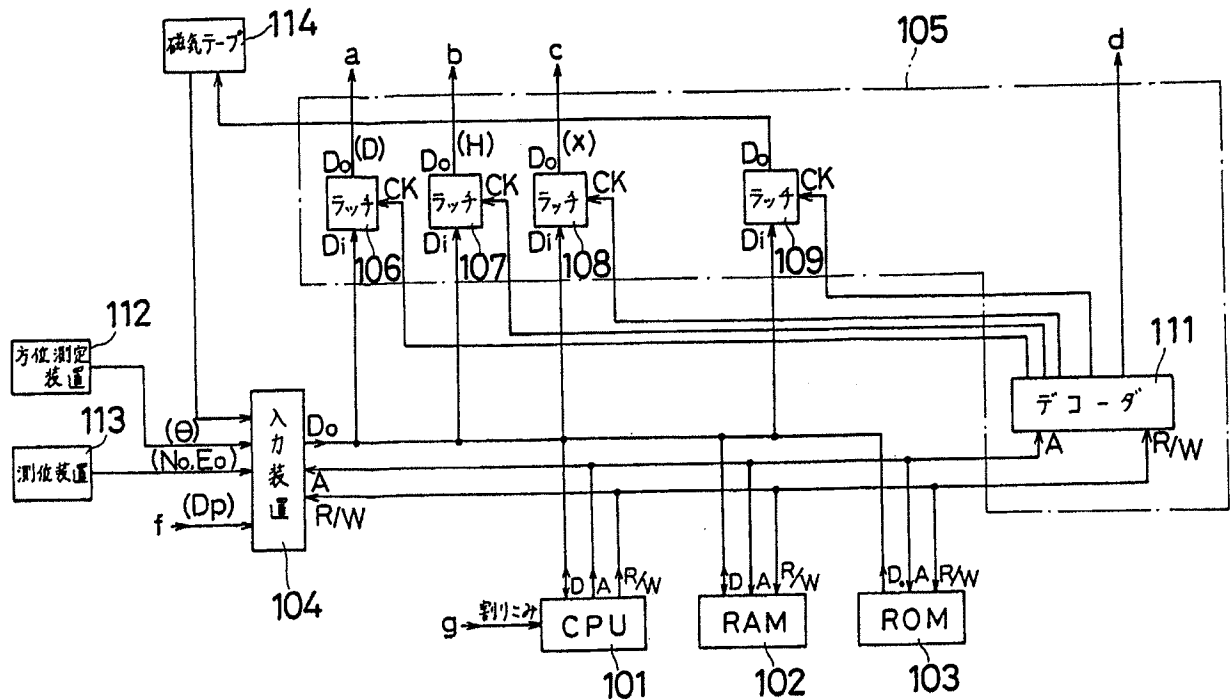


第 6 図

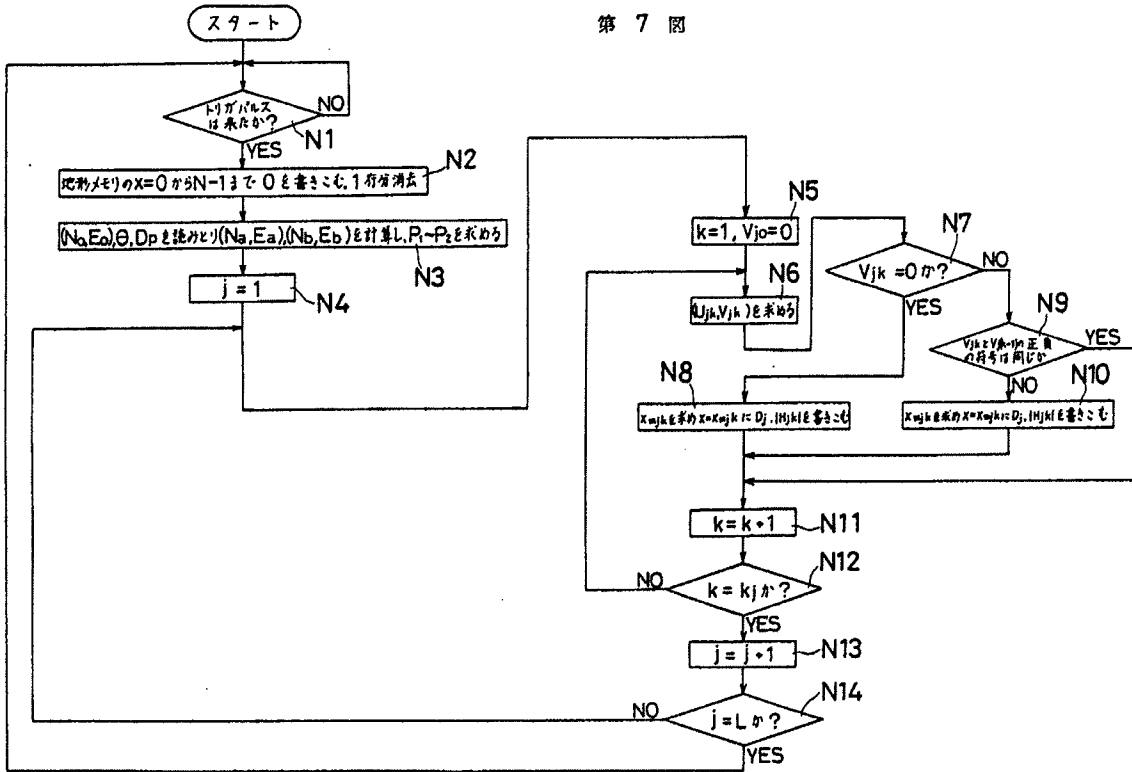
等深線 番号(J)	深度 (D)	サナル値 (K)	等深線サナル値 (M, E, S)							298	299	300
			1	2	3	4	5	6	7			
1	m											
2												
3												
4												
5												
6												
7												
8												
9												
10												
11												



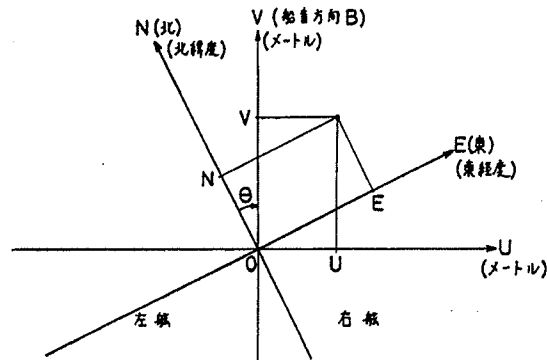
第5図



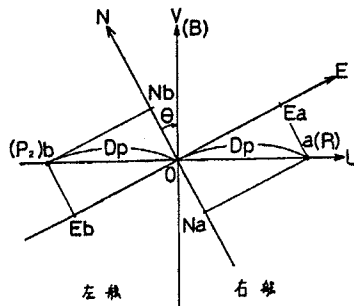
第7図



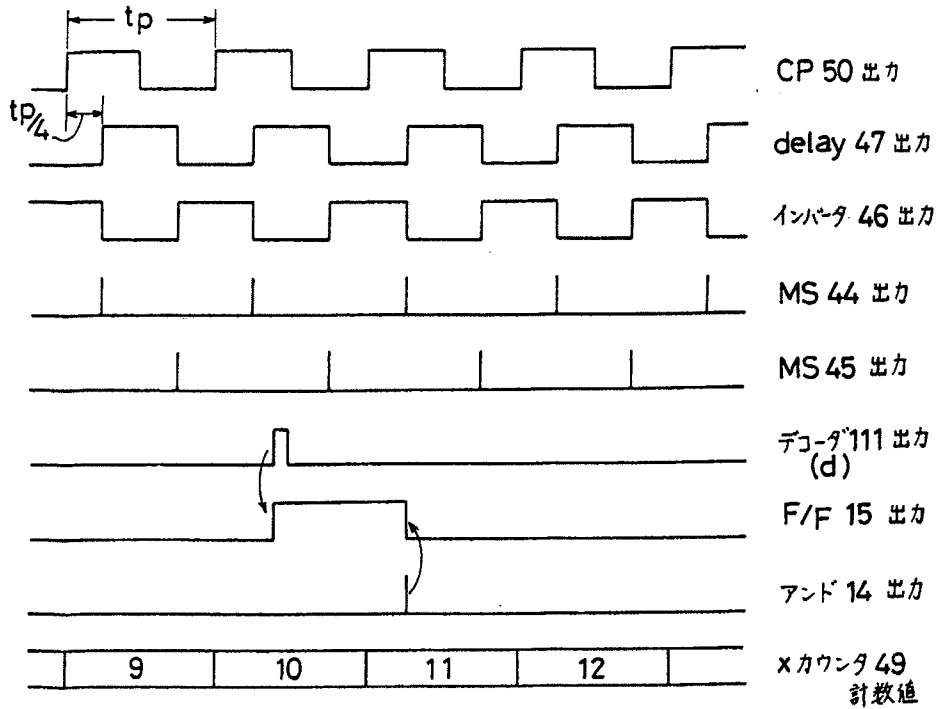
第8図



第9図



第 10 図



第 11 図

Dの値の下2桁	出力値
4 ~ 6 , 54 ~ 56	1
9 ~ 11 , 59 ~ 61	2
14 ~ 16 , 64 ~ 66	3
19 ~ 21 , 69 ~ 71	4
24 ~ 26 , 74 ~ 76	5
29 ~ 31 , 79 ~ 81	6
34 ~ 36 , 84 ~ 86	7
39 ~ 41 , 89 ~ 91	8
44 ~ 46 , 94 ~ 96	9
49 ~ 51 , 99 ~ 01	10
上記以外	0(無色)

T1

手 続 補 正 書 (自 発)

昭和 60 年 9 月 4 日

特許庁長官

殿

1、事件の表示

昭和 59 年特許願第 239064 号

2、発明の名称

水中探知表示装置

3、補正をする者

事件との関係 特許出願人

住 所 兵庫県西宮市芦原町 9 番 52 号

名 称 古野電気株式会社

代表者 古野 清 孝

4、代理人

住 所 大阪市北区浪花町 13 番 38 号千代田ビル北館

電 話 (06) 376-0857

氏 名 弁理士(8673) 岡田 和 秀

5、補正命令の日付 自発補正

6、補正により増加する発明の数

なし

7、補正の対象

明細書の特許請求の範囲の欄、

明細書の発明の詳細な説明の欄

方 式 小 査



8、補正の内容

- (1)特許請求の範囲を別紙の通りに補正する。
- (2)明細書の第1頁、第20行目の「船体両側下方の」を「水面から斜め下方の」に訂正する。
- (3)同第3頁、第6行目の「船体の両側下方の」を「水面から斜め下方の海底」に訂正する。
- (4)同第3頁、第9行目の「船体下方の」を「上記斜め下方の海底」に訂正する。
- (5)同第20頁、第1行目の「(効果)」の前に、次の文を挿入する。

「前記両超音波送受波器1、2としては、船体Fに直接装備するものに限らず、船体Fに曳航される曳航体に装備するものでも良い。なお、この場合、船体Fと曳航体との位置ずれの修正は、船体Fに対する曳航体の方向と両者間の水平距離とにより補正を加え、船体Fからの水平距離を示すようにすれば良い。」

9、添付書類の目録

- (1)補正後の特許請求の範囲 1通

特許請求の範囲

- (1)サイドルッキングソナーによる水面から斜め下方の海底映像を示す画像信号を出力する第1出力手段と、

海底地形図を示す画像信号を出力する第2出力手段と、

前記第1および第2手段から出力された画像信号に基づき、上記斜め下方の海底映像と海底地形図とを、同一画面上に重ね合わせ状態で表示する表示手段と、

前記表示手段によって表示された画面上で船体からの水平距離を示すマーカとを有する水中探知表示装置。

## Bibliographic data: JP 4357487 (A)

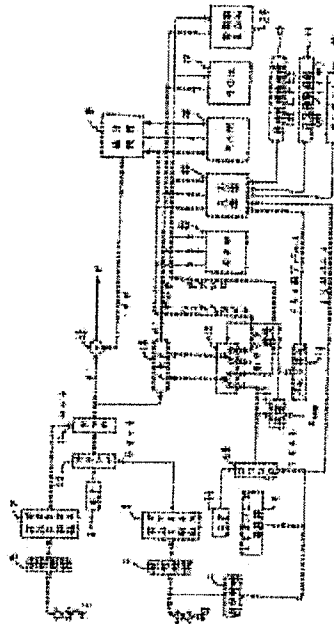
### SIDE LOOKING SONAR

**Publication date:** 1992-12-10  
**Inventor(s):** MORIMATSU HIDEJI; SHIBUYA SHOZO +  
**Applicant(s):** FURUNO ELECTRIC CO +  
**Classification:**  
 - international: G01S15/89; (IPC1-7): G01S15/89  
 - European:  
**Application number:** JP19910172240 19910712  
**Priority number(s):** JP19910172240 19910712; JP19900212189 19900810

### Abstract of JP 4357487 (A)

**PURPOSE:** To measure the position of an object under water accurately by a method wherein a phase difference is determined at input points of two receivers with respect to a measuring point by calculation and a phase difference is measured with two receivers for the same measuring point to obtain a deviation of phase so that the phase difference measured is corrected by the deviation of phase.

**CONSTITUTION:** When a trigger pulse from a trigger pulse generator 3 is inputted into a CPU21 through an input device 22, a measuring position of own ship and the bearing of navigation are read in form a highly accurate position measuring device 23 and a bearing measuring device 24 to determine an intersection with a contour line based on the value and a probing range inputted from a keyboard 25 beforehand. Distances are determined from the centers of receivers R1 and R2 to the sea surface below the intersection to obtain a phase difference  $\phi_1$  corresponding thereto. A phase difference  $\phi_2$  is measured between two receivers for the same measuring point to obtain  $\phi_1 - \phi_2 = d\phi$  as deviation of phase between the two receivers. The phase difference measured actually thereafter is corrected by the deviation  $d\phi$  of phase to remove the deviation of phase difference generated between two receiving systems thereby measuring the position of an object under water accurately.



Last updated:

12.10.2011 Worldwide Database 5.7.23.2; 92p



(19)日本国特許庁 (J P)

(12) 公開特許公報 (A)

(11)特許出願公開番号

特開平4-357487

(43)公開日 平成4年(1992)12月10日

(51)Int.Cl.<sup>5</sup>  
G 0 1 S 15/89

識別記号 庁内整理番号  
A 8113-5 J

F I

技術表示箇所

審査請求 未請求 請求項の数2(全11頁)

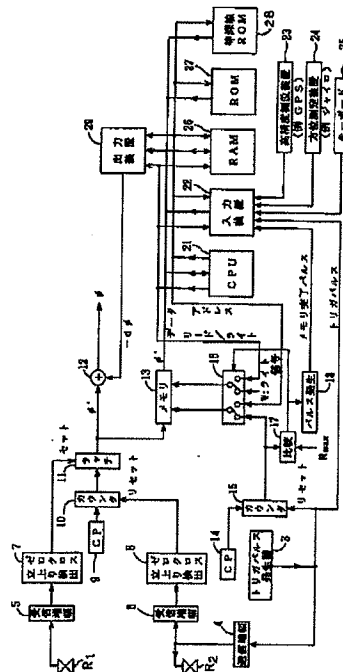
(21)出願番号	特願平3-172240	(71)出願人	000166247 古野電気株式会社 兵庫県西宮市芦原町9番52号
(22)出願日	平成3年(1991)7月12日	(72)発明者	森松 秀治 兵庫県西宮市芦原町9番52号 古野電気株式会社内
(31)優先権主張番号	特願平2-212189	(72)発明者	渋谷 正三 兵庫県西宮市芦原町9番52号 古野電気株式会社内
(32)優先日	平2(1990)8月10日	(74)代理人	弁理士 青山 葆 (外1名)
(33)優先権主張国	日本 (J P)		

(54)【発明の名称】 サイドルツキングソナー

(57)【要約】

【目的】 2つの受信系間で生じ位相のずれをなくして正確な水中探知を可能にする。

【構成】 予め正確に測定されたある測定点に対し、計算により、2つの受波器の入力点での位相差 $\phi$ を求めておき、そして同じ測定点に対して2つの受波器により位相差 $\phi'$ を測定し、 $\phi' - \phi = d\phi$ を2つの受信系間での位相のずれとして、これ以降に実際に測定した位相差をこの位相のずれ $d\phi$ で補正することにより、2組の受信系間で生じる位相差のずれを除去して水中物体の位置を正確に測定する。



1

## 【特許請求の範囲】

【請求項1】 鉛直線に対し所定角を形成する直線上の所定距離離れた位置に設けられた一対の第1および第2の受波器を備え、いずれか一方の受波器より、垂直方向に広くて水平方向に狭い送波ビームを形成し、前記ビームのエコーを第1及び第2の受波器で捕捉し、これら第1および第2の受波器にそれぞれ接続される第1および第2の受信回路より得られる両受信信号間の位相差を位相差検出手段で検出し、該位相差とエコーの帰来に要した時間とに基づき被探知物体の深度および自船からの被探知物体までの水平距離を算出表示するサイドルッキングソナーにおいて、予め計測した海底の深度情報を記憶する深度情報記憶手段と；海底のある測定点よりのエコーに対して上記位相差検出手段で検出された位相差 $\phi'$ と、前記と同じ測定点に対して前記深度情報記憶手段より読み出した深度及び、測位装置で得られる前記測定点に対する自船位置の水平距離により求められる、第1および第2の受波器の入力点での位相差 $\phi''$ とから、第1の受波器および受信回路と、第2の受波器および受信回路との位相特性の差異により、両受信系を通過する信号間に生じる位相のずれとして $\phi' - \phi'' = d\phi$ を演算する位相ずれ演算手段と；測定時に前記位相差検出手段で検出される位相差を、前記位相ずれ演算手段で演算された位相のずれ $d\phi$ で補正する補正手段と；を備えたことを特徴とするサイドルッキングソナー。

【請求項2】 鉛直線に対し所定角を形成する直線上の所定距離離れた位置に設けられた一対の第1および第2の受波器を備え、いずれか一方の受波器より、垂直方向に広くて水平方向に狭い送波ビームを形成し、前記ビームのエコーを第1及び第2の受波器で捕捉し、これら第1および第2の受波器にそれぞれ接続される第1および第2の受信回路より得られる両受信信号間の位相差を位相差検出手段で検出し、該位相差とエコーの帰来に要した時間とに基づき被探知物体の深度および自船からの被探知物体までの水平距離を算出表示するサイドルッキングソナーにおいて、当該サイドルッキングソナーの送波ビームと一部重なる多数のペンシル形送波ビームを自船の下方および側方に形成し、エコーの帰来するまでに要する時間と、各ペンシルビームの方向から被探知物体の深度および自船からの被探知物体までの水平距離を算出するスキャニングソナーで計測した前記深度および水平距離を受ける深度情報入力部と；水中のある測定対象よりのエコーに対して上記位相差検出手段で検出された位相差 $\phi'$ と、前記深度情報入力部に入力された、前記同じ測定対象に対する深度および水平距離により求められる、第1および第2の受波器の入力点での位相差 $\phi''$ とから、第1の受波器および受信回路と、第2の受波器および受信回路との位相特性の差異により、両受信系を通過する信号間に生じる位相のずれとして $\phi' - \phi'' = d\phi$ を演算する位相ずれ演算手段と；測定時に前記位相差

2

検出手段で検出される位相差を、前記位相ずれ演算手段で演算された位相のずれ $d\phi$ で補正する補正手段と；を備えたことを特徴とするサイドルッキングソナー。

## 【発明の詳細な説明】

【0001】

【産業上の利用分野】本発明は、自船の側方に対し広範囲に水中を探知するサイドルッキングソナーに関する。

【0002】

【従来の技術】サイドルッキングソナーは、図1に示すように、自船の両舷に装備した送受波器から左右に拡がる扇状の超音波ビーム(例えば扇形角 $60^\circ$ 、航行方向の拡がり角 $1.6^\circ$ )を送波し、そのエコーを同送受波器にて検出することにより、海底の起伏、底質変化、魚群等を検出レベルに応じて濃淡あるいは色別表示するものである。

【0003】図2は送受波器の取り付け例を示しており、両舷にそれぞれ二つの受波器 $R_1, R_2$ を備え、一方の受波器 $R_2$ は送波兼用としている。以下に、これらの送受波器を用いた水中物体の深度および水平距離の測定法を図3を用いて説明する。

【0004】 $R_1$ および $R_2$ は右舷側の受波器であり、Sを水中物体とする。両受波器 $R_1, R_2$ 間の距離をD、鉛直方向に対して両受波器 $R_1, R_2$ を結ぶラインのなす角度を $\alpha$ 、両受波器 $R_1, R_2$ の midpoint Oと水中物体Sとを結ぶ線分OSの長さをr、midpoint Oに対する水中物体Sの水平および深度をh、d、両受波器 $R_1, R_2$ を結ぶラインに垂直な方向と線分OSのなす角度を $\theta$ とする。

【0005】線分 $R_1 - S$ と線分 $R_2 - S$ との長さの差を $\Delta Y$ とすると、

$$\Delta Y = 2 \cdot (D/2) \cdot \sin \theta \quad (1)$$

とみなせ、用いた音波の波長を $\lambda$ とすると $\Delta Y$ における位相差 $\phi$ は、

$$\phi = 360^\circ \cdot \Delta Y / \lambda \\ = 360^\circ \cdot D \cdot \sin \theta / \lambda \quad (2)$$

となる。(2)式より、

$$\theta = \sin^{-1} \{ \phi \cdot \lambda / (360^\circ \cdot D) \} \quad (3)$$

midpoint Oからみた水中物体Sの方向を $\theta h$ とすると、

$$\theta h = \alpha + \theta \quad (4)$$

が得られる。

【0006】水中音速をc、線分OSを音波が往復する時間をtとすると直線距離rは、

$$r = t \cdot c / 2 \quad (5)$$

従って、

$$d = r \cdot \sin \theta h \quad (6)$$

$$h = r \cdot \cos \theta h \quad (7)$$

が得られる。尚、tは、O-Sを往復する時間であるが、 $R_2 - S \approx O - S$ とみなせるので線分 $R_2 - S$ を往復する時間とした。

【0007】このように、受波器 $R_2$ で送波したビームに伴う同一水中物体よりのエコーを二つの受波器 $R_1, R$

3

にて受波し、このときの受波信号の位相差、つまり距離差を測定することにより、二つの受波器に対する水中物体の方向が求まる。一方、水中物体Sまでの直線距離rは、音波の要した往復時間より求まるので(6)および(7)式から水中物体の深度dおよび自船直下からの水平距離hが決定される。

【0008】

【発明が解決しようとする課題】上記の従来の測定装置では、各舷毎に受波器およびこれらに接続される受信回路の2組の受信系が設けられているため、上記位相差を正確に求めるためには、2組の受信系の間で位相特性が同じになるように、つまり両受信系で生じる位相遅れが等しくなるように調整する必要があるが、経年変化や温度変化等により、受波器および受信回路で位相特性に差が生じ、測定した前記位相差にこのような位相特性の差異による位相のずれが含まれると、水中物体の正確な位置を測定できなくなるといった課題があった。本発明は、上述した課題を解決するためになされたものであり、2組の受信系間で生じる位相のずれを補正することにより、水中物体の位置を正確に測定できるサイドルッキングソナーを提供することを目的とする。

【0009】

【課題を解決するための手段】第1発明のサイドルッキングソナーは、鉛直線に対し所定角を形成する直線上の所定距離離れた位置に設けられた一対の第1および第2の受波器を備え、いずれか一方の受波器より、垂直方向に広くて水平方向に狭い送波ビームを形成し、前記ビームのエコーを第1及び第2の受波器で捕捉し、これら第1および第2の受波器にそれぞれ接続される第1および第2の受信回路より得られる両受信信号間の位相差を位相差検出手段で検出し、該位相差とエコーの帰来に要した時間とに基づき被探知物体の深度および自船からの被探知物体までの水平距離を算出表示するサイドルッキングソナーにおいて、予め計測した海底の深度情報を記憶する深度情報記憶手段と；海底のある測定点よりのエコーに対して上記位相差検出手段で検出された位相差 $\phi'$ と、前記と同じ測定点に対して前記深度情報記憶手段より読み出した深度及び、測位装置で得られる前記測定点に対する自船位置の水平距離により求められる、第1および第2の受波器の入力点での位相差 $\phi$ とから、第1の受波器および受信回路と、第2の受波器および受信回路との位相特性の差異により、両受信系を通過する信号間に生じる位相のずれとして $\phi' - \phi = d\phi$ を演算する位相ずれ演算手段と；測定時に前記位相差検出手段で検出される位相差を、前記位相ずれ演算手段で演算された位相のずれ $d\phi$ で補正する補正手段と；を備えたことを特徴とする。

【0010】第2発明のサイドルッキングソナーは、鉛直線に対し所定角を形成する直線上の所定距離離れた位置に設けられた一対の第1および第2の受波器を備え、

4

いずれか一方の受波器より、垂直方向に広くて水平方向に狭い送波ビームを形成し、前記ビームのエコーを第1及び第2の受波器で捕捉し、これら第1および第2の受波器にそれぞれ接続される第1および第2の受信回路より得られる両受信信号間の位相差を位相差検出手段で検出し、該位相差とエコーの帰来に要した時間とに基づき被探知物体の深度および自船からの被探知物体までの水平距離を算出表示するサイドルッキングソナーにおいて、当該サイドルッキングソナーの送受波ビームと一部重なる多数のペンシル形送受波ビームを自船の下方および側方に形成し、エコーの帰来するまでに要する時間と、各ペンシルビームの方向から被探知物体の深度および自船からの被探知物体までの水平距離を算出するスキャニングソナーで計測した前記深度および水平距離を受ける深度情報入力部と；水中のある測定対象よりのエコーに対して上記位相差検出手段で検出された位相差 $\phi'$ と、前記深度情報入力部に入力された、前記同じ測定対象に対する深度および水平距離により求められる、第1および第2の受波器の入力点での位相差 $\phi$ とから、第1の受波器および受信回路と、第2の受波器および受信回路との位相特性の差異により、両受信系を通過する信号間に生じる位相のずれとして $\phi' - \phi = d\phi$ を演算する位相ずれ演算手段と；測定時に前記位相差検出手段で検出される位相差を、前記位相ずれ演算手段で演算された位相のずれ $d\phi$ で補正する補正手段と；を備えたことを特徴とする。

【0011】

【作用】図4において、ある海底点からのエコーが受波器 $R_1$ および $R_2$ に入射するときの位相差が $\phi$ であっても、受波器 $R_1$ および受信回路 $S_1$ で生じる位相遅れを $d\phi_1$ 、受波器 $R_2$ および受信回路 $S_2$ で生じる位相遅れを $d\phi_2$ とすると、位相差検出回路Tより出力される位相差 $\phi'$ は、

$$\phi' = \phi + (d\phi_1 - d\phi_2) \quad (8)$$

となる。 $d\phi_1 - d\phi_2 = d\phi$ が二つの受信系間で生じる位相のずれである。

【0012】一方、等深線図などから各海底点に対する深度を記憶させた深度情報記憶手段から読み出し、この深度と、前記測定点に対して測位装置の出力する自船位置を用いて演算した自船からの水平距離とに基づき、第1および第2の受波器の入力点での位相差 $\phi$ が演算により求められる。深度情報記憶手段から読み出した深度が正確でかつ、二つの受信系間で位相のずれがなければ、 $\phi' = \phi$ となるが実際には二つの受信系間で位相のずれ $d\phi$ があり、この位相のずれ $d\phi$ は、次式で求まる。

$$\phi' - \phi = d\phi \quad (9)$$

【0013】このようにして位相差のずれ $d\phi$ がわかれば、測定時に位相差検出手段で検出された位相差 $\phi'$ に対して、補正手段により位相差のずれ $d\phi$ で補正す

5

ば、前記位相差 $\phi'$ に含まれていた位相差のずれ $d\phi$ が除去される。

【0014】第2発明は、上記の予め計測した海底の深度情報に代えて、スキャニングソナーによる正確な深度情報を用いるものであり、ここでサイドルッキングソナーとスキャニングソナーとの相異点について説明する。サイドルッキングソナーは図5に示すように、船底から船首方向には狭い角度( $\phi_L$ )で左舷および右舷方向にはそれぞれ広い角度( $\theta_L$ )の送受波ビーム100を形成することにより、X、Yで示す領域が探査される。このソナーは、航行方向の分解能が優れており、これにより海底を探査すれば水中俯瞰図ともいべきものが得られ、例えば朝日に照らされた山々を飛行機から眺めているかのごとく、遠方まで海底の起伏が陰影をもって細かに表示されるので海底質を的確に知ることができる。しかし、このソナーでは、上述した両受波系統における位相差が原因で探知物体に対する深度および水平距離が不正確であるという欠点がある。

【0015】一方、スキャニングソナーでは図6に示すように、船底より、船首方向に狭く(例えば $1.6^\circ$ )、両舷側方向に扇状に広い( $90^\circ$ )送波ビーム101を形成し、一方、この送波ビーム101と直交するように、船首方向に広く( $20^\circ$ )、側方向に狭い( $2^\circ$ )受波ビーム102を形成し、かつこの受波ビーム102を側方向に走査することにより、送波ビーム101による領域Zが順に探査される。船の真下付近での探知物体の深度および水平距離を正確に検出できるという利点があるが、俯角が小さくなる側方遠方で分解能が悪くなり、そのため海底の細かな起伏がわからず、深度および水平距離も不正確になるという欠点がある。

【0016】このようにスキャニングソナーにおいては船の直下方向で高い分解能が得られるので、この直下方向の正確な探査結果をもってサイドルッキングソナーにおける両送受波系統の位相差を補正しようとしたものであり、その具体的な構成については実施例にて説明することとする。

【0017】

【実施例】図7は、本発明のサイドルッキングソナーの一実施例を示す制御ブロック図であり、この図7では、右舷側の2つの受波器 $R_1$ 、 $R_2$ の受信系における位相差を40 検出する部分のみを示しており、左舷側も同じ構成となる。 $R_1$ および $R_2$ は既述の受波器であり、いずれも1個の超音波振動子で構成され、一方の受波器 $R_2$ は送波兼用としている。3は、トリガパルスが発生するトリガパルス発生器であり、4は、トリガパルス発生器3よりのトリガパルスにより受波器 $R_2$ に送信電力を供給する送信増幅器である。5および6は、受波器 $R_1$ および $R_2$ で検出されたそれぞれ1個の受波信号を増幅する受信増幅器である。7及び8は受信増幅器5および6よりの出力信号が零点を負から正に横切る時点を検出してパルス50

6

を出力するゼロクロス立上り検出器である。9は、クロックパルスが発生するクロックパルス回路であり、10は、カウンタであり、ゼロクロス立上り検出器8よりのパルスがリセット信号として入力されると、クロックパルス回路9よりのクロックパルスを0からカウントする。11は、ラッチ回路であり、ゼロクロス立上り検出器7よりのパルスがセット信号として入力されたとき、カウンタ10におけるカウント値をラッチし、その値は、加算器12とメモリ13とに送出される。

10 【0018】14は、クロックパルス回路であり、15は、カウンタであり、前記トリガパルス発生器3より出力されるトリガパルスがリセット信号として入力されたときにクロックパルス14よりのクロックパルスを0からカウントする。そのカウント値は、切替器16に供給されると共に、 $R_{max}$ 値と比較する比較器17に入力され、この比較器17の出力信号は、切替器16の切替信号として送出されるとともにパルス発生器18に入力される。

【0019】21は、CPUであり、ROM27に格納された制御プログラムに従って後で述べるような演算を行う。22は入力装置であり、自船の位置を検出する高精度測位装置23、方位を検出する方位測定装置24およびキーボード25よりの信号が入力されるとともに、前記トリガパルス発生器3よりのトリガパルスおよびパルス発生器18より出力されるメモリ完了パルスが入力される。26は、CPU21での演算に必要な各種データを随時記憶するRAMである。28は、深度情報記憶手段である等深線ROMであり、各等深線毎の位置を緯度経度で表したものをROM化したものであり、位置をアクセスすることによりその地点の海底深度が得られる。29は出力装置であり、CPU21で求められた $-d\phi$ の値を前記加算器12に送出する。

【0020】上記構成の制御回路の動作を説明する。図8に示す時点 $T_0$ 、 $T_2$ 、 $T_4$ は受波器 $R_2$ の送信タイミングを示しており、時点 $T_0$ にて送信のためにトリガパルス発生器3よりトリガパルスが出力されると、カウンタ15は“0”にリセットされクロックパルス回路14よりのクロックパルスがカウントされると共に、送信増幅器4より送信信号が出力され、受波器 $R_2$ より図1に示したような右舷側に扇状に拡がる超音波のビームが送波される。この超音波ビームの送波により、最初に自船直下の海底面よりのエコーが受波器 $R_2$ で検出され、次にわずかな時間差をおいて受波器 $R_1$ で検出され、受信増幅器6、5より図9に示すような信号が出力される。受信増幅器6の出力信号に対して、ゼロクロス立上り検出器8により零レベルを負から正に横切ったときの時点 $t_1$ が検出されてパルスが出力される。このパルスがリセット信号としてカウンタ10に供給されることにより、カウンタ10はクリアされクロックパルス回路9より出力されるクロックパルスがカウントされ、そのカウント値が逐次にラッチ回路11に入力される。

7

8

【0021】一方、受信増幅器5の出力信号に対しては、ゼロクロス立上り検出器7により零レベルを負から正に横切ったときの時点 $t_2$ が検出されてパルスが出力され、このパルスがセット信号としてラッチ回路11に供給されると、このラッチ回路11は、入力されていたカウント値をラッチする。従ってラッチ回路11は、時点 $t_1$ から時点 $t_2$ までの間のクロックパルスの数をラッチすることになる。このパルス数は、二つの受波器 $R_1$ 、 $R_2$ の取り付け位置と水平物体の方向に起因する時間差であり、クロックパルス回路9のパルスの周期を、用いた音波の周期の $1/360$ にすれば、この時間差は上記の位相差 $\phi'$ で表され、この値 $\phi'$ は加算器12およびメモリ13に入力される。続く時点 $t_3$ から $t_4$ 間においても同様にして位相差 $\phi'$ が求められ、このようにして時間が経過するにつれて自船直下より右方に次第に遠ざかる海底面よりのエコーが次々に検出されてそれらの位相差 $\phi'$ がメモリ13に送出される。

【0022】一方、カウンタ15のカウント値が切替器16を介してメモリ13にアドレスとして送出されており、かつ、この切替器16を介してライト信号が印加されているので、メモリ13に入力される位相差 $\phi'$ は所定のアドレスに次々に格納される。又、時点 $T_0$ 以降においてはCPU21にて図10のフローチャートに示した動作が並行して行われる。

【0023】即ち、トリガパルス発生器3よりのトリガパルスが入力装置22を介してCPU21に入力されると、ステップS1からステップS2へと進み、高精度測位装置23および方位測定装置24よりの自船の測位置および航行の方位を読み込み、この値と予めキーボード25により入力されている探査範囲(本実施例では両舷側方向に1000m)をもとにして、図11に示す等深線図において右舷側の探査範囲での等深線との交点A、B、C、D、Eを求める。次のステップS3で前記の各交点までの水平距離 $h$ を求め、この $h$ と、このときの深度 $d$ (等深線の値)とを(6)式及び(7)式に入力することにより、受波器 $R_1$ と $R_2$ の中心から各交点下の海面までの距離 $r$ を求め、又、そのときの位相差 $\phi''$ を(2)式から求める。ステップS4では、カウンタ15のカウント値が $R_{max}$ となり、パルス発生回路18からメモリ完了パルスが出力される時点 $T_1$ になるのを待つ。尚、ステップS2およびステップS3の処理時間は短く、メモリ完了パルスが出力される時点 $T_1$ で既に終了している。

【0024】さて、時点 $T_1$ になり、比較器17から切替器16に対して切替信号が送出され、切替器16の接点が右方に切り替わることにより、CPU21は、ステップS5において、この切替器16を介してメモリ13に、リード信号を送出し、更に距離 $r$ における測定位相差 $\phi'$ を読み出すべく、所定のアドレス信号 $R$ をメモリ13に送出することにより、メモリ13に記憶されていた交点AないしEに対する位相差 $\phi'$ を順次読み出す。

ここで $r=R \times \Delta r$ である。 $\Delta r$ はカウンタ15の入力クロックパルス周期 $t_p$ とすると、 $\Delta r=c \cdot t_p/2$ となる。以上の説明でわかるように、時点 $T_0$ ないし $T_1$ の間がエコー取り込み期間であり、従って、この期間で所望の範囲よりのエコーが検出されるよう、比較器17に対する $R_{max}$ の設定値が決められる。なお、比較器17はカウンタ15のカウント値が0になった時、切替器16を左方へ切り替える。

【0025】図12は、各交点AないしEに対する、実測の位相差 $\phi'$ (●記号で示す)と等深線図より求めた位相差 $\phi''$ (記号で示す)とを示したものであり、ステップS6では、これらの各交点で対応する兩位相差の引き算、 $\phi' - \phi''$ を行い、それらの平均値を上記の位相差のずれ $d\phi$ とする。このステップS5およびステップS6の処理時間は短く、次にトリガパルスが出力される時点 $T_2$ には終了している。

【0026】この位相差のずれ $-d\phi$ が出力装置29を介して加算器12に送出されることにより、この加算器12において、 $\phi' - d\phi$ の演算が行われ、両受波器 $R_1$ 、 $R_2$ の入射時の位相差 $\phi$ が出力される。尚、ここで補正される位相差 $\phi'$ は前回の送信で得た $-d\phi$ で補正されることになるが、送信間隔程度の短い時間では $d\phi$ の値は変化しないので差し支えない。もし、今回の送信に基づく $d\phi$ で今回の位相差 $\phi'$ を補正するには、メモリ13を2個使用して、今回の送信時に片方のメモリに今回の位相差 $\phi'$ を記憶させると共に今回の位相差 $\phi'$ をカウンタ15の値に従って読み出し、 $d\phi$ で補正すればよい。

【0027】第2発明になるサイドルッキングソナーの一実施例を図13および図14に示している。図13においては図7と異なる箇所について述べる。31は、後で述べるスキヤニングソナーにおける受波ビーム数 $M$ と同値とした $M$ 進のHカウンタであり、トリガパルス発生器3より出力されるトリガがリセット信号として入力されたときクロックパルス14よりのクロックパルスを0からカウントする。そのカウント値は、図14の切替器46に供給され、又、図14の切換器43の切換信号として送出され、更にそのカウント値が $(M-1)$ から0になる時の桁上げパルスがRカウンタ15に送出される。Rカウンタ15はN進カウンタであり、トリガパルス発生器3より出力されるトリガがリセット信号として入力されたとき、Hカウンタ31よりの桁上げパルスを0からカウントする。そのカウント値は、切換器16および図14の切換器46に供給されると共に、 $R_{max}$ ( $R_{max} < N$ )値と比較する比較器17に入力される。この比較器17の出力は、パルス発生器18と、切換器16および図14の切換器46の各々の切換信号として送出される。入力装置22にはパルス発生器18より出力されるメモリ完了パルスが入力される。

【0028】図14は、図13のサイドルッキングソナ

一に付加されるスキヤニングソナー部の一実施例を示している。R<sub>3</sub>およびTXは、受波器および送波器であり、図15の展開図に示されるように、受波器R<sub>3</sub>は、航行方向と直角の方向にj個の超音波振動子が配列されており、送波器TXは、航行方向にk個の超音波振動子が配列されている。右側にあるR<sub>1</sub>、R<sub>2</sub>は、図13における受波器であり、左側のR<sub>1</sub>'、R<sub>2</sub>'は左舷側の受波器である。

【0029】40は、送信増幅器であり、41は、受波器R<sub>3</sub>のj個の超音波振動子よりの受波信号をそれぞれ増幅する受信増幅器である。42は、位相合成回路であり、j系統の各受波信号を公知の技法で位相合成することにより、図6で示されるように、側方向に順に走査されるM個の受波ビームを形成する。切換器43は、位相合成回路42により形成されたM個の受波ビームを順に取り出し、A/D変換器44にてデジタル化した後にメモリ45に供給する。

【0030】上記構成の制御回路の動作を再び図8および図9を用いて説明する。図8に示す時点T<sub>0</sub>、T<sub>2</sub>、T<sub>4</sub>は受波器R<sub>2</sub>および送波器TXの送信タイミングを示しており、時点T<sub>0</sub>にて送信のためにトリガパルス発生器3よりトリガパルスが出力されると、Rカウンタ15およびHカウンタ31は“0”にリセットされると共に、送信増幅器4、40より予め定められたパワー、パルス幅および周波数の送信信号が出力され、受波器R<sub>2</sub>により図5に示したように右舷側に扇状に拡がる送波ビーム100が形成され、又、送波器TXにより、図6に示したように両舷方向に拡がる送波ビーム101が形成される。そして、海底から反射された探知信号は受波器R<sub>1</sub>、R<sub>2</sub>、R<sub>3</sub>で受波され、受信増幅器5、6、41にて増幅される。

【0031】図13のサイドルッキングソナーにおいては、超音波ビームの送波により、最初に自船直下の海底面よりのエコーが受波器R<sub>2</sub>で検出され、次にわずかな時間差を置いて受波器R<sub>1</sub>で検出され、受信増幅器6、5より図9に示すような信号が出力される。受信増幅器6の出力信号に対して、ゼロクロス立上り検出器8により零レベルを負から正に横切ったときの時点t<sub>1</sub>が検出されてパルスが出力される。このパルスがリセット信号としてカウンタ10に供給されることにより、カウンタ10はクリアされクロックパルス回路9より出力されるクロックパルスがカウントされ、そのカウント値が逐次にラッチ回路11に入力される。

【0032】受信増幅器5の出力信号に対しては、ゼロクロス立上り検出器7により零レベルを負から正に横切ったときの時点t<sub>2</sub>が検出されてパルスが出力され、このパルスがセット信号としてラッチ回路11に供給されると、このラッチ回路11は、入力されていたカウント値をラッチする。従ってラッチ回路11は、時点t<sub>1</sub>から時点t<sub>2</sub>までの間のクロックパルスの数をラッチする

ことになる。このパルス数は、二つの受波器R<sub>1</sub>、R<sub>2</sub>の取り付け位置と水平物体の方向に起因する時間差であり、クロックパルス回路9のパルスの周期を、用いた音波の周期の1/360にすれば、この時間差は上記の位相差φ'で表され、この値φ'は加算器12およびメモリ13に入力される。続く時点t<sub>3</sub>からt<sub>4</sub>間においても同様にして位相差φ'が求められ、このようにして時間が経過するにつれて自船直下より右方に次第に遠ざかる海底面よりのエコーが次々に検出されてそれらの位相差φ'がメモリ13に送出される。

【0033】一方、図14のスキヤニングソナーにおいては、送波器TXによる送波により、海底面よりのエコーが受波器R<sub>3</sub>で受波される。このj個の受波信号は、位相合成回路42により位相合成され、走査角の異なるM個の受波ビームが形成される。Hカウンタ31よりの切換信号により切換器43が制御されることにより、M個の受波ビームの中からHカウンタ31のカウント値が示す方向の受波ビームが選択され、A/D変換器44を介してメモリ45に格納される。

【0034】ここでスキヤニングソナーにおける動作を図17を用いて更に詳しく述べる。θ<sub>sm</sub>は、m番目のビームの直下方向dよりの角度(右舷側を+)を示し、θ<sub>sm</sub> = Δθ<sub>s</sub> { (M-1) / 2 - m }、ここでMは奇数であり、(M-1) / 2番目のビームは直下方向である。R<sub>m</sub>は、m番目のビーム内に存在していた海底のメモリ45におけるR方向の位置を示す。r<sub>m</sub>は、m番目のビーム内に存在していた海底の自船からの直線距離(単位m)を示し、r<sub>m</sub> = Δr × R<sub>m</sub>である。h<sub>m</sub>、d<sub>m</sub>は、m番目のビーム内に存在していた海底の自船からの水平距離と進度である。h<sub>m</sub>は右舷側を+、d<sub>m</sub>は下方を+としており、いずれも単位はメートルである。

h<sub>m</sub> = r<sub>m</sub> × sin θ<sub>sm</sub>、d<sub>m</sub> = r<sub>m</sub> × cos θ<sub>sm</sub>  
の関係がある。又、Δrはメモリ13およびメモリ45にデータを取り込むr方向(距離方向)の間隔でHカウンタ31の出力する桁上げパルスの周期をt<sub>p</sub>とすると、Δr = c · t<sub>p</sub> / 2となる。

【0035】図13、図14に戻り、メモリ13およびメモリ45には、それぞれサイドルッキングソナーの位相差とスキヤニングソナーの探知信号がΔr (m)ごとにr<sub>max</sub>まで1送信分記憶される。r<sub>max</sub>は、本発明装置が使用される海域において図5におけるビーム端でも海底に到達するのに十分な船からの直線距離である。ここでr<sub>max</sub> = R<sub>max</sub> × Δrである。ラッチ回路11およびA/D変換器44の出力ビット数をβ<sub>1</sub>、β<sub>2</sub>とすると、メモリ13、45の記憶容量は、それぞれβ<sub>1</sub> × R<sub>max</sub>、β<sub>2</sub> × R<sub>max</sub> × Mとなる。

【0036】Rカウンタ15のカウント値がR<sub>max</sub>になるまでのT<sub>0</sub>ないしT<sub>1</sub>間は切換器16、46は図示したように左方に切り替わっており、従って、Rカウンタ15のカウント値は切換器16を介してメモリ13にアド

レスとして送出され、かつ、この切換器16を介してライト信号が印加されているので、メモリ13に入力される位相差 $\phi'$ は所定のRアドレスに次々に格納される。

【0037】一方、Hカウンタ31およびRカウンタ15のカウンタ値が切換器46を介してメモリ38に送出されており、かつ、この切換器46を介してライト信号が印加されているので、メモリ45に入力される探知信号は所定のRとHで決まるアドレスに次々に格納される。

【0038】さて、時点 $T_1$ になり、メモリ13、45への信号の書込みが終了すると、比較器17から切替器16、46に対して切替信号が送出され、切替器16、34の接点が右方に切り替わると同時に、パルス発生器18よりのメモリ完了パルスが入力装置22を介してCPU21に入力されると、CPU21は、図16のステップS11からステップS12へと進み、切換器46を介してメモリ45にリード信号を送出し、スキャニングソナーのm番目のビームで受信した $r=0$ ないし $r_{max}$ までの探知信号を読み出すべく、所定のアドレス信号をメモリ45に送出する。つまりHアドレスはmとし、Rアドレスを0から順に $R_{max}-1$ とする。

【0039】次に読み出した $R_{max}$ 個の探知信号中、例えば最大の探知信号が存在している位置すなわちRアドレス値 $R_m$ を海底位置とする。そして $R_m$ 、 $\theta_{sm}$ より $r_m$ 、 $d_m$ 、 $h_m$ を求め、その時の位相差 $\phi''$ を(2)、(4)、(6)、(7)式から求める。なお、図17と図3の0点は一致しているものとみなす。

【0040】次にCPU21は、ステップS13において、切替器16を介してメモリ13に、リード信号を送出し、 $R_m$ のアドレス信号をメモリ13に送出することにより、メモリ13に記憶されていた $r_m$ に対する位相差 $\phi'$ を読み出す。これをスキャニングソナーの右半分のビームに対して、即ち $m=0$ から $(M-1)/2$ まで繰り返す。

【0041】以上の説明でわかるように、時点 $T_0$ ないし $T_1$ の間がエコー取り込み期間であり、従って、この期間で所望の範囲よりのエコーが検出されるよう、比較器17に対する $R_{max}$ の設定値が決められる。

【0042】図18は、スキャニングソナーによる実測の位相差 $\phi''$ (●記号で示す)と同じ距離上のサイドルッキングソナーにより求めた位相差 $\phi'$ (記号で示す)とを示したものであり、ステップS4では、これらの各点で両位相差の引き算、 $\phi' - \phi''$ を行い、それらの平均値を上記の位相差のずれ $d\phi$ とする。このステップS11およびステップS14の処理時間は短く、次にトリガパルスが出力される時点 $T_2$ には終了している。

【0043】この位相差のずれ $d\phi$ が出力装置29を介して加算器12に送出されることにより、この加算器12において、 $\phi' - d\phi$ の演算が行われ、両受波器 $R_1$ 、 $R_2$ の入射時の位相差 $\phi$ が出力される。尚、ここで

補正される位相差 $\phi'$ は前回の送信で得た $-d\phi$ で補正されることになるが、送信間隔程度の短い時間では $d\phi$ の値は変化しないので差し支えない。もし、今回の送信に基づく $d\phi$ で今回の位相差 $\phi'$ を補正するには、メモリ13を2個使用して、次の送信時に片方のメモリに次の位相差 $\phi'$ を記憶させると共に今回の位相差 $\phi'$ をRカウンタ15の値に従って読み出し、 $d\phi$ で補正すればよい。上記の実施例においては、送波器TXと受波器 $R_2$ から送波される超音波パルスの周波数は互いに干渉しないよう異なるものでなければならぬが、送波器TXと受波器 $R_3$ は同じ周波数のものであり、受波器 $R_1$ と $R_2$ とは同じものである。又、受波器 $R_1$ 、 $R_2$ 、 $R_3$ をすべて同じ周波数のものにして送波器TXを省略することもできる。

【0044】

【発明の効果】以上説明したように、本第1発明では、予め正確に測定されたある測定点に対し、計算により、2つの受波器の入力点での位相差 $\phi''$ を求めておき、そして同じ測定点に対して2つの受波器により位相差 $\phi'$ を測定し、 $\phi' - \phi'' = d\phi$ を2つの受信系間での位相のずれとして、これ以降に実際に測定した位相差をこの位相のずれ $d\phi$ で補正するようにしたので、2組の受信系間で生じる位相差のずれを除去することができ、よって水中物体の位置を正確に測定できる。第2発明は、上記の予め計測した海底の深度情報に代えて、スキャニングソナーによる正確な深度情報を用いるものであり、この装置によればリアルタイムで正確な水中探知を行える。

【図面の簡単な説明】

【図1】 サイドルッキングソナーで形成されるビームを示す斜視図

【図2】 サイドルッキングソナーにおける送受波器の取付け例を示す図

【図3】 サイドルッキングソナーの動作原理を説明するために用いた図

【図4】 本発明の原理を説明するために用いた図

【図5】 サイドルッキングソナーにおける送受波ビームを示す図

【図6】 スキャニングソナーにおける送受波ビームを示す図

【図7】 本第1発明のサイドルッキングソナーの一実施例を示す制御ブロック図

【図8】 図7の制御ブロック図の動作を示すタイムチャート

【図9】 図7の制御ブロック図の動作を示すタイムチャート

【図10】 図7の制御ブロック図の動作を示すフローチャート

【図11】 右舷方向の探査範囲内における等深線図との交点を示す図

【図12】 実測により得た位相差と、等深線からのデータに基づき得た位相差とを示すグラフ

【図13】 本第2発明のサイドルッキングソナーの一実施例を示す制御ブロック図

【図14】 図13の装置に付加されるスキヤニングソナー部の一実施例を示すブロック図

【図15】 図13の装置における送受波器の取り付け例を示した展開図

【図16】 図13の装置の動作を示すフローチャート

【図17】 図13の装置において位相差の計算を説明するために用いた図

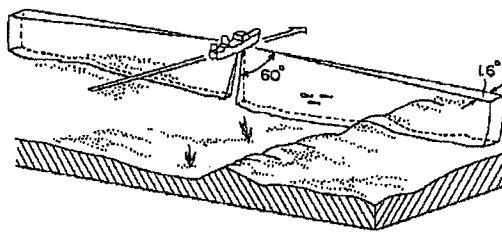
【図18】 スキヤニングソナーにおけるビームの走査を示した図

【符号の説明】

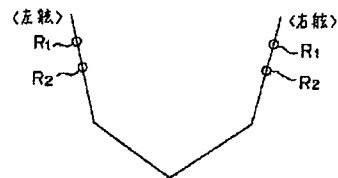
- R 受波器
- 3 トリガパルス発生器
- 4 送信増幅器
- 5 受信増幅器
- 6 受信増幅器
- 7 ゼロクロス立上り検出器
- 8 ゼロクロス立上り検出器
- 9 クロックパルス回路
- 10 カウンタ
- 11 ラッチ回路
- 12 加算器

- 13 メモリ
- 14 クロックパルス回路
- 15 カウンタ
- 16 切替器
- 17 比較器
- 18 パルス発生器
- 21 CPU
- 22 入力装置
- 23 高精度測位装置
- 24 方位測定装置
- 25 キーボード
- 26 RAM
- 27 ROM
- 28 等深線ROM
- 29 出力装置
- 31 カウンタ
- TX 送波器
- 40 送信増幅器
- 41 受信増幅器
- 20 42 位相合成回路
- 43 切換器
- 44 A/D変換器
- 45 メモリ
- 46 切換器

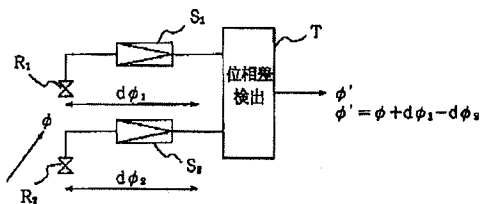
【図1】



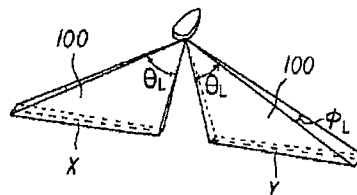
【図2】



【図4】

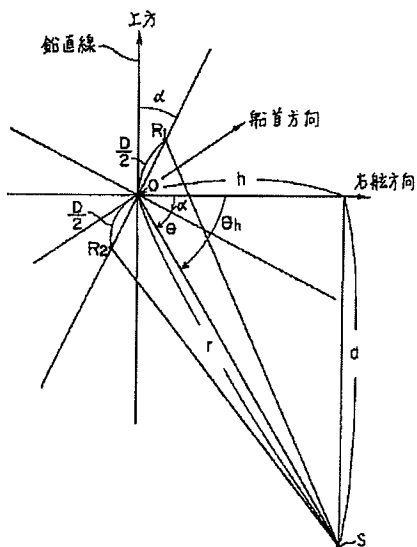


【図5】

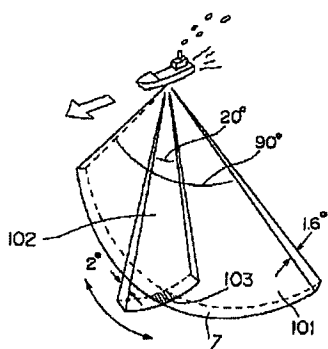




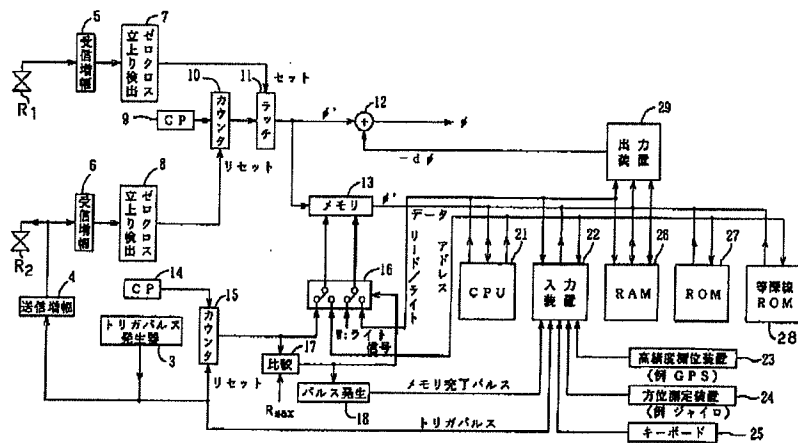
【図3】



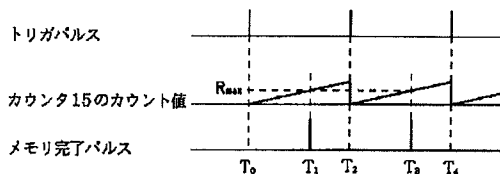
【図6】



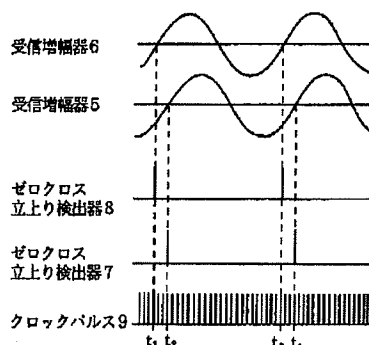
【図7】



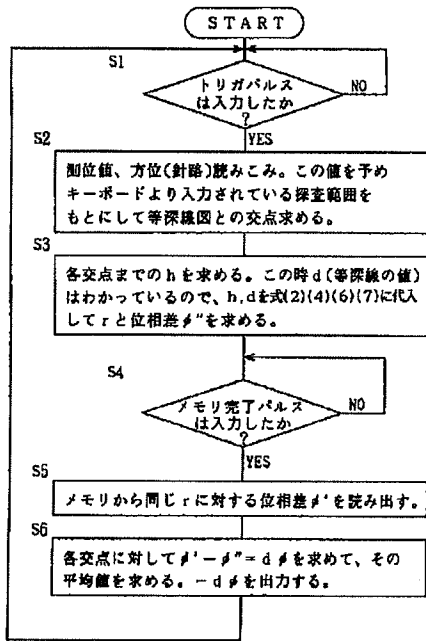
【図8】



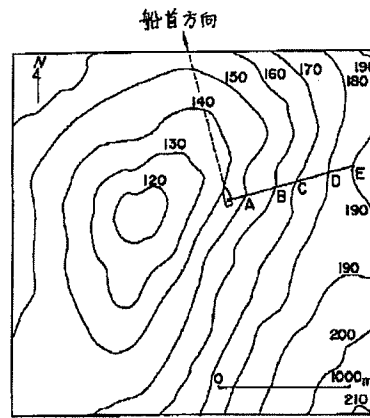
【図9】



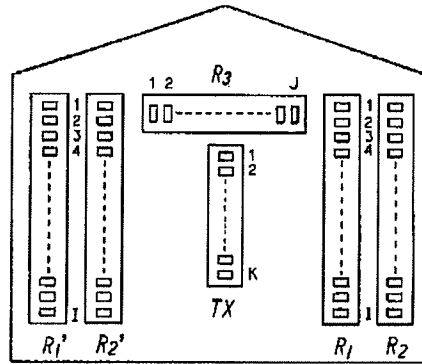
【図10】



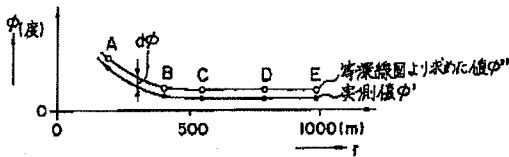
【図11】



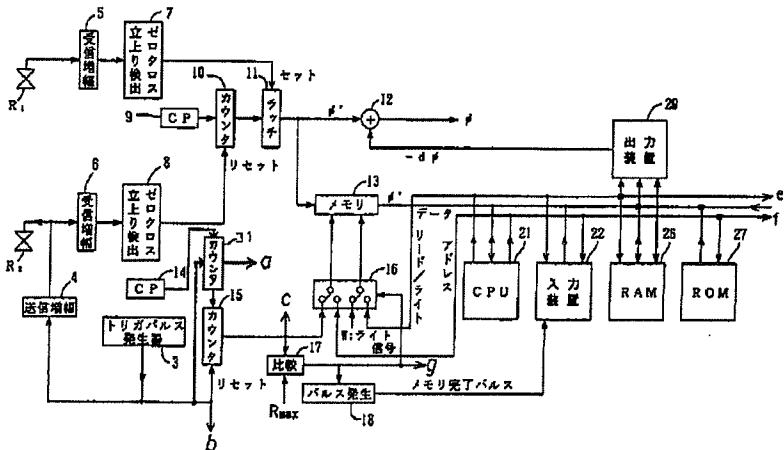
【図15】



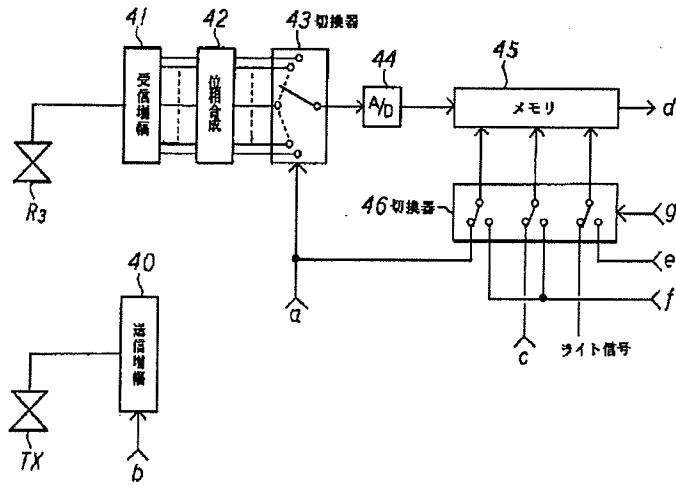
【図12】



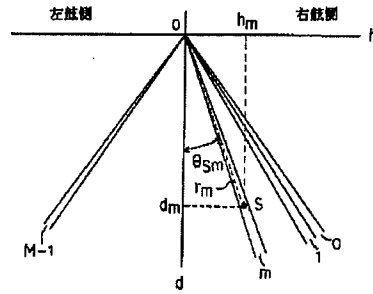
【図13】



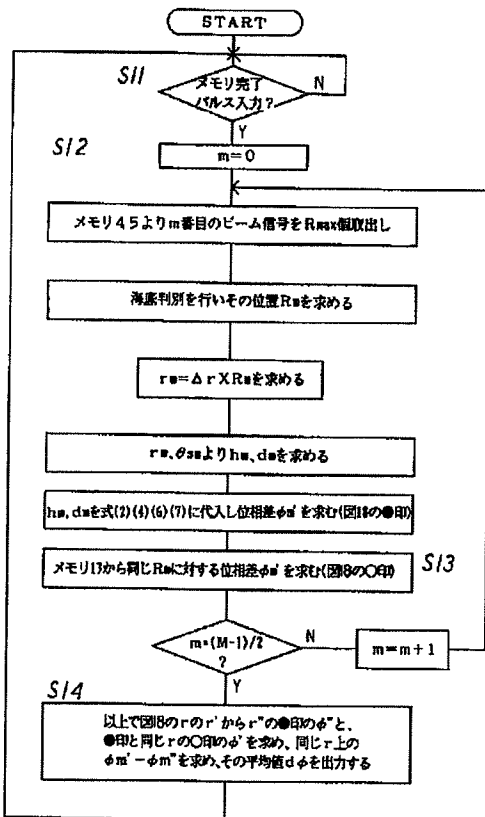
【図14】



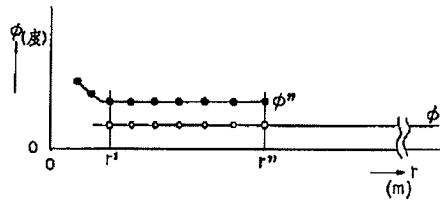
【図17】



【図16】



【図18】

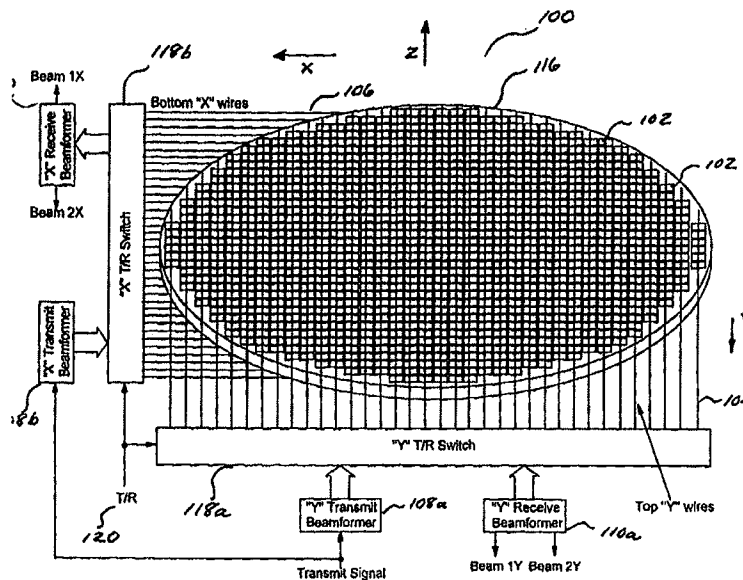




INTERNATIONAL APPLICATION PUBLISHED UNDER THE PATENT COOPERATION TREATY (PCT)

<p>(51) International Patent Classification <sup>6</sup> : <b>G01S 15/60, 15/89</b></p>	<p><b>A1</b></p>	<p>(11) International Publication Number: <b>WO 98/15846</b> (43) International Publication Date: 16 April 1998 (16.04.98)</p>
<p>(21) International Application Number: PCT/US97/18061 (22) International Filing Date: 7 October 1997 (07.10.97) (30) Priority Data: 08/726,644 7 October 1996 (07.10.96) US (71) Applicant: ROWE-DEINES INSTRUMENTS, INCORPORATED [US/US]; 9855 Businesspark Avenue, San Diego, CA 92131 (US). (72) Inventors: YU, Xiaolong; 10631 Calston Way, San Diego, CA 92126 (US). BRADLEY, Steven, E.; 5096 Corte Playa Catalina, San Diego, CA 92124 (US). ROWE, Francis, D.; 5723 Lodi Street, San Diego, CA 92117 (US). (74) Agent: SIMPSON, Andrew, H.; Knobbe, Martens, Olson and Bear, 16th floor, 620 Newport Center Drive, Newport Beach, CA 92660 (US).</p>		<p>(81) Designated States: JP, NO, European patent (AT, BE, CH, DE, DK, ES, FI, FR, GB, GR, IE, IT, LU, MC, NL, PT, SE).  <b>Published</b> <i>With international search report.</i></p>

(54) Title: TWO-DIMENSIONAL ARRAY TRANSDUCER AND BEAMFORMER



(57) Abstract

An acoustic array transducer capable of forming narrow dispersion, broadband or narrowband acoustic beam sets in two dimensions with a minimum aperture size. Concurrent yet independent electrical interfacing with array transducer elements allows simultaneous formation of multiple transmit and receive beams inclined within two planar orientations normal to the array face, while requiring a minimum amount of supporting circuitry. A method of economically and accurately fabricating the aforementioned transducer array by incrementally dicing bonded layers of solid discs of transducer materials being rigidly held together is also disclosed.

**FOR THE PURPOSES OF INFORMATION ONLY**

Codes used to identify States party to the PCT on the front pages of pamphlets publishing international applications under the PCT.

AL	Albania	ES	Spain	LS	Lesotho	SI	Slovenia
AM	Armenia	FI	Finland	LT	Lithuania	SK	Slovakia
AT	Austria	FR	France	LU	Luxembourg	SN	Senegal
AU	Australia	GA	Gabon	LV	Latvia	SZ	Swaziland
AZ	Azerbaijan	GB	United Kingdom	MC	Monaco	TD	Chad
BA	Bosnia and Herzegovina	GE	Georgia	MD	Republic of Moldova	TG	Togo
BB	Barbados	GH	Ghana	MG	Madagascar	TJ	Tajikistan
BE	Belgium	GN	Guinea	MK	The former Yugoslav	TM	Turkmenistan
BF	Burkina Faso	GR	Greece		Republic of Macedonia	TR	Turkey
BG	Bulgaria	HU	Hungary	ML	Mali	TT	Trinidad and Tobago
BJ	Benin	IE	Ireland	MN	Mongolia	UA	Ukraine
BR	Brazil	IL	Israel	MR	Mauritania	UG	Uganda
BY	Belarus	IS	Iceland	MW	Malawi	US	United States of America
CA	Canada	IT	Italy	MX	Mexico	UZ	Uzbekistan
CF	Central African Republic	JP	Japan	NE	Niger	VN	Viet Nam
CG	Congo	KE	Kenya	NL	Netherlands	YU	Yugoslavia
CH	Switzerland	KG	Kyrgyzstan	NO	Norway	ZW	Zimbabwe
CI	Côte d'Ivoire	KP	Democratic People's	NZ	New Zealand		
CM	Cameroon		Republic of Korea	PL	Poland		
CN	China	KR	Republic of Korea	PT	Portugal		
CU	Cuba	KZ	Kazakstan	RO	Romania		
CZ	Czech Republic	LC	Saint Lucia	RU	Russian Federation		
DE	Germany	LI	Liechtenstein	SD	Sudan		
DK	Denmark	LK	Sri Lanka	SE	Sweden		
EE	Estonia	LR	Liberia	SG	Singapore		

**TWO-DIMENSIONAL ARRAY TRANSDUCER AND BEAMFORMER**Background of the Invention5           **1. Field of the Invention**

The present invention relates to a planar array sonar transducer which simultaneously forms multiple, narrow dispersion acoustic beam sets in two planar dimensions normal to the array face.

10           **2. Description of Related Technology**

Transducers which simultaneously generate multiple narrow acoustic beams inclined outward in two axes from a plane are currently used in different types of acoustic backscatter systems that measure velocity and/or distance in two or three dimensions. Examples include Acoustic Doppler Velocity Sensors (ADVS) which employ a simple set of four beams in a "Janus" configuration for two or three axis velocity measurement, sonars which measure distance to target in the water (such as forward scanning sonars), and bottom mapping sonars.

ADVS's are widely used for measurement of vertical profiles of water current measurements and for earth and/or water referenced velocity measurement for vessel navigation. They measure 3-axis velocities by measuring velocity along lines of position defined by narrow acoustic beams. A minimum of three beams oriented at different directions are required to measure the three orthogonal velocity components. Typically four narrow (1-4°) conical transmit/receive beams are employed positioned in two axes of a plane surface and inclined relative to the normal to that plane. This configuration, well known in the acoustic arts, is referred to as a Janus configuration; the two sets of narrow conical beams are symmetrically inclined outward and positioned at four 90° circumferential increments on the surface of a larger (typically 60°) outward opening cone. Currently available transducer technology used to produce this four beam configuration include assemblies of 4-piston transducers or a pair of one-dimensional phased array transducers (i.e., arrays in which acoustic beams are formed in one plane only).

Conventional 4-piston transducer assemblies consist of four independent circular piston-type transducers, each producing a single narrowly dispersed conical transmit/receive beam directed normal to the piston face. As shown in Fig. 1, the four transducers are physically positioned in a rigid assembly to achieve the required Janus beam configuration. For conventional narrowband ADVS applications, each of these transducers requires an effective transmit and receive bandwidth of approximately 2% of the nominal acoustic carrier frequency. Typical carrier frequencies range from 100 kHz to 5 MHz. Each piston transducer is typically fabricated from either a single solid disc of ceramic material or from a flat array of small ceramic elements. Modern broadband ADVS's operate with fractional bandwidths on the order of 50%. They are also fabricated from solid ceramic discs or flat arrays, but

have one or more additional impedance matching layers bonded to the face to achieve the required bandwidth. U.S. Patent No. 5,343,443, "Broadband Acoustic Transducer", discloses such a system. The primary advantage of this 4-piston method is simplicity of the transducer construction and operation. Each piston transducer is driven by a separate signal, and no beamformer circuitry is required.

5

Single beam transducers such as those previously described may also be beamforming arrays. These arrays generally have all of the transducer elements electrically connected in parallel. Beam angle alignment is achieved primarily by virtue of proper positioning of the piston. Disadvantages associated with such arrays include 1) the requirement for a large, heavy mechanical structure to support the transducers; 2) the shape of its face, whether concave or convex, does not lend itself to a smooth hydrodynamic form unless a thick, acoustically transparent material with a flat face is attached to the front portion of the assembly; 3) a large aperture is required to form the beams; and 4) accurate measurement of velocity requires that the speed of sound at the transducer face be known.

10

15

An improved transducer physical configuration for producing the four Janus configuration beams in 2 axes for ADVS applications is to use a pair of one-dimensional phased array transducers. As shown in Fig. 2, a single one-dimensional planar array produces two conical beams inclined relative to the direction perpendicular to the longitudinal axis of the array (see U.S. Patent No. 4,641,291, "Phased Array Doppler Sonar Transducer"). To produce the four ADVS beams, two adjacently positioned arrays are used, with one rotated 90° relative to the other about the aforementioned perpendicular direction. Since each one-dimensional array utilizes a single aperture, which is only slightly larger than a single beam piston, to produce two beams, a factor of approximately two improvement in aperture spatial efficiency is realized relative to the multiple piston approach.

20

25

One-dimensional phased arrays are typically constructed with parallel line arrays separated by a half wavelength of the carrier frequency. Each line array may be constructed using a number of small square or circular ceramic elements wired in parallel on both faces, or from a singular, elongated rectangular element. Alternate line arrays are wired together electrically in parallel to provide the necessary beamforming functions. One such wiring arrangement involves electrically connecting each fourth line array in parallel. Both circular and rectangular array geometries are used. To produce a beam dispersion of 4° required for a typical ADVS, an aperture of about 16 wavelengths (32 elements spaced at 1/2 wavelengths) in diameter is required. For typical ADVS operating frequencies in the range of 100 kHz to 5 MHz (single piece commercially available line elements normally operate in this region), an array of 32 parallel long elements is preferred over a 32 X 32 diced array (i.e., one which is cut or diced from a single solid element) due to production assembly cost advantages.

30

35

When the array is operating in the "receive" mode (i.e., receiving incoming signals), a simple phase shift beamformer is used to phase shift the signals received by the two arrays (assuming the configuration previously

described) by  $\pm 90^\circ$  to compensate for the time delay produced by acoustic propagation over the half wavelength path length in the medium between alternate line arrays. A phase shift is an approximation to time delay which is valid only for narrow fractional bandwidth signals. For narrowband signals, the summation process forms two receive beams inclined to the flat array plane surface. When operating in the "transmit" mode, the two arrays are driven by narrowband signals with appropriate relative phase shifts to form the four (two per array) simultaneously transmitted beams.

When these phased arrays are driven by wideband signals, the different frequencies contained in the signals are dispersed from the transducers in different angular directions, effectively broadening the beams. The phased array technique forms narrow beams only when signal bandwidths are less than about 3%. This is adequate for narrowband ADVS applications, but falls short of the bandwidth associated with modern broadband ADVS systems by a factor of roughly between 8 and 16 (see, for example, U.S. Patent No. 5,483,499, "Broadband Acoustic Doppler Current Profiler").

An improvement in bandwidth/dispersion performance can be obtained for the pair of one-dimensional phased array transducers previously described by replacing the simple  $90^\circ$  phase shifting beamformer network (in both transmit and receive modes) with a more complex time-delay network. Use of the time delay decouples frequency from the relative angle of incidence of the received/transmitted wave, thereby reducing angular beam spreading in large bandwidth applications. With this time-delay array method, each of the individual line array signals are time delayed and summed together to form a composite signal which is independent of the angle of incidence. The primary drawback associated with this technique is the more complex transmit and receive beamformer.

An added performance benefit of the phased and time-delay array approach is that, for the ADVS application, the velocity components parallel to the array face are inherently self-correcting for changes in the speed of sound through the medium. As the speed of sound varies, differential path lengths and the corresponding time delays associated with various array transducers will vary accordingly. Self-correction results from the fact that the beam angle varies with the speed of sound in such a way as to directly compensate for errors in computing the velocity component parallel to the transducer face (usually horizontal). This minimizes, but does not completely eliminate, the need to measure sound velocity at the transducer face for high accuracy navigation.

Thus, relative to 4-piston assemblies, one-dimensional phased arrays provide improved spatial efficiency for fixed beam characteristics, have a flat face for better hydrodynamic performance, and have improved velocity resolution in media with varying sound propagation velocities, yet do not adequately support broadband ADVS operation. One-dimensional time-delay arrays have the added benefit of supporting broadband ADVS operation as well.



One-dimensional phased and time-delay array techniques are also commonly used for bottom mapping and forward scanning applications to form more than two beams within a single plane of the array face. For these applications, multiple phase and/or time-delay beamformers are coupled to a single one-dimensional array, each beamformer having different phase/time-delays to simultaneously form multiple beams at different angles of inclination relative to the array face, but all within a single planar orientation perpendicular to the array face. If measurement in a second planar orientation is required, two adjacent one-dimensional phase or time-delay arrays are used, with one physically rotated 90° from the other as previously described.

For each of the above mentioned techniques of forming multiple acoustic beams inclined within two planes perpendicular to the array face plane, an aperture of at least twice the size of that required to form any single narrow beam is necessary. It is possible to form two or more conical beams within two planes perpendicular to the array face if the proper signal can be provided to each element of the array. The formation of four beams in two perpendicular planes from a single planar array is depicted in Fig. 3. It is well understood in the art that such planar arrays can form beams centered around arbitrary angles relative to the array face if appropriate phase shifts are introduced between individual transducer elements; this concept has been in use for many years in radar antenna arrays and to a lesser extent in sonar transducer arrays. It is also well understood that beam forming for wide bandwidth applications requires true time delays between elements to compensate for the time delays produced by propagation over different path lengths in the medium associated with different elements.

A substantial reduction in the size, weight, and cost of the ADVS transducer assembly could be achieved if four inclined beams oriented in two planes perpendicular to the array face could be formed from a single planar array of transducer elements, using the full available aperture to form all beams, as shown in Fig. 3. To accomplish this, a 32 x 32 array of about 800 elements is required, with the array elements precisely aligned at 1/2 wavelength increments in both plane face dimensions, i.e., with respect to the X-Y coordinate system of Fig. 2. Assembly of this precision array from 800 individual elements is relatively complex. Complex phase and/or time-delay circuitry is also required to support beamforming in two dimensions for this large number of elements. Using existing array technology, a separate power amplifier and phase and/or time-delay circuit would generally be required for each individual element of the array. These array fabrication and beamformer complexity factors make the use of a two dimensional planar array an economically impractical solution for nearly all applications.

Hence, it would be highly desirable to provide an improved planar array which could produce narrow dispersion beam sets in two dimensions relative to the array face within a substantially reduced aperture, and which would utilize simplified phase and/or time-delay beamforming circuitry to support the large number of individual transducer elements inherent in such arrays. Furthermore, it would be highly desirable to provide an efficient and cost-effective method of fabricating the aforementioned array to make its manufacture and use economically practical.

Summary of the Invention

The present invention satisfies the aforementioned needs by providing an improved system and method of forming a multi-planar narrowband or broadband beam set inclined relative to a transducer array face, with reduced aperture area. A cost effective and simplified method for manufacturing the transducer array is also disclosed.

In a first aspect of the invention, each 2-axis beam set formed from the single 2-axis planar array of transducer elements uses all of the elements in the array and the full available aperture to form each of the beams. From an aperture spatial efficiency viewpoint, this is an optimal approach to forming multiple narrow 2-axis beams, because each beam can be made as narrow as allowed by the available aperture area. The overall aperture area will be minimized for a given beamwidth of each of the multiple 2-axis beams. Relative to the previously described 4-piston approach, the aperture diameter is reduced by a factor of 2.5, (a factor of 6 for the area), the transducer face is substantially more hydrodynamic (thereby reducing flow resistance, noise, and potential inaccuracies resulting from air coalescing near the aperture), and the transducer assembly volume is reduced by a factor of roughly 10. Relative to the previously described dual 1-dimensional array approach, the aperture area is reduced by a factor of two.

In a second aspect of the invention, the multi-planar (2 axis) array disclosed herein utilizes a greatly reduced number of phase or time-delay beamforming circuits relative to the number of elements in the array. The capability to produce multiple narrow beams in two axes from a single planar array is achieved by a method of electrically interfacing independently with the two sides of the array permitting independent and simultaneous formation of multiple inclined transmit and receive beams in two dimensions of the array plane. This is accomplished by electrically connecting together the backside rows and frontside columns of the array, connecting the backside and frontside parallel sets to beamformer networks which have a low electrical impedance (relative to the impedance of the rows and columns) in both the transmit and receive mode of operation, and processing the transmit/receive signals to/from the two array sides to simultaneously and independently form multiple inclined transmit/receive beams in two dimensions of the array plane. The two directions are normally but not necessarily orthogonal to each other.

In another aspect of the invention, a cost effective method of fabricating the planar array of approximately 800 precisely aligned elements is disclosed. While, as previously described, prior art one-dimensional multibeam arrays may be fabricated from an array of on the order of 32 long rectangular transducer elements of about 1/2 wavelength in width, the preferred embodiment of the present invention requires the use of array elements which have dimensions of approximately 1/2 wavelength of carrier frequency in both face dimensions. Furthermore to achieve the necessary bandwidth for broadband applications, each element must be constructed of several layers of different materials which must be bonded together. Hence, an array of roughly 800 multi-layered elements (32 x 32) is required to be precisely assembled in a cost effective manner to make the aforementioned design economically

feasible. To accomplish this, an improved method of fabricating this complex array is disclosed in which several cylindrical discs (each having a diameter equal to that of the final array) are sequentially bonded together and partially sliced with a parallel diamond blade saw at various stages of the process such that at all stages of fabrication, the sliced elements are rigidly held together by a solid layer. When completed, the array is internally  
5 diced into the desired form with the required precision, and held in shape by the combination of a mechanically rigid and acoustically transparent front facing and a solid backing disc.

The aforementioned simplified design and fabrication techniques make it economically practical to produce cost effective commercial products with the form and performance advantages of the 2-dimensional flat array. The present invention provides significantly improved performance for typical ADVS (i.e. a four beam 150 kHz transducer  
10 with 4° one-way beamwidths) applications. These and other objects and features of the present invention will become more fully apparent from the following description and appended claims taken in conjunction with the following drawings.

#### 15 Brief Description of the Drawings

Fig. 1 is a top view of a prior art 4-piston transducer array in Janus configuration.

Fig. 2 is a perspective view of a prior art one-dimensional phased acoustic array, illustrating the formation of two narrow acoustic beams.

20 Fig. 3 is a perspective view illustrating a typical configuration of four acoustic beams inclined relative to the array normal (i.e., Z-axis) and positioned within two planes perpendicular to the array face plane (i.e., X-Y plane).

Fig. 4 a functional block diagram of the preferred embodiment of the two-dimensional transducer array, including the method of electrical array element interconnection, and the method of array-to-beamformer interconnection to the transmit and receive beamformers.

25 Fig. 5 is a functional block diagram illustrating the operation of a simplified sixteen element 2-dimensional phased array transducer operating in the receive mode.

Fig. 6 is a functional block diagram illustrating the operation of a simplified sixteen element 2-dimensional phased array transducer operating in the transmit mode.

30 Fig. 7 is a functional block diagram illustrating the operation of a simplified sixteen element 2-dimensional time-delay transducer operating in the receive mode.

Fig. 8 is a functional block diagram illustrating the operation of a simplified sixteen element 2-dimensional time-delay transducer operating in the transmit mode.

Fig. 9 is a perspective view illustrating the formation of multiple beams in two planes perpendicular to the face of an array using the time-delay technique.

35 Fig. 10 is a top view of one preferred circular 150 kHz transducer array with 800 individual square faced piezo-electrical ceramic elements closely spaced at a center-to-center distance of 5mm.

Fig. 11 is a perspective view of one preferred embodiment of the transducer assembly with the thickness dimension expanded to illustrate the layered construction thereof.

Fig. 12 is a schematic block diagram of one preferred embodiment of the time-delay receive beamformer used in conjunction with the present invention.

5 Fig. 13 is a schematic block diagram of one preferred embodiment of the time-delay transmit beamformer used in conjunction with the present invention.

Fig. 14 is a graph of signal amplitude versus beam angle (measured from the Z-axis, normal to the array face) for a 150 kHz nominal 32 x 32 phased array transducer, as viewed in the X-Z or Y-Z planes, illustrating the formation of acoustic one beam.

10 Fig. 15 is a process diagram illustrating the preferred manufacturing process for fabricating the preferred array transducer of the present invention.

#### Detailed Description of the Preferred Embodiment

15 Reference is now made to the drawings wherein like numerals refer to like parts throughout. The discussion in this section is organized with headings as follows: Functional Description, Hardware Description and Fabrication Description.

#### 20 1. Functional Description:

A block diagram of the preferred embodiment of the two-dimensional transducer array is shown in Fig. 4. A typical planar acoustic transducer array configuration 100 is depicted. Individual Array elements 102 are electrically interconnected along front-side columns 104 and back-side rows 106. Array elements 102 are interconnected to the associated beamformer 108, 110 through 2-axis transmit/receive (T/R) switches 118. The transmit 108 and receive 110 beamformers may be either phase or time-delay beamforming networks. The coordinate system used for the purposes of this description is as shown with the rows 106 oriented in the X axis, columns 104 in the Y axis, and the Z axis normal to the plane face 116.

30 The array face 116 is circular, but other form factors such as ellipses or polygons which are generally symmetrical in the two face dimensions are also suitable for forming narrow inclined beams of general conical form. The array is composed of a large number of small elements 102 which have symmetrical faces, typically square, circular, or rectangular in form (i.e., their facial cross-section). The face width of each element is approximately  $0.5\lambda$ , where  $\lambda$  is the acoustic wavelength in water of the desired center frequency. To form beams with  $4^\circ$  beam width, an array diameter of approximately  $16\lambda$  is required, consisting of a 32 X 32 element array of approximately 800  
35 elements. The back side rows 106 (X direction) and front side columns 104 (Y direction) of the array elements are

electrically connected together along parallel lines of elements with thin acoustically transparent material, as shown in Fig. 4. The rows and columns are normally but not necessarily orthogonal to each other.

5 Each of the array X axis rows 106 and Y axis columns 104 are connected to a T/R switch 118 which, as controlled by a T/R logic signal 120, electrically connects the sets of X and Y lines to respective X and Y receive beamformers 110 in the receive mode, and to X and Y transmit beamformers 108 in the transmit mode. When in the transmit mode, the array lines are connected through the T/R switch 118 to the transmit beamformers 108 which provide the electrical transmit drive signals from a low impedance electrical source (relative to the electrical impedance of the line of transducer elements). When in the receive mode, the array lines are connected through the  
10 T/R switch to receive beamformers 110 which receive the electrical signals from the transducer lines while providing a low electrical impedance path (relative to the electrical impedance of the line of transducer elements) to signal ground on each X and Y line.

15 This low electrical source/load impedance on each X and Y line (low source impedance during transmit and low load impedance during receive) allows simultaneous and independent access to each X row 106 and Y column 104 for application of transmit electrical drive signals and receipt of signals from each X row and Y column. Furthermore, parallel sets of X and Y axis line arrays can be simultaneously and independently formed. X-axis transmit and receive line arrays are formed by the parallel electrical connection along the back side rows 106 and the presence of the low impedance signal ground on all of the front side Y-axis columns 104.

20 During transmit mode, transmit drive signals are applied through the T/R switch to the parallel X-axis back side electrical interconnection lines from a transmit amplifier which has a low output impedance relative to signal ground. While the X-axis drive signals are being applied to individual X-axis line arrays, the entire Y-axis 32 parallel line array face is maintained as a low impedance path to signal ground (via the signal path through the Y-axis T/R  
25 switch 118a to the low impedance Y-axis drivers of the Y beamformer 108a) to ensure that the X-axis drive signal is imposed solely across the X-axis rows, and does not couple to the Y-axis side of the array. Similarly, while the Y-axis drive signals are being applied to Y-axis line arrays, the entire X-axis array face is maintained as a low impedance path to signal ground to allow signals to be independently applied the Y-axis without coupling to the X-axis. Thus, by superposition of both X and Y axis transmit drive signals, the low impedance associated with the  
30 transmit beamformer sources permits X- and Y-axis line transmit arrays to be formed simultaneously and independently.

35 During receive mode, the electrical signal present on each X-axis row 106 (with the front side low impedance path to signal ground) represents the sum of the received electrical signals of all elements in each row. Most conventional sonar receiver amplifiers provide a high impedance load to the receiving transducer. However, for the 2-dimensional array application of the present invention, an amplifier has been developed for use in the receiving

beamformer which provides a low impedance load while receiving. This is accomplished by connecting each of the X and Y-axis lines to a virtual ground node (a point having the same potential level as ground but not directly connected to ground) on the receiving preamplifier within the receive beamformers. The signal current flowing into each virtual ground node is the sum of the signal currents from all the ceramic elements in the column or row.

5 When receiving signals from a column, the column signal is independent of the row signals being simultaneously received due to the low impedance load presented by the virtual ground on all rows. Similarly, when receiving signals from row, because of the low impedance load presented by the virtual ground on all columns, this row signal is independent of the column signals being simultaneously received.

10 This independent and simultaneous X row and Y column electrical access during both transmit and receive modes via the X and Y signal lines allows the array to be used as a 2-dimensional array to simultaneously and independently form multiple inclined acoustic beam set in both the X-Z and Y-Z planes. The beamforming operation in each plane is the same as conventional 1-dimensional phased and/or time-delay arrays. Thus, the 2-dimensional beamforming operation is in general the equivalent of two overlaid 1-dimensional arrays, with one array rotated 90°.

15 During transmit mode operation, phase or time-delayed signals applied to the X rows form inclined acoustic transmit beams in the Y direction (YZ plane). Simultaneously and independently, phase or time-delayed signals applied to the Y columns to produce inclined acoustic transmit beams in the X direction (XZ plane). During receive mode operation electrical signals received on the X rows are phase or time delayed and combined in the X row receiver beamformer to produce inclined receive acoustic beams in the Y direction. Simultaneously and independently, signals received on the Y columns and combined in the Y side beamformer produce inclined receive acoustic beams in the X direction. Thus, through superposition of the X and Y axis electrical and acoustic signals, 2-dimensional acoustic beam formation from a single planar array in both transmit and receive modes is achieved.

25 To understand the fundamental principles of operation how these two-dimensional transmit and receive acoustic beams are formed, the operation of sixteen element array subset of the 32 X 32 element two-dimensional array transducer is considered. Operation with both phase (narrowband) and time-delay (narrowband or broadband) beamformers is described herein.

### 30 *Phased Array Operation*

Operation of a sixteen-element (4 X 4) subset of the previously described two-dimensional array with a phase-shift beamformer is illustrated in Figs. 5 and 6. During receipt of a long tone burst acoustic signal at a single frequency (narrowband),  $f$ , with wavelength,  $\lambda = c/f$ , where  $c$  is the sound propagation velocity in the fluid media, incoming sound ray wavefronts 200 traveling in the -X direction and at an angle  $\theta$  202 with the Z axis (Z being normal to the array plane, or normal to the plane of the Figure) travel different distances to each of the Y-axis (frontside) column line-arrays 204, and thus strike each of the line arrays at different times, and in general, with

different phases. As illustrated in Fig. 5, the path length differences between adjacent line-arrays ( $\alpha$ ) 206 is related to the element center-to-center separation distance ( $d$ ) by

$$\alpha = d \sin\theta.$$

5

The wavefront arrival time differences ( $\tau$ ) between adjacent line-arrays is

$$\tau = \alpha/c = (d/c)\sin\theta$$

10 If the elements are spaced at distances corresponding to a half-wavelength of the arriving narrowband signal ( $d = \lambda/2$ ), the path length difference expressed in terms of arriving signal wavelengths is given by

$$\alpha = (\lambda/2)\sin\theta.$$

For an arrival angle of  $30^\circ$ ,

15

$$\alpha = (\lambda/2)\sin 30 = \lambda/4.$$

20 This corresponds to an inter-element angular phase shift of  $90^\circ$  for arriving narrowband signals. Thus, when the narrowband pulse is being received by all Y-axis line-arrays with the backside coupled to the low impedance virtual grounds 208 as described above, the received electrical signal phases along the set of four Y-axis line-arrays will be 0, 90, 180, and 270 degrees, respectively.

Receive operation of the frontside (Y) columns with the backside rows 106 all coupled to signal ground in the X-axis receive beamformer 110b will first be considered. Each set of four X-axis electrical signals (in the 4x4 array used for illustration) are connected to virtual ground nodes 208 in the receiver preamplifier of the receive beamformer 110a to form a signal reference for the backside rows, and phase shifted  $-90^\circ$  between adjacent line-arrays (0,  $-90$ ,  $-180$ , and  $-270$  degrees), as shown. The imposed phase shifts compensate for those arising from the different inter-element path lengths of the narrowband acoustic pulse incident on the line arrays, as illustrated in Fig. 5. The resulting four signals 210 will be in phase and, when summed, will form a maximum acoustic interference pattern when receiving a wavefront arriving at a  $30^\circ$  incidence angle. This maximum corresponds to the central axis of one of the main lobes of the formed beams.

35 A second receive beam can be formed for incoming sound ray wavefronts traveling in the  $-X$  direction and at an angle  $\theta$  with the Z direction (at a  $-30^\circ$  incidence angle) by reversing the sign of the  $90^\circ$  imposed phase shift on the four signals and summing the signals. Since the set of four signal phases repeats for additional sets of four line-arrays, larger arrays can be implemented by summing the signals from all sets of four line-arrays to further enhance the interference patterns at  $\pm 30^\circ$ . When additional sets of four line-array segments are utilized as

described, the acoustic signal gain along the  $\pm 30^\circ$  directions is increased, or correspondingly, the beamwidth in that direction is reduced, as additional sets of arrays are added.

5 An equivalent beamforming method is to first sum all of the equal phase signals from different array sets, then apply the imposed  $90^\circ$  phase shifts between the summed set of four signals. This can be accomplished by simply electrically connecting each fourth line-array in parallel, as is commonly done in practice for one-dimensional phased arrays as previously described (see Fig. 2). The effective beamwidth in the X direction is determined by the number of line-array sets in the array. In the Y direction, the beamwidth is determined by the beam patterns of the line-arrays, which is inversely proportional to the length (in acoustic wavelengths) of the array lines. For the ADVS  
10 application, narrow inclined acoustic beams with similar widths in both planes are desired and the X and Y plane dimensions are maintained about the same.

During the transmit mode, operation of the 2-axis array is similar to the above described receive mode except the flow of signals is reversed, as illustrated in Fig. 6. Transmit operation of the frontside columns with the  
15 backside rows all coupled to signal ground will first be considered. A long tone burst carrier frequency 300 is applied to a phase shift transmit beamformer 108a, generating four drive signals with relative phases of 0,  $90^\circ$ ,  $180^\circ$  and  $270^\circ$  degrees. These are applied to the four parallel wired sets 302 of Y columns from low impedance drivers. The imposed phase shifts will compensate for those arising from the different path lengths between line arrays, and a transmitted acoustic signal interference pattern at a  $30^\circ$  incidence angle will be formed, corresponding to the  
20 center of one of the main beam lobes. Another transmitted beam can be formed at a  $-30^\circ$  incidence angle by reversing the sign of the  $90^\circ$  imposed phase shift as previously described.

Receive and transmit operation in the Y-axis is the same. When considering signals applied and received from the backside rows, the frontside columns are coupled through a low impedance to signal ground. The presence  
25 of the low transmit drive and receiver load impedance to ground on each side results in fully independent X and Y axis operation. From superposition of the X and Y axis signals, it can also be seen that both axes (i.e., rows and columns) can be in operation simultaneously.

The above described 2-axis beamforming technique using fixed phase delays in forming narrow transmit and receive beams and is referred to as a "two-dimensional phased array" transducer. It is suitable for use in  
30 narrowband applications which transmit a single frequency (narrowband) long tone burst. Four inclined narrow beams positioned in the X-Z and Y-Z planes and all inclined at an angle relative to the Z direction are formed from a single flat array aperture, as shown in Fig. 3.

From the sound ray diagram in Fig. 5, it is seen that for a fixed element spacing of  $d$ , the angle of each  
35 beam is related to the acoustic frequency by



$$\theta = \sin^{-1}(\lambda/4d) = \sin^{-1}(c/4fd).$$

Thus, the beam angle will be frequency dependent and, if the incoming or outgoing wave has a broad spectrum, the mainlobe beam pattern will be correspondingly broadened in angular space. Because of this bandwidth induced beam spreading, the phased array technique described above does not work with broadband ADVS's which transmit signals with a broad spectrum (typically 20-50% of the carrier frequency). To use this 2-dimensional array method with broadband signals requires an alternate time-delay beamforming method, as described in the following paragraphs.

*Time delay Array operation:*

As previously shown, incoming sound ray wavefronts traveling in the -X direction at a velocity c and at an angle  $\theta$  with the Z direction, strike the various Y-axis front side column line-array locations at different times due to the path length differences between adjacent line-arrays. The path length distance difference,  $\alpha$ , was shown to be equal to  $d \sin\theta$ . The corresponding path length time delay difference ( $\tau$ ) is  $(d \sin\theta)/c$ . While the phased array employs a beamformer which compensates for the inter-element phase delays which apply only for narrowband signals, the time delay array employs a beamformer which compensates for the inter-element time delays which apply for signals of broader frequency band.

Considering now the receive mode of operation of a 4 X 4 array subset as illustrated in Fig. 7, with the backside rows connected to virtual ground in the X-axis receive beamformer 110b, each set of four Y-axis electrical received signals are connected to virtual ground nodes in the receiver beamformer amplifiers 402 to form a signal reference for the backside rows. The amplifier outputs are applied to a tapped bidirectional time-delay summing network 404 as shown in Fig. 7. The imposed inter-element electrical time delay 406,  $\tau$ , compensates for the time delay arising from the different inter-element path lengths of the arriving acoustic signals, resulting in formation of two beams in the  $\pm$  X-axis (X-Z plane) at incidence angles of

$$\theta = \sin^{-1}(c\tau/d).$$

By inspection of this equation, it can be appreciated that the beam angles are now independent of the acoustic frequency, and thus not spatially broadened in space by a broad frequency spectrum. This broadband capability is the primary benefit of the time-delay technique over the previously described phase shift technique.

During the transmit mode, operation of the 4 X 4 array is similar to the above described receive mode except the flow of signals is reversed as illustrated in Fig. 8. Considering first the operation of the frontside columns with the backside rows all coupled to signal ground in the X-axis beamformer 500, the transmit signal 502 is applied to a time delay transmit beamformer 504, generating four drive signals with relative time delays 508 of 0,  $\tau$ ,  $2\tau$ , and  $3\tau$ . These are applied to the four parallel wired sets 506 of Y columns from low output impedance drivers.

The imposed time delays compensate for the time delays arising from the different path lengths between line arrays, and a transmitted acoustic signal interference pattern at an incidence angle  $\theta$  will be formed, corresponding to the center of one of the main beam lobes. Another transmitted beam can be formed at a  $-\theta$  incidence angle by reversing the direction of the signal flow through the time delay network.

5

Time-delay array receive and transmit operation in the other dimension (Y-axis) is completely analogous to that previously described. In Y-axis operation, signals are applied to and received from the backside rows while the frontside columns are coupled through a low impedance to signal ground. The presence of the low transmit drive and receiver load impedance to signal ground on each side results in complete independence of X and Y axis operation; accordingly, both X and Y axes can be in operation simultaneously.

10

For large arrays, the aforementioned time-delay method is more complex to implement than the phase shift method because a separate time delay element is required between each individual line-array, whereas only four discrete phase shifts are required when utilizing the phase shift method. A 32 element time delay network is required for a 32 element array, thereby substantially increasing the complexity of a time delay array over a corresponding phased array of similar size. A further advantage of the time delay approach (in addition to the ability to form narrow beams in broadband operating environments) is that because the beam angle  $\theta$  is determined by  $\sin^{-1}(c\tau/d)$  for a single fixed array physical configuration (element spacing  $d$  being fixed), multiple inclined beams in each axis can easily be formed by using a different set of time delays for each beam set. This concept is illustrated in Fig. 9. In this example, four sets of 4-beam combinations 550 oriented symmetrically about the Z axis 552 at four inclination angles  $\theta$  are achieved by utilizing four sets of X and Y beamformers (BF1X - BF4X 554 and BF1Y - BF4Y 556), each set operating as described above for the basic time-delay array.

15

20

## 2. Hardware Description

25

As can be appreciated from the previous description, the present invention may be embodied to produce many combinations of 2-axis inclined beams with different carrier frequency, beam characteristics and signal bandwidth capabilities. The specific preferred hardware embodiment described in this section employs the time-delay beamformer which was functionally described in the previous section, and produces two narrow beamwidth broadband beams at a 150 kHz carrier frequency in each of two axes for use in ADVS applications.

30

The hardware associated with the preferred embodiment disclosed herein is comprised of a circular transducer array and two substantially identical beamforming networks, each of which provide the electrical signal transfer to form two inclined transmit/receive beams. A top view of the transducer array is provided in Fig. 10. The diameter  $D_{600}$  of the array is approximately 160 mm. There are 800 individual square faced 150 kHz piezo-electrical ceramic elements 102 closely spaced at a center to center distance of 5 mm 604 (about 1/2 wavelength at 150 kHz, based on a propagation velocity of roughly 1500 m/s).

35

The multilayer construction of the transducer array is illustrated in the three dimensional view shown in Fig. 11. This thickness dimension in this view is expanded to show the layered structure. The ceramic array elements 700, e.g., the 800 elements 102 shown in Figure 10 are electrically and mechanically connected by two pieces of thin, acoustically transparent flexible printed circuits (FPC) 702, 704 on the top and bottom surfaces of the ceramics. Such circuits may be fabricated from Kapton™ (polyimide) or other suitable material. Electrical connection to each ceramic element 700 is achieved by press fitting and bonding (or alternatively, low temperature soldering) the printed electrical conductor lines to the conductive face of the array elements. Bonding may be accomplished by use of a suitable adhesive or glue, although it can be appreciated that other forms of bonding may also be suitable. The connection pattern is along element columns on the front side and along rows on the back side, with access to columns on one side (Y wires 705) and rows on another side (X wires 707). A piece of 1/8 inch (3.18 mm) thick fiberglass material 706 (such as that bearing the tradename "G-10" or other similar material) with face dimensions matching the ceramic is bonded to the front of the top flexible circuit on each 150 kHz transducer array. This fiberglass (G-10 or equivalent) piece is an acoustic quarter wave transformer used to improve the impedance coupling between the array and water, and to significantly increase the transducer element bandwidth. The significant increase in the transducer bandwidth is required by the broadband ADVS technology. A layer of urethane 708 bonded to the front of the fiberglass piece seals the face to the water in front. A layer of air filled cardboard 710 is placed between the back plane of the housing 712 and the back of the bottom flexible circuit to reflect the acoustic energy transmitted backward and to provide the necessary mechanical support against the water pressure incident on the front of the transducer array surface 714.

The preferred time-delay receive mode beamformer circuitry (one axis only) is illustrated in Fig. 12. In the receive mode of operation, the received signals from all frontside columns and backside rows 104, 106 are coupled to the X and Y axis beamformers 110a, 110b, respectively, through T/R switches 118. Each T/R switch is implemented with a Field Effect Transistor (FET) 806 in series with the receiver amplifier input terminals 808. A virtual ground low impedance load on all X and Y lines during receive mode operation is implemented with a high gain differential preamplifier 810 which has a low noise figure when coupled to the relatively low impedance transducer line arrays. Each X and Y transducer line array is connected to the negative terminal of the high input impedance differential amplifier, the positive terminal is connected to signal ground 812, and a feedback impedance 814 is connected between the low impedance preamplifier output and the negative input terminal. This forms a well known inverting operational amplifier configuration (the resulting gain of the amplifier is proportional to the negative of the ratio of the feedback impedance to source impedance 816) with the transducer line array providing the input signal with a source impedance 816 equal to the electrical impedance of the line array. If the amplifier open loop gain is much higher than the closed loop gain determined by the ratio of the feedback resistor to the source impedance of each 150 kHz line array ( $\approx 200$  ohms), the voltage across the input terminals will be small with respect to the received signal. Since the positive amplifier terminal is grounded, the negative terminal is maintained by the amplifier

loop action at essentially ground potential also. Thus, the negative terminal input 808 is considered a "virtual" ground.

5 The output of the preamplifier is converted to a high output impedance current source via a transistor 818 which injects the signal current derived from the line array into a tapped analog time-delay summing network 404. This network has 32 taps (corresponding to each of the 32 rows or columns used in each dimension); each segment between the taps has a time delay of  $t$  microseconds, corresponding to the delay required to compensate for the  $t$  microsecond acoustic time delay occurring for arriving and departing signals at the line arrays at the chosen angle of incidence. Each time-delay segment is implemented with a four-component inductor/capacitor network 822 which  
10 approximates a second order all-pass filter. This inductor/capacitor network provides an approximation of a wide bandwidth time delay which is accurate to 0.1% over a 25% bandwidth.

The above description applies to the receive beamformer associated with one of the two axes of a 2-axis array. It can be appreciated that a corresponding set of receive beamformer electrical hardware is utilized for  
15 processing the receive signals for the other axis.

Fig. 13 shows the preferred time-delay transmit beamformer (one axis only) associated with the present invention. The transmit beamformer time delays are achieved with digital circuits and square waveforms to simplify the circuits and achieve precise time delays determined by an accurate clock signal. TB1 and TB2 850 are square  
20 waveforms at the frequency to be transmitted by the four acoustic beams. For each of the 32 rows, TB1 and TB2 are summed together by summing circuits 851 after an appropriate time delay (achieved through use of 32 bit shift registers 852) and applied to the 32 array rows through the transmit amplifiers 854. Harmonics associated with the square wave output signals of the transmit amplifiers are attenuated by the bandpass characteristics of the transducer array row or column 856; the transmitted signal is therefore dominated by the fundamental transmit  
25 frequency. The transmit amplifiers are implemented with low impedance FET push/pull output stages 858 which have a low output impedance when driving the transducers. During receive mode operation, a high output impedance load is supplied by turning both push/pull stages off.

During the transmit mode, the electrical potential between the two faces of each ceramic element is  
30 determined by the summation of four appropriately delayed waveforms: the two row drive signals (TB1 and TB2) described above, and a corresponding set of time-delayed column drive signals (TB3 and TB4). Four inclined acoustic beams in 2 axes (X-Z and Y-Z planes) will be generated with these time delayed drive waveforms.

The time delay array forms four transmit and receive beams each with a  $4^\circ$  beam width (based on two  
35 side, 3 dB downpoints). Fig. 14 is a graph of signal amplitude versus beam angle (measured from the Z-axis, normal to the array face) for a 150 kHz nominal 32 x 32 phased array transducer, as viewed in the X-Z or Y-Z planes,

illustrating the formation of one acoustic beam 900. As shown, the sidelobe attenuation at the neighbor and opposite beam position (-+ 30 degree beam angle, 904) is about -40 dB.

### 3. Fabrication Description:

5           Another aspect of the present invention relates to a unique method of manufacturing a transducer array suitable for use in such a multiple beam sonar in an economical manner, and which preserves the precise geometrical relationships among the elements. This method is described in detail in the following paragraphs.

10           For high frequency arrays as previously described, the diameter of the individual transducer elements and the distance between the individual transducer elements is small, e.g., < 5 mm, and a large number of precisely placed elements are required. Since it is not practical to assemble this many small individual elements into the array, the elements must remain in their original position during and after dicing, and must be electrically connected as previously described. Therefore, one cannot simply glue the ceramic element, fiberglass, acoustically transparent Flexible Printed Circuit (FPC), and backing material together and then cut it into the desired number of pieces. A  
15           reliable and economical method of manufacturing the 2-axis transducer array which preserves precise geometrical relationships among the elements is required.

20           The preferred process used to manufacture the preferred embodiment of the present invention is illustrated in Fig. 15. The necessary components for assembly of the preferred transducer array include a cylindrical solid fiberglass element 706 (G-10 or equivalent), front side (Y-axis) Y FPC sheets 702, a cylindrical ceramic element 700, back side (X-axis) X FPC sheets 704, a cardboard backing layer 710, and a urethane layer 708. A cup housing may also be utilized to house the transducer array assembly when the fabrication process is completed. Note that other forms such as ellipses or polygons which are generally symmetrical in the two face dimensions are also suitable for use in lieu of the aforementioned cylindrical shapes.

25           The fabrication process generally involves use of a parallel blade diamond saw to slice through the front and back sides of a solid piece of ceramic and an attached impedance layer to create electrically and mechanically independent elements. This is done in such a way that all array elements are held in place during and after slicing to preserve precise geometrical relationships among the elements. Specifically, the disclosed process for  
30           manufacturing the preferred embodiment of the present invention is as follows, with reference being made to Fig. 15:

1.           First, a parallel blade diamond saw (not shown) is used to slice the front face of the fiberglass matching layer 706 halfway through its thickness, defined by the Z-axis, in the X and Y directions.
- 35           2.           Second, a layer of acoustically transparent urethane 708 is bonded to the front face of the fiberglass matching layer 706.

3. The diamond saw is then used to slice the back side of the fiberglass matching layer 706 through its remaining thickness in both the X and Y directions.

4. Next, the diamond saw is used to slice the back face of the transducer array blank 700 halfway through its thickness, defined by the Z axis, in the X and Y directions.

5 5. A thin layer of X-axis conducting foil (X FPC) 704 is then bonded on the back face of the blank 700.

6. A layer of backing material 710 is next bonded to the back face of the X-FPC 704.

7. The front face of the blank 700 is next sliced through its remaining thickness (Z direction) in the X and Y directions.

10 8. A thin layer of Y-axis conducting foil (Y FPC) 702 is then bonded on the front face of the ceramic/X FPC transducer assembly.

9. Finally, the sliced fiberglass matching layer/urethane assembly 706, 708 and ceramic/FPC/backing assembly 700, 702, 704, 710 are bonded together as shown.

15 A cup housing or other support element may subsequently be fitted as required to provide for mounting the transducer array to the desired platform (such as a ship hull or current profiler) and sealing against water intrusion. It can be appreciated that a large number of different housing designs and sealing mechanisms may be utilized in conjunction with the present invention to fulfill these needs.

20 While the above detailed description has shown, described, and pointed out the fundamental novel features of the invention as applied to various embodiments, it will be understood that various omissions, substitutions, and changes in the form and details of the device or process illustrated may be made by those skilled in the art without departing from the intent of the invention.

25

WHAT IS CLAIMED IS:

1. An acoustic system, comprising:  
a plurality of transducer elements arranged to form a single two-dimensional array, wherein the elements  
5 are electrically connected into rows in a first dimension and columns in a second dimension and the rows are electrically independent of the columns;  
a first beamforming circuit forming a first plane of acoustic beams projected outside of the array plane and substantially normal to the first transducer array dimension, the first beamforming circuit electrically connected to the transducer elements in the second transducer array dimension, wherein the first beamforming circuit delays  
10 signals associated, respectively, with each column; and  
a second beamforming circuit forming a first plane of acoustic beams projected outside of the array plane and substantially normal to the second transducer array dimension, the second beamforming circuit electrically connected to the transducer elements in the first array dimension, wherein the second beamforming circuit delays signals associated, respectively, with each row, the system thereby capable of forming at least two planes of  
15 acoustic beams.
2. The acoustic system of Claim 1, wherein the acoustic beams formed by the system are in the Janus configuration.
3. The acoustic system of Claim 1, wherein the transducer elements are arranged to substantially form a pattern selected from the group consisting of circular, elliptical or polygonal shapes.
- 20 4. The acoustic system of Claim 1, wherein the rows and columns are orthogonal to one another.
5. The acoustic system of Claim 1, wherein each transducer element has a facial cross-section selected from the group consisting of a circular, elliptical or polygonal shapes.
6. The acoustic system of Claim 1, wherein the transducer elements are arranged within the array such that the centerline-to-centerline distance between individual elements is one-half of the wavelength of the system acoustic carrier frequency as measured in water and at the front face of the array.  
25
7. The acoustic system of Claim 1, wherein the first and second beamforming circuits include multiple bit shift registers.
8. The acoustic system of Claim 1, wherein each transducer element is symmetric in the facial plane.
9. The acoustic system of Claim 1, wherein the first and second beamforming circuits provide a  
30 virtual ground load impedance to all rows and columns, respectively when the system is receiving signals.
10. The acoustic system of Claim 1, wherein the first and second beamforming circuits provide a low source impedance to all rows and columns, respectively when the system is transmitting signals.
11. The acoustic system of Claim 1, wherein the rows and columns of transducer elements are electrically connected into P sets of elements by interconnecting each Pth row and column, the first and second  
35 beamforming circuits being electrically connected to these P sets of rows and columns, respectively.

12. An electro-acoustic transducer capable of forming multiple transmit or receive acoustic beams from a single planar aperture, comprising:

a plurality of transducer elements arranged in a planar array of N substantially parallel rows and M substantially parallel columns, each row of transducer elements being electrically connected along a first face of the array, and each column of transducer elements being electrically connected along a second face;

a first transmit/receive beamformer electrically connected to the rows;

a second transmit/receive beamformer electrically connected to the columns and operating in electrical independence of the first beamformer,

a transmit/receive switch electrically connected, respectively, between the first and second beamformers and the rows and columns,

wherein a transmit setting of the switch allows the first and second beamformers to apply signals to the rows and columns of transducer elements, respectively, to form the transmit beams, the signals being time- or phase-delayed, and,

wherein a receive setting of the switch allows the first and second beamformers to receive signals from the row and column transducer elements, respectively, the signals from the rows and columns being, respectively, time- or phase-delayed and combined to form the receive beams.

13. The transducer of Claim 12, wherein the acoustic beams formed by the system are in the Janus configuration.

14. The transducer of Claim 12, wherein the transducer elements are arranged to substantially form a pattern selected from the group consisting of circular, elliptical or polygonal shapes.

15. The transducer of Claim 12, wherein the rows and columns are orthogonal to one another.

16. The transducer of Claim 12, wherein each transducer element has a facial cross-section selected from the group consisting of a circular, elliptical or polygonal shapes.

17. The transducer of Claim 12, wherein the transducer elements are arranged within the array such that the centerline-to-centerline distance between individual elements is one-half of the wavelength of the system acoustic carrier frequency as measured in water and at the front face of the array.

18. The transducer of Claim 12, wherein the transmit/receive beamformer includes multiple bit shift registers.

19. The transducer of Claim 12, wherein each transducer element is symmetric in the facial plane.

20. The transducer of Claim 12, wherein the first and second transmit/receive beamformers provide a virtual ground load impedance to all rows and columns, respectively when the transmit/receive switch is positioned to receive signals.

21. The transducer of Claim 12, wherein the first and second transmit/receive beamformers provide a low source impedance to all rows and columns, respectively when the transmit/receive switch is positioned to transmit signals.



22. The transducer of Claim 12, wherein the rows and columns of transducer elements are electrically connected into P sets of elements by interconnecting each Pth row and column, the first and second transmit/receive beamformers being electrically connected to these P sets of rows and columns, respectively.

23. A method of forming multiple transmit or receive beams from a single planar array having a plurality of transducer elements arranged in N substantially parallel rows and M substantially parallel columns, wherein the planar array has a first transmit/receive beamformer electrically connected to the rows, a second transmit/receive beamformer electrically connected to the columns, and a transmit/receive switch electrically connected, respectively, between the first and second beamformers and the rows and columns, the method comprising the steps of:

setting the transmit/receive switch to a transmit setting; and  
applying signals from the first and second beamformers to the rows and columns of transducer elements, respectively, to form transmit beams, the signals being time- or phase-delayed, or, alternatively,  
setting the transmit/receive switch to a receive setting; and  
allowing signals from the rows and columns of transducer elements to be applied to the first and second beamformers, respectively, with a time- or phase-delay, to form receive beams.

24. The method of Claim 23, wherein the acoustic beams formed by the system are in the Janus configuration.

25. The method of Claim 23, wherein the transducer elements are arranged to substantially form a pattern selected from the group consisting of circular, elliptical or polygonal shapes.

26. The method of Claim 23, wherein the rows and columns are orthogonal to one another.

27. The method of Claim 23, wherein each transducer element has a facial cross-section selected from the group consisting of a circular, elliptical or polygonal shapes.

28. The method of Claim 23, wherein the transducer elements are arranged within the array such that the centerline-to-centerline distance between individual elements is one-half of the wavelength of the system acoustic carrier frequency as measured in water and at the front face of the array.

29. The method of Claim 23, wherein the transmit/receive beamformer includes multiple bit shift registers.

30. The method of Claim 23, wherein each transducer element is symmetric in the facial plane.

31. The method of Claim 23, wherein the first and second transmit/receive beamformers provide a virtual ground load impedance to all rows and columns, respectively when the transmit/receive switch is positioned to receive signals.

32. The method of Claim 23, wherein the first and second transmit/receive beamformers provide a low source impedance to all rows and columns, respectively when the transmit/receive switch is positioned to transmit signals.

33. The method of Claim 23, wherein the rows and columns of transducer elements are electrically connected into P sets of elements by interconnecting each Pth row and column, the first and second transmit/receive beamformers being electrically connected to these P sets of rows and columns, respectively.

34. The method of Claim 23, wherein the rows and columns of the planar array simultaneously form  
5 either transmit or receive beams in two planes.

35. A method of fabricating an acoustic transducer having a plurality of elements comprising the steps  
of:

providing a transducer blank having first and second substantially parallel faces;

slicing said transducer blank partway through its thickness in one or more dimensions of said first face;

10 bonding said first face of said transducer blank to a substantially rigid member, said member providing for the electrical connection of one or more of said elements; and

slicing said transducer blank in one or more dimensions of said second face, said slicing of said second face spatially coinciding with the slicing of said first face such that said blank is sliced completely through its thickness, thereby forming individual transducer elements from said blank, each of said elements being bonded to said  
15 substantially rigid member.

36. The method of Claim 35, wherein the transducer blank consists of lead-zircon-titanate.

37. The method of Claim 35, wherein the faces of the transducer blank have a cross-section selected from the group consisting of circular, elliptical, square, polygonal, or rectangular shapes.

38. An electro-acoustic transducer capable of simultaneously forming multiple transmit or receive  
20 acoustic beams in first and second orthogonal planes and from a single planar aperture, comprising:

a plurality of transducer elements arranged in a planar array of N substantially parallel rows and M substantially parallel columns, each row of transducer elements being electrically connected along a first face of the array, and each column of transducer elements being electrically connected along a second face;

a first transmit/receive beamformer electrically connected to the rows;

25 a second transmit/receive beamformer electrically connected to the columns and operating in electrical independence of the first beamformer,

a transmit/receive switch electrically connected, respectively, between the first and second beamformers and the rows and columns,

30 wherein a transmit setting of the switch allows the first and second beamformers to apply signals to the rows and columns of transducer elements, respectively, to form multiple transmit beams within the first and second orthogonal planes, respectively, the beams being at the same angle of inclination relative to a direction normal to the to first and second faces of the planar array, the signals being time- or phase-delayed, and,

35 wherein a receive setting of the switch allows the first and second beamformers to receive signals from the row and column transducer elements, respectively, the signals from the rows and columns being, respectively, time- or phase-delayed and combined to form receive beams oriented within the first and second orthogonal planes,

the beams being at the same angle of inclination relative to a direction normal to the first and second faces of the planar array.

39. An electro-acoustic system capable of simultaneously transmitting or receiving multiple acoustic beams in a fluid media, comprising:

5 a plurality of transducer elements arranged to form a single two-dimensional array wherein the elements are electrically connected on a first array face in N rows in a first direction, and on a second array face in M columns in a second direction, the connection on the first and second faces being electrically independent;

10 a first transmit/receive beamformer electrically interfaced to the N rows, wherein signals applied to or received from the rows are electrically independent of signals simultaneously applied to or received from the columns;

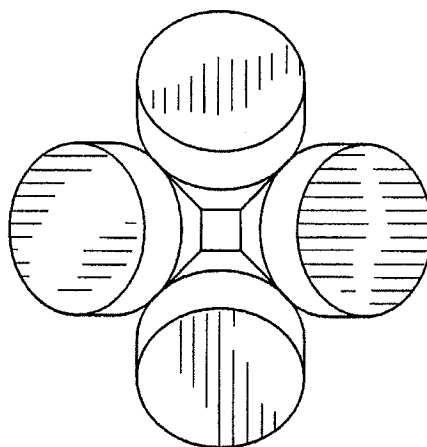
15 a means for operating the first transmit/receive beamformer in a transmit mode, wherein the first beamformer generates a set of N electrical signals, each signal being time- or phase-delayed, and applies each electrical signal to its respective transducer row element, thereby forming a set of multiple transmit acoustic beams inclined outward from a direction normal to the first and second faces, and positioned within a plane oriented normal to the first direction;

20 a means for operating the first transmit/receive beamformer in a receive mode wherein the first beamformer receives a set of electrical signals corresponding to each of the N rows and applies a time or phase delay to each signal, the resulting time-or phase-delayed signals from each row being combined together to form a set of multiple receive acoustic beams inclined outward from a direction normal to the first and second faces, and positioned within a plane oriented normal to the first direction;

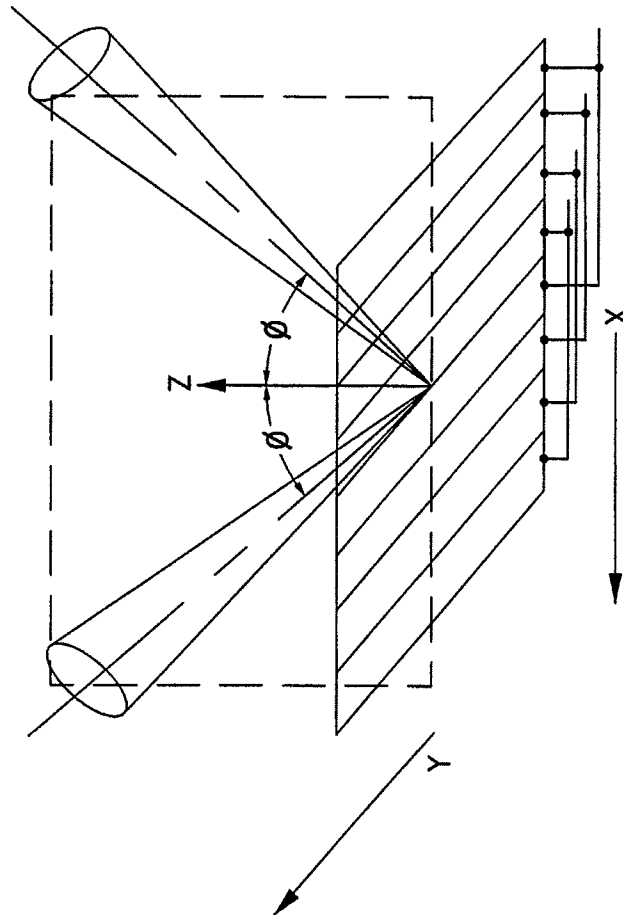
25 a means for operating the second transmit/receive beamformer in a transmit mode, wherein the second beamformer generates a set of M electrical signals, each signal being time- or phase-delayed, and applies each electrical signal to its respective transducer column element, thereby forming a set of multiple transmit acoustic beams inclined outward from a direction normal to the first and second faces, and positioned within a plane oriented normal to the second direction; and

30 a means for operating the second transmit/receive beamformer in a receive mode wherein the second beamformer receives a set of electrical signals corresponding to each of the M columns and applies a time or phase delay to each signal, the resulting time-or phase-delayed signals being combined together to form a set of multiple receive acoustic beams inclined outward from a direction normal to the first and second faces, and positioned within a plane oriented normal to the second direction.

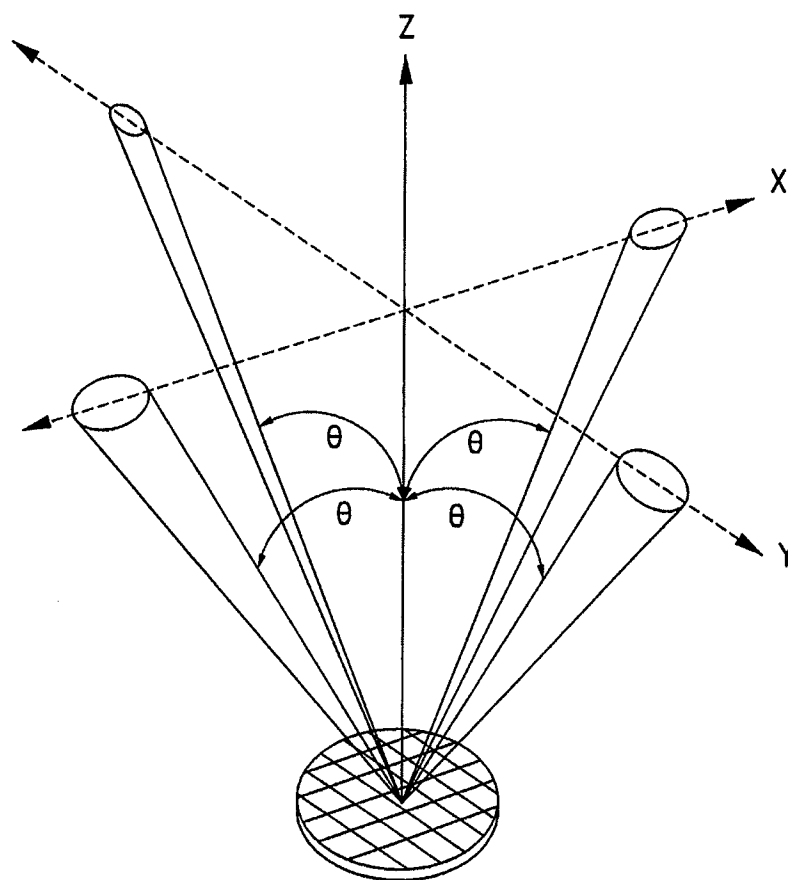
35



*FIG. 1*  
*(PRIOR ART)*



*FIG. 2*  
*(PRIOR ART)*



*FIG. 3*

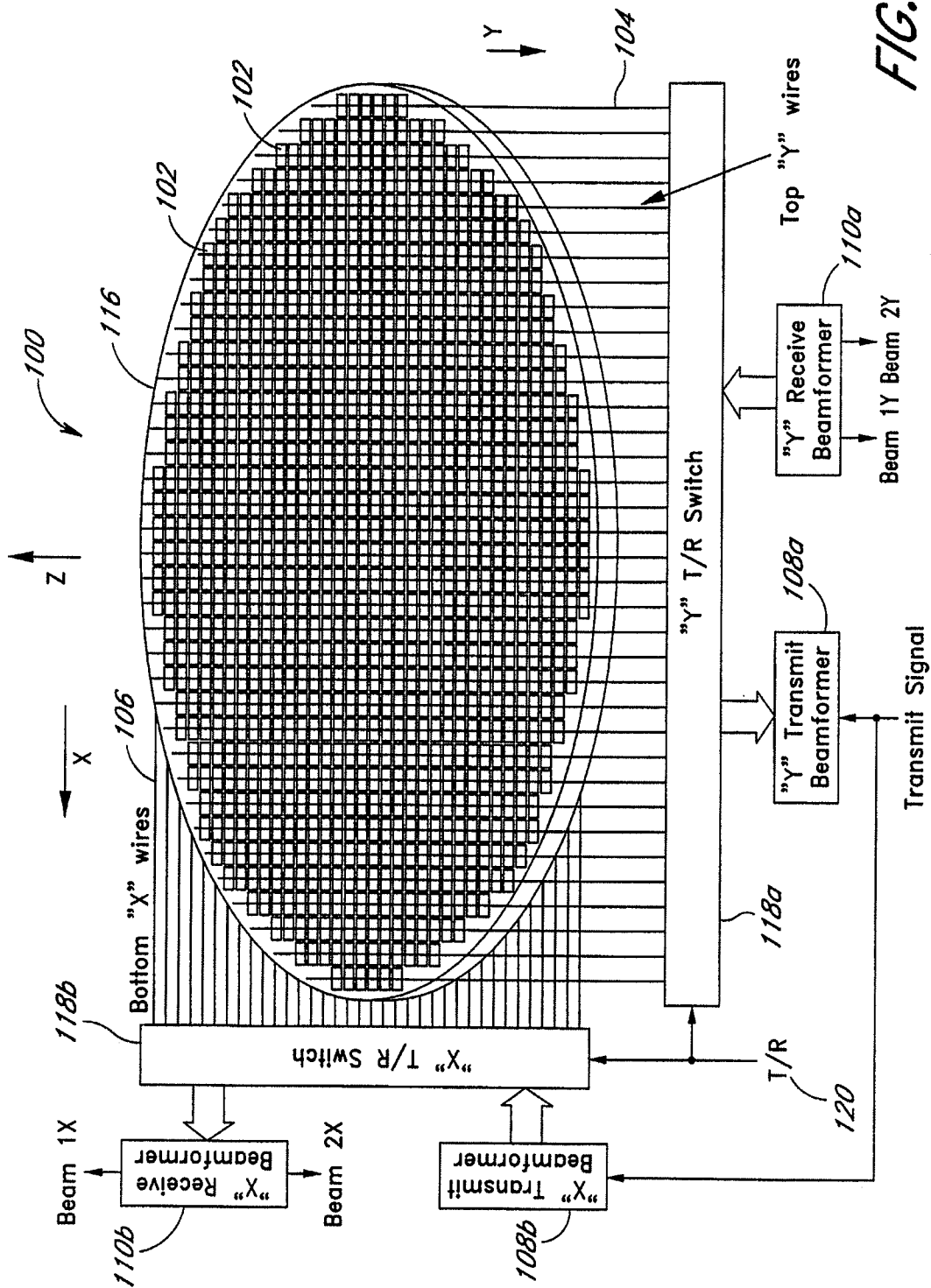


FIG. 4

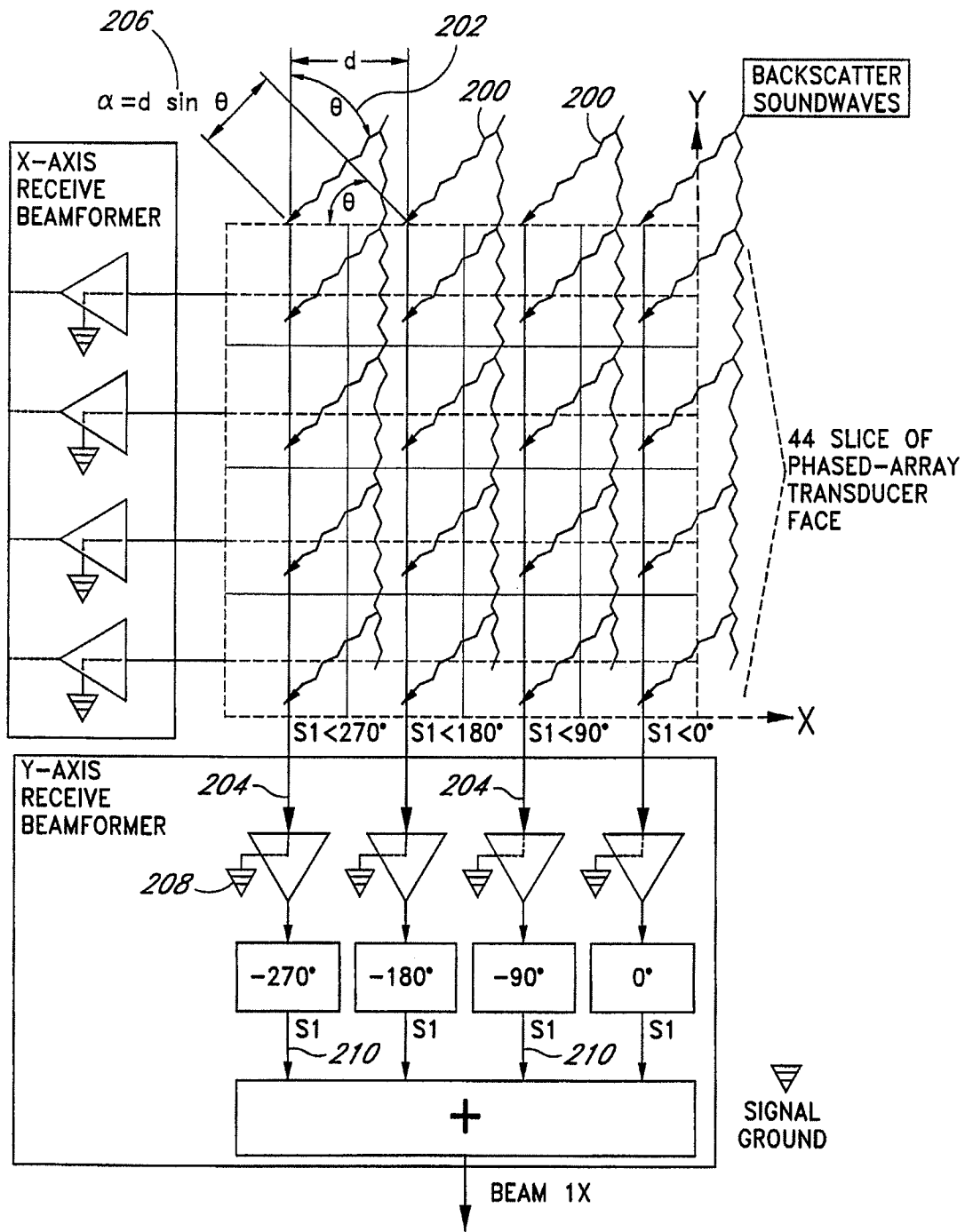


FIG. 5



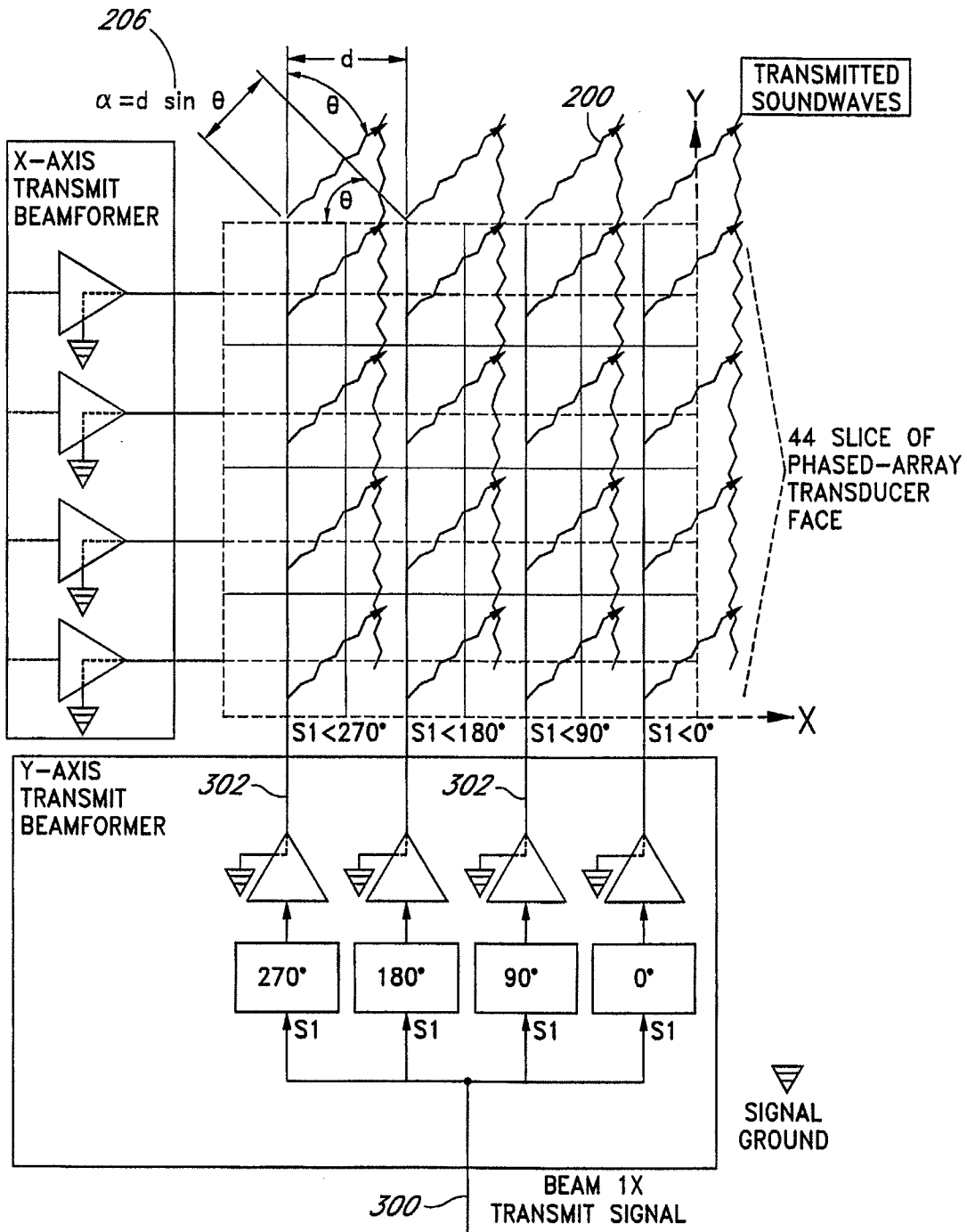


FIG. 6

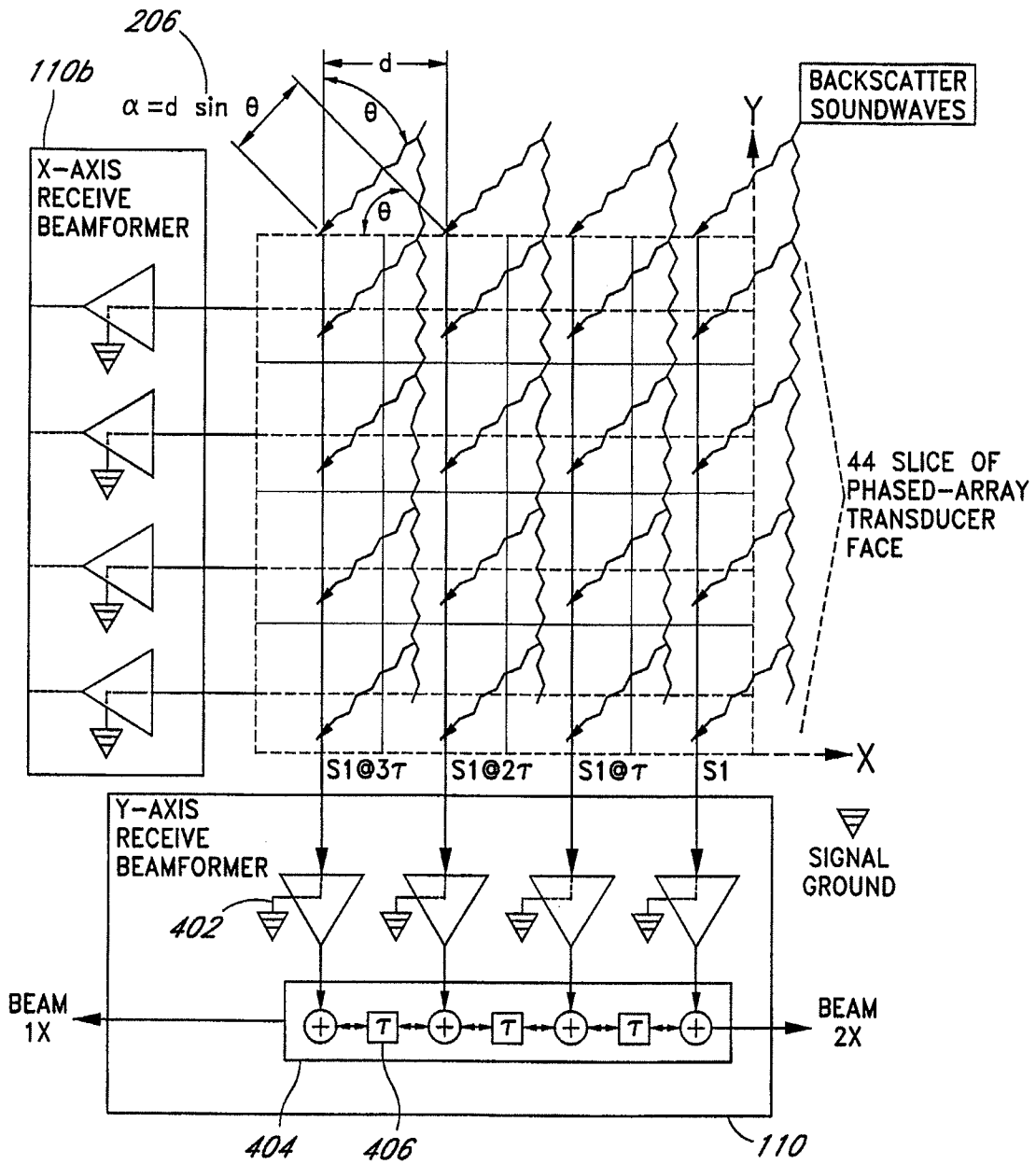


FIG. 7

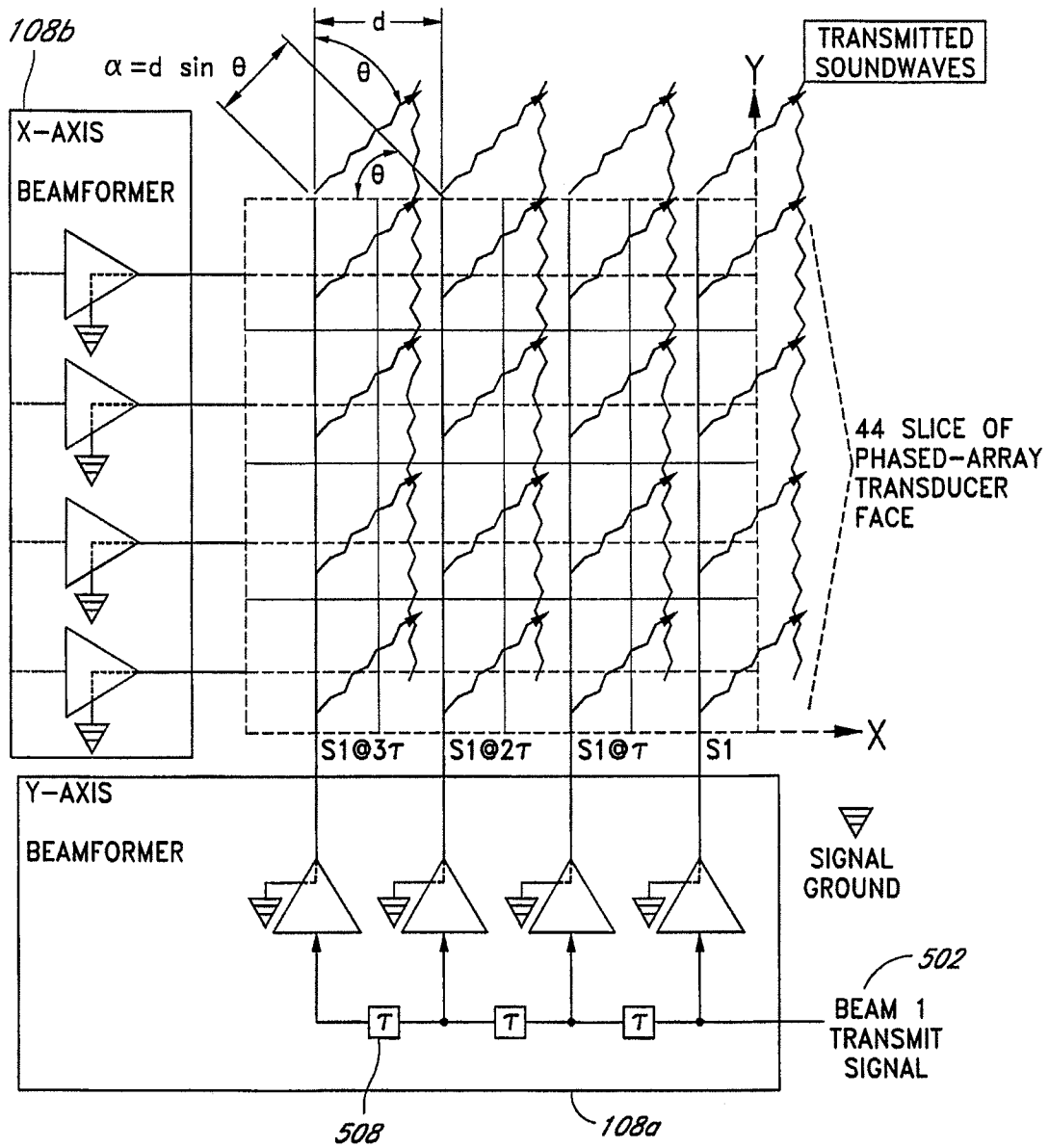


FIG. 8

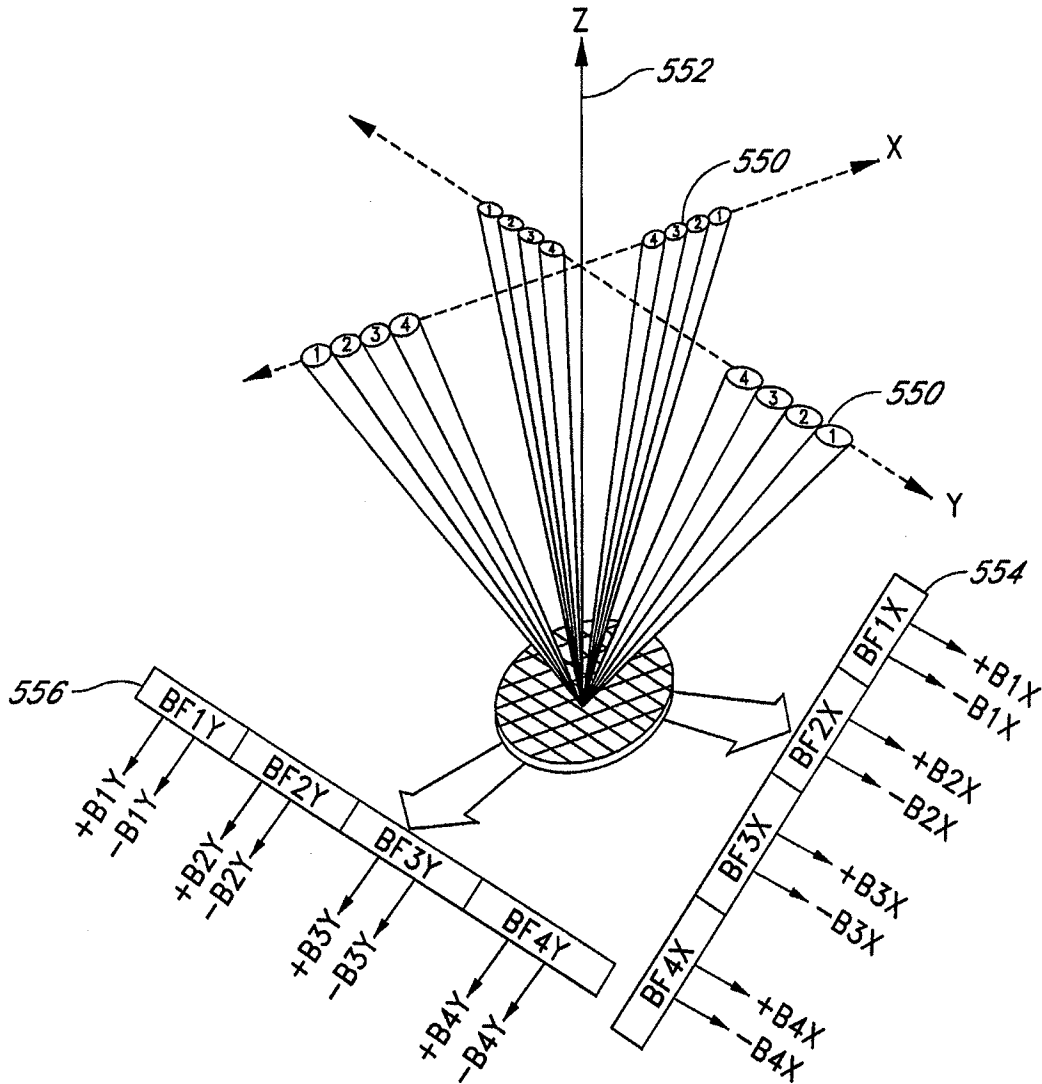
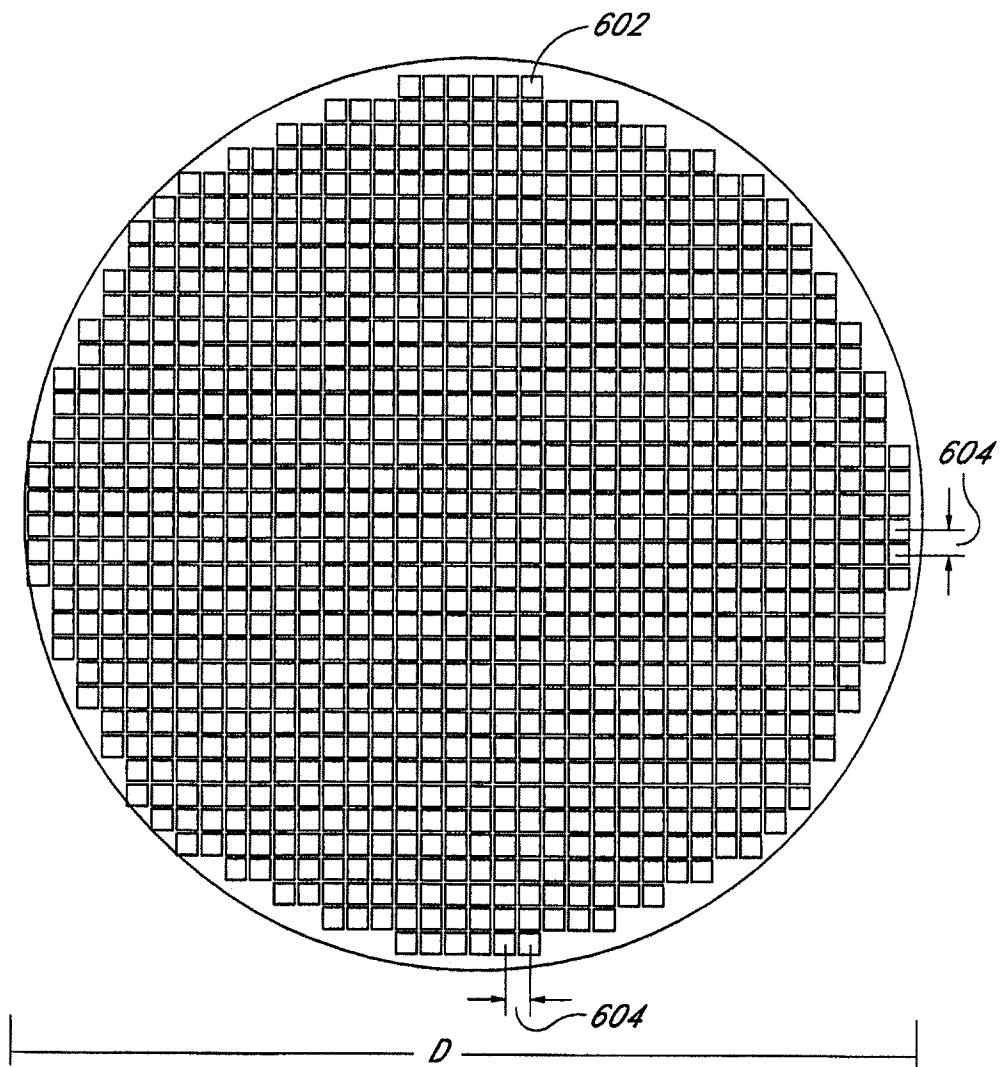


FIG. 9



*FIG. 10*

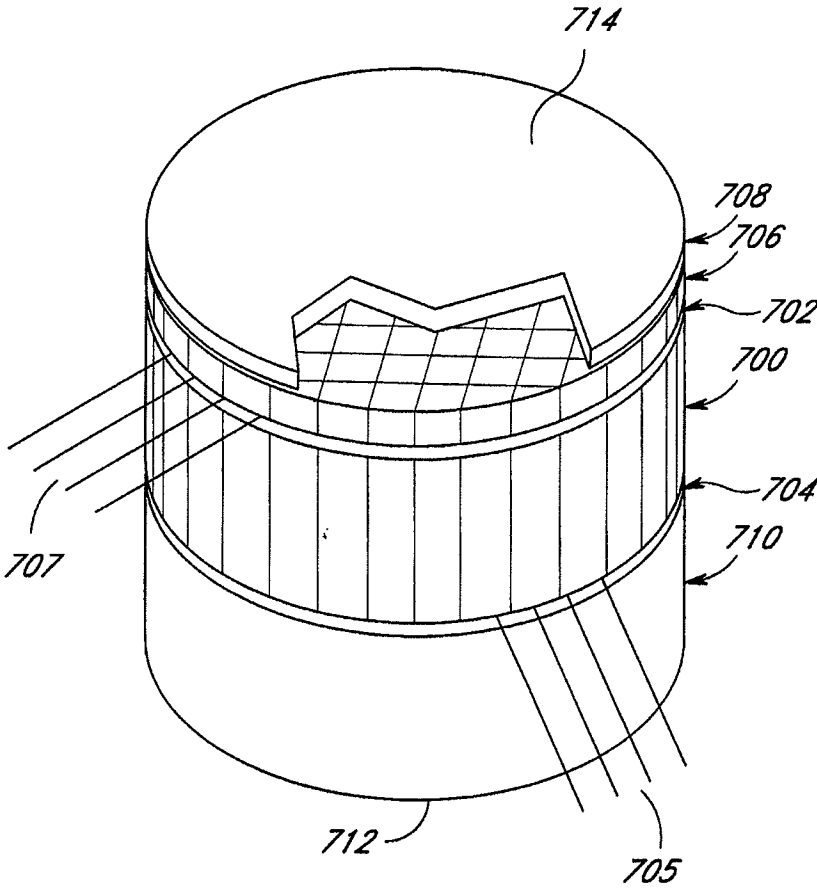


FIG. 11

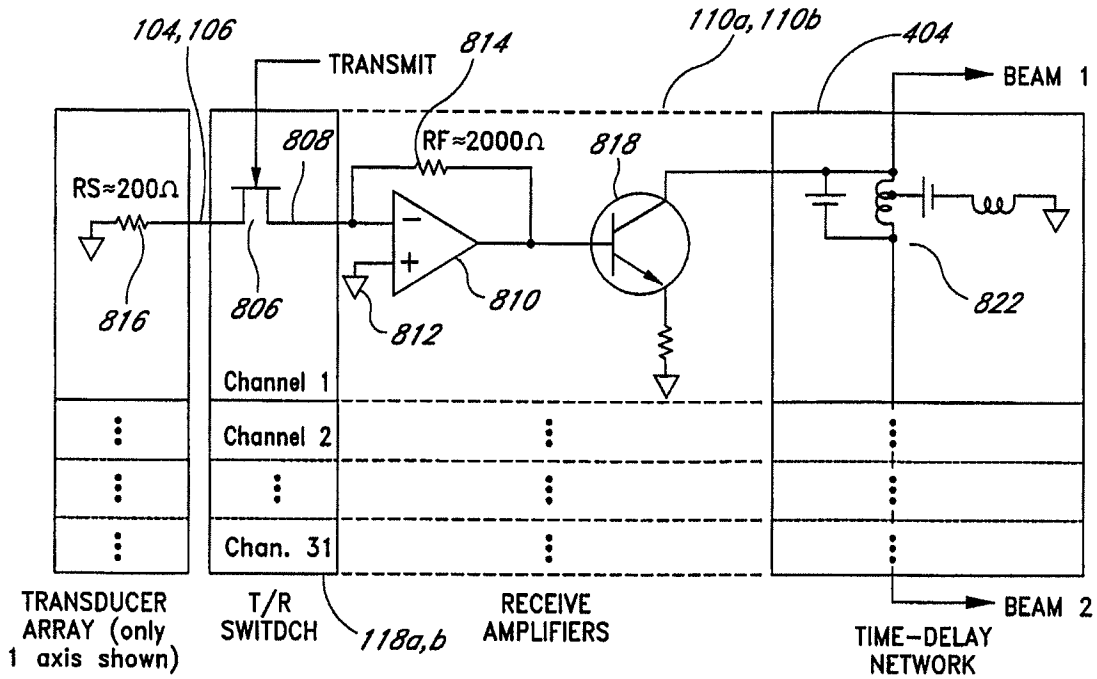


FIG. 12

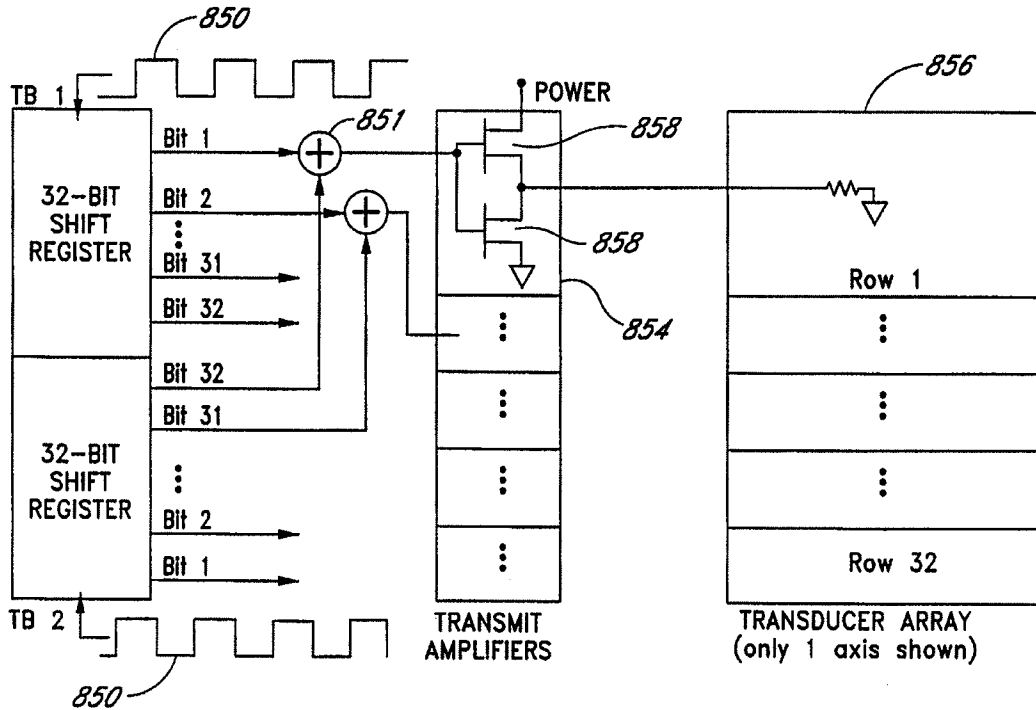


FIG. 13

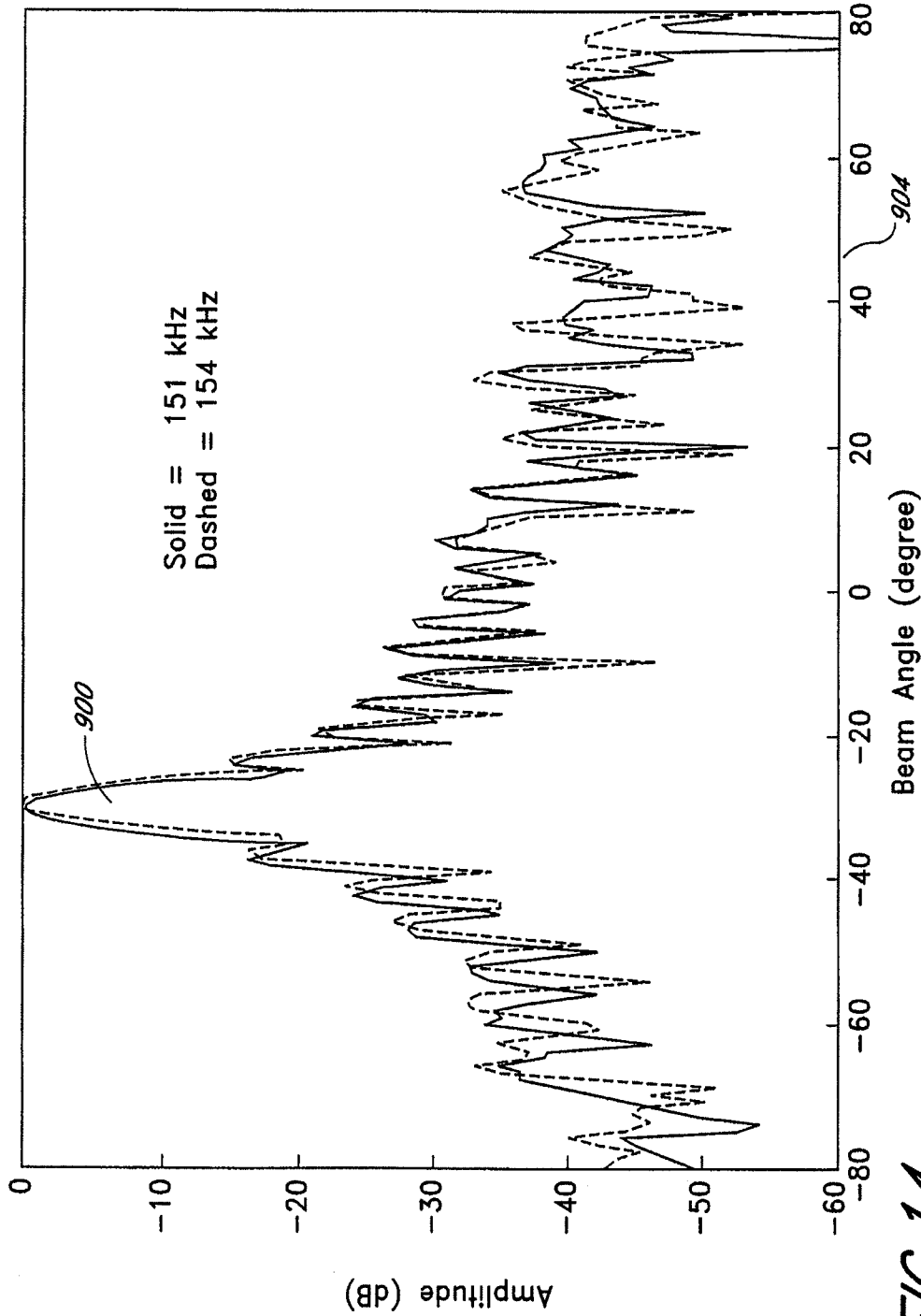


FIG. 14



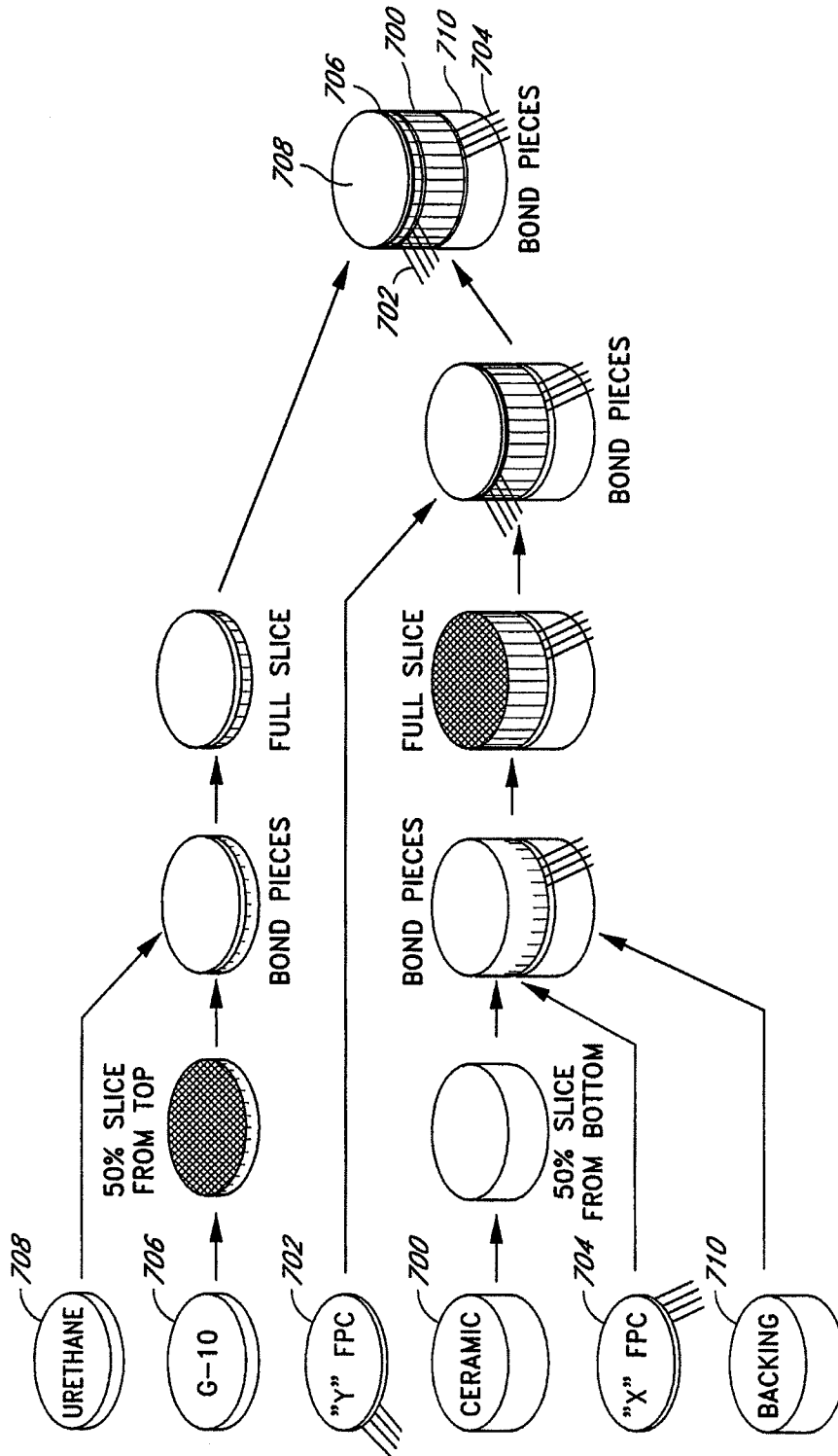


FIG. 15

# INTERNATIONAL SEARCH REPORT

International Application No  
PCT/US 97/18061

<b>A. CLASSIFICATION OF SUBJECT MATTER</b> IPC 6 G01S15/60 G01S15/89				
According to International Patent Classification (IPC) or to both national classification and IPC				
<b>B. FIELDS SEARCHED</b> Minimum documentation searched (classification system followed by classification symbols) IPC 6 G01S G10K H04R B06B				
Documentation searched other than minimum documentation to the extent that such documents are included in the fields searched				
Electronic data base consulted during the international search (name of data base and, where practical, search terms used)				
<b>C. DOCUMENTS CONSIDERED TO BE RELEVANT</b>				
Category <sup>o</sup>	Citation of document, with indication, where appropriate, of the relevant passages	Relevant to claim No.		
Y	US 5 550 792 A (CRANDALL F ANTHONY ET AL) 27 August 1996  see column 2, line 58 - column 3, line 24; figures 4,5,9  ---	1-4,12, 23,35, 38,39		
Y	SHAULOV A ET AL: "BIPLANE PHASED ARRAY FOR ULTRASONIC MEDICAL IMAGING" PROCEEDINGS OF THE ULTRASONICS SYMPOSIUM, CHICAGO, OCT. 2 - 5, 1988, vol. 1, 2 October 1988, MCAVOY B R, pages 635-638, XP000077019 see page 635, right-hand column; figure 1  ---	1-4		
Y	US 4 641 291 A (SIMMONS SR ROBERT L ET AL) 3 February 1987 cited in the application see column 3 - column 4; figure 10  ---	1-4,12, 23,35, 38,39		
-/--				
<input checked="" type="checkbox"/> Further documents are listed in the continuation of box C.				
<input checked="" type="checkbox"/> Patent family members are listed in annex.				
<sup>o</sup> Special categories of cited documents :				
<table style="width: 100%; border: none;"> <tr> <td style="width: 50%; border: none; vertical-align: top;">                     *A* document defining the general state of the art which is not considered to be of particular relevance                      *E* earlier document but published on or after the international filing date                      *L* document which may throw doubts on priority claim(s) or which is cited to establish the publication date of another citation or other special reason (as specified)                      *O* document referring to an oral disclosure, use, exhibition or other means                      *P* document published prior to the international filing date but later than the priority date claimed                 </td> <td style="width: 50%; border: none; vertical-align: top;">                     *T* later document published after the international filing date or priority date and not in conflict with the application but cited to understand the principle or theory underlying the invention                      *X* document of particular relevance; the claimed invention cannot be considered novel or cannot be considered to involve an inventive step when the document is taken alone                      *Y* document of particular relevance; the claimed invention cannot be considered to involve an inventive step when the document is combined with one or more other such documents, such combination being obvious to a person skilled in the art.                      *&amp;* document member of the same patent family                 </td> </tr> </table>			*A* document defining the general state of the art which is not considered to be of particular relevance *E* earlier document but published on or after the international filing date *L* document which may throw doubts on priority claim(s) or which is cited to establish the publication date of another citation or other special reason (as specified) *O* document referring to an oral disclosure, use, exhibition or other means *P* document published prior to the international filing date but later than the priority date claimed	*T* later document published after the international filing date or priority date and not in conflict with the application but cited to understand the principle or theory underlying the invention *X* document of particular relevance; the claimed invention cannot be considered novel or cannot be considered to involve an inventive step when the document is taken alone *Y* document of particular relevance; the claimed invention cannot be considered to involve an inventive step when the document is combined with one or more other such documents, such combination being obvious to a person skilled in the art. *&* document member of the same patent family
*A* document defining the general state of the art which is not considered to be of particular relevance *E* earlier document but published on or after the international filing date *L* document which may throw doubts on priority claim(s) or which is cited to establish the publication date of another citation or other special reason (as specified) *O* document referring to an oral disclosure, use, exhibition or other means *P* document published prior to the international filing date but later than the priority date claimed	*T* later document published after the international filing date or priority date and not in conflict with the application but cited to understand the principle or theory underlying the invention *X* document of particular relevance; the claimed invention cannot be considered novel or cannot be considered to involve an inventive step when the document is taken alone *Y* document of particular relevance; the claimed invention cannot be considered to involve an inventive step when the document is combined with one or more other such documents, such combination being obvious to a person skilled in the art. *&* document member of the same patent family			
Date of the actual completion of the international search  19 January 1998		Date of mailing of the international search report  28.01.98		
Name and mailing address of the ISA European Patent Office, P.B. 5818 Patentlaan 2 NL - 2280 HV Rijswijk Tel. (+31-70) 340-2040, Tx. 31 651 epo nl, Fax: (+31-70) 340-3016		Authorized officer  Breusing, J		

2

INTERNATIONAL SEARCH REPORT

International Application No  
PCT/US 97/18061

C.(Continuation) DOCUMENTS CONSIDERED TO BE RELEVANT		
Category °	Citation of document, with indication, where appropriate, of the relevant passages	Relevant to claim No.
A	WO 92 05456 A (ROWE DEINES INSTR INC) 2 April 1992 see page 2, line 14 - page 11, line 1 & US 5 483 499 A cited in the application ---	2,13,24, 39
A	US 5 530 683 A (LINDBERG JAN F) 25 June 1996 see abstract; figures 3,4 ---	1
A	EP 0 524 749 A (TOKYO SHIBAURA ELECTRIC CO) 27 January 1993 see column 4, line 54 - column 5, line 10; figures 1,4 see column 7, line 20 - column 8, line 15 ---	1,12,23, 35
A	WO 95 06885 A (THOMSON CSF ;PERENNES MARC (FR)) 9 March 1995 see page 1, line 19 - page 2, line 15; figures 1-6 ---	1
A	GB 2 053 475 A (PHILIPS NV) 4 February 1981 see abstract; figure 1 ---	4,15,26
A	EP 0 383 270 A (HITACHI LTD) 22 August 1990 see column 2, line 28 - column 3, line 9; figure 1 ---	1
A	EP 0 616 231 A (INST BIOMEDIZINISCHE TECHNIK) 21 September 1994 see abstract; figure 2 -----	

# INTERNATIONAL SEARCH REPORT

Information on patent family members

International Application No

PCT/US 97/18061

Patent document cited in search report	Publication date	Patent family member(s)	Publication date
US 5550792 A	27-08-96	NONE	
-----			
US 4641291 A	03-02-87	NONE	
-----			
WO 9205456 A	02-04-92	AU 652699 B	01-09-94
		AU 8758191 A	15-04-92
		CA 2092564 A	27-03-92
		DE 69126040 D	12-06-97
		DE 69126040 T	02-01-98
		EP 0573431 A	15-12-93
		JP 6503163 T	07-04-94
		US 5483499 A	09-01-96
		US RE35535 E	17-06-97
		US 5615173 A	25-03-97
		US 5208785 A	04-05-93
-----			
US 5530683 A	25-06-96	NONE	
-----			
EP 0524749 A	27-01-93	DE 69213600 D	17-10-96
		DE 69213600 T	27-02-97
		JP 5228142 A	07-09-93
		US 5327895 A	12-07-94
-----			
WO 9506885 A	09-03-95	FR 2709559 A	10-03-95
		CA 2169935 A	09-03-95
		DE 69402084 D	17-04-97
		DE 69402084 T	19-06-97
		EP 0716751 A	19-06-96
		US 5694372 A	02-12-97
-----			
GB 2053475 A	04-02-81	FR 2460489 A	23-01-81
		AU 537043 B	31-05-84
		AU 5976580 A	15-01-81
		BE 884155 A	05-01-81
		CA 1146662 A	17-05-83
		DE 3025168 A	08-01-81
		JP 1342741 C	14-10-86
		JP 56011374 A	04-02-81
		JP 61006348 B	25-02-86
		NL 8003770 A	06-01-81

## Electronic Patent Application Fee Transmittal

<b>Application Number:</b>	12460139
<b>Filing Date:</b>	14-Jul-2009
<b>Title of Invention:</b>	Downscan imaging sonar
<b>First Named Inventor/Applicant Name:</b>	Brian T. Maguire
<b>Filer:</b>	Michael D. McCoy/Judy Creel
<b>Attorney Docket Number:</b>	038495/369324

Filed as Large Entity

### Utility under 35 USC 111(a) Filing Fees

Description	Fee Code	Quantity	Amount	Sub-Total in USD(\$)
<b>Basic Filing:</b>				
<b>Pages:</b>				
<b>Claims:</b>				
<b>Miscellaneous-Filing:</b>				
<b>Petition:</b>				
<b>Patent-Appeals-and-Interference:</b>				
<b>Post-Allowance-and-Post-Issuance:</b>				
<b>Extension-of-Time:</b>				

Description	Fee Code	Quantity	Amount	Sub-Total in USD(\$)
<b>Miscellaneous:</b>				
Submission- Information Disclosure Stmt	1806	1	180	180
<b>Total in USD (\$)</b>				<b>180</b>

## Electronic Acknowledgement Receipt

<b>EFS ID:</b>	11407813
<b>Application Number:</b>	12460139
<b>International Application Number:</b>	
<b>Confirmation Number:</b>	9769
<b>Title of Invention:</b>	Downscan imaging sonar
<b>First Named Inventor/Applicant Name:</b>	Brian T. Maguire
<b>Customer Number:</b>	826
<b>Filer:</b>	Michael D. McCoy/Judy Creel
<b>Filer Authorized By:</b>	Michael D. McCoy
<b>Attorney Docket Number:</b>	038495/369324
<b>Receipt Date:</b>	15-NOV-2011
<b>Filing Date:</b>	14-JUL-2009
<b>Time Stamp:</b>	11:47:23
<b>Application Type:</b>	Utility under 35 USC 111(a)

### Payment information:

Submitted with Payment	yes
Payment Type	Deposit Account
Payment was successfully received in RAM	\$180
RAM confirmation Number	10365
Deposit Account	160605
Authorized User	

### File Listing:

Document Number	Document Description	File Name	File Size(Bytes)/ Message Digest	Multi Part /.zip	Pages (if appl.)
-----------------	----------------------	-----------	-------------------------------------	------------------	------------------

1		369324_IDS.PDF	1297118	yes	18
			4bfac3fe77b48730572fb0a38d7937619449a5d2		
<b>Multipart Description/PDF files in .zip description</b>					
		<b>Document Description</b>	<b>Start</b>	<b>End</b>	
		Transmittal Letter	1	2	
		Information Disclosure Statement (IDS) Form (SB08)	3	18	
<b>Warnings:</b>					
<b>Information:</b>					
2		369324_FOREIGN_REFS.PDF	4158489	yes	84
			2c78526d86117ee63ac9693084c45f9f2b714e		
<b>Multipart Description/PDF files in .zip description</b>					
		<b>Document Description</b>	<b>Start</b>	<b>End</b>	
		Foreign Reference	1	7	
		Foreign Reference	8	19	
		Foreign Reference	20	31	
		Foreign Reference	32	43	
		Foreign Reference	44	84	
<b>Warnings:</b>					
<b>Information:</b>					
3		369324_NPL_CITES_144_145.PDF	9693096	yes	164
			7ef857ccc72f08b1d1ac29ef4289958fd9e0414		
<b>Multipart Description/PDF files in .zip description</b>					
		<b>Document Description</b>	<b>Start</b>	<b>End</b>	
		Non Patent Literature	1	4	
		Non Patent Literature	5	164	
<b>Warnings:</b>					
<b>Information:</b>					
4		369324_NPL_CITES_146_154.PDF	16680013	yes	126 506 of 737
			3fcffe25401201b6851b9c62f847965933672afb		



<b>Multipart Description/PDF files in .zip description</b>			
<b>Document Description</b>	<b>Start</b>	<b>End</b>	
Non Patent Literature	1	15	
Non Patent Literature	16	21	
Non Patent Literature	22	31	
Non Patent Literature	32	60	
Non Patent Literature	61	74	
Non Patent Literature	75	79	
Non Patent Literature	80	90	
Non Patent Literature	91	98	
Non Patent Literature	99	126	

**Warnings:**

**Information:**

5		369324_NPL_CITES_155_166. PDF	8610354 <small>03d06215eccd8103dc498e8507848a9f991c4843</small>	yes	87
---	--	----------------------------------	--	-----	----

<b>Multipart Description/PDF files in .zip description</b>			
<b>Document Description</b>	<b>Start</b>	<b>End</b>	
Non Patent Literature	1	11	
Non Patent Literature	12	29	
Non Patent Literature	30	35	
Non Patent Literature	36	39	
Non Patent Literature	40	44	
Non Patent Literature	45	48	
Non Patent Literature	49	59	
Non Patent Literature	60	65	

	Non Patent Literature	66	73
	Non Patent Literature	74	75
	Non Patent Literature	76	81
	Non Patent Literature	82	87

**Warnings:**

**Information:**

6		369324_NPL_CITES_167_176. PDF	10230476 <small>c3b05d3ba35e55ccc1f510d677acdfc2493e062e</small>	yes	158
---	--	----------------------------------	---	-----	-----

**Multipart Description/PDF files in .zip description**

Document Description	Start	End
Non Patent Literature	1	11
Non Patent Literature	12	64
Non Patent Literature	65	70
Non Patent Literature	71	81
Non Patent Literature	82	86
Non Patent Literature	87	92
Non Patent Literature	93	97
Non Patent Literature	98	145
Non Patent Literature	146	152
Non Patent Literature	153	158

**Warnings:**

**Information:**

7		369324_NPL_CITES_177_179. PDF	13457115 <small>41452a17076223b6fd63fd1a0259bbe50c7563df</small>	yes	322
---	--	----------------------------------	---	-----	-----

**Multipart Description/PDF files in .zip description**

Document Description	Start	End

	Non Patent Literature	1	316
	Non Patent Literature	317	318
	Non Patent Literature	319	322

**Warnings:**

**Information:**

8		369324_NPL_CITES_180_189. PDF	17905592  15b1a760c6d0a77943210b51843978c04a330ec6	yes	217
---	--	----------------------------------	--	-----	-----

**Multipart Description/PDF files in .zip description**

Document Description	Start	End
Non Patent Literature	1	5
Non Patent Literature	6	10
Non Patent Literature	11	13
Non Patent Literature	14	17
Non Patent Literature	18	21
Non Patent Literature	22	24
Non Patent Literature	25	28
Non Patent Literature	29	107
Non Patent Literature	108	127
Non Patent Literature	128	217

**Warnings:**

**Information:**

9		369324_NPL_CITES_190_191. PDF	5087041  b01e8ec761e2e5370b6f5f14dd3fa787246e28e4	yes	162
---	--	----------------------------------	---	-----	-----

**Multipart Description/PDF files in .zip description**

Document Description	Start	End
Non Patent Literature	1	79

	Non Patent Literature		80		162
<b>Warnings:</b>					
<b>Information:</b>					
10		369324_NPL_CITES_192_193. PDF	7090736 <small>11cc36a462563197bec1fcc995a59ea00599537b</small>	yes	194
	<b>Multipart Description/PDF files in .zip description</b>				
	<b>Document Description</b>		<b>Start</b>	<b>End</b>	
	Non Patent Literature		1	102	
	Non Patent Literature		103	194	
<b>Warnings:</b>					
<b>Information:</b>					
11	Fee Worksheet (SB06)	fee-info.pdf	29873 <small>7dfaf1afbad57c9ad743e07f056fd358b8140ce5d</small>	no	2
<b>Warnings:</b>					
<b>Information:</b>					
<b>Total Files Size (in bytes):</b>			94239903		
<p><b>This Acknowledgement Receipt evidences receipt on the noted date by the USPTO of the indicated documents, characterized by the applicant, and including page counts, where applicable. It serves as evidence of receipt similar to a Post Card, as described in MPEP 503.</b></p> <p><b><u>New Applications Under 35 U.S.C. 111</u></b>  If a new application is being filed and the application includes the necessary components for a filing date (see 37 CFR 1.53(b)-(d) and MPEP 506), a Filing Receipt (37 CFR 1.54) will be issued in due course and the date shown on this Acknowledgement Receipt will establish the filing date of the application.</p> <p><b><u>National Stage of an International Application under 35 U.S.C. 371</u></b>  If a timely submission to enter the national stage of an international application is compliant with the conditions of 35 U.S.C. 371 and other applicable requirements a Form PCT/DO/EO/903 indicating acceptance of the application as a national stage submission under 35 U.S.C. 371 will be issued in addition to the Filing Receipt, in due course.</p> <p><b><u>New International Application Filed with the USPTO as a Receiving Office</u></b>  If a new international application is being filed and the international application includes the necessary components for an international filing date (see PCT Article 11 and MPEP 1810), a Notification of the International Application Number and of the International Filing Date (Form PCT/RO/105) will be issued in due course, subject to prescriptions concerning national security, and the date shown on this Acknowledgement Receipt will establish the international filing date of the application.</p>					

Attorney's Docket No. 038495/369324

PATENT

**IN THE UNITED STATES PATENT AND TRADEMARK OFFICE**

In re:	Brian T. Maguire	Confirmation No.:	9769
Appl. No.:	12/460,139	Art Unit:	3662
Filed:	July 14, 2009	Examiner:	HULKA, James R.
For:	DOWNSCAN IMAGING SONAR		

Mail Stop Amendment  
Commissioner for Patents  
P.O. Box 1450  
Alexandria, VA 22313-1450

**INFORMATION DISCLOSURE STATEMENT**

**CITATION UNDER 37 C.F.R. § 1.97**

Attached is a list of documents on form PTO-1449 along with a copy of any cited foreign patent documents and non-patent literature document in accordance with 37 CFR 1.98(a)(2). Also enclosed is a translation or a concise explanation of each non-English language document.

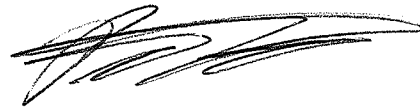
It is requested that the Examiner consider these documents and officially make them of record in accordance with the provisions of 37 C.F.R. § 1.97 and Section 609 of the MPEP. By identifying the listed documents, Applicant in no way makes any admission as to the prior art status of the listed documents, but is instead identifying the listed documents for the sake of full disclosure.

This Information Disclosure Statement is submitted in accordance with 37 C.F.R. § 1.97(c), before final Office Action or Allowance, whichever is earlier.

In re: Brian T. Maguire  
Appl. No.: 12/460,139  
Filed: July 14, 2009

The \$180.00 fee specified in 37 C.F.R. § 1.17(p) is being paid at the time of e-filing. The Commissioner is authorized to charge any additional fee, or credit any refund, to our Deposit Account No. 16-0605.

Respectfully submitted,



Patrick L. Kartes  
Registration No. 64,678

**Customer No. 00826**  
**ALSTON & BIRD LLP**  
Bank of America Plaza  
101 South Tryon Street, Suite 4000  
Charlotte, NC 28280-4000  
Tel Charlotte Office (704) 444-1000  
Fax Charlotte Office (704) 444-1111

**ELECTRONICALLY FILED USING THE EFS-WEB ELECTRONIC FILING SYSTEM OF THE UNITED STATES  
PATENT & TRADEMARK OFFICE ON NOVEMBER 15, 2011.**

## Electronic Acknowledgement Receipt

<b>EFS ID:</b>	11407979
<b>Application Number:</b>	12460139
<b>International Application Number:</b>	
<b>Confirmation Number:</b>	9769
<b>Title of Invention:</b>	Downscan imaging sonar
<b>First Named Inventor/Applicant Name:</b>	Brian T. Maguire
<b>Customer Number:</b>	826
<b>Filer:</b>	Michael D. McCoy/Judy Creel
<b>Filer Authorized By:</b>	Michael D. McCoy
<b>Attorney Docket Number:</b>	038495/369324
<b>Receipt Date:</b>	15-NOV-2011
<b>Filing Date:</b>	14-JUL-2009
<b>Time Stamp:</b>	11:59:41
<b>Application Type:</b>	Utility under 35 USC 111(a)

### Payment information:

Submitted with Payment	no
------------------------	----

### File Listing:

Document Number	Document Description	File Name	File Size(Bytes)/ Message Digest	Multi Part /.zip	Pages (if appl.)
1		369324_NPL_CITES_194_198. PDF	20295920 <small>2b91be281ab287cb339ef5af4a310ac0aac58cf</small>	yes	285

Multipart Description/PDF files in .zip description			
Document Description	Start	End	
Non Patent Literature	1	16	
Non Patent Literature	17	18	
Non Patent Literature	19	79	
Non Patent Literature	80	89	
Non Patent Literature	90	285	

**Warnings:**

**Information:**

2		369324_NPL_CITES_199_205. PDF	15131138 <small>970dd93f761515200db97eachbd6bcd78b004f96d</small>	yes	261
---	--	----------------------------------	--	-----	-----

Multipart Description/PDF files in .zip description			
Document Description	Start	End	
Non Patent Literature	1	43	
Non Patent Literature	44	127	
Non Patent Literature	128	147	
Non Patent Literature	148	152	
Non Patent Literature	153	176	
Non Patent Literature	177	186	
Non Patent Literature	187	261	

**Warnings:**

**Information:**

3		369324_NPL_CITES_206_213. PDF	22796785 <small>cc17e28b412e81dcb5fb35fbb8a95963aab687c</small>	yes	252
---	--	----------------------------------	--	-----	-----

Multipart Description/PDF files in .zip description			
Document Description	Start	End	
Non Patent Literature	1	4	



	Non Patent Literature	5	32
	Non Patent Literature	33	48
	Non Patent Literature	49	52
	Non Patent Literature	53	54
	Non Patent Literature	55	77
	Non Patent Literature	78	165
	Non Patent Literature	166	252

**Warnings:**

**Information:**

**Total Files Size (in bytes):**

58223843

**This Acknowledgement Receipt evidences receipt on the noted date by the USPTO of the indicated documents, characterized by the applicant, and including page counts, where applicable. It serves as evidence of receipt similar to a Post Card, as described in MPEP 503.**

**New Applications Under 35 U.S.C. 111**

**If a new application is being filed and the application includes the necessary components for a filing date (see 37 CFR 1.53(b)-(d) and MPEP 506), a Filing Receipt (37 CFR 1.54) will be issued in due course and the date shown on this Acknowledgement Receipt will establish the filing date of the application.**

**National Stage of an International Application under 35 U.S.C. 371**

**If a timely submission to enter the national stage of an international application is compliant with the conditions of 35 U.S.C. 371 and other applicable requirements a Form PCT/DO/EO/903 indicating acceptance of the application as a national stage submission under 35 U.S.C. 371 will be issued in addition to the Filing Receipt, in due course.**

**New International Application Filed with the USPTO as a Receiving Office**

**If a new international application is being filed and the international application includes the necessary components for an international filing date (see PCT Article 11 and MPEP 1810), a Notification of the International Application Number and of the International Filing Date (Form PCT/RO/105) will be issued in due course, subject to prescriptions concerning national security, and the date shown on this Acknowledgement Receipt will establish the international filing date of the application.**

PATENT COOPERATION TREATY

LFM  
pull

From the INTERNATIONAL SEARCHING AUTHORITY

PCT

To:  
 Thorson, Chad L.  
 ALSTON & BIRD LLP  
 Bank of America Plaza  
 101 South Tryon Street, Suite 4000  
 Charlotte, NC 28280-4000  
 ETATS-UNIS D'AMERIQUE

*Alston & Bird*  
 OCT 12 2010  
 Received By 23

NOTIFICATION OF TRANSMITTAL OF  
 THE INTERNATIONAL SEARCH REPORT AND  
 THE WRITTEN OPINION OF THE INTERNATIONAL  
 SEARCHING AUTHORITY, OR THE DECLARATION

(PCT Rule 44.1)

Date of mailing (day/month/year)	11 October 2010 (11-10-2010)
Applicant's or agent's file reference 38495/388216	<b>FOR FURTHER ACTION</b> See paragraphs 1 and 4 below
International application No. PCT/US2010/039441	International filing date (day/month/year) 22 June 2010 (22-06-2010)
Applicant NAVICO, INC.	

1.  The applicant is hereby notified that the international search report and the written opinion of the International Searching Authority have been established and are transmitted herewith.

**Filing of amendments and statement under Article 19:**  
 The applicant is entitled, if he so wishes, to amend the claims of the International Application (see Rule 46):

**When?** The time limit for filing such amendments is normally two months from the date of transmittal of the International Search Report.

**Where?** Directly to the International Bureau of WIPO, 34 chemin des Colombettes  
 1211 Geneva 20, Switzerland, Facsimile No.: (41-22) 338.82.70

**For more detailed instructions, see the notes on the accompanying sheet.**

2.  The applicant is hereby notified that no international search report will be established and that the declaration under Article 17(2)(a) to that effect and the written opinion of the International Searching Authority are transmitted herewith.

3.  **With regard to any protest** against payment of (an) additional fee(s) under Rule 40.2, the applicant is notified that:

the protest together with the decision thereon has been transmitted to the International Bureau together with the applicant's request to forward the texts of both the protest and the decision thereon to the designated Offices.

no decision has been made yet on the protest; the applicant will be notified as soon as a decision is made.

4. **Reminders**


Shortly after the expiration of **18 months** from the priority date, the international application will be published by the International Bureau. If the applicant wishes to avoid or postpone publication, a notice of withdrawal of the international application, or of the priority claim, must reach the International Bureau as provided in Rules 90*bis*.1 and 90*bis*.3, respectively, before the completion of the technical preparations for international publication.

The applicant may submit comments on an informal basis on the written opinion of the International Searching Authority to the International Bureau. The International Bureau will send a copy of such comments to all designated Offices unless an international preliminary examination report has been or is to be established. These comments would also be made available to the public but not before the expiration of 30 months from the priority date.

Within **19 months** from the priority date, but only in respect of some designated Offices, a demand for international preliminary examination must be filed if the applicant wishes to postpone the entry into the national phase **until 30 months** from the priority date (in some Offices even later); otherwise, the applicant must, **within 20 months** from the priority date, perform the prescribed acts for entry into the national phase before those designated Offices.

In respect of other designated Offices, the time limit of **30 months** (or later) will apply even if no demand is filed within 19 months.

See the Annex to Form PCT/IB/301 and, for details about the applicable time limits, Office by Office, see the *PCT Applicant's Guide*, National Chapters.

Name and mailing address of the International Searching Authority  European Patent Office, P.B. 5818 Patentlaan 2 NL-2280 HV Rijswijk Tel. (+31-70) 340-2040 Fax: (+31-70) 340-3016	Authorized officer KUES, Saba Tel: +31 (0)70 340-1934	<b>DOCKETED</b> <b>DUE DATE</b> By <u>[Signature]</u> Date <u>10/12/10</u>
--	---	---

## NOTES TO FORM PCT/ISA/220

These Notes are intended to give the basic instructions concerning the filing of amendments under article 19. The Notes are based on the requirements of the Patent Cooperation Treaty, the Regulations and the Administrative Instructions under that Treaty. In case of discrepancy between these Notes and those requirements, the latter are applicable. For more detailed information, see also the *PCT Applicant's Guide*.

In these Notes, "Article", "Rule", and "Section" refer to the provisions of the PCT, the PCT Regulations and the PCT Administrative Instructions, respectively.

### INSTRUCTIONS CONCERNING AMENDMENTS UNDER ARTICLE 19

The applicant has, after having received the international search report and the written opinion of the International Searching Authority, one opportunity to amend the claims of the international application. It should however be emphasized that, since all parts of the international application (claims, description and drawings) may be amended during the international preliminary examination procedure, there is usually no need to file amendments of the claims under Article 19 except where, e.g. the applicant wants the latter to be published for the purposes of provisional protection or has another reason for amending the claims before international publication. Furthermore, it should be emphasized that provisional protection is available in some States only (see *PCT Applicant's Guide*, Annex B).

The attention of the applicant is drawn to the fact that amendments to the claims under Article 19 are not allowed where the International Searching Authority has declared, under Article 17(2), that no international search report would be established (see *PCT Applicant's Guide*, International Phase, paragraph 296).

#### What parts of the international application may be amended?

Under Article 19, only the claims may be amended.

During the international phase, the claims may also be amended (or further amended) under Article 34 before the International Preliminary Examining Authority. The description and drawings may only be amended under Article 34 before the International Examining Authority.

Upon entry into the national phase, all parts of the international application may be amended under Article 28 or, where applicable, Article 41.

#### When?

Within 2 months from the date of transmittal of the international search report or 16 months from the priority date, whichever time limit expires later. It should be noted, however, that the amendments will be considered as having been received on time if they are received by the International Bureau after the expiration of the applicable time limit but before the completion of the technical preparations for international publication (Rule 46.1).

#### Where not to file the amendments?

The amendments may only be filed with the International Bureau and not with the receiving Office or the International Searching Authority (Rule 46.2).

Where a demand for international preliminary examination has been/is filed, see below.

#### How?

Either by cancelling one or more entire claims, by adding one or more new claims or by amending the text of one or more of the claims as filed.

A replacement sheet or sheets containing a complete set of claims in replacement of all the claims previously filed must be submitted.

Where a claim is cancelled, no renumbering of the other claims is required. In all cases where claims are renumbered, they must be renumbered consecutively in Arabic numerals (Section 205(a)).

**The amendments must be made in the language in which the international application is to be published.**

#### What documents must/may accompany the amendments?

##### Letter (Section 205(b)):

The amendments must be submitted with a letter.

The letter will not be published with the international application and the amended claims. It should not be confused with the "Statement under Article 19(1)" (see below, under "Statement under Article 19(1)").

**The letter must be in English or French, at the choice of the applicant. However, if the language of the international application is English, the letter must be in English; if the language of the international application is French, the letter must be in French.**

## NOTES TO FORM PCT/ISA/220 (continued)

The letter must indicate the differences between the claims as filed and the claims as amended. It must, in particular, indicate, in connection with each claim appearing in the international application (it being understood that identical indications concerning several claims may be grouped), whether

- (i) the claim is unchanged;
- (ii) the claim is cancelled;
- (iii) the claim is new;
- (iv) the claim replaces one or more claims as filed;
- (v) the claim is the result of the division of a claim as filed.

**The following examples illustrate the manner in which amendments must be explained in the accompanying letter:**

1. [Where originally there were 48 claims and after amendment of some claims there are 51]:  
"Claims 1 to 29, 31, 32, 34, 35, 37 to 48 replaced by amended claims bearing the same numbers; claims 30, 33 and 36 unchanged; new claims 49 to 51 added."
2. [Where originally there were 15 claims and after amendment of all claims there are 11]:  
"Claims 1 to 15 replaced by amended claims 1 to 11."
3. [Where originally there were 14 claims and the amendments consist in cancelling some claims and in adding new claims]:  
"Claims 1 to 6 and 14 unchanged; claims 7 to 13 cancelled; new claims 15, 16 and 17 added."  
"Claims 7 to 13 cancelled; new claims 15, 16 and 17 added; all other claims unchanged."
4. [Where various kinds of amendments are made]:  
"Claims 1-10 unchanged; claims 11 to 13, 18 and 19 cancelled; claims 14, 15 and 16 replaced by amended claim 14; claim 17 subdivided into amended claims 15, 16 and 17; new claims 20 and 21 added."

### "Statement under article 19(1)" (Rule 46.4)

The amendments may be accompanied by a statement explaining the amendments and indicating any impact that such amendments might have on the description and the drawings (which cannot be amended under Article 19(1)).

The statement will be published with the international application and the amended claims.

**It must be in the language in which the international application is to be published.**

It must be brief, not exceeding 500 words if in English or if translated into English.

It should not be confused with and does not replace the letter indicating the differences between the claims as filed and as amended. It must be filed on a separate sheet and must be identified as such by a heading, preferably by using the words "Statement under Article 19(1)."

It may not contain any disparaging comments on the international search report or the relevance of citations contained in that report. Reference to citations, relevant to a given claim, contained in the international search report may be made only in connection with an amendment of that claim.

### **Consequence if a demand for international preliminary examination has already been filed**

If, at the time of filing any amendments and any accompanying statement, under Article 19, a demand for international preliminary examination has already been submitted, the applicant must preferably, at the time of filing the amendments (and any statement) with the International Bureau, also file with the International Preliminary Examining Authority a copy of such amendments (and of any statement) and, where required, a translation of such amendments for the procedure before that Authority (see Rules 55.3(a) and 62.2, first sentence). For further information, see the Notes to the demand form (PCT/IPEA/401).

If a demand for international preliminary examination is made, the written opinion of the International Searching Authority will, except in certain cases where the International Preliminary Examining Authority did not act as International Searching Authority and where it has notified the International Bureau under Rule 66.1bis(b), be considered to be a written opinion of the International Preliminary Examining Authority. If a demand is made, the applicant may submit to the International Preliminary Examining Authority a reply to the written opinion together, where appropriate, with amendments before the expiration of 3 months from the date of mailing of Form PCT/ISA/220 or before the expiration of 22 months from the priority date, whichever expires later (Rule 43bis.1(c)).

### **Consequence with regard to translation of the international application for entry into the national phase**

The applicant's attention is drawn to the fact that, upon entry into the national phase, a translation of the claims as amended under Article 19 may have to be furnished to the designated/elected Offices, instead of, or in addition to, the translation of the claims as filed.

For further details on the requirements of each designated/elected Office, see the *PCT Applicant's Guide*, National Chapters.

PATENT COOPERATION TREATY

PCT

INTERNATIONAL SEARCH REPORT

(PCT Article 18 and Rules 43 and 44)

Applicant's or agent's file reference 38495/388216	<b>FOR FURTHER ACTION</b>		see Form PCT/ISA/220 as well as, where applicable, item 5 below.
International application No. PCT/US2010/039441	International filing date (day/month/year) 22/06/2010	(Earliest) Priority Date (day/month/year) 14/07/2009	
Applicant  NAVICO, INC.			

This international search report has been prepared by this International Searching Authority and is transmitted to the applicant according to Article 18. A copy is being transmitted to the International Bureau.

This international search report consists of a total of 4 sheets.

It is also accompanied by a copy of each prior art document cited in this report.

1. Basis of the report

a. With regard to the **language**, the international search was carried out on the basis of:

- the international application in the language in which it was filed  
 a translation of the international application into \_\_\_\_\_, which is the language of a translation furnished for the purposes of international search (Rules 12.3(a) and 23.1(b))

b.  This international search report has been established taking into account the **rectification of an obvious mistake** authorized by or notified to this Authority under Rule 91 (Rule 43.6b/s(a)).

c.  With regard to any **nucleotide and/or amino acid sequence** disclosed in the international application, see Box No. I.

2.  **Certain claims were found unsearchable** (See Box No. II)

3.  **Unity of invention is lacking** (see Box No III)

4. With regard to the **title**,

- the text is approved as submitted by the applicant  
 the text has been established by this Authority to read as follows:

5. With regard to the **abstract**,

- the text is approved as submitted by the applicant  
 the text has been established, according to Rule 38.2(b), by this Authority as it appears in Box No. IV. The applicant may, within one month from the date of mailing of this international search report, submit comments to this Authority

6. With regard to the **drawings**,

- a. the figure of the **drawings** to be published with the abstract is Figure No. 9A  
 as suggested by the applicant  
 as selected by this Authority, because the applicant failed to suggest a figure  
 as selected by this Authority, because this figure better characterizes the invention
- b.  none of the figures is to be published with the abstract

INTERNATIONAL SEARCH REPORT

International application No  
PCT/US2010/039441

**A. CLASSIFICATION OF SUBJECT MATTER**  
INV. G01S15/87 G01S15/89  
ADD.  
According to International Patent Classification (IPC) or to both national classification and IPC

**B. FIELDS SEARCHED**  
Minimum documentation searched (classification system followed by classification symbols)  
G01S  
Documentation searched other than minimum documentation to the extent that such documents are included in the fields searched

Electronic data base consulted during the international search (name of data base and, where practical, search terms used)  
EPO-Internal

**C. DOCUMENTS CONSIDERED TO BE RELEVANT**

Category*	Citation of document, with indication, where appropriate, of the relevant passages	Relevant to claim No.
Y	US 5 991 239 A (FATEMI-BOOSHEHRI MOSTAFA [US] ET AL) 23 November 1999 (1999-11-23) figures 3,10 * abstract column 4, line 55 - line 58	1-73
Y	US 5 805 528 A (HAMADA TOKIHIKO [JP] ET AL) 8 September 1998 (1998-09-08) figures 9,10 * abstract	1-73
A	US 4 939 700 A (BRETON J RAYMOND [US]) 3 July 1990 (1990-07-03) figure 1 * abstract	1,39

Further documents are listed in the continuation of Box C.  See patent family annex.

\* Special categories of cited documents :  
 \*A\* document defining the general state of the art which is not considered to be of particular relevance  
 \*E\* earlier document but published on or after the international filing date  
 \*L\* document which may throw doubts on priority claim(s) or which is cited to establish the publication date of another citation or other special reason (as specified)  
 \*O\* document referring to an oral disclosure, use, exhibition or other means  
 \*P\* document published prior to the international filing date but later than the priority date claimed  
 \*T\* later document published after the international filing date or priority date and not in conflict with the application but cited to understand the principle or theory underlying the invention  
 \*X\* document of particular relevance; the claimed invention cannot be considered novel or cannot be considered to involve an inventive step when the document is taken alone  
 \*Y\* document of particular relevance; the claimed invention cannot be considered to involve an inventive step when the document is combined with one or more other such documents, such combination being obvious to a person skilled in the art.  
 \*&\* document member of the same patent family

Date of the actual completion of the international search <b>1 October 2010</b>	Date of mailing of the international search report <b>11/10/2010</b>
--	---

Name and mailing address of the ISA/ European Patent Office, P.B. 5818 Patentlaan 2 NL - 2280 HV Rijswijk Tel. (+31-70) 340-2040, Fax: (+31-70) 340-3016	Authorized officer  <b>Alberga, Vito</b>
--	--

## INTERNATIONAL SEARCH REPORT

International application No  
PCT/US2010/039441

C(Continuation). DOCUMENTS CONSIDERED TO BE RELEVANT		
Category*	Citation of document, with indication, where appropriate, of the relevant passages	Relevant to claim No.
A	US 2003/202426 A1 (ISHIHARA SHINJI [JP] ET AL) 30 October 2003 (2003-10-30) figure 5B * abstract  -----	1, 39

# INTERNATIONAL SEARCH REPORT

Information on patent family members

International application No <b>PCT/US2010/039441</b>
--

Patent document cited in search report	Publication date	Patent family member(s)	Publication date
US 5991239 A	23-11-1999	US 5903516 A	11-05-1999
US 5805528 A	08-09-1998	NONE	
US 4939700 A	03-07-1990	NONE	
US 2003202426 A1	30-10-2003	GB 2387907 A	29-10-2003
		JP 4033704 B2	16-01-2008
		JP 2003315453 A	06-11-2003



# PATENT COOPERATION TREATY

From the  
INTERNATIONAL SEARCHING AUTHORITY

# PCT

**WRITTEN OPINION OF THE  
INTERNATIONAL SEARCHING AUTHORITY  
(PCT Rule 43bis.1)**

To:

see form PCT/ISA/220

Date of mailing  
(day/month/year) see form PCT/ISA/210 (second sheet)

Applicant's or agent's file reference  
see form PCT/ISA/220

**FOR FURTHER ACTION**  
See paragraph 2 below

International application No.  
PCT/US2010/039441

International filing date (day/month/year)  
22.06.2010

Priority date (day/month/year)  
14.07.2009

International Patent Classification (IPC) or both national classification and IPC  
INV. G01S15/87 G01S15/89

Applicant  
NAVICO, INC.

1. This opinion contains indications relating to the following items:

- Box No. I Basis of the opinion
- Box No. II Priority
- Box No. III Non-establishment of opinion with regard to novelty, inventive step and industrial applicability
- Box No. IV Lack of unity of invention
- Box No. V Reasoned statement under Rule 43bis.1(a)(i) with regard to novelty, inventive step and industrial applicability; citations and explanations supporting such statement
- Box No. VI Certain documents cited
- Box No. VII Certain defects in the international application
- Box No. VIII Certain observations on the international application

2. **FURTHER ACTION**

If a demand for international preliminary examination is made, this opinion will usually be considered to be a written opinion of the International Preliminary Examining Authority ("IPEA") except that this does not apply where the applicant chooses an Authority other than this one to be the IPEA and the chosen IPEA has notified the International Bureau under Rule 66.1bis(b) that written opinions of this International Searching Authority will not be so considered.

If this opinion is, as provided above, considered to be a written opinion of the IPEA, the applicant is invited to submit to the IPEA a written reply together, where appropriate, with amendments, before the expiration of 3 months from the date of mailing of Form PCT/ISA/220 or before the expiration of 22 months from the priority date, whichever expires later.

For further options, see Form PCT/ISA/220.

3. For further details, see notes to Form PCT/ISA/220.

Name and mailing address of the ISA:



European Patent Office  
P.B. 5818 Patentlaan 2  
NL-2280 HV Rijswijk - Pays Bas  
Tel. +31 70 340 - 2040  
Fax: +31 70 340 - 3016

Date of completion of  
this opinion

see form  
PCT/ISA/210

Authorized Officer

Alberga, Vito

Telephone No. +31 70 340-2798



**WRITTEN OPINION OF THE  
INTERNATIONAL SEARCHING AUTHORITY**

International application No.  
PCT/US2010/039441

---

**Box No. I Basis of the opinion**

---

1. With regard to the **language**, this opinion has been established on the basis of:
  - the international application in the language in which it was filed
  - a translation of the international application into , which is the language of a translation furnished for the purposes of international search (Rules 12.3(a) and 23.1 (b)).
2.  This opinion has been established taking into account the **rectification of an obvious mistake** authorized by or notified to this Authority under Rule 91 (Rule 43bis.1(a))
3. With regard to any **nucleotide and/or amino acid sequence** disclosed in the international application, this opinion has been established on the basis of a sequence listing filed or furnished:
  - a. (means)
    - on paper
    - in electronic form
  - b. (time)
    - in the international application as filed
    - together with the international application in electronic form
    - subsequently to this Authority for the purposes of search
4.  In addition, in the case that more than one version or copy of a sequence listing has been filed or furnished, the required statements that the information in the subsequent or additional copies is identical to that in the application as filed or does not go beyond the application as filed, as appropriate, were furnished.
5. Additional comments:

---

**Box No. V Reasoned statement under Rule 43bis.1(a)(i) with regard to novelty, inventive step or industrial applicability; citations and explanations supporting such statement**

---

1. Statement

Novelty (N)	Yes: Claims	<u>1-73</u>
	No: Claims	
Inventive step (IS)	Yes: Claims	
	No: Claims	<u>1-73</u>
Industrial applicability (IA)	Yes: Claims	<u>1-73</u>
	No: Claims	

2. Citations and explanations

**see separate sheet**

---

**Box No. VII Certain defects in the international application**

---

The following defects in the form or contents of the international application have been noted:

**see separate sheet**

---

**Box No. VIII Certain observations on the international application**

---

The following observations on the clarity of the claims, description, and drawings or on the question whether the claims are fully supported by the description, are made:

**see separate sheet**

**Re Item V.**

1 References

Reference is made to the following documents:

D1 US 5 991 239 A (FATEMI-BOOSHEHRI MOSTAFA [US] ET AL)  
23 November 1999 (1999-11-23)

D2 US 5 805 528 A (HAMADA TOKIHIKO [JP] ET AL) 8 September  
1998 (1998-09-08)

2 Independent claims 1, 20 and 39

The present application does not meet the criteria of Article 33(1) PCT, because the subject-matter of claims 1, 20 and 39 does not involve an inventive step in the sense of Article 33(3) PCT.

2.1 Document D1 is regarded as being the closest prior art to the subject-matter of claim 1, and discloses (the references in parentheses applying to this document):

a method comprising:

- a) receiving first conical downscan sonar data from a circular downscan transducer (fig.3 and 10);
- b) receiving second downscan sonar data from a second downscan transducer (abs.);
- c) combining the conical downscan sonar data and the second downscan sonar data to produce combined downscan sonar data (abs.).

The subject-matter of claim 1 therefore differs from this known method in that the second downscan data are generated by a "*linear*" downscan transducer.

The problem to be solved by the present invention may therefore be regarded as:

how to improve the efficiency of a sonar imaging method.

A *linear*, or fan-shaped, beam is described in document D2 (see, e.g., fig.9 and 10) as providing the same advantages as in the present application. The skilled person would therefore regard it as a normal design option to include this feature in the method described in D1 in order to solve the problem posed.

Therefore, the subject-matter of independent claim 1 is not inventive in the sense of Article 33(3) PCT.

- 2.2 The subject-matter of claim 20 corresponds in terms of computer program features to that of claim 1. The objections raised in respect of claim 1, therefore, also apply, mutatis mutandis, to claim 20. For this reason, also claim 20 is not inventive within the meaning of Article 33(3) PCT.
- 2.3 The subject-matter of claim 39 corresponds in terms of apparatus features to that of claim 1. The objections raised in respect of claim 1, therefore, also apply, mutatis mutandis, to claim 39. For this reason, also claim 39 is not inventive within the meaning of Article 33(3) PCT.

3 Dependent claims 2-19, 21-38 and 40-73

Dependent claims 2-19, 21-38 and 40-73 do not appear to contain any additional features which, in combination with the features of any claim to which they refer, meet the requirements of the PCT in respect inventive step (Article 33(3) PCT).

**Re Item VII.**

4

- 4.1 Contrary to the requirements of Rule 5.1(a)(ii) PCT, the relevant background art disclosed in documents D1 and D2 is not mentioned in the description, nor are these documents identified therein.
- 4.2 Independent claims 1, 20 and 39 are not in the two-part form in accordance with Rule 6.3(b) PCT, which in the present case would be appropriate, with those features known in combination from the prior art (document D1) being placed in the preamble (Rule 6.3(b)(i) PCT) and with the remaining features being included in the characterising part (Rule 6.3(b)(ii) PCT).
- 4.3 The features of the claims are not provided with reference signs placed in parentheses (Rule 6.2(b) PCT).

**Re Item VIII.**

5

- 5.1 Claim 31, disclosing computer program features, is indicated as dependent on method claim 18.

Possible steps after receipt of the international search report (ISR) and written opinion of the International Searching Authority (WO-ISA)

---

General information

For all international applications filed on or after 01/01/2004 the competent ISA will establish an ISR. It is accompanied by the WO-ISA. Unlike the former written opinion of the IPEA (Rule 66.2 PCT), the WO-ISA is not meant to be responded to, but to be taken into consideration for further procedural steps. This document explains about the possibilities.

---

Amending claims under Art. 19 PCT

Within 2 months after the date of mailing of the ISR and the WO-ISA the applicant may file amended claims under Art. 19 PCT directly with the International Bureau of WIPO. The PCT reform of 2004 did not change this procedure. For further information please see Rule 46 PCT as well as form PCT/ISA/220 and the corresponding Notes to form PCT/ISA/220.

---

Filing a demand for international preliminary examination

In principle, the WO-ISA will be considered as the written opinion of the IPEA. This should, in many cases, make it unnecessary to file a demand for international preliminary examination. If the applicant nevertheless wishes to file a demand this must be done before expiry of 3 months after the date of mailing of the ISR/ WO-ISA or 22 months after priority date, whichever expires later (Rule 54bis PCT). Amendments under Art. 34 PCT can be filed with the IPEA as before, normally at the same time as filing the demand (Rule 66.1 (b) PCT).

If a demand for international preliminary examination is filed and no comments/amendments have been received the WO-ISA will be transformed by the IPEA into an IPRP (International Preliminary Report on Patentability) which would merely reflect the content of the WO-ISA. The demand can still be withdrawn (Art. 37 PCT).

---

Filing informal comments

After receipt of the ISR/WO-ISA the applicant may file informal comments on the WO-ISA directly with the International Bureau of WIPO. These will be communicated to the designated Offices together with the IPRP (International Preliminary Report on Patentability) at 30 months from the priority date. Please also refer to the next box.

---

End of the international phase

At the end of the international phase the International Bureau of WIPO will transform the WO-ISA or, if a demand was filed, the written opinion of the IPEA into the IPRP, which will then be transmitted together with possible informal comments to the designated Offices. The IPRP replaces the former IPER (international preliminary examination report).

---

Relevant PCT Rules and more information

Rule 43 PCT, Rule 43bis PCT, Rule 44 PCT, Rule 44bis PCT, PCT Newsletter 12/2003, OJ 11/2003, OJ 12/2003


PATENT COOPERATION TREATY

Alston & Bird

WF

OCT 12 2010

From the INTERNATIONAL SEARCHING AUTHORITY

PCT received By: 

NOTIFICATION OF TRANSMITTAL OF THE INTERNATIONAL SEARCH REPORT AND THE WRITTEN OPINION OF THE INTERNATIONAL SEARCHING AUTHORITY, OR THE DECLARATION

(PCT Rule 44.1)

To:  
 Thorson, Chad L.  
 ALSTON & BIRD LLP  
 Bank of America Plaza  
 101 South Tryon Street, Suite 4000  
 Charlotte, NC 28280-4000  
 ETATS-UNIS D'AMERIQUE

Date of mailing (day/month/year)	6 October 2010 (06-10-2010)
-------------------------------------	-----------------------------

Applicant's or agent's file reference 38495/388217
---


<b>FOR FURTHER ACTION</b>	See paragraphs 1 and 4 below
---------------------------	------------------------------

International application No. PCT/US2010/039443
--

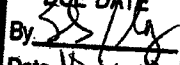
International filing date (day/month/year)	22 June 2010 (22-06-2010)
---	---------------------------

Applicant NAVICO, INC.
---------------------------

- The applicant is hereby notified that the international search report and the written opinion of the International Searching Authority have been established and are transmitted herewith.  
**Filing of amendments and statement under Article 19:**  
 The applicant is entitled, if he so wishes, to amend the claims of the International Application (see Rule 46):  
**When?** The time limit for filing such amendments is normally two months from the date of transmittal of the International Search Report.  
**Where?** Directly to the International Bureau of WIPO, 34 chemin des Colombettes  
 1211 Geneva 20, Switzerland, Facsimile No.: (41-22) 338.82.70  
**For more detailed instructions,** see the notes on the accompanying sheet.
- The applicant is hereby notified that no international search report will be established and that the declaration under Article 17(2)(a) to that effect and the written opinion of the International Searching Authority are transmitted herewith.
- With regard to any protest** against payment of (an) additional fee(s) under Rule 40.2, the applicant is notified that:
  - the protest together with the decision thereon has been transmitted to the International Bureau together with the applicant's request to forward the texts of both the protest and the decision thereon to the designated Offices.
  - no decision has been made yet on the protest; the applicant will be notified as soon as a decision is made.
- Reminders**  
 Shortly after the expiration of **18 months** from the priority date, the international application will be published by the International Bureau. If the applicant wishes to avoid or postpone publication, a notice of withdrawal of the international application, or of the priority claim, must reach the International Bureau as provided in Rules 90*bis*.1 and 90*bis*.3, respectively, before the completion of the technical preparations for international publication.  
 The applicant may submit comments on an informal basis on the written opinion of the International Searching Authority to the International Bureau. The International Bureau will send a copy of such comments to all designated Offices unless an international preliminary examination report has been or is to be established. These comments would also be made available to the public but not before the expiration of 30 months from the priority date.  
 Within **19 months** from the priority date, but only in respect of some designated Offices, a demand for international preliminary examination must be filed if the applicant wishes to postpone the entry into the national phase **until 30 months** from the priority date (in some Offices even later); otherwise, the applicant must, **within 20 months** from the priority date, perform the prescribed acts for entry into the national phase before those designated Offices.  
 In respect of other designated Offices, the time limit of **30 months** (or later) will apply even if no demand is filed within 19 months.  
 See the Annex to Form PCT/IB/301 and, for details about the applicable time limits, Office by Office, see the *PCT Applicant's Guide*, National Chapters.

Name and mailing address of the International Searching Authority  European Patent Office, P.B. 5818 Patentlaan 2 NL-2280 HV Rijswijk Tel. (+31-70) 340-2040 Fax: (+31-70) 340-3016
--

Authorized officer WALSH, Eric Tel: +31 (0)70 340-3813
--

DOCKETED  
 DUE DATE  
 By:   
 Date: 10-12-10

PATENT COOPERATION TREATY

PCT

INTERNATIONAL SEARCH REPORT

(PCT Article 18 and Rules 43 and 44)

Applicant's or agent's file reference 38495/388217	<b>FOR FURTHER ACTION</b> see Form PCT/ISA/220 as well as, where applicable, item 5 below.	
International application No. PCT/US2010/039443	International filing date (day/month/year) 22/06/2010	(Earliest) Priority Date (day/month/year) 14/07/2009
Applicant NAVICO, INC.		

This international search report has been prepared by this International Searching Authority and is transmitted to the applicant according to Article 18. A copy is being transmitted to the International Bureau.

This international search report consists of a total of 4 sheets.

It is also accompanied by a copy of each prior art document cited in this report.

1. Basis of the report

a. With regard to the **language**, the international search was carried out on the basis of:

- the international application in the language in which it was filed
- a translation of the international application into \_\_\_\_\_, which is the language of a translation furnished for the purposes of international search (Rules 12.3(a) and 23.1(b))

b.  This international search report has been established taking into account the **rectification of an obvious mistake** authorized by or notified to this Authority under Rule 91 (Rule 43.6bis(a)).

c.  With regard to any **nucleotide and/or amino acid sequence** disclosed in the international application, see Box No. I.

2.  **Certain claims were found unsearchable** (See Box No. II)

3.  **Unity of invention is lacking** (see Box No III)

4. With regard to the **title**,

- the text is approved as submitted by the applicant
- the text has been established by this Authority to read as follows:

5. With regard to the **abstract**,

- the text is approved as submitted by the applicant
- the text has been established, according to Rule 38.2(b), by this Authority as it appears in Box No. IV. The applicant may, within one month from the date of mailing of this international search report, submit comments to this Authority

6. With regard to the **drawings**,

- a. the figure of the **drawings** to be published with the abstract is Figure No. 8a
  - as suggested by the applicant
  - as selected by this Authority, because the applicant failed to suggest a figure
  - as selected by this Authority, because this figure better characterizes the invention
- b.  none of the figures is to be published with the abstract



**INTERNATIONAL SEARCH REPORT**

International application No  
PCT/US2010/039443

**A. CLASSIFICATION OF SUBJECT MATTER**  
 INV. G01S15/89 G01S15/96  
 ADD.

According to International Patent Classification (IPC) or to both national classification and IPC

**B. FIELDS SEARCHED**  
 Minimum documentation searched (classification system followed by classification symbols)  
 G01S

Documentation searched other than minimum documentation to the extent that such documents are included in the fields searched

Electronic data base consulted during the international search (name of data base and, where practical, search terms used)  
 EPO-Internal

**C. DOCUMENTS CONSIDERED TO BE RELEVANT**

Category*	Citation of document, with indication, where appropriate, of the relevant passages	Relevant to claim No.
Y	WO 98/15846 A1 (ROWE DEINES INSTR INC [US]) 16 April 1998 (1998-04-16) figures 3,4 * abstract page 7, line 32 claim 1	1-99
Y	US 3 618 006 A (WRIGHT CHARLES P) 2 November 1971 (1971-11-02) * abstract; figures 1,2	1-99
A	US 5 184 330 A (ADAMS JAMES W [US] ET AL) 2 February 1993 (1993-02-02) figures 4,5,6 * abstract	1

Further documents are listed in the continuation of Box C.       See patent family annex.

\* Special categories of cited documents :

\*A\* document defining the general state of the art which is not considered to be of particular relevance

\*E\* earlier document but published on or after the international filing date

\*L\* document which may throw doubts on priority claim(s) or which is cited to establish the publication date of another citation or other special reason (as specified)

\*O\* document referring to an oral disclosure, use, exhibition or other means

\*P\* document published prior to the international filing date but later than the priority date claimed

\*T\* later document published after the international filing date or priority date and not in conflict with the application but cited to understand the principle or theory underlying the invention

\*X\* document of particular relevance; the claimed invention cannot be considered novel or cannot be considered to involve an inventive step when the document is taken alone

\*Y\* document of particular relevance; the claimed invention cannot be considered to involve an inventive step when the document is combined with one or more other such documents, such combination being obvious to a person skilled in the art.

\*Z\* document member of the same patent family

Date of the actual completion of the international search	Date of mailing of the international search report
29 September 2010	06/10/2010

Name and mailing address of the ISA European Patent Office, P.B. 5818 Patentlaan 2 NL - 2280 HV Rijswijk Tel. (+31-70) 340-2040, Fax: (+31-70) 340-3016	Authorized officer  Alberga, Vito
---	---

1

INTERNATIONAL SEARCH REPORT

International application No  
PCT/US2010/039443

C(Continuation). DOCUMENTS CONSIDERED TO BE RELEVANT

Category*	Citation of document, with indication, where appropriate, of the relevant passages	Relevant to claim No.
A	US 4 879 697 A (LOWRANCE DARRELL J [US] ET AL) 7 November 1989 (1989-11-07) figure 4 * abstract -----	1
A	US 5 694 372 A (PERENNES MARC [FR]) 2 December 1997 (1997-12-02) figures 1,2 * abstract -----	1

**INTERNATIONAL SEARCH REPORT**

Information on patent family members

International application No

PCT/US2010/039443

Patent document cited in search report	Publication date	Patent family member(s)	Publication date
WO 9815846	A1	16-04-1998	AT 236409 T 15-04-2003
			DE 69720483 D1 08-05-2003
			DE 69720483 T2 24-12-2003
			EP 0929825 A1 21-07-1999
			JP 3995270 B2 24-10-2007
			JP 2001502058 T 13-02-2001
			JP 4087430 B2 21-05-2008
			JP 2007192830 A 02-08-2007
			NO 991555 A 04-06-1999
			US 5808967 A 15-09-1998
US 3618006	A	02-11-1971	NONE
US 5184330	A	02-02-1993	NONE
US 4879697	A	07-11-1989	NONE
US 5694372	A	02-12-1997	DE 69402084 D1 17-04-1997
			DE 69402084 T2 19-06-1997
			EP 0716751 A1 19-06-1996
			FR 2709559 A1 10-03-1995
			WO 9506885 A1 09-03-1995

# PATENT COOPERATION TREATY

From the  
INTERNATIONAL SEARCHING AUTHORITY

## PCT

**WRITTEN OPINION OF THE  
INTERNATIONAL SEARCHING AUTHORITY  
(PCT Rule 43bis.1)**

To:

see form PCT/ISA/220

Date of mailing  
(day/month/year) see form PCT/ISA/210 (second sheet)

Applicant's or agent's file reference  
see form PCT/ISA/220

**FOR FURTHER ACTION**  
See paragraph 2 below

International application No.  
PCT/US2010/039443

International filing date (day/month/year)  
22.06.2010

Priority date (day/month/year)  
14.07.2009

International Patent Classification (IPC) or both national classification and IPC  
INV. G01S15/89 G01S15/96

Applicant  
NAVICO, INC.

1. This opinion contains indications relating to the following items:

- Box No. I Basis of the opinion
- Box No. II Priority
- Box No. III Non-establishment of opinion with regard to novelty, inventive step and industrial applicability
- Box No. IV Lack of unity of invention
- Box No. V Reasoned statement under Rule 43bis.1(a)(i) with regard to novelty, inventive step and industrial applicability; citations and explanations supporting such statement
- Box No. VI Certain documents cited
- Box No. VII Certain defects in the international application
- Box No. VIII Certain observations on the international application

2. **FURTHER ACTION**


If a demand for international preliminary examination is made, this opinion will usually be considered to be a written opinion of the International Preliminary Examining Authority ("IPEA") except that this does not apply where the applicant chooses an Authority other than this one to be the IPEA and the chosen IPEA has notified the International Bureau under Rule 66.1bis(b) that written opinions of this International Searching Authority will not be so considered.

If this opinion is, as provided above, considered to be a written opinion of the IPEA, the applicant is invited to submit to the IPEA a written reply together, where appropriate, with amendments, before the expiration of 3 months from the date of mailing of Form PCT/ISA/220 or before the expiration of 22 months from the priority date, whichever expires later.

For further options, see Form PCT/ISA/220.

3. For further details, see notes to Form PCT/ISA/220.

Name and mailing address of the ISA:



European Patent Office  
P.B. 5818 Patentlaan 2  
NL-2280 HV Rijswijk - Pays Bas  
Tel. +31 70 340 - 2040  
Fax: +31 70 340 - 3016


Date of completion of this opinion

see form  
PCT/ISA/210

Authorized Officer

Alberga, Vito

Telephone No. +31 70 340-2798



**WRITTEN OPINION OF THE  
INTERNATIONAL SEARCHING AUTHORITY**

International application No.  
PCT/US2010/039443

---

**Box No. I Basis of the opinion**

---

1. With regard to the **language**, this opinion has been established on the basis of:
  - the international application in the language in which it was filed
  - a translation of the international application into , which is the language of a translation furnished for the purposes of international search (Rules 12.3(a) and 23.1 (b)).
2.  This opinion has been established taking into account the **rectification of an obvious mistake** authorized by or notified to this Authority under Rule 91 (Rule 43bis.1(a))
3. With regard to any **nucleotide and/or amino acid sequence** disclosed in the international application, this opinion has been established on the basis of a sequence listing filed or furnished:
  - a. (means)
    - on paper
    - in electronic form
  - b. (time)
    - in the international application as filed
    - together with the international application in electronic form
    - subsequently to this Authority for the purposes of search
4.  In addition, in the case that more than one version or copy of a sequence listing has been filed or furnished, the required statements that the information in the subsequent or additional copies is identical to that in the application as filed or does not go beyond the application as filed, as appropriate, were furnished.
5. Additional comments:

---

**Box No. V Reasoned statement under Rule 43bis.1(a)(i) with regard to novelty, inventive step or industrial applicability; citations and explanations supporting such statement**

---

1. Statement

Novelty (N)	Yes: Claims	<u>1-99</u>
	No: Claims	
Inventive step (IS)	Yes: Claims	
	No: Claims	<u>1-99</u>
Industrial applicability (IA)	Yes: Claims	<u>1-99</u>
	No: Claims	

2. Citations and explanations

see separate sheet

**WRITTEN OPINION OF THE  
INTERNATIONAL SEARCHING AUTHORITY**

International application No.  
PCT/US2010/039443

---

---

**Box No. VII Certain defects in the international application**

---

The following defects in the form or contents of the international application have been noted:

see separate sheet

---

**Box No. VIII Certain observations on the international application**

---

The following observations on the clarity of the claims, description, and drawings or on the question whether the claims are fully supported by the description, are made:

see separate sheet

**Re Item V.**

**1 References**

Reference is made to the following documents:

- D1 WO 98/15846 A1 (ROWE DEINES INSTR INC [US]) 16 April 1998  
(1998-04-16)
- D2 US 3 618 006 A (WRIGHT CHARLES P) 2 November 1971  
(1971-11-02)
- D3 US 5 184 330 A (ADAMS JAMES W [US] ET AL) 2 February 1993  
(1993-02-02)
- D4 US 4 879 697 A (LOWRANCE DARRELL J [US] ET AL) 7  
November 1989 (1989-11-07)
- D5 US 5 694 372 A (PERENNES MARC [FR]) 2 December 1997  
(1997-12-02)

**2 Independent claims 1, 32, 57 and 76**

Further to a lack of clarity discussed below, the present application does not meet the criteria of Article 33(1) PCT, because the subject-matter of claims 1, 32, 57 and 76 does not involve an inventive step in the sense of Article 33(3) PCT.

**2.1 The document D1 is regarded as being the closest prior art to the subject-matter of claim 1, and insofar as this claim can be understood, this document shows the following features thereof (the references in parentheses applying to this document):**

a transducer array (abs.) comprising:

a plurality of transducer elements (fig.3), each one of the plurality of transducer elements having a substantially rectangular shape (pag. 7, l.32) configured to produce a sonar beam having a beamwidth in a direction parallel to longitudinal length of the transducer elements that is significantly less than a beamwidth of the sonar beam in a direction perpendicular to the longitudinal length of the transducer elements (fig.3 and 4), wherein the plurality of transducer elements are positioned such that longitudinal lengths of at least two of the

plurality of transducer elements are substantially parallel to each other (fig.4), and wherein the plurality of transducer elements include at least:

- i) a first linear transducer element to project sonar pulses in a first direction (fig.3),
- ii) a second linear transducer element positioned to lie substantially in a plane with the first linear transducer element and to project sonar pulses in a second direction that is generally opposite of the first side (fig.3), and
- iii) a third linear transducer element positioned to project sonar pulses in a direction substantially perpendicular to the plane (fig.3).

The subject-matter of claim 1 therefore differs from this known system in that the transducer elements are positioned within a housing.

The problem to be solved by the present invention may therefore be regarded as:

how to conveniently arrange the transducer elements of an array.

A housing is described in document D2 (see, e.g., fig.1) as providing the same advantages as in the present application. The skilled person would therefore regard it as a normal design option to include this feature in the system described in D1 in order to solve the problem posed.

Therefore, the subject-matter of independent claim 1 is not inventive in the sense of Article 33(3) PCT.

2.2 Claims 32, 57 and 76 appear to be just reformulations of claim 1. The objections raised in respect of this claim also apply, *mutatis mutandis*, to claims 32, 57 and 76. The subject-matter of independent claims 32, 57 and 76 is therefore not inventive (Article 33(3) PCT).

3 Dependent claims 2-31, 33-56, 58-75 and 77-99

3.1 Claims 2-31, 33-56, 58-75 and 77-99 are dependent on claims 1, 32, 57 and 76, respectively, and as such also do not meet the requirements of PCT with respect to inventive step (Article 33(3) PCT).

#### **Re Item VII.**



- 4
- 4.1 Contrary to the requirements of Rule 5.1(a)(ii) PCT, the relevant background art disclosed in documents D1, D2, D3, D4 and D5 is not mentioned in the description, nor are these documents identified therein.
- 4.2 Independent claims 1, 32, 57 and 76 are not in the two-part form in accordance with Rule 6.3(b) PCT, which in the present case would be appropriate, with those features known in combination from the prior art (document D1) being placed in the preamble (Rule 6.3(b)(I) PCT) and with the remaining features being included in the characterising part (Rule 6.3(b)(ii) PCT).
- 4.3 The features of the claims are not provided with reference signs placed in parentheses (Rule 6.2(b) PCT).

**Re Item VIII.**

- 5
- 5.1 Although claims 1, 32, 57 and 76 have been drafted as separate independent claims, they appear to relate effectively to the same subject-matter and to differ from each other only with regard to the definition of the subject-matter for which protection is sought and in respect of the terminology used for the features of that subject-matter. The aforementioned claims therefore lack conciseness and as such do not meet the requirements of Article 6 PCT.
- 5.2 Terms like "substantially", "significantly", "generally" used, e.g., in claim 1 and in several other claims, are unclear and leave the reader in doubt as to the meaning of the technical features to which they refer, thereby rendering the definition of the subject-matter of said claims unclear (Article 6 PCT).

## Electronic Acknowledgement Receipt

<b>EFS ID:</b>	11408212
<b>Application Number:</b>	12460139
<b>International Application Number:</b>	
<b>Confirmation Number:</b>	9769
<b>Title of Invention:</b>	Downscan imaging sonar
<b>First Named Inventor/Applicant Name:</b>	Brian T. Maguire
<b>Customer Number:</b>	826
<b>Filer:</b>	Michael D. McCoy/Judy Creel
<b>Filer Authorized By:</b>	Michael D. McCoy
<b>Attorney Docket Number:</b>	038495/369324
<b>Receipt Date:</b>	15-NOV-2011
<b>Filing Date:</b>	14-JUL-2009
<b>Time Stamp:</b>	12:19:56
<b>Application Type:</b>	Utility under 35 USC 111(a)

### Payment information:

Submitted with Payment	no
------------------------	----

### File Listing:

Document Number	Document Description	File Name	File Size(Bytes)/ Message Digest	Multi Part /.zip	Pages (if appl.)
1	Non Patent Literature	369324_NPL_CITE_214.PDF	4845924 <small>afdeddcae74578f2c333db6a77a491102eeecba4</small>	no	88

### Warnings:

RAY-1002

### Information:

540 of 737

2	Non Patent Literature	369324_NPL_CITE_215.PDF	4565876 019b58ae6e9f5121b389db446c111fc6f2ae56cc	no	45
<b>Warnings:</b>					
<b>Information:</b>					
3	Non Patent Literature	369324_NPL_CITE_216.pdf	6231817 546add633538d85b36a8dc8f049a04879c14b7b2	no	24
<b>Warnings:</b>					
<b>Information:</b>					
4	Non Patent Literature	369324_NPL_217.PDF	3036355 f8560a38adde4eda37b9ec148768168f53123d5e	no	69
<b>Warnings:</b>					
<b>Information:</b>					
5		369324_NPL_CITES_218_223.PDF	5588131 f9c5a2b0a9a7d2ab4fffa79057e07c218ab87dd6	yes	107
<b>Multipart Description/PDF files in .zip description</b>					
		<b>Document Description</b>	<b>Start</b>	<b>End</b>	
		Non Patent Literature	1	5	
		Non Patent Literature	6	41	
		Non Patent Literature	42	59	
		Non Patent Literature	60	61	
		Non Patent Literature	62	63	
		Non Patent Literature	64	107	
<b>Warnings:</b>					
<b>Information:</b>					
6	Non Patent Literature	369324_NPL_CITE_224.PDF	1763406 5a9eda3b2868901d14caec434429f943dec44d91	no	38
<b>Warnings:</b>					
<b>Information:</b>					
7		369324_NPL_CITES_225_232.PDF	10688625 3e2dfa15217fd2fb7b052f5d39904272be89d644	yes	164

<b>Multipart Description/PDF files in .zip description</b>			
<b>Document Description</b>	<b>Start</b>	<b>End</b>	
Non Patent Literature	1	38	
Non Patent Literature	39	76	
Non Patent Literature	77	108	
Non Patent Literature	109	141	
Non Patent Literature	142	145	
Non Patent Literature	146	146	
Non Patent Literature	147	153	
Non Patent Literature	154	164	

**Warnings:**

**Information:**

8		369324_NPL_CITES_233_242. PDF	11916371 <small>26e90a91f9519646c8c67cf873f3217cf92fd 2cb</small>	yes	177
---	--	----------------------------------	--	-----	-----

<b>Multipart Description/PDF files in .zip description</b>			
<b>Document Description</b>	<b>Start</b>	<b>End</b>	
Non Patent Literature	1	107	
Non Patent Literature	108	115	
Non Patent Literature	116	126	
Non Patent Literature	127	129	
Non Patent Literature	130	131	
Non Patent Literature	132	144	
Non Patent Literature	145	155	
Non Patent Literature	156	158	
Non Patent Literature	159	166	

	Non Patent Literature	167	177
--	-----------------------	-----	-----

**Warnings:**

**Information:**

<b>Total Files Size (in bytes):</b>	48636505
-------------------------------------	----------

**This Acknowledgement Receipt evidences receipt on the noted date by the USPTO of the indicated documents, characterized by the applicant, and including page counts, where applicable. It serves as evidence of receipt similar to a Post Card, as described in MPEP 503.**

**New Applications Under 35 U.S.C. 111**

**If a new application is being filed and the application includes the necessary components for a filing date (see 37 CFR 1.53(b)-(d) and MPEP 506), a Filing Receipt (37 CFR 1.54) will be issued in due course and the date shown on this Acknowledgement Receipt will establish the filing date of the application.**

**National Stage of an International Application under 35 U.S.C. 371**

**If a timely submission to enter the national stage of an international application is compliant with the conditions of 35 U.S.C. 371 and other applicable requirements a Form PCT/DO/EO/903 indicating acceptance of the application as a national stage submission under 35 U.S.C. 371 will be issued in addition to the Filing Receipt, in due course.**

**New International Application Filed with the USPTO as a Receiving Office**

**If a new international application is being filed and the international application includes the necessary components for an international filing date (see PCT Article 11 and MPEP 1810), a Notification of the International Application Number and of the International Filing Date (Form PCT/RO/105) will be issued in due course, subject to prescriptions concerning national security, and the date shown on this Acknowledgement Receipt will establish the international filing date of the application.**

## Electronic Acknowledgement Receipt

<b>EFS ID:</b>	11408352
<b>Application Number:</b>	12460139
<b>International Application Number:</b>	
<b>Confirmation Number:</b>	9769
<b>Title of Invention:</b>	Downscan imaging sonar
<b>First Named Inventor/Applicant Name:</b>	Brian T. Maguire
<b>Customer Number:</b>	826
<b>Filer:</b>	Michael D. McCoy/Judy Creel
<b>Filer Authorized By:</b>	Michael D. McCoy
<b>Attorney Docket Number:</b>	038495/369324
<b>Receipt Date:</b>	15-NOV-2011
<b>Filing Date:</b>	14-JUL-2009
<b>Time Stamp:</b>	12:29:53
<b>Application Type:</b>	Utility under 35 USC 111(a)

### Payment information:

Submitted with Payment	no
------------------------	----

### File Listing:

Document Number	Document Description	File Name	File Size(Bytes)/ Message Digest	Multi Part /.zip	Pages (if appl.)
1		369324_NPL_CITES_243_244. PDF	17394723  e2e503eceda8733beca4d4bd9f31e356fa3ac a3e4	yes	206

Multipart Description/PDF files in .zip description			
Document Description	Start	End	
Non Patent Literature	1	6	
Non Patent Literature	7	206	

**Warnings:**

**Information:**

2		369324_NPL_CITES_245_254. PDF	12270179  b052f1baf6dd36d4f4c4d25e71e6fcb59b4 17ff	yes	121
---	--	----------------------------------	---	-----	-----

Multipart Description/PDF files in .zip description			
Document Description	Start	End	
Non Patent Literature	1	1	
Non Patent Literature	2	19	
Non Patent Literature	20	38	
Non Patent Literature	39	60	
Non Patent Literature	61	62	
Non Patent Literature	63	106	
Non Patent Literature	107	110	
Non Patent Literature	111	112	
Non Patent Literature	113	115	
Non Patent Literature	116	121	

**Warnings:**

**Information:**

3		369324_NPL_CITES_255_266. PDF	6912952  72f710727cc98fc8f2acc23f41ad32ac1836f0 62	yes	91
---	--	----------------------------------	---	-----	----

Multipart Description/PDF files in .zip description			
Document Description	Start	End	
Non Patent Literature	1	6	

Non Patent Literature	7	25
Non Patent Literature	26	27
Non Patent Literature	28	28
Non Patent Literature	29	29
Non Patent Literature	30	30
Non Patent Literature	31	31
Non Patent Literature	32	32
Non Patent Literature	33	76
Non Patent Literature	77	79
Non Patent Literature	80	83
Non Patent Literature	84	91

**Warnings:**

**Information:**

**Total Files Size (in bytes):**

36577854

**This Acknowledgement Receipt evidences receipt on the noted date by the USPTO of the indicated documents, characterized by the applicant, and including page counts, where applicable. It serves as evidence of receipt similar to a Post Card, as described in MPEP 503.**

**New Applications Under 35 U.S.C. 111**

**If a new application is being filed and the application includes the necessary components for a filing date (see 37 CFR 1.53(b)-(d) and MPEP 506), a Filing Receipt (37 CFR 1.54) will be issued in due course and the date shown on this Acknowledgement Receipt will establish the filing date of the application.**

**National Stage of an International Application under 35 U.S.C. 371**

**If a timely submission to enter the national stage of an international application is compliant with the conditions of 35 U.S.C. 371 and other applicable requirements a Form PCT/DO/EO/903 indicating acceptance of the application as a national stage submission under 35 U.S.C. 371 will be issued in addition to the Filing Receipt, in due course.**

**New International Application Filed with the USPTO as a Receiving Office**

**If a new international application is being filed and the international application includes the necessary components for an international filing date (see PCT Article 11 and MPEP 1810), a Notification of the International Application Number and of the International Filing Date (Form PCT/RO/105) will be issued in due course, subject to prescriptions concerning national security, and the date shown on this Acknowledgement Receipt will establish the international filing date of the application.**





UNITED STATES PATENT AND TRADEMARK OFFICE

UNITED STATES DEPARTMENT OF COMMERCE
United States Patent and Trademark Office
Address: COMMISSIONER FOR PATENTS
P.O. Box 1450
Alexandria, Virginia 22313-1450
www.uspto.gov

Table with 5 columns: APPLICATION NO., FILING DATE, FIRST NAMED INVENTOR, ATTORNEY DOCKET NO., CONFIRMATION NO.
12/460,139 07/14/2009 Brian T. Maguire 038495/369324 9769

826 7590 09/22/2011
ALSTON & BIRD LLP
BANK OF AMERICA PLAZA
101 SOUTH TRYON STREET, SUITE 4000
CHARLOTTE, NC 28280-4000

EXAMINER

HULKA, JAMES R

ART UNIT PAPER NUMBER

3662

MAIL DATE DELIVERY MODE

09/22/2011

PAPER

Please find below and/or attached an Office communication concerning this application or proceeding.

The time period for reply, if any, is set in the attached communication.

<b>Office Action Summary</b>	<b>Application No.</b> 12/460,139	<b>Applicant(s)</b> MAGUIRE, BRIAN T.	
	<b>Examiner</b> JAMES HULKA	<b>Art Unit</b> 3662	

**-- The MAILING DATE of this communication appears on the cover sheet with the correspondence address --**

**Period for Reply**

A SHORTENED STATUTORY PERIOD FOR REPLY IS SET TO EXPIRE 3 MONTH(S) OR THIRTY (30) DAYS, WHICHEVER IS LONGER, FROM THE MAILING DATE OF THIS COMMUNICATION.

- Extensions of time may be available under the provisions of 37 CFR 1.136(a). In no event, however, may a reply be timely filed after SIX (6) MONTHS from the mailing date of this communication.
- If NO period for reply is specified above, the maximum statutory period will apply and will expire SIX (6) MONTHS from the mailing date of this communication.
- Failure to reply within the set or extended period for reply will, by statute, cause the application to become ABANDONED (35 U.S.C. § 133). Any reply received by the Office later than three months after the mailing date of this communication, even if timely filed, may reduce any earned patent term adjustment. See 37 CFR 1.704(b).

**Status**

- 1)  Responsive to communication(s) filed on 29 August 2011.
- 2a)  This action is **FINAL**.
- 2b)  This action is non-final.
- 3)  An election was made by the applicant in response to a restriction requirement set forth during the interview on \_\_\_\_\_; the restriction requirement and election have been incorporated into this action.
- 4)  Since this application is in condition for allowance except for formal matters, prosecution as to the merits is closed in accordance with the practice under *Ex parte Quayle*, 1935 C.D. 11, 453 O.G. 213.

**Disposition of Claims**

- 5)  Claim(s) 1-99 is/are pending in the application.
- 5a) Of the above claim(s) 1-56 is/are withdrawn from consideration.
- 6)  Claim(s) \_\_\_\_\_ is/are allowed.
- 7)  Claim(s) 57-99 is/are rejected.
- 8)  Claim(s) \_\_\_\_\_ is/are objected to.
- 9)  Claim(s) \_\_\_\_\_ are subject to restriction and/or election requirement.

**Application Papers**

- 10)  The specification is objected to by the Examiner.
- 11)  The drawing(s) filed on \_\_\_\_\_ is/are: a)  accepted or b)  objected to by the Examiner.  
Applicant may not request that any objection to the drawing(s) be held in abeyance. See 37 CFR 1.85(a).  
Replacement drawing sheet(s) including the correction is required if the drawing(s) is objected to. See 37 CFR 1.121(d).
- 12)  The oath or declaration is objected to by the Examiner. Note the attached Office Action or form PTO-152.

**Priority under 35 U.S.C. § 119**

- 13)  Acknowledgment is made of a claim for foreign priority under 35 U.S.C. § 119(a)-(d) or (f).  
a)  All    b)  Some \*    c)  None of:  
1.  Certified copies of the priority documents have been received.  
2.  Certified copies of the priority documents have been received in Application No. \_\_\_\_\_.  
3.  Copies of the certified copies of the priority documents have been received in this National Stage application from the International Bureau (PCT Rule 17.2(a)).  
\* See the attached detailed Office action for a list of the certified copies not received.

**Attachment(s)**

- 1)  Notice of References Cited (PTO-892)
- 2)  Notice of Draftperson's Patent Drawing Review (PTO-948)
- 3)  Information Disclosure Statement(s) (PTO/SB/08)  
Paper No(s)/Mail Date 20101028.
- 4)  Interview Summary (PTO-413)  
Paper No(s)/Mail Date. \_\_\_\_\_.
- 5)  Notice of Informal Patent Application
- 6)  Other: \_\_\_\_\_.

RAY-1002

## DETAILED ACTION

### *Election/Restrictions*

1. **Applicant's election *without* traverse of Species II, Claims 57-99**, in the reply filed on 29 August 2011 is acknowledged. **Claims 1-56 have been withdrawn** from further consideration pursuant to 37 CFR 1.142(b) as being drawn to a nonelected Species, there being no allowable generic or linking claim. Election was made **without** traverse in the reply filed on 29 August 2011.

### *Claim Rejections - 35 USC § 112*

2. The following is a quotation of the second paragraph of 35 U.S.C. 112:

The specification shall conclude with one or more claims particularly pointing out and distinctly claiming the subject matter which the applicant regards as his invention.

3. **Claims 59, 60, 62 and 72 are rejected under 35 U.S.C. 112, second paragraph, as being indefinite** for failing to particularly point out and distinctly claim the subject matter which applicant regards as the invention.

4. Regarding Claim 59, the phrase "about 455 kHz and 800 KHz" is indefinite. The examiner interprets frequencies within 50 KHz above or below each value to be about 455 KHz or about 800 KHz.

Regarding Claim 60, the phrases "about 0.8 degrees", "about 32 degrees", "about 1.4 degrees", and "about 56 degrees" are indefinite. The examiner interprets any angle between 0.3 and 1.3 degrees to be about 0.8 degrees. The examiner interprets any angle between 0.9 and 1.9 degrees to be about 1.4 degrees. The examiner

Art Unit: 3662

interprets any angle between 27 and 37 degrees to be about 32 degrees. The examiner interprets any angle between 51 and 61 degrees to be about 56 degrees.

Regarding Claim 62, the phrases "about 120 mm" and "about 3 mm" are indefinite. The examiner interprets any length between 100 mm and 140 mm to be about 120 mm. The examiner interprets any width between 2 mm and 4 mm to be about 3 mm.

Regarding Claim 72, the phrase "substantially perpendicular" is indefinite. The examiner interprets any angle between the center of the beams that is between 85 degrees and 95 degrees to be substantially perpendicular.

### ***Claim Rejections - 35 USC § 103***

5. The following is a quotation of 35 U.S.C. 103(a) which forms the basis for all obviousness rejections set forth in this Office action:

(a) A patent may not be obtained though the invention is not identically disclosed or described as set forth in section 102 of this title, if the differences between the subject matter sought to be patented and the prior art are such that the subject matter as a whole would have been obvious at the time the invention was made to a person having ordinary skill in the art to which said subject matter pertains. Patentability shall not be negated by the manner in which the invention was made.

**6. Claims 57, 61, 72, 75-76, 78-79, 94 and 97 are rejected under 35 U.S.C. 103(a) as being unpatentable over Nishimori (5,561,641) in view of Shah (2006/0002232).**

7. Regarding Claim 57, Nishimori teaches a transducer array comprising:, the linear transducer element having a substantially rectangular shape configured to produce a sonar beam having a beam width in a direction parallel to longitudinal length of the linear transducer element ... wherein the linear transducer element is positioned within

Art Unit: 3662

the housing to project sonar pulses in a direction substantially perpendicular to a plane corresponding to the surface [Col. 18 Lines 1-20]. Nishimori does not explicitly teach a housing mountable to a watercraft ... Shah teaches a housing mountable to a watercraft ... [0029]. It would have been obvious to modify the array of Nishimori with a housing mountable to a watercraft because it would allow the transducer to be transported without being damaged.

Regarding Claim 61, Nishimori does not teach communicating with a single transceiver. Shah teaches communicating with a single transceiver [0029]. It would have been obvious to modify the array of Nishimori to include communicating with a single transceiver to reduce equipment costs.

Regarding Claim 76, Nishimori teaches a linear transducer element positioned ..., the linear transducer element having a substantially rectangular shape configured to produce a sonar beam having a beam width in a direction parallel to longitudinal length of the linear transducer element that is significantly less than a beam width of the sonar beam in a direction perpendicular to the longitudinal length of the transducer element, wherein the linear transducer element is positioned to project sonar pulses in a direction substantially perpendicular to a plane corresponding to the surface of a body of water; a sonar module configured to enable operable communication with the transducer array, the sonar module including: a sonar signal processor [Col 12, Lines 30-45] to process sonar return signals received via the linear transducer element. Nishimori does not teach a housing ... or at least one transceiver configured to provide communication between the linear transducer element and the sonar signal processor. Shah teaches a

Art Unit: 3662

housing ... or at least one transceiver configured to provide communication between the linear transducer element and the sonar signal processor [0029]. It would have been obvious to modify the array of Nishimori with a housing because it would allow the transducer to be transported without being damaged, and the transceiver would allow for more efficient and faster processing of the location data.

Regarding Claims 72 and 94, Nishimori also teaches a circular transducer element ... [Col 18, Lines 1-20].

Regarding Claims 75 and 97, Nishimori also teaches sonar signal returns from the circular transducer element and linear transducer element provide generally simultaneous data [Col 22, Lines 5-15].

Regarding Claim 78, Nishimori also teaches a sonar module is provided within a separate housing [Fig. 18].

Regarding Claim 79, Nishimori also teaches at least one display unit ... [86 of Fig. 18].

**8. Claims 58, 65-71, 74, 80-81, 83, 88-93, 96, 98 and 99 are rejected under 35 U.S.C. 103(a) as being unpatentable over Nishimori (5,561,641) in view of Shah (2006/0002232) as applied to claims 57, 72, 76 and 94 above, and further in view of Zimmerman (2007/0025183).**

9. Regarding Claims 58 and 83, Nishimori does not explicitly teach a linear transducer element is configured to operate at a selected one of at least two selectable operating frequencies. Zimmerman teaches a linear transducer element is configured to

Art Unit: 3662

operate at a selected one of at least two selectable operating frequencies [0003]. It would have been obvious to modify the system of Nishimori to be able to detect different types of objects effectively.

Regarding Claim 65, Nishimori does not explicitly teach a beam width in the direction parallel to longitudinal length of the linear transducer element is less than about five percent as large as the beam width of the sonar beam in the direction perpendicular to the longitudinal length of the linear transducer element. Zimmerman teaches a beam width in the direction parallel to longitudinal length of the linear transducer element is less than about five percent as large ... [Fig. 3]. It would have been obvious to modify the system of Nishimori to include a narrow beam in one direction to increase resolution of successive 2-D images.

Regarding Claims 66, 67 and 88, Nishimori does not explicitly teach images corresponding to data received via the linear transducer provide data regarding bottom features over less than fifty (or twenty) percent of a display screen when displayed. Zimmerman teaches images corresponding to data received via the linear transducer provide data regarding bottom features over less than fifty (or twenty) percent of a display screen when displayed [Claim 9]. It would have been obvious to modify the system of Nishimori to include display of images on less than fifty or twenty percent of a display screen to be able to see multiple images at one time, or to analyze a time series of data.

Regarding Claims 68-70, 89-91 and 93, Nishimori does not explicitly teach images of sonar data ... representing bottom data, depth data, water column data, or

Art Unit: 3662

data below the linear transducer element. Zimmerman teaches images of sonar data corresponding to data received via the linear transducer element representing bottom data, depth, data water column data, or data below the linear transducer element [0063-0065]. It would have been obvious to modify the system of Nishimori to include providing images with depth data, water bottom data, depth data, or data from vertically below the element in order to notify the operators of any physical obstacles or hazards.

Regarding Claims 71 and 92, Nishimori does not explicitly teach sonar data images of two or more of ... Zimmerman teaches sonar data images of two or more of ... [0063-0065]. It would have been obvious to modify the system of Nishimori to include providing images or two or more of depth data, water bottom data, or depth data in order to notify the operators of any physical obstacles or hazards.

Regarding Claims 74 and 96, Nishimori does not teach linear transducer and circular transducer elements are positioned to project fan-shaped and conical sonar beams ... to sonify areas of the bottom that at least partially overlap. Zimmerman teaches linear transducer and circular transducer elements are positioned to project fan-shaped and conical sonar beams ... to sonify areas of the bottom that at least partially overlap [0027]. It would have been obvious to modify the system of Nishimori to include overlapping circular and linear transducer beams to improve sonar image resolution.

Regarding Claim 80, Nishimori does not explicitly teach a display and the sonar module are in the same housing. Zimmerman teaches a display and the sonar module are in the same housing [Fig. 4a]. It would have been obvious to modify the system of



Art Unit: 3662

Nishimori to put both items in the same housing to reduce the number of pieces of equipment on board the vessel.

Regarding Claim 81, Nishimori does not explicitly teach at least one display of the plurality of displays is enabled to simultaneously provide different images... Zimmerman teaches at least one display of the plurality of displays is enabled to simultaneously provide different images... [Claim 9]. It would have been obvious to modify the system of Nishimori to include display of different images simultaneously to be able to see multiple images at one time, or to analyze a time series of data.

Regarding Claim 98, Nishimori does not explicitly teach data from at least one of the group of radar, GPS, digital mapping, time and temperature. Zimmerman teaches data from at least one of the group of radar, GPS, digital mapping, time and temperature [0023, 0064]. It would have been obvious to modify the system of Nishimori to include data from at least one of those resources to improve location tracking of desired underwater targets.

Regarding Claim 99, Nishimori does not explicitly teach display of the data is in a user-selectable format. Zimmerman teaches display of the data is in a user-selectable format [0064-065]. It would have been obvious to modify the system of Nishimori to include a user selectable display format screen to be able to see multiple images at one time, or to analyze a time series of data.

Art Unit: 3662

**10. Claims 64, 73, 77, 85, 87 and 95 are rejected under 35 U.S.C. 103(a) as being unpatentable over Nishimori (5,561,641) in view of Shah (2006/0002232) as applied to claims 57, 72 and 76 above, and further in view of Thompson (7,542,376).**

11. Regarding Claim 64, Nishimori does not teach a housing has a streamlined shape. Thompson teaches a housing has a streamlined shape [Col. 2, Lines 35-55]. It would have been obvious to modify the system of Nishimori to include a streamlined housing in order to protect the contents of the system from being damaged.

Regarding Claims 73 and 95, Nishimori does not explicitly teach linear and circular transducer elements are in the same housing or that the circular transducer element produces a conical downscan beam from within the same housing. Thompson teaches linear and circular transducer elements are in the same housing or that the circular transducer element produces a conical downscan beam from within the same housing [Col. 2, Lines 35-55]. It would have been obvious to modify the system of Nishimori to include putting both transducers in the same housing to reduce material cost.

Regarding Claim 77, Nishimori does not explicitly teach an Ethernet hub ... Thompson teaches an Ethernet Hub ... [Col. 6, Lines 10-15]. It would have been obvious to modify the system of Nishimori to include an Ethernet hub to allow multiple users to analyze the sonar data and images, or to increase the speed of data transfer.

Regarding Claims 85 and 87, Nishimori does not explicitly teach a housing being mountable to a watercraft ... capable of traversing a surface of a body of water. Thompson teaches a housing being mountable to a watercraft ... capable of traversing

Art Unit: 3662

a surface of a body of water [Col. 2 Lines 30-45]. It would have been obvious to modify the system of Nishimori to include mounting a housing to a watercraft in order to examine different areas of a body of water more efficiently.

**12. Claim 60 is rejected under 35 U.S.C. 103(a) as being unpatentable over Nishimori (5,561,641) in view of Shah (2006/0002232) as applied to claim 57 above, and further in view of Audi (5,438,552).**

**13.** Regarding Claim 60, Nishimori does not teach a beam width of a linear transducer element is about 0.8 degrees by about 32 degrees or about 1.4 degrees by about 56 degrees. Audi teaches a beam width of a linear transducer element is about 0.8 degrees by about 32 degrees or about 1.4 degrees by about 56 degrees [Col. 1, Lines 15-35]. It would have been obvious to modify the system of Nishimori to produce a wide, thin beam to cover a large area while also producing higher resolution sonar images.

**14. Claim 62 is rejected under 35 U.S.C. 103(a) as being unpatentable over Nishimori (5,561,641) in view of Shah (2006/0002232) as applied to claim 57 above, and further in view of Blue (5,850,372) and Bird (4,774,837).**

**15.** Regarding Claim 62, Nishimori does not teach a length of a rectangular face of the linear transducer element is about 120 mm and a width of the rectangular face of the linear transducer element is about 3 mm. Blue [Col 6, Lines 1-5] and Bird [Col 2. Lines 40-60] teach a length of a rectangular face of the linear transducer element is

Art Unit: 3662

about 120 mm and a width of the rectangular face of the linear transducer element is about 3 mm. It would have been obvious to modify the system of Nishimori to make a specific size transducer to produce a beam for desired applications and also to eliminate unnecessary costs.

**16. Claims 59 and 84 are rejected under 35 U.S.C. 103(a) as being unpatentable over Nishimori (5,561,641) in view of Shah (2006/0002232) as applied to claims 57 and 76 above, and further in view of Zimmerman (2007/0025183), Richard (4,538,249) and Adams (5,184,330).**

17. Regarding Claim 59, Nishimori does not explicitly teach selectable operating frequencies include about 455 kHz and 800 KHz. Zimmerman [0003], Adams [Col. 5, Lines 1-5], and Richard [Col. 8, Lines 45-60]. It would have been obvious to modify the system of Nishimori to include specific frequencies depending on the types of objects being tracked by the sonar in the water.

**18. Claim 82 is rejected under 35 U.S.C. 103(a) as being unpatentable over Nishimori (5,561,641) in view of Shah (2006/0002232) as applied to claim 76 above, and further in view of Wilcox (5,142,502).**

19. Regarding Claim 82, Nishimori does not explicitly teach configuration settings defining a predefined set of display images ... Wilcox teaches configuration settings defining a predefined set of display images ... [Col. 3, Lines 50-70]. It would have been

Art Unit: 3662

obvious to modify the system of Nishimori to include configuration settings to allow the user to compare different sonar images taken during different surveys.

**20. Claims 63 and 86 are rejected under 35 U.S.C. 103(a) as being unpatentable over Nishimori (5,561,641) in view of Shah (2006/0002232) as applied to claims 57, 76, and 85 above, further in view of Thompson (7,542,376) and Zimmerman (2007/0025183).**

21. Regarding Claims 63 and 86, Nishimori does not teach a housing is mountable to a vessel to generate sonar pulses defining a fan-shaped beam extending from one side of the vessel to an opposite side of the vessel. Nishimori does not explicitly teach a housing mountable to a watercraft ... Thompson teaches a housing mountable to a watercraft ... [Col. 2 Lines 35-55]. It would have been obvious to modify the array of Nishimori with a housing mountable to a watercraft because it would allow the transducer to be transported without being damaged. Zimmerman teaches a fan-shaped beam ... [Fig 3]. It would have been obvious to modify the system of Nishimori to include a fan-shaped beam to identify objects in a larger area near the vessel.

### ***Conclusion***

Any inquiry concerning this communication or earlier communications from the examiner should be directed to JAMES HULKA whose telephone number is (571)270-7553. The examiner can normally be reached on Monday thru Thursday 7:30am-5pm, Every 2nd Friday, 7:30am - 4pm.

Art Unit: 3662

If attempts to reach the examiner by telephone are unsuccessful, the examiner's supervisor, Thomas Tarcza can be reached on 571-272-6979. The fax phone number for the organization where this application or proceeding is assigned is 571-273-8300.

Information regarding the status of an application may be obtained from the Patent Application Information Retrieval (PAIR) system. Status information for published applications may be obtained from either Private PAIR or Public PAIR. Status information for unpublished applications is available through Private PAIR only. For more information about the PAIR system, see <http://pair-direct.uspto.gov>. Should you have questions on access to the Private PAIR system, contact the Electronic Business Center (EBC) at 866-217-9197 (toll-free). If you would like assistance from a USPTO Customer Service Representative or access to the automated information system, call 800-786-9199 (IN USA OR CANADA) or 571-272-1000.

/J. H./  
Examiner, Art Unit 3662

/Thomas H. Tarcza/  
Supervisory Patent Examiner, Art Unit 3662

<b>Notice of References Cited</b>	Application/Control No. 12/460,139	Applicant(s)/Patent Under Reexamination MAGUIRE, BRIAN T.	
	Examiner JAMES HULKA	Art Unit 3662	Page 1 of 1

**U.S. PATENT DOCUMENTS**

*	Document Number Country Code-Number-Kind Code	Date MM-YYYY	Name	Classification	
*	A	US-4,068,209 A	01-1978	Lagier, Michel	367/158
*	B	US-4,538,249 A	08-1985	Richard, Joseph D.	367/94
*	C	US-4,774,837 A	10-1988	Bird, Jeremy	73/181
*	D	US-5,142,502 A	08-1992	Wilcox et al.	367/88
*	E	US-5,438,552 A	08-1995	Audi et al.	367/88
*	F	US-5,561,641 A	10-1996	Nishimori et al.	367/90
*	G	US-5,850,372 A	12-1998	Blue, Joseph E.	367/139
*	H	US-2005/0099887 A1	05-2005	Zimmerman et al.	367/012
*	I	US-2006/0002232 A1	01-2006	Shah et al.	367/082
*	J	US-2007/0025183 A1	02-2007	Zimmerman et al.	367/088
*	K	US-7,542,376 B1	06-2009	Thompson et al.	367/104
	L	US-			
	M	US-			


**FOREIGN PATENT DOCUMENTS**

*	Document Number Country Code-Number-Kind Code	Date MM-YYYY	Country	Name	Classification
	N				
	O				
	P				
	Q				
	R				
	S				
	T				

**NON-PATENT DOCUMENTS**

*	Document Number Country Code-Number-Kind Code	Date MM-YYYY	Country	Name	Classification
	Include as applicable: Author, Title Date, Publisher, Edition or Volume, Pertinent Pages)				
	U	Gary Melvin, Yanchao Li, Larry Mayer, and Allan Clay "Commercial fishing vessels, automatic acoustic logging systems and 3D data visualization" ICES J. Mar. Sci. (2002) 59(1 ): 179-189			
	V				
	W				
	X				

\*A copy of this reference is not being furnished with this Office action. (See MPEP § 707.05(a).)  
Dates in MM-YYYY format are publication dates. Classifications may be US or foreign.

<b>Search Notes</b>  	<b>Application/Control No.</b>  12460139	<b>Applicant(s)/Patent Under Reexamination</b>  MAGUIRE, BRIAN T.
	<b>Examiner</b>  JAMES HULKA	<b>Art Unit</b>  3662

<b>SEARCHED</b>			
<b>Class</b>	<b>Subclass</b>	<b>Date</b>	<b>Examiner</b>
367	88	9/13/2011	JH

<b>SEARCH NOTES</b>		
<b>Search Notes</b>	<b>Date</b>	<b>Examiner</b>
EAST (Keyword and Class Limited)	9/13/2011	JH
PALM (Inventor Name)	9/13/2011	JH
Google (Keyword)	9/13/2011	JH

<b>INTERFERENCE SEARCH</b>			
<b>Class</b>	<b>Subclass</b>	<b>Date</b>	<b>Examiner</b>

/J.H./ Examiner.Art Unit 3662	
----------------------------------	--




Substitute for form 1449/PTO (Revised 07/2007)  <b>INFORMATION DISCLOSURE                  STATEMENT BY APPLICANT</b> (Use as many sheets as necessary)				<b>Complete if Known</b>		
				Application Number	12/460,139	
				Filing Date	July 14, 2009	
				First Named Inventor	Brian T. Maguire	
				Art Unit	3662	
Examiner Name	Not Yet Assigned /James Hulka/					
Sheet	1	of	1	Attorney Docket Number	038495/369324	
<b>U. S. PATENT DOCUMENTS</b>						
Examiner Initials*	Cite No.	Document Number Number - Kind Code (if known)	Publication Date MM-DD-YYYY	Name of Patentee or Applicant of Cited Document	Pages, Columns, Lines, Where Relevant Passages of Relevant Figures Appear	
	1	US-3,618,006	11-02-1971	The Boeing Company		
	2	US-4,879,697	11-07-1989	Lowrance, et al.		
	3	US-5,184,330	02-02-1993	Adams, et al.		
	4	US-5,694,372	12-02-1997	Perennes		
		US-				
		US-				
		US-				
		US-				
<b>FOREIGN PATENT DOCUMENTS</b>						
Examiner Initials	Cite No.	Foreign Patent Document Country Code - Number Kind Code (if known)	Publication Date MM-DD-YYYY	Name of Patentee or Applicant of Cited Document	Pages, Columns, Lines, Where Relevant Passages or Relevant Figures Appear	English Language Translation Attached
	5	WO 98/15846	04-16-1998	Rowe-Deines Instruments, Incorporated		
<b>OTHER DOCUMENTS</b>						
Examiner Initials*	Cite No.	Include name of the author (in CAPITAL LETTERS), title of the article (when appropriate), title of the item (book, magazine, journal, serial, symposium, catalog, etc.), date, page(s), volume-issue number(s), publisher, city and/or country where published.			English Language Translation Attached	
	6	International Search Report and Written Opinion mailed October 6, 2010, for International Application No. PCT/US2010/039443				
Examiner Signature	/James Hulka/		Date Considered	07/26/2011		

\*Examiner: Initial if reference considered, whether or not citation is in conformance with MPEP 609. Draw line through citation if not in conformance and not considered. Include copy of this form with next communication to applicant.

Submitted: October 28, 2010 RAY-1002

563 of 737

ALL REFERENCES CONSIDERED EXCEPT WHERE LINED THROUGH. /J.H./

<b>Index of Claims</b>  	<b>Application/Control No.</b> 12460139	<b>Applicant(s)/Patent Under Reexamination</b> MAGUIRE, BRIAN T.
	<b>Examiner</b> JAMES HULKA	<b>Art Unit</b> 3662

✓	<b>Rejected</b>
=	<b>Allowed</b>


-	<b>Cancelled</b>
÷	<b>Restricted</b>

N	<b>Non-Elected</b>
I	<b>Interference</b>

A	<b>Appeal</b>
O	<b>Objected</b>

Claims renumbered in the same order as presented by applicant
  CPA
  T.D.
  R.1.47

CLAIM		DATE							
Final	Original	07/26/2011	09/13/2011						
	1	÷	N						
	2	÷	N						
	3	÷	N						
	4	÷	N						
	5	÷	N						
	6	÷	N						
	7	÷	N						
	8	÷	N						
	9	÷	N						
	10	÷	N						
	11	÷	N						
	12	÷	N						
	13	÷	N						
	14	÷	N						
	15	÷	N						
	16	÷	N						
	17	÷	N						
	18	÷	N						
	19	÷	N						
	20	÷	N						
	21	÷	N						
	22	÷	N						
	23	÷	N						
	24	÷	N						
	25	÷	N						
	26	÷	N						
	27	÷	N						
	28	÷	N						
	29	÷	N						
	30	÷	N						
	31	÷	N						
	32	÷	N						
	33	÷	N						
	34	÷	N						
	35	÷	N						
	36	÷	N						

<b>Index of Claims</b>  	<b>Application/Control No.</b>  12460139	<b>Applicant(s)/Patent Under Reexamination</b>  MAGUIRE, BRIAN T.
	<b>Examiner</b>  JAMES HULKA	<b>Art Unit</b>  3662

✓	<b>Rejected</b>
=	<b>Allowed</b>


-	<b>Cancelled</b>
÷	<b>Restricted</b>

N	<b>Non-Elected</b>
I	<b>Interference</b>

A	<b>Appeal</b>
O	<b>Objected</b>

Claims renumbered in the same order as presented by applicant
  CPA
  T.D.
  R.1.47

CLAIM		DATE							
Final	Original	07/26/2011	09/13/2011						
	37	÷	N						
	38	÷	N						
	39	÷	N						
	40	÷	N						
	41	÷	N						
	42	÷	N						
	43	÷	N						
	44	÷	N						
	45	÷	N						
	46	÷	N						
	47	÷	N						
	48	÷	N						
	49	÷	N						
	50	÷	N						
	51	÷	N						
	52	÷	N						
	53	÷	N						
	54	÷	N						
	55	÷	N						
	56	÷	N						
	57	÷	✓						
	58	÷	✓						
	59	÷	✓						
	60	÷	✓						
	61	÷	✓						
	62	÷	✓						
	63	÷	✓						
	64	÷	✓						
	65	÷	✓						
	66	÷	✓						
	67	÷	✓						
	68	÷	✓						
	69	÷	✓						
	70	÷	✓						
	71	÷	✓						
	72	÷	✓						

<b>Index of Claims</b>  	<b>Application/Control No.</b>  12460139	<b>Applicant(s)/Patent Under Reexamination</b>  MAGUIRE, BRIAN T.
	<b>Examiner</b>  JAMES HULKA	<b>Art Unit</b>  3662

✓	<b>Rejected</b>
=	<b>Allowed</b>

-	<b>Cancelled</b>
÷	<b>Restricted</b>

N	<b>Non-Elected</b>
I	<b>Interference</b>

A	<b>Appeal</b>
O	<b>Objected</b>

Claims renumbered in the same order as presented by applicant
  CPA
  T.D.
  R.1.47

CLAIM		DATE							
Final	Original	07/26/2011	09/13/2011						
	73	÷	✓						
	74	÷	✓						
	75	÷	✓						
	76	÷	✓						
	77	÷	✓						
	78	÷	✓						
	79	÷	✓						
	80	÷	✓						
	81	÷	✓						
	82	÷	✓						
	83	÷	✓						
	84	÷	✓						
	85	÷	✓						
	86	÷	✓						
	87	÷	✓						
	88	÷	✓						
	89	÷	✓						
	90	÷	✓						
	91	÷	✓						
	92	÷	✓						
	93	÷	✓						
	94	÷	✓						
	95	÷	✓						
	96	÷	✓						
	97	÷	✓						
	98	÷	✓						
	99	÷	✓						

## EAST Search History

## EAST Search History (Prior Art)

Ref #	Hits	Search Query	DBs	Default Operator	Plurals	Time Stamp
L1	108	housing same ((linear\$2 or rectang\$4) near3 transduc\$3) same (acoustic\$3 or sonar or ultraso\$3) and vertical\$3	US-PGPUB; USPAT; USOCR; FPRS; EPO; JPO; DERWENT; IBM_TDB	OR	OFF	2011/09/13 14:55
L2	11	housing same ((linear\$2 or rectang\$4) near3 transduc\$3) same (acoustic\$3 or sonar or ultraso\$3) same vertical\$3	US-PGPUB; USPAT; USOCR; FPRS; EPO; JPO; DERWENT; IBM_TDB	OR	OFF	2011/09/13 14:55
L3	24	housing same ((linear\$2 or rectang\$4) near3 transduc\$3) same (acoustic\$3 or sonar or ultraso\$3) and vertical\$3 and ("367" or "181" or "381").clas.	US-PGPUB; USPAT; USOCR; FPRS; EPO; JPO; DERWENT; IBM_TDB	OR	OFF	2011/09/13 15:05
L5	261	hous\$3 same ((linear\$2 or rectang\$4) near3 transduc\$3) same (acoustic\$3 or sonar or ultraso\$3)	US-PGPUB; USPAT; USOCR; FPRS; EPO; JPO; DERWENT; IBM_TDB	OR	OFF	2011/09/13 15:09
L6	41	hous\$3 same ((linear\$2 or rectang\$4) near3 transduc\$3) same (acoustic\$3 or sonar or ultraso\$3) and "367".clas.	US-PGPUB; USPAT; USOCR; FPRS; EPO; JPO; DERWENT; IBM_TDB	OR	OFF	2011/09/13 15:09
L9	98	hous\$3 same ((linear\$2) same transduc\$3) same (acoustic\$3 or sonar or ultraso\$3) and "367".clas.	US-PGPUB; USPAT; USOCR; FPRS; EPO; JPO; DERWENT; IBM_TDB	OR	OFF	2011/09/13 15:34

L12	10	(US-20110013485-\$ or US-20070025183-\$ or US-20050099887-\$ or US-20060002232-\$).did. or (US-5694372-\$ or US-5184330-\$ or US-4879697-\$ or US-3618006-\$ or US-5561641-\$ or US-7542376-\$).did.	US-PGPUB; USPAT	OR	OFF	2011/09/13 15:40
L13	9	L12 and frequenc\$3	US-PGPUB; USPAT; USOCR; FPRS; EPO; JPO; DERWENT; IBM_TDB	OR	OFF	2011/09/13 15:40
L14	3	transducer\$3 same sonar same beam\$3 same ("32" adj degree\$2)	US-PGPUB; USPAT; USOCR; FPRS; EPO; JPO; DERWENT; IBM_TDB	OR	OFF	2011/09/13 15:53
L15	0	transducer\$3 same sonar same beam\$3 same ("30" adj degree\$2) and ("1" adj degree)	US-PGPUB; USPAT; USOCR; FPRS; EPO; JPO; DERWENT; IBM_TDB	OR	OFF	2011/09/13 15:55
L16	0	transducer\$3 and sonar same beam\$3 same ("30" adj degree\$2) and ("1" adj degree)	US-PGPUB; USPAT; USOCR; FPRS; EPO; JPO; DERWENT; IBM_TDB	OR	OFF	2011/09/13 15:55
L17	6	transducer\$3 and sonar same beam\$3 same ("1" adj degree)	US-PGPUB; USPAT; USOCR; FPRS; EPO; JPO; DERWENT; IBM_TDB	OR	OFF	2011/09/13 15:56
L18	89	sonar near3 image\$2 near3 display\$2	US-PGPUB; USPAT; USOCR; FPRS; EPO; JPO; DERWENT; IBM_TDB	OR	OFF	2011/09/13 16:14
L19	24	sonar near3 image\$2 near3 display\$2 same (plural\$3 or multiple\$2)	US-PGPUB; USPAT; USOCR; FPRS; EPO; JPO; DERWENT; IBM_TDB	OR	OFF	2011/09/13 16:17

L20	6	L12 and configuration\$2	US-PGPUB; USPAT; USOCR; FPRS; EPO; JPO; DERWENT; IBM_TDB	OR	OFF	2011/09/13 16:22
L21	1	L12 and configuration\$2 near3 display\$2	US-PGPUB; USPAT; USOCR; FPRS; EPO; JPO; DERWENT; IBM_TDB	OR	OFF	2011/09/13 16:22
L22	2	L12 and setting\$2 near3 display\$2	US-PGPUB; USPAT; USOCR; FPRS; EPO; JPO; DERWENT; IBM_TDB	OR	OFF	2011/09/13 16:23
L23	0	sonar near3 setting\$2 near3 display\$2	US-PGPUB; USPAT; USOCR; FPRS; EPO; JPO; DERWENT; IBM_TDB	OR	OFF	2011/09/13 16:23
L24	18	sonar same setting\$2 near3 display\$2	US-PGPUB; USPAT; USOCR; FPRS; EPO; JPO; DERWENT; IBM_TDB	OR	OFF	2011/09/13 16:23
L25	8	sonar same transducer\$2 same ("3" adj mm)	US-PGPUB; USPAT; USOCR; FPRS; EPO; JPO; DERWENT; IBM_TDB	OR	OFF	2011/09/13 16:25
L26	104	sonar same transducer\$2 and ("2" adj mm)	US-PGPUB; USPAT; USOCR; FPRS; EPO; JPO; DERWENT; IBM_TDB	OR	OFF	2011/09/13 16:27
L27	1607	sonar same transducer\$2 and width	US-PGPUB; USPAT; USOCR; FPRS; EPO; JPO; DERWENT; IBM_TDB	OR	OFF	2011/09/13 16:29

L28	59	sonar same transducer\$2 near4 width	US-PGPUB; USPAT; USOCR; FPRS; EPO; JPO; DERWENT; IBM_TDB	OR	OFF	2011/09/13 16:29
L29	104	sonar same transducer\$2 near4 length\$2	US-PGPUB; USPAT; USOCR; FPRS; EPO; JPO; DERWENT; IBM_TDB	OR	OFF	2011/09/13 16:35
L30	4	sonar same transducer\$2 near4 length\$2 same mm	US-PGPUB; USPAT; USOCR; FPRS; EPO; JPO; DERWENT; IBM_TDB	OR	OFF	2011/09/13 16:35
L31	2123	("800" adj khz)	US-PGPUB; USPAT; USOCR; FPRS; EPO; JPO; DERWENT; IBM_TDB	OR	OFF	2011/09/13 18:03
L32	48	("800" adj khz) near3 (acoustic\$2 or sonar or ultraso\$3)	US-PGPUB; USPAT; USOCR; FPRS; EPO; JPO; DERWENT; IBM_TDB	OR	OFF	2011/09/13 18:03
L33	406	367/88.ccls.	US-PGPUB; USPAT; USOCR; FPRS; EPO; JPO; DERWENT; IBM_TDB	OR	OFF	2011/09/13 18:08
L34	2727	maguire.in.	US-PGPUB; USPAT; USOCR; FPRS; EPO; JPO; DERWENT; IBM_TDB	OR	OFF	2011/09/13 18:08
L35	17	(brian near2 maguire).in.	US-PGPUB; USPAT; USOCR; FPRS; EPO; JPO; DERWENT; IBM_TDB	OR	OFF	2011/09/13 18:08



L36	2	(brian near2 maguire).in. and "367".clas.	US-PGPUB; USPAT; USOCR; FPRS; EPO; JPO; DERWENT; IBM_TDB	OR	OFF	2011/09/13 18:08
S1	2	"20110013485".pn.	US-PGPUB; USPAT; USOCR; FPRS; EPO; JPO; DERWENT; IBM_TDB	OR	OFF	2011/07/21 17:36
S2	9	("3618006"   "4879697"   "5184330"   "5694372"). PN.	US-PGPUB; USPAT; USOCR; FPRS; EPO; JPO; DERWENT; IBM_TDB	OR	OFF	2011/07/21 17:38
S3	5283	@pd="19980416"	US-PGPUB; USPAT; USOCR; FPRS; EPO; JPO; DERWENT; IBM_TDB	OR	OFF	2011/07/21 17:39
S4	108	("6118733" "20110013485" "20110013484" "4287578" "6130641" "5412618" "5515337" "4958330" "5537366" "4288764" "5022015" "5237542" "5287330" "5327397" "5703906" "5323362" "4253166" "20080002526" "5504716" "5764595" "4815045" "5182732" "20090031940" "4525816" "5484969" "4287580" "4445186" "4509153" "4596007" "4779239" "4845687" "4958331" "4964106" "4965776" "5033032" "5187690" "5220537" "5223846" "5383457" "5440155" "5512907" "5549111" "5598206" "5673236" "5719823" "5729171" "5865748" "5926439" "5986972" "6111820").pn.	US-PGPUB; USPAT; USOCR; FPRS; EPO; JPO; DERWENT; IBM_TDB	OR	OFF	2011/09/12 18:17

S5	134	("5173882" "20110013485" "5220537" "7833158" "20060181457" "4845687" "7047132" "4274148" "4305141" "4571711" "4641290" "4833360" "4864179" "4987563" "5530678" "5642329" "6050361" "6097671" "6285628" "6341661" "20030227825" "20080291121" "3800273" "3806862" "4232380" "6052334" "6700834" "6950372" "20020018400" "20040037166" "20110013484" "3582872" "3618006" "3784805" "3859622" "3864666" "4030062" "4119940" "4190818" "4199746" "4244026" "4433396" "4460987" "4463454" "4596007" "4631710" "4638467" "4725988" "4831602" "4878207").pn.	US-PGPUB; USPAT; USOCR; FPRS; EPO; JPO; DERWENT; IBM_TDB	OR	OFF	2011/09/12 18:18
S6	26	("20040184351"   "20050043619"   "20050099887"   "20070025183"   "20070091723"   "5200931"   "5245587"   "5455806"   "5561641"   "6084827"   "6421299"   "6449215"   "7542376"). PN.	US-PGPUB; USPAT; USOCR; FPRS; EPO; JPO; DERWENT; IBM_TDB	OR	OFF	2011/09/12 18:23
S7	0	(S4 or S5) and S6	US-PGPUB; USPAT; USOCR; FPRS; EPO; JPO; DERWENT; IBM_TDB	OR	OFF	2011/09/12 18:24

9/ 13/ 2011 7:03:56 PM

H:\ 12-400\ 12460139a.wsp


**UNITED STATES PATENT AND TRADEMARK OFFICE**

UNITED STATES DEPARTMENT OF COMMERCE  
**United States Patent and Trademark Office**  
 Address: COMMISSIONER FOR PATENTS  
 P.O. Box 1450  
 Alexandria, Virginia 22313-1450  
 www.uspto.gov

**BIB DATA SHEET**
**CONFIRMATION NO. 9769**

SERIAL NUMBER	FILING or 371(c) DATE	CLASS	GROUP ART UNIT	ATTORNEY DOCKET NO.		
12/460,139	07/14/2009	367	3662	038495/369324		
<b>APPLICANTS</b> Brian T. Maguire, Broken Arrow, OK;						
** CONTINUING DATA *****						
** FOREIGN APPLICATIONS *****						
** IF REQUIRED, FOREIGN FILING LICENSE GRANTED ** 07/28/2009						
Foreign Priority claimed 35 USC 119(a-d) conditions met Verified and Acknowledged	<input type="checkbox"/> Yes <input checked="" type="checkbox"/> No  <input type="checkbox"/> Yes <input checked="" type="checkbox"/> No  /JAMES R HULKA/ Examiner's Signature	<input type="checkbox"/> Met after Allowance  Initials	<b>STATE OR COUNTRY</b>  OK	<b>SHEETS DRAWINGS</b>  23	<b>TOTAL CLAIMS</b>  99	<b>INDEPENDENT CLAIMS</b>  4
<b>ADDRESS</b>  ALSTON & BIRD LLP BANK OF AMERICA PLAZA 101 SOUTH TRYON STREET, SUITE 4000 CHARLOTTE, NC 28280-4000 UNITED STATES						
<b>TITLE</b>  Downscan imaging sonar						
<b>FILING FEE RECEIVED</b>  5548	FEES: Authority has been given in Paper No. _____ to charge/credit DEPOSIT ACCOUNT No. _____ for following:		<input type="checkbox"/> All Fees <input type="checkbox"/> 1.16 Fees (Filing) <input type="checkbox"/> 1.17 Fees (Processing Ext. of time) <input type="checkbox"/> 1.18 Fees (Issue) <input type="checkbox"/> Other _____ <input type="checkbox"/> Credit			

IN THE UNITED STATES PATENT AND TRADEMARK OFFICE

In re: Maguire Confirmation No.: 9769  
Appl. No.: 12/460,139 Group Art Unit: 3662  
Filed: 07/14/2009 Examiner: James R. Hulka  
For: DOWNSCAN IMAGING SONAR

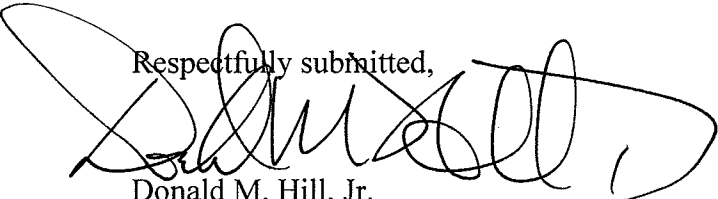
Mail Stop Amendment  
Commissioner for Patents  
P.O. Box 1450  
Alexandria, VA 22313-1450

**RESPONSE TO RESTRICTION REQUIREMENT**

This is in response to the Office Action dated July 28, 2011, in which the Examiner has required restriction between Species I and Species II. Species I is described in Claims 1-56, drawn to a plurality of rectangular transducers, and a sonar system including the plurality of rectangular transducers. Species II is described in Claims 57-99, drawn to a linear transducer array, and a sonar system including the linear transducer array. Applicant hereby elects to prosecute the claims of **Species II (Claims 57-99)** and expressly reserves the right to file divisional applications or take such other appropriate measures deemed necessary to protect the inventions in the remaining claims.

It is not believed that extensions of time or fees for net addition of claims are required, beyond those, which may otherwise be provided for in documents accompanying this paper. However, in the event that additional extensions of time are necessary to allow consideration of this paper, such extensions are hereby petitioned under 37 CFR § 1.136(a), and any fee required therefor (including fees for net addition of claims) is hereby authorized to be charged to Deposit Account No. 16-0605.

Respectfully submitted,

  
Donald M. Hill, Jr.  
Registration No. 40,646

**Customer No. 00826**  
**ALSTON & BIRD LLP**  
101 South Tryon Street, Suite 4000  
Charlotte, NC 28280-4000  
Tel Charlotte Office (704) 444-1000

ELECTRONICALLY FILED USING THE EFS-WEB ELECTRONIC FILING SYSTEM OF THE UNITED STATES PATENT & TRADEMARK OFFICE ON AUGUST 29, 2011.

## Electronic Acknowledgement Receipt

<b>EFS ID:</b>	10835514
<b>Application Number:</b>	12460139
<b>International Application Number:</b>	
<b>Confirmation Number:</b>	9769
<b>Title of Invention:</b>	Downscan imaging sonar
<b>First Named Inventor/Applicant Name:</b>	Brian T. Maguire
<b>Customer Number:</b>	00826
<b>Filer:</b>	John Elmus Johnson/Jan Moore
<b>Filer Authorized By:</b>	John Elmus Johnson
<b>Attorney Docket Number:</b>	038495/369324
<b>Receipt Date:</b>	29-AUG-2011
<b>Filing Date:</b>	14-JUL-2009
<b>Time Stamp:</b>	16:20:43
<b>Application Type:</b>	Utility under 35 USC 111(a)

### Payment information:

Submitted with Payment	no
------------------------	----

### File Listing:

Document Number	Document Description	File Name	File Size(Bytes)/ Message Digest	Multi Part /.zip	Pages (if appl.)
1	Response to Election / Restriction Filed	369324_Election.pdf	58004 <small>d354f804b49ffe11b03b06bb78b9c0ddb3b0c760</small>	no	1

### Warnings:

RAY-1002

### Information:

575 of 737

This Acknowledgement Receipt evidences receipt on the noted date by the USPTO of the indicated documents, characterized by the applicant, and including page counts, where applicable. It serves as evidence of receipt similar to a Post Card, as described in MPEP 503.

**New Applications Under 35 U.S.C. 111**

If a new application is being filed and the application includes the necessary components for a filing date (see 37 CFR 1.53(b)-(d) and MPEP 506), a Filing Receipt (37 CFR 1.54) will be issued in due course and the date shown on this Acknowledgement Receipt will establish the filing date of the application.

**National Stage of an International Application under 35 U.S.C. 371**

If a timely submission to enter the national stage of an international application is compliant with the conditions of 35 U.S.C. 371 and other applicable requirements a Form PCT/DO/EO/903 indicating acceptance of the application as a national stage submission under 35 U.S.C. 371 will be issued in addition to the Filing Receipt, in due course.

**New International Application Filed with the USPTO as a Receiving Office**

If a new international application is being filed and the international application includes the necessary components for an international filing date (see PCT Article 11 and MPEP 1810), a Notification of the International Application Number and of the International Filing Date (Form PCT/RO/105) will be issued in due course, subject to prescriptions concerning national security, and the date shown on this Acknowledgement Receipt will establish the international filing date of the application.



UNITED STATES PATENT AND TRADEMARK OFFICE

UNITED STATES DEPARTMENT OF COMMERCE  
United States Patent and Trademark Office  
Address: COMMISSIONER FOR PATENTS  
P.O. Box 1450  
Alexandria, Virginia 22313-1450  
www.uspto.gov

APPLICATION NO.	FILING DATE	FIRST NAMED INVENTOR	ATTORNEY DOCKET NO.	CONFIRMATION NO.
12/460,139	07/14/2009	Brian T. Maguire	038495/369324	9769

826 7590 07/28/2011  
ALSTON & BIRD LLP  
BANK OF AMERICA PLAZA  
101 SOUTH TRYON STREET, SUITE 4000  
CHARLOTTE, NC 28280-4000

EXAMINER

HULKA, JAMES R

ART UNIT PAPER NUMBER

3662

MAIL DATE DELIVERY MODE

07/28/2011

PAPER

**Please find below and/or attached an Office communication concerning this application or proceeding.**

The time period for reply, if any, is set in the attached communication.

**Office Action Summary**

<b>Application No.</b> 12/460,139	<b>Applicant(s)</b> MAGUIRE, BRIAN T.	
<b>Examiner</b> JAMES HULKA	<b>Art Unit</b> 3662	

-- The MAILING DATE of this communication appears on the cover sheet with the correspondence address --

**Period for Reply**

A SHORTENED STATUTORY PERIOD FOR REPLY IS SET TO EXPIRE 1 MONTH(S) OR THIRTY (30) DAYS, WHICHEVER IS LONGER, FROM THE MAILING DATE OF THIS COMMUNICATION.

- Extensions of time may be available under the provisions of 37 CFR 1.136(a). In no event, however, may a reply be timely filed after SIX (6) MONTHS from the mailing date of this communication.
- If NO period for reply is specified above, the maximum statutory period will apply and will expire SIX (6) MONTHS from the mailing date of this communication.
- Failure to reply within the set or extended period for reply will, by statute, cause the application to become ABANDONED (35 U.S.C. § 133). Any reply received by the Office later than three months after the mailing date of this communication, even if timely filed, may reduce any earned patent term adjustment. See 37 CFR 1.704(b).

**Status**

- 1)  Responsive to communication(s) filed on 14 July 2009.
- 2a)  This action is **FINAL**.
- 2b)  This action is non-final.
- 3)  Since this application is in condition for allowance except for formal matters, prosecution as to the merits is closed in accordance with the practice under *Ex parte Quayle*, 1935 C.D. 11, 453 O.G. 213.

**Disposition of Claims**

- 4)  Claim(s) 1-99 is/are pending in the application.  
4a) Of the above claim(s) \_\_\_\_\_ is/are withdrawn from consideration.
- 5)  Claim(s) \_\_\_\_\_ is/are allowed.
- 6)  Claim(s) \_\_\_\_\_ is/are rejected.
- 7)  Claim(s) \_\_\_\_\_ is/are objected to.
- 8)  Claim(s) 1-99 are subject to restriction and/or election requirement.

**Application Papers**

- 9)  The specification is objected to by the Examiner.
- 10)  The drawing(s) filed on \_\_\_\_\_ is/are: a)  accepted or b)  objected to by the Examiner.  
Applicant may not request that any objection to the drawing(s) be held in abeyance. See 37 CFR 1.85(a).  
Replacement drawing sheet(s) including the correction is required if the drawing(s) is objected to. See 37 CFR 1.121(d).
- 11)  The oath or declaration is objected to by the Examiner. Note the attached Office Action or form PTO-152.

**Priority under 35 U.S.C. § 119**

- 12)  Acknowledgment is made of a claim for foreign priority under 35 U.S.C. § 119(a)-(d) or (f).  
a)  All   b)  Some \*   c)  None of:  
1.  Certified copies of the priority documents have been received.  
2.  Certified copies of the priority documents have been received in Application No. \_\_\_\_\_.  
3.  Copies of the certified copies of the priority documents have been received in this National Stage application from the International Bureau (PCT Rule 17.2(a)).

\* See the attached detailed Office action for a list of the certified copies not received.

**Attachment(s)**

- 1)  Notice of References Cited (PTO-892)
- 2)  Notice of Draftsperson's Patent Drawing Review (PTO-948)
- 3)  Information Disclosure Statement(s) (PTO/SB/08)  
Paper No(s)/Mail Date \_\_\_\_\_.
- 4)  Interview Summary (PTO-413)  
Paper No(s)/Mail Date \_\_\_\_\_.
- 5)  Notice of Informal Patent Application
- 6)  Other: \_\_\_\_\_.



## DETAILED ACTION

### *Election/Restrictions*

1. This application contains claims directed to the following patentably distinct Species I and II. *The species are independent or distinct because Species II includes a linear transducer array (Fig. 14) and has a different functionality than Species I which uses a plurality of planar arrays.* Linear and planar arrays use different mathematical equations in determining directivity of objects detected, require different costs, and potentially different levels of accuracy or efficiency. In addition, these species are not obvious variants of each other based on the current record. **Species I is described in Claims 1-56**, drawn to a plurality of rectangular transducers, and a sonar system including and using the plurality of rectangular transducers, classified in class 367, subclasses 153 and 88.. **Species II is described in Claims 57-99**, drawn to a linear transducer array, and a sonar system using and including the linear transducer array, classified in class 367, subclasses 154 and 87.

Applicant is required under 35 U.S.C. 121 to ***elect a single disclosed species, or a single grouping of patentably indistinct species***, for prosecution on the merits to which the claims shall be restricted if no generic claim is finally held to be allowable. Currently, a sonar system comprising one or more transducer arrays are generic.

There is a search and/or examination burden for the patentably distinct species as set forth above because at least the following reason(s) apply:

**The application as written describes inventions that require searches in 4 different subclasses.**

Art Unit: 3662

**Applicant is advised that the reply to this requirement to be complete must include (i) an election of a species or a grouping of patentably indistinct species to be examined even though the requirement may be traversed (37 CFR 1.143) and (ii) identification of the claims encompassing the elected species or grouping of patentably indistinct species**, including any claims subsequently added. An argument that a claim is allowable or that all claims are generic is considered nonresponsive unless accompanied by an election.

The election may be made with or without traverse. To preserve a right to petition, the election must be made with traverse. If the reply does not distinctly and specifically point out supposed errors in the election of species requirement, the election shall be treated as an election without traverse. Traversal must be presented at the time of election in order to be considered timely. Failure to timely traverse the requirement will result in the loss of right to petition under 37 CFR 1.144. If claims are added after the election, applicant must indicate which of these claims are readable on the elected species or grouping of patentably indistinct species.

Should applicant traverse on the ground that the species, or groupings of patentably indistinct species from which election is required, are not patentably distinct, applicant should submit evidence or identify such evidence now of record showing them to be obvious variants or clearly admit on the record that this is the case. In either instance, if the examiner finds one of the species unpatentable over the prior art, the evidence or admission may be used in a rejection under 35 U.S.C. 103(a) of the other species.

Upon the allowance of a generic claim, applicant will be entitled to consideration of claims to additional species which depend from or otherwise require all the limitations of an allowable generic claim as provided by 37 CFR 1.141.

### ***Conclusion***

Any inquiry concerning this communication or earlier communications from the examiner should be directed to JAMES HULKA whose telephone number is (571)270-7553. The examiner can normally be reached on Monday thru Thursday 7:30am-5pm, Every 2nd Friday, 7:30am - 4pm.

If attempts to reach the examiner by telephone are unsuccessful, the examiner's supervisor, Thomas Tarcza can be reached on 571-272-6979. The fax phone number for the organization where this application or proceeding is assigned is 571-273-8300.

Information regarding the status of an application may be obtained from the Patent Application Information Retrieval (PAIR) system. Status information for published applications may be obtained from either Private PAIR or Public PAIR. Status information for unpublished applications is available through Private PAIR only. For more information about the PAIR system, see <http://pair-direct.uspto.gov>. Should you have questions on access to the Private PAIR system, contact the Electronic Business Center (EBC) at 866-217-9197 (toll-free). If you would like assistance from a USPTO Customer Service Representative or access to the automated information system, call 800-786-9199 (IN USA OR CANADA) or 571-272-1000.


Application/Control Number: 12/460,139  
Art Unit: 3662

Page 5

/J. H./  
Examiner, Art Unit 3662

/Thomas H. Tarcza/

Supervisory Patent Examiner, Art Unit 3662

<b>Index of Claims</b>  	<b>Application/Control No.</b>  12460139	<b>Applicant(s)/Patent Under Reexamination</b>  MAGUIRE, BRIAN T.
	<b>Examiner</b>  JAMES HULKA	<b>Art Unit</b>  3662

✓	<b>Rejected</b>
=	<b>Allowed</b>


-	<b>Cancelled</b>
÷	<b>Restricted</b>

N	<b>Non-Elected</b>
I	<b>Interference</b>

A	<b>Appeal</b>
O	<b>Objected</b>

Claims renumbered in the same order as presented by applicant
  CPA
  T.D.
  R.1.47

CLAIM		DATE							
Final	Original	07/26/2011							
	1	+							
	2	+							
	3	+							
	4	+							
	5	+							
	6	+							
	7	+							
	8	+							
	9	+							
	10	+							
	11	+							
	12	+							
	13	+							
	14	+							
	15	+							
	16	+							
	17	+							
	18	+							
	19	+							
	20	+							
	21	+							
	22	+							
	23	+							
	24	+							
	25	+							
	26	+							
	27	+							
	28	+							
	29	+							
	30	+							
	31	+							
	32	+							
	33	+							
	34	+							
	35	+							
	36	+							

<b><i>Index of Claims</i></b>  	<b>Application/Control No.</b> 12460139	<b>Applicant(s)/Patent Under Reexamination</b> MAGUIRE, BRIAN T.
	<b>Examiner</b> JAMES HULKA	<b>Art Unit</b> 3662

✓	<b>Rejected</b>
=	<b>Allowed</b>


-	<b>Cancelled</b>
÷	<b>Restricted</b>

N	<b>Non-Elected</b>
I	<b>Interference</b>

A	<b>Appeal</b>
O	<b>Objected</b>

Claims renumbered in the same order as presented by applicant
  CPA
  T.D.
  R.1.47

CLAIM		DATE							
Final	Original	07/26/2011							
	37	÷							
	38	÷							
	39	÷							
	40	÷							
	41	÷							
	42	÷							
	43	÷							
	44	÷							
	45	÷							
	46	÷							
	47	÷							
	48	÷							
	49	÷							
	50	÷							
	51	÷							
	52	÷							
	53	÷							
	54	÷							
	55	÷							
	56	÷							
	57	÷							
	58	÷							
	59	÷							
	60	÷							
	61	÷							
	62	÷							
	63	÷							
	64	÷							
	65	÷							
	66	÷							
	67	÷							
	68	÷							
	69	÷							
	70	÷							
	71	÷							
	72	÷							

<b>Index of Claims</b>  	<b>Application/Control No.</b> 12460139	<b>Applicant(s)/Patent Under Reexamination</b> MAGUIRE, BRIAN T.
	<b>Examiner</b> JAMES HULKA	<b>Art Unit</b> 3662

✓	<b>Rejected</b>
=	<b>Allowed</b>

-	<b>Cancelled</b>
÷	<b>Restricted</b>

N	<b>Non-Elected</b>
I	<b>Interference</b>

A	<b>Appeal</b>
O	<b>Objected</b>

Claims renumbered in the same order as presented by applicant
  CPA
  T.D.
  R.1.47

CLAIM		DATE							
Final	Original	07/26/2011							
	73	÷							
	74	÷							
	75	÷							
	76	÷							
	77	÷							
	78	÷							
	79	÷							
	80	÷							
	81	÷							
	82	÷							
	83	÷							
	84	÷							
	85	÷							
	86	÷							
	87	÷							
	88	÷							
	89	÷							
	90	÷							
	91	÷							
	92	÷							
	93	÷							
	94	÷							
	95	÷							
	96	÷							
	97	÷							
	98	÷							
	99	÷							

PLUS Search Results for S/N 12460139, Searched Fri Jul 22 08:50:33 EDT 2011

The Patent Linguistics Utility System (PLUS) is a USPTO automated search system for U.S. Patents from 1971 to the present PLUS is a query-by-example search system which produces a list of patents that are most closely related linguistically to the application searched. This search was prepared by the staff of the Scientific and Technical Information Center, SIRA.

20110013485 92	6118733 56
20110013484 86	
4287578 68	
6130641 64	
5412618 64	
5515337 64	
4958330 62	
5537366 62	
4288764 62	
5022015 62	
5237542 62	
5287330 62	
5327397 62	
5703906 62	
5323362 61	
4253166 60	
20080002526 60	
5504716 59	
5764595 59	
4815045 58	
5182732 58	
20090031940 58	
4525816 56	
5484969 56	
4287580 56	
4445186 56	
4509153 56	
4596007 56	
4779239 56	
4845687 56	
4958331 56	
4964106 56	
4965776 56	
5033032 56	
5187690 56	
5220537 56	
5223846 56	
5383457 56	
5440155 56	
5512907 56	
5549111 56	
5598206 56	
5673236 56	
5719823 56	
5729171 56	
5865748 56	
5926439 56	
5986972 56	
6111820 56	



PLUS Search Results for S/N 12460139, Searched Fri Jul 22 08:50:31 EDT 2011

The Patent Linguistics Utility System (PLUS) is a USPTO automated search system for U.S. Patents from 1971 to the present PLUS is a query-by-example search system which produces a list of patents that are most closely related linguistically to the application searched. This search was prepared by the staff of the Scientific and Technical Information Center, SIRA.

20110013485 99	5173882 76
5220537 86	
7833158 86	
20060181457 86	
4845687 85	
7047132 82	
4274148 82	
4305141 82	
4571711 82	
4641290 82	
4833360 82	
4864179 82	
4987563 82	
5530678 82	
5642329 82	
6050361 82	
6097671 82	
6285628 82	
6341661 82	
20030227825 82	
20080291121 82	
3800273 78	
3806862 78	
4232380 78	
6052334 78	
6700834 78	
6950372 78	
20020018400 78	
20040037166 78	
20110013484 78	
3582872 76	
3618006 76	
3784805 76	
3859622 76	
3864666 76	
4030062 76	
4119940 76	
4190818 76	
4199746 76	
4244026 76	
4433396 76	
4460987 76	
4463454 76	
4596007 76	
4631710 76	
4638467 76	
4725988 76	
4831602 76	
4878207 76	



UNITED STATES PATENT AND TRADEMARK OFFICE

UNITED STATES DEPARTMENT OF COMMERCE  
United States Patent and Trademark Office  
Address: COMMISSIONER FOR PATENTS  
P.O. Box 1450  
Alexandria, Virginia 22313-1450  
www.uspto.gov

APPLICATION NO.	FILING DATE	FIRST NAMED INVENTOR	ATTORNEY DOCKET NO.	CONFIRMATION NO.
12/460,139	07/14/2009	Brian T. Maguire	038495/369324	9769

826 7590 05/10/2011  
ALSTON & BIRD LLP  
BANK OF AMERICA PLAZA  
101 SOUTH TRYON STREET, SUITE 4000  
CHARLOTTE, NC 28280-4000

EXAMINER

LOBO, IAN J

ART UNIT PAPER NUMBER

3662

MAIL DATE DELIVERY MODE

05/10/2011

PAPER

Please find below and/or attached an Office communication concerning this application or proceeding.

The time period for reply, if any, is set in the attached communication.



**MAY 10 2011**

In re Application of : DECISION ON PETITION  
Brian T. Maguire :  
SERIAL NO.: 12/460,139 :  
FILED: July 14, 2009 :  
FOR: DOWNSCAN IMAGING SONAR :

This is a decision on the request filed July 14, 2009 to waive the requirements of 37 CFR 1.84(a) so as to permit the application to include a color drawing. Applicant has shown that the use of color is an essential element in the representation of the drawing.

Petition Granted.

Thomas H. Tarcza  
SPE, Art Unit 3662  
571-272-6979



UNITED STATES PATENT AND TRADEMARK OFFICE

UNITED STATES DEPARTMENT OF COMMERCE
United States Patent and Trademark Office
Address: COMMISSIONER FOR PATENTS
P.O. Box 1450
Alexandria, Virginia 22313-1450
www.uspto.gov

Table with 4 columns: APPLICATION NUMBER (12/460,139), FILING OR 371(C) DATE (07/14/2009), FIRST NAMED APPLICANT (Brian T. Maguire), ATTY. DOCKET NO./TITLE (038495/369324)

CONFIRMATION NO. 9769

PUBLICATION NOTICE



826
ALSTON & BIRD LLP
BANK OF AMERICA PLAZA
101 SOUTH TRYON STREET, SUITE 4000
CHARLOTTE, NC 28280-4000

Title:Downscan imaging sonar

Publication No.US-2011-0013485-A1

Publication Date:01/20/2011

NOTICE OF PUBLICATION OF APPLICATION

The above-identified application will be electronically published as a patent application publication pursuant to 37 CFR 1.211, et seq. The patent application publication number and publication date are set forth above.

The publication may be accessed through the USPTO's publically available Searchable Databases via the Internet at www.uspto.gov. The direct link to access the publication is currently http://www.uspto.gov/patft/.

The publication process established by the Office does not provide for mailing a copy of the publication to applicant. A copy of the publication may be obtained from the Office upon payment of the appropriate fee set forth in 37 CFR 1.19(a)(1). Orders for copies of patent application publications are handled by the USPTO's Office of Public Records. The Office of Public Records can be reached by telephone at (703) 308-9726 or (800) 972-6382, by facsimile at (703) 305-8759, by mail addressed to the United States Patent and Trademark Office, Office of Public Records, Alexandria, VA 22313-1450 or via the Internet.

In addition, information on the status of the application, including the mailing date of Office actions and the dates of receipt of correspondence filed in the Office, may also be accessed via the Internet through the Patent Electronic Business Center at www.uspto.gov using the public side of the Patent Application Information and Retrieval (PAIR) system. The direct link to access this status information is currently http://pair.uspto.gov/. Prior to publication, such status information is confidential and may only be obtained by applicant using the private side of PAIR.

Further assistance in electronically accessing the publication, or about PAIR, is available by calling the Patent Electronic Business Center at 1-866-217-9197.

Office of Data Management, Application Assistance Unit (571) 272-4000, or (571) 272-4200, or 1-888-786-0101

Substitute for form 1449/PTO (Revised 07/2007)  <b>INFORMATION DISCLOSURE          STATEMENT BY APPLICANT</b> <i>(Use as many sheets as necessary)</i>				<b>Complete if Known</b>		
				Application Number	12/460,139	
				Filing Date	July 14, 2009	
				First Named Inventor	Brian T. Maguire	
				Art Unit	3662	
Examiner Name	Not Yet Assigned					
Sheet	1	of	1	Attorney Docket Number	038495/369324	
<b>U. S. PATENT DOCUMENTS</b>						
Examiner Initials*	Cite No.	Document Number Number - Kind Code (if known)	Publication Date MM-DD-YYYY	Name of Patentee or Applicant of Cited Document	Pages, Columns, Lines, Where Relevant Passages of Relevant Figures Appear	
	1	US-3,618,006	11-02-1971	The Boeing Company		
	2	US-4,879,697	11-07-1989	Lowrance, et al.		
	3	US-5,184,330	02-02-1993	Adams, et al.		
	4	US-5,694,372	12-02-1997	Perennes		
		US-				
		US-				
		US-				
		US-				
<b>FOREIGN PATENT DOCUMENTS</b>						
Examiner Initials	Cite No.	Foreign Patent Document Country Code - Number Kind Code (if known)	Publication Date MM-DD-YYYY	Name of Patentee or Applicant of Cited Document	Pages, Columns, Lines, Where Relevant Passages or Relevant Figures Appear	English Language Translation Attached
	5	WO 98/15846	04-16-1998	Rowe-Deines Instruments, Incorporated		
<b>OTHER DOCUMENTS</b>						
Examiner Initials*	Cite No.	Include name of the author (in CAPITAL LETTERS), title of the article (when appropriate), title of the item (book, magazine, journal, serial, symposium, catalog, etc.), date, page(s), volume-issue number(s), publisher, city and/or country where published.			English Language Translation Attached	
	6	International Search Report and Written Opinion mailed October 6, 2010, for International Application No. PCT/US2010/039443				
Examiner Signature				Date Considered		

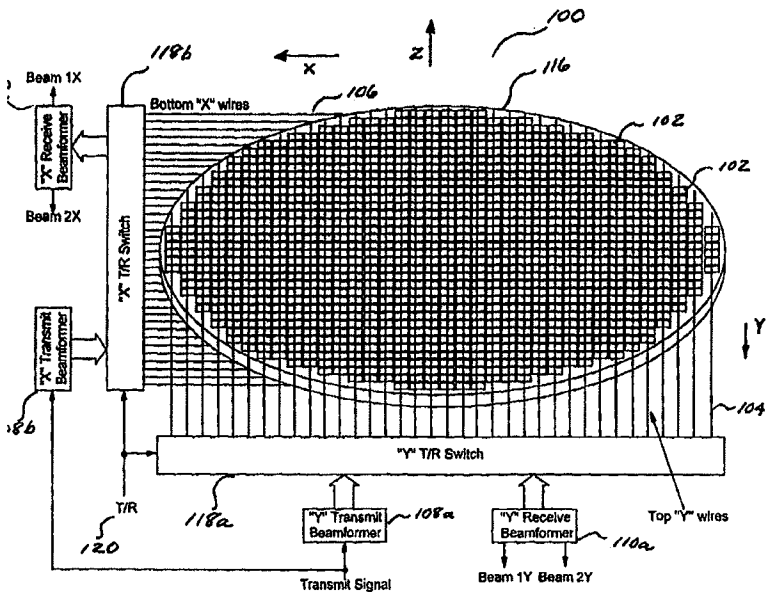
\*Examiner: Initial if reference considered, whether or not citation is in conformance with MPEP 609. Draw line through citation if not in conformance and not considered. Include copy of this form with next communication to applicant.



INTERNATIONAL APPLICATION PUBLISHED UNDER THE PATENT COOPERATION TREATY (PCT)

<p>(51) International Patent Classification <sup>6</sup> : <b>G01S 15/60, 15/89</b></p>	<p><b>A1</b></p>	<p>(11) International Publication Number: <b>WO 98/15846</b> (43) International Publication Date: 16 April 1998 (16.04.98)</p>
<p>(21) International Application Number: PCT/US97/18061 (22) International Filing Date: 7 October 1997 (07.10.97) (30) Priority Data: 08/726,644 7 October 1996 (07.10.96) US (71) Applicant: ROWE-DEINES INSTRUMENTS, INCORPORATED [US/US]; 9855 Businesspark Avenue, San Diego, CA 92131 (US). (72) Inventors: YU, Xiaolong; 10631 Calston Way, San Diego, CA 92126 (US). BRADLEY, Steven, E.; 5096 Corte Playa Catalina, San Diego, CA 92124 (US). ROWE, Francis, D.; 5723 Lodi Street, San Diego, CA 92117 (US). (74) Agent: SIMPSON, Andrew, H.; Knobbe, Martens, Olson and Bear, 16th floor, 620 Newport Center Drive, Newport Beach, CA 92660 (US).</p>		<p>(81) Designated States: JP, NO, European patent (AT, BE, CH, DE, DK, ES, FI, FR, GB, GR, IE, IT, LU, MC, NL, PT, SE).  <b>Published</b> <i>With international search report.</i></p>

(54) Title: TWO-DIMENSIONAL ARRAY TRANSDUCER AND BEAMFORMER



(57) Abstract

An acoustic array transducer capable of forming narrow dispersion, broadband or narrowband acoustic beam sets in two dimensions with a minimum aperture size. Concurrent yet independent electrical interfacing with array transducer elements allows simultaneous formation of multiple transmit and receive beams inclined within two planar orientations normal to the array face, while requiring a minimum amount of supporting circuitry. A method of economically and accurately fabricating the aforementioned transducer array by incrementally dicing bonded layers of solid discs of transducer materials being rigidly held together is also disclosed.

**FOR THE PURPOSES OF INFORMATION ONLY**

Codes used to identify States party to the PCT on the front pages of pamphlets publishing international applications under the PCT.

AL	Albania	ES	Spain	LS	Lesotho	SI	Slovenia
AM	Armenia	FI	Finland	LT	Lithuania	SK	Slovakia
AT	Austria	FR	France	LU	Luxembourg	SN	Senegal
AU	Australia	GA	Gabon	LV	Latvia	SZ	Swaziland
AZ	Azerbaijan	GB	United Kingdom	MC	Monaco	TD	Chad
BA	Bosnia and Herzegovina	GE	Georgia	MD	Republic of Moldova	TG	Togo
BB	Barbados	GH	Ghana	MG	Madagascar	TJ	Tajikistan
BE	Belgium	GN	Guinea	MK	The former Yugoslav Republic of Macedonia	TM	Turkmenistan
BF	Burkina Faso	GR	Greece	ML	Mali	TR	Turkey
BG	Bulgaria	HU	Hungary	MN	Mongolia	TT	Trinidad and Tobago
BJ	Benin	IE	Ireland	MR	Mauritania	UA	Ukraine
BR	Brazil	IL	Israel	MW	Malawi	UG	Uganda
BY	Belarus	IS	Iceland	MX	Mexico	US	United States of America
CA	Canada	IT	Italy	NE	Niger	UZ	Uzbekistan
CF	Central African Republic	JP	Japan	NL	Netherlands	VN	Viet Nam
CG	Congo	KE	Kenya	NO	Norway	YU	Yugoslavia
CH	Switzerland	KG	Kyrgyzstan	NZ	New Zealand	ZW	Zimbabwe
CI	Côte d'Ivoire	KP	Democratic People's Republic of Korea	PL	Poland		
CM	Cameroon	KR	Republic of Korea	PT	Portugal		
CN	China	KZ	Kazakstan	RO	Romania		
CU	Cuba	LC	Saint Lucia	RU	Russian Federation		
CZ	Czech Republic	LI	Liechtenstein	SD	Sudan		
DE	Germany	LK	Sri Lanka	SE	Sweden		
DK	Denmark	LR	Liberia	SG	Singapore		
EE	Estonia						

**TWO-DIMENSIONAL ARRAY TRANSDUCER AND BEAMFORMER**Background of the Invention5           **1. Field of the Invention**

The present invention relates to a planar array sonar transducer which simultaneously forms multiple, narrow dispersion acoustic beam sets in two planar dimensions normal to the array face.

10           **2. Description of Related Technology**

Transducers which simultaneously generate multiple narrow acoustic beams inclined outward in two axes from a plane are currently used in different types of acoustic backscatter systems that measure velocity and/or distance in two or three dimensions. Examples include Acoustic Doppler Velocity Sensors (ADVS) which employ a simple set of four beams in a "Janus" configuration for two or three axis velocity measurement, sonars which measure distance to target in the water (such as forward scanning sonars), and bottom mapping sonars.

ADVS's are widely used for measurement of vertical profiles of water current measurements and for earth and/or water referenced velocity measurement for vessel navigation. They measure 3-axis velocities by measuring velocity along lines of position defined by narrow acoustic beams. A minimum of three beams oriented at different directions are required to measure the three orthogonal velocity components. Typically four narrow (1-4°) conical transmit/receive beams are employed positioned in two axes of a plane surface and inclined relative to the normal to that plane. This configuration, well known in the acoustic arts, is referred to as a Janus configuration; the two sets of narrow conical beams are symmetrically inclined outward and positioned at four 90° circumferential increments on the surface of a larger (typically 60°) outward opening cone. Currently available transducer technology used to produce this four beam configuration include assemblies of 4-piston transducers or a pair of one-dimensional phased array transducers (i.e., arrays in which acoustic beams are formed in one plane only).

Conventional 4-piston transducer assemblies consist of four independent circular piston-type transducers, each producing a single narrowly dispersed conical transmit/receive beam directed normal to the piston face. As shown in Fig. 1, the four transducers are physically positioned in a rigid assembly to achieve the required Janus beam configuration. For conventional narrowband ADVS applications, each of these transducers requires an effective transmit and receive bandwidth of approximately 2% of the nominal acoustic carrier frequency. Typical carrier frequencies range from 100 kHz to 5 MHz. Each piston transducer is typically fabricated from either a single solid disc of ceramic material or from a flat array of small ceramic elements. Modern broadband ADVS's operate with fractional bandwidths on the order of 50%. They are also fabricated from solid ceramic discs or flat arrays, but



have one or more additional impedance matching layers bonded to the face to achieve the required bandwidth. U.S. Patent No. 5,343,443, "Broadband Acoustic Transducer", discloses such a system. The primary advantage of this 4-piston method is simplicity of the transducer construction and operation. Each piston transducer is driven by a separate signal, and no beamformer circuitry is required.

5

Single beam transducers such as those previously described may also be beamforming arrays. These arrays generally have all of the transducer elements electrically connected in parallel. Beam angle alignment is achieved primarily by virtue of proper positioning of the piston. Disadvantages associated with such arrays include 1) the requirement for a large, heavy mechanical structure to support the transducers; 2) the shape of its face, whether concave or convex, does not lend itself to a smooth hydrodynamic form unless a thick, acoustically transparent material with a flat face is attached to the front portion of the assembly; 3) a large aperture is required to form the beams; and 4) accurate measurement of velocity requires that the speed of sound at the transducer face be known.

10

15

An improved transducer physical configuration for producing the four Janus configuration beams in 2 axes for ADVS applications is to use a pair of one-dimensional phased array transducers. As shown in Fig. 2, a single one-dimensional planar array produces two conical beams inclined relative to the direction perpendicular to the longitudinal axis of the array (see U.S. Patent No. 4,641,291, "Phased Array Doppler Sonar Transducer"). To produce the four ADVS beams, two adjacently positioned arrays are used, with one rotated 90° relative to the other about the aforementioned perpendicular direction. Since each one-dimensional array utilizes a single aperture, which is only slightly larger than a single beam piston, to produce two beams, a factor of approximately two improvement in aperture spatial efficiency is realized relative to the multiple piston approach.

20

25

One-dimensional phased arrays are typically constructed with parallel line arrays separated by a half wavelength of the carrier frequency. Each line array may be constructed using a number of small-square or circular ceramic elements wired in parallel on both faces, or from a singular, elongated rectangular element. Alternate line arrays are wired together electrically in parallel to provide the necessary beamforming functions. One such wiring arrangement involves electrically connecting each fourth line array in parallel. Both circular and rectangular array geometries are used. To produce a beam dispersion of 4° required for a typical ADVS, an aperture of about 16 wavelengths (32 elements spaced at 1/2 wavelengths) in diameter is required. For typical ADVS operating frequencies in the range of 100 kHz to 5 MHz (single piece commercially available line elements normally operate in this region), an array of 32 parallel long elements is preferred over a 32 X 32 diced array (i.e., one which is cut or diced from a single solid element) due to production assembly cost advantages.

30

35

When the array is operating in the "receive" mode (i.e., receiving incoming signals), a simple phase shift beamformer is used to phase shift the signals received by the two arrays (assuming the configuration previously

described) by  $\pm 90^\circ$  to compensate for the time delay produced by acoustic propagation over the half wavelength path length in the medium between alternate line arrays. A phase shift is an approximation to time delay which is valid only for narrow fractional bandwidth signals. For narrowband signals, the summation process forms two receive beams inclined to the flat array plane surface. When operating in the "transmit" mode, the two arrays are driven by narrowband signals with appropriate relative phase shifts to form the four (two per array) simultaneously transmitted beams.

When these phased arrays are driven by wideband signals, the different frequencies contained in the signals are dispersed from the transducers in different angular directions, effectively broadening the beams. The phased array technique forms narrow beams only when signal bandwidths are less than about 3%. This is adequate for narrowband ADVS applications, but falls short of the bandwidth associated with modern broadband ADVS systems by a factor of roughly between 8 and 16 (see, for example, U.S. Patent No. 5,483,499, "Broadband Acoustic Doppler Current Profiler").

An improvement in bandwidth/dispersion performance can be obtained for the pair of one-dimensional phased array transducers previously described by replacing the simple  $90^\circ$  phase shifting beamformer network (in both transmit and receive modes) with a more complex time-delay network. Use of the time delay decouples frequency from the relative angle of incidence of the received/transmitted wave, thereby reducing angular beam spreading in large bandwidth applications. With this time-delay array method, each of the individual line array signals are time delayed and summed together to form a composite signal which is independent of the angle of incidence. The primary drawback associated with this technique is the more complex transmit and receive beamformer.

An added performance benefit of the phased and time-delay array approach is that, for the ADVS application, the velocity components parallel to the array face are inherently self-correcting for changes in the speed of sound through the medium. As the speed of sound varies, differential path lengths and the corresponding time delays associated with various array transducers will vary accordingly. Self-correction results from the fact that the beam angle varies with the speed of sound in such a way as to directly compensate for errors in computing the velocity component parallel to the transducer face (usually horizontal). This minimizes, but does not completely eliminate, the need to measure sound velocity at the transducer face for high accuracy navigation.

Thus, relative to 4-piston assemblies, one-dimensional phased arrays provide improved spatial efficiency for fixed beam characteristics, have a flat face for better hydrodynamic performance, and have improved velocity resolution in media with varying sound propagation velocities, yet do not adequately support broadband ADVS operation. One-dimensional time-delay arrays have the added benefit of supporting broadband ADVS operation as well.

One-dimensional phased and time-delay array techniques are also commonly used for bottom mapping and forward scanning applications to form more than two beams within a single plane of the array face. For these applications, multiple phase and/or time-delay beamformers are coupled to a single one-dimensional array, each beamformer having different phase/time-delays to simultaneously form multiple beams at different angles of inclination relative to the array face, but all within a single planar orientation perpendicular to the array face. If measurement in a second planar orientation is required, two adjacent one-dimensional phase or time-delay arrays are used, with one physically rotated 90° from the other as previously described.

For each of the above mentioned techniques of forming multiple acoustic beams inclined within two planes perpendicular to the array face plane, an aperture of at least twice the size of that required to form any single narrow beam is necessary. It is possible to form two or more conical beams within two planes perpendicular to the array face if the proper signal can be provided to each element of the array. The formation of four beams in two perpendicular planes from a single planar array is depicted in Fig. 3. It is well understood in the art that such planar arrays can form beams centered around arbitrary angles relative to the array face if appropriate phase shifts are introduced between individual transducer elements; this concept has been in use for many years in radar antenna arrays and to a lesser extent in sonar transducer arrays. It is also well understood that beam forming for wide bandwidth applications requires true time delays between elements to compensate for the time delays produced by propagation over different path lengths in the medium associated with different elements.

A substantial reduction in the size, weight, and cost of the ADVS transducer assembly could be achieved if four inclined beams oriented in two planes perpendicular to the array face could be formed from a single planar array of transducer elements, using the full available aperture to form all beams, as shown in Fig. 3. To accomplish this, a 32 x 32 array of about 800 elements is required, with the array elements precisely aligned at 1/2 wavelength increments in both plane face dimensions, i.e., with respect to the X-Y coordinate system of Fig. 2. Assembly of this precision array from 800 individual elements is relatively complex. Complex phase and/or time-delay circuitry is also required to support beamforming in two dimensions for this large number of elements. Using existing array technology, a separate power amplifier and phase and/or time-delay circuit would generally be required for each individual element of the array. These array fabrication and beamformer complexity factors make the use of a two dimensional planar array an economically impractical solution for nearly all applications.

Hence, it would be highly desirable to provide an improved planar array which could produce narrow dispersion beam sets in two dimensions relative to the array face within a substantially reduced aperture, and which would utilize simplified phase and/or time-delay beamforming circuitry to support the large number of individual transducer elements inherent in such arrays. Furthermore, it would be highly desirable to provide an efficient and cost-effective method of fabricating the aforementioned array to make its manufacture and use economically practical.

Summary of the Invention

The present invention satisfies the aforementioned needs by providing an improved system and method of forming a multi-planar narrowband or broadband beam set inclined relative to a transducer array face, with reduced aperture area. A cost effective and simplified method for manufacturing the transducer array is also disclosed.

In a first aspect of the invention, each 2-axis beam set formed from the single 2-axis planar array of transducer elements uses all of the elements in the array and the full available aperture to form each of the beams. From an aperture spatial efficiency viewpoint, this is an optimal approach to forming multiple narrow 2-axis beams, because each beam can be made as narrow as allowed by the available aperture area. The overall aperture area will be minimized for a given beamwidth of each of the multiple 2-axis beams. Relative to the previously described 4-piston approach, the aperture diameter is reduced by a factor of 2.5, (a factor of 6 for the area), the transducer face is substantially more hydrodynamic (thereby reducing flow resistance, noise, and potential inaccuracies resulting from air coalescing near the aperture), and the transducer assembly volume is reduced by a factor of roughly 10. Relative to the previously described dual 1-dimensional array approach, the aperture area is reduced by a factor of two.

In a second aspect of the invention, the multi-planar (2 axis) array disclosed herein utilizes a greatly reduced number of phase or time-delay beamforming circuits relative to the number of elements in the array. The capability to produce multiple narrow beams in two axes from a single planar array is achieved by a method of electrically interfacing independently with the two sides of the array permitting independent and simultaneous formation of multiple inclined transmit and receive beams in two dimensions of the array plane. This is accomplished by electrically connecting together the backside rows and frontside columns of the array, connecting the backside and frontside parallel sets to beamformer networks which have a low electrical impedance (relative to the impedance of the rows and columns) in both the transmit and receive mode of operation, and processing the transmit/receive signals to/from the two array sides to simultaneously and independently form multiple inclined transmit/receive beams in two dimensions of the array plane. The two directions are normally but not necessarily orthogonal to each other.

In another aspect of the invention, a cost effective method of fabricating the planar array of approximately 800 precisely aligned elements is disclosed. While, as previously described, prior art one-dimensional multibeam arrays may be fabricated from an array of on the order of 32 long rectangular transducer elements of about 1/2 wavelength in width, the preferred embodiment of the present invention requires the use of array elements which have dimensions of approximately 1/2 wavelength of carrier frequency in both face dimensions. Furthermore to achieve the necessary bandwidth for broadband applications, each element must be constructed of several layers of different materials which must be bonded together. Hence, an array of roughly 800 multi-layered elements (32 x 32) is required to be precisely assembled in a cost effective manner to make the aforementioned design economically

feasible. To accomplish this, an improved method of fabricating this complex array is disclosed in which several cylindrical discs (each having a diameter equal to that of the final array) are sequentially bonded together and partially sliced with a parallel diamond blade saw at various stages of the process such that at all stages of fabrication, the sliced elements are rigidly held together by a solid layer. When completed, the array is internally dived into the desired form with the required precision, and held in shape by the combination of a mechanically rigid and acoustically transparent front facing and a solid backing disc.

The aforementioned simplified design and fabrication techniques make it economically practical to produce cost effective commercial products with the form and performance advantages of the 2-dimensional flat array. The present invention provides significantly improved performance for typical ADVS (i.e. a four beam 150 kHz transducer with 4° one-way beamwidths) applications. These and other objects and features of the present invention will become more fully apparent from the following description and appended claims taken in conjunction with the following drawings.

#### Brief Description of the Drawings

Fig. 1 is a top view of a prior art 4-piston transducer array in Janus configuration.

Fig. 2 is a perspective view of a prior art one-dimensional phased acoustic array, illustrating the formation of two narrow acoustic beams.

Fig. 3 is a perspective view illustrating a typical configuration of four acoustic beams inclined relative to the array normal (i.e., Z-axis) and positioned within two planes perpendicular to the array face plane (i.e., X-Y plane).

Fig. 4 a functional block diagram of the preferred embodiment of the two-dimensional transducer array, including the method of electrical array element interconnection, and the method of array-to-beamformer interconnection to the transmit and receive beamformers.

Fig. 5 is a functional block diagram illustrating the operation of a simplified sixteen element 2-dimensional phased array transducer operating in the receive mode.

Fig. 6 is a functional block diagram illustrating the operation of a simplified sixteen element 2-dimensional phased array transducer operating in the transmit mode.

Fig. 7 is a functional block diagram illustrating the operation of a simplified sixteen element 2-dimensional time-delay transducer operating in the receive mode.

Fig. 8 is a functional block diagram illustrating the operation of a simplified sixteen element 2-dimensional time-delay transducer operating in the transmit mode.

Fig. 9 is a perspective view illustrating the formation of multiple beams in two planes perpendicular to the face of an array using the time-delay technique.

Fig. 10 is a top view of one preferred circular 150 kHz transducer array with 800 individual square faced piezo-electrical ceramic elements closely spaced at a center-to-center distance of 5mm.

Fig. 11 is a perspective view of one preferred embodiment of the transducer assembly with the thickness dimension expanded to illustrate the layered construction thereof.

Fig. 12 is a schematic block diagram of one preferred embodiment of the time-delay receive beamformer used in conjunction with the present invention.

5 Fig. 13 is a schematic block diagram of one preferred embodiment of the time-delay transmit beamformer used in conjunction with the present invention.

Fig. 14 is a graph of signal amplitude versus beam angle (measured from the Z-axis, normal to the array face) for a 150 kHz nominal 32 x 32 phased array transducer, as viewed in the X-Z or Y-Z planes, illustrating the formation of acoustic one beam.

10 Fig. 15 is a process diagram illustrating the preferred manufacturing process for fabricating the preferred array transducer of the present invention.

#### Detailed Description of the Preferred Embodiment

15 Reference is now made to the drawings wherein like numerals refer to like parts throughout. The discussion in this section is organized with headings as follows: Functional Description, Hardware Description and Fabrication Description.

#### 20 1. Functional Description:

A block diagram of the preferred embodiment of the two-dimensional transducer array is shown in Fig. 4. A typical planar acoustic transducer array configuration 100 is depicted. Individual Array elements 102 are electrically interconnected along front-side columns 104 and back-side rows 106. Array elements 102 are interconnected to the associated beamformer 108, 110 through 2-axis transmit/receive (T/R) switches 118. The  
25 transmit 108 and receive 110 beamformers may be either phase or time-delay beamforming networks. The coordinate system used for the purposes of this description is as shown with the rows 106 oriented in the X axis, columns 104 in the Y axis, and the Z axis normal to the plane face 116.

The array face 116 is circular, but other form factors such as ellipses or polygons which are generally  
30 symmetrical in the two face dimensions are also suitable for forming narrow inclined beams of general conical form. The array is composed of a large number of small elements 102 which have symmetrical faces, typically square, circular, or rectangular in form (i.e., their facial cross-section). The face width of each element is approximately  $0.5\lambda$ , where  $\lambda$  is the acoustic wavelength in water of the desired center frequency. To form beams with  $4^\circ$  beam width, an array diameter of approximately  $16\lambda$  is required, consisting of a 32 X 32 element array of approximately 800  
35 elements. The back side rows 106 (X direction) and front side columns 104 (Y direction) of the array elements are

electrically connected together along parallel lines of elements with thin acoustically transparent material, as shown in Fig. 4. The rows and columns are normally but not necessarily orthogonal to each other.

Each of the array X axis rows 106 and Y axis columns 104 are connected to a T/R switch 118 which, as controlled by a T/R logic signal 120, electrically connects the sets of X and Y lines to respective X and Y receive beamformers 110 in the receive mode, and to X and Y transmit beamformers 108 in the transmit mode. When in the transmit mode, the array lines are connected through the T/R switch 118 to the transmit beamformers 108 which provide the electrical transmit drive signals from a low impedance electrical source (relative to the electrical impedance of the line of transducer elements). When in the receive mode, the array lines are connected through the T/R switch to receive beamformers 110 which receive the electrical signals from the transducer lines while providing a low electrical impedance path (relative to the electrical impedance of the line of transducer elements) to signal ground on each X and Y line.

This low electrical source/load impedance on each X and Y line (low source impedance during transmit and low load impedance during receive) allows simultaneous and independent access to each X row 106 and Y column 104 for application of transmit electrical drive signals and receipt of signals from each X row and Y column. Furthermore, parallel sets of X and Y axis line arrays can be simultaneously and independently formed. X-axis transmit and receive line arrays are formed by the parallel electrical connection along the back side rows 106 and the presence of the low impedance signal ground on all of the front side Y-axis columns 104.

During transmit mode, transmit drive signals are applied through the T/R switch to the parallel X-axis back side electrical interconnection lines from a transmit amplifier which has a low output impedance relative to signal ground. While the X-axis drive signals are being applied to individual X-axis line arrays, the entire Y-axis 32 parallel line array face is maintained as a low impedance path to signal ground (via the signal path through the Y-axis T/R switch 118a to the low impedance Y-axis drivers of the Y beamformer 108a) to ensure that the X-axis drive signal is imposed solely across the X-axis rows, and does not couple to the Y-axis side of the array. Similarly, while the Y-axis drive signals are being applied to Y-axis line arrays, the entire X-axis array face is maintained as a low impedance path to signal ground to allow signals to be independently applied the Y-axis without coupling to the X-axis. Thus, by superposition of both X and Y axis transmit drive signals, the low impedance associated with the transmit beamformer sources permits X- and Y-axis line transmit arrays to be formed simultaneously and independently.

During receive mode, the electrical signal present on each X-axis row 106 (with the front side low impedance path to signal ground) represents the sum of the received electrical signals of all elements in each row. Most conventional sonar receiver amplifiers provide a high impedance load to the receiving transducer. However, for the 2-dimensional array application of the present invention, an amplifier has been developed for use in the receiving

beamformer which provides a low impedance load while receiving. This is accomplished by connecting each of the X and Y-axis lines to a virtual ground node (a point having the same potential level as ground but not directly connected to ground) on the receiving preamplifier within the receive beamformers. The signal current flowing into each virtual ground node is the sum of the signal currents from all the ceramic elements in the column or row.

5 When receiving signals from a column, the column signal is independent of the row signals being simultaneously received due to the low impedance load presented by the virtual ground on all rows. Similarly, when receiving signals from row, because of the low impedance load presented by the virtual ground on all columns, this row signal is independent of the column signals being simultaneously received.

10 This independent and simultaneous X row and Y column electrical access during both transmit and receive modes via the X and Y signal lines allows the array to be used as a 2-dimensional array to simultaneously and independently form multiple inclined acoustic beam set in both the X-Z and Y-Z planes. The beamforming operation in each plane is the same as conventional 1-dimensional phased and/or time-delay arrays. Thus, the 2-dimensional beamforming operation is in general the equivalent of two overlaid 1-dimensional arrays, with one array rotated 90°.

15 During transmit mode operation, phase or time-delayed signals applied to the X rows form inclined acoustic transmit beams in the Y direction (YZ plane). Simultaneously and independently, phase or time-delayed signals applied to the Y columns to produce inclined acoustic transmit beams in the X direction (XZ plane). During receive mode operation electrical signals received on the X rows are phase or time delayed and combined in the X row receiver beamformer to produce inclined receive acoustic beams in the Y direction. Simultaneously and independently, signals received on the Y columns and combined in the Y side beamformer produce inclined receive acoustic beams in the X direction. Thus, through superposition of the X and Y axis electrical and acoustic signals, 2-dimensional acoustic beam formation from a single planar array in both transmit and receive modes is achieved.

20 To understand the fundamental principles of operation how these two-dimensional transmit and receive acoustic beams are formed, the operation of sixteen element array subset of the 32 X 32 element two-dimensional array transducer is considered. Operation with both phase (narrowband) and time-delay (narrowband or broadband) beamformers is described herein.

### 30 *Phased Array Operation*

Operation of a sixteen-element (4 X 4) subset of the previously described two-dimensional array with a phase-shift beamformer is illustrated in Figs. 5 and 6. During receipt of a long tone burst acoustic signal at a single frequency (narrowband),  $f$ , with wavelength,  $\lambda = c/f$ , where  $c$  is the sound propagation velocity in the fluid media, incoming sound ray wavefronts 200 traveling in the -X direction and at an angle  $\theta$  202 with the Z axis (Z being normal to the array plane, or normal to the plane of the Figure) travel different distances to each of the Y-axis (frontside) column line-arrays 204, and thus strike each of the line arrays at different times, and in general, with



different phases. As illustrated in Fig. 5, the path length differences between adjacent line-arrays ( $\alpha$ ) 206 is related to the element center-to-center separation distance ( $d$ ) by

$$\alpha = d \sin\theta.$$

5

The wavefront arrival time differences ( $\tau$ ) between adjacent line-arrays is

$$\tau = \alpha/c = (d/c)\sin\theta$$

10 If the elements are spaced at distances corresponding to a half-wavelength of the arriving narrowband signal ( $d = \lambda/2$ ), the path length difference expressed in terms of arriving signal wavelengths is given by

$$\alpha = (\lambda/2)\sin\theta.$$

For an arrival angle of  $30^\circ$ ,

15

$$\alpha = (\lambda/2)\sin 30 = \lambda/4.$$

This corresponds to an inter-element angular phase shift of  $90^\circ$  for arriving narrowband signals. Thus, when the narrowband pulse is being received by all Y-axis line-arrays with the backside coupled to the low impedance virtual grounds 208 as described above, the received electrical signal phases along the set of four Y-axis line-arrays will be 0, 90, 180, and 270 degrees, respectively.

20

Receive operation of the frontside (Y) columns with the backside rows 106 all coupled to signal ground in the X-axis receive beamformer 110b will first be considered. Each set of four X-axis electrical signals (in the 4x4 array used for illustration) are connected to virtual ground nodes 208 in the receiver preamplifier of the receive beamformer 110a to form a signal reference for the backside rows, and phase shifted  $-90^\circ$  between adjacent line-arrays (0,  $-90$ ,  $-180$ , and  $-270$  degrees), as shown. The imposed phase shifts compensate for those arising from the different inter-element path lengths of the narrowband acoustic pulse incident on the line arrays, as illustrated in Fig. 5. The resulting four signals 210 will be in phase and, when summed, will form a maximum acoustic interference pattern when receiving a wavefront arriving at a  $30^\circ$  incidence angle. This maximum corresponds to the central axis of one of the main lobes of the formed beams.

25

30

A second receive beam can be formed for incoming sound ray wavefronts traveling in the  $-X$  direction and at an angle  $\theta$  with the Z direction (at a  $-30^\circ$  incidence angle) by reversing the sign of the  $90^\circ$  imposed phase shift on the four signals and summing the signals. Since the set of four signal phases repeats for additional sets of four line-arrays, larger arrays can be implemented by summing the signals from all sets of four line-arrays to further enhance the interference patterns at  $\pm 30^\circ$ . When additional sets of four line-array segments are utilized as

35

described, the acoustic signal gain along the  $\pm 30^\circ$  directions is increased, or correspondingly, the beamwidth in that direction is reduced, as additional sets of arrays are added.

5 An equivalent beamforming method is to first sum all of the equal phase signals from different array sets, then apply the imposed  $90^\circ$  phase shifts between the summed set of four signals. This can be accomplished by simply electrically connecting each fourth line-array in parallel, as is commonly done in practice for one-dimensional phased arrays as previously described (see Fig. 2). The effective beamwidth in the X direction is determined by the number of line-array sets in the array. In the Y direction, the beamwidth is determined by the beam patterns of the line-arrays, which is inversely proportional to the length (in acoustic wavelengths) of the array lines. For the ADVS  
10 application, narrow inclined acoustic beams with similar widths in both planes are desired and the X and Y plane dimensions are maintained about the same.

During the transmit mode, operation of the 2-axis array is similar to the above described receive mode except the flow of signals is reversed, as illustrated in Fig. 6. Transmit operation of the frontside columns with the  
15 backside rows all coupled to signal ground will first be considered. A long tone burst carrier frequency 300 is applied to a phase shift transmit beamformer 108a, generating four drive signals with relative phases of 0,  $90^\circ$ ,  $180^\circ$  and  $270^\circ$  degrees. These are applied to the four parallel wired sets 302 of Y columns from low impedance drivers. The imposed phase shifts will compensate for those arising from the different path lengths between line arrays, and a transmitted acoustic signal interference pattern at a  $30^\circ$  incidence angle will be formed, corresponding to the  
20 center of one of the main beam lobes. Another transmitted beam can be formed at a  $-30^\circ$  incidence angle by reversing the sign of the  $90^\circ$  imposed phase shift as previously described.

Receive and transmit operation in the Y-axis is the same. When considering signals applied and received from the backside rows, the frontside columns are coupled through a low impedance to signal ground. The presence  
25 of the low transmit drive and receiver load impedance to ground on each side results in fully independent X and Y axis operation. From superposition of the X and Y axis signals, it can also be seen that both axes (i.e., rows and columns) can be in operation simultaneously.

The above described 2-axis beamforming technique using fixed phase delays in forming narrow transmit and receive beams and is referred to as a "two-dimensional phased array" transducer. It is suitable for use in  
30 narrowband applications which transmit a single frequency (narrowband) long tone burst. Four inclined narrow beams positioned in the X-Z and Y-Z planes and all inclined at an angle relative to the Z direction are formed from a single flat array aperture, as shown in Fig. 3.

From the sound ray diagram in Fig. 5, it is seen that for a fixed element spacing of  $d$ , the angle of each  
35 beam is related to the acoustic frequency by

$$\theta = \sin^{-1}(\lambda/4d) = \sin^{-1}(c/4fd).$$

Thus, the beam angle will be frequency dependent and, if the incoming or outgoing wave has a broad spectrum, the mainlobe beam pattern will be correspondingly broadened in angular space. Because of this bandwidth induced beam spreading, the phased array technique described above does not work with broadband ADVS's which transmit signals with a broad spectrum (typically 20-50% of the carrier frequency). To use this 2-dimensional array method with broadband signals requires an alternate time-delay beamforming method, as described in the following paragraphs.

*Time delay Array operation:*

As previously shown, incoming sound ray wavefronts traveling in the -X direction at a velocity c and at an angle  $\theta$  with the Z direction, strike the various Y-axis front side column line-array locations at different times due to the path length differences between adjacent line-arrays. The path length distance difference,  $\alpha$ , was shown to be equal to  $d \sin\theta$ . The corresponding path length time delay difference ( $\tau$ ) is  $(d \sin\theta)/c$ . While the phased array employs a beamformer which compensates for the inter-element phase delays which apply only for narrowband signals, the time delay array employs a beamformer which compensates for the inter-element time delays which apply for signals of broader frequency band.

Considering now the receive mode of operation of a 4 X 4 array subset as illustrated in Fig. 7, with the backside rows connected to virtual ground in the X-axis receive beamformer 110b, each set of four Y-axis electrical received signals are connected to virtual ground nodes in the receiver beamformer amplifiers 402 to form a signal reference for the backside rows. The amplifier outputs are applied to a tapped bidirectional time-delay summing network 404 as shown in Fig. 7. The imposed inter-element electrical time delay 406,  $\tau$ , compensates for the time delay arising from the different inter-element path lengths of the arriving acoustic signals, resulting in formation of two beams in the  $\pm$  X-axis (X-Z plane) at incidence angles of

$$\theta = \sin^{-1}(c\tau/d).$$

By inspection of this equation, it can be appreciated that the beam angles are now independent of the acoustic frequency, and thus not spatially broadened in space by a broad frequency spectrum. This broadband capability is the primary benefit of the time-delay technique over the previously described phase shift technique.

During the transmit mode, operation of the 4 X 4 array is similar to the above described receive mode except the flow of signals is reversed as illustrated in Fig. 8. Considering first the operation of the frontside columns with the backside rows all coupled to signal ground in the X-axis beamformer 500, the transmit signal 502 is applied to a time delay transmit beamformer 504, generating four drive signals with relative time delays 508 of 0,  $\tau$ ,  $2\tau$ , and  $3\tau$ . These are applied to the four parallel wired sets 506 of Y columns from low output impedance drivers.

The imposed time delays compensate for the time delays arising from the different path lengths between line arrays, and a transmitted acoustic signal interference pattern at an incidence angle  $\theta$  will be formed, corresponding to the center of one of the main beam lobes. Another transmitted beam can be formed at a  $-\theta$  incidence angle by reversing the direction of the signal flow through the time delay network.

5

Time-delay array receive and transmit operation in the other dimension (Y-axis) is completely analogous to that previously described. In Y-axis operation, signals are applied to and received from the backside rows while the frontside columns are coupled through a low impedance to signal ground. The presence of the low transmit drive and receiver load impedance to signal ground on each side results in complete independence of X and Y axis operation; accordingly, both X and Y axes can be in operation simultaneously.

10

For large arrays, the aforementioned time-delay method is more complex to implement than the phase shift method because a separate time delay element is required between each individual line-array, whereas only four discrete phase shifts are required when utilizing the phase shift method. A 32 element time delay network is required for a 32 element array, thereby substantially increasing the complexity of a time delay array over a corresponding phased array of similar size. A further advantage of the time delay approach (in addition to the ability to form narrow beams in broadband operating environments) is that because the beam angle  $\theta$  is determined by  $\sin^{-1}(c\tau/d)$  for a single fixed array physical configuration (element spacing  $d$  being fixed), multiple inclined beams in each axis can easily be formed by using a different set of time delays for each beam set. This concept is illustrated in Fig. 9. In this example, four sets of 4-beam combinations 550 oriented symmetrically about the Z axis 552 at four inclination angles  $\theta$  are achieved by utilizing four sets of X and Y beamformers (BF1X - BF4X 554 and BF1Y - BF4Y 556), each set operating as described above for the basic time-delay array.

15

20

## 2. Hardware Description

As can be appreciated from the previous description, the present invention may be embodied to produce many combinations of 2-axis inclined beams with different carrier frequency, beam characteristics and signal bandwidth capabilities. The specific preferred hardware embodiment described in this section employs the time-delay beamformer which was functionally described in the previous section, and produces two narrow bandwidth broadband beams at a 150 kHz carrier frequency in each of two axes for use in ADVS applications.

25

30

The hardware associated with the preferred embodiment disclosed herein is comprised of a circular transducer array and two substantially identical beamforming networks, each of which provide the electrical signal transfer to form two inclined transmit/receive beams. A top view of the transducer array is provided in Fig. 10. The diameter D 600 of the array is approximately 160 mm. There are 800 individual square faced 150 kHz piezoelectrical ceramic elements 102 closely spaced at a center to center distance of 5 mm 604 (about 1/2 wavelength at 150 kHz, based on a propagation velocity of roughly 1500 m/s).

35

The multilayer construction of the transducer array is illustrated in the three dimensional view shown in Fig. 11. This thickness dimension in this view is expanded to show the layered structure. The ceramic array elements 700, e.g., the 800 elements 102 shown in Figure 10 are electrically and mechanically connected by two pieces of thin, acoustically transparent flexible printed circuits (FPC) 702, 704 on the top and bottom surfaces of the ceramics. Such circuits may be fabricated from Kapton™ (polyimide) or other suitable material. Electrical connection to each ceramic element 700 is achieved by press fitting and bonding (or alternatively, low temperature soldering) the printed electrical conductor lines to the conductive face of the array elements. Bonding may be accomplished by use of a suitable adhesive or glue, although it can be appreciated that other forms of bonding may also be suitable. The connection pattern is along element columns on the front side and along rows on the back side, with access to columns on one side (Y wires 705) and rows on another side (X wires 707). A piece of 1/8 inch (3.18 mm) thick fiberglass material 706 (such as that bearing the tradename "G-10" or other similar material) with face dimensions matching the ceramic is bonded to the front of the top flexible circuit on each 150 kHz transducer array. This fiberglass (G-10 or equivalent) piece is an acoustic quarter wave transformer used to improve the impedance coupling between the array and water, and to significantly increase the transducer element bandwidth. The significant increase in the transducer bandwidth is required by the broadband ADVS technology. A layer of urethane 708 bonded to the front of the fiberglass piece seals the face to the water in front. A layer of air filled cardboard 710 is placed between the back plane of the housing 712 and the back of the bottom flexible circuit to reflect the acoustic energy transmitted backward and to provide the necessary mechanical support against the water pressure incident on the front of the transducer array surface 714.

The preferred time-delay receive mode beamformer circuitry (one axis only) is illustrated in Fig. 12. In the receive mode of operation, the received signals from all frontside columns and backside rows 104, 106 are coupled to the X and Y axis beamformers 110a, 110b, respectively, through T/R switches 118. Each T/R switch is implemented with a Field Effect Transistor (FET) 806 in series with the receiver amplifier input terminals 808. A virtual ground low impedance load on all X and Y lines during receive mode operation is implemented with a high gain differential preamplifier 810 which has a low noise figure when coupled to the relatively low impedance transducer line arrays. Each X and Y transducer line array is connected to the negative terminal of the high input impedance differential amplifier, the positive terminal is connected to signal ground 812, and a feedback impedance 814 is connected between the low impedance preamplifier output and the negative input terminal. This forms a well known inverting operational amplifier configuration (the resulting gain of the amplifier is proportional to the negative of the ratio of the feedback impedance to source impedance 816) with the transducer line array providing the input signal with a source impedance 816 equal to the electrical impedance of the line array. If the amplifier open loop gain is much higher than the closed loop gain determined by the ratio of the feedback resistor to the source impedance of each 150 kHz line array ( $\approx 200$  ohms), the voltage across the input terminals will be small with respect to the received signal. Since the positive amplifier terminal is grounded, the negative terminal is maintained by the amplifier

loop action at essentially ground potential also. Thus, the negative terminal input 808 is considered a "virtual" ground.

The output of the preamplifier is converted to a high output impedance current source via a transistor 818  
5 which injects the signal current derived from the line array into a tapped analog time-delay summing network 404. This network has 32 taps (corresponding to each of the 32 rows or columns used in each dimension); each segment between the taps has a time delay of  $t$  microseconds, corresponding to the delay required to compensate for the  $t$  microsecond acoustic time delay occurring for arriving and departing signals at the line arrays at the chosen angle of incidence. Each time-delay segment is implemented with a four-component inductor/capacitor network 822 which  
10 approximates a second order all-pass filter. This inductor/capacitor network provides an approximation of a wide bandwidth time delay which is accurate to 0.1% over a 25% bandwidth.

The above description applies to the receive beamformer associated with one of the two axes of a 2-axis array. It can be appreciated that a corresponding set of receive beamformer electrical hardware is utilized for  
15 processing the receive signals for the other axis.

Fig. 13 shows the preferred time-delay transmit beamformer (one axis only) associated with the present invention. The transmit beamformer time delays are achieved with digital circuits and square waveforms to simplify the circuits and achieve precise time delays determined by an accurate clock signal. TB1 and TB2 850 are square  
20 waveforms at the frequency to be transmitted by the four acoustic beams. For each of the 32 rows, TB1 and TB2 are summed together by summing circuits 851 after an appropriate time delay (achieved through use of 32 bit shift registers 852) and applied to the 32 array rows through the transmit amplifiers 854. Harmonics associated with the square wave output signals of the transmit amplifiers are attenuated by the bandpass characteristics of the transducer array row or column 856; the transmitted signal is therefore dominated by the fundamental transmit  
25 frequency. The transmit amplifiers are implemented with low impedance FET push/pull output stages 858 which have a low output impedance when driving the transducers. During receive mode operation, a high output impedance load is supplied by turning both push/pull stages off.

During the transmit mode, the electrical potential between the two faces of each ceramic element is  
30 determined by the summation of four appropriately delayed waveforms: the two row drive signals (TB1 and TB2) described above, and a corresponding set of time-delayed column drive signals (TB3 and TB4). Four inclined acoustic beams in 2 axes (X-Z and Y-Z planes) will be generated with these time delayed drive waveforms.

The time delay array forms four transmit and receive beams each with a  $4^\circ$  beam width (based on two  
35 side, 3 dB downpoints). Fig. 14 is a graph of signal amplitude versus beam angle (measured from the Z-axis, normal to the array face) for a 150 kHz nominal 32 x 32 phased array transducer, as viewed in the X-Z or Y-Z planes,

illustrating the formation of one acoustic beam 900. As shown, the sidelobe attenuation at the neighbor and opposite beam position ( $\pm 30$  degree beam angle, 904) is about -40 dB.

### 3. Fabrication Description:

5           Another aspect of the present invention relates to a unique method of manufacturing a transducer array suitable for use in such a multiple beam sonar in an economical manner, and which preserves the precise geometrical relationships among the elements. This method is described in detail in the following paragraphs.

10           For high frequency arrays as previously described, the diameter of the individual transducer elements and the distance between the individual transducer elements is small, e.g.,  $< 5$  mm, and a large number of precisely placed elements are required. Since it is not practical to assemble this many small individual elements into the array, the elements must remain in their original position during and after dicing, and must be electrically connected as previously described. Therefore, one cannot simply glue the ceramic element, fiberglass, acoustically transparent Flexible Printed Circuit (FPC), and backing material together and then cut it into the desired number of pieces. A  
15           reliable and economical method of manufacturing the 2-axis transducer array which preserves precise geometrical relationships among the elements is required.

          The preferred process used to manufacture the preferred embodiment of the present invention is illustrated in Fig. 15. The necessary components for assembly of the preferred transducer array include a cylindrical solid  
20           fiberglass element 706 (G-10 or equivalent), front side (Y-axis) Y FPC sheets 702, a cylindrical ceramic element 700, back side (X-axis) X FPC sheets 704, a cardboard backing layer 710, and a urethane layer 708. A cup housing may also be utilized to house the transducer array assembly when the fabrication process is completed. Note that other forms such as ellipses or polygons which are generally symmetrical in the two face dimensions are also suitable for use in lieu of the aforementioned cylindrical shapes.

25           The fabrication process generally involves use of a parallel blade diamond saw to slice through the front and back sides of a solid piece of ceramic and an attached impedance layer to create electrically and mechanically independent elements. This is done in such a way that all array elements are held in place during and after slicing to preserve precise geometrical relationships among the elements. Specifically, the disclosed process for  
30           manufacturing the preferred embodiment of the present invention is as follows, with reference being made to Fig. 15:

1.           First, a parallel blade diamond saw (not shown) is used to slice the front face of the fiberglass matching layer 706 halfway through its thickness, defined by the Z-axis, in the X and Y directions.
- 35           2.           Second, a layer of acoustically transparent urethane 708 is bonded to the front face of the fiberglass matching layer 706.

3. The diamond saw is then used to slice the back side of the fiberglass matching layer 706 through its remaining thickness in both the X and Y directions.

4. Next, the diamond saw is used to slice the back face of the transducer array blank 700 halfway through its thickness, defined by the Z axis, in the X and Y directions.

5 5. A thin layer of X-axis conducting foil (X FPC) 704 is then bonded on the back face of the blank 700.

6. A layer of backing material 710 is next bonded to the back face of the X-FPC 704.

7. The front face of the blank 700 is next sliced through its remaining thickness (Z direction) in the X and Y directions.

10 8. A thin layer of Y-axis conducting foil (Y FPC) 702 is then bonded on the front face of the ceramic/X FPC transducer assembly.

9. Finally, the sliced fiberglass matching layer/urethane assembly 706, 708 and ceramic/FPC/backing assembly 700, 702, 704, 710 are bonded together as shown.

15 A cup housing or other support element may subsequently be fitted as required to provide for mounting the transducer array to the desired platform (such as a ship hull or current profiler) and sealing against water intrusion. It can be appreciated that a large number of different housing designs and sealing mechanisms may be utilized in conjunction with the present invention to fulfill these needs.

20 While the above detailed description has shown, described, and pointed out the fundamental novel features of the invention as applied to various embodiments, it will be understood that various omissions, substitutions, and changes in the form and details of the device or process illustrated may be made by those skilled in the art without departing from the intent of the invention.

25



WHAT IS CLAIMED IS:

1. An acoustic system, comprising:  
a plurality of transducer elements arranged to form a single two-dimensional array, wherein the elements  
5 are electrically connected into rows in a first dimension and columns in a second dimension and the rows are electrically independent of the columns;  
a first beamforming circuit forming a first plane of acoustic beams projected outside of the array plane and substantially normal to the first transducer array dimension, the first beamforming circuit electrically connected to the transducer elements in the second transducer array dimension, wherein the first beamforming circuit delays  
10 signals associated, respectively, with each column; and  
a second beamforming circuit forming a first plane of acoustic beams projected outside of the array plane and substantially normal to the second transducer array dimension, the second beamforming circuit electrically connected to the transducer elements in the first array dimension, wherein the second beamforming circuit delays signals associated, respectively, with each row, the system thereby capable of forming at least two planes of  
15 acoustic beams.
2. The acoustic system of Claim 1, wherein the acoustic beams formed by the system are in the Janus configuration.
3. The acoustic system of Claim 1, wherein the transducer elements are arranged to substantially form a pattern selected from the group consisting of circular, elliptical or polygonal shapes.
- 20 4. The acoustic system of Claim 1, wherein the rows and columns are orthogonal to one another.
5. The acoustic system of Claim 1, wherein each transducer element has a facial crosssection selected from the group consisting of a circular, elliptical or polygonal shapes.
6. The acoustic system of Claim 1, wherein the transducer elements are arranged within the array such that the centerline-to-centerline distance between individual elements is one-half of the wavelength of the  
25 system acoustic carrier frequency as measured in water and at the front face of the array.
7. The acoustic system of Claim 1, wherein the first and second beamforming circuits include multiple bit shift registers.
8. The acoustic system of Claim 1, wherein each transducer element is symmetric in the facial plane.
9. The acoustic system of Claim 1, wherein the first and second beamforming circuits provide a  
30 virtual ground load impedance to all rows and columns, respectively when the system is receiving signals.
10. The acoustic system of Claim 1, wherein the first and second beamforming circuits provide a low source impedance to all rows and columns, respectively when the system is transmitting signals.
11. The acoustic system of Claim 1, wherein the rows and columns of transducer elements are electrically connected into P sets of elements by interconnecting each Pth row and column, the first and second  
35 beamforming circuits being electrically connected to these P sets of rows and columns, respectively.

12. An electro-acoustic transducer capable of forming multiple transmit or receive acoustic beams from a single planar aperture, comprising:

a plurality of transducer elements arranged in a planar array of N substantially parallel rows and M substantially parallel columns, each row of transducer elements being electrically connected along a first face of the array, and each column of transducer elements being electrically connected along a second face;

a first transmit/receive beamformer electrically connected to the rows;

a second transmit/receive beamformer electrically connected to the columns and operating in electrical independence of the first beamformer,

a transmit/receive switch electrically connected, respectively, between the first and second beamformers and the rows and columns,

wherein a transmit setting of the switch allows the first and second beamformers to apply signals to the rows and columns of transducer elements, respectively, to form the transmit beams, the signals being time- or phase-delayed, and,

wherein a receive setting of the switch allows the first and second beamformers to receive signals from the row and column transducer elements, respectively, the signals from the rows and columns being, respectively, time- or phase-delayed and combined to form the receive beams.

13. The transducer of Claim 12, wherein the acoustic beams formed by the system are in the Janus configuration.

14. The transducer of Claim 12, wherein the transducer elements are arranged to substantially form a pattern selected from the group consisting of circular, elliptical or polygonal shapes.

15. The transducer of Claim 12, wherein the rows and columns are orthogonal to one another.

16. The transducer of Claim 12, wherein each transducer element has a facial cross-section selected from the group consisting of a circular, elliptical or polygonal shapes.

17. The transducer of Claim 12, wherein the transducer elements are arranged within the array such that the centerline-to-centerline distance between individual elements is one-half of the wavelength of the system acoustic carrier frequency as measured in water and at the front face of the array.

18. The transducer of Claim 12, wherein the transmit/receive beamformer includes multiple bit shift registers.

19. The transducer of Claim 12, wherein each transducer element is symmetric in the facial plane.

20. The transducer of Claim 12, wherein the first and second transmit/receive beamformers provide a virtual ground load impedance to all rows and columns, respectively when the transmit/receive switch is positioned to receive signals.

21. The transducer of Claim 12, wherein the first and second transmit/receive beamformers provide a low source impedance to all rows and columns, respectively when the transmit/receive switch is positioned to transmit signals.

22. The transducer of Claim 12, wherein the rows and columns of transducer elements are electrically connected into P sets of elements by interconnecting each Pth row and column, the first and second transmit/receive beamformers being electrically connected to these P sets of rows and columns, respectively.

23. A method of forming multiple transmit or receive beams from a single planar array having a plurality of transducer elements arranged in N substantially parallel rows and M substantially parallel columns,

wherein the planar array has a first transmit/receive beamformer electrically connected to the rows, a second transmit/receive beamformer electrically connected to the columns, and a transmit/receive switch electrically connected, respectively, between the first and second beamformers and the rows and columns, the method comprising the steps of:

setting the transmit/receive switch to a transmit setting; and

applying signals from the first and second beamformers to the rows and columns of transducer elements, respectively, to form transmit beams, the signals being time- or phase-delayed, or, alternatively,

setting the transmit/receive switch to a receive setting; and

allowing signals from the rows and columns of transducer elements to be applied to the first and second beamformers, respectively, with a time- or phase-delay, to form receive beams.

24. The method of Claim 23, wherein the acoustic beams formed by the system are in the Janus configuration.

25. The method of Claim 23, wherein the transducer elements are arranged to substantially form a pattern selected from the group consisting of circular, elliptical or polygonal shapes.

26. The method of Claim 23, wherein the rows and columns are orthogonal to one another.

27. The method of Claim 23, wherein each transducer element has a facial crosssection selected from the group consisting of a circular, elliptical or polygonal shapes.

28. The method of Claim 23, wherein the transducer elements are arranged within the array such that the centerline-to-centerline distance between individual elements is one-half of the wavelength of the system acoustic carrier frequency as measured in water and at the front face of the array.

29. The method of Claim 23, wherein the transmit/receive beamformer includes multiple bit shift registers.

30. The method of Claim 23, wherein each transducer element is symmetric in the facial plane.

31. The method of Claim 23, wherein the first and second transmit/receive beamformers provide a virtual ground load impedance to all rows and columns, respectively when the transmit/receive switch is positioned to receive signals.

32. The method of Claim 23, wherein the first and second transmit/receive beamformers provide a low source impedance to all rows and columns, respectively when the transmit/receive switch is positioned to transmit signals.

33. The method of Claim 23, wherein the rows and columns of transducer elements are electrically connected into P sets of elements by interconnecting each Pth row and column, the first and second transmit/receive beamformers being electrically connected to these P sets of rows and columns, respectively.

34. The method of Claim 23, wherein the rows and columns of the planar array simultaneously form either transmit or receive beams in two planes.

35. A method of fabricating an acoustic transducer having a plurality of elements comprising the steps of:

providing a transducer blank having first and second substantially parallel faces;

slicing said transducer blank partway through its thickness in one or more dimensions of said first face;

bonding said first face of said transducer blank to a substantially rigid member, said member providing for the electrical connection of one or more of said elements; and

slicing said transducer blank in one or more dimensions of said second face, said slicing of said second face spatially coinciding with the slicing of said first face such that said blank is sliced completely through its thickness, thereby forming individual transducer elements from said blank, each of said elements being bonded to said substantially rigid member.

36. The method of Claim 35, wherein the transducer blank consists of lead-zircon-titanate.

37. The method of Claim 35, wherein the faces of the transducer blank have a crosssection selected from the group consisting of circular, elliptical, square, polygonal, or rectangular shapes.

38. An electro-acoustic transducer capable of simultaneously forming multiple transmit or receive acoustic beams in first and second orthogonal planes and from a single planar aperture, comprising:

a plurality of transducer elements arranged in a planar array of N substantially parallel rows and M substantially parallel columns, each row of transducer elements being electrically connected along a first face of the array, and each column of transducer elements being electrically connected along a second face;

a first transmit/receive beamformer electrically connected to the rows;

a second transmit/receive beamformer electrically connected to the columns and operating in electrical independence of the first beamformer,

a transmit/receive switch electrically connected, respectively, between the first and second beamformers and the rows and columns,

wherein a transmit setting of the switch allows the first and second beamformers to apply signals to the rows and columns of transducer elements, respectively, to form multiple transmit beams within the first and second orthogonal planes, respectively, the beams being at the same angle of inclination relative to a direction normal to the to first and second faces of the planar array, the signals being time- or phase-delayed, and,

wherein a receive setting of the switch allows the first and second beamformers to receive signals from the row and column transducer elements, respectively, the signals from the rows and columns being, respectively, time- or phase-delayed and combined to form receive beams oriented within the first and second orthogonal planes,

the beams being at the same angle of inclination relative to a direction normal to the first and second faces of the planar array.

39. An electro-acoustic system capable of simultaneously transmitting or receiving multiple acoustic beams in a fluid media, comprising:

5 a plurality of transducer elements arranged to form a single two-dimensional array wherein the elements are electrically connected on a first array face in N rows in a first direction, and on a second array face in M columns in a second direction, the connection on the first and second faces being electrically independent;

10 a first transmit/receive beamformer electrically interfaced to the N rows, wherein signals applied to or received from the rows are electrically independent of signals simultaneously applied to or received from the columns;

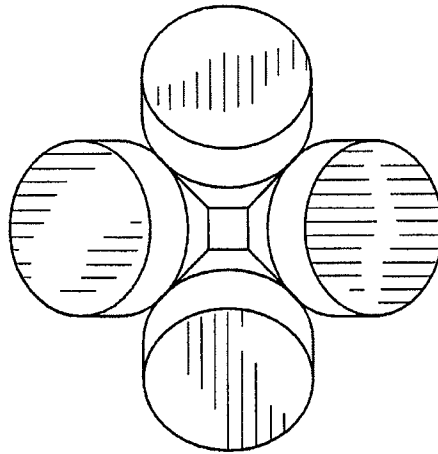
15 a means for operating the first transmit/receive beamformer in a transmit mode, wherein the first beamformer generates a set of N electrical signals, each signal being time- or phase-delayed, and applies each electrical signal to its respective transducer row element, thereby forming a set of multiple transmit acoustic beams inclined outward from a direction normal to the first and second faces, and positioned within a plane oriented normal to the first direction;

20 a means for operating the first transmit/receive beamformer in a receive mode wherein the first beamformer receives a set of electrical signals corresponding to each of the N rows and applies a time or phase delay to each signal, the resulting time-or phase-delayed signals from each row being combined together to form a set of multiple receive acoustic beams inclined outward from a direction normal to the first and second faces, and positioned within a plane oriented normal to the first direction;

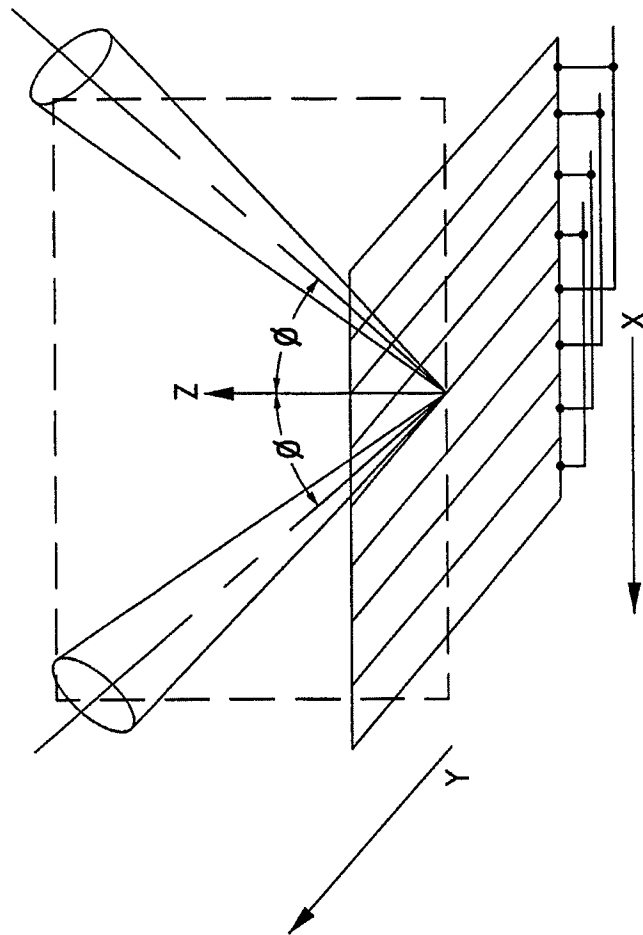
25 a means for operating the second transmit/receive beamformer in a transmit mode, wherein the second beamformer generates a set of M electrical signals, each signal being time- or phase-delayed, and applies each electrical signal to its respective transducer column element, thereby forming a set of multiple transmit acoustic beams inclined outward from a direction normal to the first and second faces, and positioned within a plane oriented normal to the second direction; and

30 a means for operating the second transmit/receive beamformer in a receive mode wherein the second beamformer receives a set of electrical signals corresponding to each of the M columns and applies a time or phase delay to each signal, the resulting time-or phase-delayed signals being combined together to form a set of multiple receive acoustic beams inclined outward from a direction normal to the first and second faces, and positioned within a plane oriented normal to the second direction.

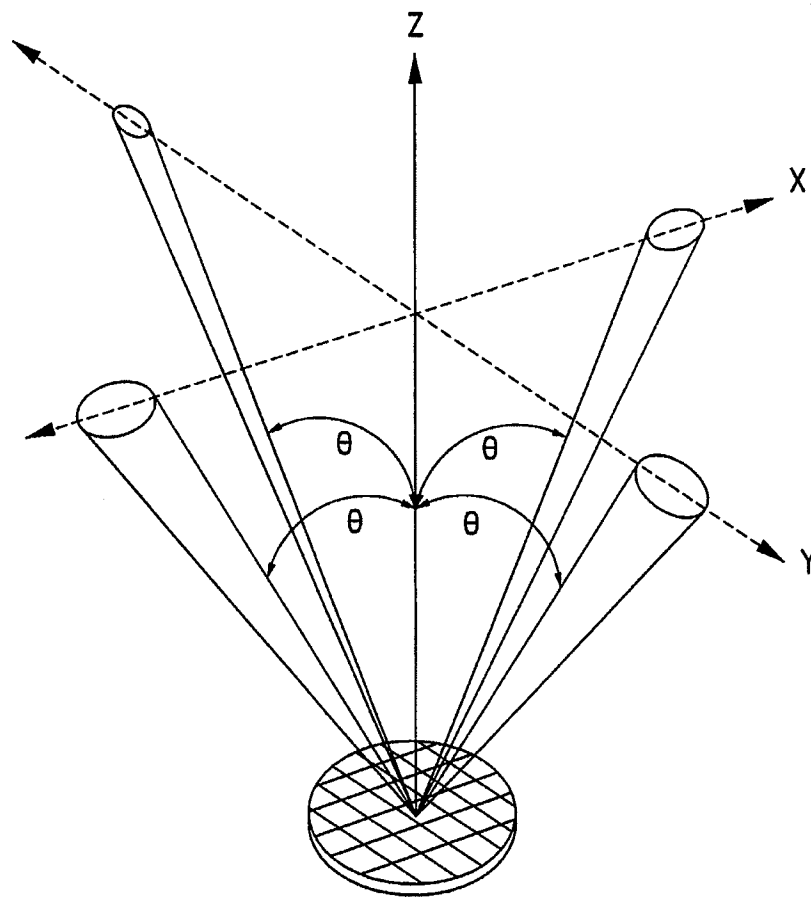
35



*FIG. 1*  
*(PRIOR ART)*



*FIG. 2*  
*(PRIOR ART)*



*FIG. 3*



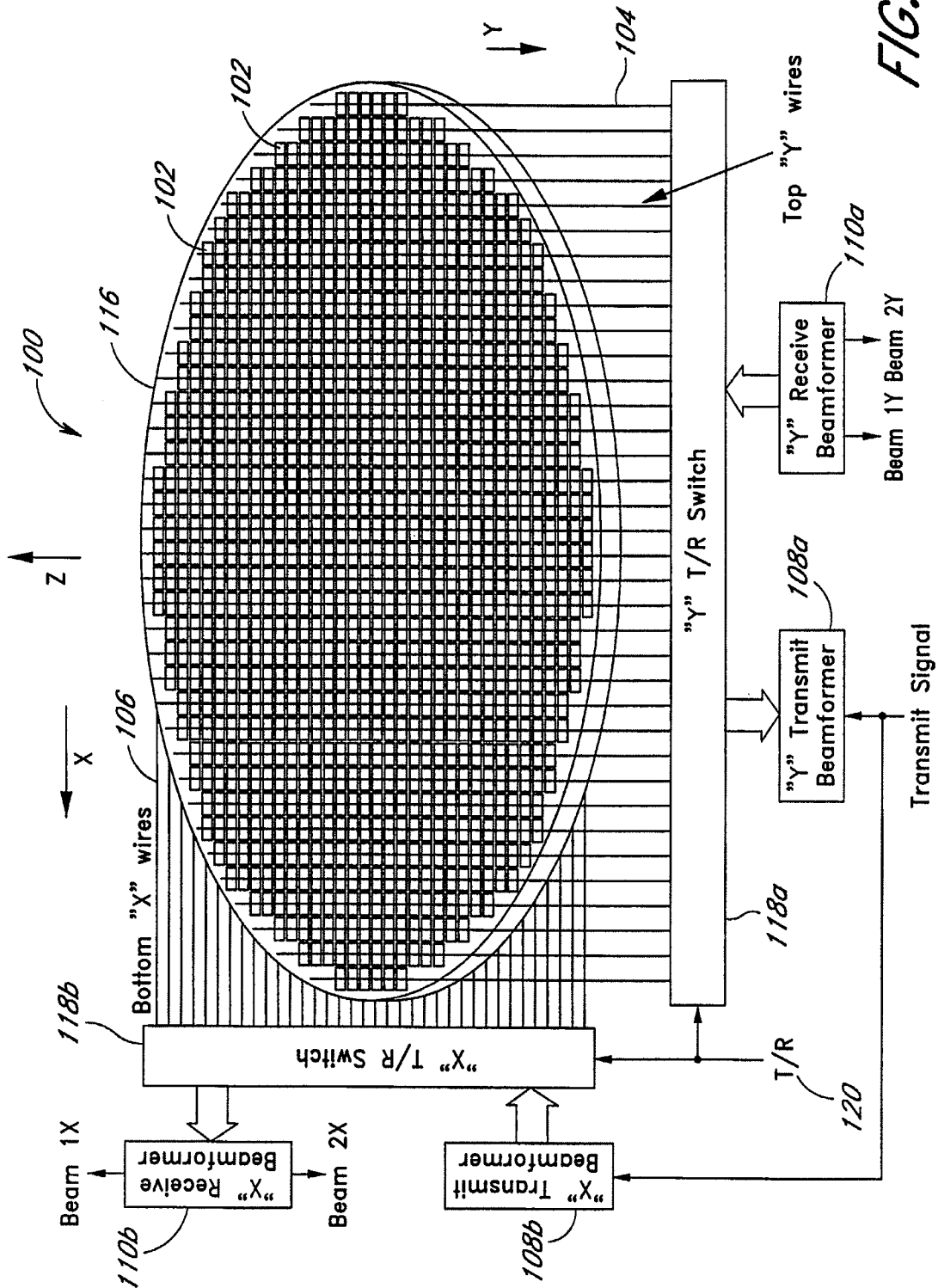


FIG. 4

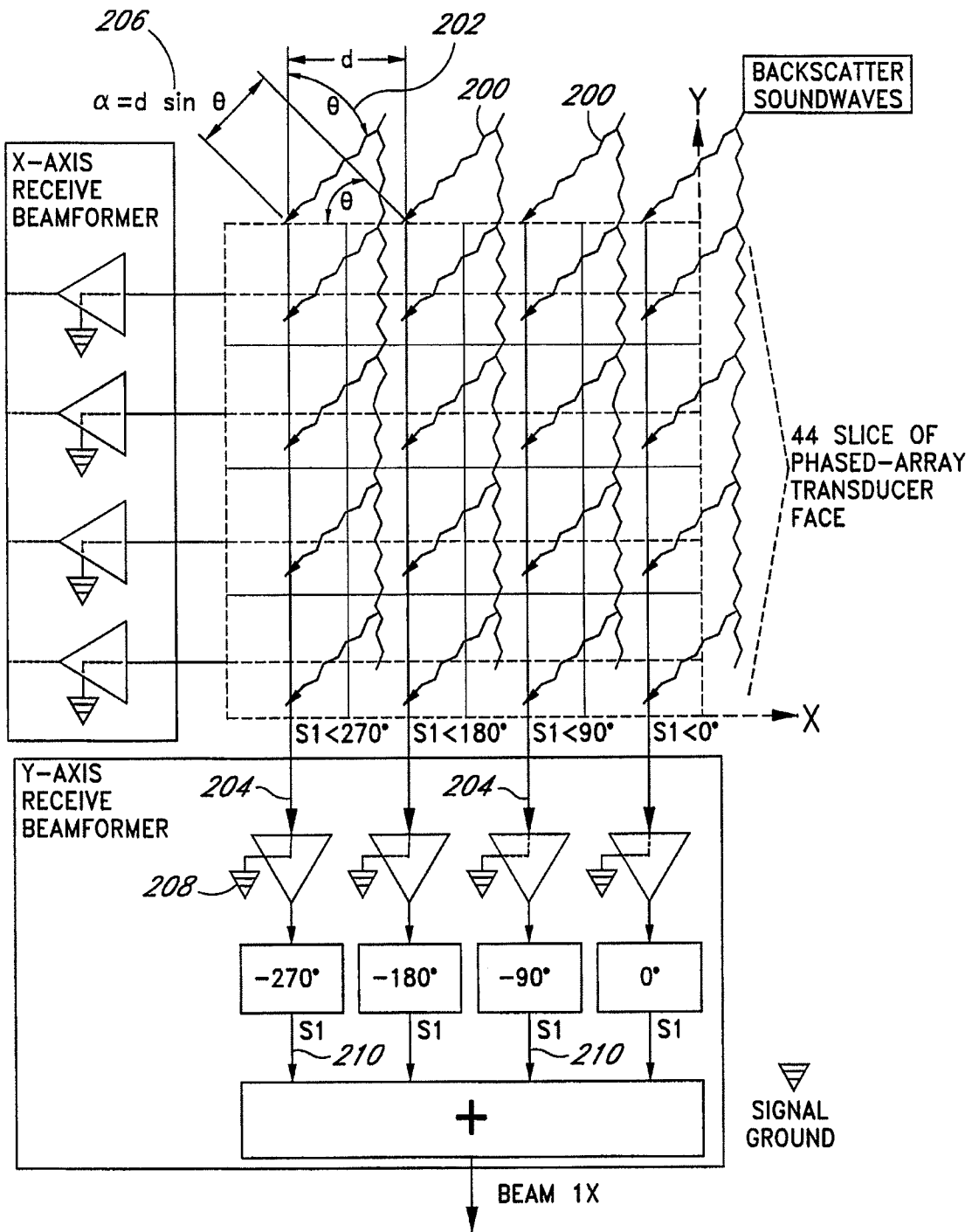


FIG. 5

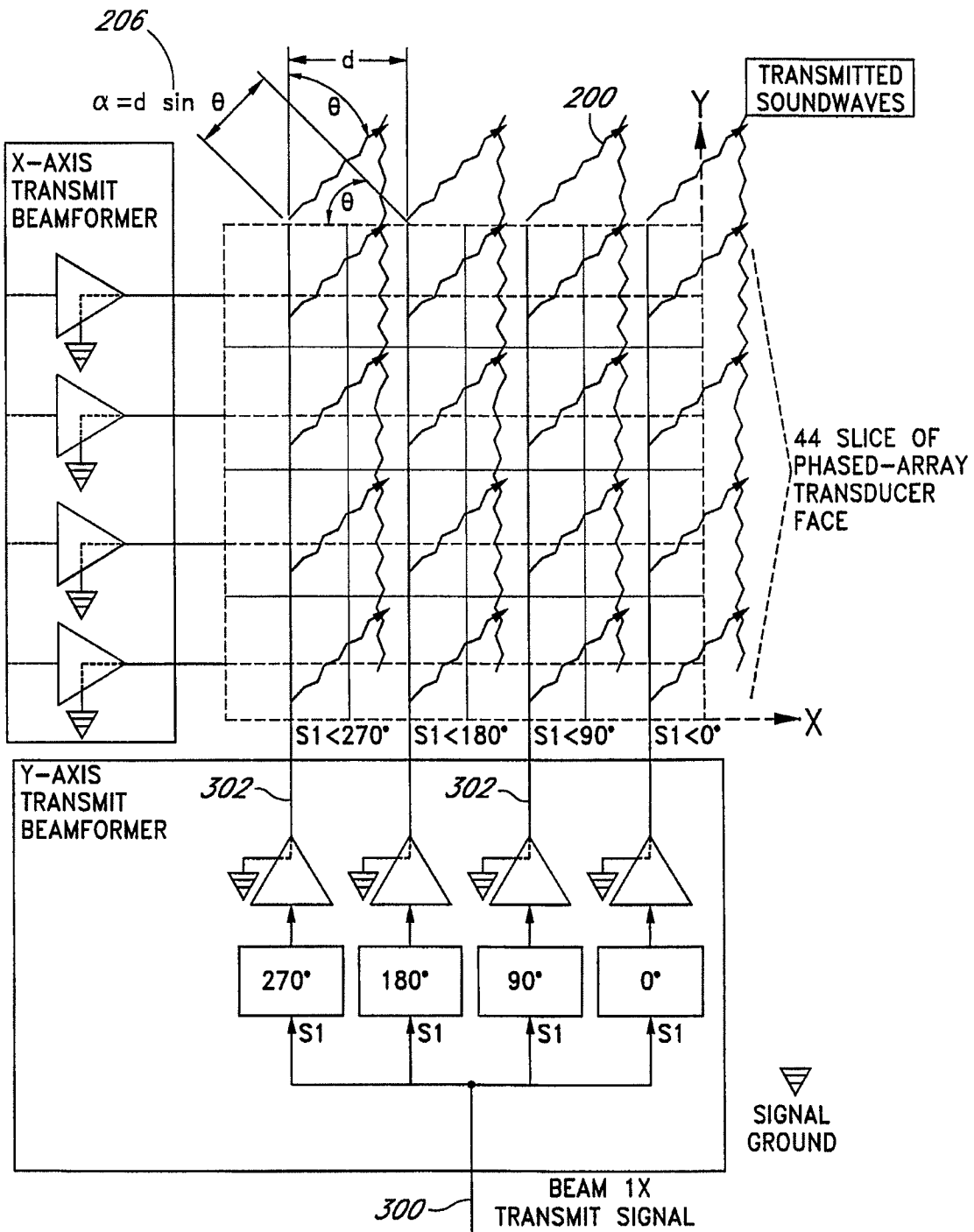


FIG. 6



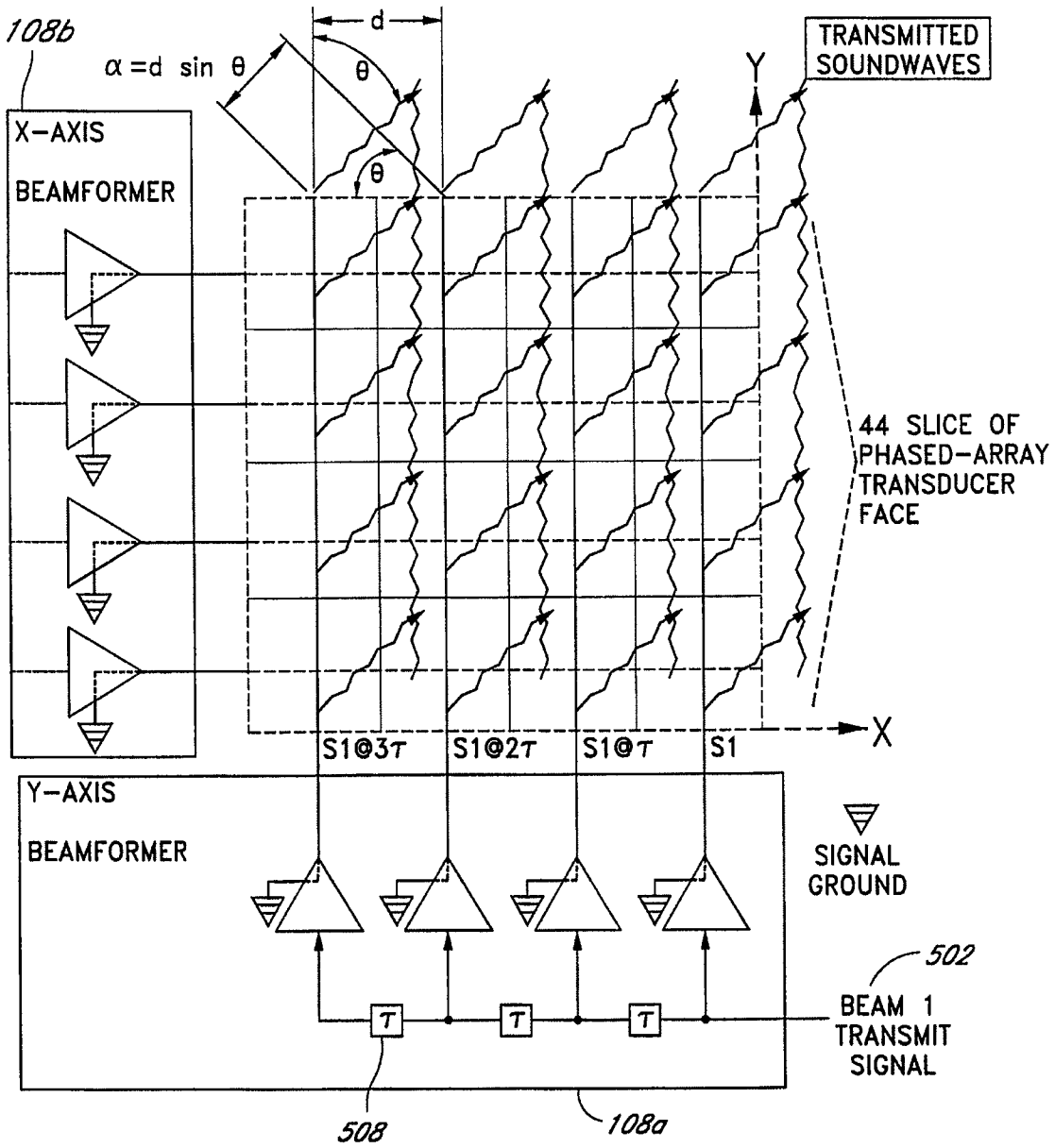


FIG. 8

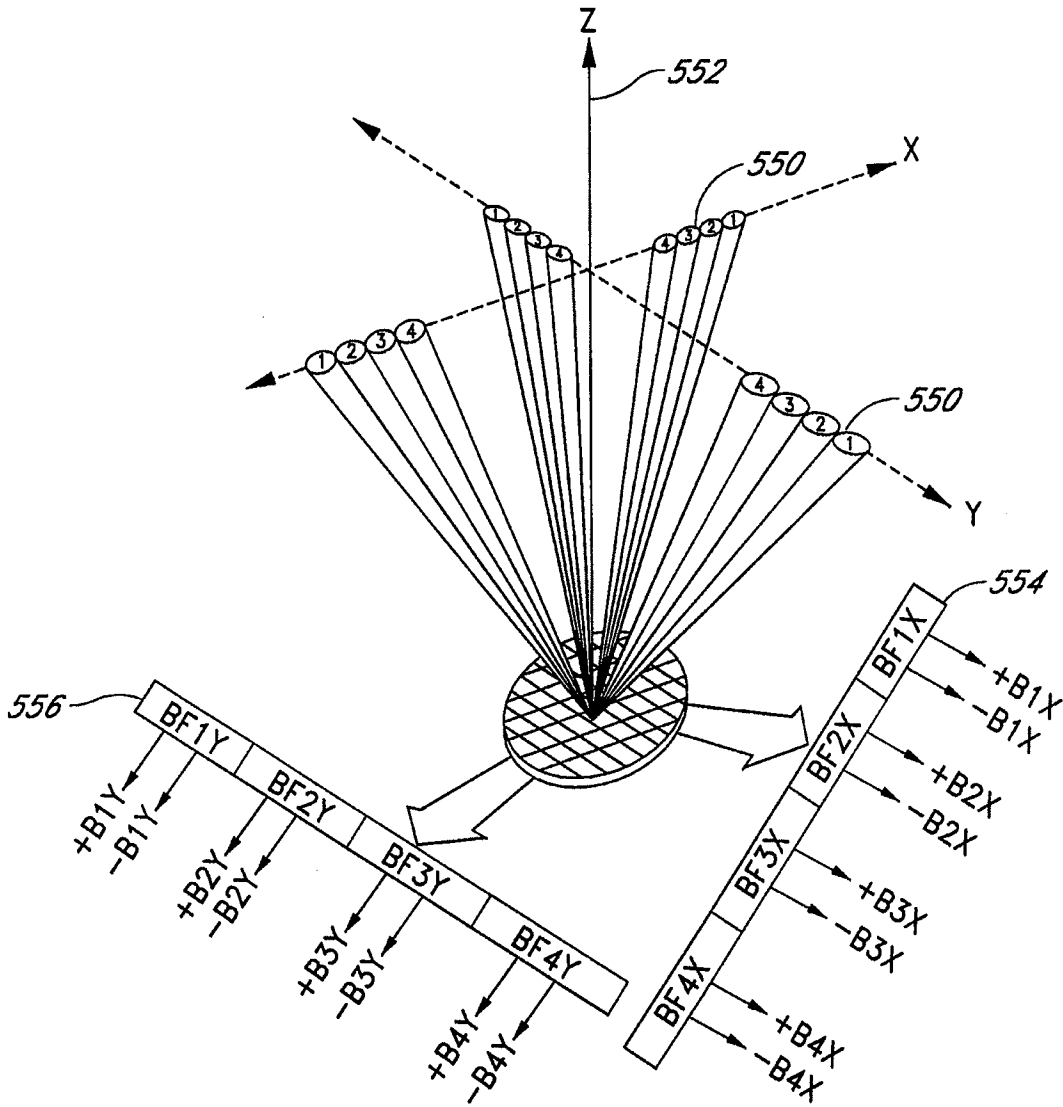
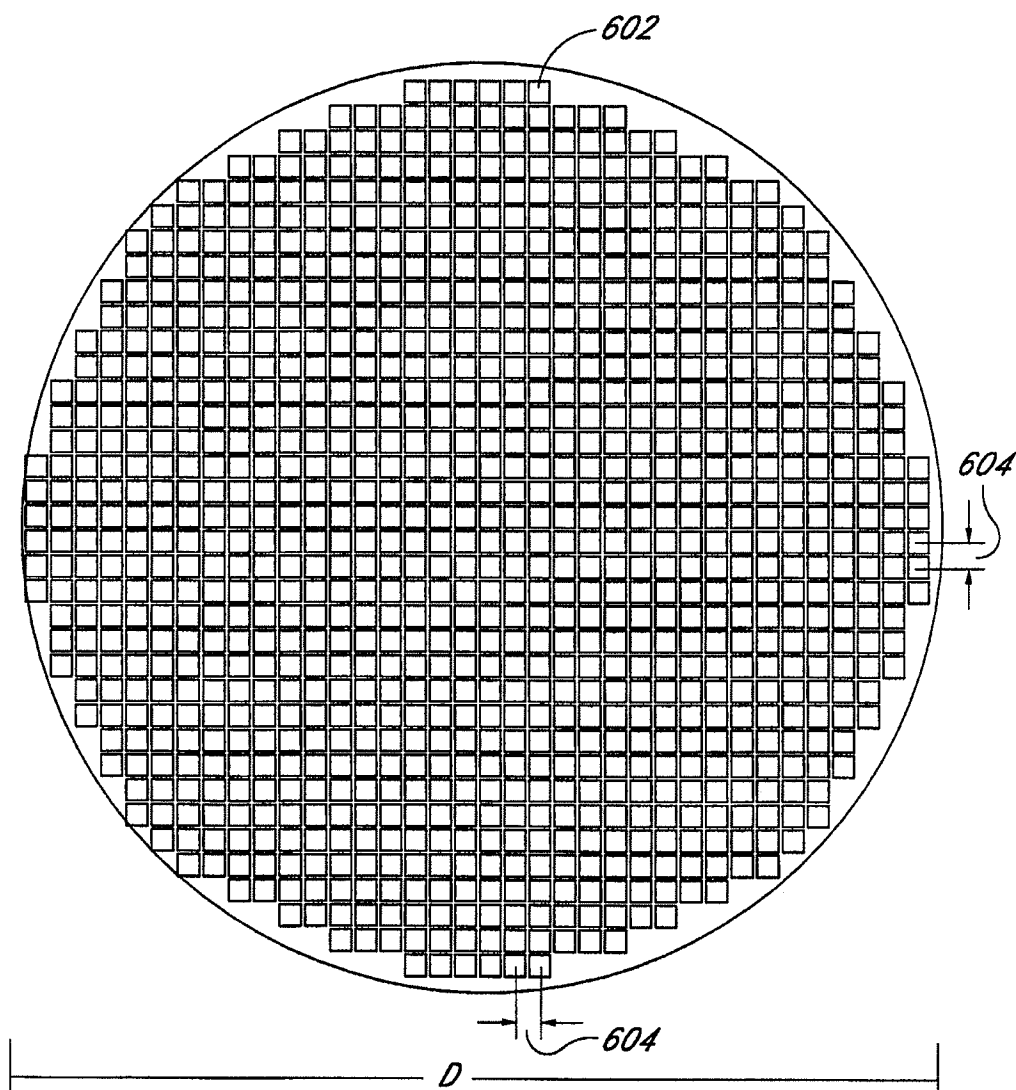
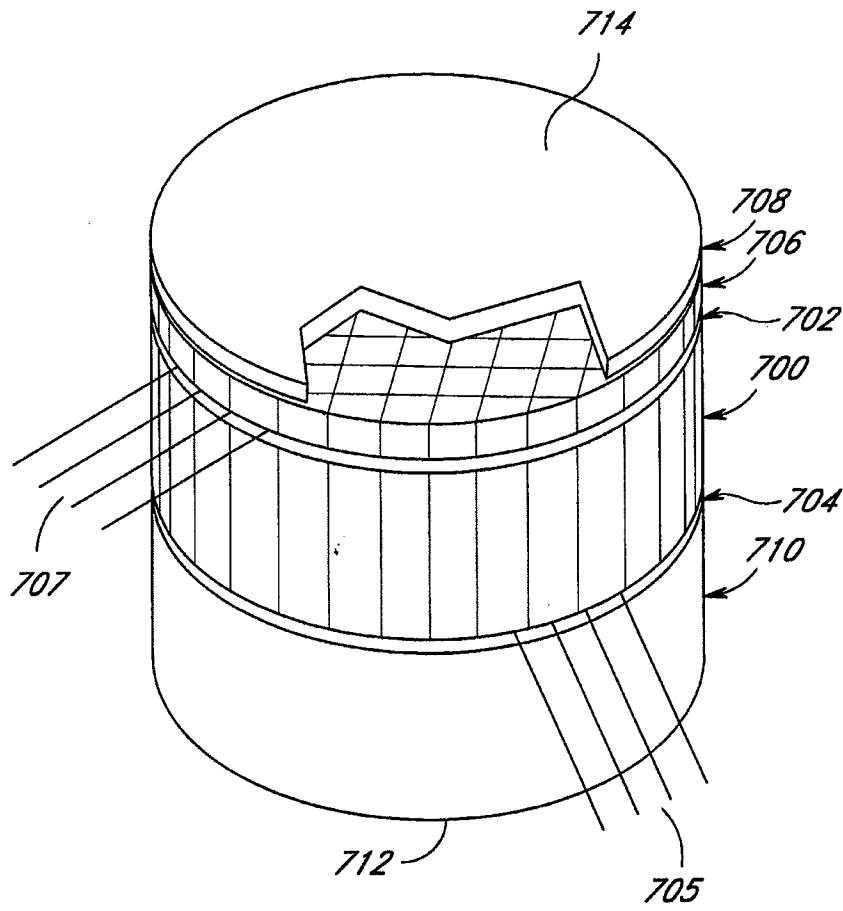


FIG. 9



*FIG. 10*



**FIG. 11**



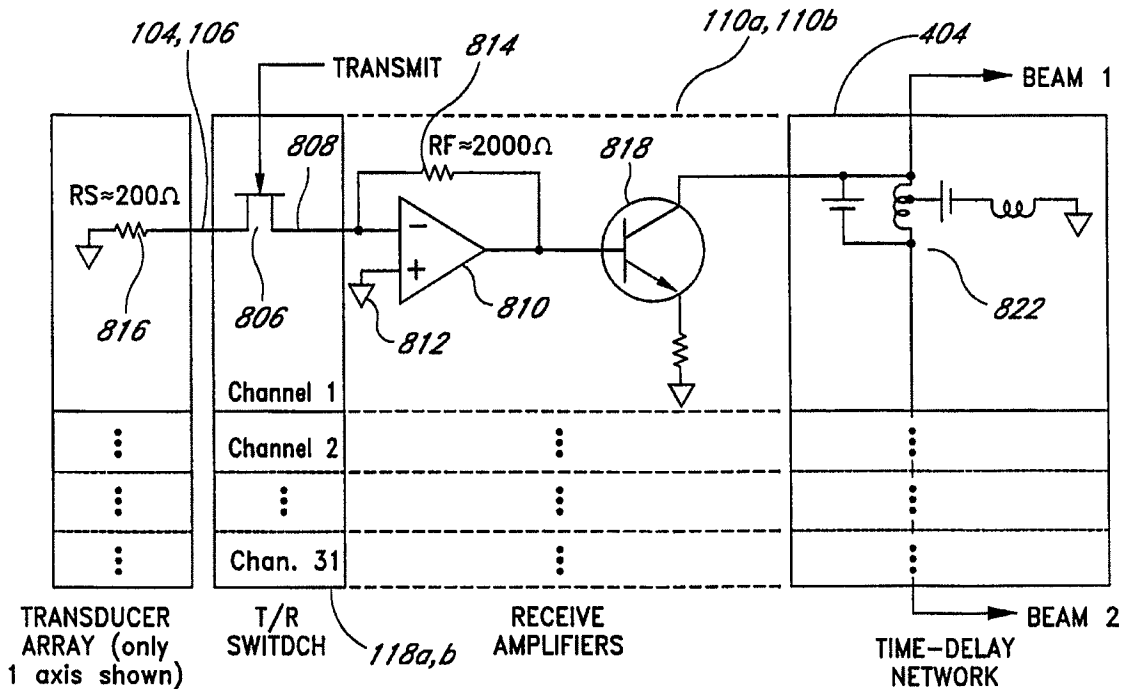


FIG. 12

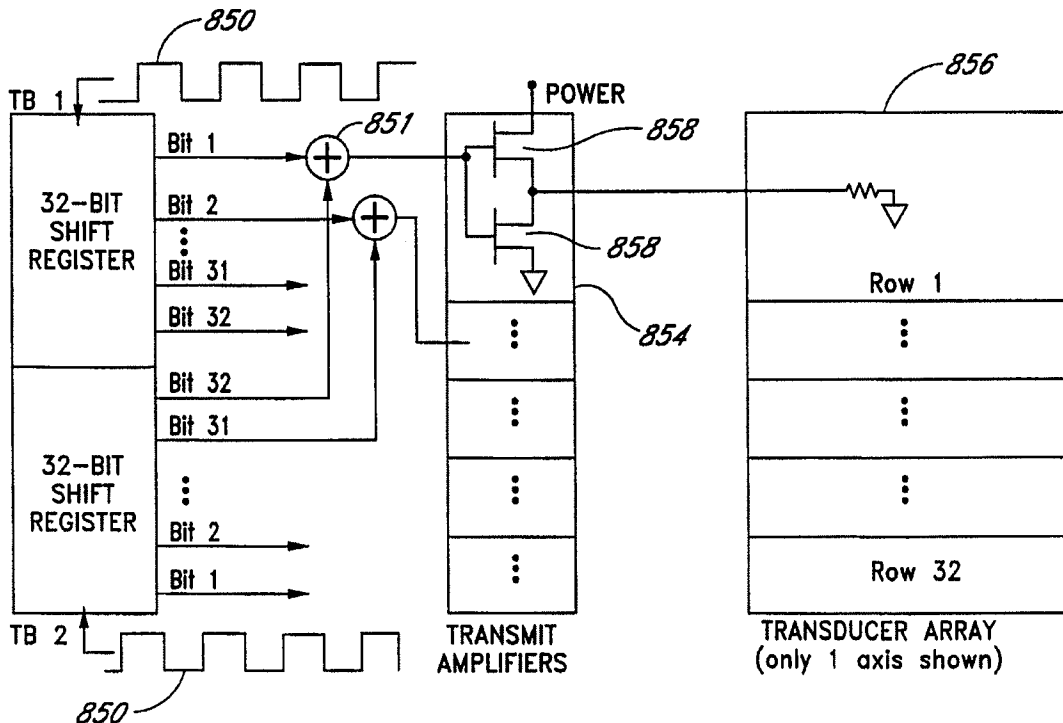


FIG. 13

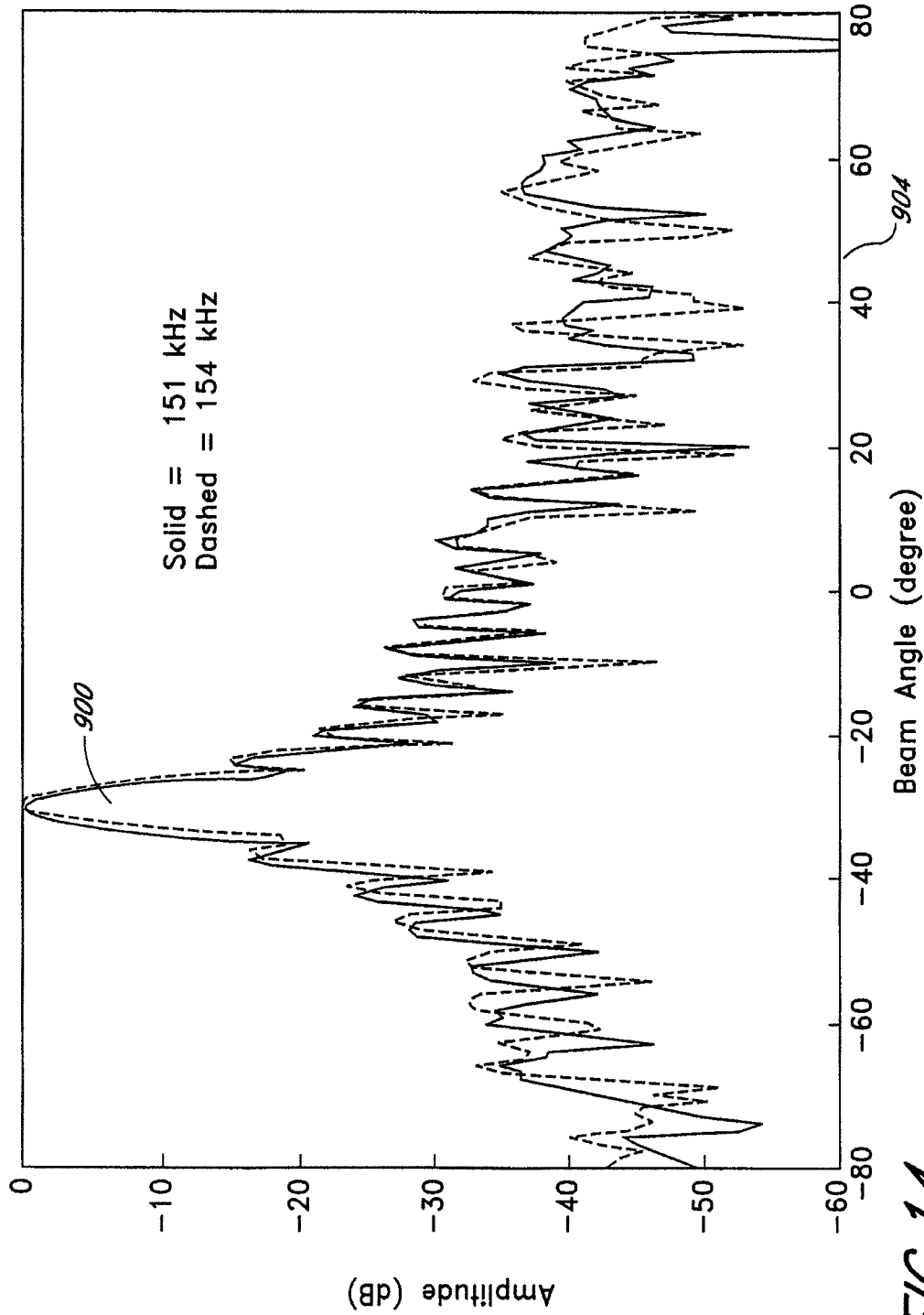


FIG. 14

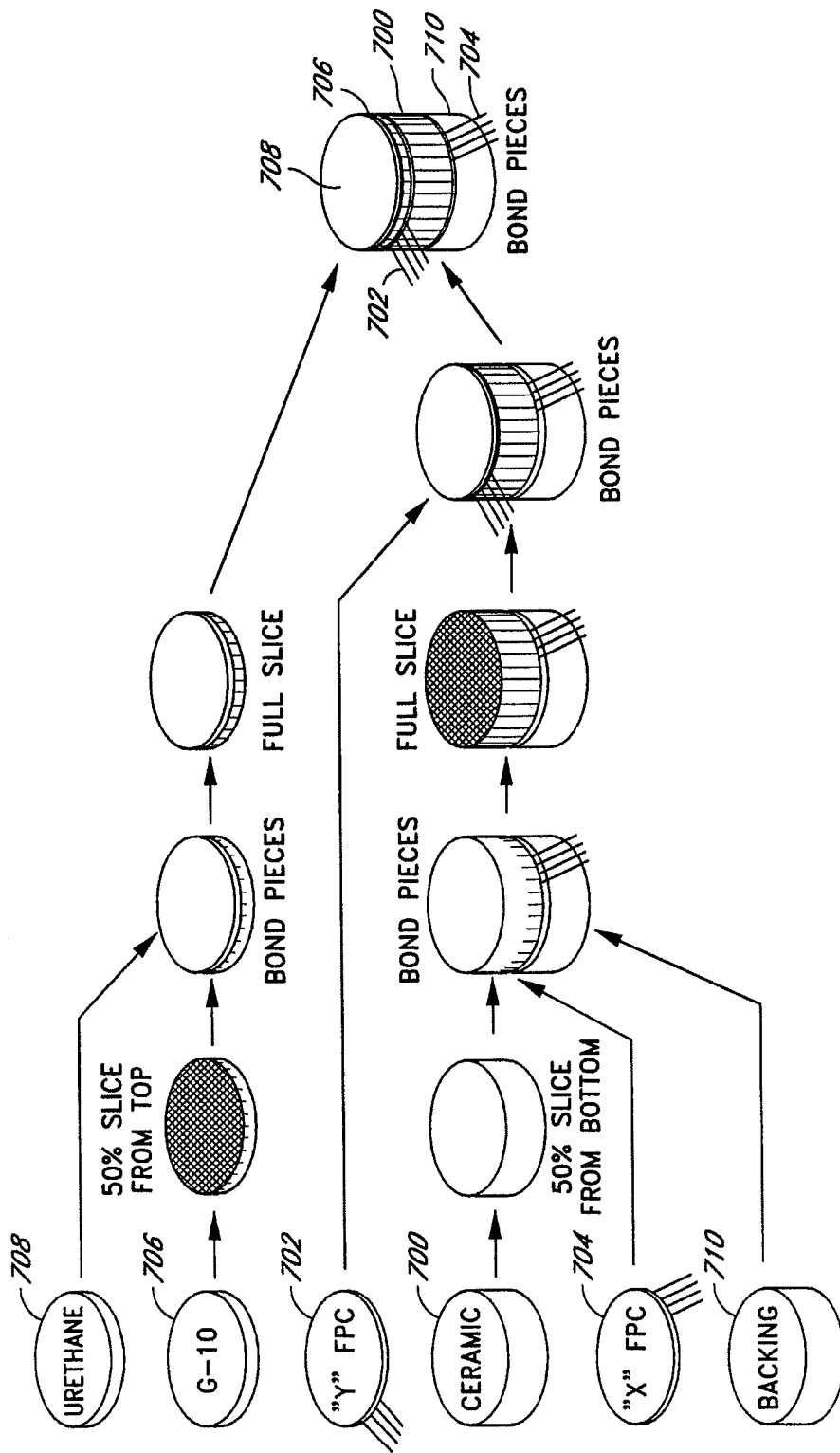


FIG. 15

# INTERNATIONAL SEARCH REPORT

Intern. Application No  
PCT/US 97/18061

<b>A. CLASSIFICATION OF SUBJECT MATTER</b> IPC 6 G01S15/60 G01S15/89				
According to International Patent Classification (IPC) or to both national classification and IPC				
<b>B. FIELDS SEARCHED</b> Minimum documentation searched (classification system followed by classification symbols) IPC 6 G01S G10K H04R B06B				
Documentation searched other than minimum documentation to the extent that such documents are included in the fields searched				
Electronic data base consulted during the international search (name of data base and, where practical, search terms used)				
<b>C. DOCUMENTS CONSIDERED TO BE RELEVANT</b>				
Category °	Citation of document, with indication, where appropriate, of the relevant passages	Relevant to claim No.		
Y	US 5 550 792 A (CRANDALL F ANTHONY ET AL) 27 August 1996  see column 2, line 58 - column 3, line 24; figures 4,5,9  ---	1-4,12, 23,35, 38,39		
Y	SHAULOV A ET AL: "BIPLANE PHASED ARRAY FOR ULTRASONIC MEDICAL IMAGING" PROCEEDINGS OF THE ULTRASONICS SYMPOSIUM, CHICAGO, OCT. 2 - 5, 1988, vol. 1, 2 October 1988, MCAVOY B R, pages 635-638, XP000077019 see page 635, right-hand column; figure 1  ---	1-4		
Y	US 4 641 291 A (SIMMONS SR ROBERT L ET AL) 3 February 1987 cited in the application see column 3 - column 4; figure 10  ---	1-4,12, 23,35, 38,39		
-/--				
<input checked="" type="checkbox"/> Further documents are listed in the continuation of box C.				
<input checked="" type="checkbox"/> Patent family members are listed in annex.				
° Special categories of cited documents :				
<table style="width: 100%; border: none;"> <tr> <td style="width: 50%; border: none; vertical-align: top;">                     *A* document defining the general state of the art which is not considered to be of particular relevance                      *E* earlier document but published on or after the international filing date                      *L* document which may throw doubts on priority claim(s) or which is cited to establish the publication date of another citation or other special reason (as specified)                      *O* document referring to an oral disclosure, use, exhibition or other means                      *P* document published prior to the international filing date but later than the priority date claimed                 </td> <td style="width: 50%; border: none; vertical-align: top;">                     *T* later document published after the international filing date or priority date and not in conflict with the application but cited to understand the principle or theory underlying the invention                      *X* document of particular relevance; the claimed invention cannot be considered novel or cannot be considered to involve an inventive step when the document is taken alone                      *Y* document of particular relevance; the claimed invention cannot be considered to involve an inventive step when the document is combined with one or more other such documents, such combination being obvious to a person skilled in the art.                      *&amp;* document member of the same patent family                 </td> </tr> </table>			*A* document defining the general state of the art which is not considered to be of particular relevance *E* earlier document but published on or after the international filing date *L* document which may throw doubts on priority claim(s) or which is cited to establish the publication date of another citation or other special reason (as specified) *O* document referring to an oral disclosure, use, exhibition or other means *P* document published prior to the international filing date but later than the priority date claimed	*T* later document published after the international filing date or priority date and not in conflict with the application but cited to understand the principle or theory underlying the invention *X* document of particular relevance; the claimed invention cannot be considered novel or cannot be considered to involve an inventive step when the document is taken alone *Y* document of particular relevance; the claimed invention cannot be considered to involve an inventive step when the document is combined with one or more other such documents, such combination being obvious to a person skilled in the art. *&* document member of the same patent family
*A* document defining the general state of the art which is not considered to be of particular relevance *E* earlier document but published on or after the international filing date *L* document which may throw doubts on priority claim(s) or which is cited to establish the publication date of another citation or other special reason (as specified) *O* document referring to an oral disclosure, use, exhibition or other means *P* document published prior to the international filing date but later than the priority date claimed	*T* later document published after the international filing date or priority date and not in conflict with the application but cited to understand the principle or theory underlying the invention *X* document of particular relevance; the claimed invention cannot be considered novel or cannot be considered to involve an inventive step when the document is taken alone *Y* document of particular relevance; the claimed invention cannot be considered to involve an inventive step when the document is combined with one or more other such documents, such combination being obvious to a person skilled in the art. *&* document member of the same patent family			
Date of the actual completion of the international search  19 January 1998	Date of mailing of the international search report  28.01.98			
Name and mailing address of the ISA European Patent Office, P.B. 5818 Patentlaan 2 NL - 2280 HV Rijswijk Tel. (+31-70) 340-2040, Tx. 31 651 epo nl, Fax: (+31-70) 340-3016	Authorized officer  Breusing, J			

2

# INTERNATIONAL SEARCH REPORT

Int. ..onal Application No  
PCT/US 97/18061

C.(Continuation) DOCUMENTS CONSIDERED TO BE RELEVANT		
Category °	Citation of document, with indication, where appropriate, of the relevant passages	Relevant to claim No.
A	WO 92 05456 A (ROWE DEINES INSTR INC) 2 April 1992 see page 2, line 14 - page 11, line 1 & US 5 483 499 A cited in the application ---	2,13,24, 39
A	US 5 530 683 A (LINDBERG JAN F) 25 June 1996 see abstract; figures 3,4 ---	1
A	EP 0 524 749 A (TOKYO SHIBAURA ELECTRIC CO) 27 January 1993 see column 4, line 54 - column 5, line 10; figures 1,4 see column 7, line 20 - column 8, line 15 ---	1,12,23, 35
A	WO 95 06885 A (THOMSON CSF ;PERENNES MARC (FR)) 9 March 1995 see page 1, line 19 - page 2, line 15; figures 1-6 ---	1
A	GB 2 053 475 A (PHILIPS NV) 4 February 1981 see abstract; figure 1 ---	4,15,26
A	EP 0 383 270 A (HITACHI LTD) 22 August 1990 see column 2, line 28 - column 3, line 9; figure 1 ---	1
A	EP 0 616 231 A (INST BIOMEDIZINISCHE TECHNIK) 21 September 1994 see abstract; figure 2 -----	

# INTERNATIONAL SEARCH REPORT

Information on patent family members

International Application No

PCT/US 97/18061

Patent document cited in search report	Publication date	Patent family member(s)	Publication date
US 5550792 A	27-08-96	NONE	
US 4641291 A	03-02-87	NONE	
WO 9205456 A	02-04-92	AU 652699 B	01-09-94
		AU 8758191 A	15-04-92
		CA 2092564 A	27-03-92
		DE 69126040 D	12-06-97
		DE 69126040 T	02-01-98
		EP 0573431 A	15-12-93
		JP 6503163 T	07-04-94
		US 5483499 A	09-01-96
		US RE35535 E	17-06-97
		US 5615173 A	25-03-97
		US 5208785 A	04-05-93
US 5530683 A	25-06-96	NONE	
EP 0524749 A	27-01-93	DE 69213600 D	17-10-96
		DE 69213600 T	27-02-97
		JP 5228142 A	07-09-93
		US 5327895 A	12-07-94
WO 9506885 A	09-03-95	FR 2709559 A	10-03-95
		CA 2169935 A	09-03-95
		DE 69402084 D	17-04-97
		DE 69402084 T	19-06-97
		EP 0716751 A	19-06-96
		US 5694372 A	02-12-97
GB 2053475 A	04-02-81	FR 2460489 A	23-01-81
		AU 537043 B	31-05-84
		AU 5976580 A	15-01-81
		BE 884155 A	05-01-81
		CA 1146662 A	17-05-83
		DE 3025168 A	08-01-81
		JP 1342741 C	14-10-86
		JP 56011374 A	04-02-81
		JP 61006348 B	25-02-86
		NL 8003770 A	06-01-81


PATENT COOPERATION TREATY

Alston & Bird

MF

OCT 12 2010

From the INTERNATIONAL SEARCHING AUTHORITY

PCT Received By 

To:  
 Thorson, Chad L.  
 ALSTON & BIRD LLP  
 Bank of America Plaza  
 101 South Tryon Street, Suite 4000  
 Charlotte, NC 28280-4000  
 ETATS-UNIS D'AMERIQUE

NOTIFICATION OF TRANSMITTAL OF THE INTERNATIONAL SEARCH REPORT AND THE WRITTEN OPINION OF THE INTERNATIONAL SEARCHING AUTHORITY, OR THE DECLARATION

(PCT Rule 44.1)

Applicant's or agent's file reference 38495/388217	Date of mailing (day/month/year) 6 October 2010 (06-10-2010)
International application No. PCT/US2010/039443	<b>FOR FURTHER ACTION</b> See paragraphs 1 and 4 below International filing date (day/month/year) 22 June 2010 (22-06-2010)
Applicant NAVICO, INC.	

1.  The applicant is hereby notified that the international search report and the written opinion of the International Searching Authority have been established and are transmitted herewith.

**Filing of amendments and statement under Article 19:**

The applicant is entitled, if he so wishes, to amend the claims of the International Application (see Rule 46):

**When?** The time limit for filing such amendments is normally two months from the date of transmittal of the International Search Report.

**Where?** Directly to the International Bureau of WIPO, 34 chemin des Colombettes  
1211 Geneva 20, Switzerland, Facsimile No.: (41-22) 338.82.70

For more detailed instructions, see the notes on the accompanying sheet.

2.  The applicant is hereby notified that no international search report will be established and that the declaration under Article 17(2)(a) to that effect and the written opinion of the International Searching Authority are transmitted herewith.

3.  With regard to any protest against payment of (an) additional fee(s) under Rule 40.2, the applicant is notified that:

- the protest together with the decision thereon has been transmitted to the International Bureau together with the applicant's request to forward the texts of both the protest and the decision thereon to the designated Offices.
- no decision has been made yet on the protest; the applicant will be notified as soon as a decision is made.

4. Reminders


Shortly after the expiration of 18 months from the priority date, the international application will be published by the International Bureau. If the applicant wishes to avoid or postpone publication, a notice of withdrawal of the international application, or of the priority claim, must reach the International Bureau as provided in Rules 90bis.1 and 90bis.3, respectively, before the completion of the technical preparations for international publication.

The applicant may submit comments on an informal basis on the written opinion of the International Searching Authority to the International Bureau. The International Bureau will send a copy of such comments to all designated Offices unless an international preliminary examination report has been or is to be established. These comments would also be made available to the public but not before the expiration of 30 months from the priority date.

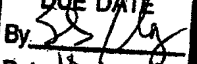
Within 19 months from the priority date, but only in respect of some designated Offices, a demand for international preliminary examination must be filed if the applicant wishes to postpone the entry into the national phase until 30 months from the priority date (in some Offices even later); otherwise, the applicant must, within 20 months from the priority date, perform the prescribed acts for entry into the national phase before those designated Offices.

In respect of other designated Offices, the time limit of 30 months (or later) will apply even if no demand is filed within 19 months.

See the Annex to Form PCT/IB/301 and, for details about the applicable time limits, Office by Office, see the PCT Applicant's Guide, National Chapters.

Name and mailing address of the International Searching Authority  
 European Patent Office, P.B. 5818 Patentlaan 2  
 NL-2280 HV Rijswijk  
 Tel. (+31-70) 340-2040  
 Fax: (+31-70) 340-3016

Authorized officer  
 WALSH, Eric  
 Tel: +31 (0)70 340-3813

DOCKETED  
 DUE DATE  
 By   
 Date 10-12-10

**PATENT COOPERATION TREATY**

**PCT**

**INTERNATIONAL SEARCH REPORT**

(PCT Article 18 and Rules 43 and 44)

Applicant's or agent's file reference 38495/388217	<b>FOR FURTHER ACTION</b>		see Form PCT/ISA/220 as well as, where applicable, item 5 below.
International application No. PCT/US2010/039443	International filing date (day/month/year) 22/06/2010	(Earliest) Priority Date (day/month/year) 14/07/2009	
Applicant  NAVICO, INC.			

This international search report has been prepared by this International Searching Authority and is transmitted to the applicant according to Article 18. A copy is being transmitted to the International Bureau.

This international search report consists of a total of 4 sheets.

It is also accompanied by a copy of each prior art document cited in this report.

**1. Basis of the report**

a. With regard to the **language**, the international search was carried out on the basis of:

- the international application in the language in which it was filed  
 a translation of the international application into \_\_\_\_\_, which is the language of a translation furnished for the purposes of international search (Rules 12.3(a) and 23.1(b))

b.  This international search report has been established taking into account the **rectification of an obvious mistake** authorized by or notified to this Authority under Rule 91 (Rule 43.6bis(a)).

c.  With regard to any **nucleotide and/or amino acid sequence** disclosed in the international application, see Box No. I.

2.  **Certain claims were found unsearchable** (See Box No. II)

3.  **Unity of invention is lacking** (see Box No III)

4. With regard to the **title**,

- the text is approved as submitted by the applicant  
 the text has been established by this Authority to read as follows:

5. With regard to the **abstract**,

- the text is approved as submitted by the applicant  
 the text has been established, according to Rule 38.2(b), by this Authority as it appears in Box No. IV. The applicant may, within one month from the date of mailing of this international search report, submit comments to this Authority

6. With regard to the **drawings**,

- a. the figure of the **drawings** to be published with the abstract is Figure No. 8a  
 as suggested by the applicant  
 as selected by this Authority, because the applicant failed to suggest a figure  
 as selected by this Authority, because this figure better characterizes the invention
- b.  none of the figures is to be published with the abstract



INTERNATIONAL SEARCH REPORT

International application No  
PCT/US2010/039443

<b>A. CLASSIFICATION OF SUBJECT MATTER</b> INV. G01S15/89 G01S15/96 ADD.		
According to International Patent Classification (IPC) or to both national classification and IPC		
<b>B. FIELDS SEARCHED</b>		
Minimum documentation searched (classification system followed by classification symbols) G01S		
Documentation searched other than minimum documentation to the extent that such documents are included in the fields searched		
Electronic data base consulted during the international search (name of data base and, where practical, search terms used) EPO-Internal		
<b>C. DOCUMENTS CONSIDERED TO BE RELEVANT</b>		
Category*	Citation of document, with indication, where appropriate, of the relevant passages	Relevant to claim No.
Y	WO 98/15846 A1 (ROWE DEINES INSTR INC [US]) 16 April 1998 (1998-04-16) figures 3,4 * abstract page 7, line 32 claim 1	1-99
Y	US 3 618 006 A (WRIGHT CHARLES P) 2 November 1971 (1971-11-02) * abstract; figures 1,2	1-99
A	US 5 184 330 A (ADAMS JAMES W [US] ET AL) 2 February 1993 (1993-02-02) figures 4,5,6 * abstract	1
----- -/--		
<input checked="" type="checkbox"/> Further documents are listed in the continuation of Box C.		
<input checked="" type="checkbox"/> See patent family annex.		
* Special categories of cited documents :		
*A* document defining the general state of the art which is not considered to be of particular relevance *E* earlier document but published on or after the international filing date *L* document which may throw doubts on priority claim(s) or which is cited to establish the publication date of another citation or other special reason (as specified) *O* document referring to an oral disclosure, use, exhibition or other means *P* document published prior to the international filing date but later than the priority date claimed		
*T* later document published after the international filing date or priority date and not in conflict with the application but cited to understand the principle or theory underlying the invention *X* document of particular relevance; the claimed invention cannot be considered novel or cannot be considered to involve an inventive step when the document is taken alone *Y* document of particular relevance; the claimed invention cannot be considered to involve an inventive step when the document is combined with one or more other such documents, such combination being obvious to a person skilled in the art. *&* document member of the same patent family		
Date of the actual completion of the international search  29 September 2010		Date of mailing of the international search report  06/10/2010
Name and mailing address of the ISA/ European Patent Office, P.B. 5818 Patentlaan 2 NL - 2280 HV Rijswijk Tel. (+31-70) 340-2040, Fax: (+31-70) 340-3016		Authorized officer  Alberga, Vito

1

INTERNATIONAL SEARCH REPORT

International application No  
PCT/US2010/039443

C(Continuation). DOCUMENTS CONSIDERED TO BE RELEVANT

Category*	Citation of document, with indication, where appropriate, of the relevant passages	Relevant to claim No.
A	US 4 879 697 A (LOWRANCE DARRELL J [US] ET AL) 7 November 1989 (1989-11-07) figure 4 * abstract	1
A	----- US 5 694 372 A (PERENNES MARC [FR]) 2 December 1997 (1997-12-02) figures 1,2 * abstract -----	1

# INTERNATIONAL SEARCH REPORT

Information on patent family members

International application No PCT/US2010/039443
---

Patent document cited in search report	Publication date	Publication date	Patent family member(s)	Publication date
WO 9815846	A1	16-04-1998	AT 236409 T	15-04-2003
			DE 69720483 D1	08-05-2003
			DE 69720483 T2	24-12-2003
			EP 0929825 A1	21-07-1999
			JP 3995270 B2	24-10-2007
			JP 2001502058 T	13-02-2001
			JP 4087430 B2	21-05-2008
			JP 2007192830 A	02-08-2007
			NO 991555 A	04-06-1999
			US 5808967 A	15-09-1998
US 3618006	A	02-11-1971	NONE	
US 5184330	A	02-02-1993	NONE	
US 4879697	A	07-11-1989	NONE	
US 5694372	A	02-12-1997	DE 69402084 D1	17-04-1997
			DE 69402084 T2	19-06-1997
			EP 0716751 A1	19-06-1996
			FR 2709559 A1	10-03-1995
			WO 9506885 A1	09-03-1995

# PATENT COOPERATION TREATY

From the  
INTERNATIONAL SEARCHING AUTHORITY

To:

see form PCT/ISA/220

## PCT

WRITTEN OPINION OF THE  
INTERNATIONAL SEARCHING AUTHORITY  
(PCT Rule 43bis.1)

Date of mailing  
(day/month/year) see form PCT/ISA/210 (second sheet)

Applicant's or agent's file reference see form PCT/ISA/220	<b>FOR FURTHER ACTION</b> See paragraph 2 below
---	--

International application No. PCT/US2010/039443	International filing date (day/month/year) 22.06.2010	Priority date (day/month/year) 14.07.2009
--	--	--

International Patent Classification (IPC) or both national classification and IPC  
INV. G01S15/89 G01S15/96

Applicant  
NAVICO, INC.

1. This opinion contains indications relating to the following items:

- Box No. I Basis of the opinion
- Box No. II Priority
- Box No. III Non-establishment of opinion with regard to novelty, inventive step and industrial applicability
- Box No. IV Lack of unity of invention
- Box No. V Reasoned statement under Rule 43bis.1(a)(i) with regard to novelty, inventive step and industrial applicability; citations and explanations supporting such statement
- Box No. VI Certain documents cited
- Box No. VII Certain defects in the international application
- Box No. VIII Certain observations on the international application


2. **FURTHER ACTION**

If a demand for international preliminary examination is made, this opinion will usually be considered to be a written opinion of the International Preliminary Examining Authority ("IPEA") except that this does not apply where the applicant chooses an Authority other than this one to be the IPEA and the chosen IPEA has notified the International Bureau under Rule 66.1bis(b) that written opinions of this International Searching Authority will not be so considered.

If this opinion is, as provided above, considered to be a written opinion of the IPEA, the applicant is invited to submit to the IPEA a written reply together, where appropriate, with amendments, before the expiration of 3 months from the date of mailing of Form PCT/ISA/220 or before the expiration of 22 months from the priority date, whichever expires later.

For further options, see Form PCT/ISA/220.

3. For further details, see notes to Form PCT/ISA/220.

Name and mailing address of the ISA:   European Patent Office P.B. 5818 Patentlaan 2 NL-2280 HV Rijswijk - Pays Bas Tel. +31 70 340 - 2040 Fax: +31 70 340 - 3016	Date of completion of this opinion  see form PCT/ISA/210	Authorized Officer  Alberga, Vito  Telephone No. +31 70 340-2798
--	--	--



**WRITTEN OPINION OF THE  
INTERNATIONAL SEARCHING AUTHORITY**

International application No.  
PCT/US2010/039443

---

**Box No. I Basis of the opinion**

---

1. With regard to the **language**, this opinion has been established on the basis of:
- the international application in the language in which it was filed
  - a translation of the international application into , which is the language of a translation furnished for the purposes of international search (Rules 12.3(a) and 23.1 (b)).
2.  This opinion has been established taking into account the **rectification of an obvious mistake** authorized by or notified to this Authority under Rule 91 (Rule 43bis.1(a))
3. With regard to any **nucleotide and/or amino acid sequence** disclosed in the international application, this opinion has been established on the basis of a sequence listing filed or furnished:
- a. (means)
    - on paper
    - in electronic form
  - b. (time)
    - in the international application as filed
    - together with the international application in electronic form
    - subsequently to this Authority for the purposes of search
4.  In addition, in the case that more than one version or copy of a sequence listing has been filed or furnished, the required statements that the information in the subsequent or additional copies is identical to that in the application as filed or does not go beyond the application as filed, as appropriate, were furnished.
5. Additional comments:

---

**Box No. V Reasoned statement under Rule 43bis.1(a)(i) with regard to novelty, inventive step or industrial applicability; citations and explanations supporting such statement**

---

1. Statement

Novelty (N)	Yes: Claims	<u>1-99</u>
	No: Claims	
Inventive step (IS)	Yes: Claims	
	No: Claims	<u>1-99</u>
Industrial applicability (IA)	Yes: Claims	<u>1-99</u>
	No: Claims	

2. Citations and explanations

**see separate sheet**

---

**Box No. VII Certain defects in the international application**

---

The following defects in the form or contents of the international application have been noted:

see separate sheet

---

**Box No. VIII Certain observations on the international application**

---

The following observations on the clarity of the claims, description, and drawings or on the question whether the claims are fully supported by the description, are made:

see separate sheet

**Re Item V.**

1 References

Reference is made to the following documents:

- D1 WO 98/15846 A1 (ROWE DEINES INSTR INC [US]) 16 April 1998  
(1998-04-16)
- D2 US 3 618 006 A (WRIGHT CHARLES P) 2 November 1971  
(1971-11-02)
- D3 US 5 184 330 A (ADAMS JAMES W [US] ET AL) 2 February 1993  
(1993-02-02)
- D4 US 4 879 697 A (LOWRANCE DARRELL J [US] ET AL) 7  
November 1989 (1989-11-07)
- D5 US 5 694 372 A (PERENNES MARC [FR]) 2 December 1997  
(1997-12-02)

2 Independent claims 1, 32, 57 and 76

Further to a lack of clarity discussed below, the present application does not meet the criteria of Article 33(1) PCT, because the subject-matter of claims 1, 32, 57 and 76 does not involve an inventive step in the sense of Article 33(3) PCT.

- 2.1 The document D1 is regarded as being the closest prior art to the subject-matter of claim 1, and insofar as this claim can be understood, this document shows the following features thereof (the references in parentheses applying to this document):

a transducer array (abs.) comprising:

a plurality of transducer elements (fig.3), each one of the plurality of transducer elements having a substantially rectangular shape (pag. 7, l.32) configured to produce a sonar beam having a beamwidth in a direction parallel to longitudinal length of the transducer elements that is significantly less than a beamwidth of the sonar beam in a direction perpendicular to the longitudinal length of the transducer elements (fig.3 and 4), wherein the plurality of transducer elements are positioned such that longitudinal lengths of at least two of the

plurality of transducer elements are substantially parallel to each other (fig.4), and wherein the plurality of transducer elements include at least:

- i) a first linear transducer element to project sonar pulses in a first direction (fig.3),
- ii) a second linear transducer element positioned to lie substantially in a plane with the first linear transducer element and to project sonar pulses in a second direction that is generally opposite of the first side (fig.3), and
- iii) a third linear transducer element positioned to project sonar pulses in a direction substantially perpendicular to the plane (fig.3).

The subject-matter of claim 1 therefore differs from this known system in that the transducer elements are positioned within a housing.

The problem to be solved by the present invention may therefore be regarded as:

how to conveniently arrange the transducer elements of an array.

A housing is described in document D2 (see, e.g., fig.1) as providing the same advantages as in the present application. The skilled person would therefore regard it as a normal design option to include this feature in the system described in D1 in order to solve the problem posed.

Therefore, the subject-matter of independent claim 1 is not inventive in the sense of Article 33(3) PCT.

2.2 Claims 32, 57 and 76 appear to be just reformulations of claim 1. The objections raised in respect of this claim also apply, mutatis mutandis, to claims 32, 57 and 76. The subject-matter of independent claims 32, 57 and 76 is therefore not inventive (Article 33(3) PCT).

3 Dependent claims 2-31, 33-56, 58-75 and 77-99

3.1 Claims 2-31, 33-56, 58-75 and 77-99 are dependent on claims 1, 32, 57 and 76, respectively, and as such also do not meet the requirements of PCT with respect to inventive step (Article 33(3) PCT).

**Re Item VII.**



4

- 4.1 Contrary to the requirements of Rule 5.1(a)(ii) PCT, the relevant background art disclosed in documents D1, D2, D3, D4 and D5 is not mentioned in the description, nor are these documents identified therein.
- 4.2 Independent claims 1, 32, 57 and 76 are not in the two-part form in accordance with Rule 6.3(b) PCT, which in the present case would be appropriate, with those features known in combination from the prior art (document D1) being placed in the preamble (Rule 6.3(b)(I) PCT) and with the remaining features being included in the characterising part (Rule 6.3(b)(ii) PCT).
- 4.3 The features of the claims are not provided with reference signs placed in parentheses (Rule 6.2(b) PCT).

**Re Item VIII.**

5

- 5.1 Although claims 1, 32, 57 and 76 have been drafted as separate independent claims, they appear to relate effectively to the same subject-matter and to differ from each other only with regard to the definition of the subject-matter for which protection is sought and in respect of the terminology used for the features of that subject-matter. The aforementioned claims therefore lack conciseness and as such do not meet the requirements of Article 6 PCT.
- 5.2 Terms like "substantially", "significantly", "generally" used, e.g., in claim 1 and in several other claims, are unclear and leave the reader in doubt as to the meaning of the technical features to which they refer, thereby rendering the definition of the subject-matter of said claims unclear (Article 6 PCT).

## Electronic Acknowledgement Receipt

<b>EFS ID:</b>	8723494
<b>Application Number:</b>	12460139
<b>International Application Number:</b>	
<b>Confirmation Number:</b>	9769
<b>Title of Invention:</b>	Downscan imaging sonar
<b>First Named Inventor/Applicant Name:</b>	Brian T. Maguire
<b>Customer Number:</b>	00826
<b>Filer:</b>	Chad L. Thorson/Judy Creel
<b>Filer Authorized By:</b>	Chad L. Thorson
<b>Attorney Docket Number:</b>	038495/369324
<b>Receipt Date:</b>	28-OCT-2010
<b>Filing Date:</b>	14-JUL-2009
<b>Time Stamp:</b>	15:25:51
<b>Application Type:</b>	Utility under 35 USC 111(a)

### Payment information:

Submitted with Payment	no
------------------------	----

### File Listing:

Document Number	Document Description	File Name	File Size(Bytes)/ Message Digest	Multi Part /.zip	Pages (if appl.)
1		369324IDS.PDF	2493694 <small>c88baf7194bfabf222808c93bcc1ace1026284b3e</small>	yes	54

<b>Multipart Description/PDF files in .zip description</b>			
<b>Document Description</b>		<b>Start</b>	<b>End</b>
Transmittal Letter		1	1
Information Disclosure Statement (IDS) Filed (SB/08)		2	2
Foreign Reference		3	43
NPL Documents		44	54

**Warnings:**

**Information:**

<b>Total Files Size (in bytes):</b>	2493694
-------------------------------------	---------

**This Acknowledgement Receipt evidences receipt on the noted date by the USPTO of the indicated documents, characterized by the applicant, and including page counts, where applicable. It serves as evidence of receipt similar to a Post Card, as described in MPEP 503.**

**New Applications Under 35 U.S.C. 111**

**If a new application is being filed and the application includes the necessary components for a filing date (see 37 CFR 1.53(b)-(d) and MPEP 506), a Filing Receipt (37 CFR 1.54) will be issued in due course and the date shown on this Acknowledgement Receipt will establish the filing date of the application.**

**National Stage of an International Application under 35 U.S.C. 371**

**If a timely submission to enter the national stage of an international application is compliant with the conditions of 35 U.S.C. 371 and other applicable requirements a Form PCT/DO/EO/903 indicating acceptance of the application as a national stage submission under 35 U.S.C. 371 will be issued in addition to the Filing Receipt, in due course.**

**New International Application Filed with the USPTO as a Receiving Office**

**If a new international application is being filed and the international application includes the necessary components for an international filing date (see PCT Article 11 and MPEP 1810), a Notification of the International Application Number and of the International Filing Date (Form PCT/RO/105) will be issued in due course, subject to prescriptions concerning national security, and the date shown on this Acknowledgement Receipt will establish the international filing date of the application.**

**IN THE UNITED STATES PATENT AND TRADEMARK OFFICE**

In re: Brian T. Maguire  
Appl No.: 12/460,139  
Filed: July 14, 2009  
For: DOWNSCAN IMAGING SONAR

Confirmation No.: 9769  
Group Art Unit: 3662

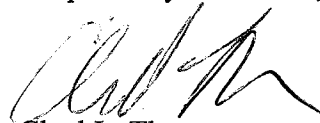
Mail Stop Amendment  
Commissioner for Patents  
P.O. Box 1450  
Alexandria, VA 22313-1450

**INFORMATION DISCLOSURE STATEMENT  
CITATION UNDER 37 C.F.R. § 1.97**

Attached is a list of documents on form PTO-1449 along with a copy of any cited foreign patent documents and non-patent literature documents in accordance with 37 CFR 1.98(a)(2).

It is requested that the Examiner consider these documents and officially make them of record in accordance with the provisions of 37 C.F.R. § 1.97 and Section 609 of the MPEP. By identifying the listed documents, Applicant in no way makes any admission as to the prior art status of the listed documents, but is instead identifying the listed documents for the sake of full disclosure.

Respectfully submitted,



Chad L. Thorson  
Registration No. 55,675

**Customer No. 00826**  
**ALSTON & BIRD LLP**  
Bank of America Plaza  
101 South Tryon Street, Suite 4000  
Charlotte, NC 28280-4000  
Tel Charlotte Office (704) 444-1000  
Fax Charlotte Office (704) 444-1111

ELECTRONICALLY FILED USING THE EFS-WEB ELECTRONIC FILING SYSTEM OF THE UNITED STATES PATENT & TRADEMARK OFFICE ON OCTOBER 28, 2010.



UNITED STATES PATENT AND TRADEMARK OFFICE

UNITED STATES DEPARTMENT OF COMMERCE
United States Patent and Trademark Office
Address: COMMISSIONER FOR PATENTS
P.O. Box 1450
Alexandria, Virginia 22313-1450
www.uspto.gov

Table with 7 columns: APPLICATION NUMBER, FILING or 371(c) DATE, GRP ART UNIT, FIL FEE REC'D, ATTY. DOCKET NO, TOT CLAIMS, IND CLAIMS. Row 1: 12/460,139, 07/14/2009, 3662, 5548, 038495/369324, 99, 4

CONFIRMATION NO. 9769

UPDATED FILING RECEIPT



826
ALSTON & BIRD LLP
BANK OF AMERICA PLAZA
101 SOUTH TRYON STREET, SUITE 4000
CHARLOTTE, NC 28280-4000

Date Mailed: 09/14/2009

Receipt is acknowledged of this non-provisional patent application. The application will be taken up for examination in due course. Applicant will be notified as to the results of the examination. Any correspondence concerning the application must include the following identification information: the U.S. APPLICATION NUMBER, FILING DATE, NAME OF APPLICANT, and TITLE OF INVENTION. Fees transmitted by check or draft are subject to collection. Please verify the accuracy of the data presented on this receipt. If an error is noted on this Filing Receipt, please submit a written request for a Filing Receipt Correction. Please provide a copy of this Filing Receipt with the changes noted thereon. If you received a "Notice to File Missing Parts" for this application, please submit any corrections to this Filing Receipt with your reply to the Notice. When the USPTO processes the reply to the Notice, the USPTO will generate another Filing Receipt incorporating the requested corrections

Applicant(s)

Brian T. Maguire, Broken Arrow, OK;

Assignment For Published Patent Application

Navico, Inc.

Power of Attorney: The patent practitioners associated with Customer Number 00826

Domestic Priority data as claimed by applicant

Foreign Applications

Permission to Access - A proper Authorization to Permit Access to Application by Participating Offices (PTO/SB/39 or its equivalent) has been received by the USPTO.

If Required, Foreign Filing License Granted: 07/28/2009

The country code and number of your priority application, to be used for filing abroad under the Paris Convention, is US 12/460,139

Projected Publication Date: 01/20/2011

Non-Publication Request: No

Early Publication Request: No

**Title**

Downscan imaging sonar

**Preliminary Class**

367

**PROTECTING YOUR INVENTION OUTSIDE THE UNITED STATES**

Since the rights granted by a U.S. patent extend only throughout the territory of the United States and have no effect in a foreign country, an inventor who wishes patent protection in another country must apply for a patent in a specific country or in regional patent offices. Applicants may wish to consider the filing of an international application under the Patent Cooperation Treaty (PCT). An international (PCT) application generally has the same effect as a regular national patent application in each PCT-member country. The PCT process **simplifies** the filing of patent applications on the same invention in member countries, but **does not result** in a grant of "an international patent" and does not eliminate the need of applicants to file additional documents and fees in countries where patent protection is desired.

Almost every country has its own patent law, and a person desiring a patent in a particular country must make an application for patent in that country in accordance with its particular laws. Since the laws of many countries differ in various respects from the patent law of the United States, applicants are advised to seek guidance from specific foreign countries to ensure that patent rights are not lost prematurely.

Applicants also are advised that in the case of inventions made in the United States, the Director of the USPTO must issue a license before applicants can apply for a patent in a foreign country. The filing of a U.S. patent application serves as a request for a foreign filing license. The application's filing receipt contains further information and guidance as to the status of applicant's license for foreign filing.

Applicants may wish to consult the USPTO booklet, "General Information Concerning Patents" (specifically, the section entitled "Treaties and Foreign Patents") for more information on timeframes and deadlines for filing foreign patent applications. The guide is available either by contacting the USPTO Contact Center at 800-786-9199, or it can be viewed on the USPTO website at <http://www.uspto.gov/web/offices/pac/doc/general/index.html>.

For information on preventing theft of your intellectual property (patents, trademarks and copyrights), you may wish to consult the U.S. Government website, <http://www.stopfakes.gov>. Part of a Department of Commerce initiative, this website includes self-help "toolkits" giving innovators guidance on how to protect intellectual property in specific countries such as China, Korea and Mexico. For questions regarding patent enforcement issues, applicants may call the U.S. Government hotline at 1-866-999-HALT (1-866-999-4158).

**LICENSE FOR FOREIGN FILING UNDER**

**Title 35, United States Code, Section 184**

**Title 37, Code of Federal Regulations, 5.11 & 5.15**

**GRANTED**

The applicant has been granted a license under 35 U.S.C. 184, if the phrase "IF REQUIRED, FOREIGN FILING LICENSE GRANTED" followed by a date appears on this form. Such licenses are issued in all applications where the conditions for issuance of a license have been met, regardless of whether or not a license may be required as

set forth in 37 CFR 5.15. The scope and limitations of this license are set forth in 37 CFR 5.15(a) unless an earlier license has been issued under 37 CFR 5.15(b). The license is subject to revocation upon written notification. The date indicated is the effective date of the license, unless an earlier license of similar scope has been granted under 37 CFR 5.13 or 5.14.

This license is to be retained by the licensee and may be used at any time on or after the effective date thereof unless it is revoked. This license is automatically transferred to any related applications(s) filed under 37 CFR 1.53(d). This license is not retroactive.

The grant of a license does not in any way lessen the responsibility of a licensee for the security of the subject matter as imposed by any Government contract or the provisions of existing laws relating to espionage and the national security or the export of technical data. Licensees should apprise themselves of current regulations especially with respect to certain countries, of other agencies, particularly the Office of Defense Trade Controls, Department of State (with respect to Arms, Munitions and Implements of War (22 CFR 121-128)); the Bureau of Industry and Security, Department of Commerce (15 CFR parts 730-774); the Office of Foreign Assets Control, Department of Treasury (31 CFR Parts 500+) and the Department of Energy.

**NOT GRANTED**

No license under 35 U.S.C. 184 has been granted at this time, if the phrase "IF REQUIRED, FOREIGN FILING LICENSE GRANTED" DOES NOT appear on this form. Applicant may still petition for a license under 37 CFR 5.12, if a license is desired before the expiration of 6 months from the filing date of the application. If 6 months has lapsed from the filing date of this application and the licensee has not received any indication of a secrecy order under 35 U.S.C. 181, the licensee may foreign file the application pursuant to 37 CFR 5.15(b).

## IN THE UNITED STATES PATENT AND TRADEMARK OFFICE

In re: Maguire  
Appl No.: 12/460,139 Confirmation No.: 9769  
Filed: July 14, 2009 Group Art Unit: 3662  
For: DOWNSCAN IMAGING SONAR

Mail Stop Missing Parts  
Commissioner for Patents  
P.O. Box 1450  
Alexandria, VA 22313-1450

## RESPONSE TO NOTICE TO FILE MISSING PARTS OF APPLICATION

In response to the Notice to File Missing Parts of Application dated July 30, 2009, enclosed are the following:

- Part 2 of Formalities Letter (not necessary when e-filing)
- Declaration and Power of Attorney for the above-identified application, which has been executed by the named inventor(s)
- Declaration of Inventors which has been executed by the named inventor(s) and an Assignee Power of Attorney
- Applicant claims small entity status
- Check in the amount of to cover the filing fee of and the surcharge under 37 C.F.R. § 1.16(f)
- All fees are being authorized to be charged to Deposit Account No. 16-0605 when electronically filing
- English Translation and \$130.00 (37 CFR 1.17(i)) fee for filing late.
- Other: Submittal of Corrected Drawings; 2 sheets of Drawings
- Any deficiency, additional fee, or credit may be charged to our Deposit Account No. 16-0605.

Respectfully submitted,



Chad L. Thorson  
Registration No. 55,675

**Customer No. 00826**  
**ALSTON & BIRD LLP**  
Bank of America Plaza  
101 South Tryon Street, Suite 4000  
Charlotte, NC 28280-4000  
Tel Charlotte Office (704) 444-1000  
Fax Charlotte Office (704) 444-1111

ELECTRONICALLY FILED USING THE EFS-WEB ELECTRONIC FILING SYSTEM OF THE UNITED STATES PATENT & TRADEMARK OFFICE ON September 1, 2009.

LEGAL02/31481244v1





UNITED STATES PATENT AND TRADEMARK OFFICE

CT

UNITED STATES DEPARTMENT OF COMMERCE  
United States Patent and Trademark Office  
Address: COMMISSIONER FOR PATENTS  
P.O. Box 1450  
Alexandria, Virginia 22313-1450  
www.uspto.gov

APPLICATION NUMBER	FILING OR 371(C) DATE	FIRST NAMED APPLICANT	ATTY. DOCKET NO./TITLE
12/460,139	07/14/2009	Brian T. Maguire	038495/369324

CONFIRMATION NO. 9769

826  
ALSTON & BIRD LLP  
BANK OF AMERICA PLAZA  
101 SOUTH TRYON STREET, SUITE 4000  
CHARLOTTE, NC.28280-4000

Alston & Bird

AUG 03 2009

FORMALITIES LETTER



OC000000037109973\*

Date Mailed: 07/30/2009

Received by \_\_\_\_\_

NOTICE TO FILE MISSING PARTS OF NONPROVISIONAL APPLICATION

FILED UNDER 37 CFR 1.53(b)

Filing Date Granted

Items Required To Avoid Abandonment:

An application number and filing date have been accorded to this application. The item(s) indicated below, however, are missing. Applicant is given **TWO MONTHS** from the date of this Notice within which to file all required items and pay any fees required below to avoid abandonment. Extensions of time may be obtained by filing a petition accompanied by the extension fee under the provisions of 37 CFR 1.136(a).

- The oath or declaration is missing.  
*A properly signed oath or declaration in compliance with 37 CFR 1.63, identifying the application by the above Application Number and Filing Date, is required.*  
*Note: If a petition under 37 CFR 1.47 is being filed, an oath or declaration in compliance with 37 CFR 1.63 signed by all available joint inventors, or if no inventor is available by a party with sufficient proprietary interest, is required.*

The application is informal since it does not comply with the regulations for the reason(s) indicated below.

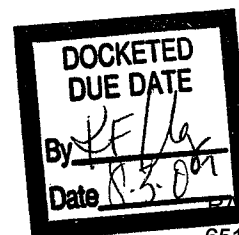
The required item(s) identified below must be timely submitted to avoid abandonment:

- Replacement drawings in compliance with 37 CFR 1.84 and 37 CFR 1.121(d) are required. The drawings submitted are not acceptable because:
  - Numbers, letters, and reference characters on the drawings must measure at least 0.32 cm (1/8 inch) in height. See Figure(s) 15B.
  - The drawings submitted to the Office are not electronically reproducible because portions of figures 15A are missing and/or blurry.

Applicant is cautioned that correction of the above items may cause the specification and drawings page count to exceed 100 pages. If the specification and drawings exceed 100 pages, applicant will need to submit the required application size f:

The applicant ne:

The required item:



- To avoid abandonment, a surcharge (for late submission of filing fee, search fee, examination fee or oath or declaration) as set forth in 37 CFR 1.16(f) of **\$130** for a non-small entity, must be submitted with the missing items identified in this notice.

**SUMMARY OF FEES DUE:**

Total additional fee(s) required for this application is **\$130** for a non-small entity

- **\$130** Surcharge.

Replies should be mailed to:

Mail Stop Missing Parts  
Commissioner for Patents  
P.O. Box 1450  
Alexandria VA 22313-1450

Registered users of EFS-Web may alternatively submit their reply to this notice via EFS-Web.

<https://sportal.uspto.gov/authenticate/AuthenticateUserLocalEPF.html>

For more information about EFS-Web please call the USPTO Electronic Business Center at **1-866-217-9197** or visit our website at <http://www.uspto.gov/ebc>.

If you are not using EFS-Web to submit your reply, you must include a copy of this notice.

/tnguyen/

---

Office of Data Management, Application Assistance Unit (571) 272-4000, or (571) 272-4200, or 1-888-786-0101

**DECLARATION AND POWER OF ATTORNEY FOR UTILITY OR DESIGN  
PATENT APPLICATION (37 CFR 1.63)**

**I hereby declare that:** (1) Each inventor's residence, mailing address, and citizenship are as stated below next to their name; and (2) I believe the inventor(s) named below to be the original and first inventor(s) of the subject matter which is claimed and for which a patent is sought on the invention entitled

**DOWNSCAN IMAGING SONAR,**

the specification of which

is attached hereto  
OR

was filed on July 14, 2009 as United States Application No. 12/460,139.

I hereby state that I have reviewed and understand the contents of the above-identified specification, including the claims, as amended by any amendment referred to above.

I acknowledge the duty to disclose information which is material to patentability as defined in 37 CFR 1.56, including for continuation-in-part applications, material information which became available between the filing date of the prior application and the national or PCT international filing date of the continuation-in-part application.

**Authorization to Permit Access To Application by Participating Offices**

If checked, the undersigned hereby grants the USPTO authority to provide the European Patent Office (EPO), the Japan Patent Office (JPO), the Korean Intellectual Property Office (KIPO), the World Intellectual Property Office (WIPO), and any other intellectual property offices in which a foreign application claiming priority to the above-identified application is filed access to the above-identified patent application. See 37 CFR 1.14(c) and (h). This box should not be checked if the applicant does not wish the EPO, JPO, or other intellectual property office in which a foreign application claiming priority to the above-identified application is filed to have access to the application.

In accordance with 37 CFR 1.14(h)(3), access will be provided to a copy of the application-as-filed with respect to: 1) the above-identified application, 2) any foreign application to which the above-identified application claims priority under 35 USC 119(a)-(d) if a copy of the foreign application that satisfies the certified copy requirement of 37 CFR 1.55 has been filed in the above-identified US application, and 3) any U.S. application from which benefit is sought in the above-identified application.

In accordance with 37 CFR 1.14(c), access may be provided to information concerning the date of filing the Authorization to Permit Access to Application by Participating Offices.

**Claim of Foreign Priority Benefits**

I hereby claim foreign priority benefits under 35 U.S.C. 119(a)-(d) or (f), or 365(b) of any foreign application(s) for patent, inventor's or plant breeder's rights certificate(s), or 365(a) of any PCT international application which designated at least one country other than the United States of America, listed below and have also identified below, by checking the box, any foreign application for patent, inventor's or plant breeder's rights certificate(s), or any PCT International application having a filing date before that of the application on which priority is claimed.

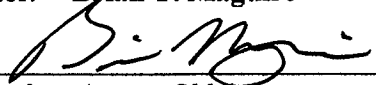
Prior Foreign Application Number(s)	Country	Foreign Filing Date (MM/DD/YYYY)	Priority Not Claimed	Certified Copy Attached?	
				Yes	No
None			<input type="checkbox"/>	<input type="checkbox"/>	<input type="checkbox"/>
			<input type="checkbox"/>	<input type="checkbox"/>	<input type="checkbox"/>

I hereby declare that all statements made herein of my own knowledge are true and that all statements made on information and belief are believed to be true; and further that these statements were made with the knowledge that willful false statements and the like so made are punishable by fine or imprisonment, or both, under 18 U.S.C. 1001 and that such willful false statements may jeopardize the validity of the application or any patent issued thereon.

**POWER OF ATTORNEY:** As a named inventor, I hereby appoint the practitioners associated with the Customer Number provided below to prosecute this application and to transact all business in the Patent and Trademark Office connected therewith, and direct that all correspondence be addressed to that Customer Number:

**Customer Number 00826**

Direct telephone calls to: Chad L. Thorson  
 Registration No. 55,675  
 Tel Charlotte Office (704) 444-1000  
 Fax Charlotte Office (704) 444-1111

Full name of sole inventor: **Brian T. Maguire**  
 Inventor's  
 Signature:  Date: 8/20/2009  
 Residence: Broken Arrow, Oklahoma  
 Citizenship: United States of America  
 Mailing Address: 4502 West Madison Pl.  
 Broken Arrow, Oklahoma 74012

LEGAL02/31399882v1

**IN THE UNITED STATES PATENT AND TRADEMARK OFFICE**

In re: Maguire  
Appl No.: 12/460,139  
Filed: July 14, 2009  
For: DOWNSCAN IMAGING SONAR

Confirmation No.: 9769  
Group Art: 3662

Mail Stop Amendment  
Commissioner for Patents  
P.O. Box 1450  
Alexandria, VA 22313-1450

**SUBMITTAL OF CORRECTED DRAWINGS UNDER  
37 CFR § 1.85(c)**

In response to the requirement for corrected drawings as set forth in Notice to File Missing Parts in the above application, there is enclosed herewith two (2) sheets of corrected drawings. It is requested that these figures be substituted for the originally filed Figs. 15A and 15B.

Respectfully submitted,



Chad L. Thorson  
Registration No. 55,675

**Customer No. 00826**  
**ALSTON & BIRD LLP**  
Bank of America Plaza  
101 South Tryon Street, Suite 4000  
Charlotte, NC 28280-4000  
Tel Charlotte Office (704) 444-1000  
Fax Charlotte Office (704) 444-1111

**ELECTRONICALLY FILED USING THE EFS-WEB ELECTRONIC FILING SYSTEM OF THE UNITED STATES PATENT & TRADEMARK OFFICE ON September 1, 2009.**

LEGAL02/31490353v1

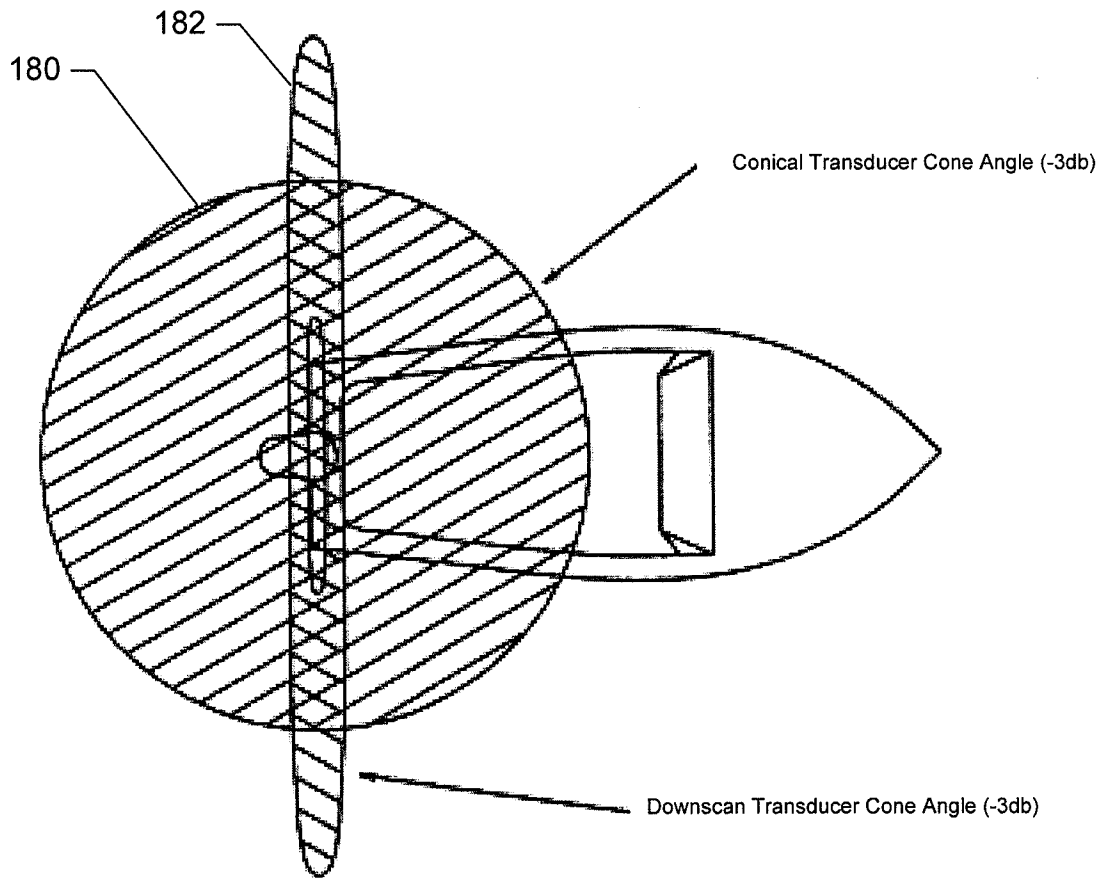
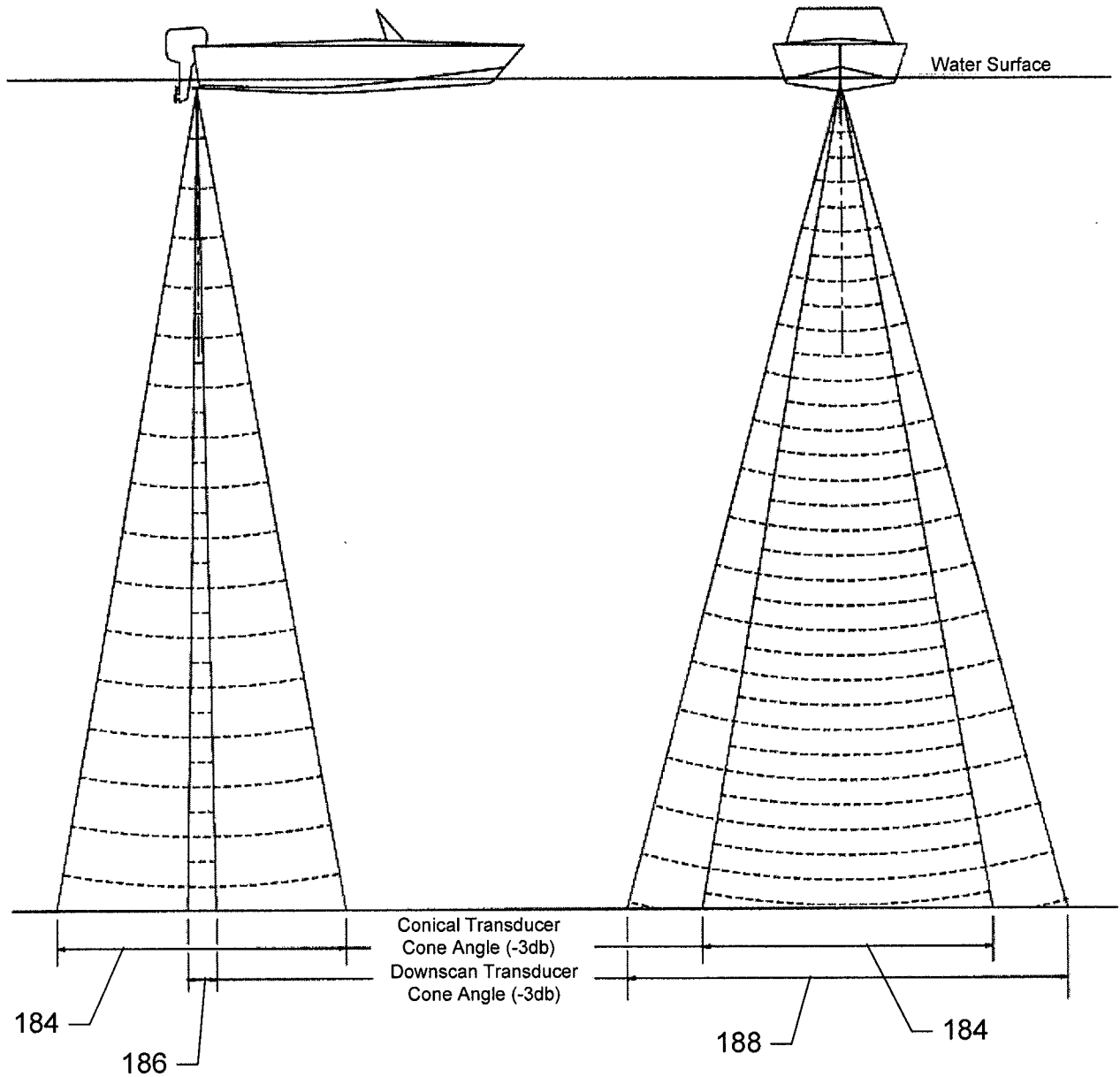


FIG. 15A.



**FIG. 15B.**

## Electronic Patent Application Fee Transmittal

<b>Application Number:</b>	12460139
<b>Filing Date:</b>	14-Jul-2009
<b>Title of Invention:</b>	Downscan imaging sonar
<b>First Named Inventor/Applicant Name:</b>	Brian T. Maguire
<b>Filer:</b>	Christopher Jason Gegg/Joyce Smith
<b>Attorney Docket Number:</b>	038495/369324

Filed as Large Entity

### Utility under 35 USC 111(a) Filing Fees

Description	Fee Code	Quantity	Amount	Sub-Total in USD(\$)
<b>Basic Filing:</b>				
<b>Pages:</b>				
<b>Claims:</b>				
<b>Miscellaneous-Filing:</b>				
Late filing fee for oath or declaration	1051	1	130	130

**Petition:**

**Patent-Appeals-and-Interference:**

**Post-Allowance-and-Post-Issuance:**

**Extension-of-Time:**



Description	Fee Code	Quantity	Amount	Sub-Total in USD(\$)
<b>Miscellaneous:</b>				
<b>Total in USD (\$)</b>				<b>130</b>

## Electronic Acknowledgement Receipt

<b>EFS ID:</b>	5993220
<b>Application Number:</b>	12460139
<b>International Application Number:</b>	
<b>Confirmation Number:</b>	9769
<b>Title of Invention:</b>	Downscan imaging sonar
<b>First Named Inventor/Applicant Name:</b>	Brian T. Maguire
<b>Customer Number:</b>	00826
<b>Filer:</b>	Christopher Jason Gegg/Joyce Smith
<b>Filer Authorized By:</b>	Christopher Jason Gegg
<b>Attorney Docket Number:</b>	038495/369324
<b>Receipt Date:</b>	01-SEP-2009
<b>Filing Date:</b>	14-JUL-2009
<b>Time Stamp:</b>	14:52:58
<b>Application Type:</b>	Utility under 35 USC 111(a)

### Payment information:

Submitted with Payment	yes
Payment Type	Deposit Account
Payment was successfully received in RAM	\$130
RAM confirmation Number	954
Deposit Account	160605
Authorized User	

The Director of the USPTO is hereby authorized to charge indicated fees and credit any overpayment as follows:

Charge any Additional Fees required under 37 C.F.R. Section 1.16 (National application filing, search, and examination fees)

Charge any Additional Fees required under 37 C.F.R. Section 1.17 (Patent application and reexamination processing fees)

RAY-1002  
660 of 737

Charge any Additional Fees required under 37 C.F.R. Section 1.19 (Document supply fees)

Charge any Additional Fees required under 37 C.F.R. Section 1.20 (Post Issuance fees)

Charge any Additional Fees required under 37 C.F.R. Section 1.21 (Miscellaneous fees and charges)

### File Listing:

Document Number	Document Description	File Name	File Size(Bytes)/ Message Digest	Multi Part /.zip	Pages (if appl.)
1		RESP369324_20090901034420.pdf	331353 42e75da9b2ff47e20458caf77e4c70cbeb37be74	yes	8

#### Multipart Description/PDF files in .zip description

Document Description	Start	End
Applicant Response to Pre-Exam Formalities Notice	1	3
Oath or Declaration filed	4	5
New or Additional Drawings	6	6
Drawings-only black and white line drawings	7	8

#### Warnings:

#### Information:

2	Fee Worksheet (PTO-875)	fee-info.pdf	29807 07fb1a6a6275658a5d8df11bd94874e6272ba88b	no	2
---	-------------------------	--------------	---	----	---

#### Warnings:

#### Information:

**Total Files Size (in bytes):** 361160

**This Acknowledgement Receipt evidences receipt on the noted date by the USPTO of the indicated documents, characterized by the applicant, and including page counts, where applicable. It serves as evidence of receipt similar to a Post Card, as described in MPEP 503.**

#### **New Applications Under 35 U.S.C. 111**

**If a new application is being filed and the application includes the necessary components for a filing date (see 37 CFR 1.53(b)-(d) and MPEP 506), a Filing Receipt (37 CFR 1.54) will be issued in due course and the date shown on this Acknowledgement Receipt will establish the filing date of the application.**

#### **National Stage of an International Application under 35 U.S.C. 371**

**If a timely submission to enter the national stage of an international application is compliant with the conditions of 35 U.S.C. 371 and other applicable requirements a Form PCT/DO/EO/903 indicating acceptance of the application as a national stage submission under 35 U.S.C. 371 will be issued in addition to the Filing Receipt, in due course.**

#### **New International Application Filed with the USPTO as a Receiving Office**

**If a new international application is being filed and the international application includes the necessary components for an international filing date (see PCT Article 11 and MPEP 1810), a Notification of the International Application Number and of the International Filing Date (Form PCT/RO/105) will be issued in due course, subject to prescriptions concerning national security, and the date shown on this Acknowledgement Receipt will establish the international filing date of the application.**



UNITED STATES PATENT AND TRADEMARK OFFICE

UNITED STATES DEPARTMENT OF COMMERCE
United States Patent and Trademark Office
Address: COMMISSIONER FOR PATENTS
P.O. Box 1450
Alexandria, Virginia 22313-1450
www.uspto.gov

Table with 4 columns: APPLICATION NUMBER (12/460,139), FILING OR 371(C) DATE (07/14/2009), FIRST NAMED APPLICANT (Brian T. Maguire), ATTY. DOCKET NO./TITLE (038495/369324)

CONFIRMATION NO. 9769

FORMALITIES LETTER



826
ALSTON & BIRD LLP
BANK OF AMERICA PLAZA
101 SOUTH TRYON STREET, SUITE 4000
CHARLOTTE, NC 28280-4000

Date Mailed: 07/30/2009

NOTICE TO FILE MISSING PARTS OF NONPROVISIONAL APPLICATION

FILED UNDER 37 CFR 1.53(b)

Filing Date Granted

Items Required To Avoid Abandonment:

An application number and filing date have been accorded to this application. The item(s) indicated below, however, are missing. Applicant is given TWO MONTHS from the date of this Notice within which to file all required items and pay any fees required below to avoid abandonment.

- The oath or declaration is missing. A properly signed oath or declaration in compliance with 37 CFR 1.63, identifying the application by the above Application Number and Filing Date, is required. Note: If a petition under 37 CFR 1.47 is being filed, an oath or declaration in compliance with 37 CFR 1.63 signed by all available joint inventors, or if no inventor is available by a party with sufficient proprietary interest, is required.

The application is informal since it does not comply with the regulations for the reason(s) indicated below.

The required item(s) identified below must be timely submitted to avoid abandonment:

- Replacement drawings in compliance with 37 CFR 1.84 and 37 CFR 1.121(d) are required. The drawings submitted are not acceptable because: Numbers, letters, and reference characters on the drawings must measure at least 0.32 cm (1/8 inch) in height. See Figure(s) 15B. The drawings submitted to the Office are not electronically reproducible because portions of figures 15A are missing and/or blurry.

Applicant is cautioned that correction of the above items may cause the specification and drawings page count to exceed 100 pages. If the specification and drawings exceed 100 pages, applicant will need to submit the required application size fee.

The applicant needs to satisfy supplemental fees problems indicated below.

The required item(s) identified below must be timely submitted to avoid abandonment:

- To avoid abandonment, a surcharge (for late submission of filing fee, search fee, examination fee or oath or declaration) as set forth in 37 CFR 1.16(f) of **\$130** for a non-small entity, must be submitted with the missing items identified in this notice.

**SUMMARY OF FEES DUE:**

Total additional fee(s) required for this application is **\$130** for a non-small entity

- **\$130** Surcharge.

Replies should be mailed to:

Mail Stop Missing Parts  
Commissioner for Patents  
P.O. Box 1450  
Alexandria VA 22313-1450

Registered users of EFS-Web may alternatively submit their reply to this notice via EFS-Web.

<https://sportal.uspto.gov/authenticate/AuthenticateUserLocalEPF.html>

For more information about EFS-Web please call the USPTO Electronic Business Center at **1-866-217-9197** or visit our website at <http://www.uspto.gov/ebc>.

If you are not using EFS-Web to submit your reply, you must include a copy of this notice.

/tnguyen/

---

Office of Data Management, Application Assistance Unit (571) 272-4000, or (571) 272-4200, or 1-888-786-0101



UNITED STATES PATENT AND TRADEMARK OFFICE

UNITED STATES DEPARTMENT OF COMMERCE
United States Patent and Trademark Office
Address: COMMISSIONER FOR PATENTS
P.O. Box 1450
Alexandria, Virginia 22313-1450
www.uspto.gov

Table with 7 columns: APPLICATION NUMBER, FILING or 371(c) DATE, GRP ART UNIT, FIL FEE REC'D, ATTY. DOCKET NO, TOT CLAIMS, IND CLAIMS. Row 1: 12/460,139, 07/14/2009, 3662, 5418, 038495/369324, 99, 4

CONFIRMATION NO. 9769

FILING RECEIPT



826
ALSTON & BIRD LLP
BANK OF AMERICA PLAZA
101 SOUTH TRYON STREET, SUITE 4000
CHARLOTTE, NC 28280-4000

Date Mailed: 07/30/2009

Receipt is acknowledged of this non-provisional patent application. The application will be taken up for examination in due course. Applicant will be notified as to the results of the examination. Any correspondence concerning the application must include the following identification information: the U.S. APPLICATION NUMBER, FILING DATE, NAME OF APPLICANT, and TITLE OF INVENTION. Fees transmitted by check or draft are subject to collection. Please verify the accuracy of the data presented on this receipt. If an error is noted on this Filing Receipt, please submit a written request for a Filing Receipt Correction. Please provide a copy of this Filing Receipt with the changes noted thereon. If you received a "Notice to File Missing Parts" for this application, please submit any corrections to this Filing Receipt with your reply to the Notice. When the USPTO processes the reply to the Notice, the USPTO will generate another Filing Receipt incorporating the requested corrections

Applicant(s)

Brian T. Maguire, Residence Not Provided;

Assignment For Published Patent Application

Navico, Inc.

Power of Attorney: None

Domestic Priority data as claimed by applicant

Foreign Applications

If Required, Foreign Filing License Granted: 07/28/2009

The country code and number of your priority application, to be used for filing abroad under the Paris Convention, is US 12/460,139

Projected Publication Date: To Be Determined - pending completion of Missing Parts

Non-Publication Request: No

Early Publication Request: No

**Title**

Downscan imaging sonar

**Preliminary Class**

367

**PROTECTING YOUR INVENTION OUTSIDE THE UNITED STATES**

Since the rights granted by a U.S. patent extend only throughout the territory of the United States and have no effect in a foreign country, an inventor who wishes patent protection in another country must apply for a patent in a specific country or in regional patent offices. Applicants may wish to consider the filing of an international application under the Patent Cooperation Treaty (PCT). An international (PCT) application generally has the same effect as a regular national patent application in each PCT-member country. The PCT process **simplifies** the filing of patent applications on the same invention in member countries, but **does not result** in a grant of "an international patent" and does not eliminate the need of applicants to file additional documents and fees in countries where patent protection is desired.

Almost every country has its own patent law, and a person desiring a patent in a particular country must make an application for patent in that country in accordance with its particular laws. Since the laws of many countries differ in various respects from the patent law of the United States, applicants are advised to seek guidance from specific foreign countries to ensure that patent rights are not lost prematurely.

Applicants also are advised that in the case of inventions made in the United States, the Director of the USPTO must issue a license before applicants can apply for a patent in a foreign country. The filing of a U.S. patent application serves as a request for a foreign filing license. The application's filing receipt contains further information and guidance as to the status of applicant's license for foreign filing.

Applicants may wish to consult the USPTO booklet, "General Information Concerning Patents" (specifically, the section entitled "Treaties and Foreign Patents") for more information on timeframes and deadlines for filing foreign patent applications. The guide is available either by contacting the USPTO Contact Center at 800-786-9199, or it can be viewed on the USPTO website at <http://www.uspto.gov/web/offices/pac/doc/general/index.html>.

For information on preventing theft of your intellectual property (patents, trademarks and copyrights), you may wish to consult the U.S. Government website, <http://www.stopfakes.gov>. Part of a Department of Commerce initiative, this website includes self-help "toolkits" giving innovators guidance on how to protect intellectual property in specific countries such as China, Korea and Mexico. For questions regarding patent enforcement issues, applicants may call the U.S. Government hotline at 1-866-999-HALT (1-866-999-4158).

**LICENSE FOR FOREIGN FILING UNDER**

**Title 35, United States Code, Section 184**

**Title 37, Code of Federal Regulations, 5.11 & 5.15**

**GRANTED**

The applicant has been granted a license under 35 U.S.C. 184, if the phrase "IF REQUIRED, FOREIGN FILING LICENSE GRANTED" followed by a date appears on this form. Such licenses are issued in all applications where the conditions for issuance of a license have been met, regardless of whether or not a license may be required as

set forth in 37 CFR 5.15. The scope and limitations of this license are set forth in 37 CFR 5.15(a) unless an earlier license has been issued under 37 CFR 5.15(b). The license is subject to revocation upon written notification. The date indicated is the effective date of the license, unless an earlier license of similar scope has been granted under 37 CFR 5.13 or 5.14.

This license is to be retained by the licensee and may be used at any time on or after the effective date thereof unless it is revoked. This license is automatically transferred to any related applications(s) filed under 37 CFR 1.53(d). This license is not retroactive.

The grant of a license does not in any way lessen the responsibility of a licensee for the security of the subject matter as imposed by any Government contract or the provisions of existing laws relating to espionage and the national security or the export of technical data. Licensees should apprise themselves of current regulations especially with respect to certain countries, of other agencies, particularly the Office of Defense Trade Controls, Department of State (with respect to Arms, Munitions and Implements of War (22 CFR 121-128)); the Bureau of Industry and Security, Department of Commerce (15 CFR parts 730-774); the Office of Foreign Assets Control, Department of Treasury (31 CFR Parts 500+) and the Department of Energy.

**NOT GRANTED**

No license under 35 U.S.C. 184 has been granted at this time, if the phrase "IF REQUIRED, FOREIGN FILING LICENSE GRANTED" DOES NOT appear on this form. Applicant may still petition for a license under 37 CFR 5.12, if a license is desired before the expiration of 6 months from the filing date of the application. If 6 months has lapsed from the filing date of this application and the licensee has not received any indication of a secrecy order under 35 U.S.C. 181, the licensee may foreign file the application pursuant to 37 CFR 5.15(b).



071409

<b>UTILITY PATENT APPLICATION TRANSMITTAL</b>  <small>(Only for new nonprovisional applications under 37 CFR 1.53(b))</small>	Attorney Docket No. 038495/369324
	First Inventor Brian T. Maguire
	Title DOWNSCAN IMAGING SONAR
	Express Mail Label No. EV339394134US

ADDRESS TO: **COMMISSIONER FOR PATENTS**  
**P.O. BOX 1450**  
**ALEXANDRIA, VA 22313-1450**

Transmitted herewith for filing in the United States Patent Office is a utility patent application.

Inventors: **Brian T. Maguire**  
Assignee of this invention is **Navico, Inc.**

1.  The Filing Fee has been calculated as shown below:  
2.  Applicant claims Small Entity Status. See 37 CFR 1.27.

		Small Entity		Large Entity		
	No. Filed	No. Extra	Rate	Fee 0	Rate	Fee 1
BASIC FEE				\$ 0		\$ 330
SEARCH FEE				\$ 0		\$ 540
EXAMINATION FEE				\$ 0		\$ 220
TOTAL CLAIMS:		99 - 20 =	79	X 26 = \$ 0		x 52 = \$ 4108
INDEP CLAIMS:		4 - 3 =	1	X 110 = \$ 0		x 220 = \$ 220
APPLICATION SIZE FEE	If the specification, drawings, and sequence listing exceed 100 sheets of paper, the application size fee due is \$270 (\$135 for small entity) for each additional 50 sheets or fraction thereof.					
<input type="checkbox"/> MULTIPLE DEPENDENT CLAIMS PRESENTED				+195 = \$		+390 = \$
*If the difference in Column 1 is less than zero, enter "0" in Column 2.			TOTAL	\$	TOTAL	\$ 5,418

The Commissioner is hereby authorized to credit overpayments or charge the following fees to Deposit Acct. No. 16-0605.

- a.  Fees required under 37 CFR 1.16 (National filing fees).  
b.  Fees required under 37 CFR 1.17 (National application processing fees) including any extension of time fees under 37 CFR § 1.136(a) that are required for consideration of papers filed during prosecution.
- A check in the amount of \$ \_\_\_ for the filing fee is enclosed.  
 Commissioner is authorized to charge the application filing fees of \$5,418.00 to Deposit Account No. 16-0605.  
 The above filing fee will be paid along with Applicant(s) Response to the Notice to File Missing Parts.
3.  Specification; Total Pages 37  
4.  23 Sheets of Drawing(s) (35 USC 113)  
5.  Declaration and Power of Attorney; [Total Pages \_\_\_]  
a.  Newly executed (original or copy)

- b.  Copy from a prior application (37 CFR 1.63(d))  
(for continuation/divisional with Box 18 completed)
  - i.  DELETION OF INVENTOR(S) Signed statement attached deleting inventor(s)  
named in the prior application, see 37 CFR 1.63(d)(2) & 1.33(b).
6.  Application Data Sheet. See 37 CFR 1.76
7.  CD-ROM or CD-R in duplicate, large table or Computer Program (Appendix)  
 Landscape Table on CD
8. Nucleotide and/or Amino Acid Sequence Submission (if applicable, all necessary)
- a.  Computer Readable Form (CRF)
  - b.  Request for Transfer of Computer Readable Form of Sequence Listing  
under 37 CFR § 1.821(e) and MPEP 2422.05 (must be compliant with new rules)
  - c.  Specification Sequence Listing on:
    - i.  CD-ROM or CD-R (2 copies); or
    - ii.  Paper
    - iii.  Electronic Text File Submission
  - d.  Statements verifying identity of above copies

**ACCOMPANYING APPLICATION PARTS**

9.  Assignment Papers (cover sheet & document(s) (including \$40.00 fee)  
Name of Assignee
10.  37 CFR 3.73(b) Statement and General Power of Attorney by Assignee. OR  
 Application Specific Power of Attorney by Assignee
11.  English Translation Document (if applicable)
12.  Information Disclosure Statement (IDS)/PTO-1449; \_\_\_ Copies of IDS Citations
13.  Preliminary Amendment
14.  Return Receipt Postcard (MPEP 503) ; Patent Application Entitled "DOWNSCAN IMAGING  
SONAR," on behalf of Inventor Brian Maguire; 23 Sheets of Drawings (3 Sets Enclosed); Petition  
to Accept Color Drawings;
15.  Certified Copy of Priority Document(s) (if foreign priority is claimed)  
 Foreign Priority is claimed as Application No. , filed
16.  Nonpublication Request under 35 U.S.C. 122(b)(2)(B)(i).  
Applicant **must** attach form PTO/SB35 or its equivalent.
17.  Other: Petition to Accept Color Drawings Under 37 C.F.R. § 1.84(a)(2)
18. **If a CONTINUING APPLICATION, check appropriate box and supply the requisite information below  
and in a preliminary amendment, or in an Application Data Sheet under 37 CFR 1.76:**  
 Continuation       Divisional       Continuation in Part (CIP)  
 of prior Application No: \_\_\_; Filed

Prior Application Information: Examiner

Group/Art Unit:

For CONTINUATION or DIVISIONAL APPS only: The entire disclosure of the prior application, from which an oath or declaration is supplied under Box 5b, is considered a part of the disclosure of the accompanying continuation or divisional application and is hereby incorporated by reference. The incorporation can only be relied upon when a portion has been inadvertently omitted from the submitted application parts.

19. **CORRESPONDENCE ADDRESS**

**CUSTOMER NUMBER 00826**

Signature: \_\_\_\_\_



Attorney/Agent of Record: Chad L. Thorson

Attorney/Agent Registration No. 55,675

**Alston & Bird LLP**

Bank of America Plaza

101 South Tryon Street, Suite 4000

Charlotte, NC 28280-4000

Tel Charlotte Office (704) 444-1000

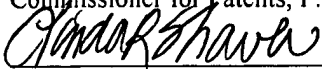
Fax Charlotte Office (704) 444-1111

"Express Mail" mailing label number EV339394134US

Date of Deposit July 14, 2009

I hereby certify that this paper or fee is being deposited with the United States Postal Service "Express Mail Post Office to Addressee" service under 37 CFR 1.10 on the date indicated above and is addressed to:

Commissioner for Patents, P.O. Box 1450, Alexandria, VA 22313-1450



\_\_\_\_\_  
Linda R. Shaver

**ELECTRONICALLY FILED USING THE EFS-WEB ELECTRONIC FILING SYSTEM OF THE UNITED STATES PATENT & TRADEMARK OFFICE ON July 14, 2009.**

071409

<b>UTILITY PATENT APPLICATION TRANSMITTAL</b>  <small>(Only for new nonprovisional applications under 37 CFR 1.53(b))</small>	Attorney Docket No. 038495/369324
	First Inventor Brian T. Maguire
	Title DOWNSCAN IMAGING SONAR
	Express Mail Label No. EV339394134US

ADDRESS TO: **COMMISSIONER FOR PATENTS**  
**P.O. BOX 1450**  
**ALEXANDRIA, VA 22313-1450**

Transmitted herewith for filing in the United States Patent Office is a utility patent application.

Inventors: **Brian T. Maguire**  
Assignee of this invention is **Navico, Inc.**

1.  The Filing Fee has been calculated as shown below:  
2.  Applicant claims Small Entity Status. See 37 CFR 1.27.

		Small Entity		Large Entity		
	No. Filed	No. Extra	Rate	Fee 0	Rate	Fee 1
BASIC FEE				\$ 0		\$ 330
SEARCH FEE				\$ 0		\$ 540
EXAMINATION FEE				\$ 0		\$ 220
TOTAL CLAIMS:		99 - 20 =	79	X 26 = \$ 0		x 52 = \$ 4108
INDEP CLAIMS:		4 - 3 =	1	X 110 = \$ 0		x 220 = \$ 220
APPLICATION SIZE FEE	If the specification, drawings, and sequence listing exceed 100 sheets of paper, the application size fee due is \$270 (\$135 for small entity) for each additional 50 sheets or fraction thereof.					
<input type="checkbox"/> MULTIPLE DEPENDENT CLAIMS PRESENTED				+195 = \$		+390 = \$
*If the difference in Column 1 is less than zero, enter "0" in Column 2.			TOTAL	\$	TOTAL	\$ 5,418

The Commissioner is hereby authorized to credit overpayments or charge the following fees to Deposit Acct. No. 16-0605.

- a.  Fees required under 37 CFR 1.16 (National filing fees).  
b.  Fees required under 37 CFR 1.17 (National application processing fees) including any extension of time fees under 37 CFR § 1.136(a) that are required for consideration of papers filed during prosecution.
- A check in the amount of \$ \_\_\_ for the filing fee is enclosed.  
 Commissioner is authorized to charge the application filing fees of \$5,418.00 to Deposit Account No. 16-0605.  
 The above filing fee will be paid along with Applicant(s) Response to the Notice to File Missing Parts.
3.  Specification; Total Pages 37  
4.  23 Sheets of Drawing(s) (35 USC 113)  
5.  Declaration and Power of Attorney; [Total Pages \_\_\_]  
a.  Newly executed (original or copy)

- b.  Copy from a prior application (37 CFR 1.63(d))  
(for continuation/divisional with Box 18 completed)
  - i.  DELETION OF INVENTOR(S) Signed statement attached deleting inventor(s)  
named in the prior application, see 37 CFR 1.63(d)(2) & 1.33(b).
6.  Application Data Sheet. See 37 CFR 1.76
7.  CD-ROM or CD-R in duplicate, large table or Computer Program (Appendix)  
 Landscape Table on CD
8. Nucleotide and/or Amino Acid Sequence Submission (if applicable, all necessary)
- a.  Computer Readable Form (CRF)
  - b.  Request for Transfer of Computer Readable Form of Sequence Listing  
under 37 CFR § 1.821(e) and MPEP 2422.05 (must be compliant with new rules)
  - c.  Specification Sequence Listing on:
    - i.  CD-ROM or CD-R (2 copies); or
    - ii.  Paper
    - iii.  Electronic Text File Submission
  - d.  Statements verifying identity of above copies

**ACCOMPANYING APPLICATION PARTS**

9.  Assignment Papers (cover sheet & document(s) (including \$40.00 fee)  
Name of Assignee
10.  37 CFR 3.73(b) Statement and General Power of Attorney by Assignee. OR  
 Application Specific Power of Attorney by Assignee
11.  English Translation Document (if applicable)
12.  Information Disclosure Statement (IDS)/PTO-1449; \_\_\_ Copies of IDS Citations
13.  Preliminary Amendment
14.  Return Receipt Postcard (MPEP 503) ; Patent Application Entitled "DOWNSCAN IMAGING  
SONAR," on behalf of Inventor Brian Maguire; 23 Sheets of Drawings (3 Sets Enclosed); Petition  
to Accept Color Drawings;
15.  Certified Copy of Priority Document(s) (if foreign priority is claimed)  
 Foreign Priority is claimed as Application No. , filed
16.  Nonpublication Request under 35 U.S.C. 122(b)(2)(B)(i).  
Applicant **must** attach form PTO/SB35 or its equivalent.
17.  Other: Petition to Accept Color Drawings Under 37 C.F.R. § 1.84(a)(2)
18. **If a CONTINUING APPLICATION, check appropriate box and supply the requisite information below  
and in a preliminary amendment, or in an Application Data Sheet under 37 CFR 1.76:**  
 Continuation       Divisional       Continuation in Part (CIP)  
 of prior Application No: \_\_\_; Filed

Prior Application Information: Examiner

Group/Art Unit:

For CONTINUATION or DIVISIONAL APPS only: The entire disclosure of the prior application, from which an oath or declaration is supplied under Box 5b, is considered a part of the disclosure of the accompanying continuation or divisional application and is hereby incorporated by reference. The incorporation can only be relied upon when a portion has been inadvertently omitted from the submitted application parts.

19. **CORRESPONDENCE ADDRESS**

**CUSTOMER NUMBER 00826**

Signature: \_\_\_\_\_



Attorney/Agent of Record: Chad L. Thorson

Attorney/Agent Registration No. 55,675

**Alston & Bird LLP**

Bank of America Plaza

101 South Tryon Street, Suite 4000

Charlotte, NC 28280-4000

Tel Charlotte Office (704) 444-1000

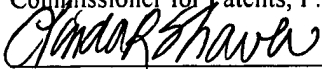
Fax Charlotte Office (704) 444-1111

"Express Mail" mailing label number EV339394134US

Date of Deposit July 14, 2009

I hereby certify that this paper or fee is being deposited with the United States Postal Service "Express Mail Post Office to Addressee" service under 37 CFR 1.10 on the date indicated above and is addressed to:

Commissioner for Patents, P.O. Box 1450, Alexandria, VA 22313-1450



\_\_\_\_\_  
Linda R. Shaver

**ELECTRONICALLY FILED USING THE EFS-WEB ELECTRONIC FILING SYSTEM OF THE UNITED STATES PATENT & TRADEMARK OFFICE ON July 14, 2009.**

## IN THE UNITED STATES PATENT AND TRADEMARK OFFICE

Appl. No.: TBD Confirmation No.: TBD  
Applicant(s): Brian Maguire  
Filed: Concurrently Herewith  
Art Unit: TBD  
Examiner: TBD  
Title: DOWNSCAN IMAGING SONAR

Docket No.: 038495/369324  
Customer No.: 00826

Mail Stop Petition  
Commissioner for Patents  
P.O. Box 1450  
Alexandria, VA 22313-1450

**PETITION TO ACCEPT COLOR DRAWINGS UNDER  
37 C.F.R § 1.84(a)(2)**

1. Applicant hereby petitions, in accordance with 37 C.F.R. § 1.84(a)(2), to have color drawings accepted in connection with the above-referenced patent application.
2. Applicant respectfully submits that color drawings are the only practical medium by which to disclose the subject matter sought to be patented in the above-referenced patent application. In this regard, Applicant respectfully submits that certain aspects of the display produced by embodiments of the above-referenced patent application can only be fully understood and appreciated when color representations of the display are viewed. In particular, FIGS. 10, 12A, 12B, 12C, 13A, 13B and 13C show details of display characteristics that exemplify the subject matter sought to be patented in a way that cannot be appreciated in black-and-white drawings.
3. Applicants have included with this petition three (3) sets of color drawings including FIGS. 10, 12A, 12B, 12C, 13A, 13B and 13C as required under 37 C.F.R. 1.84(a)(2)(ii).

Applicant: Brian Maguire

Appl. No.: TBD

Filing Date: Concurrently Herewith

4. Applicants have included in the specification, as the first paragraph of the brief description of the drawings, the following language as required under 37 C.F.R. 1.84(a)(2)(iii):
- “The patent or application file contains at least one drawing executed in color. Copies of this patent or patent application publication with color drawing(s) will be provided by the U.S. Patent and Trademark Office upon request and payment of the necessary fee.”
4. The surcharge fee set forth in § 1.17(h) required by 37 C.F.R. 1.84(a)(2)(i), is paid as follows:
- check in the amount of \$130.00
  - Charge Deposit Account 16-0605 the \$130.00
  - Charge any additional fees required by this paper or credit any overpayment to Deposit Account 16-0605.

Respectfully submitted,



Chad L. Thorson  
Registration No. 55,675

**Customer No. 000067141**  
**ALSTON & BIRD LLP**  
Bank of America Plaza  
101 South Tryon Street, Suite 4000  
Charlotte, NC 28280-4000  
Tel Charlotte Office (704) 444-1000  
Fax Charlotte Office (704) 444-1111

LEGAL02/31404417v1



## DOWNSCAN IMAGING SONAR

### FIELD OF THE INVENTION

**[0001]** Embodiments of the present invention relate generally to sonar systems, and more particularly, to providing a downscan imaging sonar using a linear transducer.

### BACKGROUND OF THE INVENTION

**[0002]** Sonar has long been used to detect waterborne or underwater objects. For example, sonar devices may be used to determine depth and bottom topography, detect fish or other waterborne contacts, locate wreckage, etc. In this regard, due to the extreme limits to visibility underwater, sonar is typically the most accurate way for individuals to locate objects underwater. Devices such as transducer elements, or simply transducers, have been developed to produce sound or vibrations at a particular frequency that is transmitted into and through the water and also to detect echo returns from the transmitted sound that return to the transducer after reflecting off an object. The transducers can convert electrical energy into sound energy and also convert sound energy (e.g., via detected pressure changes) into an electrical signal, although some transducers may act only as a hydrophone for converting sound energy into an electrical signal without having a transmitting capability. The transducers are often made using piezoelectric materials.

**[0003]** A typical transducer produces a beam pattern that emanates as a sound pressure signal from a small source such that the sound energy generates a pressure wave that expands as it moves away from the source. For instance, a circular transducer (e.g., a cylindrical shaped crystal with a circular face) typically creates a conical shaped beam with the apex of the cone being located at the source. Any reflected sound then returns to the transducer to form a return signal that may be interpreted as a surface of an object. Such transducers have often been directed in various directions from surfaced or submerged vessels in order to attempt to locate other vessels and/or the seabed for the purposes of navigation and/or target location.

**[0004]** Since the development of sonar, display technology has also been improved in order to enable better interpretation of sonar data. Strip chart recorders and other mechanical output devices have been replaced by, for example, digital displays such as LCDs (liquid crystal displays). Current display technologies continue to be improved in order to provide, for example, high quality sonar data on multi-color, high resolution displays having a more intuitive output than early sonar systems were capable of producing.

[0005] With display capabilities advancing to the point at which richly detailed information is able to be displayed, attention has turned back to the transducer in order to provide higher quality data for display. Furthermore, additional uses have been developed for sonar systems as transducer and display capabilities have evolved. For example, sonar systems have been developed to assist fishermen in identifying fish and/or the features that tend to attract fish. Historically, these types of sonar systems primarily analyzed the column of water beneath a watercraft with a cylindrical piezo element that produces a conical beam, known as a conical beam transducer or simply as a circular transducer referring to the shape of the face of the cylindrical element. However, with the advent of sidescan sonar technology, fishermen were given the capability to view not only the column of water beneath their vessel, but also view water to either side of their vessel.

[0006] Sidescan sonar can be provided in different ways and with different levels of resolution. As its name implies, sidescan sonar is directed to look to the side of a vessel and not below the vessel. In fact, many sidescan sonar systems (e.g., swath and bathymetry sonar systems) have drawn public attention for their performance in the location of famous shipwrecks and for providing very detailed images of the ocean floor, but such systems are costly and complex. Sidescan sonar typically generates a somewhat planar fan-shaped beam pattern that is relatively narrow in beamwidth in a direction parallel to the keel of a vessel deploying the sidescan sonar and is relatively wide in beamwidth in a direction perpendicular to the keel of the vessel. It may be provided in some cases using multibeam sonar systems. Such multibeam sonar systems are typically comprised of a plurality of relatively narrowly focused conventional circular transducer elements that are arrayed next to each other to produce an array of narrowly focused adjacent conical beams that together provide a continuous fan shaped beam pattern. FIG. 1 shows an example of a series of conventional (generally circular) transducer elements 10 arrayed in an arc to produce a multibeam sonar system. FIG. 2 shows a typical fan shaped beam pattern 12 produced by the multibeam sonar system of FIG. 1 as the beam pattern is projected onto the seabed.

[0007] However, multibeam sonar systems typically require very complex systems to support the plurality of transducers that are employed in order to form the multibeam sonar system. For example, a typical system diagram is shown in FIG. 3, which includes a display 20 driven by a sonar signal processor 22. The sonar signal processor 22 processes signals received from each of a plurality of transducers 26 that are fed to the sonar signal processor 22 by respective different transceivers 24 that are paired with each of the transducers 26. Thus, conventional multibeam sonar systems tend to include a large number of transceivers

and correspondingly introduce complexity in relation to processing the data such systems produce.

**[0008]** More recently, ceramic sidescan transducer elements have been developed that enable the production of a fan shaped sonar beam directed to one side of a vessel. Accordingly, the sea floor on both sides of the vessel can be covered with two elements facing on opposite sides of the vessel. These types of sidescan transducer elements are linear, rather than cylindrical, and provide a somewhat planar fan-shaped beam pattern using a single transducer to provide sidescan sonar images without utilizing the multibeam array described above. However, employment of these types of sidescan elements typically leaves the column of water beneath the vessel either un-monitored, or monitored using conical beam or circular transducers. In this regard, FIG. 4 illustrates an example of a conventional sidescan sonar with linear sidescan transducer elements oriented to produce fan-shaped beams 27 directed from opposite sides of the vessel and a conical beam 28 projecting directly below the vessel. These conical beams have conventionally been provided using conventional cylindrical transducers to produce depth information since sidescan transducers are typically not as useful for providing depth or water column feature information, such as fish targets. However, cylindrical transducers provide poor quality images for sonar data relating to the structure on the bottom or in the water column directly below the vessel.

**[0009]** Accordingly, it may be desirable to develop a sonar system that is capable of providing an improved downscan imaging sonar.

#### BRIEF SUMMARY OF THE INVENTION

**[0010]** Accordingly, embodiments of the present invention employ a linear transducer, directed downward to receive high quality images relative to the water column and bottom features directly beneath the linear transducer and the vessel on which the linear transducer is employed. Some other embodiments, in addition to the use of a linear transducer directed downward, also employ at least one sidescan transducer element (e.g., a linear transducer oriented away from the side of the vessel) to ensound (e.g., emit sonar pulses and detect echo returns) the sea floor on the sides of a vessel. Accordingly, better quality sonar images may be provided for the water column and bottom features beneath the vessel, of a quality that was unavailable earlier. Moreover, embodiments of the present invention may simplify the processing involved in producing high quality sonar images.

**[0011]** In one exemplary embodiment, a transducer array is provided. The transducer array may include a housing and a linear transducer element. The housing may be mountable

to a watercraft capable of traversing a surface of a body of water. The linear transducer element may be positioned within the housing and may have a substantially rectangular shape configured to produce a sonar beam having a beamwidth in a direction parallel to longitudinal length of the linear transducer element that is significantly less than a beamwidth of the sonar beam in a direction perpendicular to the longitudinal length of the transducer element. The linear transducer element may also be positioned within the housing to project sonar pulses in a direction substantially perpendicular to a plane corresponding to the surface.

**[0012]** In another exemplary embodiment, a transducer array is provided. The transducer array may include a plurality of transducer elements and each one of the plurality of transducer elements may include a substantially rectangular shape configured to produce a sonar beam having a beamwidth in a direction parallel to longitudinal length of the transducer elements that is significantly less than a beamwidth of the sonar beam in a direction perpendicular to the longitudinal length of the transducer elements. The plurality of transducer elements may be positioned such that longitudinal lengths of at least two of the plurality of transducer elements are parallel to each other. The plurality of transducer elements may also include at least a first linear transducer element, a second linear transducer element and a third linear transducer element. The first linear transducer element may be positioned within the housing to project sonar pulses from a first side of the housing in a direction generally perpendicular to a centerline of the housing. The second linear transducer element may be positioned within the housing to lie in a plane with the first linear transducer element and project sonar pulses from a second side of the housing that is generally opposite of the first side. The third linear transducer element may be positioned within the housing to project sonar pulses in a direction generally perpendicular to the plane.

**[0013]** In another exemplary embodiment, a sonar system is provided. The sonar system may include a transducer array and a sonar module. The transducer array may include a plurality of transducer elements and each one of the plurality of transducer elements may include a substantially rectangular shape configured to produce a sonar beam having a beamwidth in a direction parallel to longitudinal length of the transducer elements that is significantly less than a beamwidth of the sonar beam in a direction perpendicular to the longitudinal length of the transducer elements. The plurality of transducer elements may be positioned such that longitudinal lengths of at least two of the plurality of transducer elements are parallel to each other. The plurality of transducer elements may also include at least a first linear transducer element, a second linear transducer element and a third linear transducer element. The first linear transducer element may be positioned within the housing

to project sonar pulses from a first side of the housing in a direction generally perpendicular to a centerline of the housing. The second linear transducer element may be positioned within the housing to lie in a plane with the first linear transducer element and project sonar pulses from a second side of the housing that is generally opposite of the first side. The third linear transducer element may be positioned within the housing to project sonar pulses in a direction generally perpendicular to the plane. The sonar module may be configured to enable operable communication with the transducer array. The sonar module may include a sonar signal processor configured to process sonar return signals received via the transducer array, and a transceiver configured to provide communication between the transducer array and the sonar signal processor.

#### BRIEF DESCRIPTION OF THE SEVERAL VIEWS OF THE DRAWING(S)

[0014] The patent or application file contains at least one drawing executed in color. Copies of this patent or patent application publication with color drawing(s) will be provided by the U.S. Patent and Trademark Office upon request and payment of the necessary fee.

[0015] Having thus described the invention in general terms, reference will now be made to the accompanying drawings, which are not necessarily drawn to scale, and wherein:

[0016] FIG. 1 is a diagram illustrating an example of a series of conventional transducer elements 10 arrayed to produce a multibeam sonar system;

[0017] FIG. 2 illustrates a fan shaped beam pattern produced by the conventional multibeam sonar system of FIG. 1 as the beam pattern is projected onto the seabed;

[0018] FIG. 3 is a block diagram of a conventional multibeam sonar system for the system shown in FIG. 1;

[0019] FIG. 4 is a diagram illustrating a conventional sidescan sonar system;

[0020] FIG. 5 is a basic block diagram illustrating a sonar system according to an exemplary embodiment of the present invention;

[0021] FIG. 6 is a diagram illustrating a more detailed view of a transducer array according to an exemplary embodiment of the present invention;

[0022] FIG. 7A illustrates a side view showing a beam pattern produced by the transducer array according to an exemplary embodiment of the present invention;

[0023] FIG. 7B illustrates a top view showing a beam pattern produced by the transducer array according to an exemplary embodiment of the present invention;

[0024] FIG. 8A is a diagram illustrating a cross section of components in a containment volume of a housing according to an exemplary embodiment of the present invention;

[0025] FIG. 8B is a diagram illustrating a cross section of components in a containment volume of a housing according to another exemplary embodiment of the present invention;

[0026] FIG. 9A shows an example of beam coverage for an 800 kHz operating frequency in one exemplary embodiment of the present invention;

[0027] FIG. 9B shows an example of beam coverage for a 455 kHz operating frequency in one exemplary embodiment of the present invention;

[0028] FIG. 10A illustrates a projection, onto a substantially flat sea bed, of the beam pattern of an exemplary transducer array providing gaps between fan shaped beams produced by a transducer array in which transducer elements are positioned to provide coplanar beams with gaps therebetween according to an exemplary embodiment of the present invention;

[0029] FIG. 10B illustrates a projection, onto a substantially flat sea bed, of the beam pattern of an exemplary transducer array providing gaps between the fan shaped beams produced by a transducer array in which the transducer elements are positioned to provide gaps with planar separation therebetween according to another exemplary embodiment of the present invention;

[0030] FIG. 11A shows an example of a view of the beam coverage associated with the exemplary embodiment of FIG. 9A in which the beam coverage is extended to the bottom of a flat bottomed body of water according to an exemplary embodiment of the present invention;

[0031] FIG. 11B illustrates example sidescan images that may be produced based on data from sidescan beams shown in FIG. 11A according to an exemplary embodiment of the present invention;

[0032] FIG. 11C illustrates example linear downscan images that may be produced based on data from linear downscan beams shown in FIG. 11A according to an exemplary embodiment of the present invention;

[0033] FIG. 12A illustrates example sidescan images that may be produced based on data from sidescan beams;

[0034] FIG. 12B illustrates a side-by-side comparison of images produced by a downscan linear transducer element according to an exemplary embodiment and a corresponding conical downscan image;

[0035] FIG. 12C illustrates another side-by-side comparison of images produced by a downscan linear transducer element according to an exemplary embodiment and a corresponding conical downscan image;

[0036] FIG. 12D illustrates still another side-by-side comparison of images produced by a downscan linear transducer element according to an exemplary embodiment and a corresponding conical downscan image;

[0037] FIG. 12E illustrates yet another side-by-side comparison of images produced by a downscan linear transducer element according to an exemplary embodiment and a corresponding conical downscan image;

[0038] FIG. 12F illustrates yet still another side-by-side comparison of images produced by a downscan linear transducer element according to an exemplary embodiment and a corresponding conical downscan image;

[0039] FIG. 13A is a diagram illustrating an example of a sea bottom structure viewed through a linear downscan transducer element according to an exemplary embodiment;

[0040] FIG. 13B is a diagram illustrating an example of a fan shaped beam from a linear downscan transducer compared to a conical beam from a cylindrical transducer for the sea bottom structure illustrated in FIG. 13A according to an exemplary embodiment;

[0041] FIG. 14 is a basic block diagram illustrating a sonar system according to an exemplary embodiment of the present invention;

[0042] FIG. 15A illustrates an example of a top view of the beam overlap that may occur in situations where a linear downscan transducer and a circular downscan transducer are employed according to an exemplary embodiment of the present invention;

[0043] FIG. 15B shows side views of the same beam overlap shown in FIG. 15A from the starboard side of a vessel and from ahead of the bow of the vessel according to an exemplary embodiment of the present invention;

[0044] FIG. 16A is a diagram showing a perspective view of a linear downscan transducer and a circular downscan transducer within a single housing from a point above the housing according to an exemplary embodiment of the present invention;

[0045] FIG. 16B is a perspective view from one side of the housing of FIG. 16A at a point substantially perpendicular to a longitudinal axis of the housing according to an exemplary embodiment of the present invention;

[0046] FIG 16C is a perspective view from the front side of the housing of FIG. 16A at a point looking straight down the longitudinal axis of the housing according to an exemplary embodiment of the present invention;

[0047] FIG. 17A is a diagram showing a perspective view of a linear downscan transducer within a single housing from a point above the housing according to an exemplary embodiment of the present invention;

[0048] FIG. 17B is a perspective view from one side of the housing of FIG. 17A at a point substantially perpendicular to a longitudinal axis of the housing according to an exemplary embodiment of the present invention; and

[0049] FIG 17C is a perspective view from the front side of the housing of FIG. 17A at a point looking straight down the longitudinal axis of the housing according to an exemplary embodiment of the present invention.

#### DETAILED DESCRIPTION OF THE INVENTION

[0050] Exemplary embodiments of the present invention now will be described more fully hereinafter with reference to the accompanying drawings, in which some, but not all embodiments of the invention are shown. Indeed, the invention may be embodied in many different forms and should not be construed as limited to the exemplary embodiments set forth herein; rather, these embodiments are provided so that this disclosure will satisfy applicable legal requirements. Like reference numerals refer to like elements throughout.

[0051] FIG. 5 is a basic block diagram illustrating a sonar system 30 for use with multiple exemplary embodiments of the present invention. As shown, the sonar system 30 may include a number of different modules or components, each of which may comprise any device or means embodied in either hardware, software, or a combination of hardware and software configured to perform one or more corresponding functions. For example, the sonar system 30 may include a sonar signal processor 32, a transceiver 34 and a transducer array 36 and/or numerous other peripheral devices such as one or more displays 38. One or more of the modules may be configured to communicate with one or more of the other modules to process and/or display data, information or the like from one or more of the modules. The modules may also be configured to communicate with one another in any of a number of different manners including, for example, via a network 40. In this regard, the network 40 may be any of a number of different communication backbones or frameworks including, for example, Ethernet, the NMEA 2000 framework or other suitable networks.

[0052] The display 38 may be configured to display images and may include or otherwise be in communication with a user interface 39 configured to receive an input from a user. The display 38 may be, for example, a conventional LCD (liquid crystal display), a touch screen display, or any other suitable display known in the art upon which images may be rendered. Although each display 38 of FIG. 5 is shown as being connected to the sonar signal processor 32 via the network and/or via an Ethernet hub, the display 38 could alternatively be in direct



communication with the sonar signal processor 32 in some embodiments, or the display 38, sonar signal processor 32 and user interface 39 could be in a single housing. The user interface 39 may include, for example, a keyboard, keypad, function keys, mouse, scrolling device, input/output ports, touch screen, or any other mechanism by which a user may interface with the system. Moreover, in some cases, the user interface 39 may be a portion of one or more of the displays 38.

**[0053]** The transducer array 36 according to an exemplary embodiment may be provided in one or more housings that provide for flexible mounting with respect to a hull of the vessel on which the sonar system 30 is employed. In this regard, for example, the housing may be mounted onto the hull of the vessel or onto a device or component that may be attached to the hull (e.g., a trolling motor or other steerable device, or another component that is mountable relative to the hull of the vessel), including a bracket that is adjustable on multiple axes, permitting omnidirectional movement of the housing. The transducer array 36 may include one or more transducer elements positioned within the housing, as described in greater detail below, and each of the transducer elements may be configured to be directed to cover a different area such that one transducer element covers one side of the vessel with a fan shaped beam, another transducer element covers the opposite side of the vessel with a fan shaped beam, and the third fan shaped beam covers a region between the other transducer elements directed below the vessel. In an exemplary embodiment, each of the transducer elements of the transducer array 36 may be substantially identical in terms of construction and therefore may be different only by virtue of the orientation of the respective transducer elements. The transducer array 36 may be configured to both transmit and receive sound pressure waves. However, in some cases, the transducer array 36 could include separate elements for transmission and reception. The transducer array 36 is described in greater detail below in reference to FIG. 6.

**[0054]** In an exemplary embodiment, the sonar signal processor 32, the transceiver 34 and an Ethernet hub 42 or other network hub may form a sonar module 44. As such, for example, in some cases, the transducer array 36 may simply be placed into communication with the sonar module 44, which may itself be a mobile device that may be placed (but not necessarily mounted in a fixed arrangement) in the vessel to permit easy installation of one or more displays 38, each of which may be remotely located from each other and operable independent of each other. In this regard, for example, the Ethernet hub 42 may include one or more corresponding interface ports for placing the network 40 in communication with each display 38 in a plug-n-play manner. As such, for example, the Ethernet hub 42 may not only

include the hardware needed to enable the displays 38 to be plugged into communication with the network 40 via the Ethernet hub 42, but the Ethernet hub 42 may also include or otherwise be in communication with software modules for providing information to enable the sonar module 44 to communicate with one or more different instances of the display 38 that may or may not be the same model or type of display and that may display the same or different information. In other words, the sonar module 44 may store configuration settings defining a predefined set of display types with which the sonar module is compatible so that if any of the predefined set of display types are placed into communication with the sonar module 44, the sonar module 44 may operate in a plug-n-play manner with the corresponding display types. Accordingly, the sonar module 44 may include a memory storing device drivers accessible to the Ethernet hub 42 to enable the Ethernet hub 42 to properly work with displays for which the sonar module 44 is compatible. The sonar module 44 may also be enabled to be upgraded with additional device drivers to enable expansion of the numbers and types of devices with which the sonar module 44 may be compatible. In some cases, the user may select a display type to check whether a the display type is supported and, if the display type is not supported, contact a network entity to request software and/or drivers for enabling support of the corresponding display type.

**[0055]** The sonar signal processor 32 may be any means such as a device or circuitry operating in accordance with software or otherwise embodied in hardware or a combination of hardware and software (e.g., a processor operating under software control or the processor embodied as an application specific integrated circuit (ASIC) or field programmable gate array (FPGA) specifically configured to perform the operations described herein, or a combination thereof) thereby configuring the device or circuitry to perform the corresponding functions of the sonar signal processor 32 as described herein. In this regard, the sonar signal processor 32 may be configured to analyze electrical signals communicated thereto by the transceiver 34 to provide sonar data indicative of the size, location, shape, etc. of objects detected by the sonar system 30. In some cases, the sonar signal processor 32 may include a processor, a processing element, a coprocessor, a controller or various other processing means or devices including integrated circuits such as, for example, an ASIC, FPGA or hardware accelerator, that is configured to execute various programmed operations or instructions stored in a memory device. The sonar signal processor may further or alternatively embody multiple compatible additional hardware or hardware and software items to implement signal processing or enhancement features to improve the display characteristics or data or images, collect or process additional data, such as time, temperature,

GPS information, waypoint designations, or others, or may filter extraneous data to better analyze the collected data. It may further implement notices and alarms, such as those determined or adjusted by a user, to reflect depth, presence of fish, proximity of other watercraft, etc. Still further, the processor, in combination with suitable memory, may store incoming transducer data or screen images for future playback or transfer, or alter images with additional processing to implement zoom or lateral movement, or to correlate data, such as fish or bottom features to a GPS position or temperature. In an exemplary embodiment, the sonar signal processor 32 may execute commercially available software for controlling the transceiver 34 and/or transducer array 36 and for processing data received therefrom. Further capabilities of the sonar signal processor 32 and other aspects related to the sonar module are described in U.S. Patent Application Serial No. \_\_\_\_\_, entitled "Linear and Circular Downscan Imaging Sonar" filed on even date herewith, the disclosure of which is incorporated herein by reference in its entirety.

[0056] The transceiver 34 may be any means such as a device or circuitry operating in accordance with software or otherwise embodied in hardware or a combination of hardware and software (e.g., a processor operating under software control or the processor embodied as an ASIC or FPGA specifically configured to perform the operations described herein, or a combination thereof) thereby configuring the device or circuitry to perform the corresponding functions of the transceiver 34 as described herein. In this regard, for example, the transceiver 34 may include circuitry for providing transmission electrical signals to the transducer array 36 for conversion to sound pressure signals based on the provided electrical signals to be transmitted as a sonar pulse. The transceiver 34 may also include circuitry for receiving electrical signals produced by the transducer array 36 responsive to sound pressure signals received at the transducer array 36 based on echo or other return signals received in response to the transmission of a sonar pulse. The transceiver 34 may be in communication with the sonar signal processor 32 to both receive instructions regarding the transmission of sonar signals and to provide information on sonar returns to the sonar signal processor 32 for analysis and ultimately for driving one or more of the displays 38 based on the sonar returns.

[0057] FIG. 6 is a diagram illustrating a more detailed view of the transducer array 36 according to an exemplary embodiment. As shown in FIG. 6, the transducer array 36 may include a housing 50 that may include mounting holes 52 through which screws, rivets, bolts or other mounting devices may be passed in order to fix the housing 50 to a mounting bracket, a device attached to a vessel or to the hull of the vessel itself. However, in some cases, the housing 50 may be affixed by welding, adhesive, snap fit or other coupling means.

The housing 50 may be mounted to a portion of the vessel, or to a device attached to the vessel, that provides a relatively unobstructed view of both sides of the vessel. Thus, for example, the housing 50 may be mounted on or near the keel (or centerline) of the vessel, on a fixed or adjustable mounting bracket that extends below a depth of the keel (or centerline) of the vessel, or on a mounting device that is offset from the bow or stern of the vessel. The housing 50 may include a recessed portion defining containment volume 54 for holding transducer elements 60. The recessed portion defining the containment volume may extend away from the hull of the vessel on which the housing 50 is mounted and therefore protrude into the water on which the vessel operates (or in which the vessel operates in a case where the transducer array 36 is mounted to a tow fish). To prevent cavitation or the production of bubbles due to uneven flow over the housing 50, the housing 50 (and in particular the containment volume portion of the housing) may have a gradual, rounded or otherwise streamlined profile to permit laminar flow of water over the housing 50. In some examples, an insulated cable 58 may provide a conduit for wiring to communicatively couple the transducer elements 60 to the sonar module 44.

[0058] Each of the transducer elements 60 may be a linear transducer element. Thus, for example, each of the transducer elements 60 may be substantially rectangular in shape and made from a piezoelectric material such as a piezoelectric ceramic material, as is well known in the art and may include appropriate shielding (not shown) as is well known in the art. The piezoelectric material being disposed in a rectangular arrangement provides for an approximation of a linear array having beamwidth characteristics that are a function of the length and width of the rectangular face of the transducer elements and the frequency of operation. In an exemplary embodiment, the transducer elements 60 may be configured to operate in accordance with at least two operating frequencies. In this regard, for example, a frequency selection capability may be provided by the sonar module 44 to enable the user to select one of at least two frequencies of operation. In one example, one operating frequency may be set to about 800 kHz and another operating frequency may be set to about 455 kHz. Furthermore, the length of the transducer elements may be set to about 120 mm while the width is set to about 3 mm to thereby produce beam characteristics corresponding to a bearing fan of about 0.8 degrees by about 32 degrees at 800 kHz or about 1.4 degrees by about 56 degrees at 455 kHz. However, in general, the length and width of the transducer elements 60 may be set such that the beamwidth of sonar beam produced by the transducer elements 60 in a direction parallel to a longitudinal length (L) of the transducer elements 60 is less than about five percent as large as the beamwidth of the sonar beam in a direction (w)

perpendicular to the longitudinal length of the transducer elements 60. (See generally FIGS. 7A, 7B, 9A, 9B.) It should be noted that although the widths of various beams are shown and described herein, the widths being referred to do not necessarily correspond to actual edges defining limits to where energy is placed in the water. As such, although beam patterns and projections of beam patterns are generally shown herein as having fixed and typically geometrically shaped boundaries, those boundaries merely correspond to the -3dB (or half power) points for the transmitted beams. In other words, energy measured outside of the boundaries shown is less than half of the energy transmitted. Thus, the boundaries shown are merely theoretical half power point boundaries.

**[0059]** Although dual frequency operations providing a specific beam fan for each respective element for given lengths are described above, it should be understood that other operating ranges could alternatively be provided with corresponding different transducer element sizes and corresponding different beamwidth characteristics. Moreover, in some cases, the sonar module 44 may include a variable frequency selector, to enable an operator to select a particular frequency of choice for the current operating conditions. However, in all cases where the longitudinal length of the transducer elements 60 is generally aligned with the centerline of the vessel, the rectangular shape of the transducer elements 60 provides for a narrow beamwidth in a direction substantially parallel to the centerline of the vessel and wide beamwidth in a direction substantially perpendicular to the centerline of the vessel.

However, if the transducer array 36 is mounted in a different fashion or to a rotatable accessory on the vessel (e.g., a trolling motor mount), the fan-shaped beams produced will have the wide beamwidth in a direction substantially perpendicular to the longitudinal length of the transducer elements 60 and a narrow beamwidth in a direction substantially parallel to the longitudinal length of the transducer elements 60. Thus, the sonar could also be oriented to provide fore and aft oriented fan-shaped beams or any other orientation relative to the vessel in instances where motion of the vessel is not necessarily in a direction aligned with the centerline of the vessel.

**[0060]** FIGS. 7A and 7B show side and top views, respectively, illustrating the beam characteristics produced by an exemplary embodiment of the present invention. In this regard, FIG. 7A illustrates a side view showing the transducer array 36 mounted to a bracket that extends from the aft end of the centerline of the vessel (e.g., boat). As shown in FIG. 7A, the beam produced by the transducer array 36 is relatively narrow in the direction substantially parallel to the centerline of the vessel if the transducer elements are aligned for a generally coplanar beam. FIG. 7A also includes a cutaway view of the transducer array 36 to

show the orientation of the transducer elements 60 in context relative to the vessel according to this example. Meanwhile, FIG. 7B shows a top view of the beam produced by the transducer assembly 36 if the transducer elements are aligned for a generally coplanar beam. As shown in FIG. 7B, the beam produced by the transducer array is relatively wide in the direction substantially perpendicular to the centerline of the vessel thereby producing a fan-shaped beam pattern extending out to both sides and also covering the water column beneath the vessel, as described below. FIG. 7B also includes a cutaway view of the transducer array 36 to show the orientation of the transducer elements 60 in context relative to the vessel according to this example.

**[0061]** FIG. 8A is a diagram illustrating a cross section of components in the containment volume 54 according to an exemplary embodiment. In particular, FIG. 8A illustrates the arrangement of the linear transducer elements 60 within the containment volume 54. The transducer elements 60, which may include a port side element 62 positioned to scan substantially to the port side of the vessel, a starboard side element 64 positioned to scan substantially to the starboard side of the vessel, and a downscan element 66 positioned to scan substantially below the vessel. As shown in FIG. 8A, in an exemplary embodiment, both the port side element 62 and the starboard side element 64 may be oriented to face slightly below a surface of the water on which the vessel travels. In one example, both the port side element 62 and the starboard side element 64 may be oriented such that the widest dimension of the beamwidth of each respective element is centered at 30 degrees below a plane substantially parallel to the surface of the water. Meanwhile, the downscan linear element 66 may be positioned such that the widest dimension of the beamwidth of the downscan element 66 is centered at 90 degrees below the plane substantially parallel to the surface of the water. In other words, the downscan element 66 has the central portion of its fan shape aimed straight down. The containment volume 54 may include electrical connections (not shown) to communicate with the transceiver 34 and supports, struts, rods or other supporting structures to secure each of the linear transducer elements 60 in their respective orientations. The transducer elements 60 may be held in place or otherwise affixed to the supporting structures via adhesive or any other suitable joining material and the angles at which the transducer elements 60 are affixed relative to each other and to the housing 50 may vary as necessary or as desired.

**[0062]** FIG. 8B is a diagram illustrating a cross section of components in the containment volume 54 according to an alternative exemplary embodiment. In this regard, FIG. 8B illustrates the arrangement of one linear transducer element 60 within the containment

volume 54. The transducer element 60 according to this exemplary embodiment is a single linear transducer (e.g., downscan element 66) positioned to scan substantially below the vessel. As shown in FIG. 8B, the downscan element 66 may be positioned such that the widest dimension of the beamwidth of the downscan element 66 is centered at 90 degrees below the plane substantially parallel to the surface of the water. In other words, the downscan element 66 has the central portion of its fan shape aimed substantially straight down. As discussed above, the containment volume 54 may include electrical connections (not shown) to communicate with the transceiver 34 and supports, struts, rods or other supporting structures to secure the downscan element 66 in its respective orientation. The linear downscan element 66 may be held in place or otherwise affixed to the supporting structures via adhesive or any other suitable joining material such that transmissions produced by the downscan element 66 exit the housing 50 substantially at a 90 degree angle with respect to the plane of the face of the downscan element 66 from which the transmissions emanate.

[0063] FIG. 9A shows an example of beam coverage for an 800 kHz operating frequency in one exemplary embodiment. As such, the beamwidth (e.g., width between the half power points) of each of the three linear transducer elements 60 is about 32 degrees. FIG. 9B shows an example of beam coverage for a 455 kHz operating frequency in one exemplary embodiment, thereby providing about 56 degrees of beamwidth for each of the three linear transducer elements 60. Accordingly, in each of the exemplary embodiments of FIGS. 9A and 9B, the three fan-shaped segments together produce a discontinuous fan shaped beam. The discontinuity may be minimized in some instances by selection of transducer element dimensions and operating frequencies selected to minimize the size of the gaps (e.g., zones with sonar beam coverage outside of beam coverage area as defined by the half power points of the beams) between the beams of the transducer elements. Alternatively, the physical orientation of the transducer elements 60 with respect to each other could be changed in order to minimize the size of the gaps. However, it should be noted that in most cases some gap should be maintained in order to prevent interference between the beam patterns emanating from the linear transducer elements 60. Although the fan-shaped segments of an exemplary embodiment may all lie in the same plane, it may be desirable to alter the orientation of one or more of the transducer elements 60 such that a corresponding one or more of the fan-shaped segments is outside of the plane of the other fan-shaped segments. The gap could therefore be provided via planar separation of the fan-shaped segments rather than by providing separation between the segments within the same plane.

[0064] In this regard, FIG. 10A illustrates a projection, onto a substantially flat sea bed, of the beam pattern of an exemplary transducer array providing gaps between the boundaries of the projections as defined by the half power points defining fan shaped beams produced by a transducer array in which the transducer elements 60 are positioned to provide coplanar beams with gaps therebetween according to an exemplary embodiment. As such, a first transducer element beam projection 100, a second transducer element beam projection 102 and a third transducer element beam projection 104 are all shown lying in the same plane in FIG. 10A. Meanwhile, FIG. 10B illustrates a projection, onto a substantially flat sea bed, of the beam pattern of an exemplary transducer array providing gaps between the fan shaped beams produced by a transducer array in which the transducer elements 60 are positioned to provide gaps with planar separation therebetween according to another exemplary embodiment. Thus, the first transducer element beam projection 100', the second transducer element beam projection 102' and the third transducer element beam projection 104' are shown lying in different planes in FIG. 10B. Notably, in each of FIGS. 10A and 10B, the view is shown from the top looking down onto the sea bed and the beam projections are not necessarily to scale.

[0065] FIG. 11A shows an example of a view of the beam coverage associated with the embodiment of the example shown in FIG. 9A in which the beam coverage is extended to the bottom of a flat bottomed body of water. The illustration of FIG. 11A shows a view looking at the stern of a vessel 70 as the vessel 70 is driving away from the viewer (e.g., into the page). According to this example, a port sidescan beam 72 (e.g., that may be produced by port sidescan element 62) extends out to the port side of the vessel 70 providing coverage of the bottom from point A to point B. Meanwhile, a starboard sidescan beam 74 (e.g., that may be produced by starboard sidescan element 64) extends out to the starboard side of the vessel 70 from point C to point D. Additionally, a downscan beam 76 (e.g., that may be produced by downscan element 66) extends directly below the vessel 70 from point E to point F. As shown in FIG. 11A, the coverage areas defined between points A and B and points C and D are substantially larger than the coverage area defined between points E and F. Based on the increased bottom coverage, the display provided responsive to data received in the sidescan beams 72 and 74 will be different than the display provided responsive to data received in the downscan beam 76. FIGS. 11B and 11C show examples of images that may correspond to the beam coverage areas shown in FIG. 11A. In this regard, for example, FIG. 11B illustrates possible images that could correspond to the region defined between points A and B and



points C and D (e.g., sidescan images), while FIG. 11C illustrates a possible image that may correlate to the coverage area between points E and F (e.g., a linear downscan image).

[0066] FIGS. 12A through 12F show examples of images that may be produced by embodiments of the present invention to illustrate differences between the display produced by a linear downscan element of an embodiment of the present invention and either a sidescan or a conventional circular downscan transducer element. In this regard, FIG. 12A illustrates an example image that may be produced based on data from the sidescan beams 72 and 74. For this example, assume the top of the display (identified by arrow 80) shows the most recent data (e.g., corresponding to the vessel's current position) and the bottom of the display (identified by arrow 82) shows the oldest data. Additionally, the right side of the display 84 may correspond to the starboard sidescan beam 74 while the left side of the display 86 corresponds to the port sidescan beam 72. Brighter pixels illustrated in FIG. 12A correspond to return data received in the corresponding sidescan beams. In this regard, data closest to dashed line 88 corresponds to the data gathered near point B (for the left side of the display 86) and near point D (for the right side of the display 84) and data at the left edge of the display corresponds to data gathered near point A while data at the right edge of the display corresponds to data gathered near point C over the time period from the position of arrow 82 to the position of arrow 80. Thus, well over 50% of the display of FIG. 12A (and in many cases 100%) is utilized to show data corresponding to bottom features, e.g. the topography of and structures attached to the bottom, that have provided return data from the sidescan beams 72 and 74. By comparison only a small portion (e.g., less than 20%) of the display shows any water column features, e.g., data from the water column between the vessel 70 and the portions of the bottom covered by each respective sidescan beam. The sidescan beams 72 and 74 also fail to provide depth data. Still further, the sidescan beams fail to provide depth data or bottom feature data or water column data for that portion of the bottom beneath the vessel, e.g., that portion between reference points B and D and the vessel 70 in FIG 11.

[0067] FIGS. 12B through 12F show on the right side (e.g., right display 90) of each figure, exemplary screen shots of a conventional circular downscan transducer image that corresponds to the display (e.g., the left side of each figure (left display 92)) produced by the linear downscan element of an embodiment of the present invention (e.g., downscan element 66). In this regard, the left display of FIG. 12B shows a boulder on the left, two tree trunks rising up from the bottom near the center of the display, and, possibly, several fish (white spots) near the lower right. The corresponding same features can be vaguely determined

from the right display 90 (i.e., the circular downscan display), but the images are much less clear. Similarly, FIGS. 12C, 12D and 12E clearly show very detailed images of trees rising vertically from the bottom in the left display 92, while such features are very difficult to distinguish on the right display 90. FIG. 12F clearly shows a downed tree and at least two vertical trees nearby in the left display 92, whereas the same features are difficult to discern in the right display 90.

[0068] The exemplary linear downscan image on the left side of FIG. 12B includes a numerical depth scale 0-40 on the right side, with sonar reflection data being represented on the display screen at the time-dependent depth using known sonar imaging practices. Boat position is represented by the numeral 0, or some other desirable icon, for the most recent sonar pings, and the oldest sonar pings are presented by the left side of the screen, presenting a scrolling image as the boat (and transducer) move across the water surface over time. The far right column reflects the intensity of the return echo received at the circular downscan transducer, plotted adjacent the 0-40 depth scale.

[0069] Accordingly, by placing a linear transducer in a downward oriented position, a much improved image quality is achieved for bottom data and structures attached to it or rising above it relative to the conventional circular downscan sonar. In this regard, while sidescan images are valued for their ability to provide detailed images of laterally distant bottom features, they are unable to provide depth data or bottom data or water column data below the vessel. A linear downscan element provides the unexpected advantage of providing detailed images of the water column below the vessel (e.g., upwardly extending submerged trees, fish, etc.), as well as details of the features of the bottom or structures resting on or rising above the bottom (e.g., rocks, crevices, submerged trees, sunken objects, etc.), and a depth indication that can be registered (e.g., feet or meters). For example, again referring to the left image of FIG. 12B, the mass of bright pixels at about 30 feet (as indicated by the numbers in increments of five feet that extend down the right edge of the left display 92) represent bottom feature data and are indicative of the depth at which the bottom is encountered. The bottom feature data may also, in some cases, indicate the type of bottom (e.g., rocky, muddy, hard, soft, flat, sloped, smooth, rough, etc.). Thus, sonar returns associated with the bottom in a linear downscan display are not only indicative of bottom features, but are also indicative of depth and water column data. However, the bottom feature data represents a relatively small percentage of the overall display area. Due to the relatively small percentage of display area that is devoted to bottom feature data, a relatively large percentage of the display area may be devoted to other data, e.g., data representing the water

column above the bottom). Thus, for example, as shown in FIG. 12B, water column features are represented by data including a boulder and trees extending from the bottom along with any suspended objects (e.g., schools of bait fish, individual large fish, etc.), thermoclines, and other features may be displayed in greater detail along with the indication of bottom depth. Meanwhile, even in situations where the zoom level of the display is not set such that the lake or sea bottom is near the lowest portion of the display (such as in FIG. 12C), the bottom features only account for a small percentage of the display area, while the water column features account for more than 50% and the area below the lake or sea bottom is essentially featureless.

[0070] FIGS. 12B through 12F each show far less than 50% (and typically less than 20%) of the display being utilized to show data corresponding to bottom features, and do so for the water column beneath the vessel. As shown, a linear transducer positioned as a downscan element (e.g., downscan element 66) according to an exemplary embodiment, is capable of providing far more information regarding the water column itself rather than merely the bottom features or depth. Thus, water column data can be received and displayed representing schools of fish, individual fish and certain structural features in the water column directly below the vessel 70. Additionally, as shown in FIGS. 12B through 12F, a linear transducer positioned as a downscan element is also capable of producing depth data. In this regard, whereas a sidescan image produces relatively high quality images of bottom features (see for example, FIG. 12A), it is unable to produce useful depth data or water column data. A downscan image produced by a linear transducer according to an exemplary embodiment of the present invention produces depth data along with bottom feature data and water column data.

[0071] FIG. 13A provides an example of a display of the bottom structure as viewed through use of a linear downscan sonar element (e.g., downscan element 66) of an exemplary embodiment of the present invention. FIG. 13B shows the vessel 70 and various bottom features viewed from above. The bottom features include a boulder 120, a vertical tree 122, a rock pile 124, a school of fish 126 and a fallen, horizontal tree 128. FIG. 13B also shows a linear transducer downscan fan-shaped sonar beam 130 projected onto the bottom as compared to a circular transducer downscan conical beam 132 projected onto the bottom. As can be appreciated from the corresponding example display provided in FIG. 13A, since the linear downscan beam 130 has a narrow aspect in one direction and a broad aspect in the other, the amount of data received and therefore processed for display is less with respect to each feature for which a return is received than for the conical beam 132. There is typically

no overlap in coverage from each outgoing sound wave to the next (ping to ping) in the linear downscan beam 130 whereas there will be such overlap in the conical beam 132. Thus, while data corresponding to the conical beam 132 is processed, it produces blurred images due to the additional return data received. The linear downscan beam 130 is able to produce “cleaner” images that more accurately illustrate feature data that reflects what objects are in the water column and on the bottom beneath the vessel. Note, however, that there can be at least partial overlap in the bottom topography that is sonified by the linear and circular transducer, as shown in FIG. 13B.

**[0072]** By providing the downscan element 66 as a linear transducer element of the same type and construction as one or both of the port side linear element 62 and the starboard side linear element 64, embodiments of the present invention provide vivid images of the column of water over which the vessel passes in addition to providing vivid images of the water column on both sides of the vessel, which is provided by conventional sidescan sonar systems that either neglect the column of water beneath the vessel or only scan such region with a conical beam from a transducer element having a cylindrical shape that is not capable of providing the level of detail provided by embodiments of the present invention. Moreover, embodiments of the present invention provide high quality images of the column of water over which the vessel passes without the high degree of complexity and cost associated with a multibeam system.

**[0073]** FIG. 14 illustrates an exemplary sonar system incorporating linear and circular downscan transducers 140, 142. The two transducers may be in the same or separate housings. They typically utilize different operational frequencies. Such may also assist in minimizing interference. Similar to the system illustrated in FIG. 5, the transducers are operationally connected to the transceivers 144, 146, which configure the transducer outputs for receipt by the sonar signal processor 148. The sonar signal processor executes various programs stored or as may be selected by the user interface 150. The Ethernet hub 152, network 154, displays 156 and user interface 150 operate as described for the corresponding components of FIG 5. The image processor 158 may perform a variety of functions to optimize or customize the display images, including such features as split screen to show multiple different sonar images or data. Examples include individual and separate images of GPS, waypoints, mapping, nautical charts, GPS tracking, radar, etc., which are typically shown side-by-side or stacked. Additional examples include individual data boxes, such as speed, depth, water, temperature, range or distance scales, location or waypoint, latitude, longitude, time, etc. Still further examples include composite images that combine

information from one or more of these sources, such as the images from the linear downstream and circular downstream transducers to overlay the images. For example, the traditional "fish arch" image representing a possible fish using a circular downscan sonar may be imposed over a small white circle or oval representing a possible fish using a linear downscan sonar. Still further, one image may be colorized to distinguish it visibly from data representing another image. As such, for example, the images may be combined using image blending or overlay techniques. Alternatively, individual images may be presented, or different images, simultaneously on different displays without overlay. Image data packets or streams may also have additional data associated therewith, such as time of day, location, temperature, speed, GPS, etc.

[0074] Notably, the example of FIG. 14 may be simplified in some embodiments. In this regard, the radar, map and GPS modules of FIG. 14 along with the Ethernet hub 152 may not be included in some embodiments. Moreover, in one example, an embodiment of the present invention may include essentially only processing circuitry to handle inputs from a linear and circular transducer array along with a display in a single device. As such, for example, all of the electronics for handling linear and circular transducer inputs may be included along with a display within a single box, without any Ethernet connection or other peripherals.

[0075] FIG. 15A illustrates an example of a top view of the beam overlap that may occur in situations where a linear downscan transducer and a circular downscan transducer are employed simultaneously. FIG. 15B shows side views of the same beam overlap shown in FIG. 15A from the starboard side of a vessel (on the left side of the page) and from ahead of the bow of the vessel (on the right side of the page). As shown in FIG. 15A, there is overlap between a conical beam projection 180 showing an example coverage area of a beam produced by the circular downscan transducer and a downscan beam projection 182 showing an example coverage area of a beam produced by the linear downscan transducer. The differences between the beam patterns of the linear and circular downscan transducers are further illustrated in FIG. 15B in which it can be seen that the beamwidth 184 of the beam produced by the circular downscan transducer is substantially the same regardless of the side from which the beam is viewed. However, the beamwidth 186 of the beam produced by the linear downscan transducer as viewed from the starboard side of the vessel is substantially smaller than the beamwidth 188 of the beam produced by the linear downscan transducer as viewed from ahead of the bow of the vessel. Moreover, the beamwidth 188 is wider than the beamwidth 184, while the beamwidth 186 is narrower than the beamwidth 184.

[0076] FIGS. 16A through 16C illustrate diagrams of a linear downscan transducer 190 and a circular downscan transducer 192 within a single streamlined housing 194 from various different perspectives. In this regard, FIG. 16A is a perspective view from above the housing 194. Meanwhile, FIG. 16B is a perspective view from one side of the housing 194 at a point substantially perpendicular to a longitudinal axis of the housing 194 and FIG 16C is a perspective view from the front side of the housing 194 at a point looking straight down the longitudinal axis of the housing 194. As shown in FIGS. 16A-16C, the linear downscan transducer 190 and the circular downscan transducer 192 may each be disposed to be in planes that are substantially parallel with each other and with a plane in which the longitudinal axis of the housing 194 lies. Generally speaking, the linear downscan transducer 190 and the circular downscan transducer 192 may also be disposed in line with the longitudinal axis of the housing 194. Although shown in a particular order in FIGS. 16A-16C, the ordering of the placement of the linear downscan transducer 190 and the circular downscan transducer 192 within the housing 194 may be reversed in some examples. Furthermore, in some cases, the linear downscan transducer 190 and the circular downscan transducer 192 may each be located in their own respective separate housings rather than both being within a single housing. FIGS. 16A-16C also illustrate an example of a mounting device 196 for mounting the housing 194 to a vessel.

[0077] By way of comparison, FIGS. 17A through 17C illustrate diagrams of a single linear downscan transducer 190 a housing 198 from various different perspectives. In this regard, FIG. 17A is a perspective view from above the housing 198. Meanwhile, FIG. 17B is a perspective view from one side of the housing 198 at a point substantially perpendicular to a longitudinal axis of the housing 198 and FIG 17C is a perspective view from the front side of the housing 198 at a point looking straight down the longitudinal axis of the housing 198. As shown in FIGS. 17A-17C, by employing only the linear downscan transducer 190 the size of the housing 198 may be reduced. In this regard, for example, particularly FIG. 17C shows a reduction in the cross sectional size of the housing 198 as compared to the cross sectional size of the housing 194 of FIG. 16C. Thus, for example, the housing 198 may introduce less drag than the housing 194.

[0078] Many modifications and other embodiments of the inventions set forth herein will come to mind to one skilled in the art to which these embodiments pertain having the benefit of the teachings presented in the foregoing descriptions and the associated drawings. Therefore, it is to be understood that the inventions are not to be limited to the specific embodiments disclosed and that modifications and other embodiments are intended to be

included within the scope of the appended claims. Although specific terms are employed herein, they are used in a generic and descriptive sense only and not for purposes of limitation.

THAT WHICH IS CLAIMED:

1. A transducer array comprising:

a plurality of transducer elements, each one of the plurality of transducer elements having a substantially rectangular shape configured to produce a sonar beam having a beamwidth in a direction parallel to longitudinal length of the transducer elements that is significantly less than a beamwidth of the sonar beam in a direction perpendicular to the longitudinal length of the transducer elements,

wherein the plurality of transducer elements are positioned such that longitudinal lengths of at least two of the plurality of transducer elements are substantially parallel to each other, and

wherein the plurality of transducer elements include at least:

a first linear transducer element positioned within a housing to project sonar pulses from a first side of the housing in a direction substantially perpendicular to a centerline of the housing,

a second linear transducer element positioned within the housing to lie substantially in a plane with the first linear transducer element and project sonar pulses from a second side of the housing that is generally opposite of the first side, and

a third linear transducer element positioned within the housing to project sonar pulses in a direction substantially perpendicular to the plane.

2. The transducer array of claim 1, wherein the first linear transducer element is positioned to project sonar pulses defining a beamwidth having a center forming about a 30 degree angle with respect to the plane, and wherein the second is also positioned to project sonar pulses defining a beamwidth having a center forming about a 30 degree angle with respect to the plane.

3. The transducer array of claim 1, wherein at least one transducer within the transducer array is configured to operate at a selected one of at least two selectable operating frequencies.

4. The transducer array of claim 3, wherein the selectable operating frequencies include about 455 kHz and 800 kHz.



5. The transducer array of claim 1, wherein the beamwidth of each of the transducer elements is about 0.8 degrees by about 32 degrees or about 1.4 degrees by about 56 degrees.
6. The transducer array of claim 1, wherein beams produced by each of the first, second and third transducers do not overlap with each other.
7. The transducer array of claim 1, wherein the transducer array includes a housing mountable to a watercraft and wherein the plurality of transducer elements are each positioned within the housing.
8. The transducer array of claim 7, wherein the watercraft operates on a surface of a body of water.
9. The transducer array of claim 7, wherein the watercraft is a submersible vehicle.
10. The transducer array of claim 1, wherein the transducer array is configured to communicate with a single transceiver.
11. The transducer array of claim 1, wherein a length of a rectangular face of each of the transducer elements is about 120 mm and a width of the rectangular face of each of the transducer elements is about 3 mm.
12. The transducer array of claim 1, wherein the beamwidth in the direction parallel to longitudinal length of the transducer elements is less than about five percent as large as the beamwidth of the sonar beam in the direction perpendicular to the longitudinal length of the transducer elements.
13. The transducer array of claim 1, wherein respective sonar beams produced by each of the first, second and third linear transducer elements provide substantially continuous sonar coverage from one side of a vessel on which the housing is mounted to an opposite side of the vessel by providing planar separation between at least one fan-shaped beam segment

produced by one of the transducer elements and at least one other fan-shaped beam segment produced by another of the transducer elements.

14. The transducer array of claim 1, wherein the plurality of transducer elements are positioned such that longitudinal lengths of each of the plurality of transducer elements are substantially parallel to each other.

15. The transducer array of claim 1, wherein the housing is mountable to a vessel to generate sonar pulses defining a fan-shaped beam extending from one side of the vessel to an opposite side of the vessel.

16. The transducer array of claim 1, wherein the housing is mountable to a vessel to generate sonar pulses defining a fan-shaped beam extending from a forward end of the vessel to an after end of the vessel.

17. The transducer array of claim 1, wherein the first, second or third linear transducer elements are positioned side by side with respect to each other.

18. The transducer array of claim 1, wherein the first, second or third linear transducer elements are positioned collinear with respect to each other.

19. The transducer array of claim 1, wherein the third linear transducer element is positioned substantially between the first and second transducer elements.

20. The transducer array of claim 1, wherein the housing has a streamlined shape.

21. The transducer array of claim 1, wherein the third linear transducer element generates signals representing depth data.

22. The transducer array of claim 1, wherein the third linear transducer element generates signals representing water column data.

23. The transducer array of claim 1 wherein the third linear transducer element generates signals representing bottom data.

24. The transducer array of claim 1 wherein the third linear transducer element generates signals representing two or more of depth data, water column data and bottom data.

25. The transducer array of claim 1 wherein the third linear transducer element generates signals representing data vertically below the third transducer element.

26. The transducer array of claim 1, wherein the plurality of transducer elements further comprises a circular transducer element producing a conical downscan beam.

27. The transducer array of Claim 26 wherein the sonar pulses from the third linear transducer element and the sonar pulses from the circular transducer element sonify areas of the bottom that at least partially overlap.

28. The sonar system of Claim 26 wherein the sonar signal returns from the circular transducer element and third linear downscan element provide generally simultaneous data.

29. The transducer array of Claim 1 further comprising shielding proximate predetermined surfaces of at least one of the transducer elements to minimize signal interference.

30. The transducer array of Claim 1 further comprising an omnidirectional bracket for adapting said array for adjustable directional mounting.

31. The transducer array of Claim 26 wherein the circular transducer element produces a conical beam from within the housing.

32. A sonar system comprising:  
a transducer array including a plurality of transducer elements having a substantially rectangular shape configured to produce a sonar beam having a beamwidth in a direction parallel to longitudinal length of the transducer elements that is significantly less than a beamwidth of the sonar beam in a direction perpendicular to the longitudinal length of the transducer elements,

wherein the plurality of transducer elements are positioned such that longitudinal lengths of at least two of the plurality of transducer elements are substantially parallel to each other, and

wherein the plurality of transducer elements include at least:

a first linear transducer element positioned within a housing to project sonar pulses from a first side of the housing in a direction substantially perpendicular to a centerline of the housing,

a second linear transducer element positioned within the housing to lie substantially in a plane with the first linear transducer element and project sonar pulses from a second side of the housing that is substantially opposite of the first side, and

a third linear transducer element positioned within the housing to project sonar pulses in a direction substantially perpendicular to the plane; and

a sonar module configured to enable operable communication with the transducer array, the sonar module including:

a sonar signal processor to process sonar return signals received via the transducer array, and

a transceiver configured to provide communication between the transducer array and the sonar signal processor.

33. The sonar system of claim 32, wherein the sonar module further comprises an Ethernet hub in communication with the signal processor.

34. The sonar system of claim 32, wherein the sonar module is provided within a single housing.

35. The sonar system of claim 34, wherein the housing has a streamlined shape.

36. The sonar system of claim 32 further comprising at least one visual display presenting an image representing the processed sonar return signals.

37. The sonar system of claim 36, wherein the display and the sonar module are in the same housing.

38. The sonar system of claim 36, wherein at least one display of the plurality of displays is enabled to simultaneously provide different images representing different information from the processed sonar return signals.

39. The sonar system of claim 32, wherein the sonar module further comprises configuration settings defining a predefined set of display images that may be presented.

40. The sonar system of claim 32, wherein the first linear transducer element is positioned to project sonar pulses defining a beamwidth having a center forming about a 30 degree angle with respect to the plane, and wherein the second linear transducer element is also positioned to project sonar pulses defining a beamwidth having a center forming about a 30 degree angle with respect to the plane.

41. The sonar system of claim 32, wherein the transducer array is configured to operate at a selected one of at least two selectable operating frequencies.

42. The sonar system of claim 41, wherein the selectable operating frequencies include about 455 kHz and 800 kHz.

43. The sonar system of claim 32, wherein beams produced by each of the first, second and third linear transducers do not overlap with each other.

44. The sonar system of claim 32, wherein the transducer array includes the housing being mountable to a watercraft and wherein the plurality of transducer elements are each positioned within the housing.

45. The sonar system of claim 32, wherein the housing is mountable to a vessel to generate sonar pulses defining a fan-shaped beam extending from one side of the vessel to an opposite side of the vessel.

46. The sonar system of claim 32, wherein the transceiver comprises a single transceiver configured to provide communication between the plurality of transducer elements of the transducer array and the sonar signal processor.

47. The sonar system of claim 32, wherein the sonar signal processor is configured to display images of sonar data in which images corresponding to data received via the first and second linear transducers provide data regarding bottom features over greater than about fifty percent of a display screen when displayed and images corresponding to data received via the third linear transducer provide data regarding bottom features over less than fifty percent of a display screen when displayed.

48. The sonar system of claim 32, wherein the sonar signal processor is configured to display images of sonar data corresponding to data received via the third linear transducer representing bottom data.

49. The sonar system of claim 32, wherein the sonar signal processor is configured to display images of sonar data corresponding to data received via the third linear transducer representing water column data.

50. The sonar system of claim 32, wherein the sonar signal processor is configured to display images of sonar data corresponding to data received via the third linear transducer representing depth data.

51. The sonar system of claim 32, wherein the sonar signal processor is configured to display images of sonar data corresponding to data received via the third linear transducer representing two or more of depth data, water column data and bottom data.

52. The sonar system of Claim 32 wherein the sonar signal processor is configured to display images of sonar data corresponding to data received via the third transducer element representing data vertically below the third transducer.

53. The sonar system of Claim 32 further comprising a circular transducer element producing a conical downscan beam.

54. The sonar system of Claim 32 further comprising a circular transducer element producing a conical downscan beam from within the housing.

55. The sonar system of Claim 53 wherein the sonar pulses from the third linear transducer element and the sonar pulses from the circular transducer element sonify areas of the bottom that at least partially overlap.

56. The sonar system of Claim 53 wherein the sonar signal returns from the circular transducer element and third linear downscan element provide generally simultaneous data.

57. A transducer array comprising:  
a housing mountable to a watercraft capable of traversing a surface of a body of water; and  
a linear transducer element positioned within the housing, the linear transducer element having a substantially rectangular shape configured to produce a sonar beam having a beamwidth in a direction parallel to longitudinal length of the linear transducer element that is significantly less than a beamwidth of the sonar beam in a direction perpendicular to the longitudinal length of the transducer element,  
wherein the linear transducer element is positioned within the housing to project sonar pulses in a direction substantially perpendicular to a plane corresponding to the surface.

58. The transducer array of claim 57, wherein the linear transducer element is configured to operate at a selected one of at least two selectable operating frequencies.

59. The transducer array of claim 57, wherein the selectable operating frequencies include about 455 kHz and 800 kHz.

60. The transducer array of claim 57, wherein the beamwidth of the linear transducer element is about 0.8 degrees by about 32 degrees or about 1.4 degrees by about 56 degrees.

61. The transducer array of claim 57, wherein the transducer array is configured to communicate with a single transceiver.

62. The transducer array of claim 57; wherein a length of a rectangular face of the linear transducer element is about 120 mm and a width of the rectangular face of the linear transducer element is about 3 mm.

63. The transducer array of claim 57, wherein the housing is mountable to a vessel to generate sonar pulses defining a fan-shaped beam extending from one side of the vessel to an opposite side of the vessel.

64. The transducer array of claim 57, wherein the housing has a streamlined shape.

65. The transducer array of claim 57, wherein the beamwidth in the direction parallel to longitudinal length of the linear transducer element is less than about five percent as large as the beamwidth of the sonar beam in the direction perpendicular to the longitudinal length of the linear transducer element.

66. The transducer array of claim 57, wherein the linear transducer element is configured to provide data displayable as sonar data images in which images corresponding to data received via the linear transducer provide data regarding bottom features over less than fifty percent of a display screen when displayed.

67. The transducer array of claim 57, wherein the linear transducer element is configured to provide data displayable as sonar data images in which images corresponding to data received via the linear transducer provide data regarding bottom features over less than twenty percent of a display screen when displayed.

68. The transducer array of claim 57, wherein the linear transducer element is configured to provide data displayable as sonar data images in which images corresponding to data received via the linear transducer provide data indicative of bottom depth.

69. The transducer array of claim 57, wherein the linear transducer element is configured to provide data displayable as sonar data images in which images corresponding to data received via the linear transducer provide data indicative of water column features.

70. The transducer array of Claim 57, wherein the linear transducer element is configured to provide data displayable as sonar data images indicative of bottom data.



71. The transducer array of Claim 57, wherein the linear transducer element is configured to provide data displayable as sonar data images indicative of two or more of depth data water column data and bottom data.

72. The transducer array of Claim 57, further comprising a circular transducer element positioned to project conical sonar pulses in a direction substantially perpendicular to the plane corresponding to the surface.

73. The transducer array of Claim 72, wherein the linear and circular transducer elements are in the same housing.

74. The transducer array of Claim 72, wherein the linear transducer and circular transducer elements are positioned to project fan-shaped and conical sonar beams that at least partially overlap.

75. The transducer array of claim 72, wherein the sonar signal returns from the circular transducer element and linear transducer element provide generally simultaneous data.

76. A sonar system comprising:

a linear transducer element positioned within a housing, the linear transducer element having a substantially rectangular shape configured to produce a sonar beam having a beamwidth in a direction parallel to longitudinal length of the linear transducer element that is significantly less than a beamwidth of the sonar beam in a direction perpendicular to the longitudinal length of the transducer element,

wherein the linear transducer element is positioned to project sonar pulses in a direction substantially perpendicular to a plane corresponding to the surface of a body of water;

a sonar module configured to enable operable communication with the transducer array, the sonar module including:

a sonar signal processor to process sonar return signals received via the linear transducer element, and

at least one transceiver configured to provide communication between the linear transducer element and the sonar signal processor.

77. The sonar system of claim 76, wherein the sonar module further comprises an Ethernet hub in communication with the signal processor.

78. The sonar system of claim 76, wherein the sonar module is provided within a separate housing.

79. The sonar system of claim 76, further comprising at least one visual display presenting an image representing the processed sonar return signals.

80. The sonar system of claim 79, wherein the display and the sonar module are in the same housing.

81. The sonar system of claim 79, wherein at least one display of the plurality of displays is enabled to simultaneously provide different images representing different information from the processed sonar return signals.

82. The sonar system of claim 76, wherein the sonar module further comprises configuration settings defining a predefined set of display images that may be presented.

83. The sonar system of claim 76, wherein the linear transducer element is configured to operate at a selected one of at least two selectable operating frequencies.

84. The sonar system of claim 76, wherein the selectable operating frequencies include about 455 kHz and 800 kHz.

85. The sonar system of claim 76, wherein the linear transducer element is positioned within a housing being mountable to a watercraft.

86. The sonar system of claim 85, wherein the housing is mountable to a vessel to generate sonar pulses defining a fan-shaped beam extending from one side of the vessel to an opposite side of the vessel.

87. The sonar system of claim 85, wherein the housing is mountable to a watercraft capable of traversing a surface of a body of water.

88. The sonar system of claim 76, wherein the sonar signal processor is configured to display images of sonar data in which images corresponding to data received via the linear transducer provide data regarding bottom features over less than fifty percent of a display screen when displayed.

89. The sonar system of claim 76, wherein the sonar signal processor is configured to display images of sonar data corresponding to data received via the linear transducer element representing bottom data.

90. The sonar system of claim 76, wherein the sonar signal processor is configured to display images of sonar data corresponding to data received via the linear transducer element representing water column data.

91. The sonar system of claim 76, wherein the sonar signal processor is configured to display images of sonar data corresponding to data received via the linear transducer element representing depth data.

92. The sonar system of claim 76, wherein the sonar signal processor is configured to display images of sonar data corresponding to data received via the linear transducer element representing two or more of depth data, water column data and bottom data.

93. The sonar system of claim 76, wherein the sonar signal processor is configured to display images of sonar data corresponding to data received via the linear transducer element representing data vertically below the linear transducer element.

94. The sonar system of claim 76, further comprising a circular transducer element producing a conical downscan beam.

95. The sonar system of claim 76, further comprising a circular transducer element producing a conical downscan beam from within the housing.

96. The sonar system of claim 94, wherein the sonar pulses from the linear transducer element and the sonar pulses from the circular transducer element sonify areas of the bottom that at least partially overlap.

97. The sonar system of claim 94, wherein the sonar signal returns from the circular transducer element and linear downscan element provide generally simultaneous data.

98. The sonar system of claim 76, further comprising sources of data from at least one of the group of radar, GPS, digital mapping, time and temperature.

99. The sonar system of claim 98, wherein a display format for display of the data is in a user selectable format.

## ABSTRACT OF THE DISCLOSURE

A downscan imaging sonar utilizes a linear transducer element to provide improved images of the sea floor and other objects in the water column beneath a vessel. A transducer array may include a plurality of transducer elements and each one of the plurality of transducer elements may include a substantially rectangular shape configured to produce a sonar beam having a beamwidth in a direction parallel to longitudinal length of the transducer elements that is significantly less than a beamwidth of the sonar beam in a direction perpendicular to the longitudinal length of the transducer elements. The plurality of transducer elements may be positioned such that longitudinal lengths of at least two of the plurality of transducer elements are parallel to each other. The plurality of transducer elements may also include at least a first linear transducer element, a second linear transducer element and a third linear transducer element. The first linear transducer element may be positioned within the housing to project sonar pulses from a first side of the housing in a direction substantially perpendicular to a centerline of the housing. The second linear transducer element may be positioned within the housing to lie in a plane with the first linear transducer element and project sonar pulses from a second side of the housing that is substantially opposite of the first side. The third linear transducer element may be positioned within the housing to project sonar pulses in a direction substantially perpendicular to the plane.

## ARTIFACT SHEET

Enter artifact number below. Artifact number is application number + artifact type code (see list below) + sequential letter (A, B, C ...). The first artifact folder for an artifact type receives the letter A, the second B, etc.. Examples: 59123456PA, 59123456PB, 59123456ZA, 59123456ZB

**12460139CA**

Indicate quantity of a single type of artifact received but not scanned. Create individual artifact folder/box and artifact number for each Artifact Type.

CD(s) containing:

computer program listing

Doc Code: Computer

pages of specification

and/or sequence listing

and/or table

Doc Code: Artifact

content unspecified or combined

Doc Code: Artifact

Artifact Type Code: P

Artifact Type Code: S

Artifact Type Code: U

Stapled Set(s) Color Documents or B/W Photographs

Doc Code: Artifact    Artifact Type Code: C

Microfilm(s)

Doc Code: Artifact    Artifact Type Code: F

Video tape(s)

Doc Code: Artifact    Artifact Type Code: V

Model(s)

Doc Code: Artifact    Artifact Type Code: M

Bound Document(s)

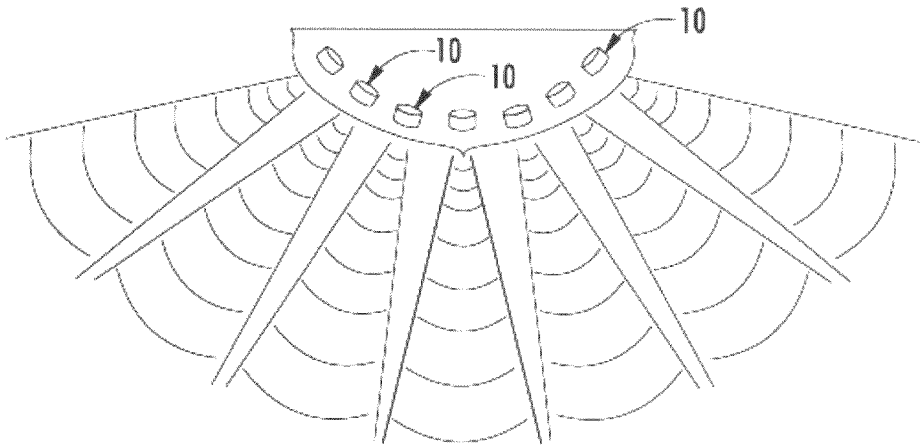
Doc Code: Artifact    Artifact Type Code: B

Confidential Information Disclosure Statement or Other Documents marked Proprietary, Trade Secrets, Subject to Protective Order, Material Submitted under MPEP 724.02, etc.

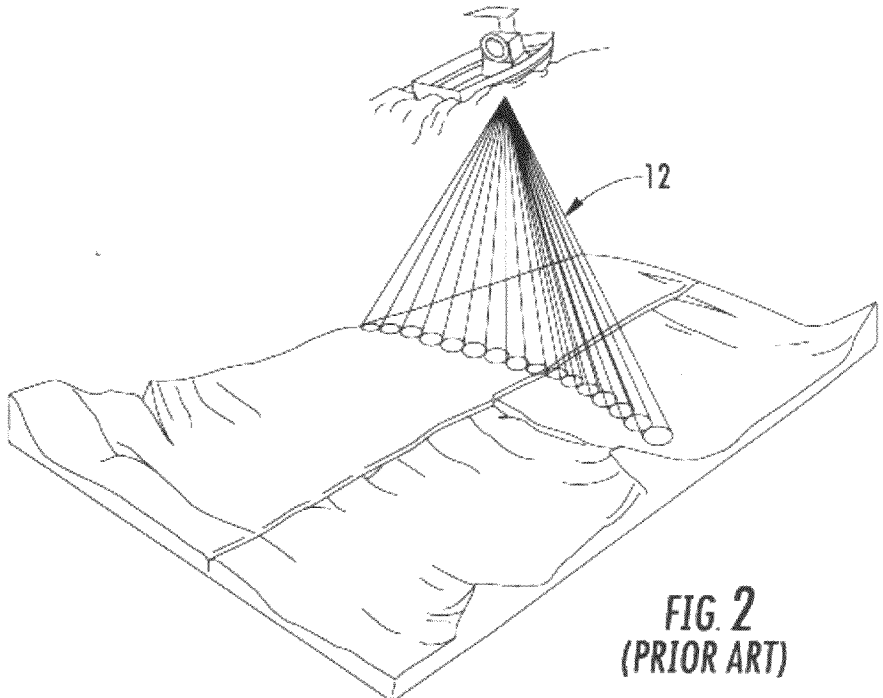
Doc Code: Artifact    Artifact Type Code X

Other, description: \_\_\_\_\_

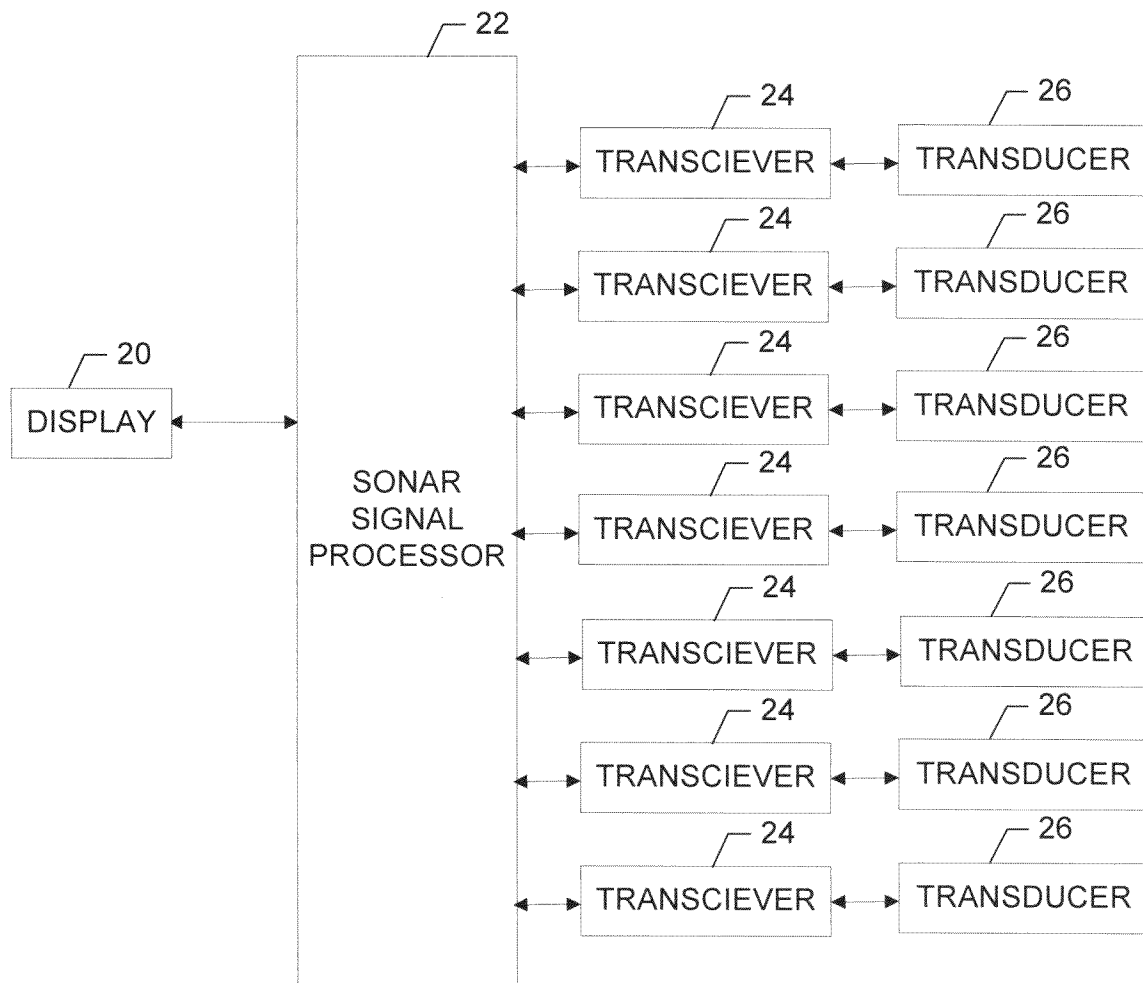
Doc Code: Artifact    Artifact Type Code: Z



**FIG. 1**  
**(PRIOR ART)**

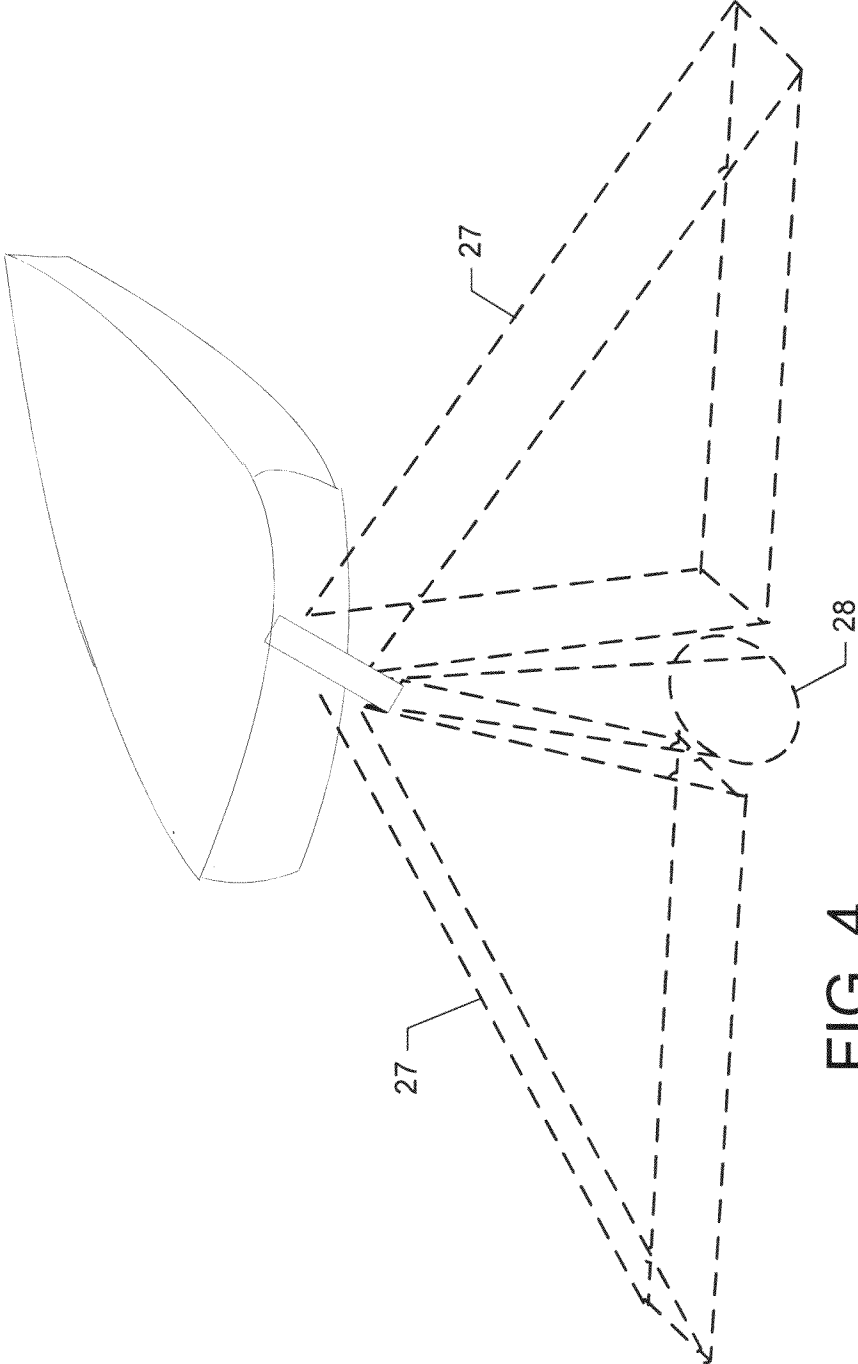


**FIG. 2**  
**(PRIOR ART)**



**FIG. 3.**  
**(Prior Art)**



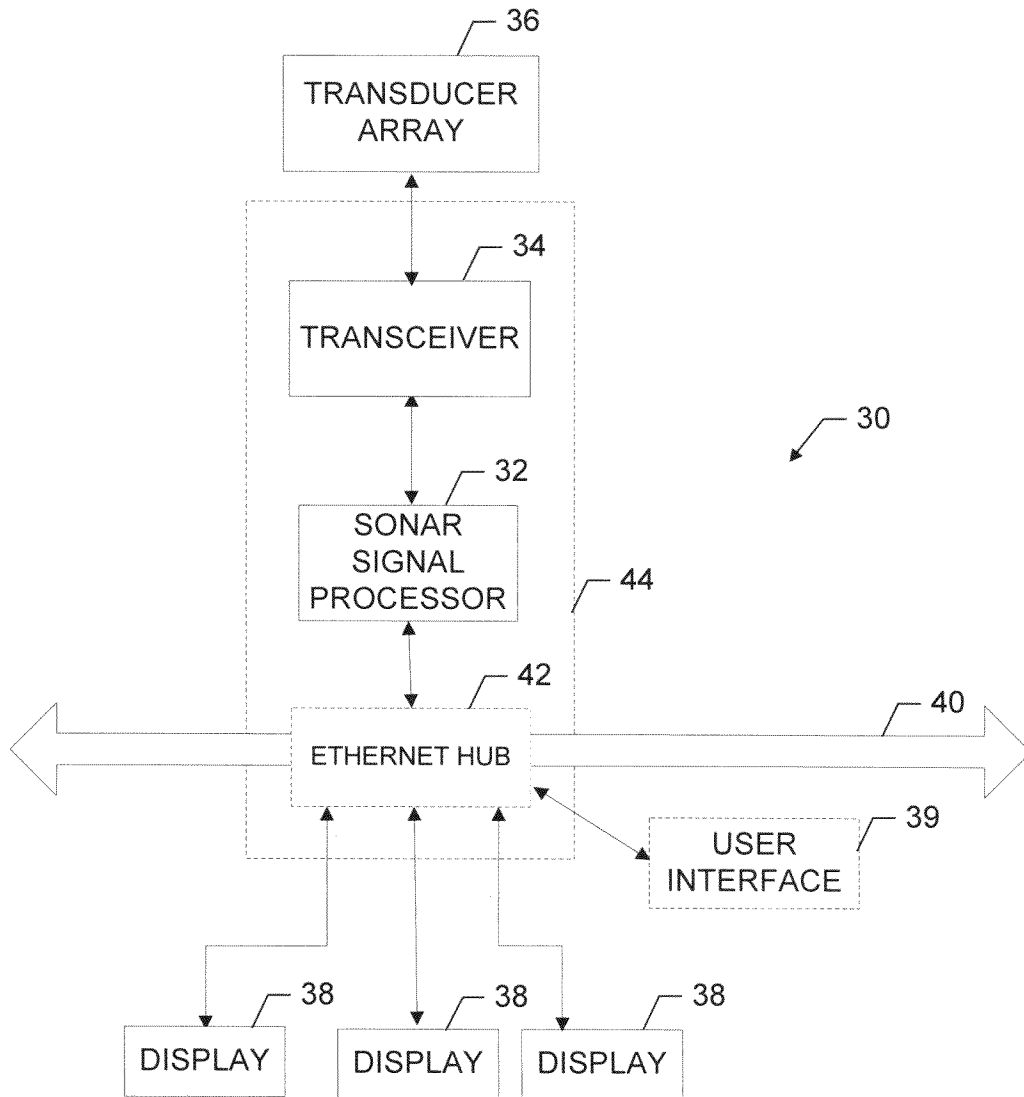


**FIG. 4.**  
**(Prior Art)**

Title: DOWNSCAN IMAGING SONAR

Inventor: Brian Maguire

AttyDktNo: 038495/369324

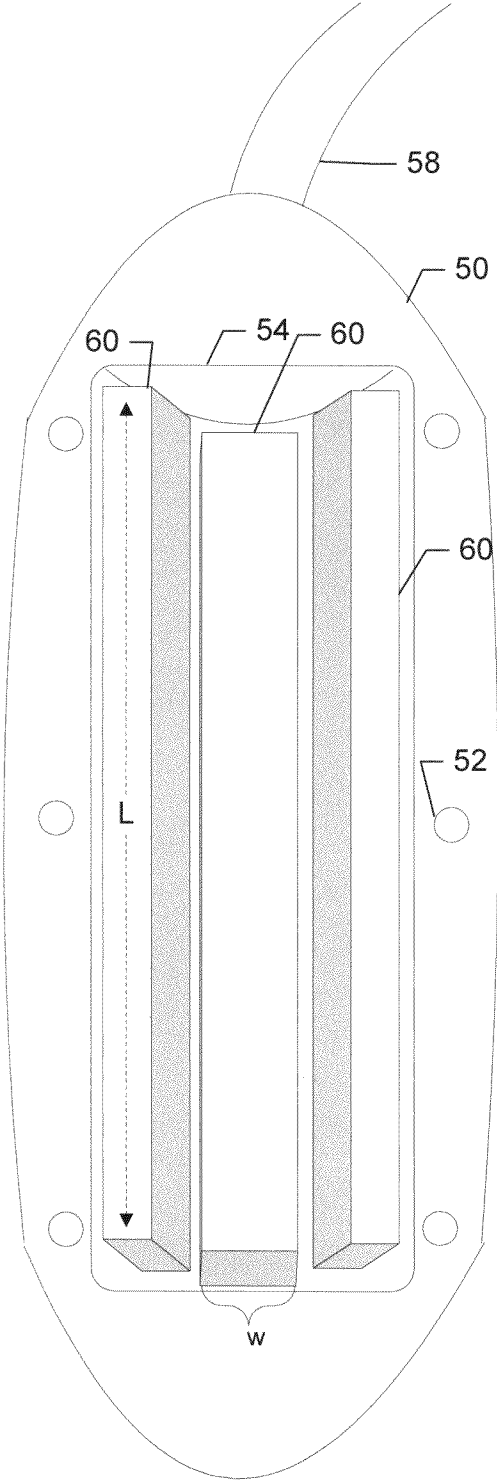


**FIG. 5.**

Title: DOWNSCAN IMAGING SONAR

Inventor: Brian Maguire

AttyDktNo: 038495/369324



**FIG. 6.**

SIDE VIEW:

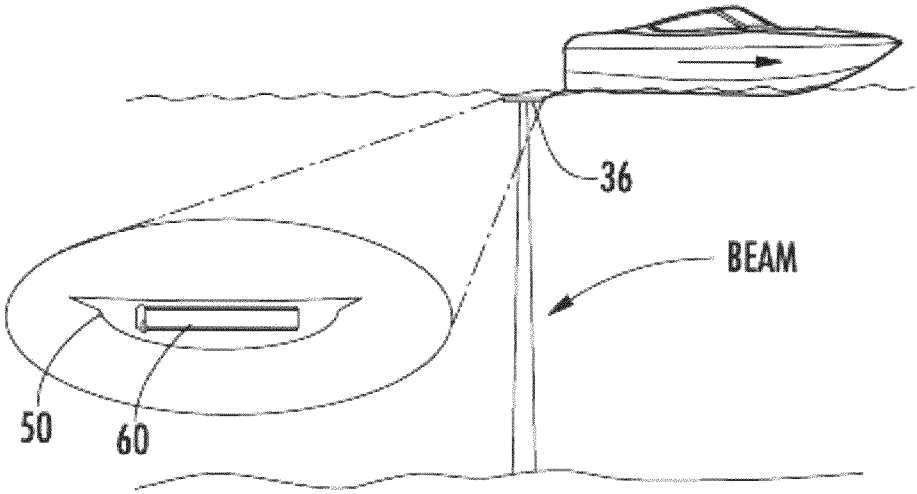


FIG. 7A

TOP VIEW:

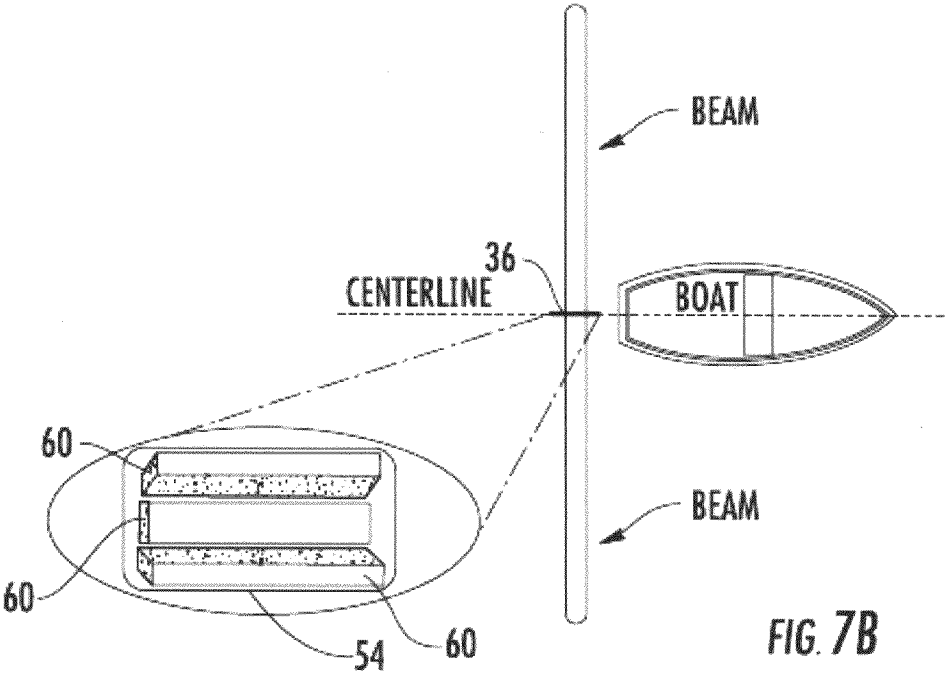
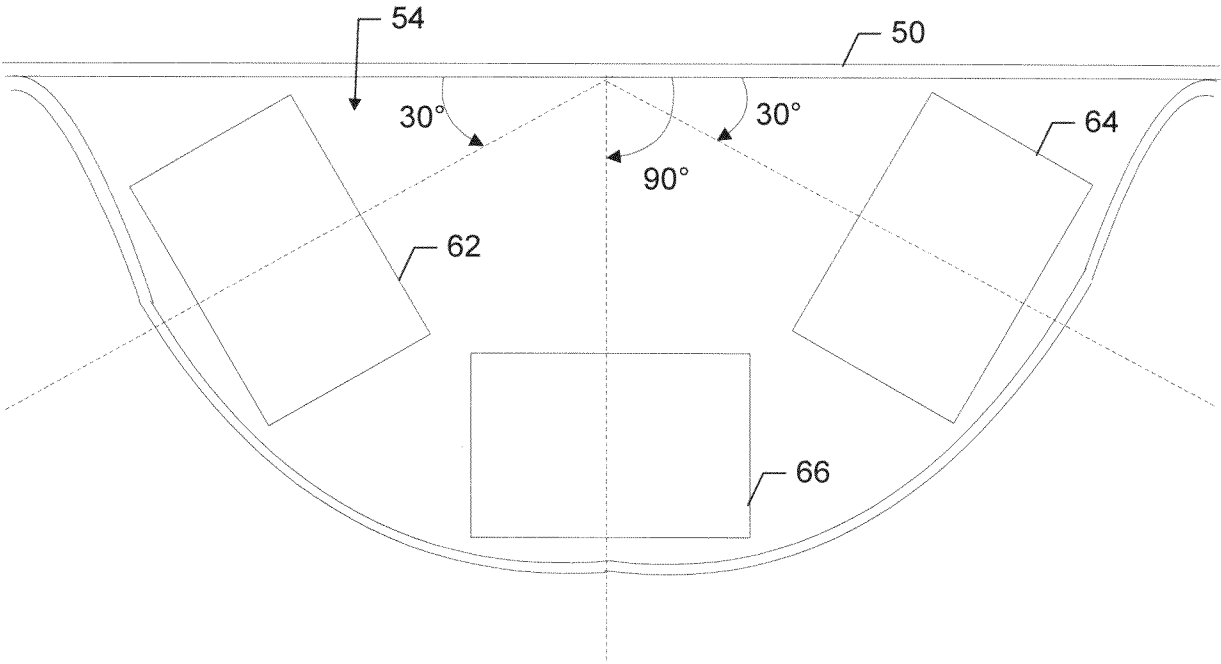


FIG. 7B



**FIG. 8A.**

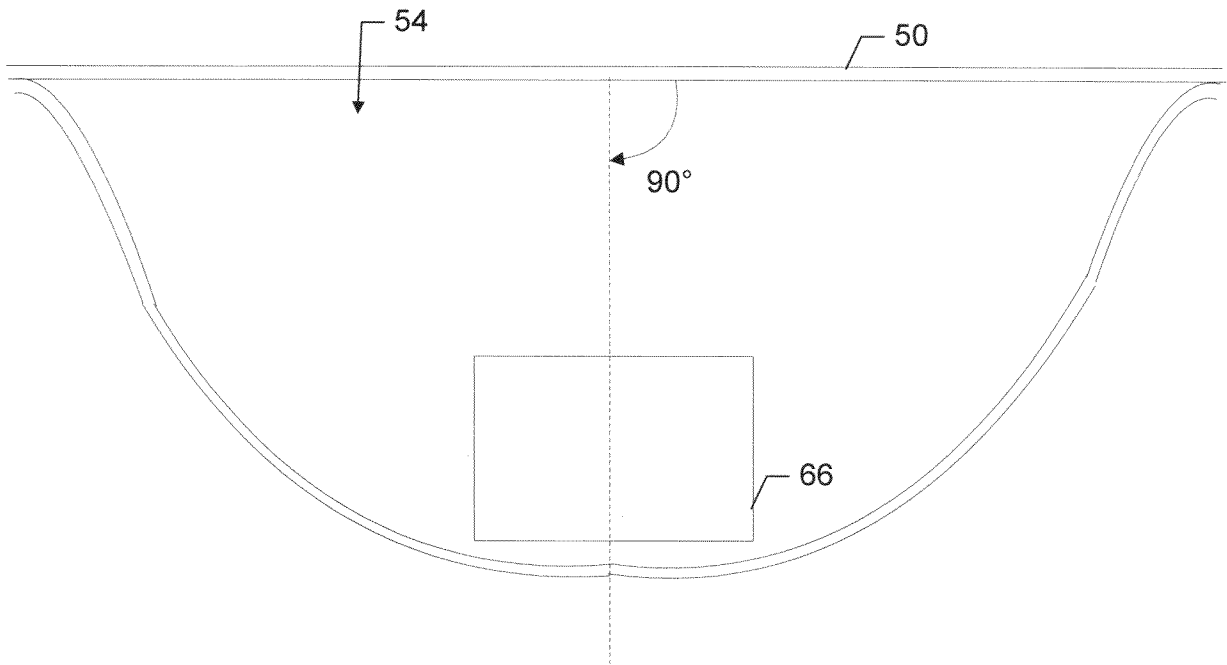


FIG. 8B.

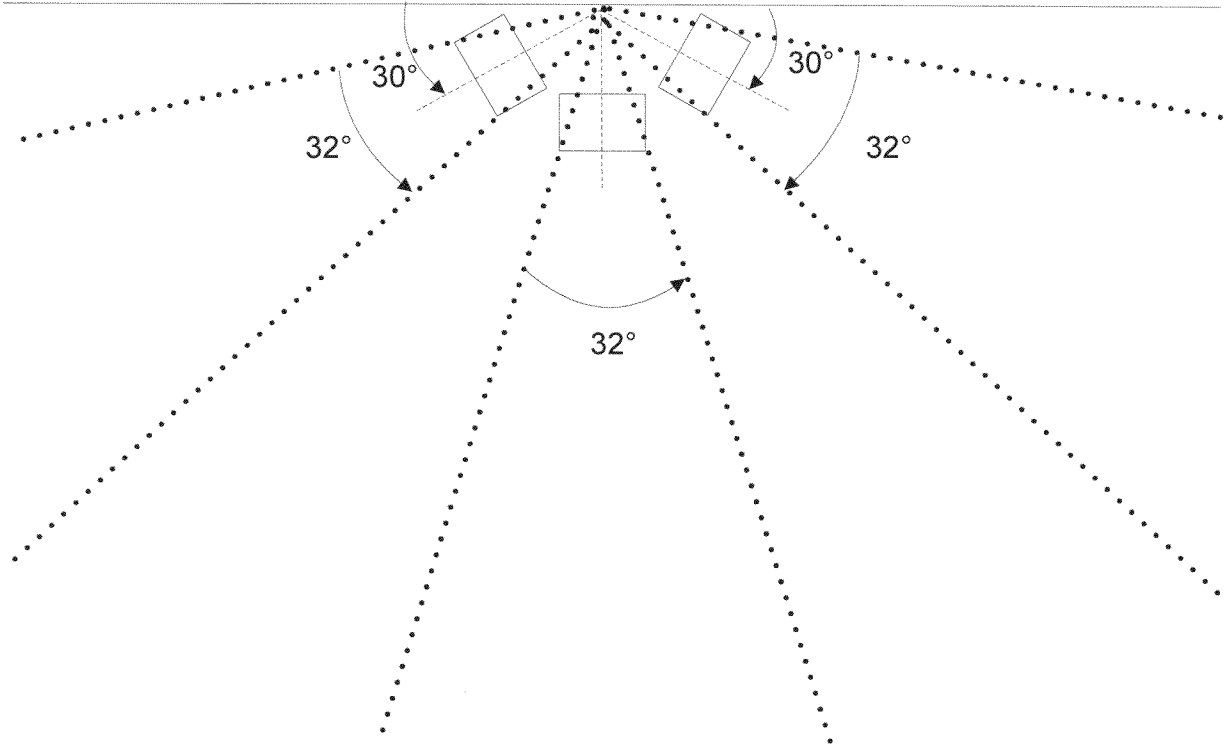


FIG. 9A.

Title: DOWNSCAN IMAGING SONAR

Inventor: Brian Maguire

AttyDktNo: 038495/369324

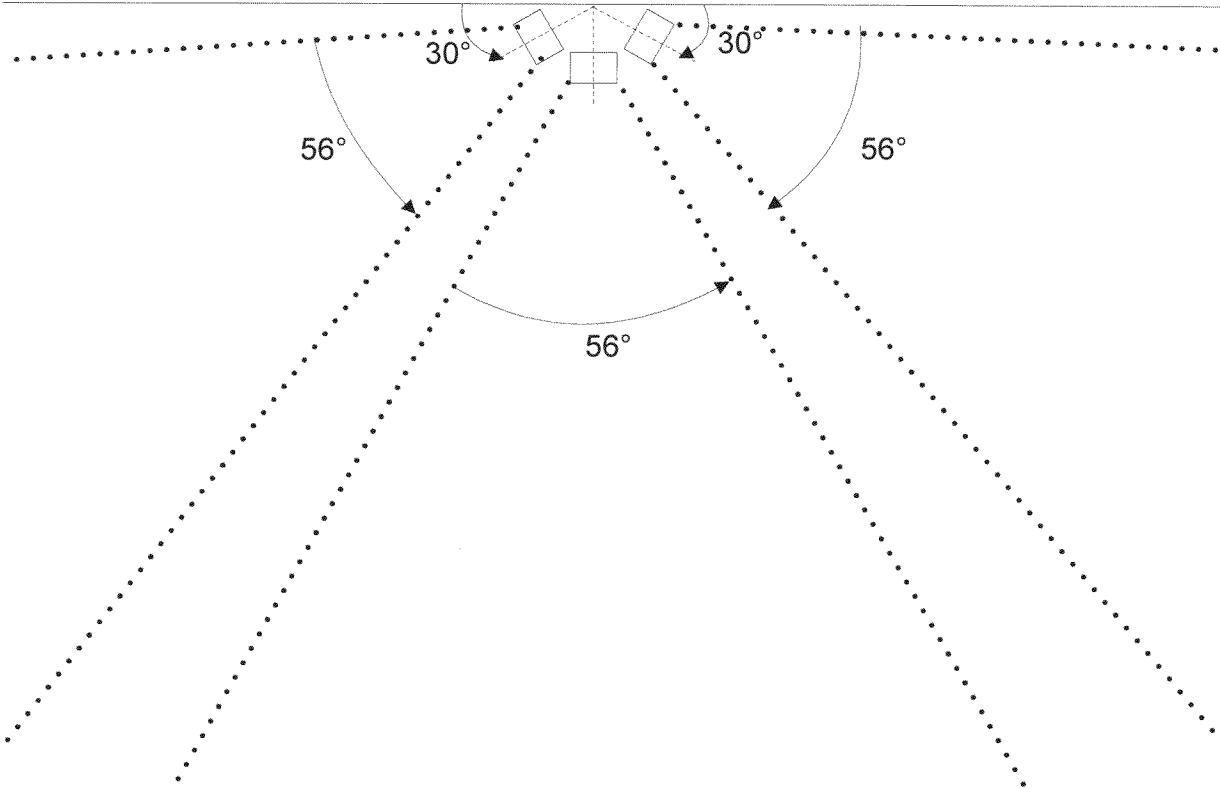


FIG. 9B.



Title: DOWNSCAN IMAGING SONAR  
Inventor: Brian Maguire  
AttyDktNo: 038495/369324



FIG. 10A.

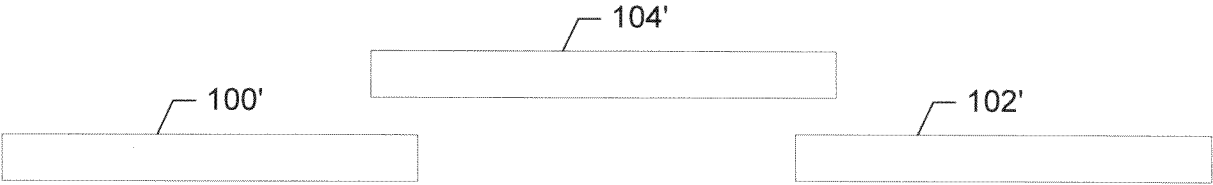
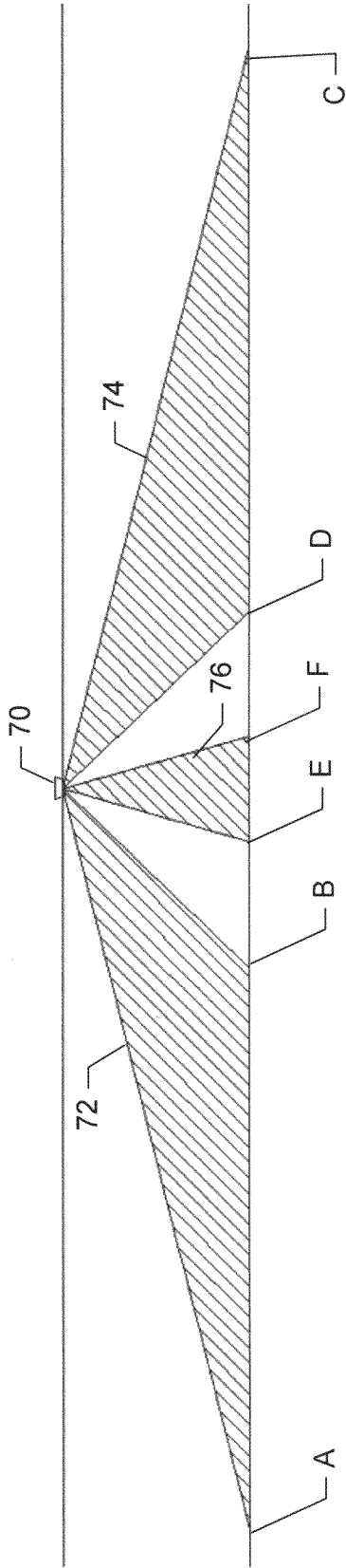


FIG. 10B.



**FIG. 11A.**

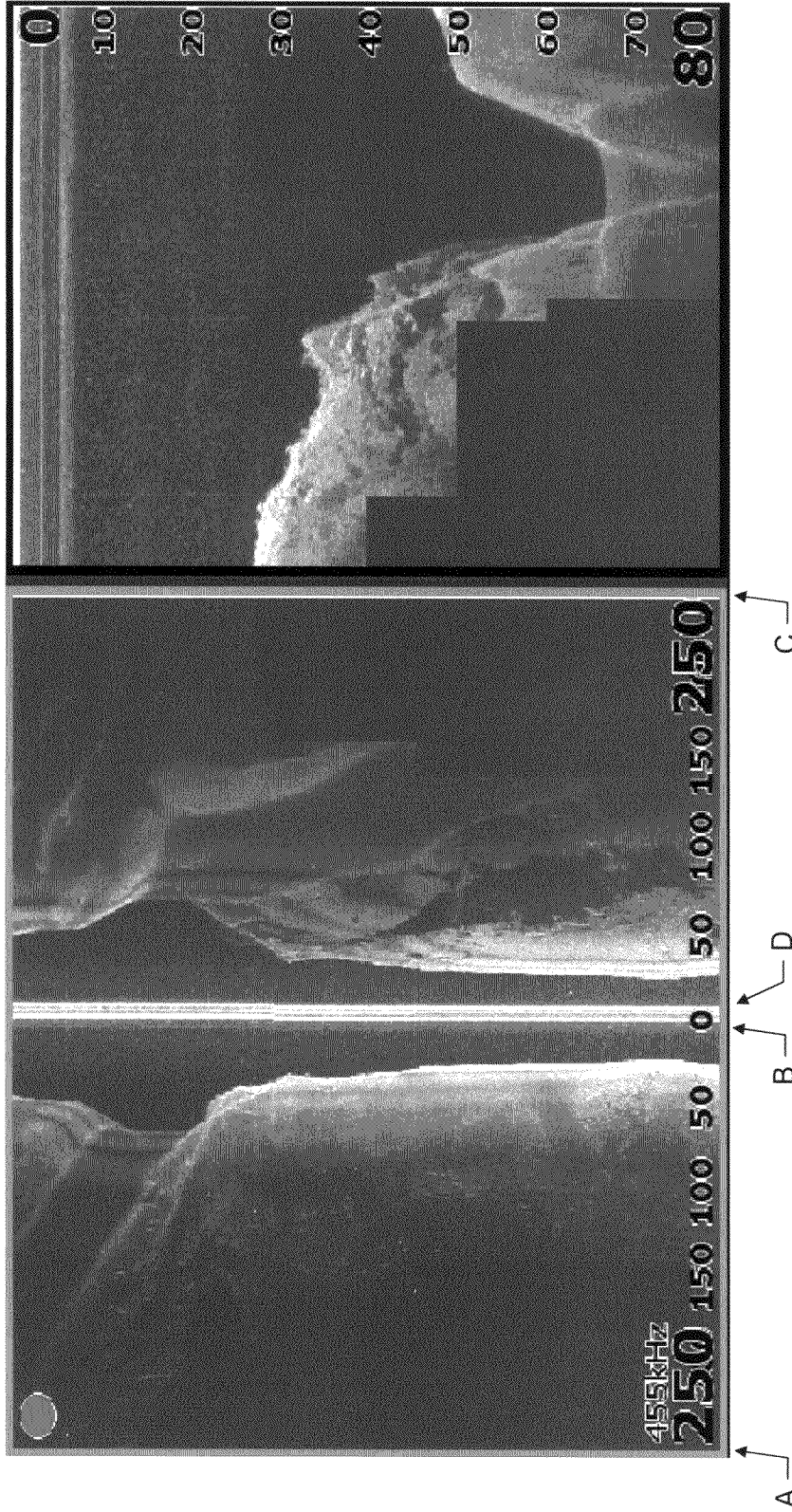


FIG. 11C.

FIG. 11B.

FIG. 12A.

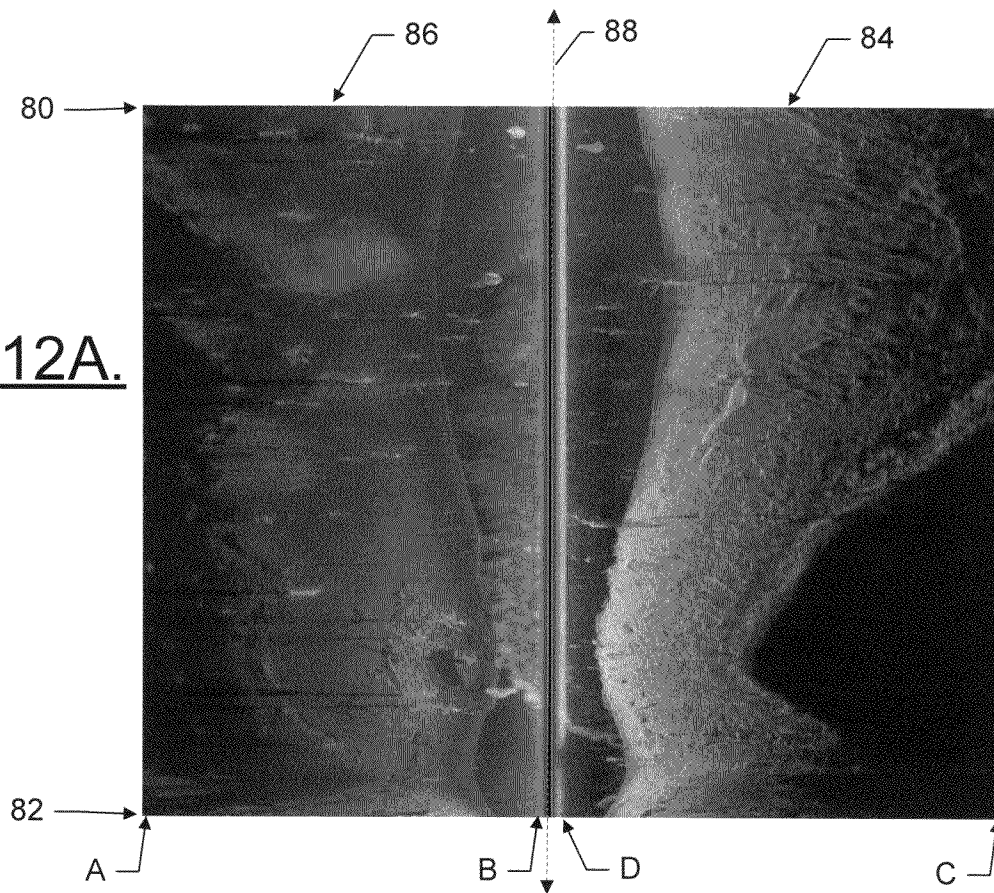
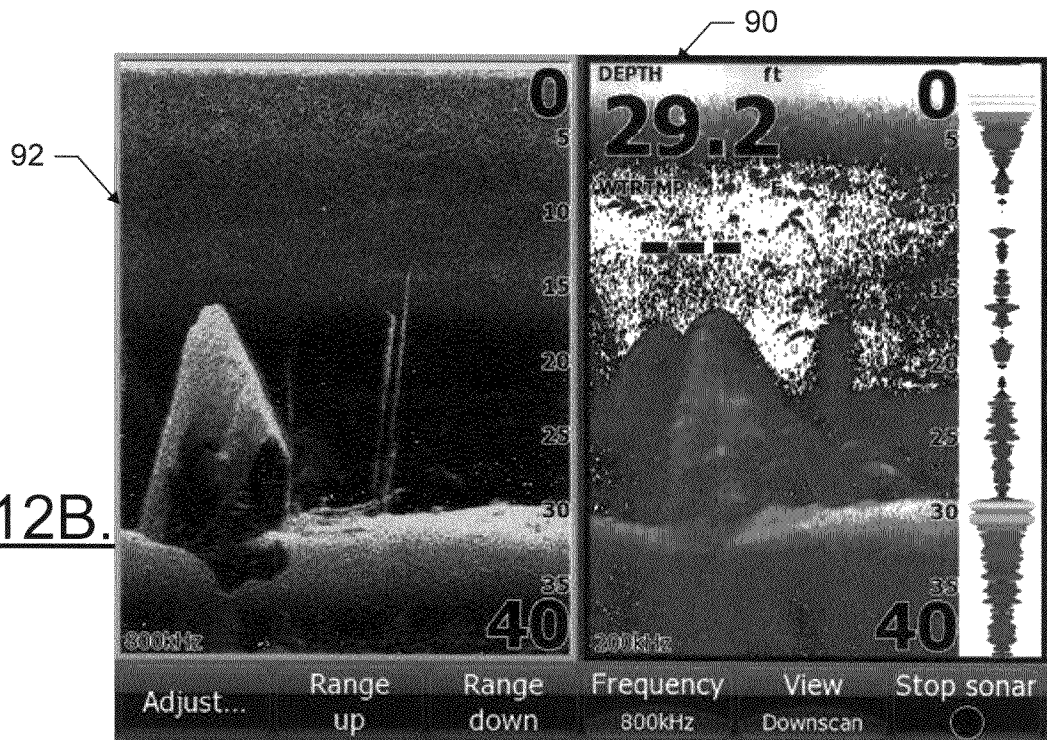


FIG. 12B.



Title: DOWNSCAN IMAGING SONAR

Inventor: Brian Maguire

AttyDktNo: 038495/369324

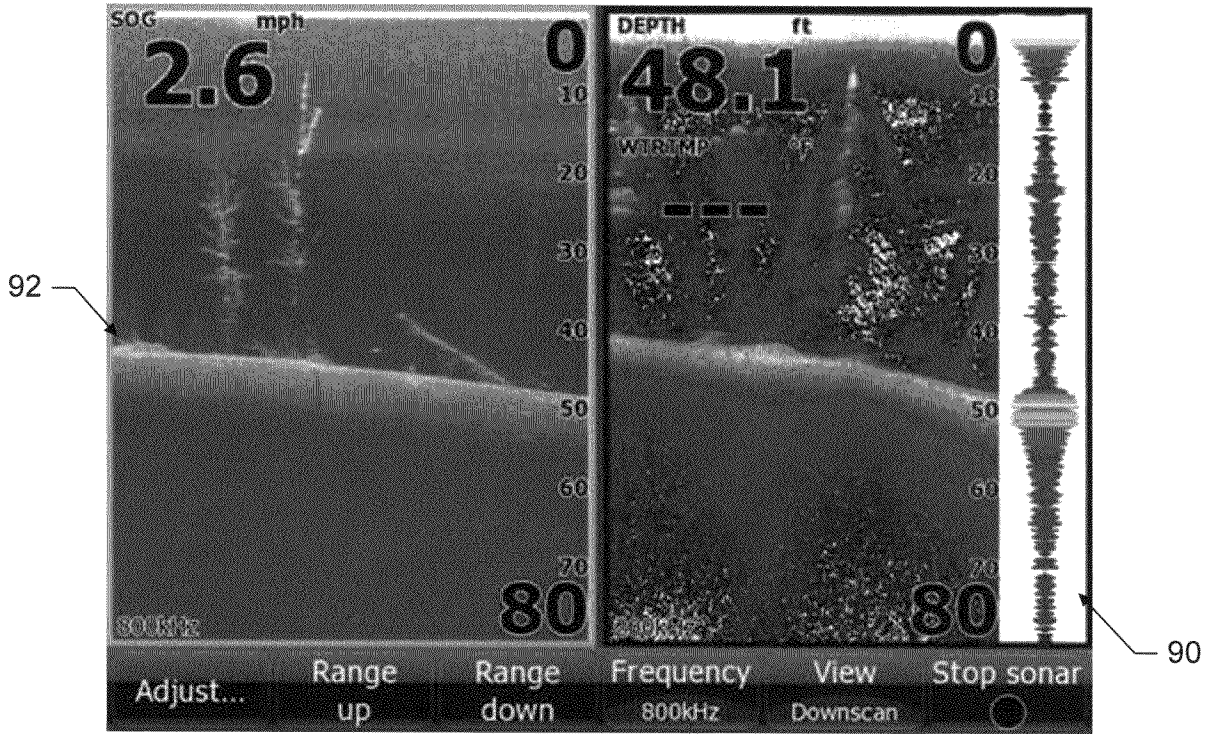


FIG. 12C.

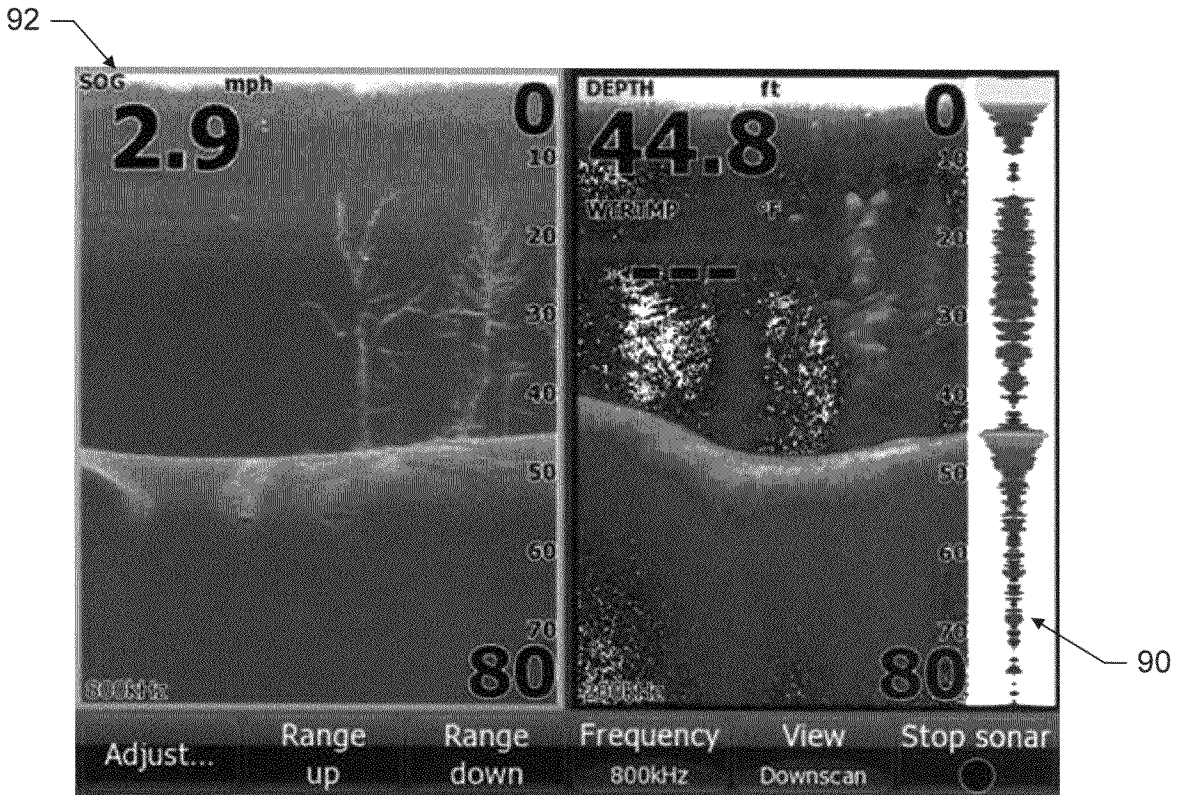


FIG. 12D.



Title: DOWNSCAN IMAGING SONAR

Inventor: Brian Maguire

AttyDktNo: 038495/369324

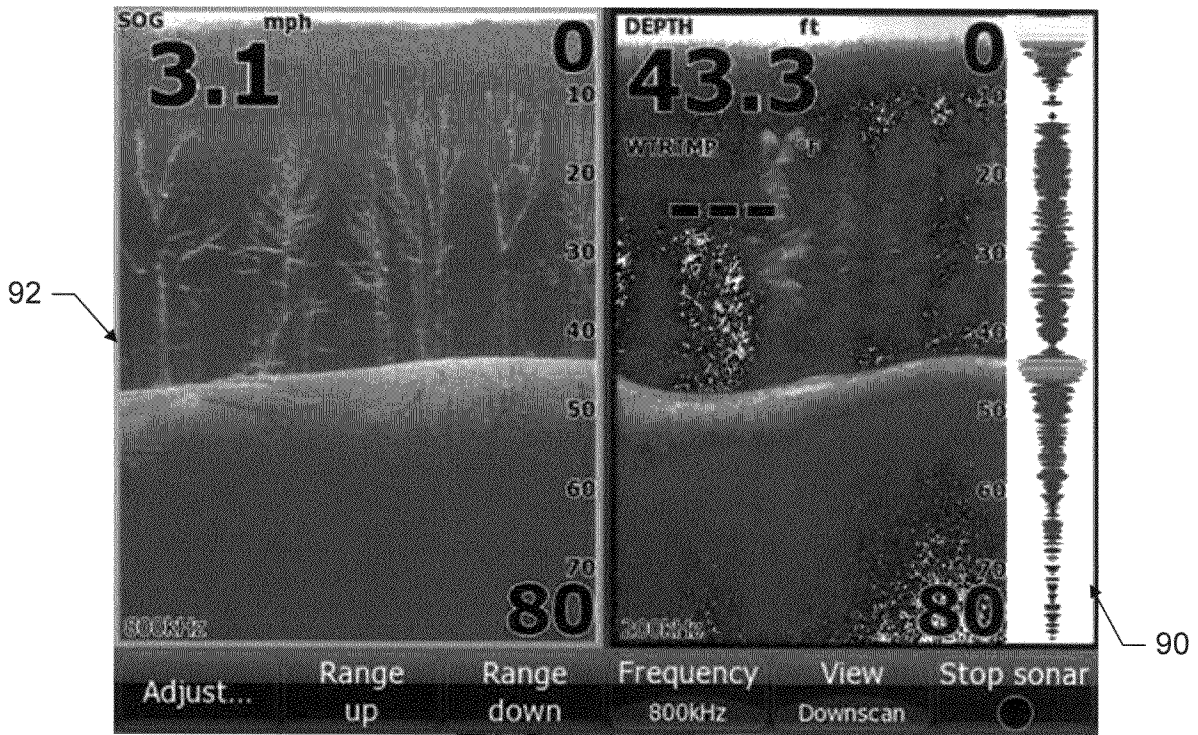


FIG. 12E.

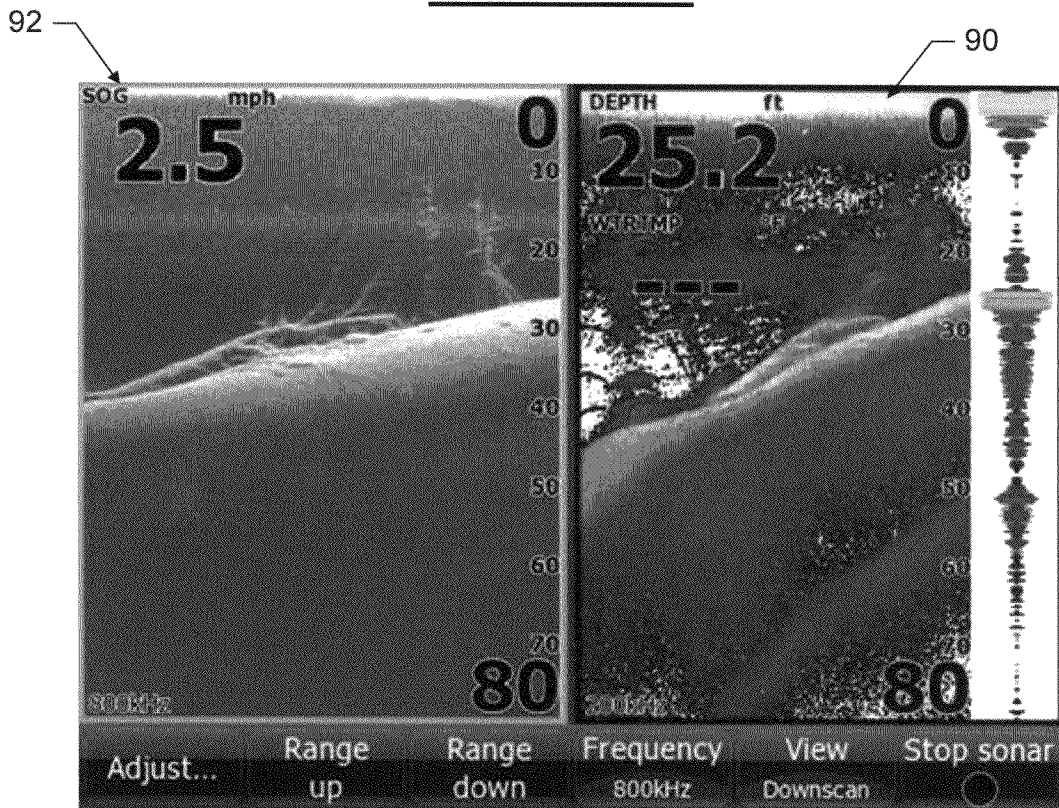


FIG. 12F.

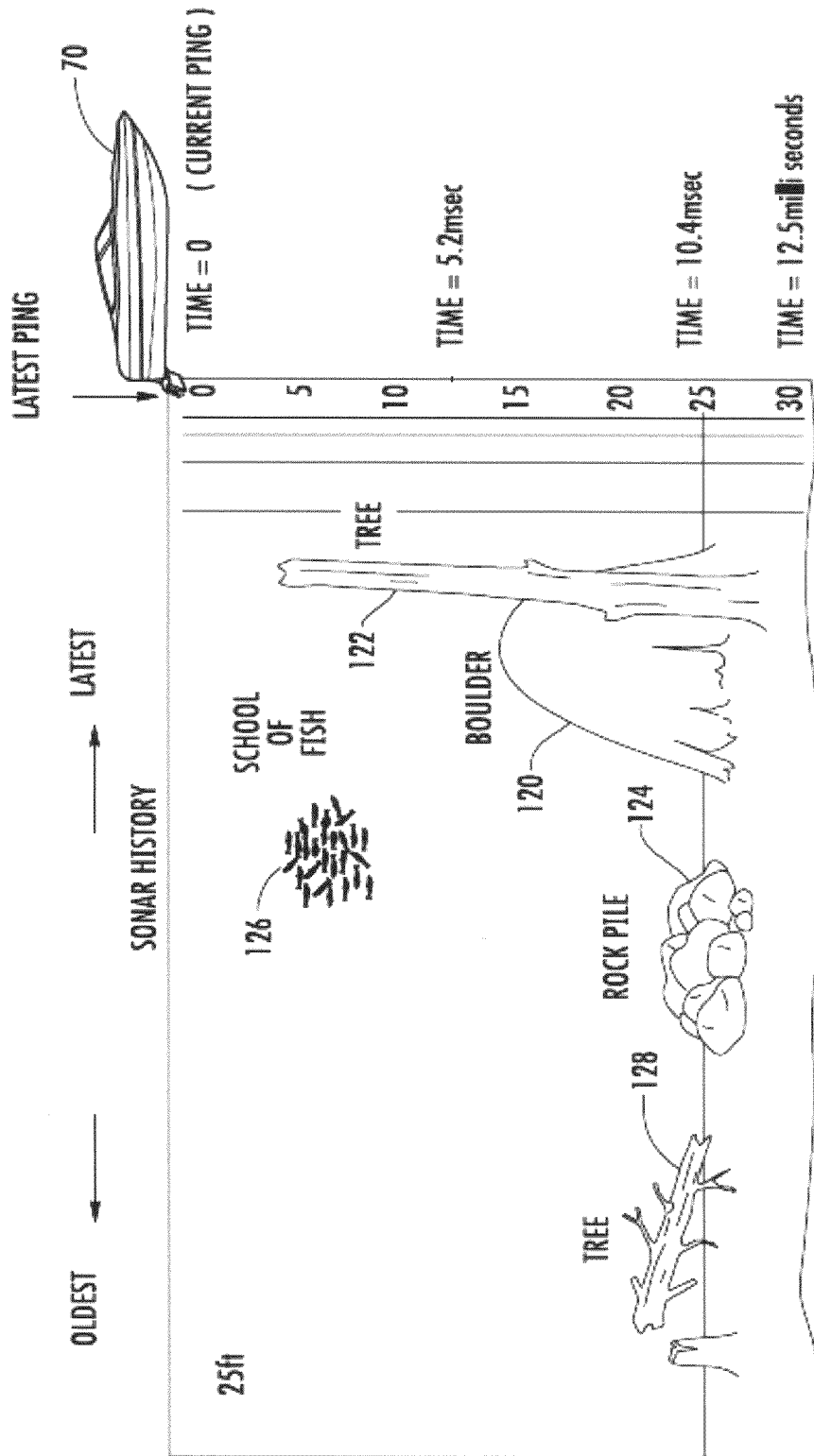


FIG. 13A

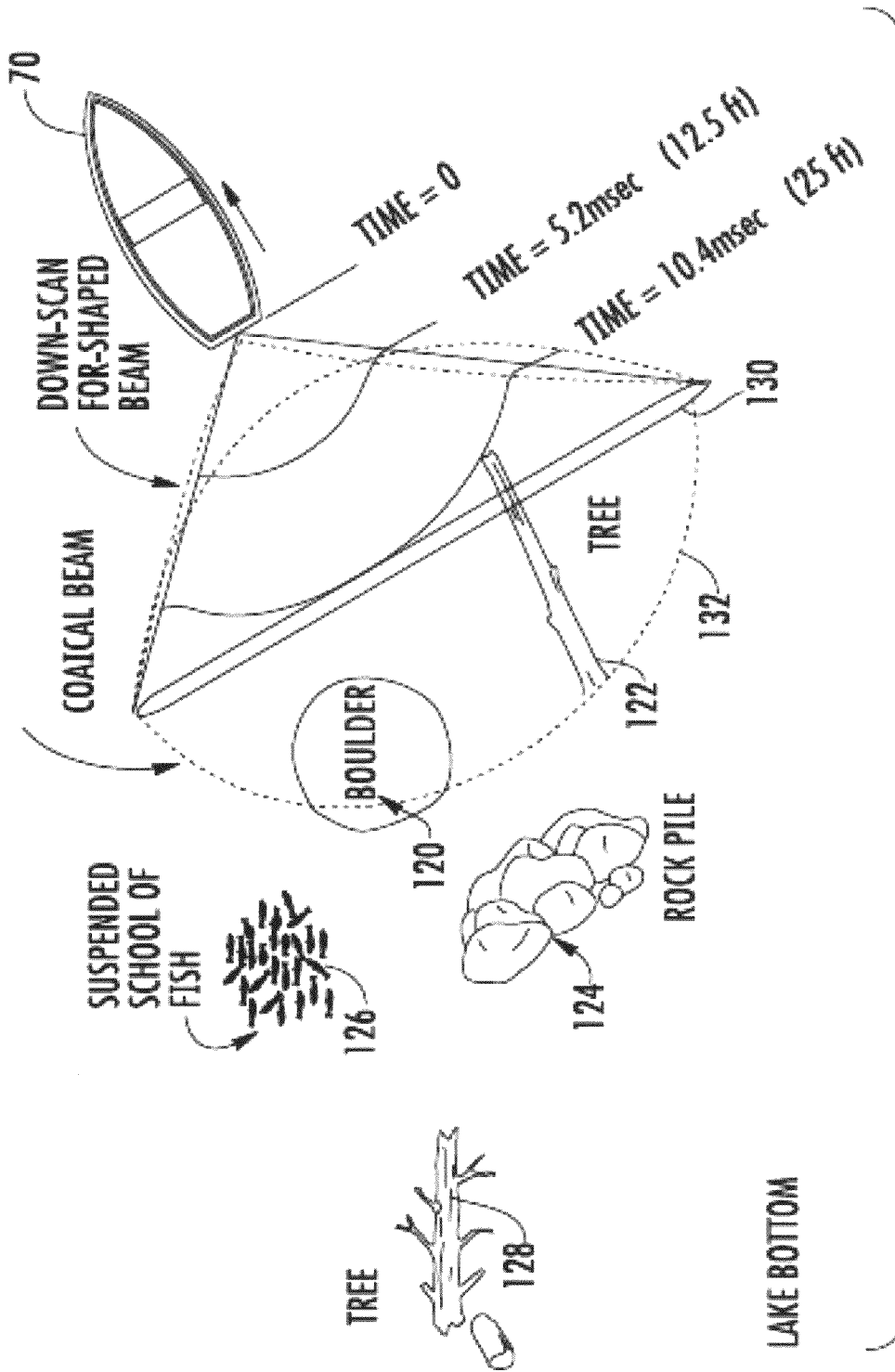
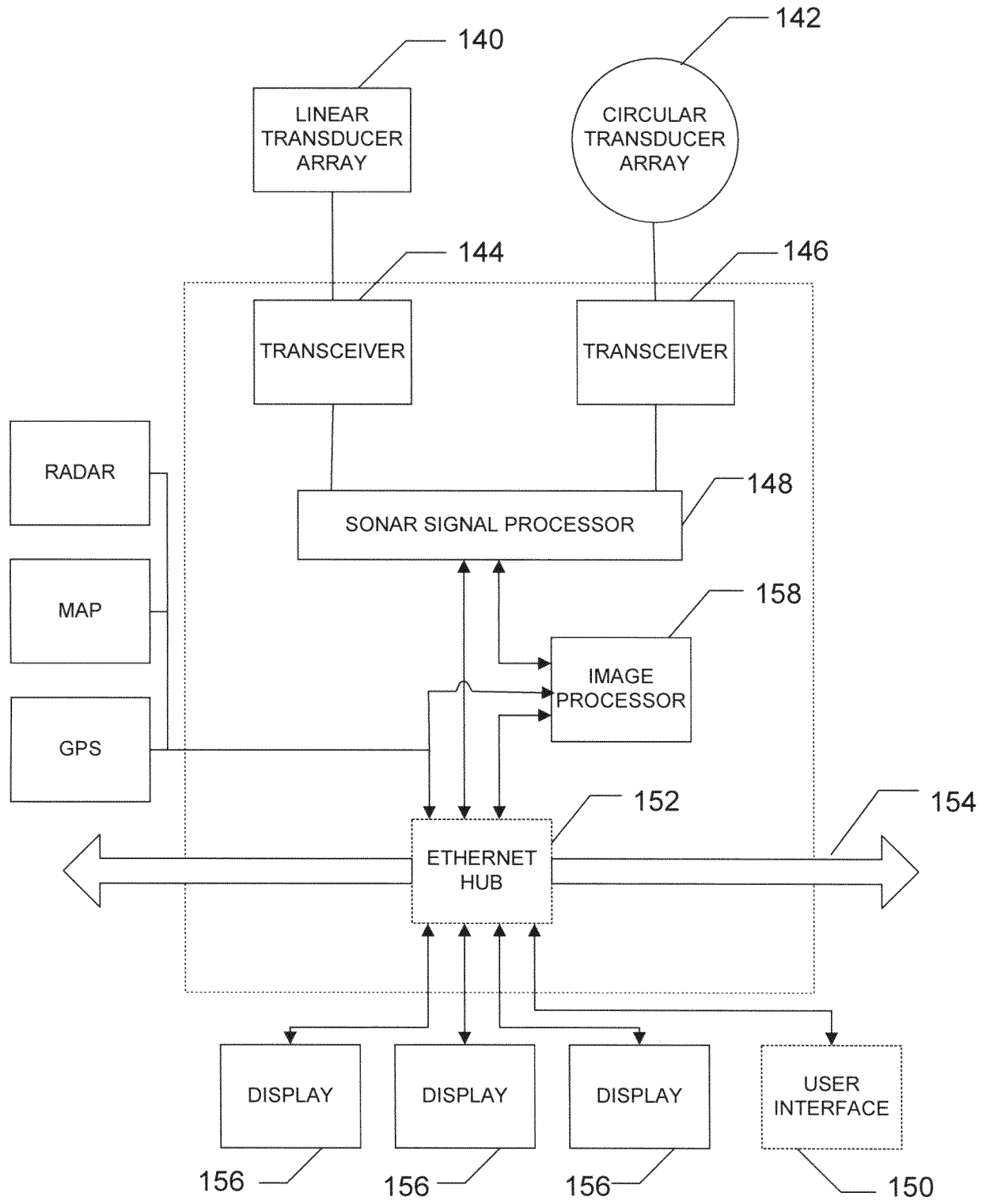


FIG. 13B



Title: DOWNSCAN IMAGING SONAR  
Inventor: Brian Maguire  
AttyDktNo: 038495/369324



**FIG. 14.**

Title: DOWNSCAN IMAGING SONAR

Inventor: Brian Maguire

AttyDktNo: 038495/369324

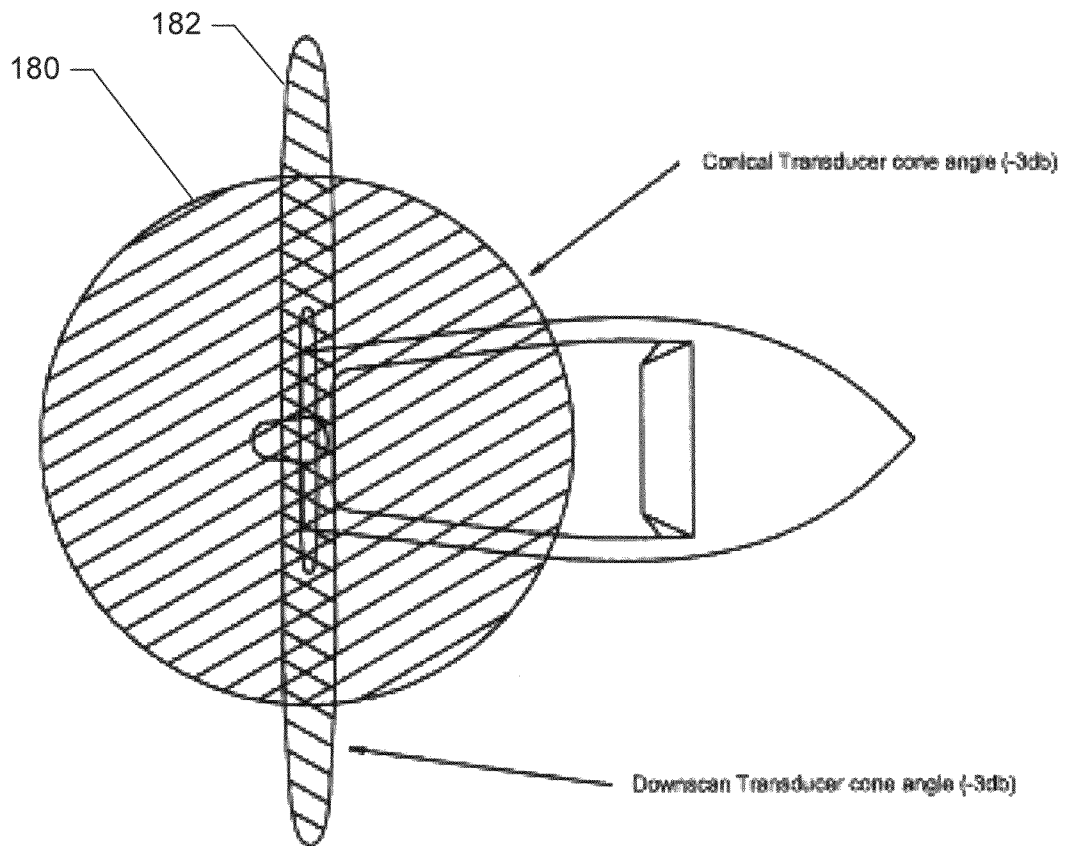
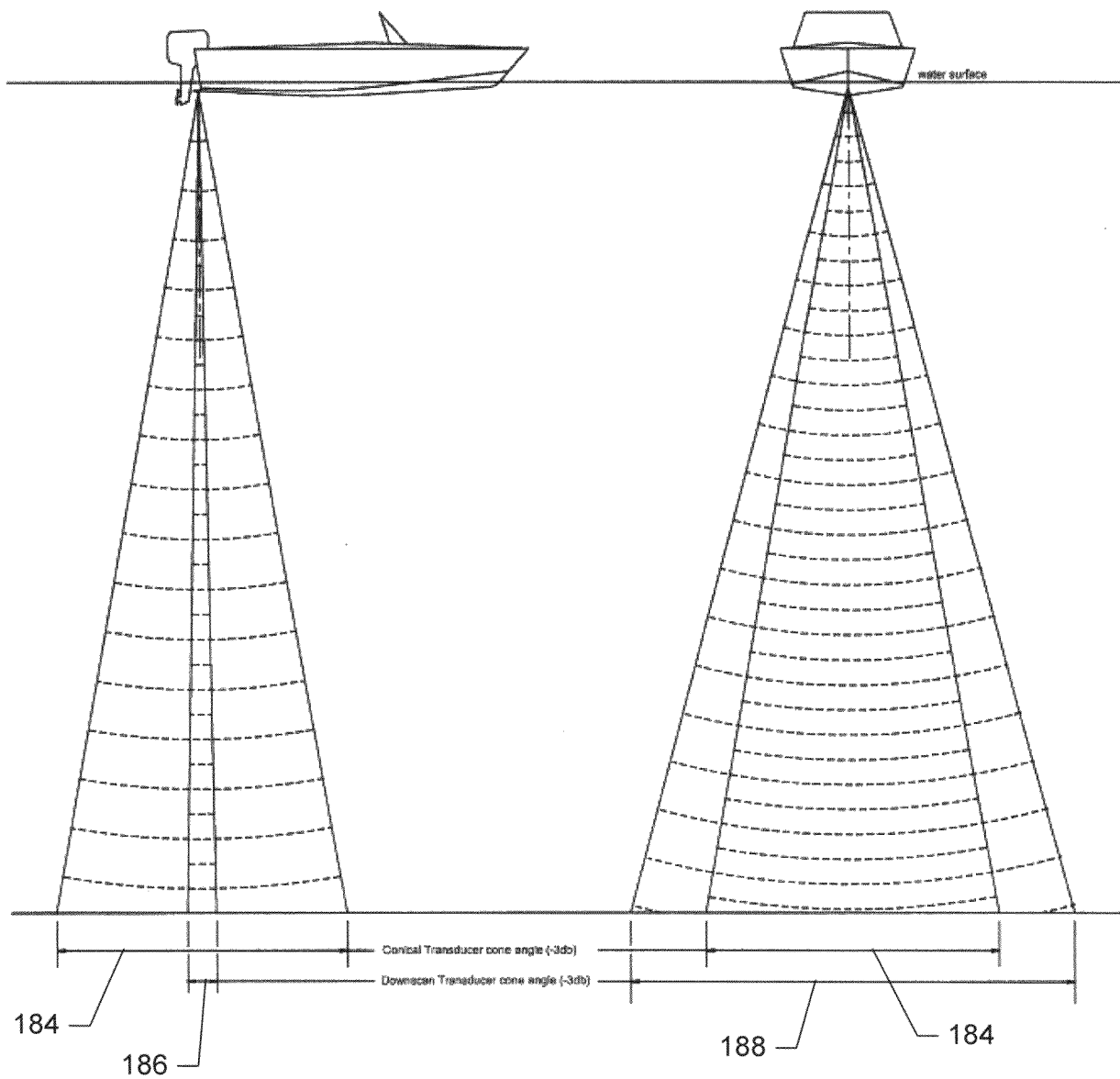


FIG. 15A.

Title: DOWNSCAN IMAGING SONAR

Inventor: Brian Maguire

AttyDktNo: 038495/369324



**FIG. 15B.**

FIG. 16A.

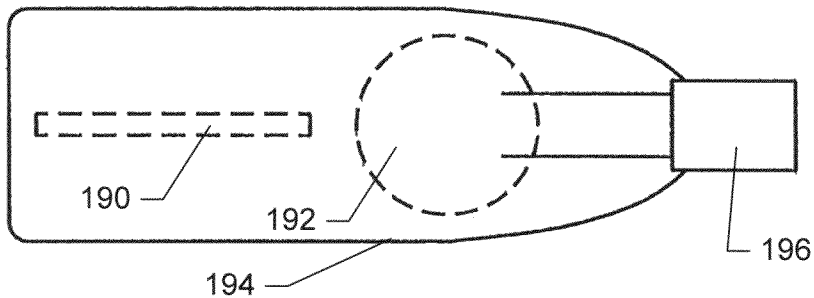


FIG. 16B.

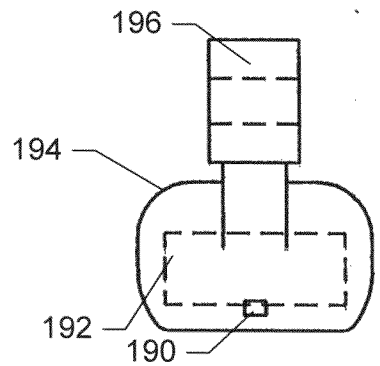
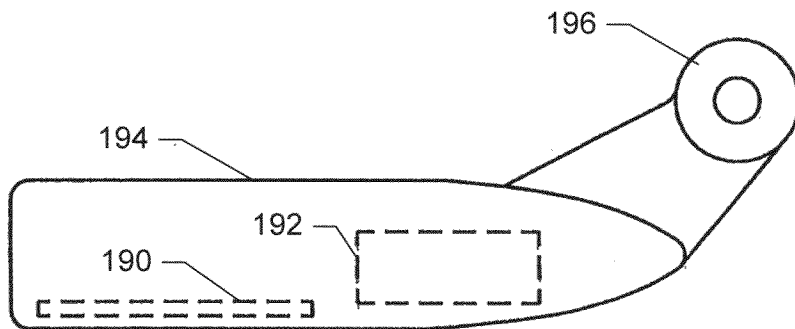


FIG. 16C.

FIG. 17A.

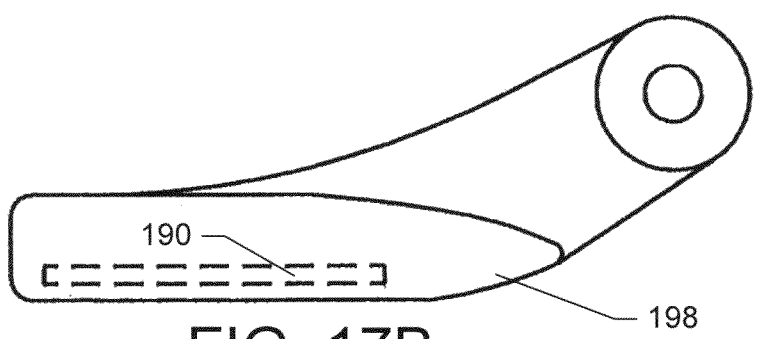
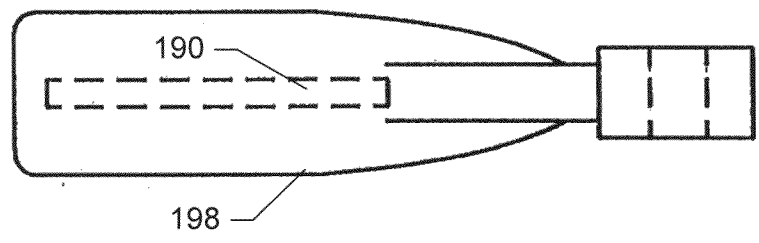


FIG. 17B.

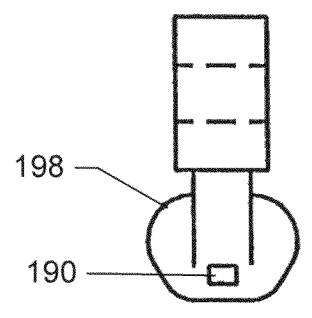


FIG. 17C.

PATENT APPLICATION SERIAL NO. \_\_\_\_\_

**U.S. DEPARTMENT OF COMMERCE  
PATENT AND TRADEMARK OFFICE  
FEE RECORD SHEET**

07/15/2009 HVUONG1 00000042 160605 12460139

01 FC:1011	330.00 DA
02 FC:1111	540.00 DA
03 FC:1311	220.00 DA
04 FC:1202	4108.00 DA
05 FC:1201	220.00 DA

PTO-1556  
(5/87)

Filing Date: 07/14/09

Approved for use through 7/31/2006. OMB 0651-0032  
U.S. Patent and Trademark Office; U.S. DEPARTMENT OF COMMERCE

Under the Paperwork Reduction Act of 1995, no persons are required to respond to a collection of information unless it displays a valid OMB control number.

PATENT APPLICATION FEE DETERMINATION RECORD Substitute for Form PTO-875					Application or Docket Number <b>12/460,139</b>					
<b>APPLICATION AS FILED – PART I</b>					<b>SMALL ENTITY</b>		<b>OR</b>		<b>OTHER THAN SMALL ENTITY</b>	
(Column 1)		(Column 2)			(Column 3)					
FOR	NUMBER FILED	NUMBER EXTRA			RATE (\$)	FEE (\$)			RATE (\$)	FEE (\$)
BASIC FEE (37 CFR 1.16(a), (b), or (c))	N/A	N/A			N/A	N/A			N/A	330
SEARCH FEE (37 CFR 1.16(k), (l), or (m))		N/A			N/A	N/A			N/A	540
EXAMINATION FEE (37 CFR 1.16(o), (p), or (q))	N/A	N/A			N/A	N/A			N/A	220
TOTAL CLAIMS (37 CFR 1.16(i))	99	minus 20	=	79	x\$26	N/A			x\$52	4108
INDEPENDENT CLAIMS (37 CFR 1.16(h))	4	minus 3	=	1	x\$110	N/A			x\$220	220
APPLICATION SIZE FEE (37 CFR 1.16(s))	If the specification and drawings exceed 100 sheets of paper, the application size fee due is \$270 (\$135 for small entity) for each additional 50 sheets or fraction thereof. See 35 U.S.C. 41(a)(1)(G) and 37 CFR									
MULTIPLE DEPENDENT CLAIM PRESENT (37 CFR 1.16(j))					195				390	
					TOTAL				TOTAL	5418
* If the difference in column 1 is less than zero, enter "0" in column 2.										
<b>APPLICATION AS AMENDED – PART II</b>					<b>SMALL ENTITY</b>		<b>OR</b>		<b>OTHER THAN SMALL ENTITY</b>	
(Column 1)		(Column 2)			(Column 3)					
AMENDMENT A	CLAIMS REMAINING AFTER AMENDMENT		HIGHEST NUMBER PREVIOUSLY PAID FOR	PRESENT EXTRA	RATE (\$)	ADDITIONAL FEE (\$)			RATE (\$)	ADDITIONAL FEE (\$)
	Total (37 CFR 1.16(i))	*	Minus **	=	X =	N/A			X =	N/A
	Independent (37 CFR 1.16(h))	*	Minus ***	=	X =	N/A			X =	N/A
	Application Size Fee (37 CFR 1.16(s))									
	FIRST PRESENTATION OF MULTIPLE DEPENDENT CLAIM (37 CFR 1.16(j))									
					TOTAL ADD'T FEE				TOTAL ADD'T FEE	
(Column 1)		(Column 2)			(Column 3)					
AMENDMENT B	CLAIMS REMAINING AFTER AMENDMENT		HIGHEST NUMBER PREVIOUSLY PAID FOR	PRESENT EXTRA	RATE (\$)	ADDITIONAL FEE (\$)			RATE (\$)	ADDITIONAL FEE (\$)
	Total (37 CFR 1.16(i))	*	Minus **	=	X =	N/A			X =	N/A
	Independent (37 CFR 1.16(h))	*	Minus ***	=	X =	N/A			X =	N/A
	Application Size Fee (37 CFR 1.16(s))									
	FIRST PRESENTATION OF MULTIPLE DEPENDENT CLAIM (37 CFR 1.16(j))									
					TOTAL ADD'T FEE				TOTAL ADD'T FEE	
* If the entry in column 1 is less than the entry in column 2, write "0" in column 3.										
** If the "Highest Number Previously Paid For" IN THIS SPACE is less than 20, enter "20".										
*** If the "Highest Number Previously Paid For" IN THIS SPACE is less than 3, enter "3".										
The "Highest Number Previously Paid For" (Total or Independent) is the highest number found in the appropriate box in column 1.										

This collection of information is required by 37 CFR 1.16. The information is required to obtain or retain a benefit by the public which is to file (and by the USPTO to process) an application. Confidentiality is governed by 35 U.S.C. 122 and 37 CFR 1.14. This collection is estimated to take 12 minutes to complete, including gathering, preparing, and submitting the completed application form to the USPTO. Time will vary depending upon the individual case. Any comments on the amount of time you require to complete this form and/or suggestions for reducing this burden, should be sent to the Chief Information Officer, U.S. Patent and Trademark Office, U.S. Department of Commerce, P.O. Box 1450, Alexandria, VA 22313-1450. DO NOT SEND FEES OR COMPLETED FORMS TO THIS ADDRESS. SEND TO: Commissioner for Patents, P.O. Box 1450, Alexandria, VA 22313-1450.