

AO 120 (Rev. 08/10)

TO: <b>Mail Stop 8</b> <b>Director of the U.S. Patent and Trademark Office</b> P.O. Box 1450 Alexandria, VA 22313-1450	<b>REPORT ON THE                  FILING OR DETERMINATION OF AN                  ACTION REGARDING A PATENT OR                  TRADEMARK</b>
---	--

In Compliance with 35 U.S.C. § 290 and/or 15 U.S.C. § 1116 you are hereby advised that a court action has been filed in the U.S. District Court for the District of Delaware on the following

Trademarks or  Patents. (  the patent action involves 35 U.S.C. § 292.)

DOCKET NO.	DATE FILED 11/15/2012	U.S. DISTRICT COURT for the District of Delaware
PLAINTIFF PHISON ELECTRONICS CORP.		DEFENDANT PNY TECHNOLOGIES INC.
PATENT OR TRADEMARK NO.	DATE OF PATENT OR TRADEMARK	HOLDER OF PATENT OR TRADEMARK
1 US 7,518,879	4/14/2009	Phison Electronics Corp.
2 US 8,176,267	5/8/2012	Phison Electronics Corp.
3		
4		
5		

In the above—entitled case, the following patent(s)/ trademark(s) have been included:

DATE INCLUDED	INCLUDED BY <input type="checkbox"/> Amendment <input type="checkbox"/> Answer <input type="checkbox"/> Cross Bill <input type="checkbox"/> Other Pleading		
PATENT OR TRADEMARK NO.	DATE OF PATENT OR TRADEMARK	HOLDER OF PATENT OR TRADEMARK	
1			
2			
3			
4			
5			

In the above—entitled case, the following decision has been rendered or judgement issued:

DECISION/JUDGEMENT
--------------------

CLERK	(BY) DEPUTY CLERK	DATE
-------	-------------------	------

Copy 1—Upon initiation of action, mail this copy to Director Copy 3—Upon termination of action, mail this copy to Director  
 Copy 2—Upon filing document adding patent(s), mail this copy to Director Copy 4—Case file copy



RECEIVED TO ACCOUNTING

2009 JUL 30 PM 4: 10

IFW

IN THE UNITED STATES PATENT & TRADEMARK OFFICE

Patent

In re Application of:

Confirmation No.: 8664

Inventor: Tom CHUNG et al.

Examiner: Y. Semenenko

RECEIVED

Patent No: 7,518,879 B2

Art Unit: 2841

AUG 05 2009

Issued: April 14, 2009

Docket: CHUN3098/BEU

OFFICE OF PETITIONS

For: Universal Serial BUS (USB) Memory Plug

CHANGE IN ENTITY STATUS AND SUBMISSION OF ADDITIONAL APPLICATION FEE

Honorable Commissioner for Patents Washington, D.C. 20231

Sir:

The above identified patent was filed on March 21, 2006 under Serial No. 11/384,371 and was granted on April 14, 2009 under number 7,518,879 under the erroneous assumption that the application qualified for fees under Small Entity Status by the firm of the undersigned. The Taiwan Agent representing the applicant just advised the undersigned of this error and requested that the Entity Status of this application be immediately changed from Small to LARGE.

Since this error was unintentional and clerical in nature, it is respectfully requested that the Entity Status of this application be henceforth designated under LARGE ENTITY STATUS and it is requested that the fee of \$1,375.00 be charged to Deposit Account No. 02-0200 to cover the additional filing fee of \$590.00 and grant fee of \$755.00 associated with the new application Large Entity Status fee.

If there should be any questions in connection with this matter, the undersigned may be reached at his Alexandria, Virginia office at (703) 683-0500.

Respectfully submitted, BACON & THOMAS, PLLC

Handwritten signature of Chung Chin Chen

Chung Chin Chen 07/31/2009 DALLEN 00000027 020200 11384371 Registration No. 31,725 01, FC:1461 1375.00 DA

BACON & THOMAS 625 Slaters Lane - 4th Floor Alexandria, VA 22314 (703) 683-0500 Dated: July 29, 2009



UNITED STATES PATENT AND TRADEMARK OFFICE

UNITED STATES DEPARTMENT OF COMMERCE
United States Patent and Trademark Office
Address: COMMISSIONER FOR PATENTS
P.O. Box 1450
Alexandria, Virginia 22313-1450
www.uspto.gov

Table with 5 columns: APPLICATION NO., ISSUE DATE, PATENT NO., ATTORNEY DOCKET NO., CONFIRMATION NO.
Row 1: 11/384,371, 04/14/2009, 7518879, CHUN3098/EM, 8664

23364 7590 03/25/2009
BACON & THOMAS, PLLC
625 SLATERS LANE
FOURTH FLOOR
ALEXANDRIA, VA 22314-1176

ISSUE NOTIFICATION

The projected patent number and issue date are specified above.

Determination of Patent Term Adjustment under 35 U.S.C. 154 (b)
(application filed on or after May 29, 2000)

The Patent Term Adjustment is 361 day(s). Any patent to issue from the above-identified application will include an indication of the adjustment on the front page.

If a Continued Prosecution Application (CPA) was filed in the above-identified application, the filing date that determines Patent Term Adjustment is the filing date of the most recent CPA.

Applicant will be able to obtain more detailed information by accessing the Patent Application Information Retrieval (PAIR) WEB site (http://pair.uspto.gov).

Any questions regarding the Patent Term Extension or Adjustment determination should be directed to the Office of Patent Legal Administration at (571)-272-7702. Questions relating to issue and publication fee payments should be directed to the Customer Service Center of the Office of Patent Publication at (571)-272-4200.

APPLICANT(s) (Please see PAIR WEB site http://pair.uspto.gov for additional applicants):

Tom Chung, Hsinchu, TAIWAN;
Dean Huang, Hsinchu, TAIWAN;
Peter Huang, Hsinchu, TAIWAN;



UNITED STATES PATENT AND TRADEMARK OFFICE

UNITED STATES DEPARTMENT OF COMMERCE  
 United States Patent and Trademark Office  
 Address: COMMISSIONER FOR PATENTS  
 P.O. Box 1450  
 Alexandria, Virginia 22313-1450  
 www.uspto.gov

BIB DATA SHEET

CONFIRMATION NO. 8664

<b>SERIAL NUMBER</b> 11/384,371	<b>FILING or 371(c) DATE</b> 03/21/2006 <b>RULE</b>	<b>CLASS</b> 361 235	<b>GROUP ART UNIT</b> 2841	<b>ATTORNEY DOCKET NO.</b> CHUN3098/EM		
<b>APPLICANTS</b> Tom Chung, Hsinchu, TAIWAN; Dean Huang, Hsinchu, TAIWAN; Peter Huang, Hsinchu, TAIWAN;						
** CONTINUING DATA *****						
** FOREIGN APPLICATIONS *****						
** IF REQUIRED, FOREIGN FILING LICENSE GRANTED ** * SMALL ENTITY ** 04/13/2006						
Foreign Priority claimed <input type="checkbox"/> Yes <input checked="" type="checkbox"/> No	35 USC 119(a-d) conditions met <input type="checkbox"/> Yes <input checked="" type="checkbox"/> No	<input type="checkbox"/> Met after Allowance	<b>STATE OR COUNTRY</b> TAIWAN	<b>SHEETS DRAWINGS</b> 5	<b>TOTAL CLAIMS</b> 21 18	<b>INDEPENDENT CLAIMS</b> 3
Verified and /YURIY SEMENENKO/ Examiner's Signature	Initials					
<b>ADDRESS</b> BACON & THOMAS, PLLC 625 SLATERS LANE FOURTH FLOOR ALEXANDRIA, VA 22314-1176 UNITED STATES						
<b>TITLE</b> UNIVERSAL SERIAL BUS (USB) MEMORY PLUG						
<b>FILING FEE RECEIVED</b> 825	FEES: Authority has been given in Paper No. _____ to charge/credit DEPOSIT ACCOUNT No. _____ for following:		<input type="checkbox"/> All Fees <input type="checkbox"/> 1.16 Fees (Filing) <input type="checkbox"/> 1.17 Fees (Processing Ext. of time) <input type="checkbox"/> 1.18 Fees (Issue) <input type="checkbox"/> Other _____ <input type="checkbox"/> Credit			

PART B - FEE(S) TRANSMITTAL

Complete and send this form, together with applicable fee(s), to: **Mail** Mail Stop ISSUE FEE  
**Commissioner for Patents**  
**P.O. Box 1450**  
**Alexandria, Virginia 22313-1450**  
**or Fax (571)-273-2885**

INSTRUCTIONS: This form should be used for transmitting the ISSUE FEE and PUBLICATION FEE (if required). Blocks 1 through 5 should be completed where appropriate. All further correspondence including the Patent, advance orders and notification of maintenance fees will be mailed to the current correspondence address as indicated unless corrected below or directed otherwise in Block 1, by (a) specifying a new correspondence address; and/or (b) indicating a separate "FEE ADDRESS" for maintenance fee notifications.

CURRENT CORRESPONDENCE ADDRESS (Note: Use Block 1 for any change of address)

23364 7590 12/15/2008  
**BACON & THOMAS, PLLC**  
**625 SLATERS LANE**  
**FOURTH FLOOR**  
**ALEXANDRIA, VA 22314-1176**  
**Attn: Benjamin E. Urcia**



Note: A certificate of mailing can only be used for domestic mailings of the Fee(s) Transmittal. This certificate cannot be used for any other accompanying papers. Each additional paper, such as an assignment or formal drawing, must have its own certificate of mailing or transmission.

Certificate of Mailing or Transmission

I hereby certify that this Fee(s) Transmittal is being deposited with the United States Postal Service with sufficient postage for first class mail in an envelope addressed to the Mail Stop ISSUE FEE address above, or being facsimile transmitted to the USPTO (571) 273-2885, on the date indicated below.

(Depositor's name)
(Signature)
(Date)

APPLICATION NO.	FILING DATE	FIRST NAMED INVENTOR	ATTORNEY DOCKET NO.	CONFIRMATION NO.
11/384,371	03/21/2006	Tom Chung	CHUN3098/EM	8664

TITLE OF INVENTION: UNIVERSAL SERIAL BUS (USB) MEMORY PLUG

APPLN. TYPE	SMALL ENTITY	ISSUE FEE DUE	PUBLICATION FEE DUE	PREV. PAID ISSUE FEE	TOTAL FEE(S) DUE	DATE DUE
nonprovisional	YES	\$755	\$300	\$0	\$1055	03/16/2009
EXAMINER		ART UNIT	CLASS-SUBCLASS			
SEMENENKO, YURIY		2841	361-737000	01 FC:2501	755.00 OP	
				02 FC:1504	300.00 OP	

1. Change of correspondence address or indication of "Fee Address" (37 CFR 1.363).

- Change of correspondence address (or Change of Correspondence Address Form PTO/SB/122) attached.
- "Fee Address" indication (or "Fee Address" indication form PTO/SB/47; Rev 03-02 or more recent) attached. Use of a Customer Number is required.

2. For printing on the patent front page, list

- (1) the names of up to 3 registered patent attorneys or agents OR, alternatively,
- (2) the name of a single firm (having as a member a registered attorney or agent) and the names of up to 2 registered patent attorneys or agents. If no name is listed, no name will be printed.

- 1 \_\_\_\_\_
- 2 **Bacon & Thomas, PLLC**
- 3 \_\_\_\_\_

3. ASSIGNEE NAME AND RESIDENCE DATA TO BE PRINTED ON THE PATENT (print or type)

PLEASE NOTE: Unless an assignee is identified below, no assignee data will appear on the patent. If an assignee is identified below, the document has been filed for recordation as set forth in 37 CFR 3.11. Completion of this form is NOT a substitute for filing an assignment.

(A) NAME OF ASSIGNEE

**Phison Electronics Corp.**

(B) RESIDENCE: (CITY and STATE OR COUNTRY)

**Chutung, Hsinchu, Taiwan 310, R.O.C.**

Please check the appropriate assignee category or categories (will not be printed on the patent):  Individual  Corporation or other private group entity  Government

4a. The following fee(s) are submitted:

- Issue Fee
- Publication Fee (No small entity discount permitted)
- Advance Order - # of Copies \_\_\_\_\_

4b. Payment of Fee(s): (Please first reapply any previously paid issue fee shown above)

- A check is enclosed.
- Payment by credit card. Form PTO-2038 is attached.
- The Director is hereby authorized to charge the required fee(s), any deficiency, or credit any overpayment, to Deposit Account Number 02-0200 (enclose an extra copy of this form).

5. Change in Entity Status (from status indicated above)

- a. Applicant claims SMALL ENTITY status. See 37 CFR 1.27.
- b. Applicant is no longer claiming SMALL ENTITY status. See 37 CFR 1.27(g)(2).

NOTE: The Issue Fee and Publication Fee (if required) will not be accepted from anyone other than the applicant; a registered attorney or agent; or the assignee or other party in interest as shown by the records of the United States Patent and Trademark Office.

Authorized Signature *Benjamin E. Urcia* Date 3/3/09  
 Typed or printed name Benjamin E. Urcia Registration No. 33,805

This collection of information is required by 37 CFR 1.311. The information is required to obtain or retain a benefit by the public which is to file (and by the USPTO to process) an application. Confidentiality is governed by 35 U.S.C. 122 and 37 CFR 1.14. This collection is estimated to take 12 minutes to complete, including gathering, preparing, and submitting the completed application form to the USPTO. Time will vary depending upon the individual case. Any comments on the amount of time you require to complete this form and/or suggestions for reducing this burden, should be sent to the Chief Information Officer, U.S. Patent and Trademark Office, U.S. Department of Commerce, P.O. Box 1450, Alexandria, Virginia 22313-1450. DO NOT SEND FEES OR COMPLETED FORMS TO THIS ADDRESS. SEND TO: Commissioner for Patents, P.O. Box 1450, Alexandria, Virginia 22313-1450.

Under the Paperwork Reduction Act of 1995, no persons are required to respond to a collection of information unless it displays a valid OMB control number.



PATENT

IN THE UNITED STATES PATENT AND TRADEMARK OFFICE

IN RE APPLICATION OF: TOM CHUNG ET AL

SERIAL NO.: 11/384,371

FILED: March 21, 2006

FOR: UNIVERSAL SERIAL BUS (USB) MEMORY PLUG

GROUP ART UNIT: 2841

EXAMINER: Y. SEMENENKO

ATTY. REFERENCE: CHUN3098/BEU

COMMISSIONER OF PATENTS

P.O. Box 1450

Alexandria, VA 22313-1450

Sir:

The below identified communication(s) or document(s) is(are) submitted in the above application or proceeding:

- Declaration
- Priority Document
- Formal Drawings
- Issue Fee Transmittal - Part B
- Check - \$1055 (\$755 - IF/\$300-Pub. Fee)
- Application Data Sheet
- Assignment

Please debit or credit Deposit Account Number 02-0200 for any deficiency or surplus in connection with this communication. A duplicate copy of this sheet is provided for use by the Deposit Account Branch.

Small Entity Status is claimed.

23364  
Customer Number

BACON & THOMAS, PLLC  
625 SLATERS LANE - FOURTH FLOOR  
ALEXANDRIA, VIRGINIA 22314  
(703) 683-0500

DATE: March 3, 2009

Respectfully submitted,

Benjamin E. Urcia  
Attorney for Applicant  
Registration Number: 33,805



UNITED STATES PATENT AND TRADEMARK OFFICE

UNITED STATES DEPARTMENT OF COMMERCE  
 United States Patent and Trademark Office  
 Address: COMMISSIONER FOR PATENTS  
 P.O. Box 1450  
 Alexandria, Virginia 22313-1450  
 www.uspto.gov



Bib Data Sheet

CONFIRMATION NO. 8664

<b>SERIAL NUMBER</b> 11/384,371	<b>FILING OR 371(c) DATE</b> 03/21/2006 <b>RULE</b>	<b>CLASS</b> 361	<b>GROUP ART UNIT</b> 2841	<b>ATTORNEY DOCKET NO.</b> CHUN3098/EM
------------------------------------	---	---------------------	-------------------------------	---

**APPLICANTS**  
 Tom Chung, Hsinchu, TAIWAN;  
 Dean Huang, Hsinchu, TAIWAN;  
 Peter Huang, Hsinchu, TAIWAN;

**\*\* CONTINUING DATA \*\*\*\*\***

**\*\* FOREIGN APPLICATIONS \*\*\*\*\***

**IF REQUIRED, FOREIGN FILING LICENSE GRANTED\*\* SMALL ENTITY \*\***  
**\*\* 04/13/2006**

Foreign Priority claimed <input type="checkbox"/> yes <input checked="" type="checkbox"/> no	<b>STATE OR COUNTRY</b> TAIWAN	<b>SHEETS DRAWING</b> 5	<b>TOTAL CLAIMS</b> 18	<b>INDEPENDENT CLAIMS</b> 3	
35 USC 119 (a-d) conditions met <input type="checkbox"/> yes <input checked="" type="checkbox"/> no <input type="checkbox"/> Met after Allowance					
Verified and Acknowledged	Examiner's Signature	Initials			

**ADDRESS**  
23364

**TITLE**  
UNIVERSAL SERIAL BUS (USB) MEMORY PLUG

<b>FILING FEE RECEIVED</b> 525	FEES: Authority has been given in Paper No. _____ to charge/credit DEPOSIT ACCOUNT No. _____ for following:	<input type="checkbox"/> All Fees
		<input type="checkbox"/> 1.16 Fees ( Filing )
		<input type="checkbox"/> 1.17 Fees ( Processing Ext. of time )
		<input type="checkbox"/> 1.18 Fees ( Issue )
		<input type="checkbox"/> Other _____
		<input type="checkbox"/> Credit



UNITED STATES PATENT AND TRADEMARK OFFICE

UNITED STATES DEPARTMENT OF COMMERCE
United States Patent and Trademark Office
Address: COMMISSIONER FOR PATENTS
P.O. Box 1450
Alexandria, Virginia 22313-1450
www.uspto.gov

NOTICE OF ALLOWANCE AND FEE(S) DUE

23364 7590 12/15/2008

BACON & THOMAS, PLLC
625 SLATERS LANE
FOURTH FLOOR
ALEXANDRIA, VA 22314-1176

EXAMINER

SEMENENKO, YURIY

ART UNIT PAPER NUMBER

2841

DATE MAILED: 12/15/2008

Table with 5 columns: APPLICATION NO., FILING DATE, FIRST NAMED INVENTOR, ATTORNEY DOCKET NO., CONFIRMATION NO.

11/384,371 03/21/2006 Tom Chung CHUN3098/EM 8664

TITLE OF INVENTION: UNIVERSAL SERIAL BUS (USB) MEMORY PLUG

Table with 7 columns: APPLN. TYPE, SMALL ENTITY, ISSUE FEE DUE, PUBLICATION FEE DUE, PREV. PAID ISSUE FEE, TOTAL FEE(S) DUE, DATE DUE

nonprovisional YES \$755 \$300 \$0 \$1055 03/16/2009

THE APPLICATION IDENTIFIED ABOVE HAS BEEN EXAMINED AND IS ALLOWED FOR ISSUANCE AS A PATENT. PROSECUTION ON THE MERITS IS CLOSED. THIS NOTICE OF ALLOWANCE IS NOT A GRANT OF PATENT RIGHTS. THIS APPLICATION IS SUBJECT TO WITHDRAWAL FROM ISSUE AT THE INITIATIVE OF THE OFFICE OR UPON PETITION BY THE APPLICANT. SEE 37 CFR 1.313 AND MPEP 1308.

THE ISSUE FEE AND PUBLICATION FEE (IF REQUIRED) MUST BE PAID WITHIN THREE MONTHS FROM THE MAILING DATE OF THIS NOTICE OR THIS APPLICATION SHALL BE REGARDED AS ABANDONED. THIS STATUTORY PERIOD CANNOT BE EXTENDED. SEE 35 U.S.C. 151. THE ISSUE FEE DUE INDICATED ABOVE DOES NOT REFLECT A CREDIT FOR ANY PREVIOUSLY PAID ISSUE FEE IN THIS APPLICATION. IF AN ISSUE FEE HAS PREVIOUSLY BEEN PAID IN THIS APPLICATION (AS SHOWN ABOVE), THE RETURN OF PART B OF THIS FORM WILL BE CONSIDERED A REQUEST TO REAPPLY THE PREVIOUSLY PAID ISSUE FEE TOWARD THE ISSUE FEE NOW DUE.

HOW TO REPLY TO THIS NOTICE:

I. Review the SMALL ENTITY status shown above.

If the SMALL ENTITY is shown as YES, verify your current SMALL ENTITY status:

- A. If the status is the same, pay the TOTAL FEE(S) DUE shown above.
B. If the status above is to be removed, check box 5b on Part B - Fee(s) Transmittal and pay the PUBLICATION FEE (if required) and twice the amount of the ISSUE FEE shown above, or

If the SMALL ENTITY is shown as NO:

- A. Pay TOTAL FEE(S) DUE shown above, or
B. If applicant claimed SMALL ENTITY status before, or is now claiming SMALL ENTITY status, check box 5a on Part B - Fee(s) Transmittal and pay the PUBLICATION FEE (if required) and 1/2 the ISSUE FEE shown above.

II. PART B - FEE(S) TRANSMITTAL, or its equivalent, must be completed and returned to the United States Patent and Trademark Office (USPTO) with your ISSUE FEE and PUBLICATION FEE (if required). If you are charging the fee(s) to your deposit account, section "4b" of Part B - Fee(s) Transmittal should be completed and an extra copy of the form should be submitted. If an equivalent of Part B is filed, a request to reapply a previously paid issue fee must be clearly made, and delays in processing may occur due to the difficulty in recognizing the paper as an equivalent of Part B.

III. All communications regarding this application must give the application number. Please direct all communications prior to issuance to Mail Stop ISSUE FEE unless advised to the contrary.

IMPORTANT REMINDER: Utility patents issuing on applications filed on or after Dec. 12, 1980 may require payment of maintenance fees. It is patentee's responsibility to ensure timely payment of maintenance fees when due.



**PART B - FEE(S) TRANSMITTAL**

Complete and send this form, together with applicable fee(s), to: **Mail Stop ISSUE FEE  
Commissioner for Patents  
P.O. Box 1450  
Alexandria, Virginia 22313-1450**  
or Fax (571)-273-2885

**INSTRUCTIONS:** This form should be used for transmitting the ISSUE FEE and PUBLICATION FEE (if required). Blocks 1 through 5 should be completed where appropriate. All further correspondence including the Patent, advance orders and notification of maintenance fees will be mailed to the current correspondence address as indicated unless corrected below or directed otherwise in Block 1, by (a) specifying a new correspondence address; and/or (b) indicating a separate "FEE ADDRESS" for maintenance fee notifications.

CURRENT CORRESPONDENCE ADDRESS (Note: Use Block 1 for any change of address)

23364 7590 12/15/2008  
BACON & THOMAS, PLLC  
625 SLATERS LANE  
FOURTH FLOOR  
ALEXANDRIA, VA 22314-1176

Note: A certificate of mailing can only be used for domestic mailings of the Fee(s) Transmittal. This certificate cannot be used for any other accompanying papers. Each additional paper, such as an assignment or formal drawing, must have its own certificate of mailing or transmission.

**Certificate of Mailing or Transmission**

I hereby certify that this Fee(s) Transmittal is being deposited with the United States Postal Service with sufficient postage for first class mail in an envelope addressed to the Mail Stop ISSUE FEE address above, or being facsimile transmitted to the USPTO (571) 273-2885, on the date indicated below.

(Depositor's name)
(Signature)
(Date)

APPLICATION NO.	FILING DATE	FIRST NAMED INVENTOR	ATTORNEY DOCKET NO.	CONFIRMATION NO.
11/384,371	03/21/2006	Tom Chung	CHUN3098/EM	8664

TITLE OF INVENTION: UNIVERSAL SERIAL BUS (USB) MEMORY PLUG

APPLN. TYPE	SMALL ENTITY	ISSUE FEE DUE	PUBLICATION FEE DUE	PREV. PAID ISSUE FEE	TOTAL FEE(S) DUE	DATE DUE
nonprovisional	YES	\$755	\$300	\$0	\$1055	03/16/2009

EXAMINER	ART UNIT	CLASS-SUBCLASS
SEMENENKO, YURIY	2841	361-737000

1. Change of correspondence address or indication of "Fee Address" (37 CFR 1.363).

- Change of correspondence address (or Change of Correspondence Address Form PTO/SB/122) attached.  
 "Fee Address" indication (or "Fee Address" Indication form PTO/SB/47; Rev 03-02 or more recent) attached. Use of a **Customer Number is required.**

2. For printing on the patent front page, list

- (1) the names of up to 3 registered patent attorneys or agents OR, alternatively, 1 \_\_\_\_\_  
(2) the name of a single firm (having as a member a registered attorney or agent) and the names of up to 2 registered patent attorneys or agents. If no name is listed, no name will be printed. 2 \_\_\_\_\_  
3 \_\_\_\_\_

3. ASSIGNEE NAME AND RESIDENCE DATA TO BE PRINTED ON THE PATENT (print or type)

PLEASE NOTE: Unless an assignee is identified below, no assignee data will appear on the patent. If an assignee is identified below, the document has been filed for recordation as set forth in 37 CFR 3.11. Completion of this form is NOT a substitute for filing an assignment.

(A) NAME OF ASSIGNEE \_\_\_\_\_ (B) RESIDENCE: (CITY and STATE OR COUNTRY) \_\_\_\_\_

Please check the appropriate assignee category or categories (will not be printed on the patent):  Individual  Corporation or other private group entity  Government

4a. The following fee(s) are submitted:

- Issue Fee  
 Publication Fee (No small entity discount permitted)  
 Advance Order - # of Copies \_\_\_\_\_

4b. Payment of Fee(s): (Please first reapply any previously paid issue fee shown above)

- A check is enclosed.  
 Payment by credit card. Form PTO-2038 is attached.  
 The Director is hereby authorized to charge the required fee(s), any deficiency, or credit any overpayment, to Deposit Account Number \_\_\_\_\_ (enclose an extra copy of this form).

5. Change in Entity Status (from status indicated above)

- a. Applicant claims SMALL ENTITY status. See 37 CFR 1.27.  b. Applicant is no longer claiming SMALL ENTITY status. See 37 CFR 1.27(g)(2).

NOTE: The Issue Fee and Publication Fee (if required) will not be accepted from anyone other than the applicant; a registered attorney or agent; or the assignee or other party in interest as shown by the records of the United States Patent and Trademark Office.

Authorized Signature \_\_\_\_\_ Date \_\_\_\_\_  
Typed or printed name \_\_\_\_\_ Registration No. \_\_\_\_\_

This collection of information is required by 37 CFR 1.311. The information is required to obtain or retain a benefit by the public which is to file (and by the USPTO to process) an application. Confidentiality is governed by 35 U.S.C. 122 and 37 CFR 1.14. This collection is estimated to take 12 minutes to complete, including gathering, preparing, and submitting the completed application form to the USPTO. Time will vary depending upon the individual case. Any comments on the amount of time you require to complete this form and/or suggestions for reducing this burden, should be sent to the Chief Information Officer, U.S. Patent and Trademark Office, U.S. Department of Commerce, P.O. Box 1450, Alexandria, Virginia 22313-1450. DO NOT SEND FEES OR COMPLETED FORMS TO THIS ADDRESS. SEND TO: Commissioner for Patents, P.O. Box 1450, Alexandria, Virginia 22313-1450.

Under the Paperwork Reduction Act of 1995, no persons are required to respond to a collection of information unless it displays a valid OMB control number.



UNITED STATES PATENT AND TRADEMARK OFFICE

UNITED STATES DEPARTMENT OF COMMERCE
United States Patent and Trademark Office
Address: COMMISSIONER FOR PATENTS
P.O. Box 1450
Alexandria, Virginia 22313-1450
www.uspto.gov

Table with 5 columns: APPLICATION NO., FILING DATE, FIRST NAMED INVENTOR, ATTORNEY DOCKET NO., CONFIRMATION NO.
Row 1: 11/384,371, 03/21/2006, Tom Chung, CHUN3098/EM, 8664
Row 2: 23364, 7590, 12/15/2008, [EXAMINER SEMENENKO, YURIY]
Row 3: [ART UNIT 2841] [PAPER NUMBER]
Text: BACON & THOMAS, PLLC, 625 SLATERS LANE, FOURTH FLOOR, ALEXANDRIA, VA 22314-1176
Text: DATE MAILED: 12/15/2008

Determination of Patent Term Adjustment under 35 U.S.C. 154 (b)
(application filed on or after May 29, 2000)

The Patent Term Adjustment to date is 361 day(s). If the issue fee is paid on the date that is three months after the mailing date of this notice and the patent issues on the Tuesday before the date that is 28 weeks (six and a half months) after the mailing date of this notice, the Patent Term Adjustment will be 361 day(s).

If a Continued Prosecution Application (CPA) was filed in the above-identified application, the filing date that determines Patent Term Adjustment is the filing date of the most recent CPA.

Applicant will be able to obtain more detailed information by accessing the Patent Application Information Retrieval (PAIR) WEB site (http://pair.uspto.gov).

Any questions regarding the Patent Term Extension or Adjustment determination should be directed to the Office of Patent Legal Administration at (571)-272-7702. Questions relating to issue and publication fee payments should be directed to the Customer Service Center of the Office of Patent Publication at 1-(888)-786-0101 or (571)-272-4200.

<b>Notice of Allowability</b>	<b>Application No.</b>	<b>Applicant(s)</b>	
	11/384,371	CHUNG ET AL.	
	<b>Examiner</b>	<b>Art Unit</b>	
	YURIY SEMENENKO	2841	

**-- The MAILING DATE of this communication appears on the cover sheet with the correspondence address--**

All claims being allowable, PROSECUTION ON THE MERITS IS (OR REMAINS) CLOSED in this application. If not included herewith (or previously mailed), a Notice of Allowance (PTOL-85) or other appropriate communication will be mailed in due course. **THIS NOTICE OF ALLOWABILITY IS NOT A GRANT OF PATENT RIGHTS.** This application is subject to withdrawal from issue at the initiative of the Office or upon petition by the applicant. See 37 CFR 1.313 and MPEP 1308.

1.  This communication is responsive to 07/24/2008.
2.  The allowed claim(s) is/are 1,2,4-10 and 12-23.
3.  Acknowledgment is made of a claim for foreign priority under 35 U.S.C. § 119(a)-(d) or (f).
  - a)  All    b)  Some\*    c)  None    of the:
    1.  Certified copies of the priority documents have been received.
    2.  Certified copies of the priority documents have been received in Application No. \_\_\_\_\_ .
    3.  Copies of the certified copies of the priority documents have been received in this national stage application from the International Bureau (PCT Rule 17.2(a)).

\* Certified copies not received: \_\_\_\_\_.

Applicant has THREE MONTHS FROM THE "MAILING DATE" of this communication to file a reply complying with the requirements noted below. Failure to timely comply will result in ABANDONMENT of this application.  
**THIS THREE-MONTH PERIOD IS NOT EXTENDABLE.**

4.  A SUBSTITUTE OATH OR DECLARATION must be submitted. Note the attached EXAMINER'S AMENDMENT or NOTICE OF INFORMAL PATENT APPLICATION (PTO-152) which gives reason(s) why the oath or declaration is deficient.
5.  CORRECTED DRAWINGS ( as "replacement sheets") must be submitted.
  - (a)  including changes required by the Notice of Draftsperson's Patent Drawing Review ( PTO-948) attached
    - 1)  hereto or 2)  to Paper No./Mail Date \_\_\_\_\_.
  - (b)  including changes required by the attached Examiner's Amendment / Comment or in the Office action of Paper No./Mail Date \_\_\_\_\_.

**Identifying indicia such as the application number (see 37 CFR 1.84(c)) should be written on the drawings in the front (not the back) of each sheet. Replacement sheet(s) should be labeled as such in the header according to 37 CFR 1.121(d).**
6.  DEPOSIT OF and/or INFORMATION about the deposit of BIOLOGICAL MATERIAL must be submitted. Note the attached Examiner's comment regarding REQUIREMENT FOR THE DEPOSIT OF BIOLOGICAL MATERIAL.

**Attachment(s)**

- |  |   |
|--|---|
| <ol style="list-style-type: none"> <li>1. <input type="checkbox"/> Notice of References Cited (PTO-892)</li> <li>2. <input type="checkbox"/> Notice of Draftsperson's Patent Drawing Review (PTO-948)</li> <li>3. <input checked="" type="checkbox"/> Information Disclosure Statements (PTO/SB/08),<br/>Paper No./Mail Date <u>10/14/08</u></li> <li>4. <input type="checkbox"/> Examiner's Comment Regarding Requirement for Deposit of Biological Material</li> </ol> | <ol style="list-style-type: none"> <li>5. <input type="checkbox"/> Notice of Informal Patent Application</li> <li>6. <input type="checkbox"/> Interview Summary (PTO-413),<br/>Paper No./Mail Date _____ .</li> <li>7. <input type="checkbox"/> Examiner's Amendment/Comment</li> <li>8. <input checked="" type="checkbox"/> Examiner's Statement of Reasons for Allowance</li> <li>9. <input type="checkbox"/> Other _____.</li> </ol> |
|--|---|

*Y. S./*  
Examiner, Art Unit 2841

**DETAILED ACTION**

***Response to Amendment***

1. Amendment filed on 07/24/2008 has been entered.

In response to the Office Action dated 04/25/2008, Applicants have amended all of the claims. Claims 3 and 11 have been cancelled. Claims 19-23 are newly added.

Claims 1, 2, 4-10 and 12-23 are now pending in the application.

***Drawings***

2. The Drawings amendments, filed on 07/24/2008 are considered and acknowledged. The Drawings amendments are approved.

***Specification***

3. The Specification and Title amendments, filed on 07/24/2008 are considered and acknowledged.

***Information Disclosure Statement***

4. The disclosure statement (IDS) filed on 10/14/2008 is considered and is acknowledged. The references are considered an initialed and dated copy of Applicant's IDS form 1449, is attached to the instant Office action.

### ***Response to Arguments***

5. Applicant's arguments filed 07/24/2008 have been fully considered and they are persuasive, because all of the claims amended from "USB memory apparatus" to "USB memory plug".

### ***Allowable Subject Matter***

6. Claims 1, 2, 4 -10 and 12-23 are allowed.

The following is a statement of reasons for the indication of allowance of claims 1, 2, 4-8 and 19: limitations "a print circuit board assembly (PCBA) disposed in said housing, wherein said PCBA is fixed by means of pressing of said plurality of concave props, and a space is formed between said housing and said PCBA" in combination with other claimed limitations in independent claim 1 are not disclosed or suggested by the prior art of record.

Claims 2, 4-8 and 19 are either directly or indirectly dependent upon claim 1.

The following is a statement of reasons for the indication of allowance of claims 9, 10, 12-16 and 20: limitations "said plurality of concave props protrude inward to fix said

Art Unit: 2841

PCBA, and a space is formed between said housing and said PCBA " in combination with other claimed limitations in independent claim 9 are not disclosed or suggested by the prior art of record.

Claims 10, 12-16 and 20 are either directly or indirectly dependent upon claim 9.

The following is a statement of reasons for the indication of allowance of claims 17, 18 and 21-23: limitations "a print circuit board assembly (PCBA) disposed in said housing, wherein said PCBA is fixed by means of pressing of said plurality of concave props " in combination with other claimed limitations in independent claim 17 are not disclosed or suggested by the prior art of record.

Claims 18 and 21-23 are directly dependent upon claim 17.

7. Any inquiry concerning this communication or earlier communications from the examiner should be directed to Yuriy Semenenko whose telephone number is (571) 272-6106. The examiner can normally be reached on 8:30am - 5:00pm.

If attempts to reach the examiner by telephone are unsuccessful, the examiner's supervisor, Dean A. Reichard can be reached on (571)- 272-2800 ext. 31. The fax phone number for the organization where this application or proceeding is assigned is 571-273-8300.

Information regarding the status of an application may be obtained from the Patent Application Information Retrieval (PAIR) system. Status information for published applications may be obtained from either Private PAIR or Public PAIR.

Application/Control Number: 11/384,371

Page 5

Art Unit: 2841

Status information for unpublished applications is available through Private PAIR only.

For more information about the PAIR system, see <http://pair-direct.uspto.gov>. Should

you have questions on access to the Private PAIR system, contact the Electronic

Business Center (EBC) at 866-217-9197 (toll-free).

/Yuriy Semenenko/

/Dean A. Reichard/

Examiner, Art Unit 2841

Supervisory Patent Examiner, Art

Unit 2841





<b>Issue Classification</b>  	<b>Application/Control No.</b> 11384371	<b>Applicant(s)/Patent Under Reexamination</b> CHUNG ET AL.
	<b>Examiner</b> YURIY SEMENENKO	<b>Art Unit</b> 2841

ORIGINAL						INTERNATIONAL CLASSIFICATION														
CLASS		SUBCLASS				CLAIMED					NON-CLAIMED									
361		737				H	0	5	K	1 / 03 (2006.01.01)										
<b>CROSS REFERENCE(S)</b>																				
CLASS	SUBCLASS (ONE SUBCLASS PER BLOCK)																			
174	255																			

<input type="checkbox"/> Claims renumbered in the same order as presented by applicant <input type="checkbox"/> CPA <input type="checkbox"/> T.D. <input type="checkbox"/> R.1.47															
Final	Original	Final	Original	Final	Original	Final	Original	Final	Original	Final	Original	Final	Original	Final	Original
1	1	17	17												
2	2	18	18												
	3	8	19												
3	4	16	20												
4	5	19	21												
5	6	20	22												
6	7	21	23												
7	8														
9	9														
10	10														
	11														
11	12														
12	13														
13	14														
14	15														
15	16														

/YURIY SEMENENKO/ Examiner, Art Unit 2841  (Assistant Examiner)	12/04/2008  (Date)	<b>Total Claims Allowed:</b>  21	
/Dean A. Reichard/  (Primary Examiner)	12/9/08  (Date)	O.G. Print Claim(s)  1	O.G. Print Figure  6

## EAST Search History

Ref #	Hits	Search Query	DBs	Default Operator	Plurals	Time Stamp
L1	2	"20070245047".pn.	US-PGPUB; USPAT; USOCR; EPO; JPO; DERWENT; IBM_TDB	OR	ON	2008/12/04 09:36
L2	12	("20040087213"   "20070066119"   "20070127223"   "20070178769"   "20080064272"   "20080076280").PN.	US-PGPUB; USPAT; USOCR; EPO; JPO; DERWENT; IBM_TDB	OR	ON	2008/12/04 10:44
L3	2	"20040087213".pn.	US-PGPUB; USPAT; USOCR; EPO; JPO; DERWENT; IBM_TDB	OR	ON	2008/12/04 11:26
L4	6	("5335145"   "5991157"   "6781846"   "6781846").PN.	US-PGPUB; USPAT; USOCR; EPO; JPO; DERWENT; IBM_TDB	OR	ON	2008/12/04 11:45
L5	2	"20080064272".pn.	US-PGPUB; USPAT; USOCR; EPO; JPO; DERWENT; IBM_TDB	OR	ON	2008/12/04 11:47
L6	938	361/737.ccls.	US-PGPUB; USPAT; USOCR; EPO; JPO; DERWENT; IBM_TDB	OR	ON	2008/12/04 11:51
L11	2	"6854984".pn.	US-PGPUB; USPAT; USOCR; EPO; JPO; DERWENT; IBM_TDB	OR	ON	2008/12/04 11:57
L12	2	"7297024".pn.	US-PGPUB; USPAT; USOCR; EPO; JPO; DERWENT; IBM_TDB	OR	ON	2008/12/04 12:01
L13	2	"2005348989".pn.	US-PGPUB; USPAT; USOCR; EPO; JPO; DERWENT; IBM_TDB	OR	ON	2008/12/04 12:11

L17	14	("20020116668"   "20030038043"   "20040137664"   "20040143716"   "20040153595"   "20050009388"   "5414597"   "6313400"   "6671808"   "6733329"   "6757783"   "6773192"   "6854984"   "6940153"). PN. OR ("7297024"). URPN.	US-PGPUB; USPAT; USOCR	OR	ON	2008/12/04 12:16
L18	2245	174/255.ccls.	US-PGPUB; USPAT; USOCR; EPO; JPO; DERWENT; IBM_TDB	OR	ON	2008/12/04 13:46
L19	0	(universal and Serial and Bus and memory and plug and hous\$3 and plurality and orientated and indentation and concave and prop and facilitates and connect\$2 insert\$3 and female and USB and socket and print and circuit and board and assembly and PCBA and fixed and means and press\$3 and space). clm.	US-PGPUB	OR	ON	2008/12/04 14:40
L20	0	("361".clas. or "174". clas. or "349".clas.) and (universal and Serial and Bus and memory and plug and hous\$3 and plurality and orientated and indentation and concave and prop and facilitates and connect\$2 insert\$3 and female and USB and socket and print and circuit and board and assembly and PCBA and fixed and means and press\$3 and space). clm.	US-PGPUB	OR	ON	2008/12/04 14:41

L21	0	("361".clas. or "174". clas. or "349".clas.) and (universal and Serial and Bus and memory and plug and hous\$3 and plurality and orientated and indentation and concave and prop and facilitates and connect\$2 insert\$3 and female and USB and socket and print and circuit and board and assembly and PCBA and fixed and means and press\$3 and space)	US-PGPUB; USPAT; USOCR; EPO; JPO; DERWENT; IBM_TDB	OR	ON	2008/12/04 14:42
S1	1	11/384371	US-PGPUB; USPAT; USOCR; EPO; JPO; DERWENT; IBM_TDB	OR	ON	2008/04/08 10:59
S2	975227	"174"/\$.ccls. or "361"/\$. ccls. or "439"/\$.ccls. or "257"/\$.ccls. or "29"/\$. ccls.	US-PGPUB; USPAT; USOCR; EPO; JPO; DERWENT; IBM_TDB	OR	ON	2008/04/08 11:42
S3	1006264	"174"/\$.ccls. or "361"/\$. ccls. or "439"/\$.ccls. or "257"/\$.ccls. or "29"/\$. ccls. or "710"/\$.ccls.	US-PGPUB; USPAT; USOCR; EPO; JPO; DERWENT; IBM_TDB	OR	ON	2008/04/08 11:43
S4	3309	S3 and (((universal with searial with bus) or USB) same memory)	US-PGPUB; USPAT; USOCR; EPO; JPO; DERWENT; IBM_TDB	OR	ON	2008/04/08 11:46
S5	353936	"174"/\$.ccls. or "361"/\$. ccls. or "439"/\$.ccls.	US-PGPUB; USPAT; USOCR; EPO; JPO; DERWENT; IBM_TDB	OR	ON	2008/04/08 11:46
S6	828	S5 and (((universal with searial with bus) or USB) same memory)	US-PGPUB; USPAT; USOCR; EPO; JPO; DERWENT; IBM_TDB	OR	ON	2008/04/08 11:47
S7	3	S5 and (concave with prop)	US-PGPUB; USPAT; USOCR; EPO; JPO; DERWENT; IBM_TDB	OR	ON	2008/04/08 13:12

S8	2100	S5 and (prop)	US-PGPUB; USPAT; USOCR; EPO; JPO; DERWENT; IBM_TDB	OR	ON	2008/04/08 13:15
S9	2	S8 and S6	US-PGPUB; USPAT; USOCR; EPO; JPO; DERWENT; IBM_TDB	OR	ON	2008/04/08 13:16
S10	2	S8 and S4	US-PGPUB; USPAT; USOCR; EPO; JPO; DERWENT; IBM_TDB	OR	ON	2008/04/08 13:18
S11	0	JP-2005-348989-\$.did.	US-PGPUB; USPAT; USOCR; EPO; JPO; DERWENT; IBM_TDB	OR	ON	2008/04/09 07:38
S12	2	JP-2005348989-\$.did.	US-PGPUB; USPAT; USOCR; EPO; JPO; DERWENT; IBM_TDB	OR	ON	2008/04/09 07:38
S13	6	("5335145"   "5991157"   "6781846").PN.	US-PGPUB; USPAT; USOCR; EPO; JPO; DERWENT; IBM_TDB	OR	ON	2008/04/09 07:42
S14	11	("4858070"   "4955131" "5375037"   "5437041"   "5477426"   "5548483"   "5608607"   "5659459"   "5680294"   "5725622"   "5745041"). PN. OR ("6781846"). URPN.	US-PGPUB; USPAT; USOCR	OR	ON	2008/04/09 07:45
S15	85	mitsuhashi-takeshi.in.	US-PGPUB; USPAT; USOCR; EPO; JPO; DERWENT; IBM_TDB	OR	ON	2008/04/09 07:48
S16	1006264	"174"/\$.ccls. or "361"/\$. ccls. or "439"/\$.ccls. or "257"/\$.ccls. or "29"/\$. ccls. or "710"/\$.ccls.	US-PGPUB; USPAT; USOCR; EPO; JPO; DERWENT; IBM_TDB	OR	ON	2008/04/09 10:27

EAST Search History

S17	17	S16 and (((universal with searial with bus) or USB) same memory same LED same EEPROM)	US-PGPUB; USPAT; USOCR; EPO; JPO; DERWENT; IBM_TDB	OR	ON	2008/04/09 10:27
S18	0	11/972388	US-PGPUB; USPAT; USOCR; EPO; JPO; DERWENT; IBM_TDB	OR	ON	2008/04/09 11:48

12/ 4/ 2008 2:47:02 PM

C:\ Documents and Settings\ ysemenenko\ My Documents\ EAST\ Workspaces\ 11384371 .wsp

## EAST Search History

Ref #	Hits	Search Query	DBs	Default Operator	Plurals	Time Stamp
L1	2728	439/607.ccls.	US-PGPUB; USPAT; USOCR; EPO; JPO; DERWENT; IBM_TDB	OR	ON	2008/12/08 13:46
L2	4123	439/607,351-353.ccls.	US-PGPUB; USPAT; USOCR; EPO; JPO; DERWENT; IBM_TDB	OR	ON	2008/12/08 13:46
L3	68	L2 and (USB near plug)	US-PGPUB; USPAT; USOCR; EPO; JPO; DERWENT; IBM_TDB	OR	ON	2008/12/08 13:47
L4	1438	439/351-353.ccls.	US-PGPUB; USPAT; USOCR; EPO; JPO; DERWENT; IBM_TDB	OR	ON	2008/12/08 14:13
S1	1	11/384371	US-PGPUB; USPAT; USOCR; EPO; JPO; DERWENT; IBM_TDB	OR	ON	2008/04/08 10:59
S2	975227	"174"/\$.ccls. or "361"/\$. ccls. or "439"/\$.ccls. or "257"/\$.ccls. or "29"/\$. ccls.	US-PGPUB; USPAT; USOCR; EPO; JPO; DERWENT; IBM_TDB	OR	ON	2008/04/08 11:42
S3	1006264	"174"/\$.ccls. or "361"/\$. ccls. or "439"/\$.ccls. or "257"/\$.ccls. or "29"/\$. ccls. or "710"/\$.ccls.	US-PGPUB; USPAT; USOCR; EPO; JPO; DERWENT; IBM_TDB	OR	ON	2008/04/08 11:43
S4	3309	S3 and (((universal with searial with bus) or USB) same memory)	US-PGPUB; USPAT; USOCR; EPO; JPO; DERWENT; IBM_TDB	OR	ON	2008/04/08 11:46
S5	353936	"174"/\$.ccls. or "361"/\$. ccls. or "439"/\$.ccls.	US-PGPUB; USPAT; USOCR; EPO; JPO; DERWENT; IBM_TDB	OR	ON	2008/04/08 11:46

## EAST Search History

S6	828	S5 and (((universal with searial with bus) or USB) same memory)	US-PGPUB; USPAT; USOCR; EPO; JPO; DERWENT; IBM_TDB	OR	ON	2008/04/08 11:47
S7	3	S5 and (concave with prop)	US-PGPUB; USPAT; USOCR; EPO; JPO; DERWENT; IBM_TDB	OR	ON	2008/04/08 13:12
S8	2100	S5 and (prop)	US-PGPUB; USPAT; USOCR; EPO; JPO; DERWENT; IBM_TDB	OR	ON	2008/04/08 13:15
S9	2	S8 and S6	US-PGPUB; USPAT; USOCR; EPO; JPO; DERWENT; IBM_TDB	OR	ON	2008/04/08 13:16
S10	2	S8 and S4	US-PGPUB; USPAT; USOCR; EPO; JPO; DERWENT; IBM_TDB	OR	ON	2008/04/08 13:18
S11	0	JP-2005-348989-\$.did.	US-PGPUB; USPAT; USOCR; EPO; JPO; DERWENT; IBM_TDB	OR	ON	2008/04/09 07:38
S12	2	JP-2005348989-\$.did.	US-PGPUB; USPAT; USOCR; EPO; JPO; DERWENT; IBM_TDB	OR	ON	2008/04/09 07:38
S13	6	("5335145"   "5991157"   "6781846").PN.	US-PGPUB; USPAT; USOCR; EPO; JPO; DERWENT; IBM_TDB	OR	ON	2008/04/09 07:42
S14	11	("4858070"   "4955131" "5375037"   "5437041"   "5477426" "5548483"   "5608607"   "5659459" "5680294"   "5725622"   "5745041"). PN. OR ("6781846"). URFN.	US-PGPUB; USPAT; USOCR	OR	ON	2008/04/09 07:45

File:///C:/Documents%20and%20Settings/ysemenenko/My%20.4371/EASTSearchHistory.11384371\_AccessibleVersion.htm (2 of 5)12/8/2008 2:29:00 PM



S15	85	mitsubishi-takeshi.in.	US-PGPUB; USPAT; USOCR; EPO; JPO; DERWENT; IBM_TDB	OR	ON	2008/04/09 07:48
S16	1006264	"174"/\$.ccls. or "361"/\$. ccls. or "439"/\$.ccls. or "257"/\$.ccls. or "29"/\$. ccls. or "710"/\$.ccls.	US-PGPUB; USPAT; USOCR; EPO; JPO; DERWENT; IBM_TDB	OR	ON	2008/04/09 10:27
S17	17	S16 and (((universal with searial with bus) or USB) same memory same LED same EEPROM)	US-PGPUB; USPAT; USOCR; EPO; JPO; DERWENT; IBM_TDB	OR	ON	2008/04/09 10:27
S18	0	11/972388	US-PGPUB; USPAT; USOCR; EPO; JPO; DERWENT; IBM_TDB	OR	ON	2008/04/09 11:48
S19	2	"20070245047".pn.	US-PGPUB; USPAT; USOCR; EPO; JPO; DERWENT; IBM_TDB	OR	ON	2008/12/04 09:36
S20	12	("20040087213"   "20070066119"   "20070127223"   "20070178769"   "20080064272"   "20080076280").PN.	US-PGPUB; USPAT; USOCR; EPO; JPO; DERWENT; IBM_TDB	OR	ON	2008/12/04 10:44
S21	2	"20040087213".pn.	US-PGPUB; USPAT; USOCR; EPO; JPO; DERWENT; IBM_TDB	OR	ON	2008/12/04 11:26
S22	6	("5335145"   "5991157"   "6781846"   "6781846").PN.	US-PGPUB; USPAT; USOCR; EPO; JPO; DERWENT; IBM_TDB	OR	ON	2008/12/04 11:45
S23	2	"20080064272".pn.	US-PGPUB; USPAT; USOCR; EPO; JPO; DERWENT; IBM_TDB	OR	ON	2008/12/04 11:47
S24	938	361/737.ccls.	US-PGPUB; USPAT; USOCR; EPO; JPO; DERWENT; IBM_TDB	OR	ON	2008/12/04 11:51

S25	2	"6854984".pn.	US-PGPUB; USPAT; USOCR; EPO; JPO; DERWENT; IBM_TDB	OR	ON	2008/12/04 11:57
S26	2	"7297024".pn.	US-PGPUB; USPAT; USOCR; EPO; JPO; DERWENT; IBM_TDB	OR	ON	2008/12/04 12:01
S27	2	"2005348989".pn.	US-PGPUB; USPAT; USOCR; EPO; JPO; DERWENT; IBM_TDB	OR	ON	2008/12/04 12:11
S28	14	("20020116668"   "20030038043"   "20040137664"   "20040143716"   "20040153595"   "20050009388"   "5414597"   "6313400"   "6671808"   "6733329"   "6757783"   "6773192"   "6854984"   "6940153"). PN. OR ("7297024"). UPPN.	US-PGPUB; USPAT; USOCR	OR	ON	2008/12/04 12:16
S29	2245	174/255.ccls.	US-PGPUB; USPAT; USOCR; EPO; JPO; DERWENT; IBM_TDB	OR	ON	2008/12/04 13:46
S30	0	(universal and Serial and Bus and memory and plug and hous\$3 and plurality and orientated and indentation and concave and prop and facilitates and connect\$2 insert\$3 and female and USB and socket and print and circuit and board and assembly and PCBA and fixed and means and press\$3 and space). clm.	US-PGPUB	OR	ON	2008/12/04 14:40

S31	0	("361".clas. or "174".clas. or "349".clas.) and (universal and Serial and Bus and memory and plug and hous\$3 and plurality and orientated and indentation and concave and prop and facilitates and connect\$2 insert\$3 and female and USB and socket and print and circuit and board and assembly and PCBA and fixed and means and press\$3 and space). clm.	US-PGPUB	OR	ON	2008/12/04 14:41
S32	0	("361".clas. or "174".clas. or "349".clas.) and (universal and Serial and Bus and memory and plug and hous\$3 and plurality and orientated and indentation and concave and prop and facilitates and connect\$2 insert\$3 and female and USB and socket and print and circuit and board and assembly and PCBA and fixed and means and press\$3 and space)	US-PGPUB; USPAT; USOCR; EPO; JPO; DERWENT; IBM_TDB	OR	ON	2008/12/04 14:42
S33	2	"20070297158".pn.	US-PGPUB; USPAT; USOCR; EPO; JPO; DERWENT; IBM_TDB	OR	ON	2008/12/04 15:06

12/ 8/ 2008 2:28:52 PM

C:\ Documents and Settings\ ysemenenko\ My Documents\ EAST\ Workspaces\ 11384371.wsp

<b>Search Notes</b>  	<b>Application/Control No.</b>  11384371	<b>Applicant(s)/Patent Under Reexamination</b>  CHUNG ET AL.
	<b>Examiner</b>  YURIY SEMENENKO	<b>Art Unit</b>  2841

<b>SEARCHED</b>			
Class	Subclass	Date	Examiner
361	737	04/09/2008	YS
439	638	04/09/2008	YS
174	255	04/09/2008	YS
439	351 - 353, 607	12/08/2008	YS
	Above updated on 12/08/2008	12/08/2008	YS

<b>SEARCH NOTES</b>		
Search Notes	Date	Examiner
East, text, search strategy. H. Bui and H. M. Hyeon consulted		
See search history printout	12/08/2008	YS

<b>INTERFERENCE SEARCH</b>			
Class	Subclass	Date	Examiner
	PG Pub text search. Interference search	12/04/2008	YS

/Y. S./ Examiner.Art Unit 2841	
-----------------------------------	--

<b>Index of Claims</b> 	<b>Application/Control No.</b> 11384371	<b>Applicant(s)/Patent Under Reexamination</b> CHUNG ET AL.
	<b>Examiner</b> YURIY SEMENENKO	<b>Art Unit</b> 2841

✓	<b>Rejected</b>
=	<b>Allowed</b>

-	<b>Cancelled</b>
÷	<b>Restricted</b>

N	<b>Non-Elected</b>
I	<b>Interference</b>

A	<b>Appeal</b>
O	<b>Objected</b>

Claims renumbered in the same order as presented by applicant
  CPA
  T.D.
  R.1.47

CLAIM		DATE							
Final	Original	04/09/2008	12/04/2008						
1	1	✓	=						
2	2	✓	=						
	3	✓	-						
3	4	✓	=						
4	5	✓	=						
5	6	✓	=						
6	7	✓	=						
7	8	✓	=						
9	9	✓	=						
10	10	✓	=						
	11	✓	-						
11	12	✓	=						
12	13	✓	=						
13	14	✓	=						
14	15	✓	=						
15	16	✓	=						
17	17	✓	=						
18	18	✓	=						
8		19	=						
16		20	=						
19		21	=						
20		22	=						
21		23	=						



UNITED STATES PATENT AND TRADEMARK OFFICE

UNITED STATES DEPARTMENT OF COMMERCE  
 United States Patent and Trademark Office  
 Address: COMMISSIONER FOR PATENTS  
 P.O. Box 1450  
 Alexandria, Virginia 22313-1450  
 www.uspto.gov

BIB DATA SHEET

CONFIRMATION NO. 8664

<b>SERIAL NUMBER</b> 11/384,371	<b>FILING or 371(c) DATE</b> 03/21/2006 <b>RULE</b>	<b>CLASS</b> 361-235	<b>GROUP ART UNIT</b> 2841	<b>ATTORNEY DOCKET NO.</b> CHUN3098/EM		
<b>APPLICANTS</b> Tom Chung, Hsinchu, TAIWAN; Dean Huang, Hsinchu, TAIWAN; Peter Huang, Hsinchu, TAIWAN;						
** CONTINUING DATA *****						
** FOREIGN APPLICATIONS *****						
** IF REQUIRED, FOREIGN FILING LICENSE GRANTED ** * SMALL ENTITY ** 04/13/2006						
Foreign Priority claimed <input type="checkbox"/> Yes <input checked="" type="checkbox"/> No	35 USC 119(a-d) conditions met <input type="checkbox"/> Yes <input checked="" type="checkbox"/> No	<input type="checkbox"/> Met after Allowance	<b>STATE OR COUNTRY</b> TAIWAN	<b>SHEETS DRAWINGS</b> 5	<b>TOTAL CLAIMS</b> 21-18	<b>INDEPENDENT CLAIMS</b> 3
Verified and /YURIY SEMENENKO/ Examiner's Signature	Initials					
<b>ADDRESS</b> BACON & THOMAS, PLLC 625 SLATERS LANE FOURTH FLOOR ALEXANDRIA, VA 22314-1176 UNITED STATES						
<b>TITLE</b> Universal Serial Bus (USB) memory apparatus						
<b>FILING FEE RECEIVED</b> 500	FEES: Authority has been given in Paper No. _____ to charge/credit DEPOSIT ACCOUNT No. _____ for following:		<input type="checkbox"/> All Fees <input type="checkbox"/> 1.16 Fees (Filing) <input type="checkbox"/> 1.17 Fees (Processing Ext. of time) <input type="checkbox"/> 1.18 Fees (Issue) <input type="checkbox"/> Other _____ <input type="checkbox"/> Credit			

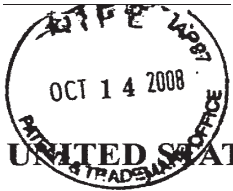

PATENT *DRJ*

IN THE UNITED STATES PATENT AND TRADEMARK OFFICE

IN RE APPLICATION OF: TOM CHUNG ET AL

SERIAL NO.: 11/384,371

FILED: March 21, 2006

FOR: UNIVERSAL SERIAL BUS (USB) MEMORY APPARATUS

GROUP ART UNIT: 2841

EXAMINER: Y. Semenko

ATTY. REFERENCE: CHUN3098/BEU

COMMISSIONER OF PATENTS

P.O. Box 1450

Alexandria, VA 22313-1450

Sir:

The below identified communication(s) or document(s) is(are) submitted in the above application or proceeding:

- Declaration
- Priority Document
- Formal Drawings
- Issue Fee
- Check - \$180
- Information Disclosure Statement  
w/PTO/SB-08A and foreign references
- Assignment

Please debit or credit Deposit Account Number 02-0200 for any deficiency or surplus in connection with this communication. A duplicate copy of this sheet is provided for use by the Deposit Account Branch.

Small Entity Status is claimed.

23364

Customer Number

BACON & THOMAS, PLLC  
625 SLATERS LANE - FOURTH FLOOR  
ALEXANDRIA, VIRGINIA 22314  
(703) 683-0500

Respectfully submitted,

DATE: October 14, 2008

Benjamin E. Urcia  
Attorney for Applicant  
Registration Number: 33,805



PATENT

IN THE UNITED STATES PATENT AND TRADEMARK OFFICE

In re application of:	Tom CHUNG et al	:	
		)	Examiner: Y. Semenenko
Serial No:	11/384,371	:	
		)	Group Art Unit: 2841
Filed:	March 21, 2006	:	
		)	
For:	UNIVERSAL SERIAL BUS (USB) MEMORY APPARATUS	:	
		)	

COMMISSIONER OF PATENTS  
P.O. Box 1450  
Alexandria, VA 22313-1450

INFORMATION DISCLOSURE STATEMENT

Sir:

Pursuant to Rule 37 C.F.R. §1.51(b), §1.56, §1.97, and §1.98, this Information Disclosure Statement is submitted in the above-identified patent application. A listing of documents to be published on the face of any patent granted from this application is submitted herewith on Form PTO-1449. Any other documents or information submitted for consideration by the Examiner are listed in this paper. A copy of each U.S. and foreign patent, or each publication or portion thereof listed or herein identified is submitted herewith, except that a copy of any U.S. patent application identified herein or any patent, publication or other information listed herein cited or submitted in a prior application relied upon for an earlier filing date under 35 U.S.C. §120 and identified below, is not submitted herewith.

CONCISE STATEMENT OF RELEVANCY  
(Non-English Language Documents Only)

Chinese Publication Nos. 1632987 and 2731910, and Japanese Patent Publication No. 3099411, are cited for their illustrations of USB connectors with circuit boards, but which lack "props" as claimed in the present application. Chinese Patent Publication No. 2142631 is cited for its illustration computer housing with structures resembling props, though no USB connector is shown. The relevance of Japanese Patent Publication No. 2004-103907 is evident from the English language abstract and drawings.

10/15/2008 SZEWDIE1 00000044 11384371

01 FC:1806

100.00 OP



STATEMENT REGARDING TRANSLATIONS

Translations of the non-English language documents are not readily available

This Information Disclosure Statement is submitted after three months from (i) the filing date of the above-identified U.S. National Patent application, or (ii) after three months from entry into the U.S. National Stage of the above-identified International Application, or (iii) the date of entry into the U.S. National Stage of the International Application that has been assigned the above-identified U.S. Patent application number, whichever applies; and after the mailing date of the first Office Action on the merits of the above-identified application, but prior to issuance of the earlier of any Final Action or Notice of Allowance sent in such application. The fee required under 37 C.F.R. §1.97(c) and §1.17(p) is submitted herewith.

The Examiner is requested to acknowledge consideration of the information provided in this paper in accordance with prescribed procedures.

Respectfully submitted,  
Benjamin E. Urcia



---

Registration No. 33,805

Date: October 14, 2008

**23364**

Customer Number

Telephone: (703) 683-0500

S:\Producer\beu\Pending A...H\C\CHUNG 384371\Information Disclosure Statement (new).wpd



[19] 中华人民共和国国家知识产权局

[51] Int. Cl<sup>7</sup>

H01R 24/06

H01R 12/00



# [12] 发明专利申请公开说明书

[21] 申请号 200410103966.4

[43] 公开日 2005 年 6 月 29 日

[11] 公开号 CN 1632987A

[22] 申请日 2004. 12. 31

[21] 申请号 200410103966. 4

[71] 申请人 瑞程科技股份有限公司

地址 台湾省新竹县

[72] 发明人 李钟亮 林传生 蔡瑞隆

[74] 专利代理机构 北京律诚同业知识产权代理有限公司

代理人 梁 挥 祁建国

权利要求书 2 页 说明书 8 页 附图 7 页

[54] 发明名称 USB 应用装置

[57] 摘要

本发明公开了一种 USB 应用装置，以一 PCB 电路板作为一连接头的 PCB 承载板，PCB 承载板的顶表面可用来承载多个第一连接端子，而 PCB 承载板的底表面与连接头的外壳层之间则形成有一板底夹层，板底夹层内部可用来固设有至少一电子组件，通过这个可以选择缩减 USB 电子应用模块的长度，或是增加 USB 电子应用模块的工作效率和功能，同时在 PCB 承载板未设置有第一连接端子的部分顶表面上，设置至少一板顶数据传输线路，可有效提升 USB 应用装置的工作效率和功能。

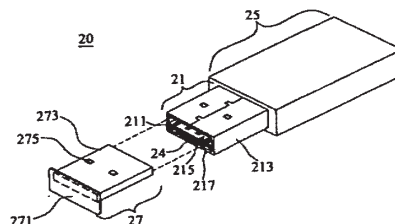

知识产权出版社出版

1. 一种 USB 应用装置，包括连接有一 USB 电子应用模块的连接头，其中，该连接头内包括一外壳层包围的承载板，该承载板的顶表面与该外壳层之间形成有一连接夹层，该承载板的顶表面设置有多个与该 USB 电子应用模块电连接的第一连接端子，该连接夹层与一相对应的 USB 连接座相互插接，USB 连接座插接于该连接夹层内时，该第一连接端子与多个设置于该 USB 连接座内的第二连接端子电连接，该连接头内部的承载板底表面与外壳层之间形成有一板底夹层，该承载板的底表面上设置有至少一电子组件。
2. 根据权利要求 1 所述的 USB 应用装置，其特征在于，该承载板的材料是一电路板、塑料、塑钢或聚合物。
3. 根据权利要求 1 所述的 USB 应用装置，其特征在于，该连接头的外壳层以一非金属材料制成，该 USB 电子应用模块内设有一应用电路板，该承载板是一电路板所制成的 PCB 承载板，该应用电路板与该 PCB 承载板以一体成型方式形成，该电子组件是一控制电路或一板底数据传输线路，该 USB 电子应用模块外包围有一模块外壳层，该模块外壳层与该连接头的外壳层以一体成型方式形成。
4. 根据权利要求 1 所述的 USB 应用装置，其特征在于，该板底夹层内设置有至少一与该承载板连接的支撑构造或前端保护层或该支撑构造与前端保护层的组合，该承载板的顶表面设置有另一数据传输线路。
5. 根据权利要求 1 所述的 USB 应用装置，其特征在于，还包括有一保护塞，该保护塞具有一外露端，该外露端横向连接有一插入端，该插入端可插入该连接夹层内，该保护塞的外露端的截面积大于该连接头的截面积；该 USB 电子应用模块是一内存、移动硬盘、Blue tooth、数码相机、MP3 随身听、控制电路、GPS、录音笔、电视收视模块、无线网络卡模块、系统主机或其组合，或是一 USB 连接线。
6. 一种 USB 应用装置，包括连接有一 USB 电子应用模块的连接头，其中，该连接头内包括有以一非金属外壳层包围的一承载板，该承载板的顶表面与该外壳层之间形成有一连接夹层，承载板的顶表面设置有多个与该 USB 电子应用模块电连接的第一连接端子，而该连接夹层与一相对应的 USB 连接座相互插接，当 USB 连接座插接于连接夹层内时，该第一连接端子与多个设置于该 USB 连接座内的第二连接端子电连接。

7. 根据权利要求6所述的USB应用装置,其特征在于,还包括有一包围该USB电子应用模块的模块外壳层,该模块外壳层与该连接头的外壳层以一体成型方式形成,该承载板的顶表面增加设置有至少一数据传输线路。

8. 一种USB应用装置,包括内部设置有一承载板的连接头,该承载板的顶表面  
5 设置有多于一个第一连接端子,该第一连接端子包括一VCC电源线路、一GND电源线路、一第一数据传输线路及一第二数据传输线路,该承载板顶表面末端部分设置有至少一数据传输线路。

9. 一种USB应用装置,包括连接有一USB电子应用模块的连接头,其中,该连接头内包括有以一外壳层包围的一承载板,该承载板的顶表面与该外壳层之间形成有一连接夹层,可与一标准Series A USB连接座相互插接。  
10

10. 根据权利要求9所述的USB应用装置,其特征在于,该连接头的外壳层由一非金属材料制成;该USB电子应用模块是内存、移动硬盘、Blue tooth、数码相机、MP3随身听、控制电路、GPS、录音笔、电视收视模块、无线网络卡模块、系统主机或其组合;该连接头的外壳层与该电子应用模块的模块外壳层以一体成型方式形成。

11. 根据权利要求9所述的USB应用装置,其特征在于,该连接头的厚度在0.25公分到0.4公分之间。  
15

## USB 应用装置

### 5 技术领域

本发明涉及种 USB 应用装置，特别是涉及一种以一 PCB 电路板作为一接头内部承载板的改良结构，不仅可缩减 USB 应用装置的长度，也可有效提升 USB 应用装置的工作效率和功能。

### 10 背景技术

USB (Universal Serial Bus) 传输接口由于具有使用上的便捷性、扩充性和高传输速度等优点，因此被广泛应用于各种计算机外设装置、信息家电产品(LA)或 3C 消费性电子产品中，是现今人们工作和家庭生活中不可或缺的传输接口工具。

现有的 USB 装置端结构如图 1 及图 2 所示，具有 USB 接头 11 (Series A Plug) 的 USB 应用装置 10，如 MP3 随身听或录音笔等储存记忆装置，其前端主要是为一 USB 接头 11，该 USB 接头 11 的外部构造为一金属外壳层 113，以环设方式包围有一承载板 111，该承载板 111 底表面紧贴于外壳层 113 的内部下表面，而承载板 111 的顶表面则与外壳层 113 的内部上表面之间自然形成有一可与另一 USB 连接座 (Series A Receptacle) 相连接的连接夹层 115。

承载板 111 的顶表面设有多个连接端子 13，分别是一 VCC 电源线路 131、一 GND 电源线路 137、一 D+ 数据传输线路 133 及一 D- 数据传输线路 135，其中 D+ 数据传输线路 133 及 D- 数据传输线路 135 可用来进行数据传输，VCC 电源线路 131 及 GND 电源线路 137 则可接受来自一 USB 主机或电源供应器的工作电流。

USB 接头 11 的后端连设有一长度为 L1 的 USB 电子应用模块 15，该 USB 电子应用模块 15 以一外壳层 155 包围有一电路板 157，并在电路板 157 的表面固设有一可用来储存数据的存储元件 153 及一控制电路 151，该控制电路 151 的两端分别连接存储元件 153 及连接端子 13，并作为两者之间数据传输或储存的控制装置。此外，还可设有一保护盖 17，该保护盖 17 以外罩方式包围 USB 接头 11，以达到保护该 USB 接头的目的。

上述现有的 USB 应用装置 10 中，承载板 111 为实心树脂材料，而其唯一功能仅

是用来承载及固定 USB 连接端子 13, 然而却因此占据了 USB 连接头 11 相当大的体积部分, 相对也就形成了 USB 应用装置 10 的体积或长度难以缩减, 因此就 USB 应用装置 10 的制作成本和携带方便性而言, 均造成相当程度的浪费与不便。

5 现有的 USB 连接头 11 中, 该承载板 111 的顶表面仅有一 VCC 电源线路 131、一 GND 电源线路 137、一 D+ 传输线路 133 及一 D- 传输线路 135, 其数据传输线路明显不足, 因此, 其工作效率和功能也遭受到限制, 无法胜任现今信息时代对于信息产品效率和功能的要求。

10 现有 USB 应用装置 10 的保护盖 17, 以外罩方式固定于 USB 连接头 11 的外表面, 此种固设方式虽然可达到保护 USB 连接头 11 的目的, 但同时也增加了 USB 应用装置 10 的整体体积。

同时现有 USB 连接头 11 与 USB 外壳层 155 以不同的材料所制成, 因此在制造过程中, 两者要先分别制作后再进行黏合, 不但增加了制造上的繁琐, 且在黏合过程中若有黏合效果不好的情形, 将使得 USB 连接头 11 与 USB 外壳层 155 之间产生摇晃, 长久使用下将造成 USB 应用装置 10 内部连接线路的毁坏。

15

#### 发明内容

因此, 本发明的目的在于针对上述 USB 连接头及 USB 应用装置的构造缺点, 设计出一种新颖的 USB 应用装置, 不但可有效缩小 USB 应用装置的长度, 又可增加 USB 应用装置的工作效率和功能, 同时连接头的外壳层及 USB 模块外壳层选择相同材料, 以一体成型方式形成, 以减化 USB 应用装置的制造流程及降低制造成本。

20 为了实现上述目的, 本发明提供了一种 USB 应用装置, 包括连接有一 USB 电子应用模块的连接头, 其中, 该连接头内包括一外壳层包围的承载板, 该承载板的顶表面与该外壳层之间形成有一连接夹层, 该承载板的顶表面设置有多个与该 USB 电子应用模块电连接的第一连接端子, 该连接夹层与一相对应的 USB 连接座相互插接, 25 USB 连接座插接于该连接夹层内时, 该第一连接端子与多个设置于该 USB 连接座内的第二连接端子电连接, 该连接头内部的承载板底表面与外壳层之间形成有一板底夹层, 该承载板的底表面上设置有至少一电子组件。

30 为了更好的实现上述目的, 本发明还提供了一种 USB 应用装置, 包括连接有一 USB 电子应用模块的连接头, 其中, 该连接头内包括有以一非金属外壳层包围的一承载板, 该承载板的顶表面与该外壳层之间形成有一连接夹层, 承载板的顶表面设置有

多个与该 USB 电子应用模块电连接的第一连接端子，而该连接夹层与一相对应的 USB 连接座相互插接，当 USB 连接座插接于连接夹层内时，该第一连接端子与多个设置于该 USB 连接座内的第二连接端子电连接。

为了更好的实现上述目的，本发明还提供了一种 USB 应用装置，包括一内部设置有一承载板的连接头，该承载板的顶表面设置有多个第一连接端子，该第一连接端子包括一 VCC 电源线路、一 GND 电源线路、一第一数据传输线路及一第二数据传输线路，该承载板顶表面末端部分设置有至少一数据传输线路。

为了更好的实现上述目的，本发明还提供了一种 USB 应用装置，包括连接有一 USB 电子应用模块的连接头，其中，该连接头内包括有以一外壳层包围的一承载板，该承载板的顶表面与该外壳层之间形成有一连接夹层。

本发明的 USB 应用装置缩减了 USB 应用装置长度，增加了 USB 应用装置的工作效率和功能。同时通过单一连接头内增加设置有其它数据传输线路，提高了 USB 应用装置的信号传输频宽及传输速度，其保护塞可以直接插入承载板顶表面及外壳层所预留的连接夹层内，不仅可达到保护连接头之目的，也可有效缩小 USB 应用装置的整体体积。最后连接头的外壳层及 USB 模块外壳层选择相同材料，并以一体成型方式形成，减化了 USB 应用装置的制造流程及降低制造成本。

下面结合附图和实施例对本发明进行详细说明。

#### 附图说明

- 图 1 是现有 USB 应用装置的立体示意图；  
图 2 是现有 USB 应用装置的构造剖视图；  
图 3 是本发明 USB 应用装置一实施例的立体示意图；  
图 3A 是本发明如图 3 所示实施例的局部构造剖视图；  
图 4 是本发明 USB 应用装置一实施例的仰视构造截面图；  
图 5 是本发明 USB 应用装置一实施例的立体示意图；  
图 6 是本发明 USB 应用装置一实施例的立体示意图；  
图 6A 是本发明图 6 所示实施例的局部构造剖视图；  
图 7 是本发明 USB 应用装置一实施例的立体示意图；及  
图 8 是本发明 USB 应用装置一实施例的立体示意图。
- 其中，附图标记：



	10	USB 应用装置	11	USB 连接头
	111	承载板	113	外壳层
	115	连接夹层	13	连接端子
	131	VCC 电源线路	133	D+数据传输线路
5	135	D-数据传输线路	137	GND 电源线路
	15	USB 电子应用模块	151	控制电路
	153	存储元件	155	外壳层
	157	电路板	17	保护盖
	20	USB 应用装置	200	USB 应用装置
10	21	连接头	211	PCB 承载板
	213	外壳层	215	连接夹层
	217	板底夹层	218	支撑构造
	219	前端保护层	23	第一连接端子
	231	VCC 电源线路	233	第一数据传输线路
15	235	第二数据传输线路	237	GND 电源线路
	24	电子组件	25	USB 电子应用模块
	251	控制电路	253	记忆装置
	255	模块外壳层	257	应用电路板
	27	保护塞	271	外露端
20	273	插入端	275	固定装置
	32	底部数据传输线路	320	底部空隙
	321	第五数据传输线路	322	第三数据传输线路
	323	第四数据传输线路	324	第六数据传输线路
	325	第七数据传输线路	326	第八数据传输线路
25	327	第九数据传输线路	40	USB 应用模块
	41	连接头	411	PCB 承载板
	413	外壳层	417	板底夹层
	43	第一连接端子	431	VCC 电源线路
	432	底部数据传输线路	433	第一数据传输线路
30	435	第二数据传输线路	437	GND 电源线路

	45	USB 电子应用模块	49	板底数据传输线路
	50	USB 应用装置	51	连接头
	513	外壳层	55	USB 电子应用模块
	555	模块外壳层	60	USB 应用装置
5	600	USB 外壳层	61	连接头
	613	外壳层	65	USB 电子应用模块
	655	模块外壳层		

### 具体实施方式

10 如图3和图3A所示,本发明的USB应用装置20,如移动硬盘、Blue tooth、数码相机、MP3随身听、控制电路、GPS、录音笔、电视收视模块或无线网络卡模块等装置,其前端设有一连接头(Series A Plug)21,连接头21的后端连设有一USB电子应用模块25。其中,该连接头21的外壳层213内包围有一由PCB电路板所制成的PCB承载板211,在PCB承载板211顶表面与外壳层213之间可自然形成有一连接夹层215, 15 该连接夹层215可与另一连接座(Series A receptacle)相互插接,而连接夹层215内的PCB承载板211顶表面上,可承载多个与电子应用模块25电连接的第一连接端子23。当连接夹层215与相对应的USB连接座相互插接时,该第一连接端子23可与USB连接座内的第二连接端子(71;如第8图所示)电连接。

在PCB承载板211底表面与外壳层213之间也自然形成有一板底夹层217,该板 20 底夹层217内部可用来设置至少一电子组件24或一板底数据传输线路,该电子组件24可设计为另一组可增加工作效率和功能的工作组件;而板底数据传输线则可增加传输功能,通过这个来增加USB应用装置20的工作效率和功能。另外,该连接头21的外壳层213可选择塑料、塑钢或聚合物等非金属材料制成,并与电子应用模块25的模块外壳层255以一体成型的方式设置。而连接头21内部的PCB承载板211也可 25 与电子应用模块25内部的应用电路板257以一体成型的方式形成。

配合连接头21的大小设有一保护塞27,该保护塞27以一外露端271横向连接一插入端273,其中插入端273的截面积比连接夹层215的截面积小,通过这个可将保护塞27的插入端273直接插入该连接夹层215内部,不但可保护连接头21,也可缩小USB应用装置20体积。同时,在插入端273外表面可增加至少一固定装置275, 30 该固定装置275可设计为一卡榫,使得保护塞27更牢固的固定于连接头21上。当欲

取出保护塞 27 时, 仅需按压该固定装置 275 后, 再将保护塞 27 拔出即可。保护塞 27 的外露端 271 截面积比连接头 21 的外壳层 213 截面积大, 以有利于保护塞 27 的抽取动作进行。

如图 3 和图 4 所示, USB 应用装置 200 中的 PCB 承载板 211 底表面设置有一控制电路 251, 由于现有承载板 111 的厚度约为 1.9mm 至 2mm, 而电路板 211 的厚度一般约为 0.3mm 至 0.7mm, 且控制电路 251 的厚度约为 1.2mm 至 0.65mm, 因此该电路板 211 与控制电路 251 堆叠之后, 其总厚度还是小于现有 USB 应用装置 10 的承载板 111 的厚度。因此, 可将原本设于 USB 电子应用模块 25 内的部分电子组件或控制电路 251 置放于 PCB 承载板 211 底表面及外壳层 213 之间所自然形成的板底夹层 217 内部, 并以该控制电路 251 作为第一连接端子 23 及 USB 电子应用模块 25 内的记忆装置 253 的连接接口, 通过这个使得本发明 USB 电子应用模块 25 的长度 L2 缩减, 比现有 USB 电子应用模块 15 的长度 L1 短, 这样就可以缩减该 USB 应用装置 20 的长度。

上述的 USB 电子应用模块 25 中, 一模块外壳层 255 包围一应用电路板 257, 其中, 该应用电路板 257 与连接头 21 内部的 PCB 承载板 211 以一体成型的方式形成, 如此可省却现有技术中分别制造两个不同的组件再进行黏合的步骤, 可有效缩短制造所花费的时间, 并降低制造成本。同时, 若 PCB 承载板 211 及应用电路板 257 以一体成型方式设置时, 不但可增强整体结构强度, 也可提高组件间线路连接的稳定度, 通过这个又可增加该 USB 应用装置 200 的耐用性。

如图 4 和图 3A 所示, 上述连接头 21 内部的 PCB 承载板 211 的底表面与外壳层 213 之间所形成的板底夹层 217 内部, 可增加设置有至少一支撑装置 218, 该支撑装置 218 可用来稳固该板底夹层 217, 并防止该板底夹层 217 受力变形。该板底夹层 217 与外界的交接面, 设有一前端保护层 219, 该前端保护层 219 可用来保护该板底夹层 217 内部的电子组件 24 或控制电路 251, 同时也可有效强化板底夹层 217 架构。

在本发明另一实施例中, 如图 5 所示, PCB 承载板 211 的顶表面设置有多个第一连接端子 23, 该第一连接端子 23 可包括有一 VCC 电源线路 231、一 GND 电源线路 237、一第一数据传输线路 233 及一第二数据传输线路 235。其中, 第一数据传输线路 233 及第二数据传输线路 235 可被设计为一相对应的 D+/D- 差分对传输线路, 增加 USB 抗噪声能力。同时, PCB 承载板 211 顶表面其它部分位置也可增加设置一第三数据传输线路 322、一第四数据传输线路 323 及一第五数据传输线路 321。同时 PCB 承载板 211 上各数据传输线路 233、235、321、322 及 323 后端的底部空隙 320 上又增

加设置有一底部数据传输线路 32，该底部数据传输线路 32 可包括有一第六数据传输线路 324、第七数据传输线路 325、第八数据传输线路 326 或第九数据传输线路 327 等，其可与第一数据传输线路 233、第二数据传输线路 235、第三数据传输线路 322、第四数据传输线路 323 及第五数据传输线路 321 共同组成为一 signal 0 (clock)、signal 1 ~ signal 3、signal 5~ signal 8 的第三排信号传输线 (clock+8-bit data bus)，通过这个可增加 USB 应用装置 20 的工作项目及工作效率和功能。

当然，第一数据传输线 233 及第二数据传输线 235 也可直接设计为一非 D+/D-差分对规格的传输线路，以利数据的传输。

另外，如图 6 和图 6A 所示，本发明具有 USB 传输接口的 USB 应用装置包括有一连接头 41，并在连接头 41 后端连接有一 USB 电子应用模块 45，而本实施例中所展示的 USB 应用装置 40 为一 USB 连接线，该连接头 41 中，一外壳层 413 包围有一 PCB 承载板 411，PCB 承载板 411 顶表面可用来设置有多个第一连接端子 43，该第一连接端子 43 包括有一 VCC 电源线路 431、一 GND 电源线路 437、一第一数据传输线路 433 及一第二数据传输线路 435，并在 PCB 承载板 411 末端设有第一连接端子 43 的顶表面上，增加设置有至少一底部数据传输线路 432。

该 PCB 承载板 411 底表面与外壳层 413 之间自然形成有一板底夹层 417，其内可用来容纳一电子组件或另一组板底数据传输线路 49，该板底数据传输线路 49 可在连接座设有相对应的传输线路的情形下，用来传输第二组信号，如此可有效提高该 USB 连接线的传输速度或工作效率和功能。若当连接座 (70；如第 8 图所示) 没有设置相对应的传输线路时，该 USB 连接器 40 也可以第一数据传输线路 433 及一第二数据传输线路 435 进行现有的数据传输。

在本实施例中，该连接头 41 内部的 PCB 承载板 411，也可选择为一不具电路板特性的材料所制造，如此，该 PCB 承载板 411 的材料选择将更加多元化。

如图 7 和图 1 所示，本发明以一连接头 51 连接一电子应用模块 55，其中该连接头 51 以一外壳层 513 包围一承载板 511，并将该承载板 511 的厚度加以缩减，使得该连接头 51 的厚度 H2 小于习用连接头 11 的厚度 H1，而在此实施例中，该连接头 51 的厚度 H2 可低于 0.4 公分。如承载板 511 的厚度约为 0.3mm 至 1mm，而该连接夹层 515 的厚度约为 1.5mm 至 2.5mm，两者层迭设置的总厚度约为 1.8mm 至 3.5mm，若再以一外壳层 513 包围该承载板 511 及连接夹层 515，则该连接头 51 的最佳厚度将介于 0.25 公分至 0.4 公分之间。

此外，该承载板 511 顶表面与外壳层 513 之间所形成的连接夹层 515 与现有连接夹层（115）的容纳空间相同，如此该连接头 51 将可与现有的 USB 连接座（70；如第 8 图所示）相互插接，并达到数据传输的目的。同时，USB 电子应用模块 55 的厚度若配合该连接头 51 的厚度 H2 缩减，可有效降低该 USB 应用装置 50 的厚度，使得该 5 USB 应用装置 50 可如同插卡式的应用装置。

如图 8 所示，本发明一具有 USB 传输接口的 USB 应用装置 60 的连接头 61 的外壳层 613 及连接头 61 后端所连接的 USB 电子应用模块 65 的模块外壳层 655，以一体成型的方式设置，而成为一 USB 外壳层 600，该 USB 外壳层 600 的材料可选择塑料、塑钢或聚合物等非金属材料，如此便可将习用外壳层 613 及模块外壳层 655 必须分别 10 制作后再进行连结的步骤省略，减化制程的步骤，并提高生产效率。

USB 外壳层 600 可通过不同材料的选择，以达到 USB 应用装置 60 之外观变化及降低制造成本之目的，例如，若选择以塑料作为 USB 外壳层 600 的材料时，因为塑料价格较金属低，可有效降低原料对象所使用的成本。且，塑料的重量也比金属轻，故可减轻该 USB 应用装置 60 的重量。当然，选择塑料材料制作 USB 外壳层 600 时，其 15 连接接口边缘也不像金属材料锋利，因此，可有效提升其使用上的安全性。若 USB 外壳层 600 所选择的材料改变，对该 USB 应用装置 60 的外观而言将有相当程度的影响，通过这个，不但可增加 USB 应用装置 60 的选择种类，也可美化其整体外观，而刺激消费欲望。

另外，虽然本发明在前述实施例中均以一电路板为材质所制成的 PCB 承载板来作为叙述对象，但在本发明不同实施例中，其承载板也可选择由其它非电路板材质所制成，例如塑料、塑钢或各种聚合物等，同样可达到本发明的发明目的及功效。 20

当然，本发明还可有其他多种实施例，在不背离本发明精神及其实质的情况下，熟悉本领域的技术人员当可根据本发明作出各种相应的改变和变形，但这些相应的改变和变形都应属于本发明所附的权利要求的保护范围。



图 1



图 2

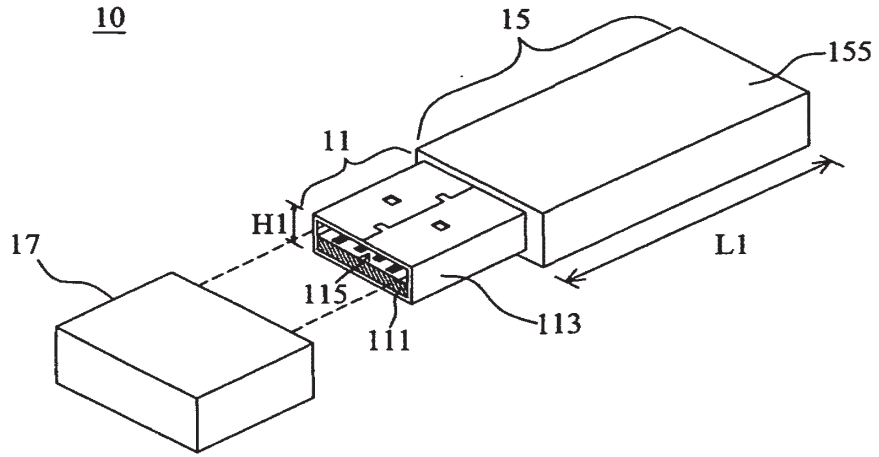

图 3

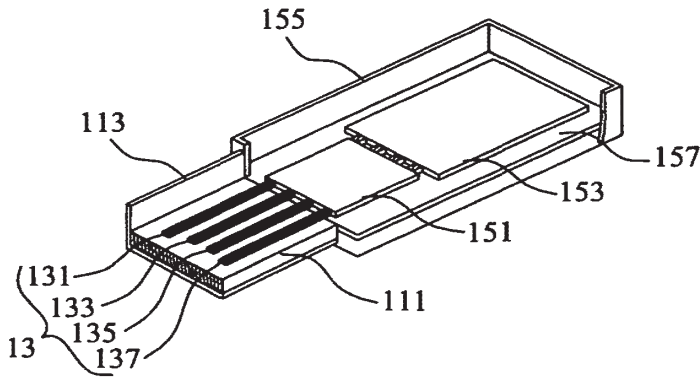

图 3A

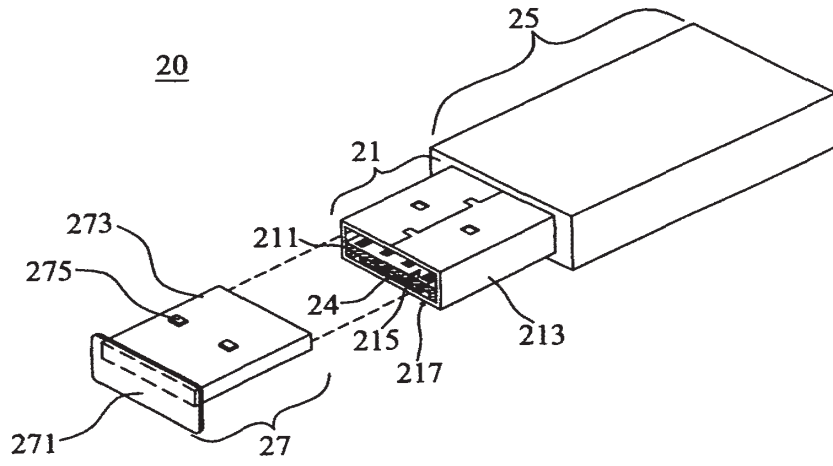

图 4



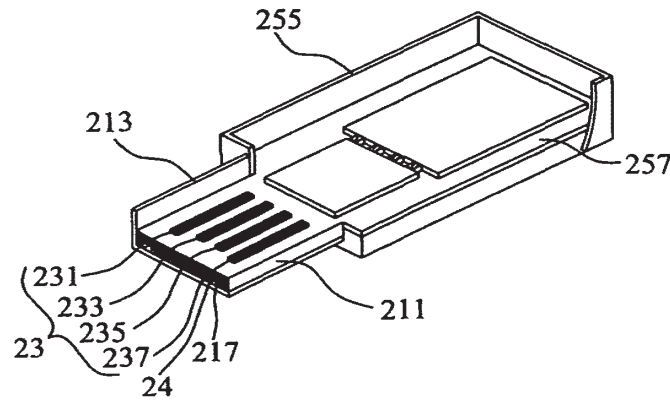

图 5

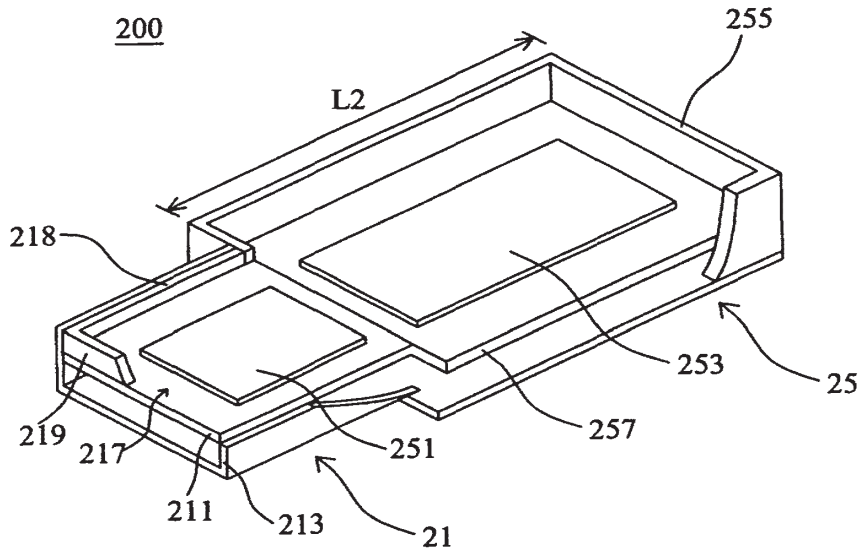

图 6

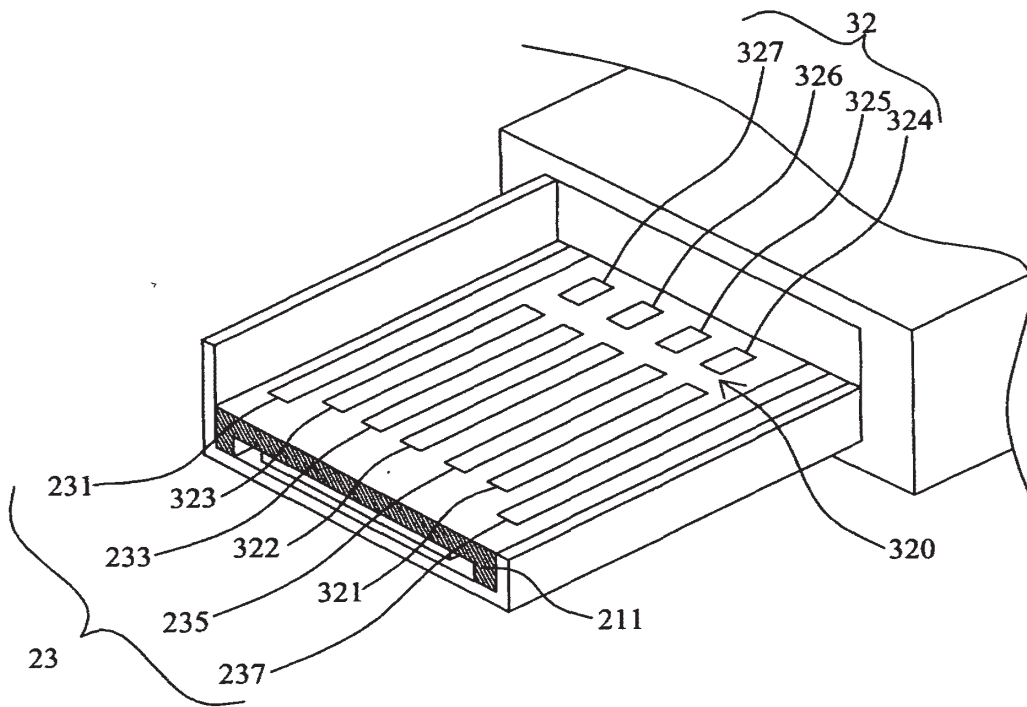

图 6A

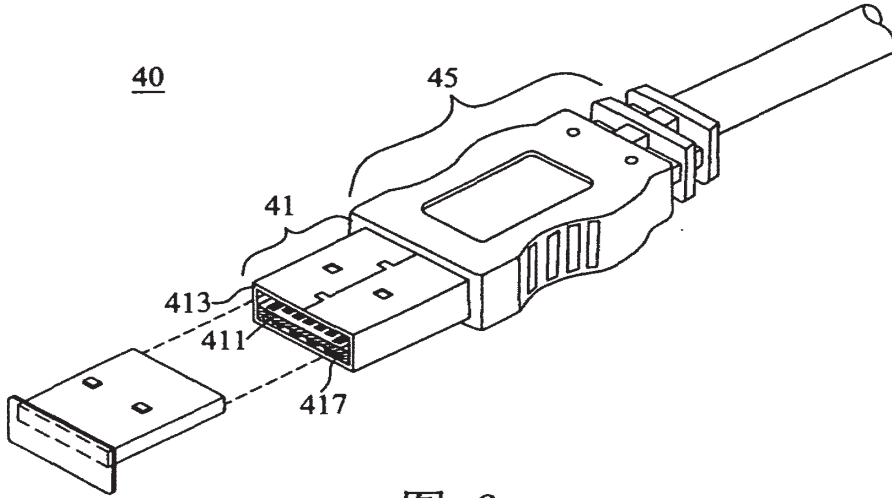

图 7

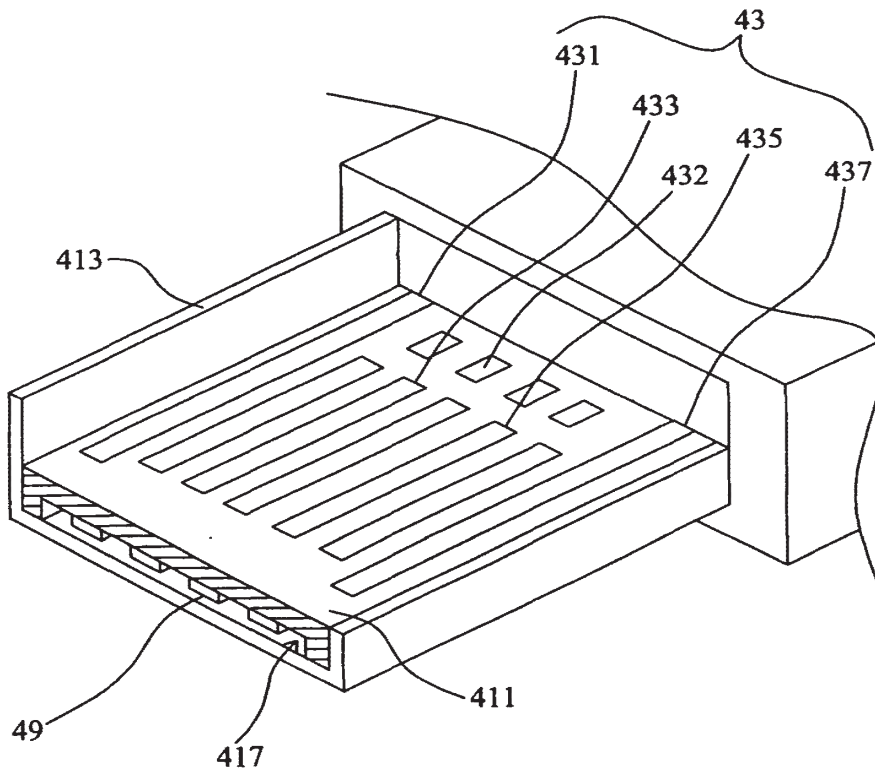

图 8

[19] 中华人民共和国国家知识产权局

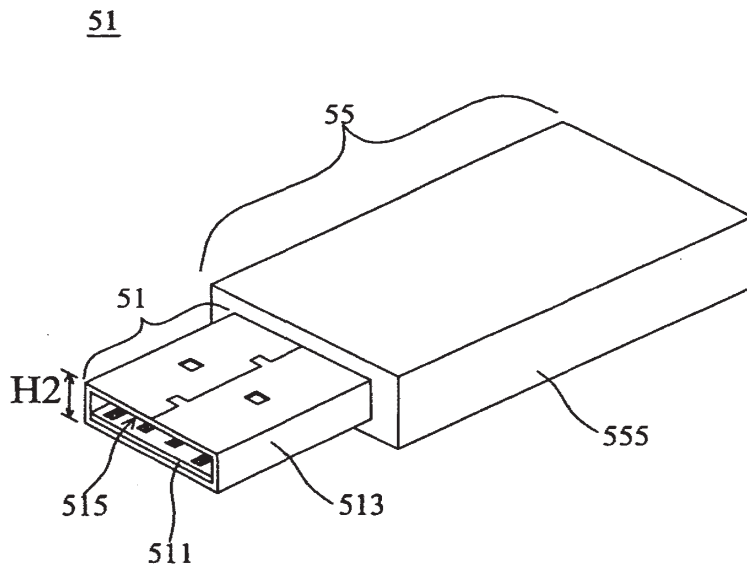
[51] Int. Cl<sup>7</sup>

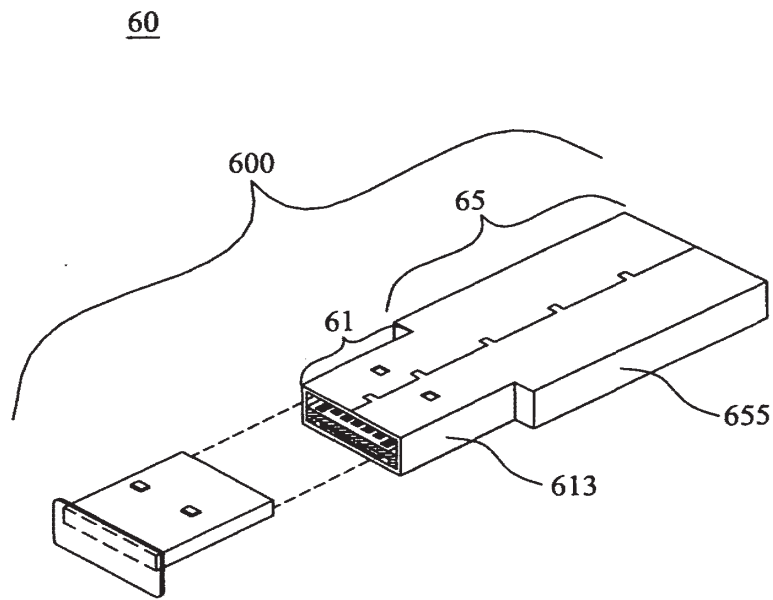

# [12] 实用新型专利说明书

[21] ZL 专利号 200420084439.9

H05K 5/00

H05K 5/02

H05K 1/11

H05K 1/02

H05K 1/18

[45] 授权公告日 2005 年 10 月 5 日

[11] 授权公告号 CN 2731910Y

[22] 申请日 2004.7.23

[21] 申请号 200420084439.9

[73] 专利权人 台均科技(深圳)有限公司

地址 518106 广东省深圳市宝安区公明镇下  
村第三工业区 23 号

[72] 设计人 施宣明

[74] 专利代理机构 北京同立钧成知识产权代理有限公司

代理人 刘芳

权利要求书 3 页 说明书 6 页 附图 3 页

[54] 实用新型名称 低厚度的设置有 USB 接口的存储装置

[57] 摘要

一种低厚度的设置有 USB 接口的存储装置, 该装置包括印刷电路板和壳体, 印刷电路板的一端一体设置有 USB 接口连接板, 该壳体包括上盖和下盖, 印刷电路板夹设在上、下盖之间, 上、下盖的形状与一体设置的 USB 接口连接板及印刷电路板形状相对应; USB 接口连接板凸设于印刷电路板之外, 与扣合的上、下盖形成 USB 接口连接部, 连接部的尺寸与 USB 电线插槽内部空间的尺寸相同。本实用新型外形小巧轻便, 存储量大, 结构简单紧凑, 实用性强, 制造成本低廉, 具有较强的安全性。

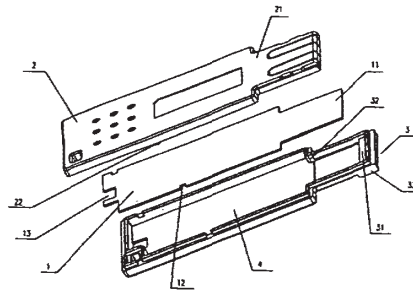

知识产权出版社出版

1、一种低厚度的设置有 USB 接口的存储装置，该装置包括印刷电路板和壳体，其特征在于：所述的印刷电路板的一端与其一体设置有 USB 接口连接板且其宽度小于印刷电路板的宽度，板整体呈“凸”字形；

5 所述的 USB 接口连接板上设有金属端子组，该金属端子组由一个以上用于与 USB 插槽内部电子信号相连接的金属片组成，该金属片与印刷电路板相连接，形成电路回路；

所述的壳体包括上盖和下盖，印刷电路板夹设在上、下盖之间，上、下盖的形状与一体设置的 USB 接口连接板及印刷电路板形状相对应；

10 所述的 USB 接口连接板凸设于印刷电路板之外，与扣合的上、下盖形成 USB 接口连接部；

所述的 USB 接口连接部的尺寸与 USB 电线插槽内部空间的尺寸相同。

2、根据权利要求 1 所述的低厚度的设置有 USB 接口的存储装置，其特征在于：所述的金属片的设置范围从 USB 接口连接板的端部直至 USB 接口连接板与印刷电路板的交界处，且金属片的长度大于等于 USB 插槽内电气接触片的长度。

3、根据权利要求 1 所述的低厚度的设置有 USB 接口的存储装置，其特征在于：所述的上盖包括一体设置的上保护盖和上保护框架，下盖包括一体设置的壳体和下保护座，其中，壳体和上保护盖将印刷电路板部分夹设在中央，下保护座和上保护框架将 USB 接口连接板夹设在中央。

4、根据权利要求 3 所述的低厚度的设置有 USB 接口的存储装置，其特征在于：所述的壳体与上保护盖的相连处的两肩部内侧开设有便于 USB 接口连接板插入的导向竖槽。

5、根据权利要求 3 所述的低厚度的设置有 USB 接口的存储装置，其特征在于：所述的上保护框架的端部横框沿框体内侧、朝壳体方向凸设一便于板体在保护框架内定位的挡片。

6、根据权利要求3所述的低厚度的设置有USB接口的存储装置，其特征在于：所述的上保护框架的端部两侧框沿框体上表面，设有方便USB接口连接部插入USB插槽内后稳定连接的凸条，其长度小于USB接口连接部凸设于壳体的长度。

5 7、根据权利要求6所述的低厚度的设置有USB接口的存储装置，其特征在于：所述的凸条的末端，在USB接口连接部插入USB插槽内后，与USB插槽两侧壁设置的夹紧弹片的夹紧点相抵紧。

8、根据权利要求1所述的低厚度的设置有USB接口的存储装置，其特征在于：所述的USB接口连接部外部还设有保护帽，套设在USB接口连接部上。

10 9、根据权利要求8所述的低厚度的设置有USB接口的存储装置，其特征在于：所述的保护帽为一抽拉块，由两侧的支撑条和底板组成，其截面形状呈“凹”字形，该抽拉块的一端设有挡板，另一端为开放端；

在底板上靠近支撑条的位置开设有两条导向槽，USB接口连接部上的凸条嵌设在导向槽内并沿导向槽滑动，USB接口连接部的端部与抽拉块的底板抵顶  
15 后，保护帽完全套设在USB接口连接部上。

10、根据权利要求9所述的低厚度的设置有USB接口的存储装置，其特征在于：所述的保护帽上的支撑条的相对两侧，向内设有定位凸齿，在下保护座的相应位置设有定位凹槽，定位凸齿和定位凹槽的设置位置和形状相对应，定位凸齿嵌设在定位凹槽内，使保护帽在USB接口连接部稳固定位。

20 11、根据权利要求10所述的低厚度的设置有USB接口的存储装置，其特征在于：所述的定位凸齿为梯形齿，两底角大小不同，沿保护帽的滑入方向，先与定位凹槽接触的一侧底角大于另一底角。

12、根据权利要求3所述的低厚度的设置有USB接口的存储装置，其特征在于：所述的壳体内壁上设有定位柱，在印刷电路板上对应开设定位孔。

25 13、根据权利要求1所述的低厚度的设置有USB接口的存储装置，其特征在于：所述的印刷电路板上设有读写显示灯。

14、根据权利要求 3 或 13 所述的低厚度的设置有 USB 接口的存储装置，其特征在于：所述的上保护框架与印刷电路板上设置读写显示灯的相应位置，设有透明的显示窗口。

5 15、根据权利要求 1 所述的低厚度的设置有 USB 接口的存储装置，其特征在于：所述的上盖和下盖均为透明材质。

16、根据权利要求 1 所述的低厚度的设置有 USB 接口的存储装置，其特征在于：所述的上盖和下盖的一顶角处开设有便携通孔。

17、根据权利要求 1 所述的低厚度的设置有 USB 接口的存储装置，其特征在于：所述的上盖和下盖的外表面上分别或同时设置有防滑图案。

10 18、根据权利要求 17 所述的低厚度的设置有 USB 接口的存储装置，其特征在于：所述的防滑图案由外表面上的凸起或凹坑组成。

19、根据权利要求 3 所述的低厚度的设置有 USB 接口的存储装置，其特征在于：所述的下保护座的外表面设有导向槽，其设置位置与 USB 插槽下表面夹紧弹片的设置位置相对应。



## 低厚度的设置有 USB 接口的存储装置

### 技术领域

- 5           本实用新型涉及一种带有 USB 接口连接部的存储装置，尤其是一种低厚度的设置有 USB 接口的存储装置。

### 背景技术

- 随着电子技术的发展，存储装置的种类越来越多，储存容量也越来越大。  
10       而存储装置中所储存的资料，通常需要与电脑之间进行资料转换传输之后，再进一步处理。存储装置与电脑之间最常用的资料转换传输方式，是利用 USB 接口与插槽之间的插接实现的。直接将存储装置上的 USB 接口插入电脑主机端的 USB 插槽中便可以进行资料传输了。

- 而现有的利用 USB 接口与插槽与电脑进行数据转换传输的存储装置，在容  
15       量大的同时，体积也不够小巧。如何缩小 USB 资料存储装置的尺寸，使其在保证使用功能的前提下，更加方便、轻巧，降低制造成本且保证其使用安全性，是亟待解决的问题。

### 实用新型内容

- 20       本实用新型所要解决的技术问题在于，针对现有技术的不足，提供一种低厚度的设置有 USB 接口的存储装置，其外形小巧轻便，存储量大，结构简单紧凑，实用性强，制造成本低廉，具有较强的安全性能。

          本实用新型所要解决的技术问题是通过如下技术方案实现的：

- 一种低厚度的设置有 USB 接口的存储装置，该装置包括印刷电路板和壳体，  
25       印刷电路板的一端与其一体设置有 USB 接口连接板且其宽度小于印刷电路板的宽度，板整体呈“凸”字形；

          USB 接口连接板上设有金属端子组，该金属端子组由一个以上用于与 USB

插槽内部电子信号相连接的金属片组成，该金属片与印刷电路板相连接，形成电路回路；

壳体包括上盖和下盖，印刷电路板夹设在上、下盖之间，上、下盖的形状与一体设置的 USB 接口连接板及印刷电路板形状相对应；

- 5 USB 接口连接板凸设于印刷电路板之外，与扣合的上、下盖形成 USB 接口连接部；

USB 接口连接部的尺寸与 USB 电线插槽内部空间的尺寸相同。

- 10 为了使该存储装置的 USB 接口与 USB 插槽连接稳定，金属片的设置范围从 USB 接口连接板的端部直至 USB 接口连接板与印刷电路板的交界处，且金属片的长度大于等于 USB 插槽内电气接触片的长度。

上盖包括一体设置的上保护盖和上保护框架，下盖包括一体设置的壳体和下保护座，其中，壳体和上保护盖将印刷电路板部分夹设在中央，下保护座和上保护框架将 USB 接口连接板夹设在中央。

- 15 为了使 USB 接口连接部插入 USB 插槽内后能够稳定连接，在上保护框架的端部两侧框沿框体上表面，设有凸条。该凸条的长度小于 USB 接口连接部凸设于壳体的长度，当 USB 接口连接部插入 USB 插槽内后，凸条的末端，与 USB 插槽两侧壁设置的夹紧弹片的夹紧点相抵触，以保证连接稳定。

为有效保护 USB 接口，增强其使用安全性，在 USB 接口连接部外部还设有保护帽，套设在 USB 接口连接部上。

- 20 保护帽为一抽拉块，由两侧的支撑条和底板组成，其截面形状呈“凹”字形，该抽拉块的一端设有挡板，另一端为开放端；

在底板上靠近支撑条的位置开设有两条导向槽，USB 接口连接部上的凸条嵌设在导向槽内并沿导向槽滑动，USB 接口连接部的端部与抽拉块的底板抵顶后，保护帽完全套设在 USB 接口连接部上。

- 25 综上所述，本实用新型所提供的这种带有 USB 介面连接装置的低厚度存储装置，外形小巧轻便，结构简单紧凑，制造成本低廉；其抽拉块式的 USB 接

口连接部保护帽，使该存储装置具有较强的安全性能。

### 附图说明

图 1 为本实用新型的分解示意图；

5 图 2 为本实用新型不带保护帽的整体结构示意图；

图 3 为本实用新型带有保护帽的分解示意图；

图 4 为本实用新型带有保护帽的正面整体结构示意图；

图 5 为本实用新型定位凸齿和定位凹槽的结构关系示意图；

图 6 为本实用新型带有保护帽的背面整体结构示意图。

10

### 具体实施方式

下面结合附图和具体实施例对本实用新型的技术方案进行详细地说明。

实施例一：

如图 1 所示，为本实用新型的分解示意图。从图中可知，本实用新型印刷  
15 电路板 1 和壳体，印刷电路板 1 的一端与其一体设置有 USB 接口连接板 11 且其  
宽度小于印刷电路板 1 的宽度，板整体呈“凸”字形；USB 接口连接板 11 上设  
有金属端子组，该金属端子组由一个以上用于与 USB 插槽内部电子信号相连接  
的金属片组成，该金属片与印刷电路板 1 相连接，形成电路回路；壳体包括上  
盖和下盖，印刷电路板 1 夹设在上、下盖之间，上、下盖的形状与一体设置的  
20 USB 接口连接板及印刷电路板形状相对应；USB 接口连接板 11 凸设于印刷电  
路板 1 之外，与扣合的上、下盖形成 USB 接口连接部 300；USB 接口连接部 300  
的尺寸与 USB 电线插槽内部空间的尺寸相同。

上盖包括一体设置的上保护盖 4 和上保护框架 3，下盖包括一体设置的壳  
体 2 和下保护座 21，其中，壳体 2 和上保护盖 4 将印刷电路板 1 部分夹设在中央，  
25 下保护座 21 和上保护框架 3 将 USB 接口连接板 11 夹设在中央。

为了使该存储装置的 USB 接口与 USB 插槽连接稳定，金属片的设置范围从

USB 接口连接板 11 的端部直至 USB 接口连接板 11 与印刷电路板 1 的交界处，且金属片的长度大于等于 USB 插槽内电气接触片的长度。这种设计使 USB 接口插入 USB 插槽后，金属片与 USB 插槽内的电气接触片完全、充分接触。克服了现有储存器的 USB 接口插入插槽内，极易接触不良的弊端。

5           USB 接口连接板 11 凸设于壳体 2 之外，其两侧面设有保护架将 USB 接口连接板 11 夹设在其中，形成 USB 接口连接部。保护架包括上保护框架 3 和下保护座 21，为了使 USB 接口连接板 11 上的金属端子组外露，以便于插拔连接，上保护框架 3 的中部是镂空的，该镂空位置刚好与金属端子组相对应。上保护框架 3 与下保护座 21 彼此扣设在一起，将 USB 接口连接板夹设在中间。

10           USB 接口连接板 11 夹设在彼此扣合在一起的下保护座 21 和上保护框架 3 中央，形成 USB 接口连接部 300，该 USB 接口连接部 300 的尺寸与 USB 电线插槽内部空间的尺寸完全吻合。其结构如图 2 所示。

结合图 1、图 2 所示，本实用新型储存器的装配过程是这样的：

15           首先：将印刷电路板 1 端部的 USB 接口连接板 11 沿上保护框架 3 与上保护盖 4 的交界线插入，以交界线为轴将板体翻转，使 USB 接口连接板 11 的板体端部刚好卡在上保护框架 3 的端部横框沿框体内侧、朝壳体方向凸设的挡片 31 下方，以便于板体在保护框架 3 内定位。为了使 USB 接口连接板 11 能够顺利的插入，在上保护框架 3 与上保护盖 4 相连的两肩部内侧开设有导向竖槽 32。

20           其次：将一体设置的下保护座 21 和壳体 2 扣设在上已经安装好印刷电路板 1 的上保护框架 3 上，并将其用胶粘住，形成如图 2 所示的储存器。

为了方便印刷电路板 1 的定位，如图 1 所示，在壳体 2 内壁上设有定位柱 22，在印刷电路板 1 上对应开设定位孔 12，一体设置的下保护座 21 和壳体 2 扣设在上保护框架 3 上时，定位柱 22 嵌设在定位孔 12 中，印刷电路板 1 就不容易发生错位和变形。

25           为了使 USB 接口连接部插入 USB 插槽内后能够稳定连接，在上保护框架 3 的端部两侧框沿框体上表面，设有的凸条 33，其长度小于 USB 接口连接部凸设

于壳体的长度，当 USB 接口连接部插入 USB 插槽内后，凸条 33 的末端，正好与 USB 插槽两侧壁设置的夹紧弹片的夹紧点相抵紧，使两者稳定连接。

如图 3 所示，为本实用新型带有保护帽的分解示意图。从图中可知，为了有效保护 USB 接口，还设有保护帽 5，该保护帽 5 套设在 USB 接口连接部 300 上。保护帽 5 为一抽拉块，由两侧的支撑条 51 和底板 52 组成，其截面形状呈“凹”字形，该抽拉块的一端设有挡板 53，另一端为开放端。

如图 4 所示，为本实用新型带有保护帽的整体结构示意图。参见图 4 并结合图 3 可知，在保护帽 5 的底板 52 上靠近支撑条 51 的位置开设有两条导向槽 54，USB 接口连接部 300 上的凸条 33 嵌设在导向槽 54 内。将保护帽 5 套设在 USB 接口连接部 300 上的时候，凸条 33 沿导向槽 54 滑动，USB 接口连接部的端部与保护帽 5 的挡板 53 抵顶后，保护帽 5 完全套设在 USB 接口连接部 300 上。

如图 5 所示，为本实用新型定位凸齿和定位凹槽的结构关系示意图。从图中可知，在保护帽 5 上的支撑条 51 的相对两侧，向内设有定位凸齿 52，在下保护座 3 的相应位置设有定位凹槽 34，定位凸齿 52 和定位凹槽 34 的设置位置和形状相对应，定位凸齿 52 嵌设在定位凹槽 34 内，使保护帽 5 在 USB 接口连接部 300 稳固定位，其结构关系如图 6 所示。

如图 5 所示，定位凸齿 52 为梯形齿，两底角大小不同，沿保护帽 5 的滑入方向，先与定位凹槽 34 接触的一侧底角大于另一底角，以便于保护帽 5 的滑入和定位。

另外，当把储存器插入电脑的 USB 插槽内进行数据传输时，为了方便操作者观察，在印刷电路板上 11 设有读写显示灯，该显示灯的设置位置在如图 1 所示的开口 13 处。在上保护盖 4 与印刷电路板 1 上设置读写显示灯的相应位置，设有透明的显示窗口（图中未示出）。

为了更加美观、实用，壳体 2 和上保护盖 4 均为透明材质。

如图 6 所示，并结合图 1，在储存器的一顶角处开设有便携通孔 6。

壳体 2 或上保护盖 4 的外表面上分别或同时设置有防滑图案 23, 该防滑图案由设置在外表面上的凸起或凹坑组成。

另外, 在下保护座的外表面还设有导向槽 35, 其设置位置与 USB 插槽下表面夹紧弹片的设置位置相对应。

5

最后需要说明的是: 以上实施例仅用以说明本实用新型的技术方案而非限制, 尽管参照较佳实施例对本实用新型进行了详细说明, 本领域的普通技术人员应当理解, 可以对本实用新型的技术方案进行修改或者等同替换, 而未脱离本实用新型技术方案的精神和范围, 其均应涵盖在本实用新型的权

10 利要求范围当中。



图 1



图 2

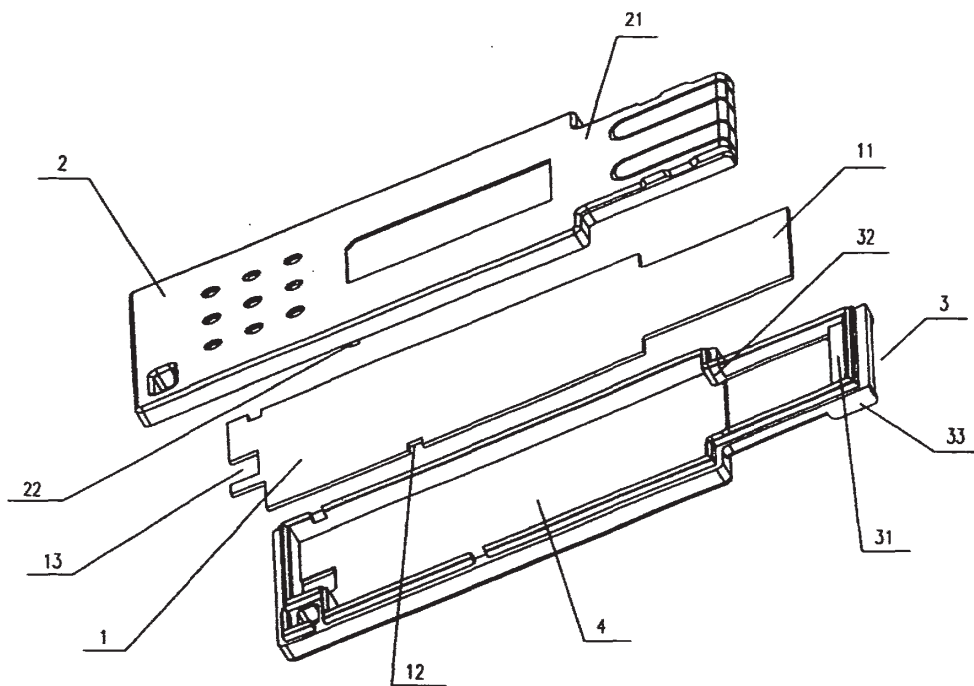

图 3

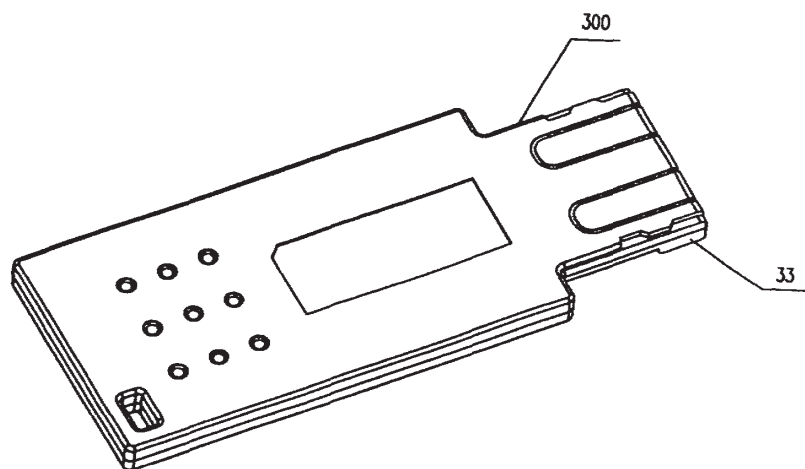

图 4



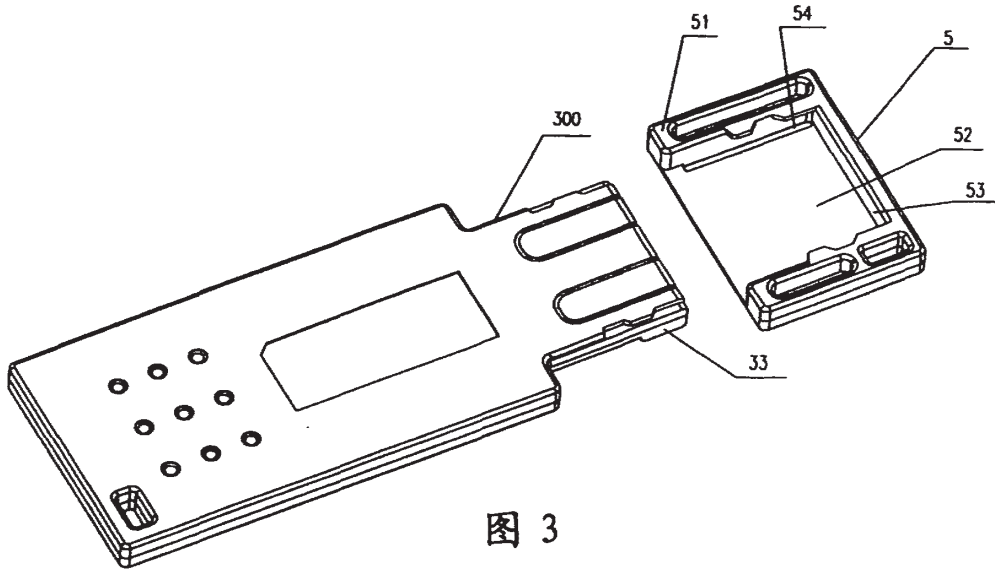

图 5

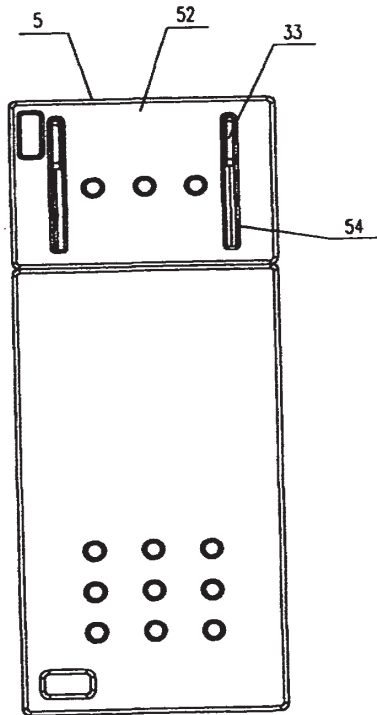

图 6

[19]中华人民共和国专利局

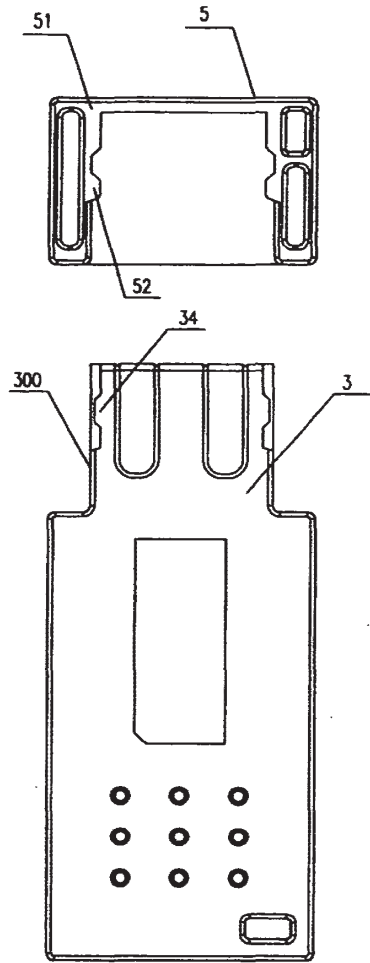
[11] 授权公告号 CN 2142631Y

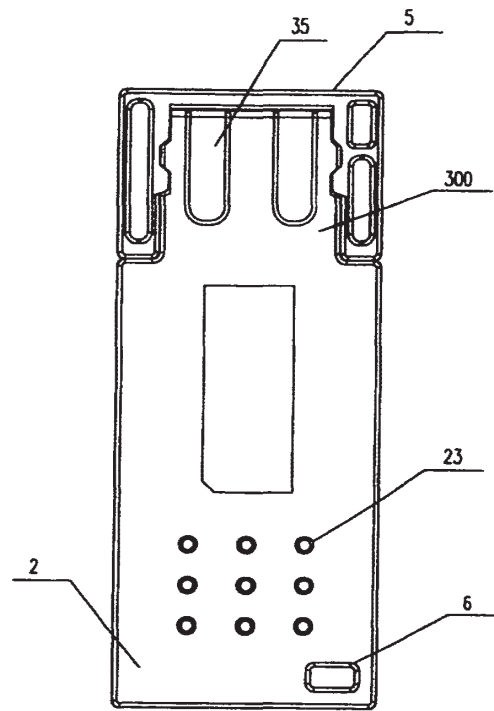

## [12]实用新型专利说明书

[21] ZL 专利号 92243717.3

[51]Int.Cl<sup>5</sup>

H05K 7/12

[45]授权公告日 1993年9月22日

[22]申请日 92.12.14 [24]颁证日 93.7.10

[73]专利权人 黄进坤

地址 100036北京市海淀区太平路22院11楼  
西门一楼东

[72]设计人 黄进坤

[21]申请号 92243717.3

说明书页数: 2 附图页数: 3

[54]实用新型名称 线路板固定支柱

[57]摘要

本实用新型为一种线路板固定支柱,主要是将电源供应器箱等箱体上固定PV板的螺孔柱加以改进设计,以冲压方式一次加工成型呈一凸出的支柱,支柱顶端的圆孔上冲压一断叉,使圆孔呈一具螺旋状的螺孔,以便于螺钉的固定,整体上具有降低成本、强度高、生产速度快等效能。

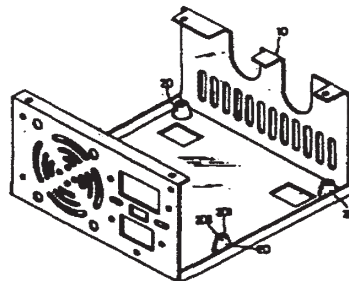

<S>  
<S>

(BJ)第 1452 号

## 权 利 要 求 书

---

1、一种线路板固定支柱，其特征在于：在箱、壳体上以冲压方式形成凸出的支柱，支柱顶端为一圆孔，圆孔内径呈与螺钉沟槽形状相符凸出的顶部，并在圆孔外缘冲压一断叉，断叉的错开可使圆孔呈一螺旋状，借此支柱上的圆孔提供与螺钉配合的螺孔功能，以便于固定PC板。

## 说 明 书

### 线路板固定支柱

本实用新型涉及一种线路板(PC板)固定支柱。

一般电源供应器箱(A)(如附图1所示)和电脑壳体等的箱、壳内,均设有固定PC板的螺孔柱(B),常用的结构为先将螺孔柱(B)车好螺孔后,再铆接固定在箱、壳内,然后用螺钉与螺孔柱的螺纹来固定PC板。这种常用的结构由于需经螺孔车制、螺孔柱铆合等多次加工,费时费力,影响生产速度,无形中增加大量制造成本。再者螺孔柱铆合的强度也不佳,螺孔柱铆合垂直度亦容易产生偏差,因此产品质量很难达到较佳水平。

本实用新型的目的在于避免上述现有技术的不足之处,而提供一种PC板固定支柱。

本实用新型的目的可以通过以下措施来实现,在箱、壳体上以冲压方式形成凸出的支柱,支柱的顶端为一圆孔,圆孔内径呈与螺纹沟槽形状相符凸出的顶部,并于圆孔外缘冲压一断叉,断叉的错开可使圆孔呈一螺旋状,借此支柱上的圆孔具有与螺钉配合的螺孔功能,以便固定PC板。

附图的图面说明如下。

图1为常用的PC板固定结构的立体视图。

图2为本实用新型实施例的立体视图。

图3为本实用新型实施例支柱的平面剖视图。

本实用新型下面将结合附图实施例做进一步说明,在电源供应器箱(A)等箱、壳体上,以直接冲压方式形成一凸出的支柱(20),作为固定PC板的螺孔柱,(请同时参阅附图3),该支柱(20)的顶端为一圆孔(201),圆孔(201)内径呈一断面与螺纹的沟槽形状相符凸出的顶部(202),并于圆孔(201)

外缘同时冲压一断叉(203)，借断叉(203)的错开使圆孔(201)呈一螺旋状，即如同螺孔的功能，借此支柱(20)上的圆孔(201)即可具有用螺钉紧固PC板的功能。

由于本实用新型的支柱采用一体成型一次加工完成，因此生产速度极为快速，生产成本亦低廉，并且支柱成型位置精确，垂直度及强度较佳，与螺钉配合时锁紧力亦佳。在应用方面，本实用新型除可取代螺孔柱外，亦可应用于在电源供应器箱、电脑壳体等的螺孔上，以作为与螺钉配合固定之用。

说明书附图

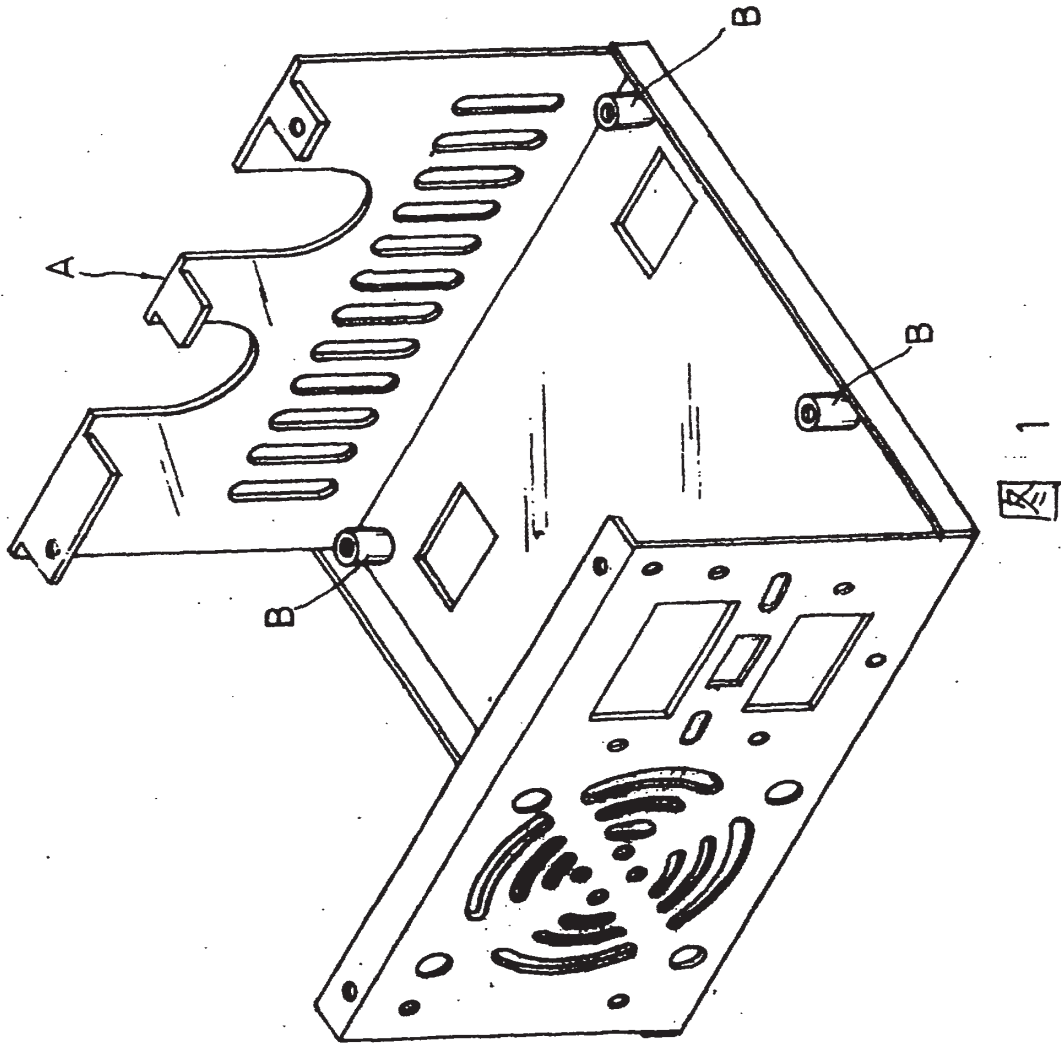



图 2



图 3

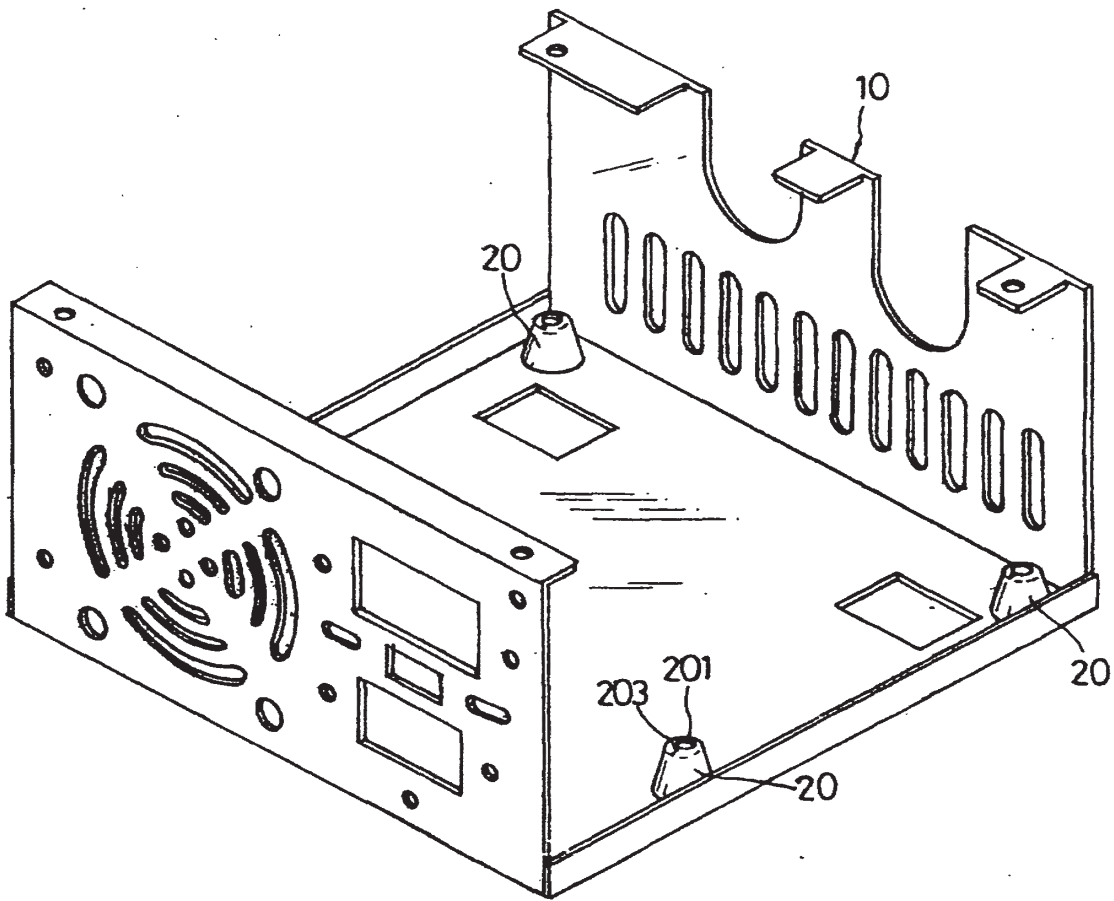

(19) 日本国特許庁(JP)

(12) 登録実用新案公報(U)

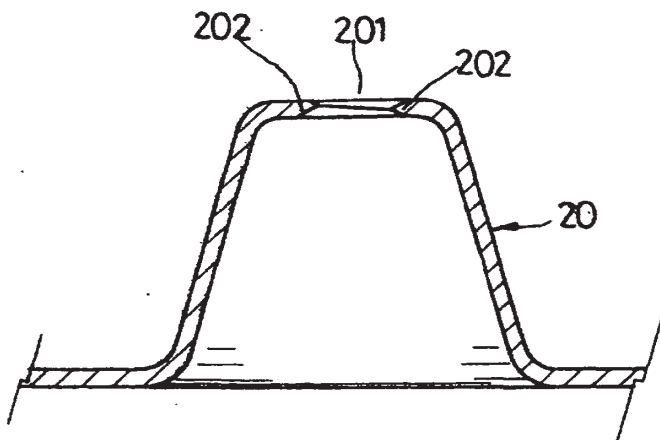
(11) 実用新案登録番号

実用新案登録第3099411号  
(U3099411)

(45) 発行日 平成16年4月8日(2004.4.8)

(24) 登録日 平成15年11月12日(2003.11.12)

(51) Int. Cl. <sup>7</sup>	F 1
HO2H 9/04	HO2H 9/04 A
HO1R 13/648	HO1R 13/648
HO2H 7/20	HO2H 7/20 Z

評価書の請求 未請求 請求項の数 2 O L (全 6 頁)

(21) 出願番号 実願2003-270202(U2003-270202)  
(22) 出願日 平成15年7月23日(2003.7.23)

(73) 実用新案権者 502183289  
水口 寛志  
東京都渋谷区円山町21-3号  
(74) 代理人 100084984  
弁理士 澤野 勝文  
(74) 代理人 100094123  
弁理士 川尻 明  
(72) 考案者 水口 寛志  
東京都渋谷区円山町21-3号

(54) 【考案の名称】 USBプラグ及びUSBケーブル

(57) 【要約】

【課題】 コンピュータのUSB接続用ターミナルにサージ防護回路が設けられていない場合であっても、コンピュータ及びこれに接続された周辺機器に対して外来サージ電圧による悪影響が及ぶことを防止する。

【解決手段】 角型シールドフレーム5S内に一對の電源用プラグ端子5A、5B及び一對の信号用プラグ端子5C、5Dが設けられたUSBプラグ3のプラグハウジング7内に、一つの電子チップ10に組み込まれた四つのサージ吸収ツェナーダイオード9A~9Dの各カソード端子12を各プラグ端子5A~5Dに個別に接続すると共に、各アノード端子14を一括してシールドフレーム5Sに接続したサージ防護回路Cを設けた。

【選択図】 図1

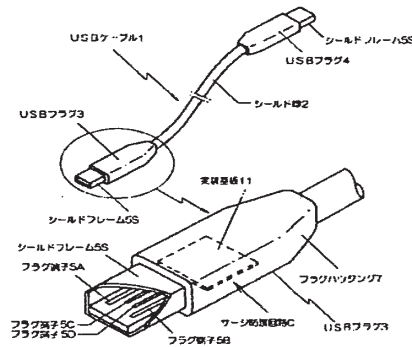

## 【実用新案登録請求の範囲】

## 【請求項1】

USBレセプタクルに挿し込まれる角型シールドフレーム内に、一对の電源用プラグ端子及び一对の信号用プラグ端子が設けられたUSBプラグにおいて、

一つの電子チップに組み込まれた四つのサージ吸収ツェナーダイオードの各カソード端子を前記各プラグ端子に個別に接続すると共に、各アノード端子を一括してシールドフレームに接続したサージ防護回路が、プラグハウジング内に形成されたことを特徴とするUSBプラグ。

## 【請求項2】

USBレセプタクルに挿し込まれる角型シールドフレーム内に、一对の電源用プラグ端子及び一对の信号用プラグ端子を設けたUSBプラグが、少なくとも四本の芯線を有するシールド線の一端側に取り付けられてなるUSBケーブルにおいて、

一つの電子チップに組み込まれた四つのサージ吸収ツェナーダイオードの各カソード端子を前記各プラグ端子に個別に接続すると共に、各アノード端子を一括してシールドフレームに接続したサージ防護回路が、前記USBプラグのプラグハウジング内に形成されたことを特徴とするUSBケーブル。

10

## 【考案の詳細な説明】

## 【技術分野】

## 【0001】

本考案は、パソコンとその周辺機器をUSB規格のシリアルインターフェイスにより接続するためのUSBプラグ及びUSBケーブルに関する。

20

## 【背景技術】

## 【0002】

コンピュータは、必要に応じて、プリンタ、スキャナ、外部メモリドライブ、通信機器等の周辺機器を接続して使用することができ、その接続する規格の一つにUSBがある。

USBは、一对の信号用プラグ端子の他に一对の電源用プラグ端子とを備えている。

したがって、コンピュータと周辺機器とをUSBケーブルで接続すれば、コンピュータから周辺機器に対して電源電力が供給され、別途給電線を接続するまでもなくその周辺機器を使用することができるというメリットを有しており、多くのコンピュータにはUSB規格の接続用ターミナルが標準装備されている。

30

## 【0003】

ところで、USBプラグは、USBレセプタクルに挿し込んだときに、まず、シールドフレームがレセプタクル側のシールドに接触してから、各プラグ端子がレセプタクル側の端子に接続する構造になっている。

この場合、冬季に起こりやすい現象であるが、人体に大量の静電気が帯電した状態でプラグを持つと、その静電気がプラグやケーブル内に帯電され、この状態で、プラグをレセプタクルに挿し込むと、シールド同士の接触だけでは完全には静電気が放電されず、まだ静電気が残った状態でプラグ端子が接続されるため、機器側に有害な外来サージ電圧を与える事になる。

40

また、このようなUSB接続用ターミナルに周辺機器を接続して使用しているときに、落雷などによる有害な外来サージ電圧がUSBケーブルの芯線及びプラグ端子を介して機器内部に侵入することがある。

そして、この外来サージ電圧がコンピュータや周辺機器の内部回路、記憶装置などの弱電素子を破壊したり、これらを誤動作させたり、さらには記憶されたデータを消滅させるおそれがある。

このため、従来は、コンピュータの接続用ターミナルに、バリスタ、アレスタやツェナーダイオードからなるサージ防護回路を設けているのが一般的である。

## 【特許文献1】特開平8-251812号公報

## 【0004】

50

しかしながら、ノート型パソコン、携帯電話、PDA等の小型携帯機器や、廉価なパソコンには、スペース的な理由あるいはコスト的な理由により、接続用ターミナル内にサージ防護回路が設けられていないものもある。

【0005】

特に、USB規格はコンピュータ側から電源の供給を受けるようになっているので、その給電ラインを介して外来サージ電圧による大電圧が直接内部回路に印加されやすく、悪影響を受けやすい。

【考案の開示】

【考案が解決しようとする課題】

【0006】

そこで本考案が解決しようとする課題は、コンピュータのUSB接続用ターミナルにサージ防護回路が設けられていなくても、コンピュータ及びこれに接続された周辺機器に対して外来サージ電圧による悪影響が及ぶことを防止することにある。

【課題を解決するための手段】

【0007】

この課題を解決するために、請求項1の考案は、USBレセプタクルに挿し込まれる角型シールドフレーム内に、一对の電源用プラグ端子及び一对の信号用プラグ端子が設けられたUSBプラグにおいて、一つの電子チップに組み込まれた四つのサージ吸収ツェナーダイオードの各カソード端子を前記各プラグ端子に個別に接続すると共に、各アノード端子を一括してシールドフレームに接続したサージ防護回路が、プラグハウジング内に形成されたことを特徴としている。

また、請求項2の考案は、USBレセプタクルに挿し込まれる角型シールドフレーム内に、一对の電源用プラグ端子及び一对の信号用プラグ端子を設けたUSBプラグが、少なくとも四本の芯線を有するシールド線の一端側に取り付けられてなるUSBケーブルにおいて、一つの電子チップに組み込まれた四つのサージ吸収ツェナーダイオードの各カソード端子を前記各プラグ端子に個別に接続すると共に、各アノード端子を一括してシールドフレームに接続したサージ防護回路が、前記USBプラグのプラグハウジング内に形成されたことを特徴としている。

【考案の効果】

【0008】

本考案のUSBプラグによれば、プラグハウジング内にサージ防護回路が形成されている。

サージ防護回路は、一つの電子チップに四つのサージ吸収ツェナーダイオードを組み込んで、そのカソード端子がUSBプラグの各プラグ端子の夫々に個別に接続され、アノード端子が一括してシールドフレームに接続されている。

したがって、このUSBプラグをUSBケーブルとなる四芯シールド線の先端に取り付けるだけで、各芯線とシールド間にサージ吸収ツェナーダイオードが接続されることとなる。

【0009】

このUSBケーブルを用いてコンピュータとその周辺機器を接続すると、USBケーブル自体にサージ防護回路が形成されているので、人体に帯電した静電気の放電や落雷等により瞬間的に大電圧が印加されることがあっても、そのような外来サージ電圧を、各芯線とシールド間に接続されているツェナーを通してシールドに逃がすことができる。

すなわち、帯電したケーブルを接続するとき外来サージ電圧が生じたり、ケーブルを接続して使用している間に外来サージ電圧が作用することがあっても、その外来サージ電圧が確実にシールドに逃がされ、芯線を介してコンピュータ及びその周辺機器に侵入することを未然に防止することができる。

したがって、機器側の接続用ターミナル内部にサージ防護回路が形成されていない場合でも、外来サージ電圧による悪影響を受けることがないという大変優れた効果を有する。

【考案を実施するための最良の形態】

10

20

30

40

50

## 【0010】

本例は、コンピュータのUSB接続用ターミナル内部にサージ防護回路が形成されていない場合であって、コンピュータ及びこれに接続された周辺機器に対して外来サージ電圧による悪影響が及ぶことを防止するという目的を、USBプラグ内にサージ防護回路を形成することにより実現した。

## 【0011】

図1は本考案に係るUSBプラグ及びUSBケーブルを示す説明図、図2はサージ防護回路の実装基板を示す説明図、図3はその回路図である。

## 【0012】

図1に示すUSBケーブル1は、シールド線2の両端にUSBプラグ3及び4が取り付けられてなる。 10

USBプラグ3及び4は、コンピュータ又は周辺機器に形成された接続用ターミナルとなるUSBレセプタクル（図示せず）に挿し込まれる断面長方形の筒型シールドフレーム5S内に、一对の電源用プラグ端子5A、5B及び一对の信号用プラグ端子5C、5Dが配されている。

そして、各USBプラグ3及び4の対応するプラグ端子5A～5D同士が、シールド線2の4本の芯線6A～6Dを介して接続されると共に、シールドフレーム5S同士がシールド線2のシールド6Sを介して接続されている。

## 【0013】

そして、少なくとも一方のUSBプラグ3のプラグハウジング7内には、サージ防護回路Cが配されている。 20

このサージ防護回路Cは、図2に示すように、外形サイズ縦×横×厚さ＝1.6mm×1.6mm×0.6mm程度のパッケージ8内に四つのサージ吸収ツェナーダイオード9A～9Dを組み込んだ一つの電子チップ10を実装基板11に装着することにより形成されている。

このツェナーダイオード9A～9Dは、ツェナー電圧6.47～7.00V、容量25pF以下、静電サージ耐量25kV以上（IEC61000-4-2接触放電時）という高サージ耐量特性を有したものが用いられている。

## 【0014】

電子チップ10には、各ツェナーダイオード9A～9Dのカソード端子12に個別に導通される四つの電極端子13A～13Dと、アノード端子14に一括して導通される一つの電極端子13Sが形成されている。 30

## 【0015】

また、実装基板11には、カソード端子12に導通されている各電極端子13A～13Dを、夫々のプラグ端子5A～5D及びこれに対応する芯線6A～6Dに個別に接続されるランド15A～15D及び16A～16Dが形成されると共に、アノード端子14に導通される電極端子13Sをシールドフレーム5S及びシールド線シールド6Sに接続されるランド15S及び16Sが形成されてなる。

## 【0016】

これにより、図3に示すように、少なくとも一方のUSBプラグ3のプラグ端子5A～5D及びシールドフレーム5Sは、プラグハウジング7に内蔵された実装基板11を介して、シールド線2の各芯線6A～6D及びシールド6Sに接続される。 40

また、USBケーブル1の各芯線5A～5Dとシールド5Sの間に、サージ防護回路Cを構成するツェナーダイオード9A～9Dが介装されることとなり、これにより、各芯線5A～5Dにツェナー電圧以上の大電圧が瞬間的に作用した場合でも、その電圧をシールドに逃がすことができ、外来サージ電圧による悪影響を防止することができる。

## 【0017】

以上が本考案の一構成例であって、次にその作用を説明する。

USBケーブル1を用いて、コンピュータに、プリンタ、スキャナ、外部メモリドライブ、通信機器等の周辺機器を接続する。 50

USBケーブル1の各芯線6A～6Dとシールド6Sの間に、サージ防護回路Cを構成するツェナーダイオード9A～9Dが接続されているので、コンピュータと周辺機器とをUSBケーブル1で接続することにより、その接続用ターミナルにサージ防護回路を形成した場合と電氣的に等価となる。

したがって、人体に帯電した静電気の放電や落雷等により瞬間的に大電圧が印加されることがあっても、そのような有害な外来サージ電圧が、各芯線6A～6Dとシールド6S間に接続されているツェナーダイオード9A～9Dを通してシールド6Sに逃がされる。

すなわち、帯電したケーブル1を接続するとき外来サージ電圧が生じたり、ケーブル1を接続して使用している間に外来サージ電圧が作用することがあっても、その外来サージ電圧が確実にシールド6Sに逃がされ、芯線6A～6Dを介してコンピュータ及びその周辺機器に侵入することを未然に防止することができる。

10

このように、USBケーブル1に取り付けられたUSBプラグ3内にサージ防護回路Cが形成されているので、機器側の接続用ターミナル内部にサージ防護回路が形成されていない場合でも、有害な外来サージ電圧が確実にシールド6Sに逃がされ、コンピュータや周辺機器が外来サージ電圧による悪影響を受けないという大変優れた効果を有する。

【産業上の利用可能性】

【0018】

サージ防護回路をUSBプラグ内に配したので、機器側のUSB接続用ターミナルにサージ防護回路が設けられていない場合であっても、そのUSBケーブルを用いてコンピュータと周辺機器を接続することにより、外来サージ電圧が機器側に侵入することを未然に防止するという用途に適用できる。

20

【図面の簡単な説明】

【0019】

【図1】本考案に係るUSBプラグ及びUSBケーブルを示す説明図。

【図2】サージ防護回路の実装基板を示す説明図。

【図3】その回路図。

【符号の説明】

【0020】

- 1 …… USBケーブル
- 2 …… シールド線
- 3、4 …… USBプラグ
- 5A～5D …… プラグ端子
- 5S …… シールドフレーム
- 6A～6D …… 芯線
- 6S …… シールド
- 7 …… プラグハウジング
- C …… サージ防護回路
- 8 …… パッケージ
- 9A～9D …… サージ吸収ツェナーダイオード
- 10 …… 電子チップ
- 11 …… 実装基板
- 12 …… カソード端子
- 14 …… アノード端子

30

40



## PATENT ABSTRACTS OF JAPAN

(11)Publication number : 2004-103907

(43)Date of publication of application : 02.04.2004

(51)Int.Cl. H05K 7/14  
B41J 29/02

(21)Application number : 2002-265176

(71)Applicant : SEIKO EPSON CORP

(22)Date of filing : 11.09.2002

(72)Inventor : NISHIWAKE KAZUHIRO

### (54) POSITIONING STRUCTURE OF CIRCUIT BOARD

#### (57)Abstract:

**PROBLEM TO BE SOLVED:** To provide a positioning structure of a circuit board wherein restriction of component arrangement is eliminated and miniaturization of the circuit board is enabled.

**SOLUTION:** In a metal plate 2, a positioning part 11 for positioning a circuit board 1 is formed by spinning. The positioning part 11 is formed almost in a conical which is protruded from the metal plate 2 on beveled of obtuse angle. An engagement part 12 is formed on a tip part of the positioning part 11. The engagement part 12 is formed so as to have the same shape as a hole 1e for positioning which is formed on the circuit board 1, and so as to be a little smaller than the hole 1e. As a result, by arranging the circuit board 1 on the hole 1e, the engagement part 12 is engaged with the hole 1e, and the circuit board 1 is positioned in a surface direction. A retaining surface 13 is formed on a proximal end portion of the engagement part 12 and retains the circuit board 1 from a back side of the circuit board 1 when the engagement part 12 is engaged with the circuit board 1, so that positioning of the circuit board 1 is enabled in a direction perpendicular to a surface of the circuit board 1.

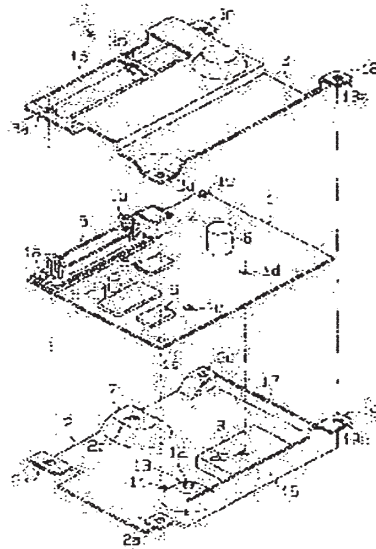

(19) 日本国特許庁(JP)

(12) 公開特許公報(A)

(11) 特許出願公開番号

特開2004-103907

(P2004-103907A)

(43) 公開日 平成16年4月2日(2004.4.2)

(51) Int. Cl.<sup>7</sup>

H05K 7/14

B41J 29/02

F I

H05K 7/14

B41J 29/02

F

テーマコード(参考)

2C061

5E348

審査請求 未請求 請求項の数 4 O L (全 8 頁)

(21) 出願番号 特願2002-265176 (P2002-265176)  
 (22) 出願日 平成14年9月11日(2002.9.11)

(71) 出願人 000002369  
 セイコーエプソン株式会社  
 東京都新宿区西新宿2丁目4番1号  
 (74) 代理人 100068755  
 弁理士 思田 博宣  
 (74) 代理人 100105957  
 弁理士 思田 誠  
 (72) 発明者 西分 一宏  
 長野県諏訪市大和3丁目3番5号 セイコーエプソン 株式会社内  
 Fターム(参考) 2C061 BB35 DD07  
 5E348 AA32 AA40

(54) 【発明の名称】 回路基板の位置決め構造

(57) 【要約】

【課題】 部品配置に制限をなくし、回路基板の小型化が可能な回路基板の位置決め構造を提供する。

【解決手段】 金属板2には、回路基板1の位置決めのための位置決め部11が絞り加工により形成されている。位置決め部11は、金属板2から鈍角の斜面で突出した略円錐状に形成されている。位置決め部11の先端部には係合部12が形成されている。係合部12は、回路基板1に形成される位置決め用の孔1cと同形状で、若干小さく形成されている。このため、位置決め用の孔1eに回路基板1を置くことで、係合部12が位置決め用の孔1eと係合し、回路基板1が面方向において位置決めされる。係合部12の基端部には支持面13が形成されている。支持面13は、係合部12と回路基板1が係合する際に、回路基板1の裏側から回路基板1を支えることで回路基板1の面と垂直な方向において回路基板1の位置決めをすることが可能である。

【選択図】 図1

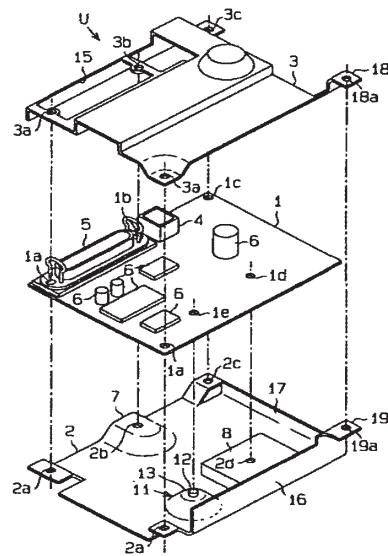



## 【特許請求の範囲】

## 【請求項 1】

回路基板の実装面側とは反対面側に設けられる防火エンクロージャとしての金属板に対して回路基板の固定位置を決めるための回路基板の位置決め構造であって、前記回路基板は位置決め用の孔を有し、前記金属板を絞って突出形成された位置決め部が前記孔と係合することで位置決めをすることを特徴とする回路基板の位置決め構造。

## 【請求項 2】

前記位置決め部は前記金属板から錘状に突出するとともにその先端部に前記回路基板の孔と係合する係合部を有し、該係合部が前記孔と係合することで前記回路基板はその面方向において位置決めされるようになっており、該位置決め部の錘状に突出する斜面は該金属板の面方向に対して鈍角をなしていることを特徴とする請求項 1 に記載の回路基板の位置決め構造。

10

## 【請求項 3】

前記位置決め部は、前記孔が前記係合部に係合された状態で前記回路基板を面方向と垂直な方向に位置決めする支持面を有することを特徴とする請求項 1 又は請求項 2 に記載の回路基板の位置決め構造。

## 【請求項 4】

前記位置決め部は、金属板を絞り加工することにより形成されることを特徴とする請求項 1～請求項 3 のいずれか一項に記載の回路基板の位置決め構造。

## 【発明の詳細な説明】

20

## 【0001】

## 【発明の属する技術分野】

本発明は、回路基板の位置決め構造に関するものである。

## 【0002】

## 【従来の技術】

従来、回路基板の実装面側とその反対面側とに防火エンクロージャとしての金属板が設けられる場合がある。例えばプリンタの場合、回路基板とその取り付け先であるメカフレーム（金属製フレーム）又は樹脂ケースとの間に防火エンクロージャとして金属板を介在させていた。回路基板は金属板を介在させた状態で通常ネジ等を用いて金属製フレーム又は樹脂ケースに組付けられるが、この際、回路基板を金属板に位置決めできるように位置決め用のボスを形成することが通常行われていた。位置決め用のボスを形成する方法としては、従来、以下に示す 2 通りの方法が採用されていた。

30

## 【0003】

例えば図 6（a）に示すように、金属板 30 を折り曲げることにより位置決め部 31 及び係合部 32 を形成し、その係合部 32 と回路基板 33 に形成される位置決め用の孔 33a とを係合させて回路基板 33 を位置決めしていた。また、図 6（b）に示すように、樹脂からなるプリンタケース 40 からピン 41 を立て、金属板 42 と回路基板 43 とに設けられる孔 42a、43a にそのピン 41 を挿通することにより位置決めを行っていた。尚、通常は、回路基板の実装面側にも防火エンクロージャとして金属板が組み付けられる。

40

## 【0004】

先行技術文献情報は無し。その理由は、IPDL でサーチしましたが該当するものはありませんでした。なお、従来技術として挙げた図は、文献公知発明でなく公知・公用技術に基づくものです。

## 【0005】

## 【発明が解決しようとする課題】

しかし、前記したように金属板 30 の曲げ加工を行う場合や、プリンタケース 40 からピン 41 を立てる場合、防火エンクロージャの規格により回路基板における部品配置に制限が生じていた。すなわち、図 6（a）に示すような金属板 30 を曲げて位置決め部 31 を形成する場合は、その金属板 30 を折り曲げることにより形成される孔 30a から 5 度の角度の範囲に部品を配置してはならないという規格がある。また、図 6（b）に示すよ

50

うな樹脂からなるプリンタケース40からピン41を立てる場合は、その樹脂が防火エンクロージャーとして認められない材料の場合には点線で示すようにそのピン41から回路基板43の電子部品まで所定の距離(一例として13mm)離さなければならないという規格がある。このため、回路基板の電子部品の配置が制限され、それにより回路基板を大型化せざるを得ず、近年の回路基板の小型化のニーズに対応できないという問題があった。

#### 【0006】

本発明は、上記問題点を解決するためになされたものであって、その目的は、回路基板を防火エンクロージャーとしての金属板を介在させた状態で組み付ける構成において、部品配置に制限をなくし、回路基板の小型化が可能な回路基板の位置決め構造を提供することにある。

10

#### 【0007】

##### 【課題を解決するための手段】

上記問題点を解決するために、本発明は、回路基板の実装面側とは反対面側に設けられる防火エンクロージャーとしての金属板に対して回路基板の固定位置を決めるための回路基板の位置決め構造であって、前記回路基板は位置決め用の孔を有し、前記金属板を絞って突出形成された位置決め部が前記孔と係合することで位置決めをすることを要旨とする。

#### 【0008】

この発明によれば、位置決め部が防火エンクロージャーとして用いられる金属板を絞って突出形成されるため、従来のように金属板に孔が形成されることがなく、金属板が回路基板の裏側全体を覆うことができる。このため、規格による回路基板の部品配置の制限がなくなり、自由に部品を配置することが可能となる。また、基板の小型化が可能となる。

20

#### 【0009】

また、本発明は、前記位置決め部は前記金属板から錘状に突出するとともにその先端部に前記回路基板の孔と係合する係合部を有し、該係合部が前記孔と係合することで前記回路基板はその面方向において位置決めされるようになっており、該位置決め部の錘状に突出する斜面は該金属板の面方向に対して鈍角をなしていることを要旨とする。

#### 【0010】

この発明によれば、位置決め部の錘状に突出する斜面が金属板の面方向に対して鈍角をなす。すなわち錘状の位置決め部の斜面の立ち上がり角が鈍角となっている。このため、位置決め部の付け根部分に応力が集中しにくい。従って、金属板を絞って突出させた位置決め部に比較的強い剛性が付与される。また、位置決め部先端にある係合部と孔との係合により、回路基板を面方向に位置決めすることが可能となる。

30

#### 【0011】

さらに本発明は、前記位置決め部は、前記孔が前記係合部に係合された状態で前記回路基板を面方向と垂直な方向に位置決めする支持面を有することを要旨とする。

#### 【0012】

この発明によれば、位置決め部が有する支持面により、回路基板を面方向と垂直な方向に位置決めすることが可能となる。このため、回路基板と金属板との距離を所定間隔空けることができ、防火エンクロージャーの規格を満たすことができる。

40

#### 【0013】

また本発明では、前記位置決め部は、金属板を絞り加工することにより形成されることを要旨とする。

この発明によれば、防火エンクロージャーとしての金属板を絞り加工することで位置決め部は形成される。このため、従来のように金属板に孔が形成されることがなく位置決め部を形成することができ、また、比較的容易な絞り加工により位置決め部を簡単に形成することができる。

#### 【0014】

##### 【発明の実施の形態】

以下、本発明を具体化した回路基板の位置決め構造の一実施形態を図1～図3にしたがっ

50

て説明する。

【0015】

図1は、プリンタ（図示せず）に内蔵される回路基板ユニットの分解斜視図を示す。同図に示すように、回路基板ユニットUは、回路基板1、防火エンクロージャーとしての金属板2、3により構成される。以下の説明において、回路基板1の実装面側を表側とし、その反対面側を裏側とする。同図に示すように、回路基板1の表側に金属板3が、回路基板1の裏側に金属板2が取付けられる。

【0016】

図2は、回路基板ユニットの取付けを示す斜視図である。図1及び図2に示すように、金属板2、3は、回路基板1の形状・サイズに合わせて回路基板1とほぼ同形状・同サイズの四角板形状を有しており、回路基板1及び金属板2、3にはネジ挿通孔1a、2a、3aがそれぞれ形成されている。また、金属板2、3には後記する取付部18、19に形成されるネジ挿通孔18a、19aがそれぞれ形成されている。回路基板1及び金属板2、3は、それぞれのネジ挿通孔1a、2a、3a、18a及び19aに1本ずつ挿通したネジ10a（図2参照）により、樹脂製のプリンタハウジング（図示せず）内に收容された金属製のメカフレームFに螺着し、回路基板ユニットUとしてメカフレームFに組み付けられる。

【0017】

回路基板1には、USBコネクタ4、プリンタコネクタ5及び複数の回路素子6が回路基板1の裏側ではんだにより固定された状態で回路基板1の表側に実装されている。プリンタコネクタ5の両側には、ネジ挿通孔1aとともにネジ挿通孔1bが形成されている。また、回路基板1にはネジ挿通孔1dが形成されており、そのネジ挿通孔1dにネジ（図示せず）を挿通した状態で金属板2に形成される支持台8に固定される。このネジを介してメカフレームFには固定されない。また、回路基板1には、ネジ挿通孔1cが形成されており、ネジ挿通孔1bとともに金属板2、3と回路基板1とを固定するためのネジが挿通される。ネジ挿通孔1bには、金属板2、3に形成されるネジ挿通孔2b、3bとともにネジ10bが挿通され、ネジ挿通孔1cには、金属板2、3に形成されるネジ挿通孔2c、3cとともにネジ10cが挿通された状態で回路基板1及び金属板2、3が固定される。また、回路基板1には、位置決め用の孔1eが形成されており、この位置決め用の孔1eに位置決め部11の係合部12が係合する。

【0018】

金属板2、3は、アルミにより形成されており、防火の役割を果たすと同時に、放熱の役割を果たす。金属板3は、回路基板1に実装されるUSBコネクタ4及びプリンタコネクタ5を挿通するための開口部14、15を備え、それら開口部14、15にUSBコネクタ4及びプリンタコネクタ5を挿通した状態で金属板3は回路基板1の表側に組付けられる。また、プリンタコネクタ5の開口部15の両端には、ネジ挿通孔3aとともにネジ挿通孔3bが形成されている。これらネジ挿通孔3a、3bについては前記した通りである。また金属板3には、ネジ挿通孔18aを有する取付部18が形成されている。

【0019】

図3は、位置決め部の要部概略図である。図1及び図3に示すように金属板2には、回路基板1を位置決めするための位置決め部11が形成されている。位置決め部11は、金属板2を絞り加工することで形成される。位置決め部11は、金属板2の面方向に対して鈍角の斜面となるように形成されており、その形状は略円錐状に形成されている。位置決め部11の先端部には係合部12が形成されており、回路基板1に形成される位置決め用の孔1eと同形状ではあるが、若干小さいサイズで形成されている。このため、回路基板1の位置決め用の孔1eを係合部12に置くことで、係合部12が回路基板1の位置決め用の孔1eに係合し、回路基板1は面方向において位置決めされることとなる。また、係合部12の基端部には回路基板1を支持する支持面13が形成されている。この支持面13は、係合部12に回路基板1が係合される際に、回路基板1の裏側から回路基板1を支えることで回路基板1の面方向と垂直な方向において回路基板1の位置決めをすることが可

能となっている。さらに、回路基板 1 と金属板 2 の間は規格により所定の間隔空けなければならぬが、本実施形態では、位置決め部 11 の支持面 13 により位置決めとともにその間隔を確保することが可能である。

#### 【0020】

図 1 に示すように、金属板 2 の四辺のうち二辺には、金属板 2 を折り曲げることにより壁 16, 17 が形成されている。この壁 16, 17 は、回路基板 1 が位置決め部 11 の支持面 13 により支持される高さより若干高く形成されている。このため、係合部 12 により回路基板 1 を面方向において位置決めする際に、壁 16, 17 に回路基板 1 の四辺のうち二辺が当接することとなり、係合部 12 とともに面方向における回路基板 1 の位置決めをする役目を果たしている。また、壁 16 には、その壁 16 を折り曲げて、突出した状態の取付部 19 が形成されている。この取付部 19 はネジ挿通孔 19a を有し、金属板 3 のネジ挿通孔 18a とともにネジ 10a が挿通された状態でメカフレーム F に固定される。

10

#### 【0021】

金属板 2 には、支持台 7, 8 が形成されており、これら支持台 7, 8 は支持面 13 と同じ高さ形成されている。このため、回路基板 1 の位置決めの際に、支持面 13 とともに面方向と垂直な方向に回路基板 1 を位置決めする役目を果たしている。これら支持台 7, 8 にはそれぞれネジ挿通孔 2b, 2d が形成されており、ネジ挿通孔 2d は、回路基板 1 のネジ挿通孔 1d とともにネジが挿通された状態で回路基板 1 と金属板 2 が固定される。また、ネジ挿通孔 2b は、回路基板 1 のネジ挿通孔 1b 及び金属板 3 のネジ挿通孔 3b とともにネジが挿通された状態で回路基板 1 及び金属板 3 と取り付けられる。

20

#### 【0022】

次にこの回路基板の位置決め構造の作用について説明する。

図 1 に示すように、回路基板 1 と金属板 2 を取付ける際には、まず回路基板 1 の位置決め用の孔 1e を金属板 2 に形成される位置決め部 11 の係合部 12 に係合させる。これにより、係合部 12 が位置決め用の孔 1e に係合し、回路基板 1 の面方向において位置決めされる。また、係合部 12 の基端部に形成された支持面 13 により、回路基板 1 は係合するとともに支持面 13 により裏側から支持され、面方向と垂直な方向に位置決めもなされる。さらに、金属板 2 に形成されている壁 16, 17 に回路基板 1 の四辺のうち二辺が当接することで、さらに面方向において位置決めされることとなる。そして、これらにより回路基板 1 を位置決めした状態で、金属板 2 と回路基板 1 とを組付ける。詳しくは、支持台 8 のネジ挿通孔 2d と回路基板 1 のネジ挿通孔 1d にネジを挿通し、螺着することで回路基板 1 と金属板 2 とを組付ける。

30

#### 【0023】

次に、金属板 3 を回路基板 1 の表側に取付けることで回路基板ユニット U を形成する。詳しくは、金属板 3 のネジ挿通孔 3b, 3c とそれに対応する回路基板 1 のネジ挿通孔 1b, 1c 及び金属板 2 のネジ挿通孔 2b, 2c にそれぞれネジ 10b, 10c を挿通し、螺着することで金属板 3 が組付けられる。そして、これにより回路基板ユニット U が形成される。そして、図 2 に示すように、その回路基板ユニット U をネジ挿通孔 1a, 2a, 3a にそれぞれネジ 10a を挿通し、メカフレーム F に螺着して固定する。また、金属板 2 のネジ挿通孔 19a 及び金属板 3 のネジ挿通孔 18a にもネジ 10a を挿通し、螺着することでメカフレーム F に固定する。

40

#### 【0024】

上記実施形態によれば、以下のような効果を得ることができる。

(1) 防火エンクロージャとしての金属板 2 に絞り加工により位置決め部 11 を形成した。このため、従来のように金属板 2 に孔が形成されることがなく、金属板 2 が回路基板 1 の裏側全体を覆うことができる。従って、部品配置に制限が無くなり、部品を自由に配置でき、回路基板の小型化が可能である。また、絞り加工により位置決め部を形成するため容易に部品配置の制限を無くすることが可能である。

#### 【0025】

(2) 位置決め部 11 には、係合部 12 及び支持面 13 が形成されている。このため、回

50

路基板 1 は係合部 1 2 により面方向において位置決めされるとともに、支持面 1 3 により面方向と垂直な方向に位置決めされる。このため、ネジにより金属板 2 と固定する際に、予めネジ挿通孔を合わせることが可能である。従って、ネジによって固定する作業がし易くなる。

【0026】

(3) 位置決め部 1 1 は、金属板 2 の面方向に対して鈍角の斜面となるように形成されており、その形状は略円錐状に形成されている。このため、位置決め部の付け根部分に応力が集中しにくい。従って、金属板 2 を絞って突出させた位置決め部 1 1 の剛性を高めることができる。

【0027】

(4) 防火エンクロージャーとしての金属板 2 に位置決め部 1 1 を形成した。このため、位置決めのために別の金属板を設ける必要が無く、コストを低減することが可能である。また、省スペース化も可能である。

【0028】

(5) 金属板 2 は折り曲げることにより形成された壁 1 6, 1 7 を備え、位置決め部 1 1 の支持面 1 3 より若干高く形成されている。このため、回路基板 1 を位置決めする際に、係合部 1 2 により面方向に位置決めされるとともに、壁 1 6, 1 7 に回路基板 1 が当接することでさらに位置決めすることが可能となる。

【0029】

なお、前記実施形態は以下のように変更してもよい。

(変形例 1) 位置決め部 1 1 の形状は略円錐状の錐状に限定されない。例えば、図 4 (a) ~ (f) にそれぞれ示すような構造であってもよい。また、図 4 (a) 及び (d) に示す位置決め部 1 1 は、支持面を有していないが、係合部 1 2 の下側が回路基板 1 の位置決め用の孔 1 e よりも大きく形成されているため、支持面による位置決めほど正確ではないが回路基板 1 の面方向と垂直な方向に対して位置決めすることはできる。また、図 4 (e) は、回路基板 1 の面方向と垂直な方向は位置決めすることはできないが、面方向に対しては位置決めすることが可能である。しかし、金属板 2 には、支持台 7, 8 が形成されているため、位置決め部 1 1 が支持面を有していない場合でも面方向と垂直な方向に位置決めすることは可能である。

【0030】

(変形例 2) 位置決め部 1 1 は 1 つに限らず複数あってもよい。図 5 は、位置決め部 1 1 が 2 つの場合の例を示す。複数の場合は、面方向における縦又は横方向において同じ位置に形成することで、絞り加工による形成が容易となるが、これに限らない。また、位置決め部 1 1 が複数の場合、図 5 に示すように、回路基板 1 に設けられる複数の位置決め用の孔のうちどれか 1 つ以外は長孔 2 0 にすることで、回路基板 1 の位置決めの際の誤差をその長孔 2 0 で調整することができる。

【0031】

(変形例 3) 位置決め部 1 1 は金属板 2 を絞り加工することにより形成するに限らず、例えば、プレス加工で形成してもよい。これらによっても、回路基板 1 の裏側全体を金属板 2 により覆うことが可能であるため、同様の効果を得ることができる。

【0032】

(変形例 4) 回路基板 1 に形成される位置決め用の孔 1 e は円の形に限定されない。楕円や多角形等の形でもよい。楕円及び多角形で形成された場合、回路基板 1 の面方向における回転移動を規制することもできるため、より確実に位置決めを行うことが可能である。

【0033】

(変形例 5) 位置決め部 1 1 の係合部 1 2 は回路基板 1 の位置決め用の孔 1 e に対して若干小さい構成に限らない。係合部 1 2 が同じサイズ又は若干大きいサイズであってもよい。こうすることにより、係合部 1 2 が位置決め用の孔 1 e に嵌合することとなり位置決めだけでなく固定をすることが可能となる。

【0034】

次に、前記実施形態及び変形例から把握できる技術的思想について以下に追記する。

(1) 前記回路基板は、前記金属板が介在された状態で、組付け対象としての金属フレーム又は樹脂ケースに組付けられることを特徴とする請求項1～請求項4のいずれか一項に記載の回路基板の位置決め構造。

【0035】

(2) 前記金属板は、四辺のうち二辺において折り曲げることで形成された壁を備え、該壁が前記回路基板の四辺のうち二辺と当接することで前記位置決め部とともに面方向において位置決めをすることを特徴とする請求項1～請求項4及び前記技術的思想(1)のいずれか一項に記載の回路基板の位置決め構造。

【0036】

これによれば、金属板に形成される位置決め部とともに、金属板に形成される壁によって面方向において回路基板を位置決めすることが可能である。

(3) 前記金属板は、前記位置決め部とともに支持台を有し、該支持台が前記回路基板の実装面側と反対面側を支持することで、前記位置決め部とともに面方向と垂直な方向に位置決めをすることを特徴とする請求項1～請求項4及び前記技術的思想(1)及び(2)のいずれか一項に記載の回路基板の位置決め構造。

【0037】

これによれば、金属板に形成される位置決め部とともに、金属板に形成される支持台によって面方向と垂直な方向において位置決めすることが可能となる。

(4) 前記位置決め部は、プレス加工により形成されることを特徴とする請求項1～請求項3及び前記技術的思想(1)～(3)のいずれか一項に記載の回路基板の位置決め構造。

【0038】

これによれば、比較的容易なプレス加工により、位置決め部を簡単に形成することが可能である。

【図面の簡単な説明】

【図1】回路基板ユニットの分解斜視図。

【図2】回路基板ユニットの取付けを示す斜視図。

【図3】位置決め部の要部概略図。

【図4】(a)～(f)は別例における位置決め部の斜視図。

【図5】別例における回路基板及び金属板の斜視図。

【図6】(a)は、従来における位置決め部の要部概略図、(b)は、従来における位置決め用のピンの要部概略図。

【符号の説明】

1…回路基板、1e…位置決め用の孔、2, 3…防火エンクロージャーとしての金属板、6…回路素子、11…位置決め部、12…係合部、13…支持面。

10

20

30

【図1】

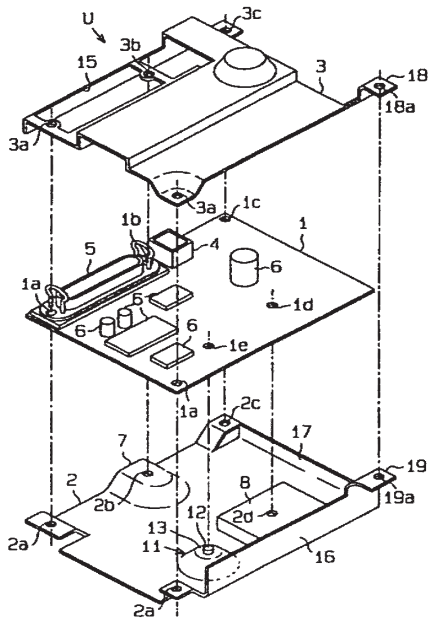

【図2】

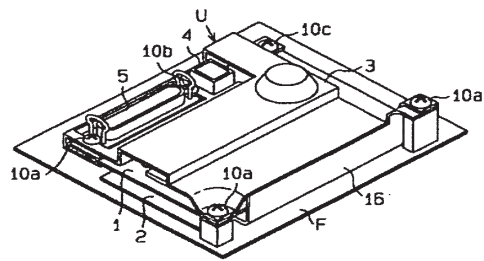

【図3】

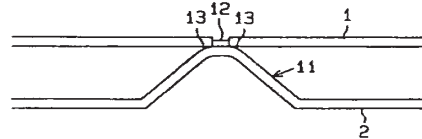

【図4】

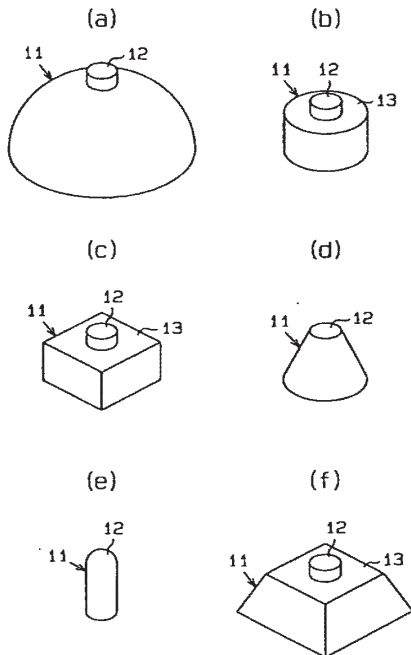

【図5】

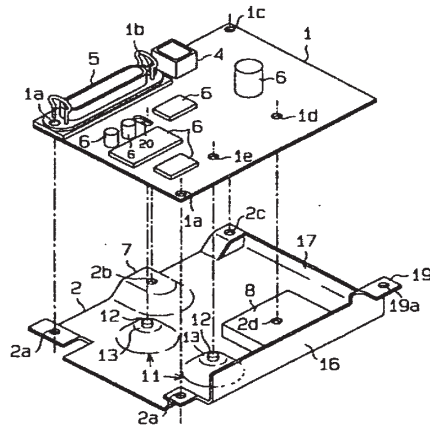

【図6】

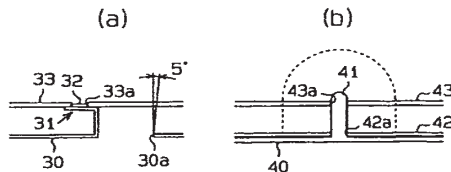

IFW

# IN THE UNITED STATES PATENT AND TRADEMARK OFFICE

IN RE APPLICATION OF: TOM CHUNG ET AL  
SERIAL NO.: 11/384,371

FILED: March 21, 2006

FOR: UNIVERSAL SERIAL BUS (USB) MEMORY APPARATUS



GROUP ART UNIT: 2841

EXAMINER: Y. SEMENENKO

ATTY. REFERENCE: CHUN3098/BEU

## COMMISSIONER OF PATENTS

P.O. Box 1450

Alexandria, VA 22313-1450

Sir:

Transmitted herewith is a communication/amendment in the above-identified application.

- Small entity status under 37 CFR 1.9 and 1.27 is claimed.
- No additional fee is required.

The fee, if any, has been calculated as shown below:

Fee Basis	Number of Claims After Amendment	Highest Number Previously Paid For	Extra Claims	Small Entity	Full Fee
Total Claims	-	<sup>1</sup>	= <sup>3</sup>	× \$ 25 =	× \$ 50 =
Independent Claims	-	<sup>2</sup>	= <sup>3</sup>	× \$ 100 =	× \$ 210 =
<input type="checkbox"/> First Presentation of Proper Multiple Dependent Claim				+ \$ 180 =	+ \$ 360 =
<b>TOTAL</b>					

<sup>1</sup> If less than 20 enter 20.

<sup>2</sup> If less than 3 enter 3.

<sup>3</sup> If less than 0 enter 0.

- Please charge my Deposit Account Number 02-0200 in the amount of \$ \_\_\_\_\_ . A duplicate copy of this sheet is attached.
- A check in the amount of \$ \_\_\_\_\_ is attached.
- The Commissioner is hereby authorized to charge any additional fees associated with this communication, including fees due under 37 CFR 1.16 and 37 CFR 1.17 or credit any overpayment to Deposit Account Number 02-0200. A duplicate copy of this sheet is attached.
- Also enclosed is/are: **4 - REPLACEMENT SHEETS (Figs. 1-9)**

23364  
Customer Number  
Phone: (703) 683-0500

DATE: July 24, 2008

Respectfully submitted,

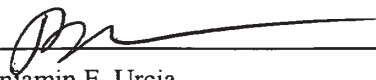
  
 Benjamin E. Urcia  
 Attorney for Applicant  
 Registration Number: 33,805





PATENT

IN THE UNITED STATES PATENT AND TRADEMARK OFFICE

<b>In re U.S. Patent Application of:</b>	)	<b>Group Art Unit: 2841</b>
	)	
<b>Tom CHUNG <i>et al.</i></b>	)	<b>Examiner: Y. Semenko</b>
	)	
<b>Serial Number: 11/384,371</b>	)	<b><i>Attorney Docket:</i> CHUN3098/BEU</b>
	)	
<b>Filed: March 21, 2006</b>	)	<b><u>Confirmation No.:</u> 8664</b>

**For: Universal Serial Bus (USB) Memory Apparatus**

AMENDMENT AND RESPONSE

Honorable Commissioner For Patents  
P.O. Box 1450  
Alexandria, VA. 22313-1450

Sir:

This paper is in response to the Official Action dated April 25, 2008.

Amendments to the specification are set forth on page 2.

Amendments to the claims begin on page 3.

Amendments to the drawings are set forth on page 7 and included in the attached REPLACEMENT SHEET.

Remarks/Arguments begin on page 8.

Serial Number 11/384,371

## AMENDMENTS TO SPECIFICATION

### In the Title:

Please amend the title, as follows:

–Universal Serial Bus (USB) Memory ~~Apparatus Plug~~–.

### Please amend paragraph [0010], as follows:

**[0010]** Accordingly, the prior art is limited by the above problems. It is an object of the present invention to provide a Universal Serial Bus (USB) memory apparatus, and in particular a USB memory plug, which decreases the cost, simplifies the manufacturing process, and is capable of introducing an extra module, such as a LED indicator, into the USB memory apparatus without increasing entirely the volume thereof.

## AMENDMENTS TO CLAIMS

This listing of claims will replace all prior versions, and listings, of claims in the application:

### **Listing of Claims:**

1. (Currently Amended) A Universal Serial Bus (USB) memory ~~apparatus~~ plug, comprising:
  - a housing having a plurality of orientated indentations and a plurality of concave props, wherein said plurality of orientated indentation facilitates said USB memory ~~apparatus~~ plug to be connected while said USB memory ~~apparatus~~ plug is inserted into a female USB socket; and
  - a print circuit board assembly (PCBA) disposed in said housing, wherein said PCBA is fixed by means of pressing of said plurality of concave props, and a space is formed between said housing and said PCBA.
  
2. (Currently amended) The USB memory ~~apparatus~~ plug according to claim 1, wherein said housing is made from a metallic conductive material.
  
3. (Cancelled)
  
4. (Currently amended) The USB memory ~~apparatus~~ plug according to claim 1, wherein said PCBA further comprises:
  - a memory controller;
  - a storage memory in communication with said memory controller;
  - a USB interface circuit in communication with said memory controller; and
  - an integrated circuit package for accommodating said memory controller, said storage memory, and said USB interface circuit together within physical dimensions of said USB memory ~~apparatus~~ plug.

Serial Number 11/384,371

5. (Currently amended) The USB memory ~~apparatus~~ plug according to claim 4, wherein said storage memory is one of a flash memory and an Electrically Erasable Programmable Read Only Memory (EEPROM).

6. (Currently amended) The USB memory ~~apparatus~~ plug according to claim 1, further comprising a LED indicator for indicating operation of said USB memory ~~apparatus~~ plug.

7. (Currently amended) The USB memory ~~apparatus~~ plug according to claim 6, wherein said PCBA further comprises a LED module controller for controlling said LED indicator.

8. (Currently amended) The USB memory ~~apparatus~~ plug according to claim 6, wherein said housing further comprises an opening for positioning said LED indicator.

9. (Currently amended) A USB memory ~~apparatus~~ plug, comprising:

a print circuit board assembly (PCBA); and

a housing having a plurality of concave props, wherein said PCBA is disposed in said housing; said plurality of concave props protrude inward to fix said PCBA, and a space is formed between said housing and said PCBA.

10. (Currently amended) The USB memory ~~apparatus~~ plug according to claim 9, wherein said housing is made from a metallic conductive material.

11. (Cancelled)

12. (Currently amended) The USB memory ~~apparatus~~ plug according to claim 9, wherein said PCBA further comprises:

a memory controller;

a storage memory in communication with said memory controller;

a USB interface circuit in communication with said memory controller; and

Serial Number 11/384,371

an integrated circuit package for accommodating said memory controller, said storage memory, and said USB interface circuit together within physical dimensions of said USB memory apparatus plug.

13. (Currently amended) The USB memory apparatus plug according to claim 12, wherein said storage memory is one of a flash memory and an Electrically Erasable Programmable Read Only Memory (EEPROM).

14. (Currently amended) The USB memory apparatus plug according to claim 9, further comprising a LED indicator for indicating operation of said USB memory apparatus plug.

15. (Currently amended) The USB memory apparatus plug according to claim 14, wherein said PCBA further comprises a LED module controller for controlling said LED indicator.

16. (Currently amended) The USB memory apparatus plug according to claim 14, wherein said housing further comprises an opening for positioning said LED indicator.

17. (Currently amended) A USB memory apparatus plug, comprising:

a housing having a plurality of orientated indentations and a plurality of concave props, wherein said plurality of orientated indentation facilitates said USB memory apparatus plug to be connected while said USB memory apparatus plug is inserted into a female USB socket;

a print circuit board assembly (PCBA) disposed in said housing, wherein said PCBA is fixed by means of pressing of said plurality of concave props; and

a LED module having a LED indicator disposed in said housing and a LED module controller disposed on said PCBA, wherein a space is formed between said housing and said PCBA for disposing said LED module.

18. (Currently amended) The USB memory apparatus plug according to claim 17, wherein said housing further comprises an opening for positioning said LED indicator.

**Serial Number 11/384,371**

19. (New) The USB memory plug according to claim 1, wherein the plurality of concave props are used to support said PCBA so that a space is formed between said housing and said PCBA.

20. (New) The USB memory plug according to claim 9, wherein the plurality of concave props are used to support said PCBA so that said PCBA is not in direct contact with said housing, and a space is formed between said housing and said PCBA.

21. (New) The USB memory plug according to claim 17, wherein the plurality of concave props are used to support said PCBA so that said PCBA is not in direct contact with said housing, and a space is formed between said housing and said PCBA.

22. (New) The USB memory plug according to claim 17, wherein said PCBA further comprises:  
a memory controller;  
a storage memory in communication with said memory controller;  
a USB interface circuit in communication with said memory controller; and  
an integrated circuit package for accommodating said memory controller, said storage memory, and said USB interface circuit together within physical dimensions of said USB memory plug.

23. (New) The USB memory plug according to claim 22, wherein the LED module projects from the integrated circuit package.

Serial Number 11/384,371

**AMENDMENTS TO DRAWINGS**

Please amend Figs. 1, 3, 5, and 8 by changing the double lines in element 11 to single lines, as indicated in the attached REPLACEMENT SHEETS.

## REMARKS

Reconsideration of the application is respectfully requested for the following reasons:

1. Amendments to Title, Specification, and Claims

The title, paragraph [0010] of the specification, and the claims have been amended by changing “apparatus” to –plug–. This change is supported by the drawings, which clearly show a plug, as well as by the description of the apparatus as being “inserted into a female USB socket” (paragraph [0010]).

In addition, claims 4 and 12 have been amended to clarify that the USB interface is a USB interface circuit, as described for example in lines 2-3 of paragraph [0014] of the original specification, and new claims 19-23 have been added to recite the space 53 illustrated in Fig. 6, the printed circuit board assembly 52 illustrated in Fig. 7, and projection of the LED module 841,842 from the integrated circuit package as illustrated in Fig. 9.

Because the amendments are all clearly supported by the original specification, it is respectfully submitted that they do not involve “new matter.”

2. Objection to Drawings

This objection has been addressed by amending the drawings to delete the double vertical lines objected-to in item 1 on page 2 of the Official Action.

3. Rejection of Claims 1-3, 9, 10, and 11 Under 35 USC §103(a) in view of Admitted Prior Art (AAPA) and U.S. Patent Publication No. 2004/0087213 (Kao)

This rejection is respectfully traversed on the grounds that the Kao publication does not disclose the feature, which is also not admitted to be prior art, of a USB plug housing having a plurality of concave props, wherein a printed circuit board assembly (PCBA) is fixed within the housing by means of pressing the plurality of concave props and a space is formed between the



Serial Number 11/384,371

housing and the PCBA. While the Kao publication discloses elastic plates 28 that arguably form “concave props,” the plates 28 of Kao are part of the receptacle structure for accommodating a USB plug housing, and not part of the USB memory plug structure itself.

Claim 1 specifically recites a USB memory plug comprising a housing, the housing having a plurality of orientated indentations and a plurality of concave props. Thus, the “concave props” are clearly recited as being included in the USB memory plug housing, and not a receptacle into which the housing is inserted. Furthermore, claim 1 specifically recites that the PCBA is disposed in the memory plug housing, *i.e.*, that both the PCBA and props are disposed within the housing, and further that ***the PCBA is fixed by means of pressing of said plurality of concave props***. Thus, claim 1 also clearly recites that the props are used to fix the PCBA in the plug housing, with a space being formed between the housing and the PCBA. The Examiner will note that this is not a purely functional limitation, but rather is a structural limitation in “means” format.

In contrast, the cited passages in paragraph [0006] of the Kao publication describe elastic plates 28 as being included in a receptacle 40 that *receives* USB plug 10, the plates 28 being arranged on an up and down side of receptacle outer frame 26 to “*elastically contact to the metal frame 16 [of the USB plug] so as to affix the plug 10*” (paragraph [0006], lines 15-20). Plates 28 of Kao are therefore not included in the plug 10, but rather are provided in a separate receptacle into which the plug is inserted. Furthermore, plates 28 of Kao do not affix a PCBA in a plug housing, as claimed, but rather engage the exterior of the plug housing to fix the plug housing in a receptacle. As a result, plates 28 of Kao do not correspond to the claimed “concave props,” and Kao does not teach this feature of the invention recited in claim 1.

In addition, it is respectfully noted that claim 1 also recites that it is the orientated indentations that permit connection of the plug to corresponding contacts in a receptacle. This is explained in paragraph [0040] of the present application. According to claim 1, the plug housing includes both the orientated indentations, for connection to the receptacle, and concave

Serial Number 11/384,371

props for fixing the PCBA in the housing. If plates 28 of Kao were interpreted as corresponding to the claimed props, then the claimed “housing” would need to correspond to outer frame 26 rather than to the plug housing. Outer frame 26 does not include any sort of orientated indentations, and therefore claim 1 would still not be anticipated by the Kao publication.

Since the claimed housing comprising orientated indentations and contact props for fixing a PCBA in the housing are not disclosed in the admitted prior art, and are not taught by the Kao publication, it is respectfully submitted that the proposed combination of the admitted prior art and the teachings of Kao would not have rendered obvious the invention recited in claim 1, and withdrawal of the rejection is respectfully requested.

In addition, it is respectfully submitted that the feature recited in claim 2, namely that the housing (and therefore the props which are part of the housing), is also clearly not taught by Kao or admitted to be prior art. The elastic plates of Kao are solely for support purposes and are not conductive.

Still further, it is respectfully submitted that independent claim 9 is patentable because the admitted prior art and Kao publication, whether considered individually or in any reasonable combination, fails to disclose or suggest a USB plug housing with a plurality of concave props protruding inwardly to fix a PCBA, as opposed to plates or props in a receptacle used to fix a USB plug. Finally, the remaining claims included in this rejection (3, 10, and 11) are at least patentable because of their dependence from one of claims 1 and 9. Therefore, withdrawal of the rejection of claims 1-3 and 9-11 under 35 USC §103(a) is respectfully requested.

4. Rejection of Claims 4-8 and 12-18 Under 35 USC §103(a) in view of Admitted Prior Art (AAPA) and U.S. Patent Publication Nos. 2004/0087213 (Kao) and 2007/0178769 (Ni)

This rejection is respectfully traversed on the grounds that the Ni publication, like the Kao publication, does not disclose the feature of a USB plug housing having a plurality of concave props, wherein a printed circuit board assembly (PCBA) is fixed within the housing by pressing

Serial Number 11/384,371

the plurality of concave props and a space is formed between the housing and the PCBA. Claims 4-8 and 12-18 depend respectively from claims 1 and 9, and therefore include the features recited therein, including the claimed USB plug housing comprising concave props.

It is true that the plug housing described in col. 8, lines 54 *et seq.* of Ni includes support ribs that appear to provide a space between the PCBA and the housing (see Figs. 4(A) and 4(B), elements 356C and 357C), but the supports 356C and 357C do not correspond to the claimed props since they do not actually fix the PCBA 110 in the housing. Instead, PCB is fixed by “snap-coupling” upper and lower housing portions over the PCBA 110 as described in lines 11-38 of col. 9 of the Ni publication. Therefore, Ni does not teach the claimed concave props, and does not make up for the deficiencies of the Kao publication and the admitted prior art. Withdrawal of the rejection of claims 4-8 and 12-18 under 35 USC §103(a) is respectfully requested.

Having thus overcome each of the rejections made in the Official Action, withdrawal of the rejections and expedited passage of the application to issue is requested.

Respectfully submitted,

BACON & THOMAS, PLLC



By: BENJAMIN E. URZIA  
Registration No. 33,805

Date: July 24, 2008

BACON & THOMAS, PLLC  
625 Slaters Lane, 4th Floor  
Alexandria, Virginia 22314

Telephone: (703) 683-0500

NWB.S:\Product\bae\Printing A...HC\CTH\NO 384371\01.wpd

REPLACEMENT SHEET

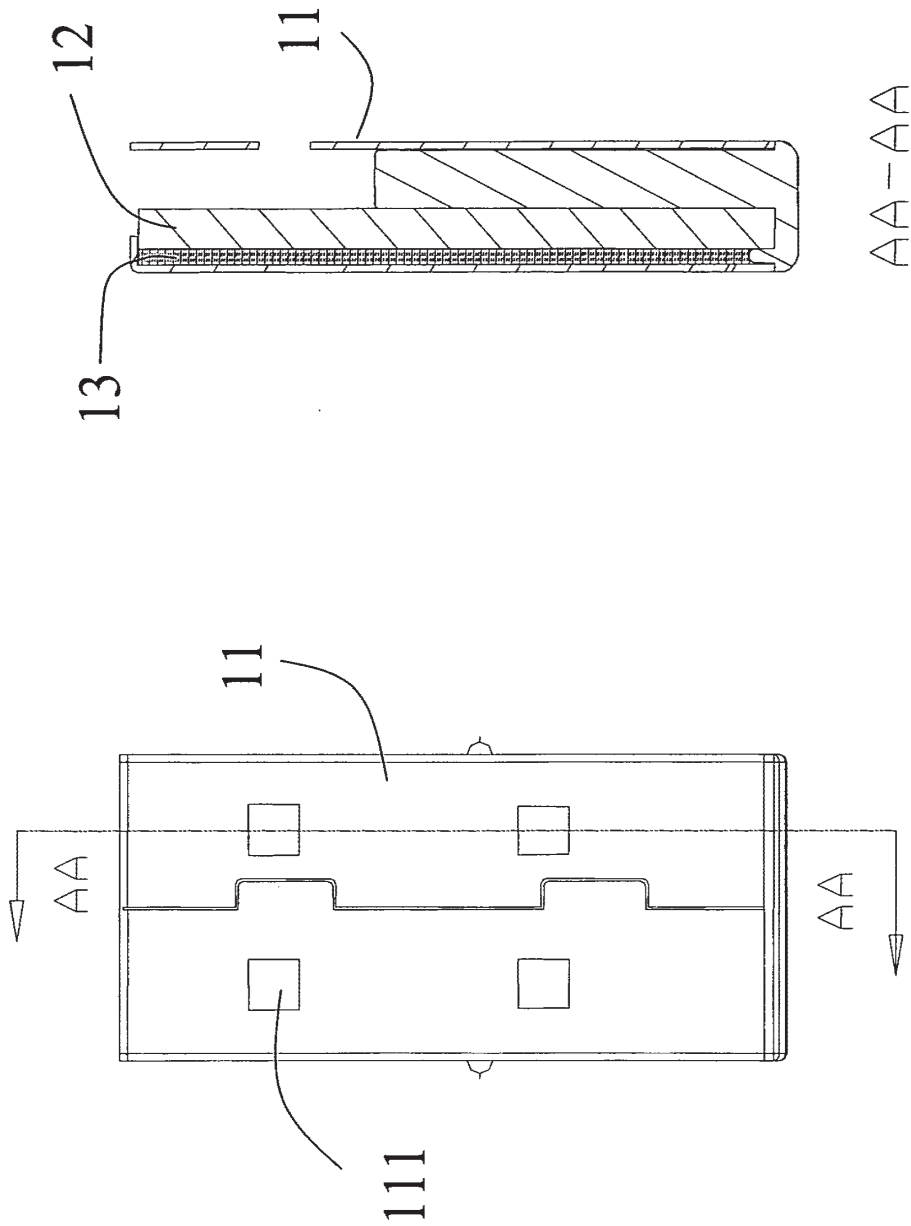

Fig. 2  
(Prior Art)

Fig. 1  
(Prior Art)

REPLACEMENT SHEET

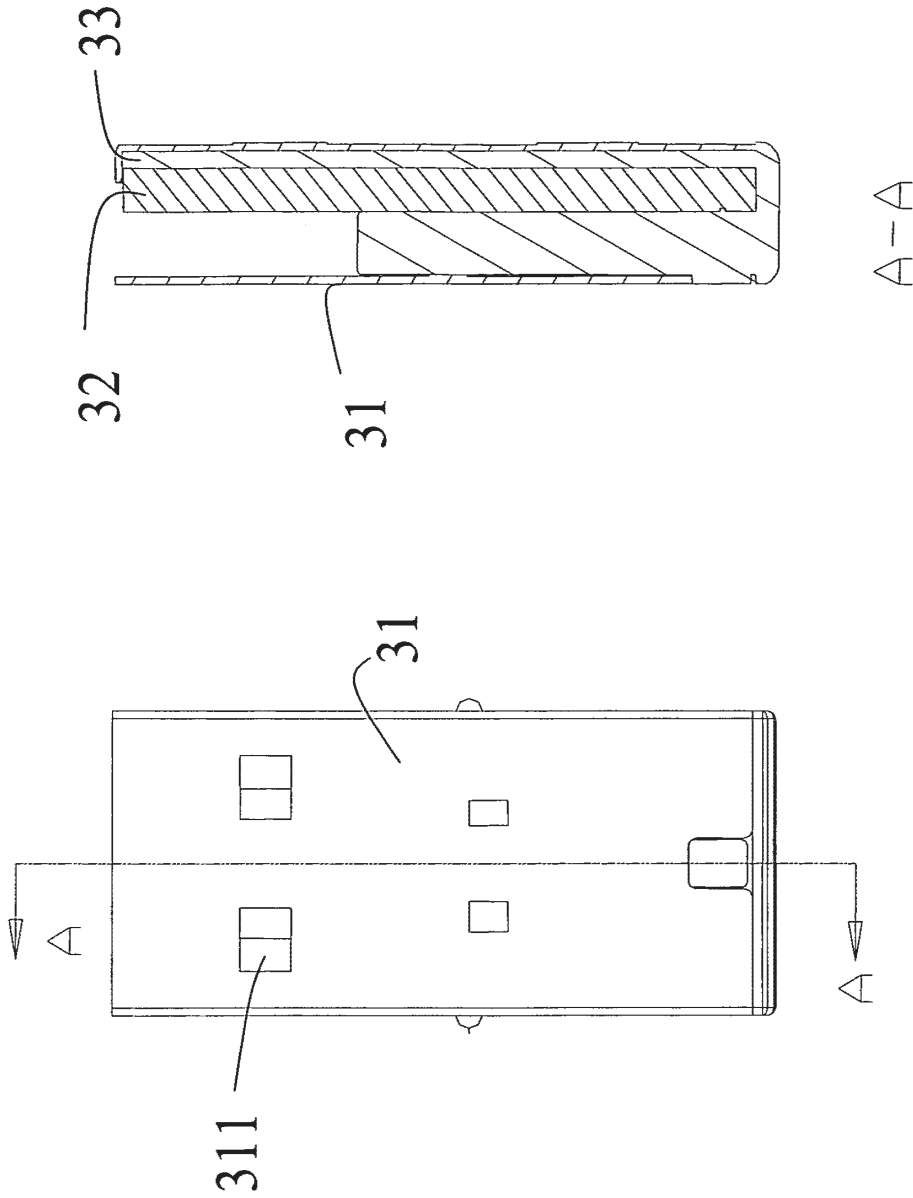

Fig. 4  
(Prior Art)

Fig. 3  
(Prior Art)

REPLACEMENT SHEET

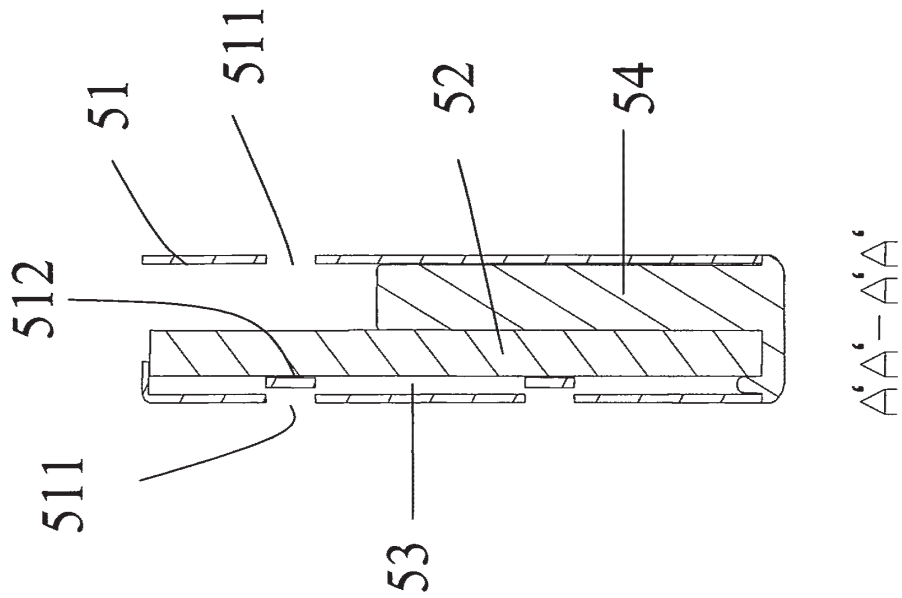

Fig. 5

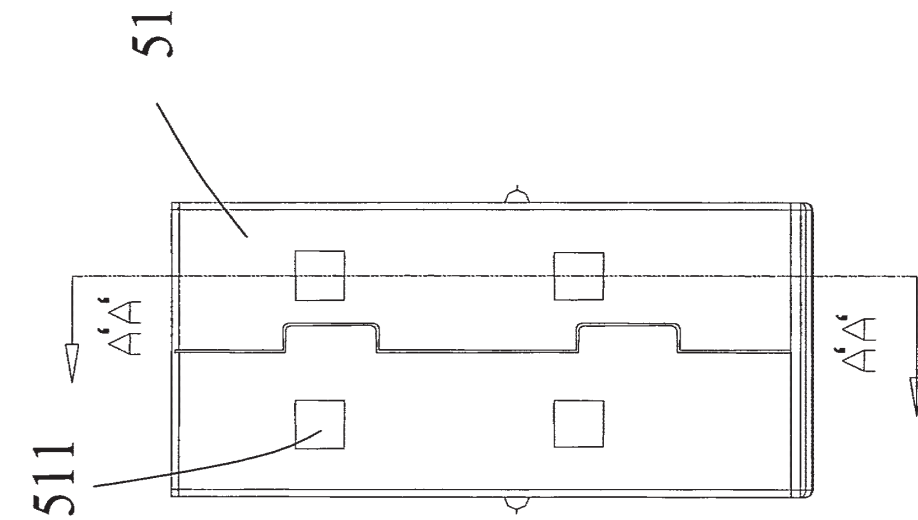

Fig. 6

REPLACEMENT SHEET

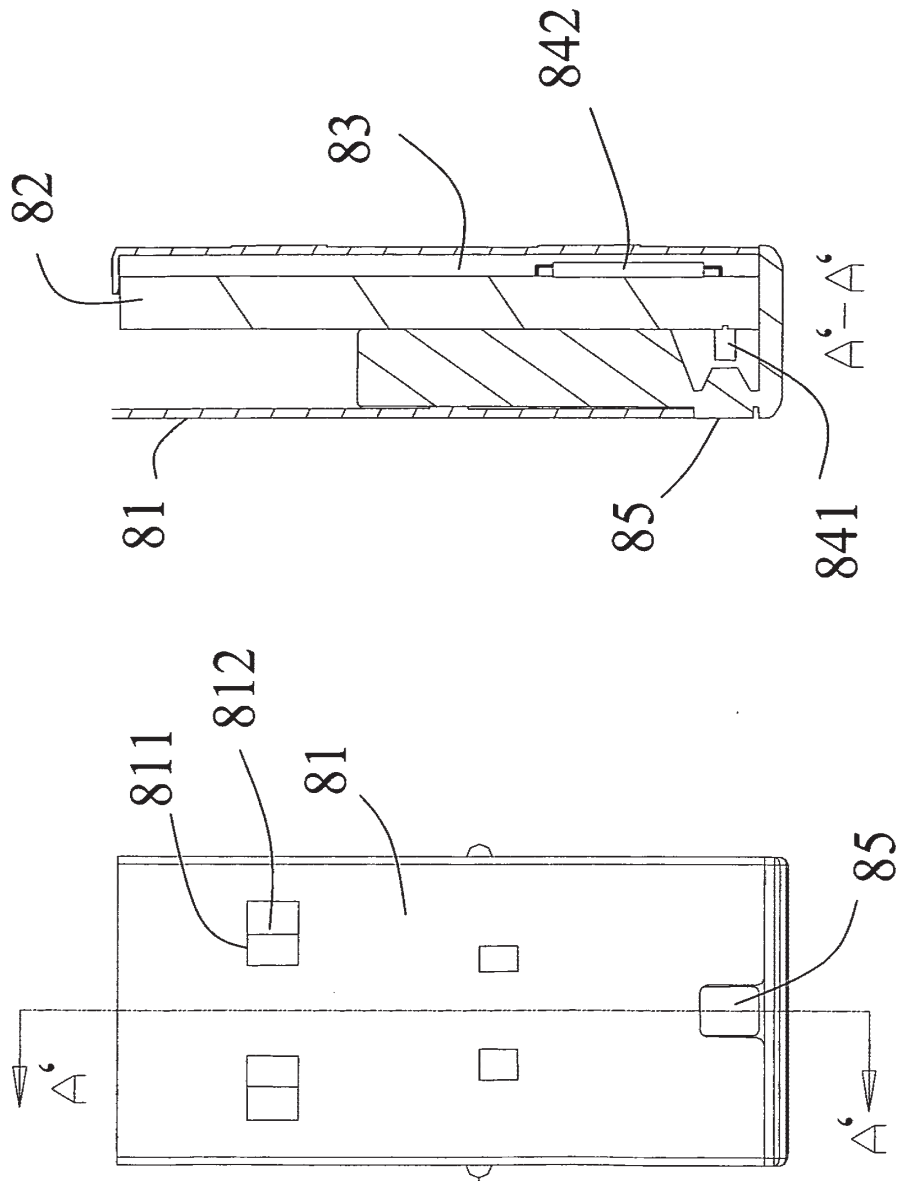

Fig. 9

Fig. 8

Under the Paperwork Reduction Act of 1995, no persons are required to respond to a collection of information unless it displays a valid OMB control number.

<b>PATENT APPLICATION FEE DETERMINATION RECORD</b> Substitute for Form PTO-875					Application or Docket Number <b>11/384,371</b>		Filing Date <b>03/21/2006</b>		<input type="checkbox"/> To be Mailed		
<b>APPLICATION AS FILED – PART I</b>											
(Column 1)			(Column 2)		SMALL ENTITY <input checked="" type="checkbox"/> OR			OTHER THAN SMALL ENTITY			
FOR	NUMBER FILED	NUMBER EXTRA	RATE (\$)	FEE (\$)	OR	RATE (\$)	FEE (\$)				
<input type="checkbox"/> BASIC FEE (37 CFR 1.16(a), (b), or (c))	N/A	N/A	N/A			N/A					
<input type="checkbox"/> SEARCH FEE (37 CFR 1.16(k), (l), or (m))	N/A	N/A	N/A			N/A					
<input type="checkbox"/> EXAMINATION FEE (37 CFR 1.16(o), (p), or (q))	N/A	N/A	N/A			N/A					
TOTAL CLAIMS (37 CFR 1.16(i))	minus 20 =	*	X \$ =		OR	X \$ =					
INDEPENDENT CLAIMS (37 CFR 1.16(h))	minus 3 =	*	X \$ =			X \$ =					
<input type="checkbox"/> APPLICATION SIZE FEE (37 CFR 1.16(s))	If the specification and drawings exceed 100 sheets of paper, the application size fee due is \$250 (\$125 for small entity) for each additional 50 sheets or fraction thereof. See 35 U.S.C. 41(a)(1)(G) and 37 CFR 1.16(s).										
<input type="checkbox"/> MULTIPLE DEPENDENT CLAIM PRESENT (37 CFR 1.16(j))											
* If the difference in column 1 is less than zero, enter "0" in column 2.											
TOTAL			TOTAL		TOTAL			TOTAL			
<b>APPLICATION AS AMENDED – PART II</b>											
(Column 1)			(Column 2)		(Column 3)			SMALL ENTITY OR		OTHER THAN SMALL ENTITY	
AMENDMENT	<b>07/24/2008</b>	CLAIMS REMAINING AFTER AMENDMENT		HIGHEST NUMBER PREVIOUSLY PAID FOR	PRESENT EXTRA	RATE (\$)	ADDITIONAL FEE (\$)	OR	RATE (\$)	ADDITIONAL FEE (\$)	
	Total (37 CFR 1.16(o))	* 20	Minus	** 20	= 0	X \$25 =	0	OR	X \$ =		
	Independent (37 CFR 1.16(h))	* 3	Minus	***3	= 0	X \$105 =	0	OR	X \$ =		
	<input type="checkbox"/> Application Size Fee (37 CFR 1.16(s))										
	<input type="checkbox"/> FIRST PRESENTATION OF MULTIPLE DEPENDENT CLAIM (37 CFR 1.16(j))										
TOTAL ADD'L FEE						<b>0</b>		OR		TOTAL ADD'L FEE	
AMENDMENT		CLAIMS REMAINING AFTER AMENDMENT		HIGHEST NUMBER PREVIOUSLY PAID FOR	PRESENT EXTRA	RATE (\$)	ADDITIONAL FEE (\$)	OR	RATE (\$)	ADDITIONAL FEE (\$)	
	Total (37 CFR 1.16(o))	*	Minus	**	=	X \$ =		OR	X \$ =		
	Independent (37 CFR 1.16(h))	*	Minus	***	=	X \$ =		OR	X \$ =		
	<input type="checkbox"/> Application Size Fee (37 CFR 1.16(s))										
	<input type="checkbox"/> FIRST PRESENTATION OF MULTIPLE DEPENDENT CLAIM (37 CFR 1.16(j))										
TOTAL ADD'L FEE								OR		TOTAL ADD'L FEE	
* If the entry in column 1 is less than the entry in column 2, write "0" in column 3.											
** If the "Highest Number Previously Paid For" IN THIS SPACE is less than 20, enter "20".											
*** If the "Highest Number Previously Paid For" IN THIS SPACE is less than 3, enter "3".											
The "Highest Number Previously Paid For" (Total or Independent) is the highest number found in the appropriate box in column 1.											
Legal Instrument Examiner: /JERMAINE D. MINOR/											

This collection of information is required by 37 CFR 1.16. The information is required to obtain or retain a benefit by the public which is to file (and by the USPTO to process) an application. Confidentiality is governed by 35 U.S.C. 122 and 37 CFR 1.14. This collection is estimated to take 12 minutes to complete, including gathering, preparing, and submitting the completed application form to the USPTO. Time will vary depending upon the individual case. Any comments on the amount of time you require to complete this form and/or suggestions for reducing this burden, should be sent to the Chief Information Officer, U.S. Patent and Trademark Office, U.S. Department of Commerce, P.O. Box 1450, Alexandria, VA 22313-1450. DO NOT SEND FEES OR COMPLETED FORMS TO THIS ADDRESS. **SEND TO: Commissioner for Patents, P.O. Box 1450, Alexandria, VA 22313-1450.**

If you need assistance in completing the form, call 1-800-PTO-9199 and select option 2.



Document code: WFEE

United States Patent and Trademark Office  
Sales Receipt for Accounting Date: 12/12/2008

TBELL2 SALE #00000001 Mailroom Dt: 07/24/2008 020200 11384371  
01 FC : 2202 25.00 DA

Under the Paperwork Reduction Act of 1995, no persons are required to respond to a collection of information unless it displays a valid OMB control number.

<b>PATENT APPLICATION FEE DETERMINATION RECORD</b> Substitute for Form PTO-875					Application or Docket Number <b>11/384,371</b>		Filing Date <b>03/21/2006</b>		<input type="checkbox"/> To be Mailed	
<b>APPLICATION AS FILED – PART I</b>										
(Column 1)			(Column 2)		SMALL ENTITY <input checked="" type="checkbox"/> OR			OTHER THAN SMALL ENTITY		
FOR	NUMBER FILED	NUMBER EXTRA	RATE (\$)	FEE (\$)	OR			RATE (\$)	FEE (\$)	
<input type="checkbox"/> BASIC FEE <small>(37 CFR 1.16(a), (b), or (c))</small>	N/A	N/A	N/A	N/A				N/A	N/A	
<input type="checkbox"/> SEARCH FEE <small>(37 CFR 1.16(k), (l), or (m))</small>	N/A	N/A	N/A	N/A	N/A	N/A				
<input type="checkbox"/> EXAMINATION FEE <small>(37 CFR 1.16(o), (p), or (q))</small>	N/A	N/A	N/A	N/A	N/A	N/A				
TOTAL CLAIMS <small>(37 CFR 1.16(i))</small>	minus 20 =	*	X \$ =		OR			X \$ =		
INDEPENDENT CLAIMS <small>(37 CFR 1.16(h))</small>	minus 3 =	*	X \$ =					X \$ =		
<input type="checkbox"/> APPLICATION SIZE FEE <small>(37 CFR 1.16(s))</small>	If the specification and drawings exceed 100 sheets of paper, the application size fee due is \$250 (\$125 for small entity) for each additional 50 sheets or fraction thereof. See 35 U.S.C. 41(a)(1)(G) and 37 CFR 1.16(s).									
<input type="checkbox"/> MULTIPLE DEPENDENT CLAIM PRESENT <small>(37 CFR 1.16(j))</small>										
* If the difference in column 1 is less than zero, enter "0" in column 2.										
<b>APPLICATION AS AMENDED – PART II</b>										
(Column 1)			(Column 2)		(Column 3)			SMALL ENTITY OR OTHER THAN SMALL ENTITY		
AMENDMENT	<b>07/24/2008</b>	CLAIMS REMAINING AFTER AMENDMENT		HIGHEST NUMBER PREVIOUSLY PAID FOR	PRESENT EXTRA	RATE (\$)	ADDITIONAL FEE (\$)		RATE (\$)	ADDITIONAL FEE (\$)
	Total <small>(37 CFR 1.16(o))</small>	* 21	Minus	** 20	= 1	X \$25 =	25	OR	X \$ =	
	Independent <small>(37 CFR 1.16(h))</small>	* 3	Minus	***3	= 0	X \$105 =	0	OR	X \$ =	
	<input type="checkbox"/> Application Size Fee <small>(37 CFR 1.16(s))</small>									
	<input type="checkbox"/> FIRST PRESENTATION OF MULTIPLE DEPENDENT CLAIM <small>(37 CFR 1.16(j))</small>									
						TOTAL ADD'L FEE	<b>25</b>	OR	TOTAL ADD'L FEE	
AMENDMENT		CLAIMS REMAINING AFTER AMENDMENT		HIGHEST NUMBER PREVIOUSLY PAID FOR	PRESENT EXTRA	RATE (\$)	ADDITIONAL FEE (\$)		RATE (\$)	ADDITIONAL FEE (\$)
	Total <small>(37 CFR 1.16(o))</small>	*	Minus	**	=	X \$ =		OR	X \$ =	
	Independent <small>(37 CFR 1.16(h))</small>	*	Minus	***	=	X \$ =		OR	X \$ =	
	<input type="checkbox"/> Application Size Fee <small>(37 CFR 1.16(s))</small>									
	<input type="checkbox"/> FIRST PRESENTATION OF MULTIPLE DEPENDENT CLAIM <small>(37 CFR 1.16(j))</small>									
						TOTAL ADD'L FEE		OR	TOTAL ADD'L FEE	
* If the entry in column 1 is less than the entry in column 2, write "0" in column 3.										
** If the "Highest Number Previously Paid For" IN THIS SPACE is less than 20, enter "20".										
*** If the "Highest Number Previously Paid For" IN THIS SPACE is less than 3, enter "3".										
The "Highest Number Previously Paid For" (Total or Independent) is the highest number found in the appropriate box in column 1.										
						Legal Instrument Examiner: /TRACEY BELL/				

This collection of information is required by 37 CFR 1.16. The information is required to obtain or retain a benefit by the public which is to file (and by the USPTO to process) an application. Confidentiality is governed by 35 U.S.C. 122 and 37 CFR 1.14. This collection is estimated to take 12 minutes to complete, including gathering, preparing, and submitting the completed application form to the USPTO. Time will vary depending upon the individual case. Any comments on the amount of time you require to complete this form and/or suggestions for reducing this burden, should be sent to the Chief Information Officer, U.S. Patent and Trademark Office, U.S. Department of Commerce, P.O. Box 1450, Alexandria, VA 22313-1450. DO NOT SEND FEES OR COMPLETED FORMS TO THIS ADDRESS. SEND TO: Commissioner for Patents, P.O. Box 1450, Alexandria, VA 22313-1450.

If you need assistance in completing the form, call 1-800-PTO-9199 and select option 2.



UNITED STATES PATENT AND TRADEMARK OFFICE

UNITED STATES DEPARTMENT OF COMMERCE
United States Patent and Trademark Office
Address: COMMISSIONER FOR PATENTS
P.O. Box 1450
Alexandria, Virginia 22313-1450
www.uspto.gov

Table with 5 columns: APPLICATION NO., FILING DATE, FIRST NAMED INVENTOR, ATTORNEY DOCKET NO., CONFIRMATION NO. Includes details for application 11/384,371 filed 03/21/2006 by Tom Chung, attorney CHUN3098/EM, examiner SEMENENKO, YURIY, art unit 2841, and mail date 04/25/2008.

Please find below and/or attached an Office communication concerning this application or proceeding.

The time period for reply, if any, is set in the attached communication.



## **DETAILED ACTION**

### ***Drawings***

1. The drawings are objected to because “a plurality of orientated indentations” 111, Fig.1, 511, Fig. 6 should not have double vertical lines, accordingly to Fig. 2 and Fig. 6 respectively. Corrected drawing sheets in compliance with 37 CFR 1.121(d) are required in reply to the Office action to avoid abandonment of the application. Any amended replacement drawing sheet should include all of the figures appearing on the immediate prior version of the sheet, even if only one figure is being amended. The figure or figure number of an amended drawing should not be labeled as “amended.” If a drawing figure is to be canceled, the appropriate figure must be removed from the replacement sheet, and where necessary, the remaining figures must be renumbered and appropriate changes made to the brief description of the several views of the drawings for consistency. Additional replacement sheets may be necessary to show the renumbering of the remaining figures. Each drawing sheet submitted after the filing date of an application must be labeled in the top margin as either “Replacement Sheet” or “New Sheet” pursuant to 37 CFR 1.121(d). If the changes are not accepted by the examiner, the applicant will be notified and informed of any required corrective action in the next Office action. The objection to the drawings will not be held in abeyance.

### ***Claim Rejections - 35 USC § 103***

2. The following is a quotation of 35 U.S.C. 103(a) which forms the basis for all obviousness rejections set forth in this Office action:

(a) A patent may not be obtained though the invention is not identically disclosed or described as set forth in section 102 of this title, if the differences between the subject matter sought to be patented and the prior art are such that the subject matter as a whole would have been obvious at the time the invention was made to a person having ordinary skill in the art to which said subject matter pertains. Patentability shall not be negated by the manner in which the invention was made.

The factual inquiries set forth in *Graham v. John Deere Co.*, 383 U.S. 1, 148 USPQ 459 (1966), that are applied for establishing a background for determining obviousness under 35 U.S.C. 103(a) are summarized as follows:

1. Determining the scope and contents of the prior art.
2. Ascertaining the differences between the prior art and the claims at issue.
3. Resolving the level of ordinary skill in the pertinent art.
4. Considering objective evidence present in the application indicating obviousness or nonobviousness.

2.1. Claims 1 – 3, 9, 10 and 11 are rejected under 35U.S.C. 103(a) as being unpatentable over Admitted by Applicant Prior Art (Background of Invention section), hereinafter AAPA in view of Kao, (PGPub. No: 2004/0087213), [hereinafter Kao].

As to claim 1: AAPA discloses in Fig. 1 a Universal Serial Bus (USB) memory apparatus, comprising: a housing 11 having a plurality of orientated indentations 111, wherein said plurality of orientated indentation facilitates said USB memory apparatus to be connected while said USB memory apparatus is inserted into a female USB socket (not shown); and a print circuit board assembly (PCBA) 12 disposed in said housing 11, except, AAPA doesn't disclose a housing having a plurality of concave props; wherein said PCBA is fixed by means of pressing of said plurality of concave props, and a space is formed between said housing and said PCBA.

Kao discloses in the "Background of the invention" section, at the time the invention was made, that it was well known to use for plug 10, Fig . 1-2 and receptacle a housing 26 having a plurality of elastic props 28; wherein holder 24 is fixed by means of pressing of said plurality of elastic props 28, Fig. 2, and a space is formed between said housing 26 and the holder 24, [0006].

Therefore it would have been obvious to one of ordinary skill in the art, at the time the invention was made for AAPA to include in his invention a housing having a plurality of concave props; wherein said PCBA is fixed by means of pressing of said plurality of concave props, and a space is formed between said housing and said PCBA, as taught by Kao, in order to affix the plug, as taught by Kao (page 1, [0006]).

As to claim 9: AAPA discloses in Fig. 1a USB memory apparatus, comprising: a print circuit board assembly (PCBA), 12 ; and a housing 11, wherein said PCBA, 12 is disposed in said housing 11;

except, AAPA doesn't disclose a housing having a plurality of concave props; said plurality of concave props protrude inward to fix said PCBA, and a space is formed between said housing and said PCBA.

Kao discloses in the "Background of the invention" section, at the time the invention was made, that it was well known to use for plug 10, Fig . 1-2 and receptacle a housing 26 having a plurality of elastic props 28; wherein holder 24 is fixed by means of pressing of said plurality of elastic props 28, Fig. 2, and a space is formed between said housing 26 and the holder 24, [0006].

Therefore it would have been obvious to one of ordinary skill in the art, at the time the invention was made for AAPA to include in his invention a housing having a plurality of concave props; said plurality of concave props protrude inward to fix said PCBA, and a space is formed between said housing and said PCBA, as taught by Kao, in order to affix the plug, as taught by Kao (page 1, [0006]).

As to claims 2 and 10: AAPA as modified by the teaching of Kao, discloses the USB memory apparatus having all of the claimed features as discussed above with respect to claim 1(9), wherein said housing is made from a metallic conductive material (specification, page 2, [0006]).

As to claims 3 and 11: AAPA as modified by the teaching of Kao, discloses the USB memory apparatus having all of the claimed features as discussed above with respect to claim 1(9). Although AAPA does not explicitly teach said plurality of orientated indentations and said plurality of concave props are integrally formed by means of punching on said housing. However, the Examiner notes that the limitations "formed by means of punching on said housing" are process limitations in product claims. Such process limitations define the claimed invention over the prior art only to the degree that

they define the product itself. A process limitation cannot serve to patentably distinguish the product over the prior art, in the case that the product is the same as, or obvious over, the prior art. See Product-by-Process in MPEP 2113 and 2173.05(p) and *In re Thorpe*, 227 USPQ 964, 966 (Fed. Cir. 1985).

Therefore it would have been obvious to one of ordinary skill in the art, at the time the invention was made for AAPA to include in his invention said plurality of orientated indentations and said plurality of concave props are integrally formed by means of punching on said housing in order to reduce cost of the manufacturing process.

2.2. Claims 4 – 8, 12 - 17 and 18 are rejected under 35 U.S.C. 103(a) as being unpatentable over AAPA in view of Kao, as applied to claims 1 - 3 and 9 - 11 respectively above, and further in view of Ni (PGPub. #2007/0178769) hereinafter Ni.

As to claim 17: AAPA discloses in Fig. 1 a USB memory apparatus, comprising: a housing 11 having a plurality of orientated indentations 111, wherein said plurality of orientated indentation facilitates said USB memory apparatus to be connected while said USB memory apparatus is inserted into a female USB socket (not shown); a print circuit board assembly (PCBA), 12 disposed in said housing 11,

except, AAPA doesn't disclose a housing having a plurality of concave props; wherein said PCBA is fixed by means of pressing of said plurality of concave props, and a space is formed between said housing and said PCBA.

Kao discloses in the "Background of the invention" section, at the time the invention was made, that it was well known to use for plug 10, Fig. 1-2 and receptacle a housing 26 having a plurality of elastic props 28; wherein holder 24 is fixed by means of pressing of said plurality of elastic props 28, Fig. 2, and a space is formed between said housing 26 and the holder 24, [0006].

Therefore it would have been obvious to one of ordinary skill in the art, at the time the invention was made for AAPA to include in his invention a housing having a plurality of concave props; wherein said PCBA is fixed by means of pressing of said



plurality of concave props, and a space is formed between said housing and said PCBA, as taught by Kao, in order to affix the plug, as taught by Kao (page 1, [0006]).

AAPA also fail to disclose a LED module having a LED indicator disposed in said housing and a LED module controller disposed on said PCBA], wherein a space is formed between said housing and said PCBA for disposing said LED module.

Ni teaches Fig. 11 a LED module [0068] having a LED indicator 770 disposed in said housing 710 and a LED module controller disposed on said PCBA 735 and [0068], wherein a space is formed between said housing and said PCBA for disposing said LED module.

Therefore it would have been obvious to one of ordinary skill in the art, at the time the invention was made for AAPA to include in his invention a LED module having a LED indicator disposed in said housing and a LED module controller disposed on said PCBA], wherein a space is formed between said housing and said PCBA for disposing said LED module, as taught by Ni, in order to provide customer with indication of the communications.

As to claims 4, 5, 12 and 13: AAPA as modified by the teaching of Kao, discloses the USB memory apparatus having all of the claimed features as discussed above with respect to claim 1(9),

except AAPA does not explicitly teach said PCBA further comprises: a memory controller [0068]; a storage memory (Electrically Erasable Programmable Read Only Memory (EEPROM), in communication with said memory controller; a USB interface circuit in communication with said memory controller; and an integrated circuit package for accommodating said memory controller, said storage memory, and said USB interface together within physical dimensions of said USB memory apparatus.

Ni teaches Fig. 11 said PCBA 735, Fig.11, further comprises: a memory controller [0068]; a storage memory (Electrically Erasable Programmable Read Only Memory (EEPROM), [0068]) in communication with said memory controller; a USB interface circuit 730 in communication with said memory controller; and an integrated circuit package for accommodating said memory controller, said storage memory, and

said USB interface together within physical dimensions of said USB memory apparatus 700, Fig.11.

Therefore it would have been obvious to one of ordinary skill in the art, at the time the invention was made for AAPA to include in his invention said PCBA further comprises: a memory controller [0068]; a storage memory (Electrically Erasable Programmable Read Only Memory (EEPROM), in communication with said memory controller; a USB interface circuit in communication with said memory controller; and an integrated circuit package for accommodating said memory controller, said storage memory, and said USB interface together within physical dimensions of said USB memory apparatus, as taught by Ni, in order to facilitate wireless communications, as taught by Ni, [0068].

As to claims 6 – 8, 14, 15 and 16 : AAPA as modified by the teaching of Kao, discloses the USB memory apparatus having all of the claimed features as discussed above with respect to claim 1(9),

except, AAPA does not explicitly teach a LED indicator for indicating operation of said USB memory apparatus, wherein said PCBA further comprises a LED module controller for controlling said LED indicator; wherein said housing further comprises an opening for positioning said LED indicator.

Ni teaches Fig. 11 a LED indicator 770 for indicating operation of said USB memory apparatus, wherein said PCBA further comprises a LED module controller for controlling said LED indicator [0068]; wherein said housing further comprises an opening for positioning said LED indicator (opening in housing 750 shown in Fig. 11).

Therefore it would have been obvious to one of ordinary skill in the art, at the time the invention was made for AAPA to include in his invention a LED indicator for indicating operation of said USB memory apparatus, wherein said PCBA further comprises a LED module controller for controlling said LED indicator; wherein said housing further comprises an opening for positioning said LED indicator, as taught by Ni, in order to facilitate indication of the operation of said USB memory apparatus.

As to claim 18: AAPA as modified by the teaching of Kao and Ni, discloses the USB memory apparatus having all of the claimed features as discussed above with respect to claim 17,

except, AAPA does not explicitly teach a LED indicator for indicating operation of said USB memory apparatus, wherein said PCBA further comprises a LED module controller for controlling said LED indicator; wherein said housing further comprises an opening for positioning said LED indicator.

Ni teaches Fig. 11 a LED indicator 770 for indicating operation of said USB memory apparatus, wherein said PCBA further comprises a LED module controller for controlling said LED indicator [0068]; wherein said housing further comprises an opening for positioning said LED indicator (opening in housing 750 shown in Fig. 11).

Therefore it would have been obvious to one of ordinary skill in the art, at the time the invention was made for AAPA to include in his invention a LED indicator for indicating operation of said USB memory apparatus, wherein said PCBA further comprises a LED module controller for controlling said LED indicator; wherein said housing further comprises an opening for positioning said LED indicator, as taught by Ni, in order to facilitate indication of the operation of said USB memory apparatus.

### ***Relevant Art***

3. The prior art made of record and not relied upon is considered pertinent to applicant's disclosure.

Miller et al. – PGPub. No: 2008/0064272;

Chi et al. – PGPub. No: 2008/0076280;

Wu et al. – PGPub. No: 2007/0066119;

Mitsubishi – PGPub. No: 20070127223.

4. Any inquiry concerning this communication or earlier communications from the examiner should be directed to Yuriy Semenenko whose telephone number is (571) 272-6106. The examiner can normally be reached on 8:30am - 5:00pm.

If attempts to reach the examiner by telephone are unsuccessful, the examiner's supervisor, Dean A. Reichard can be reached on (571)- 272-2800 ext. 31. The fax phone number for the organization where this application or proceeding is assigned is 571-273-8300.

Information regarding the status of an application may be obtained from the Patent Application Information Retrieval (PAIR) system. Status information for published applications may be obtained from either Private PAIR or Public PAIR. Status information for unpublished applications is available through Private PAIR only. For more information about the PAIR system, see <http://pair-direct.uspto.gov>. Should you have questions on access to the Private PAIR system, contact the Electronic Business Center (EBC) at 866-217-9197 (toll-free).

/Yuriy Semenenko/  
Examiner, Art Unit 2841

/Dean A. Reichard/  
Supervisory Patent Examiner, Art  
Unit 2841

<b>Notice of References Cited</b>	Application/Control No. 11/384,371	Applicant(s)/Patent Under Reexamination CHUNG ET AL.	
	Examiner YURIY SEMENENKO	Art Unit 2841	Page 1 of 1

**U.S. PATENT DOCUMENTS**

*	Document Number Country Code-Number-Kind Code	Date MM-YYYY	Name	Classification
*	A US-2007/0127223	06-2007	Mitsuhashi, Takeshi	361/752
*	B US-2004/0087213	05-2004	KAO, CHI-LEI	439/638
*	C US-2007/0178769	08-2007	Ni, Jim	439/660
*	D US-2008/0064272	03-2008	Miller et al.	439/892
*	E US-2007/0066119	03-2007	Wu et al.	439/378
*	F US-2008/0076280	03-2008	Chi et al.	439/131
	G US-			
	H US-			
	I US-			
	J US-			
	K US-			
	L US-			
	M US-			

**FOREIGN PATENT DOCUMENTS**

*	Document Number Country Code-Number-Kind Code	Date MM-YYYY	Country	Name	Classification
	N				
	O				
	P				
	Q				
	R				
	S				
	T				

**NON-PATENT DOCUMENTS**

*	Include as applicable: Author, Title Date, Publisher, Edition or Volume, Pertinent Pages)
U	
V	
W	
X	

\*A copy of this reference is not being furnished with this Office action. (See MPEP § 707.05(a).)  
Dates in MM-YYYY format are publication dates. Classifications may be US or foreign.

<b><i>Index of Claims</i></b> 	<b>Application/Control No.</b> 11384371	<b>Applicant(s)/Patent Under Reexamination</b> CHUNG ET AL.
	<b>Examiner</b> YURIY SEMENENKO	<b>Art Unit</b> 2841

✓	<b>Rejected</b>
=	<b>Allowed</b>

-	<b>Cancelled</b>
÷	<b>Restricted</b>

N	<b>Non-Elected</b>
I	<b>Interference</b>

A	<b>Appeal</b>
O	<b>Objected</b>

Claims renumbered in the same order as presented by applicant
  CPA
  T.D.
  R.1.47

CLAIM		DATE								
Final	Original	04/09/2008								
	1	✓								
	2	✓								
	3	✓								
	4	✓								
	5	✓								
	6	✓								
	7	✓								
	8	✓								
	9	✓								
	10	✓								
	11	✓								
	12	✓								
	13	✓								
	14	✓								
	15	✓								
	16	✓								
	17	✓								
	18	✓								

<b>Search Notes</b>  	<b>Application/Control No.</b>  11384371	<b>Applicant(s)/Patent Under Reexamination</b>  CHUNG ET AL.
	<b>Examiner</b>  YURIY SEMENENKO	<b>Art Unit</b>  2841

SEARCHED			
Class	Subclass	Date	Examiner
361	737	04/09/2008	YS
439	638	04/09/2008	YS
174	255	04/09/2008	YS

SEARCH NOTES		
Search Notes	Date	Examiner
East, text, search strategy.		
See search history printout	04/09/2008	YS

INTERFERENCE SEARCH			
Class	Subclass	Date	Examiner

## EAST Search History

Ref #	Hits	Search Query	DBs	Default Operator	Plurals	Time Stamp
S1	1	11/384371	US-PGPUB; USPAT; USOCR; EPO; JPO; DERWENT; IBM_TDB	OR	ON	2008/04/08 10:59
S2	975227	"174"/\$.cls. or "361"/\$.cls. or "439"/\$.cls. or "257"/\$.cls. or "29"/\$.cls.	US-PGPUB; USPAT; USOCR; EPO; JPO; DERWENT; IBM_TDB	OR	ON	2008/04/08 11:42
S3	1006264	"174"/\$.cls. or "361"/\$.cls. or "439"/\$.cls. or "257"/\$.cls. or "29"/\$.cls. or "710"/\$.cls.	US-PGPUB; USPAT; USOCR; EPO; JPO; DERWENT; IBM_TDB	OR	ON	2008/04/08 11:43
S4	3309	S3 and (((universal with searial with bus) or USB) same memory)	US-PGPUB; USPAT; USOCR; EPO; JPO; DERWENT; IBM_TDB	OR	ON	2008/04/08 11:46
S5	353936	"174"/\$.cls. or "361"/\$.cls. or "439"/\$.cls.	US-PGPUB; USPAT; USOCR; EPO; JPO; DERWENT; IBM_TDB	OR	ON	2008/04/08 11:46
S6	828	S5 and (((universal with searial with bus) or USB) same memory)	US-PGPUB; USPAT; USOCR; EPO; JPO; DERWENT; IBM_TDB	OR	ON	2008/04/08 11:47
S7	3	S5 and (concave with prop)	US-PGPUB; USPAT; USOCR; EPO; JPO; DERWENT; IBM_TDB	OR	ON	2008/04/08 13:12
S8	2100	S5 and (prop)	US-PGPUB; USPAT; USOCR; EPO; JPO; DERWENT; IBM_TDB	OR	ON	2008/04/08 13:15



S9	2	S8 and S6	US-PGPUB; USPAT; USOCR; EPO; JPO; DERWENT; IBM_TDB	OR	ON	2008/04/08 13:16
S10	2	S8 and S4	US-PGPUB; USPAT; USOCR; EPO; JPO; DERWENT; IBM_TDB	OR	ON	2008/04/08 13:18
S11	0	JP-2005-348989-\$. did.	US-PGPUB; USPAT; USOCR; EPO; JPO; DERWENT; IBM_TDB	OR	ON	2008/04/09 07:38
S12	2	JP-2005348989-\$. did.	US-PGPUB; USPAT; USOCR; EPO; JPO; DERWENT; IBM_TDB	OR	ON	2008/04/09 07:38
S13	6	("5335145"   "5991157"   "6781846").PN.	US-PGPUB; USPAT; USOCR; EPO; JPO; DERWENT; IBM_TDB	OR	ON	2008/04/09 07:42
S14	11	("4858070"   "4955131"   "5375037"   "5437041"   "5477426"   "5548483"   "5608607"   "5659459"   "5680294"   "5725622"   "5745041").PN. OR ("6781846"). URPN.	US-PGPUB; USPAT; USOCR	OR	ON	2008/04/09 07:45
S15	85	mitsuhashi-takeshi. in.	US-PGPUB; USPAT; USOCR; EPO; JPO; DERWENT; IBM_TDB	OR	ON	2008/04/09 07:48
S16	1006264	"174"/\$.ccls. or "361"/\$.ccls. or "439"/\$.ccls. or "257"/\$.ccls. or "29"/\$.ccls. or "710"/\$.ccls.	US-PGPUB; USPAT; USOCR; EPO; JPO; DERWENT; IBM_TDB	OR	ON	2008/04/09 10:27

EAST Search History

S17	17	S16 and (((universal with searial with bus) or USB) same memory same LED same EEPROM)	US-PGPUB; USPAT; USOCR; EPO; JPO; DERWENT; IBM_TDB	OR	ON	2008/04/09 10:27
S18	0	11/972388	US-PGPUB; USPAT; USOCR; EPO; JPO; DERWENT; IBM_TDB	OR	ON	2008/04/09 11:48

4/ 9/ 2008 4:12:36 PM

C:\Documents and Settings\ysemenenko\My Documents\EAST\Workspaces\11384371.  
wsp



UNITED STATES PATENT AND TRADEMARK OFFICE

UNITED STATES DEPARTMENT OF COMMERCE  
 United States Patent and Trademark Office  
 Address: COMMISSIONER FOR PATENTS  
 P.O. Box 1450  
 Alexandria, Virginia 22313-1450  
 www.uspto.gov

BIB DATA SHEET

CONFIRMATION NO. 8664

<b>SERIAL NUMBER</b> 11/384,371	<b>FILING or 371(c) DATE</b> 03/21/2006 <b>RULE</b>	<b>CLASS</b> 235	<b>GROUP ART UNIT</b> 2841	<b>ATTORNEY DOCKET NO.</b> CHUN3098/EM		
<b>APPLICANTS</b> Tom Chung, Hsinchu, TAIWAN; Dean Huang, Hsinchu, TAIWAN; Peter Huang, Hsinchu, TAIWAN;						
** CONTINUING DATA *****						
** FOREIGN APPLICATIONS *****						
** IF REQUIRED, FOREIGN FILING LICENSE GRANTED ** * SMALL ENTITY ** 04/13/2006						
Foreign Priority claimed <input type="checkbox"/> Yes <input checked="" type="checkbox"/> No	35 USC 119(a-d) conditions met <input type="checkbox"/> Yes <input checked="" type="checkbox"/> No	<input type="checkbox"/> Met after Allowance	<b>STATE OR COUNTRY</b> TAIWAN	<b>SHEETS DRAWINGS</b> 5	<b>TOTAL CLAIMS</b> 18	<b>INDEPENDENT CLAIMS</b> 3
Verified and /YURIY SEMENENKO/ Examiner's Signature	Initials					
<b>ADDRESS</b> BACON & THOMAS, PLLC 625 SLATERS LANE FOURTH FLOOR ALEXANDRIA, VA 22314						
<b>TITLE</b> Universal Serial Bus (USB) memory apparatus						
<b>FILING FEE RECEIVED</b> 500	FEES: Authority has been given in Paper No. _____ to charge/credit DEPOSIT ACCOUNT No. _____ for following:		<input type="checkbox"/> All Fees <input type="checkbox"/> 1.16 Fees (Filing) <input type="checkbox"/> 1.17 Fees (Processing Ext. of time) <input type="checkbox"/> 1.18 Fees (Issue) <input type="checkbox"/> Other _____ <input type="checkbox"/> Credit _____			



UNITED STATES PATENT AND TRADEMARK OFFICE

UNITED STATES DEPARTMENT OF COMMERCE  
United States Patent and Trademark Office  
Address: COMMISSIONER FOR PATENTS  
P.O. Box 1450  
Alexandria, Virginia 22313-1450  
www.uspto.gov

APPLICATION NUMBER	FILING OR 371(c) DATE	FIRST NAMED APPLICANT	ATTY. DOCKET NO./TITLE
11/384,371	03/21/2006	Tom Chung	CHUN3098/EM

**CONFIRMATION NO. 8664**

23364  
BACON & THOMAS, PLLC  
625 SLATERS LANE  
FOURTH FLOOR  
ALEXANDRIA, VA22314

**Title:** Universal Serial Bus (USB) memory apparatus

**Publication No.** US-2007-0245047-A1

**Publication Date:** 10/18/2007

**NOTICE OF PUBLICATION OF APPLICATION**

The above-identified application will be electronically published as a patent application publication pursuant to 37 CFR 1.211, et seq. The patent application publication number and publication date are set forth above.

The publication may be accessed through the USPTO's publically available Searchable Databases via the Internet at [www.uspto.gov](http://www.uspto.gov). The direct link to access the publication is currently <http://www.uspto.gov/patft/>.

The publication process established by the Office does not provide for mailing a copy of the publication to applicant. A copy of the publication may be obtained from the Office upon payment of the appropriate fee set forth in 37 CFR 1.19(a)(1). Orders for copies of patent application publications are handled by the USPTO's Office of Public Records. The Office of Public Records can be reached by telephone at (703) 308-9726 or (800) 972-6382, by facsimile at (703) 305-8759, by mail addressed to the United States Patent and Trademark Office, Office of Public Records, Alexandria, VA 22313-1450 or via the Internet.

In addition, information on the status of the application, including the mailing date of Office actions and the dates of receipt of correspondence filed in the Office, may also be accessed via the Internet through the Patent Electronic Business Center at [www.uspto.gov](http://www.uspto.gov) using the public side of the Patent Application Information and Retrieval (PAIR) system. The direct link to access this status information is currently <http://pair.uspto.gov/>. Prior to publication, such status information is confidential and may only be obtained by applicant using the private side of PAIR.

Further assistance in electronically accessing the publication, or about PAIR, is available by calling the Patent Electronic Business Center at 1-866-217-9197.

---

Pre-Grant Publication Division, 703-605-4283



032106

17712 U.S. PTO

# UTILITY PATENT APPLICATION TRANSMITTAL

Address to: <b>Box PATENT APPLICATION</b> Commissioner of Patents P.O. Box 1450 Alexandria, VA 22313-1450	Attorney Docket No.	CHUN3098/EM
	First Named Inventor (or identifier)	Tom CHUNG
	Total Pages	30

Transmitted herewith is a patent application under 37 CFR 1.53(b).

Entitled: **UNIVERSAL SERIAL BUS (USB) MEMORY APPARATUS**

- 1. Submitted herewith are the following:
  - 15 pages of specification, including claims and Abstract.
  - 5 sheets of FORMAL drawings (Figs. 1-9).
  - 18 claims.
  - 1 Oath/Declaration signed by each inventor.
  - 1 Application Data Sheet.
  - 1 Assignment of the invention to Phison Electronics Corp., Chutung, Hsinchu, Taiwan  
Cover Sheet, and payment of the \$40 recordal fee.
  - 1 check in the amount of \$540 (\$500- Basic, Search & Examination Fee;  
\$40- Assignment Recordation Fee).
- 2. SMALL ENTITY STATUS IS ASSERTED pursuant to 37 CFR 1.27 for this application.
- 3. The Commissioner is authorized to credit any overpayment and charge any deficiency in any fees required under 37 CFR 1.16 and/or 1.17, to Deposit Account No. 02-0200.
- 4. Insert before the first sentence of the specification: -- This application claims the benefit of provisional application number \_\_\_\_\_ filed \_\_\_\_\_ --
- 5. Insert before the first sentence of the specification: -- This application is a Continuation-in-part of nonprovisional application number \_\_\_\_\_ filed \_\_\_\_\_ --
- 6. Other: \_\_\_\_\_

112963 U.S. PTO

11/384371



032106

The registered practitioners representing applicant(s) are J. Ernest Kenney, Reg. No. 19,179; Eugene Mar, Reg. No. 25,893; Richard E. Fichter, Reg. No. 26,382; Thomas J. Moore, Reg. No. 28,974; and Benjamin E. Urcia, Reg. No. 33,805.

THE FILING FEE IS CALCULATED AS FOLLOWS:				Basic, Search & Examination Fees:	\$1,000.00
Total Claims:	18	- 20 =	0	X \$50 =	\$0.00
Independent Claims:	3	- 3 =	0	X \$200 =	\$0.00
Correspondence Address: BACON & THOMAS, PLLC 625 Slaters Lane, 4 <sup>th</sup> Floor Alexandria, VA 22314-1176  23364 CUSTOMER NUMBER				Multiple Dependent Claim (add \$360.00):	\$0.00
				Size (\$250 for each 50 sheets in excess of 100 sheets):	\$0.00
				Subtotal:	\$1,000.00
				50% Reduction if Small Entity Status:	\$500.00
Phone: 703-683-0500	Fax: 703-683-1080		Total:		\$540.00

Date:	Name:	Signature:	Reg. No.
March 21, 2006	Eugene Mar		25,893

## UNIVERSAL SERIAL BUS (USB) MEMORY APPARATUS

### FIELD OF THE INVENTION

**[0001]** The present invention relates to a Universal Serial Bus (USB) memory apparatus, and more particularly, to a miniaturized Universal Serial Bus (USB) memory apparatus.

### BACKGROUND OF THE INVENTION

**[0002]** The capabilities of a computer are maximized by utilizing a variety of external peripheral devices that are connected to the computer. This may involve any number of peripherals. In response to computers becoming more modular, a Universal Serial Bus (USB) interface standard was jointly developed. The USB standard defines a high-speed serial data interface between a computer and add-on devices, such as keyboards, printers, scanners and secondary storage devices, including floppy disk drives, hard disk drives, and solid-state secondary storage drives. In computers that have USB compliant ports, such devices can be added or removed while the computer is powered up and running.

**[0003]** With the growing popularity of portable computing devices having USB compliant ports, such as notebook, tablet computers, and personal digital assistants (PDA), the USB ports afford on-the-go flexibility to a user of the portable computing device. That is, the user of a notebook can carry multiple external peripheral devices, and simply plug the needed external peripheral device into the portable computing device when needed.

**[0004]** Recently, flash memory cards are also being sold that contain a USB connector. Such USB-flash memory cards do not require a specialized

reader but can be plugged into a USB connector on a personal computer (PC) or other hosting device. These USB-flash memory cards can be used in place of floppy disks and are known as USB key drives, USB thumb drives, and a variety of other names. These USB-flash cards can have a capacity of more than ten floppy disks in an area not much larger than a large postage stamp.

**[0005]** Fig. 1 shows an assembly of a male slim USB connector that is integrated with a circuit-board substrate of a flash memory card according to the prior art; and Fig. 2 shows a cross-sectional view of AA-AA in Fig. 1. As shown in Figs. 1 and 2, the miniaturized USB Pen Driver includes a metallic conductive housing 11 having a plurality of orientated indentation 111, and a print circuit board assembly (PCBA) 12 for providing storing memory. Furthermore, the thickness of the print circuit board assembly (PCBA) 12 is usually insufficient, thereby making data reading and storing difficult. Therefore, in order to overcome this drawback, the height needs to be increased with the aid of another object.

**[0006]** Consequently, the miniaturized USB Pen Driver also includes a flake spacer 13 disposed between the metallic conductive housing 11 and the PCBA 12 for fitting the PCBA 12 in the metallic conductive housing 11 tightly, wherein the flake spacer 13 could be made from a metallic slice or a plastic (Mylar) slice. The flake spacer 13 is used to fill up the space between the metallic conductive housing and the PCBA 12. However, in practice, the flake spacer 13 is not easy to be fabricated into the space between the metallic conductive housing 11 and the PCBA 12. Therefore, the USB Pen Driver of the prior art could not be miniaturized effectively.

**[0007]** Fig. 3 shows an assembly of USB memory apparatus according to the prior art, and Fig. 4 shows a cross-sectional view of A-A in Fig. 3. As

shown in Figs. 3 and 4, the USB memory apparatus includes a metallic conductive housing 31 having a plurality of orientated indentation 311, and a print circuit board assembly (PCBA) 32 for providing storing memory. Similarly, the miniaturized USB memory apparatus also includes a flake spacer 33 disposed between the metallic conductive housing 31 and the PCBA 32 for fitting the PCBA 32 in the metallic conductive housing 31 tightly. Due to the flake spacer 33, the inner space of the metallic conductive housing 31 is further decreased. In practice, there is no enough space for introducing a LED indicator. If a LED indicator should be introduced into the USB memory apparatus, the prior art has to add extra space for containing the module of the LED indicator. Therefore, the USB memory apparatus of the prior art can not introduce a LED indicator without increasing extra space, and can not be miniaturized effectively

**[0008]** Although such multi-application USB memory apparatuses are technically feasible, in practice they are very difficult to implement, as demonstrated by numerous pioneering attempts ever since the invention of the miniaturized USB memory apparatus itself. It needs to provide a miniaturized Universal Serial Bus (USB) memory apparatus, which decreases the cost, simplifies the manufacturing process, is capable of introducing extra module, such as a LED indicator into the USB memory apparatus without increasing entirety volume thereof, and can rectify those drawbacks of the prior art and solve the above problems.

#### SUMMARY OF THE INVENTION

**[0009]** This paragraph extracts and compiles some features of the present invention; other features will be disclosed in the follow-up paragraph. It is



intended to cover various modifications and similar arrangements included within the spirit and scope of the appended claims, and this paragraph also is considered to refer.

**[0010]** Accordingly, the prior art is limited by the above problems. It is an object of the present invention to provide a Universal Serial Bus (USB) memory apparatus, which decreases the cost, simplifies the manufacturing process, is capable of introducing extra module, such as a LED indicator into the USB memory apparatus without increasing entirety volume thereof.

**[0011]** In accordance with an aspect of the present invention, the USB memory apparatus includes a housing having a plurality of orientated indentations and a plurality of concave props, wherein the plurality of orientated indentation facilitates the USB memory apparatus to be connected while the USB memory apparatus is inserted into a female USB socket; and a print circuit board assembly (PCBA) disposed in the housing, wherein the PCBA is fixed by means of pressing of the plurality of concave props, and a space is formed between the housing and the PCBA.

**[0012]** Preferably, the housing is made from a metallic conductive material.

**[0013]** Certainly, the plurality of orientated indentations and the plurality of concave props are integrally formed by means of punching on the housing.

**[0014]** Preferably, the PCBA further includes a memory controller; a storage memory in communication with the memory controller; a USB interface circuit in communication with the memory controller; and an integrated circuit package for accommodating the memory controller, the storage memory, and the USB interface together within physical dimensions of the USB memory apparatus.

**[0015]** Preferably, the storage memory is one of a flash memory and an Electrically Erasable Programmable Read Only Memory (EEPROM).

**[0016]** Certainly, further includes a LED indicator for indicating operation of the USB memory apparatus.

**[0017]** Preferably, the PCBA further includes a LED module controller for controlling the LED indicator.

**[0018]** Preferably, the housing further includes an opening for positioning the LED indicator.

**[0019]** According to the present invention, the USB memory apparatus includes a print circuit board assembly (PCBA); and a housing having a plurality of concave props, wherein the PCBA is disposed in the housing; the plurality of concave props protrude inward to fix the PCBA, and a space is formed between the housing and the PCBA.

**[0020]** Preferably, the housing is made from a metallic conductive material.

**[0021]** Preferably, the plurality of concave props are formed by means of punching on the housing.

**[0022]** Preferably, the PCBA further includes a memory controller; a storage memory in communication with the memory controller; a USB interface circuit in communication with the memory controller; and an integrated circuit package for accommodating the memory controller, the storage memory, and the USB interface together within physical dimensions of the USB memory apparatus.

**[0023]** Preferably, the storage memory is one of a flash memory and an Electrically Erasable Programmable Read Only Memory (EEPROM).

**[0024]** Certainly, further includes a LED indicator for indicating operation of the USB memory apparatus.

**[0025]** Preferably, the PCBA further includes a LED module controller for controlling the LED indicator.

**[0026]** Preferably, the housing further includes an opening for positioning the LED indicator.

**[0027]** In accordance with another aspect of the present invention, the USB memory apparatus includes a housing having a plurality of orientated indentations and a plurality of concave props, wherein the plurality of orientated indentation facilitates the USB memory apparatus to be connected while the USB memory apparatus is inserted into a female USB socket; an print circuit board assembly (PCBA) disposed in the housing ,wherein the PCBA is fixed by means of pressing of the plurality of concave props; and a LED module having a LED indicator disposed in the housing and a LED module controller disposed on the PCBA, wherein a space is formed between the housing and the PCBA for disposing the LED module.

**[0028]** Preferably, the housing further includes an opening for positioning the LED indicator.

**[0029]** The above objects and advantages of the present invention will become more readily apparent to those ordinarily skilled in the art after reviewing the following detailed description and accompanying drawings, in which:

## **BRIEF DESCRIPTION OF THE DRAWINGS**

[0030] Fig. 1 illustrates an assembly of a male slim USB connector that is integrated with a circuit-board substrate of a flash memory card according to the prior art.

[0031] Fig. 2 illustrates a cross-sectional view of AA-AA in Fig. 1.

[0032] Fig. 3 illustrates an assembly of USB memory apparatus according to the prior art.

[0033] Fig. 4 illustrates a cross-sectional view of A-A in Fig. 3

[0034] Fig. 5 illustrates a preferred embodiment of a USB memory apparatus according to the present invention.

[0035] Fig. 6 illustrates a cross-sectional view of A'A'-A'A' in Fig. 5.

[0036] Fig. 7 illustrates a PCBA according to the present invention.

[0037] Fig. 8 illustrates another preferred embodiment of a USB memory apparatus according to the present invention.

[0038] Fig. 9 illustrates a cross-sectional view of A'-A' in Fig. 8.

## **DETAILED DESCRIPTION OF THE PREFERRED EMBODIMENT**

[0039] The present invention discloses a Universal Serial Bus (USB) memory apparatus, and the objects and advantages of the present invention will become more readily apparent to those ordinarily skilled in the art after reviewing the following detailed description. The present invention needs not be limited to the following embodiment.

[0040] Please refer to Fig. 5 and Fig. 6. Meanwhile, Fig. 5 illustrates a preferred embodiment of a USB memory apparatus according to the present invention, and Fig. 6 illustrates a cross-sectional view of A'A'-A'A' in Fig. 5. As shown in Figs. 5 and 6, the USB memory apparatus includes a housing 51

having a plurality of orientated indentations 511 and a plurality of concave props 512, wherein the plurality of orientated indentation 511 facilitates the USB memory apparatus to be connected while the USB memory apparatus is inserted into a female USB socket (not shown); and a print circuit board assembly (PCBA) 52 disposed in the housing 51, wherein the PCBA 52 is fixed by means of pressing of the plurality of concave props 512; and there is a space 53 between the housing 51 and the PCBA 52.

**[0041]** In practice, the housing 51 is usually made from a metallic conductive material, wherein the plurality of orientated indentations 511 and the plurality of concave props 512 can be formed simultaneously by means of punching on the housing 51. In this embodiment, one end of the housing 51 is also regarded as a USB male connector, and then the height of the insertion end of the housing 51 is the same as a standard height of a standard USB male connector. Meanwhile, the plurality of orientated indentations 511 are located to engage metal springs on the USB socket (not shown), whereby the plurality of orientated indentations provide a secure fit into the USB socket when inserted. Moreover, the PCBA 52 is combined with an end base 54. Usually, the PCBA 52 should include several components. Please refer to Fig. 7. It illustrates a PCBA according to the present invention, wherein the PCBA 52 further includes a memory controller 521; a storage memory 522 in communication with the memory controller 521; a USB interface circuit 523 in communication with the memory controller 521; and an integrated circuit package 524 for maintaining the memory controller 521, the storage memory 522, and the USB interface 523 together within physical dimensions of the USB memory apparatus. Meanwhile, the storage memory 522 is one of a flash memory and an Electrically Erasable Programmable Read Only Memory

(EEPROM). Certainly, the PCBA 52 could introduce any electronic component according to the requirement. Specially, the USB memory apparatus of the present invention could introduce more components by means of using to the space 53 between the housing 51 and the PCBA 52.

[0042] Please refer to Fig. 8 and Fig. 9. Meanwhile, Fig. 8 illustrates another preferred embodiment of a USB memory apparatus according to the present invention, and Fig. 9 illustrates a cross-sectional view of A'-A' in Fig. 8. As shown in Figs. 8 and 9, the USB memory apparatus includes a housing 81 having a plurality of orientated indentations 811 and a plurality of concave props 812, wherein the plurality of orientated indentation 811 (which is located to engage metal springs on the female USB socket) facilitates the USB memory apparatus to be connected while the USB memory apparatus is inserted into a female USB socket; a print circuit board assembly (PCBA) 82 disposed in the housing 81, wherein the PCBA 82 is fixed by means of pressing of the plurality of concave prop 812 (Please refer to Fig. 6, marked as 512); and a LED module having a LED indicator 841 disposed in the housing 81 and a LED module controller 842 disposed on the PCBA 82, wherein there is a space 83 between the housing 81 and the PCBA 82 for facilitating the LED module to be disposed.

[0043] In practice, the housing 81 could further include an opening 85 for facilitating the LED indicator 841 to emit light. The housing 81 is usually made from a metallic conductive material, wherein the plurality of orientated indentations 811, the plurality of concave props 812, and the opening 85 are unitary. Similar to the above descriptions, one end of the housing 81 is also regarded as a USB male connector, and then the height of the insertion end of the housing 81 is the same as a standard height of a standard USB male

connector. Meanwhile, the plurality of orientated indentations 811 provide a secure fit into the USB socket when inserted. Actually, the housing 81 could also be regarded as an entire case of the USB memory apparatus, thereby decreasing the entire volume of the USB memory apparatus. Similarly, the PCBA 82, equal to Fig. 7, marked 52, could include a memory controller 521; a storage memory 522 in communication with the memory controller 521; a USB interface circuit 523 in communication with the memory controller 521; and an integrated circuit package 524 for maintaining the memory controller 521, the storage memory 522, and the USB interface 523 together within physical dimensions of the USB memory apparatus, wherein the storage memory 522 is a flash memory or an Electrically Erasable Programmable Read Only Memory (EEPROM). Certainly, the PCBA 82 could introduce any electronic component according to the requirement. In this embodiment, the USB memory apparatus further introduces a LED module without increasing entirety volume thereof. In accordance with the aspect of the present invention, the USB memory apparatus of the present invention could introduce more components by means of using to the space 83 between the housing 81 and the PCBA 82.

**[0044]** In conclusion, the present invention provides a Universal Serial Bus (USB) memory apparatus, which decreases the cost and increases the yield because the flake spacer is not introduced. Moreover, it simplifies the manufacturing process because the PCBA could be propped up by punched concave props instead of uncontrollable flake spacer. Additionally, the USB memory apparatus of the present invention is capable of introducing extra module, such as a LED indicator into the USB memory apparatus without increasing entirety volume thereof by means of using to the space between the

housing and the PCBA. On the other hand, the housing could also be regarded as an entire case of the USB memory apparatus directly. Thus, the USB memory apparatus of the present invention can be miniaturized effectively. Certainly, the USB memory apparatus of the present invention could further include a decorated case covering the housing according to the multi-type design. Meanwhile the prior art fail to disclose that. Accordingly, the present invention possesses many outstanding characteristics, effectively improves upon the drawbacks associated with the prior art in practice and application, produces practical and reliable products, bears novelty, and adds to economical utility value. Therefore, the present invention exhibits a great industrial value.

**[0045]** While the invention has been described in terms of what is presently considered to be the most practical and preferred embodiments, it is to be understood that the invention needs not be limited to the disclosed embodiment. On the contrary, it is intended to cover various modifications and similar arrangements included within the spirit and scope of the appended claims, which are to be accorded with the broadest interpretation so as to encompass all such modifications and similar structures.



WHAT IS CLAIMED IS:

1. A Universal Serial Bus (USB) memory apparatus, comprising:
  - a housing having a plurality of orientated indentations and a plurality of concave props, wherein said plurality of orientated indentation facilitates said USB memory apparatus to be connected while said USB memory apparatus is inserted into a female USB socket; and
  - a print circuit board assembly (PCBA) disposed in said housing, wherein said PCBA is fixed by means of pressing of said plurality of concave props, and a space is formed between said housing and said PCBA.
2. The USB memory apparatus according to claim 1, wherein said housing is made from a metallic conductive material.
3. The USB memory apparatus according to claim 1, wherein said plurality of orientated indentations and said plurality of concave props are integrally formed by means of punching on said housing.
4. The USB memory apparatus according to claim 1, wherein said PCBA further comprises:
  - a memory controller;
  - a storage memory in communication with said memory controller;
  - a USB interface circuit in communication with said memory controller;and
  - an integrated circuit package for accommodating said memory controller, said storage memory, and said USB interface together within physical dimensions of said USB memory apparatus.
5. The USB memory apparatus according to claim 4, wherein said storage memory is one of a flash memory and an Electrically Erasable Programmable Read Only Memory (EEPROM).

6. The USB memory apparatus according to claim 1, further comprising a LED indicator for indicating operation of said USB memory apparatus.
7. The USB memory apparatus according to claim 6, wherein said PCBA further comprises a LED module controller for controlling said LED indicator.
8. The USB memory apparatus according to claim 6, wherein said housing further comprises an opening for positioning said LED indicator.
9. A USB memory apparatus, comprising:
  - a print circuit board assembly (PCBA); and
  - a housing having a plurality of concave props, wherein said PCBA is disposed in said housing; said plurality of concave props protrude inward to fix said PCBA, and a space is formed between said housing and said PCBA.
10. The USB memory apparatus according to claim 9, wherein said housing is made from a metallic conductive material.
11. The USB memory apparatus according to claim 9, wherein said plurality of concave props are formed by means of punching on said housing.
12. The USB memory apparatus according to claim 9, wherein said PCBA further comprises:
  - a memory controller;
  - a storage memory in communication with said memory controller;
  - a USB interface circuit in communication with said memory controller;and
  - an integrated circuit package for accommodating said memory controller, said storage memory, and said USB interface together within physical dimensions of said USB memory apparatus.
13. The USB memory apparatus according to claim 12, wherein said storage memory is one of a flash memory and an Electrically Erasable Programmable

Read Only Memory (EEPROM).

14. The USB memory apparatus according to claim 9, further comprising a LED indicator for indicating operation of said USB memory apparatus.

15. The USB memory apparatus according to claim 14, wherein said PCBA further comprises a LED module controller for controlling said LED indicator.

16. The USB memory apparatus according to claim 14, wherein said housing further comprises an opening for positioning said LED indicator.

17. A USB memory apparatus, comprising:

a housing having a plurality of orientated indentations and a plurality of concave props, wherein said plurality of orientated indentation facilitates said USB memory apparatus to be connected while said USB memory apparatus is inserted into a female USB socket;

a print circuit board assembly (PCBA) disposed in said housing ,wherein said PCBA is fixed by means of pressing of said plurality of concave props;  
and

a LED module having a LED indicator disposed in said housing and a LED module controller disposed on said PCBA, wherein a space is formed between said housing and said PCBA for disposing said LED module.

18. The USB memory apparatus according to claim 17, wherein said housing further comprises an opening for positioning said LED indicator.

## UNIVERSAL SERIAL BUS (USB) MEMORY APPARATUS

### ABSTRACT OF THE DISCLOSURE

A universal serial bus (USB) memory apparatus is disclosed. The USB memory apparatus includes a housing having a plurality of orientated indentations and a plurality of concave props, wherein the plurality of orientated indentation facilitates the USB memory apparatus to be connected while the USB memory apparatus is inserted into a female USB socket; a print circuit board assembly (PCBA) disposed in the housing, wherein the PCBA is fixed by means of pressing of the plurality of concave props; and a LED module having a LED indicator disposed in the housing and a LED module controller disposed on the PCBA, wherein a space is formed between the housing and the PCBA for disposing the LED module.

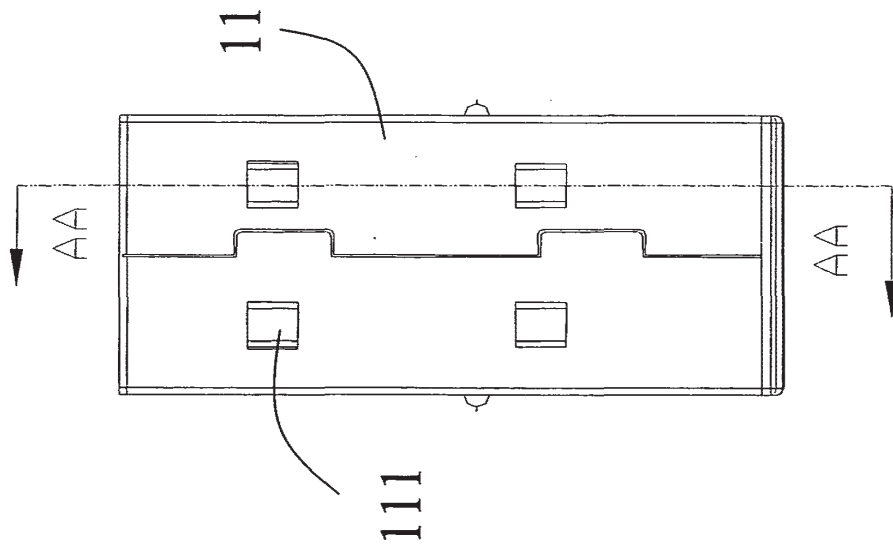

Fig. 1  
(Prior Art)

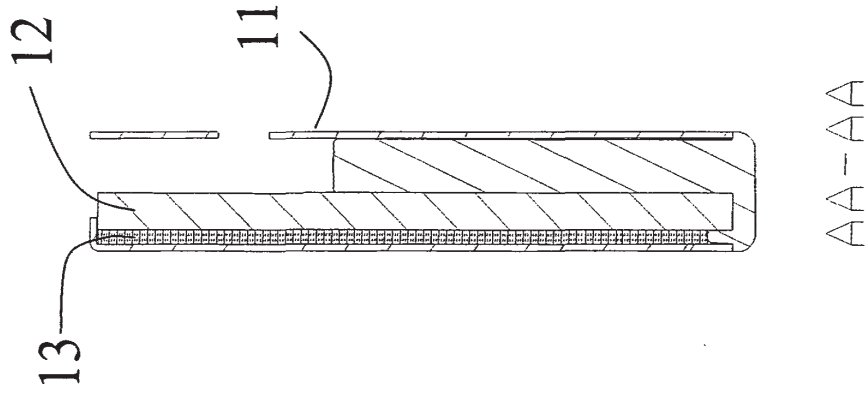

Fig. 2  
(Prior Art)

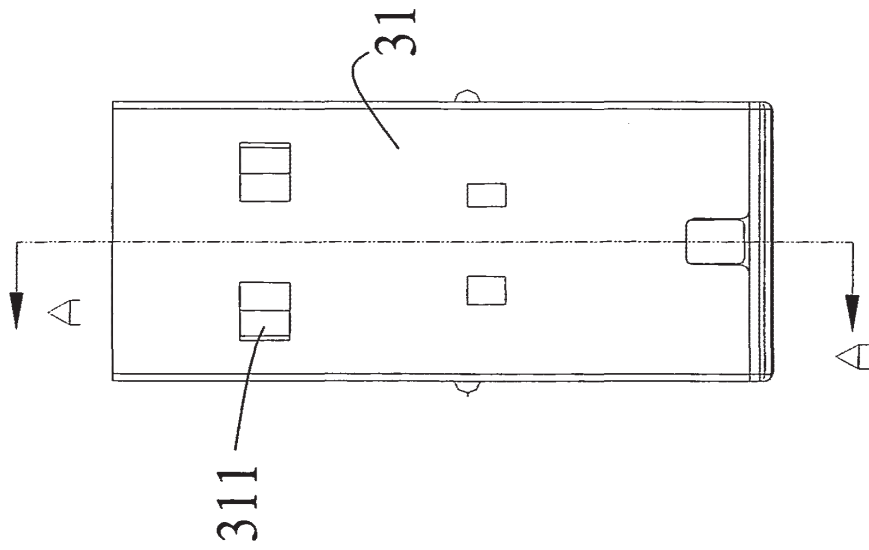
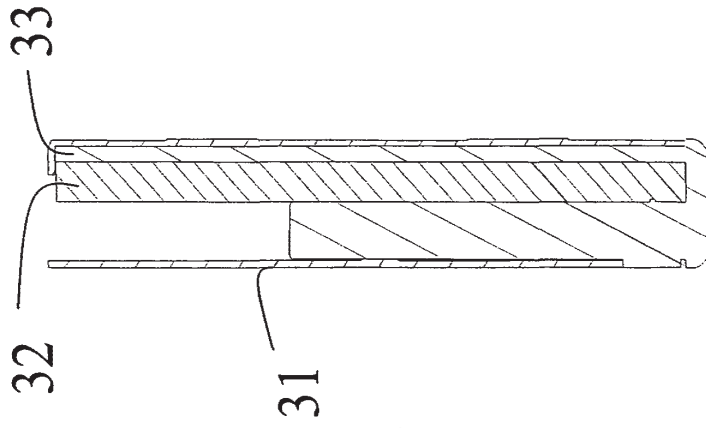

Fig. 3  
(Prior Art)



A-A

Fig. 4  
(Prior Art)

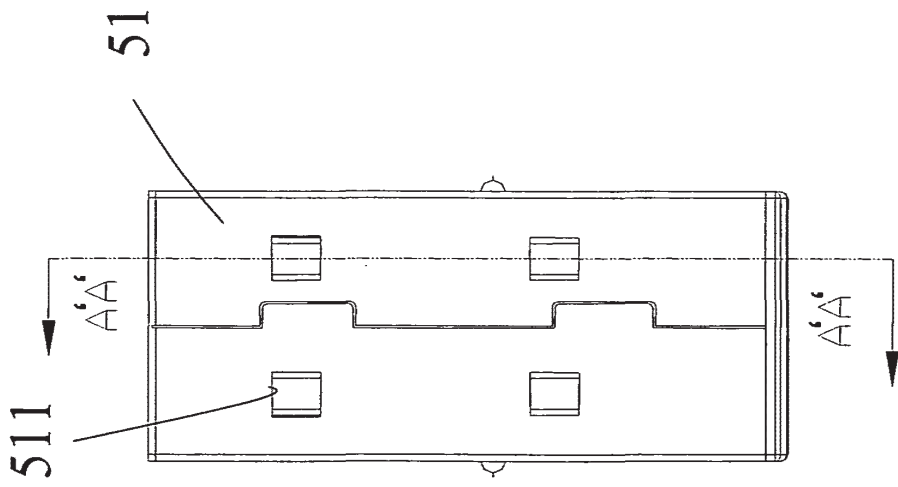

Fig. 5

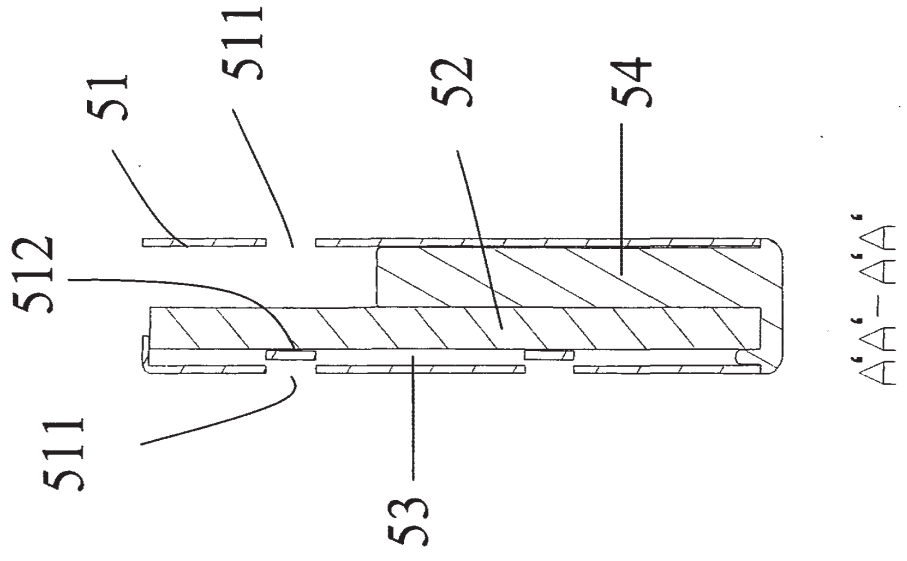

Fig. 6

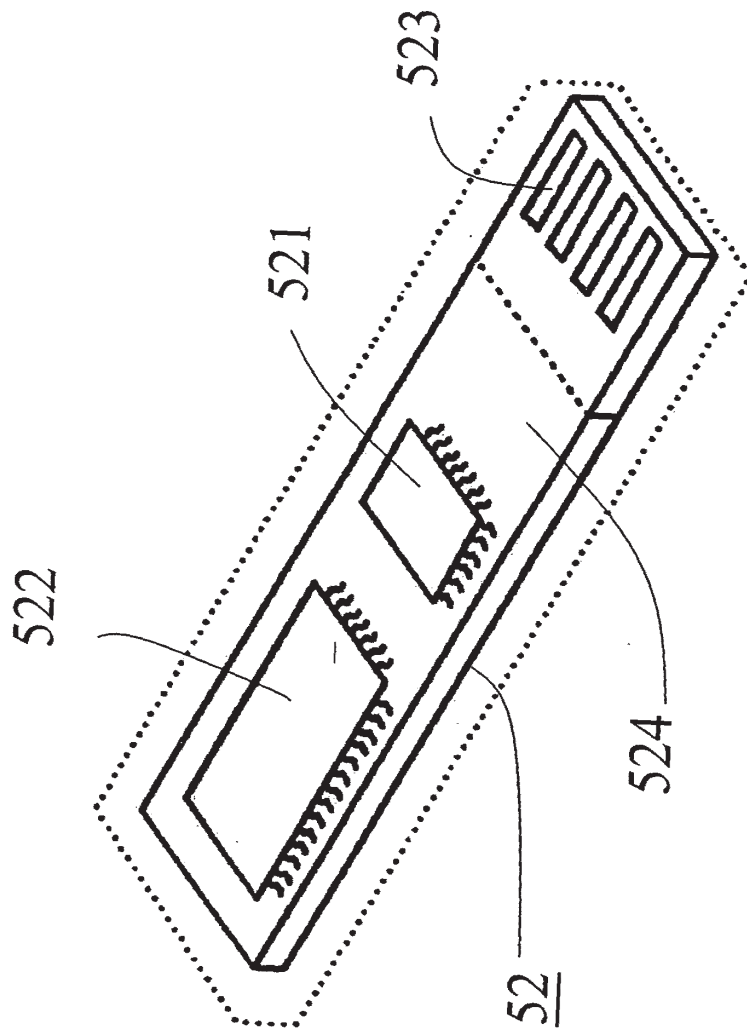

Fig. 7



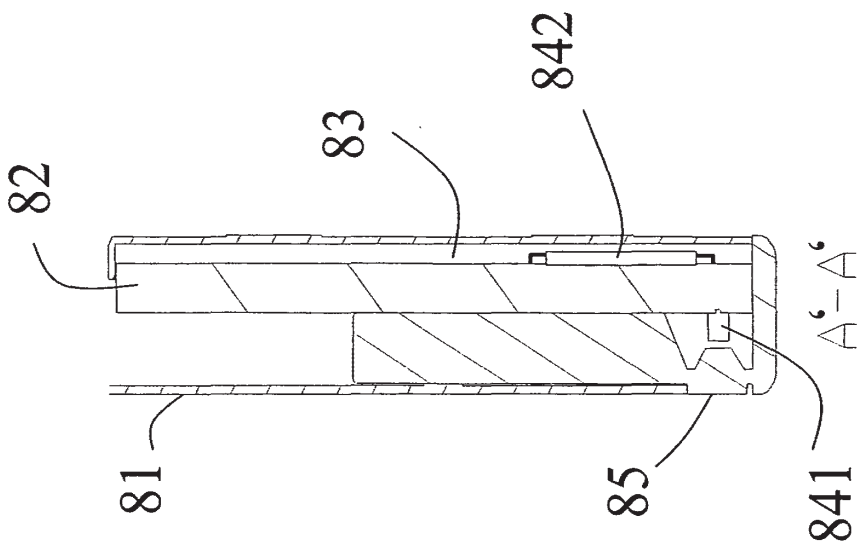

Fig. 9

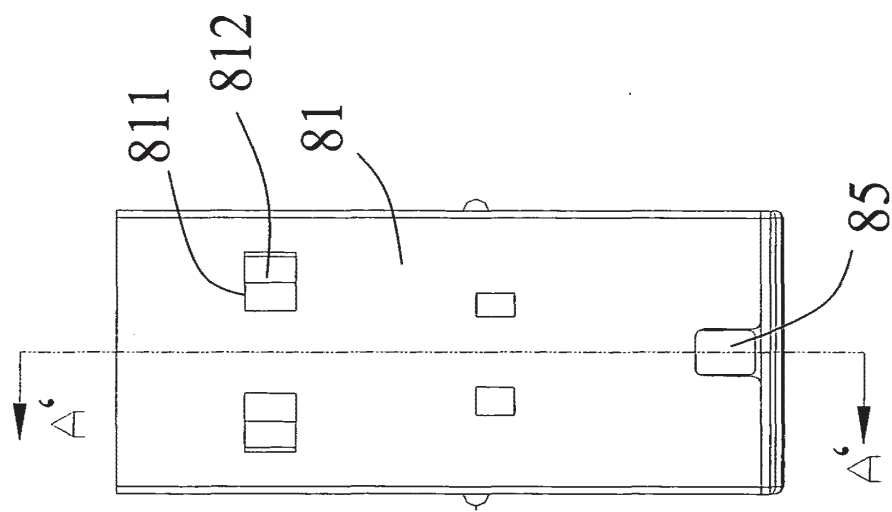

Fig. 8

ATTORNEY/DOCKET NO:

**DECLARATION FOR PATENT APPLICATION AND APPOINTMENT OF ATTORNEY**

As a below named inventor, I hereby declare that I believe that I am the original, first and sole inventor (if only one name is listed below) or an original, first and joint inventor (if plural names are listed below) of the subject matter which is claimed and for which a patent is sought on the invention (Design, if applicable) entitled:

Title: **Universal Serial Bus (USB) Memory Apparatus**

the specification of which (check at least one of the first three boxes below, as applicable):

<input checked="" type="checkbox"/>	is attached hereto.	
<input type="checkbox"/>	was filed on (day-month-year)	as U.S. Application Number
<input type="checkbox"/>	was filed on (day-month-year)	as PCT Application Number
<input type="checkbox"/>	and (if applicable) was amended on (day-month-year)	

I hereby state that I have reviewed and understand the contents of the above-identified specification, including the claims, as amended by any amendment(s) referred to above. I acknowledge the duty to disclose information which is material to patentability as defined in Title 37, Code of Federal Regulations, §1.56.

I hereby claim foreign priority benefits under Title 35, United States Code §119 of any foreign application(s) for patent or inventor's certificate listed on the Application Data Sheet, and have also identified on the Application Data Sheet any foreign application for patent or inventor's certificate having a filing date before that of each application on which priority is claimed.

I hereby claim the benefit under Title 35 U.S. Code §119(e) of any U.S. provisional applications listed on the Application Data Sheet.

I hereby claim the benefit under Title 35, United States Code, §120 of any United States application(s) or PCT international application(s) designating The United States of America listed on the Application Data Sheet, and, insofar as the subject matter of each of the claims of this application is not disclosed in that/those prior application(s) in the manner provided by the first paragraph of Title 35, United States Code, §112, I acknowledge the duty to disclose information which is material to patentability as defined in Title 37, Code of Federal Regulations, §1.56 which became available between the filing date of the prior application(s) and the national or PCT international filing date of this application.

I hereby declare that all statements made herein of my own knowledge are true and that all statements made on information and belief are believed to be true; and further that these statements were made with the knowledge that willful false statements and the like so made are punishable by fine or imprisonment, or both, under section 1001 of title 18 of the United States Code and that such willful false statements may jeopardize the validity of the application or any patent issued thereon.

POWER OF ATTORNEY: I (We) hereby appoint as my (our) attorneys, with full powers of substitution and revocation, to prosecute this application including the submission and amendment of an application data sheet (37 CFR §1.76), to take instructions from my (our) agent, to receive all communications at the address stated on the Application Data Sheet, and transact all business in the Patent and Trademark Office connected therewith: J. Ernest Kenney, Reg. No. 19,179; Eugene Mar, Reg. No. 25,893; Richard E. Fichter, Reg. No. 26,382; Thomas J. Moore, Reg. No. 28,974; Eric S. Spector, Reg. No. 22,495; Felix J. D'Ambrosio, Reg. No. 25,721; Benjamin E. Urcia, Reg. No. 33,805; and Chung C. Chen, Reg. No. 31,725; each of Bacon & Thomas, PLLC, and

Full Name of First or Sole Inventor Tom Chung	Post Office Address 2F, RiteKom Bldg. No.669, Sec.4, Chung Hsing Rd., Chutung, Hsinchu, Taiwan 310, R.O.C.
Citizenship ROC, Taiwan	Residence (city, and either state or foreign country, MPEP §605.02) 2F, RiteKom Bldg. No.669, Sec.4, Chung Hsing Rd., Chutung, Hsinchu, Taiwan 310, R.O.C.
Date Mar. 16, 2006	Signature <i>Tom Chung</i>

See following page(s) for additional joint inventors.

**BEST AVAILABLE COPY**

ATTORNEY/DOCKET NO:

**SUPPLEMENTAL PAGE FOR A  
DECLARATION FOR PATENT APPLICATION AND APPOINTMENT OF ATTORNEY**

Full Name of Joint Inventor Dean Huang	Post Office Address 2F, RiteKom Bldg. No.669, Sec.4, Chung Hsing Rd., Chutung, Hsinchu, Taiwan 310, R.O.C.
Citizenship ROC, Taiwan	Residence (city, and either state or foreign country, MPEP §605.02) 2F, RiteKom Bldg. No.669, Sec.4, Chung Hsing Rd., Chutung, Hsinchu, Taiwan 310, R.O.C.
Date Mar. 16, 2006	Signature <i>Dean Huang</i>

Full Name of Joint Inventor Peter Huang	Post Office Address 2F, RiteKom Bldg. No.669, Sec.4, Chung Hsing Rd., Chutung, Hsinchu, Taiwan 310, R.O.C.
Citizenship ROC, Taiwan	Residence (city, and either state or foreign country, MPEP §605.02) 2F, RiteKom Bldg. No.669, Sec.4, Chung Hsing Rd., Chutung, Hsinchu, Taiwan 310, R.O.C.
Date Mar. 16, 2006	Signature <i>Peter Huang</i>

Full Name of Joint Inventor	Post Office Address
Citizenship	Residence (city, and either state or foreign country, MPEP §605.02)
Date	Signature

Full Name of Joint Inventor	Post Office Address
Citizenship	Residence (city, and either state or foreign country, MPEP §605.02)
Date	Signature

See following page(s) for additional joint inventors.

(09Jan2004)

**BEST AVAILABLE COPY**

PATENT APPLICATION SERIAL NO. \_\_\_\_\_

U.S. DEPARTMENT OF COMMERCE  
PATENT AND TRADEMARK OFFICE  
FEE RECORD SHEET

03/22/2006 FFAAEIA 0000063 11384371

01 FC:2011	150.00 OP
02 FC:2111	250.00 OP
03 FC:2311	100.00 OP

PTO-1556  
(5/87)

Under the Paperwork Reduction Act of 1995, no persons are required to respond to a collection of information unless it displays a valid OMB control number.

**PATENT APPLICATION FEE DETERMINATION RECORD**  
 Substitute for Form PTO-875 Effective December 8, 2004

Application or Docket Number  
 1384371

**APPLICATION AS FILED - PART I**

(Column 1)		(Column 2)	SMALL ENTITY		OR	OTHER THAN SMALL ENTITY	
FOR	NUMBER FILED	NUMBER EXTRA	RATE (\$)	FEE (\$)		RATE (\$)	FEE (\$)
BASIC FEE (37 CFR 1.16(a), (b), or (c))	N/A	N/A	N/A	150.00		N/A	300.00
SEARCH FEE (37 CFR 1.16(b), (f), or (m))	N/A	N/A	N/A	\$250		N/A	\$500
EXAMINATION FEE (37 CFR 1.16(a), (e), or (g))	N/A	N/A	N/A	\$100		N/A	\$200
TOTAL CLAIMS (37 CFR 1.16(f))	18	minus 20 =	X\$ 25 =		OR	X\$50 =	
INDEPENDENT CLAIMS (37 CFR 1.16(h))	3	minus 3 =	X100 =			X200 =	
APPLICATION SIZE FEE (37 CFR 1.16(e))	If the specification and drawings exceed 100 sheets of paper, the application size fee due is \$250 (\$125 for small entity) for each additional 50 sheets or fraction thereof. See 35 U.S.C. 41(a)(1)(G) and 37 CFR 1.16(s).						
MULTIPLE DEPENDENT CLAIM PRESENT (37 CFR 1.16(i))			+180=			+360=	
* If the difference in column 1 is less than zero, enter "0" in column 2.			TOTAL	500		TOTAL	

**APPLICATION AS AMENDED - PART II**

AMENDMENT A	(Column 1)	(Column 2)	(Column 3)	SMALL ENTITY		OR	OTHER THAN SMALL ENTITY	
	CLAIMS REMAINING AFTER AMENDMENT	HIGHEST NUMBER PREVIOUSLY PAID FOR	PRESENT EXTRA	RATE (\$)	ADDITIONAL FEE (\$)		RATE (\$)	ADDITIONAL FEE (\$)
Total (37 CFR 1.16(j))		Minus **	=	X\$ 25 =		OR	X\$50 =	
Independent (37 CFR 1.16(j))		Minus ***	=	X100 =		OR	X200 =	
Application Size Fee (37 CFR 1.16(s))						OR		
FIRST PRESENTATION OF MULTIPLE DEPENDENT CLAIM (37 CFR 1.16(i))				+180=		OR	+360=	
				TOTAL ADD'L FEE		OR	TOTAL ADD'L FEE	

AMENDMENT B	(Column 1)	(Column 2)	(Column 3)	SMALL ENTITY		OR	OTHER THAN SMALL ENTITY	
	CLAIMS REMAINING AFTER AMENDMENT	HIGHEST NUMBER PREVIOUSLY PAID FOR	PRESENT EXTRA	RATE (\$)	ADDITIONAL FEE (\$)		RATE (\$)	ADDITIONAL FEE (\$)
Total (37 CFR 1.16(j))		Minus **	=	X\$ 25 =		OR	X\$50 =	
Independent (37 CFR 1.16(j))		Minus ***	=	X100 =		OR	X200 =	
Application Size Fee (37 CFR 1.16(s))						OR		
FIRST PRESENTATION OF MULTIPLE DEPENDENT CLAIM (37 CFR 1.16(i))				+180=		OR	+360=	
				TOTAL ADD'L FEE		OR	TOTAL ADD'L FEE	

- \* If the entry in column 1 is less than the entry in column 2, write "0" in column 3.
- \*\* If the "Highest Number Previously Paid For" IN THIS SPACE is less than 20, enter "20".
- \*\*\* If the "Highest Number Previously Paid For" IN THIS SPACE is less than 3, enter "3".

The "Highest Number Previously Paid For" (Total or Independent) is the highest number found in the appropriate box in column 1.

This collection of information is required by 37 CFR 1.16. The information is required to obtain or retain a benefit by the public which is to file (and by the USPTO to process) an application. Confidentiality is governed by 35 U.S.C. 122 and 37 CFR 1.14. This collection is estimated to take 12 minutes to complete, including gathering, preparing, and submitting the completed application form to the USPTO. Time will vary depending upon the individual case. Any comments on the amount of time you require to complete this form and/or suggestions for reducing this burden, should be sent to the Chief Information Officer, U.S. Patent and Trademark Office, U.S. Department of Commerce, P.O. Box 1450, Alexandria, VA 22313-1450. DO NOT SEND FEES OR COMPLETED FORMS TO THIS ADDRESS. SEND TO: Commissioner for Patents, P.O. Box 1450, Alexandria, VA 22313-1450.

If you need assistance in completing the form, call 1-800-PTO-9199 and select option 2.

Application Data Sheet  
Application Information

Application type::	Regular
Subject matter::	Utility
CD-ROM or CD-R::	None
Number of CD disks::	0
Number of copies of CDs::	0
Sequence submission?::	No
Computer readable form (CRF)?::	No
Number of copies of CRF::	0
Title::	UNIVERSAL SERIAL BUS (USB) MEMORY APPARATUS
Attorney docket number::	CHUN3098/EM
Request for early publication?::	No
Request for non-publication?::	No
Suggested drawing figure::	6
Total drawing sheets::	5
Small entity?::	Yes

## Applicant Information

Applicant authority type::	Inventor(First)
Primary citizenship country::	Taiwan, R.O.C.
Status:	Full capacity
Given name::	Tom
Middle name::	
Family name::	Chung
Name suffix::	No
City of Residence::	Hsinchu
State or province of residence::	N/A

1052105

Country of residence:: Taiwan, R.O.C.  
Street of mailing address:: 2F, RiteKom Bldg., No.669,  
Sec.4, Chung Hsing Rd.,  
Chutung,  
City of mailing address:: Hsinchu  
State or province of mailing  
address:: N/A  
Country of mailing address:: Taiwan, R.O.C.  
Postal or zip code of mailing  
address:: 310

Applicant authority type:: Inventor(Second)  
Primary citizenship country:: Taiwan, R.O.C.  
Status: Full capacity  
Given name:: Dean  
Middle name::  
Family name:: Huang  
Name suffix:: No  
City of Residence:: Hsinchu  
State or province of residence:: N/A  
Country of residence:: Taiwan, R.O.C.  
Street of mailing address:: 2F, RiteKom Bldg., No.669,  
Sec.4, Chung Hsing Rd.,  
Chutung,  
City of mailing address:: Hsinchu  
State or province of mailing  
address:: N/A  
Country of mailing address:: Taiwan, R.O.C.  
Postal or zip code of mailing  
address:: 310

Applicant authority type:: Inventor(Third)

Primary citizenship country:: Taiwan, R.O.C.  
 Status: Full capacity  
 Given name:: Peter  
 Middle name::  
 Family name:: Huang  
 Name suffix:: No  
 City of Residence:: Hsinchu  
 State or province of residence:: N/A  
 Country of residence:: Taiwan, R.O.C.  
 Street of mailing address:: 2F, RiteKom Bldg., No.669,  
 Sec.4, Chung Hsing Rd.,  
 Chutung,  
 City of mailing address:: Hsinchu  
 State or province of mailing  
 address:: N/A  
 Country of mailing address:: Taiwan, R.O.C.  
 Postal or zip code of mailing  
 address:: 310

## Correspondence Information

Correspondence customer number:: 23364  
 Phone number:: 703-683-0500  
 Fax number:: 703-683-1080  
 E-mail address: [mail@baconthomas.com](mailto:mail@baconthomas.com)

## Representative Information

Representative customer number:: 23364



Domestic Priority Information			
Application::	Continuity Type::	Parent Application::	Parent Filing Date::
This application	An application claiming benefit under 35 USC 119(e)		
This application	National stage of		
This application	Continuation of		

Foreign Priority Information			
Country::	Application number::	Filing Date::	Priority claimed::
			No

## Assignee Information

Assignee name::Phison Electronics Corp.

Street of mailing address::2F, RiteKom Bldg., No669, Sec.4,  
Chung Hsing Rd., Chutung,

City of mailing address::Hsinchu

State or province of mailing address::No

Country of mailing address::Taiwan, R.O.C.

Postal or zip code of mailing address::310