

## (12) Unexamined Patent Application Publication (A)

(19) Japan Patent Office (JP)

(11) Unexamined Patent Application Publication No.

H01-197145

(43) Publication Date: December 17, 1993

(51) Intl. Classification<sup>4</sup>: ID Code: Internal File No.:

B60R 16/02

R-7443-3D

G01M 17/00

Z-6960-2G

Examination Requested: No Number of Claims: 1 (6 Pages Total)

(54) Title of Invention: FAILURE DIAGNOSIS APPARATUS FOR VEHICLE

(21) Patent Application No.: S63-20004

(22) Filing Date: January 30, 1988

(72) Inventor: Toshihiro ISHIHARA c/o Mazda Motor Corporation, 3-1 Shinchi, Fuchu-cho, Aki-gun, Hiroshima Prefecture

(72) Inventor: Haruhiro HIRANO c/o Mazda Motor Corporation, 3-1 Shinchi, Fuchu-cho, Aki-gun, Hiroshima Prefecture

(72) Inventor: Masao HIDESHIMA c/o Mazda Motor Corporation, 3-1 Shinchi, Fuchu-cho, Aki-gun, Hiroshima Prefecture

(72) Inventor: Satoru KAWAZOE c/o Mazda Motor Corporation, 3-1 Shinchi, Fuchu-cho, Aki-gun, Hiroshima Prefecture

(71) Applicant: Mazda Motor Corporation 3-1 Shinchi, Fuchu-cho, Aki-gun, Hiroshima Prefecture

(74) Agent: Masaaki FUKUOKA, Patent Agent

## Specification

## 1. Title of Invention

Failure Diagnosis Apparatus for Vehicle

## 2. Claim

(1) A failure diagnosis apparatus for a vehicle including a failure detection unit that detects a failure of an on-board device and a transmitting unit that transmits, at an occurrence of the failure, an output signal from the failure detection unit to a failure diagnosis station outside of the vehicle, the apparatus comprising: a significance determination unit that is provided in the failure diagnosis station to categorize the failure detected by the failure detection unit into failure with high significance and failure with low significance; and a display control unit that displays only the failure that has been categorized as failure with high significance by the determination unit on a display device provided on the vehicle.

## 3. [Detailed Description of the Invention]

## [Industrial Field of Application]

The present invention relates to a failure diagnosis apparatus for a vehicle, especially a failure diagnosis apparatus that is configured to follow, when a failure occurs, an instruction from a failure diagnosis station outside of the vehicle to display only those with high significance on a display device inside of the

## [Prior Art]

In recent years, much progress on mobile communication technology has led to the development of such failure diagnosis apparatus for automobiles as disclosed in Japanese Patent Publication No. JP-A-61-89114, for example. The diagnosis apparatus disclosed in this patent publication is configured such that a microcomputer with memory is mounted in the relevant automobile, and it compares signal data from sensors or actuators of various control systems provided in the automobile with data saved in the memory of the microcomputer to predict the occurrence of a failure, and, when the occurrence of a failure is predicted, a failure warning is displayed on a failure warning display device disposed in the automobile, while the failure information is transmitted to a failure diagnosis computer of a service company using a telephone line of an automobile telephone provided in the automobile so that the computer performs a failure diagnosis. With such a configuration, failure diagnosis of the automobile is performed quickly.

## [Problems to be Solved by the Invention]

The failure diagnosis apparatus disclosed in the above patent publication displays all failures on the warning display device in the vehicle regardless of significance of the failure. In such a case, the number of displayed failure warnings increases and may cause anxiety for a person on board, for example, which may lead to a loss of trust in the automobile, or the person on board may become too familiar with the displayed failure warnings, which may cause the highly significant warnings displayed to be taken lightly and disregarded.

An objective of the present invention is to provide a failure diagnosis apparatus for a vehicle that transmits to a failure diagnosis station outside the vehicle all data related to a failure and performs the required failure diagnosis, while displaying only failures as minimally required on the display device provided in the automobile, so that the apparatus does not lead to a loss of trust by causing anxiety for the person on board, or lead to disregarding highly significant failures due to the person on board becoming too familiar with displayed failures.

[Means for Solving the Problems]

The failure diagnosis apparatus according to the present invention is configured as follows in order to meet the objective above.

The configuration, which has a failure detection unit that detects a failure of an on-board device and a transmitting unit that transmits, at an occurrence of the failure, an output signal from the failure detection unit to a failure diagnosis station outside the vehicle, includes a significance determination unit that is provided in the failure diagnosis station and that categorizes the failure detected by the on-board failure detection unit and transmitted by the transmitting unit into failure with high significance and failure with low significance, and a display control unit that displays only the failure that has been categorized as failure with high significance by the determination unit on a display device disposed in the vehicle.

[Operation]

With the above configuration, regardless of whether the failure of the on-board device is high or low in significance, all data is automatically transmitted to the failure diagnosis station outside the vehicle and significance of the failure is determined in the failure diagnosis station. Then, especially only failures that

have been determined to be high in significance will be displayed on the display device provided in the vehicle. In other words, failures displayed by the display device provided in the vehicle will be limited to those as minimally required, and hence will not cause anxiety for the person on board or create a sense of distrust due to frequently displayed failures. Also, failures with high significance will be definitely reported to the person on board, and hence such failures will not be disregarded. [Example]

Below, the present invention will be described based on an example.

Firstly, an outline of a failure diagnosis apparatus for a vehicle according to the present embodiment is described with reference to Fig. 1. The failure diagnosis apparatus 1 is configured to include an on-board apparatus 2 and a failure diagnosis station 3 that is outside of vehicle. The on-board apparatus 2 is configured to include a control unit 4 that controls various devices or systems on board and detects failures thereof, a display apparatus 5 that is connected to the control unit 4, a communication control unit 6 that controls the communication between the control unit 4 and the failure diagnosis station 3 outside the vehicle, and an antenna 7 that transmits and receives a communication signal to/from the unit 6. The failure diagnosis station 3 outside the vehicle is configured to include an antenna 8 that transmits and receives the above communication signal to/from the vehicle, a communication control unit 9 that is connected to the antenna 8 and controls the communication to/from the on-board apparatus 2, and a failure diagnosis unit 10 that performs failure diagnosis based on a signal received by the unit 9.

Next, the control unit 4 in the above on-board apparatus 2 is described with reference to Fig. 2.

The control unit 4 controls an automatic transmission mounted in the vehicle. To the unit 4 are connected a vehicle speed sensor 11 that detects vehicle speed, a throttle sensor 12 that detects the degree of throttle opening of the engine, a turbine sensor 13 that detects turbine rotational frequency of a torque converter, and an idle switch 14 that detects idle status of the engine, and output signals 11a, 12a, 13a, and 14a from these sensors 11, 12, 13, and 14 are input to a computer 16 in the control unit 4 via an input processing circuit 15.

The computer 16 is configured to include a control section 16a and a failure detection section 16b, and is provided with a memory 17 (RAM). Based on input signals 11a to 14a from each of the above sensors 11 to 14 and a predetermined program saved in the memory 17, the control section 16a outputs control signals 18a to 20a via an output processing circuit 21 to a first transmission solenoid 18, a second transmission solenoid 19, and a solenoid for lock-up 20, thereby controlling operation of the automatic transmission. The failure detection section 16b determines whether or not abnormality exists in the input signals 11a to 14a from each of the above sensors 11 to 14 and the control signals 18a to 20a in light of data or a program saved in the memory 17 to detect the occurrence of a failure in the automatic transmission or its control system. For a predetermined abnormality, a warning lamp 22 is turned on via the output processing circuit 21 at the time of its occurrence.

The control unit 4 is further provided with a transmitted-received data processing circuit 23 and a display selection circuit 24 in addition to the configuration described above. The transmitted-received data processing circuit 23 exchanges data between the control unit 4 and the communication control unit 6, and the display selection circuit 24 controls the display apparatus 5 to selectively display diagnosis data from the failure diagnosis station 3, which is described later.

The communication control unit 6 is configured to include a receiving circuit 25 that receives a diagnosis data signal from the failure diagnosis station 3 via the antenna 7, a received data demodulation circuit 26 that converts the signal received by the receiving circuit 25 into an easily-processable signal, a received data buffer 27 that stores the demodulated signal, a transmitted data buffer 28 that stores a failure data signal output from the control unit 4, a transmitted data modulation circuit 29 that converts the data signal into an easily-transmittable signal, and a transmitting circuit 30 that transmits the modulated failure data signal to the failure diagnosis station 3 via the antenna 7. The communication control

unit 6 is provided with a communication control circuit 31 that controls flow between the received signal and the transmitted signal as described above to pass the signals from/to the transmitted-received data processing circuit 23 in the control unit 4.

The display apparatus 5 is configured to include a signal converting circuit 32 that converts a signal output from the display selection circuit 24 of the control unit 4 into an easily-displayable signal, and a display device 33 comprised of a CRT, for example.

Next, the failure diagnosis station 3 will be explained with reference to Fig. 3. The failure diagnosis station 3 has a communication control unit 9 having the same structure as the communication control unit 6 of the on-board apparatus 2, and is provided with a receiving circuit 34 that receives a failure data signal transmitted from the on-board apparatus 2 via an antenna 8, a received data demodulation circuit 35 that converts the received signal into an easily-processable signal, a received data buffer 36 that stores the processed signal, a transmitted-data buffer 37 that stores a diagnosis data signal output from the failure diagnosis unit 10, to be described later, and a transmitted data modulation circuit 38 that modulates the signal into a signal appropriate for being transmitted, and a transmitting circuit 39 that transmits the signal. The communication control unit 9 is also provided with a communication control circuit 40 that controls flow between the received signal and the transmitted signal to pass the signals from/to the failure diagnosis unit 10.

The failure diagnosis unit 10 is provided with a failure inference circuit 41, which is a host computer, and a rule-database file 42 in which processing methods for the failure data signal from the on-board apparatus 2 are filed. In the failure inference circuit 41, a display device 44 for displaying failure data and an inference result or the like from the above on-board apparatus 2 and a keyboard 45 for inputting required data or inputting a message to the vehicle, for example, are connected via an interface 43, and an output circuit 46 that outputs the diagnosis data from the failure inference circuit 41 to the above communication control unit 9 is provided.

Next, operation of the embodiment will be explained with reference to the flow chart of Fig. 4, centered around the operation of the computer 16 in the control unit 4 of the above on-board apparatus 2.

Firstly, in Step S<sub>1</sub>, the input signals 11a to 14a from each of the sensors 11 to 14 and control signals 18a to 20a output to each of the solenoids 18 to 20 used for controlling the automatic transmission are input to the failure detection section 16b of the computer 16, and whether or not a failure exists is detected based on a program saved in the memory 17. If it is determined in Step S<sub>2</sub> that there is a failure, an identification code for failure content is appended in front of the failure data, and whether or not a warning lamp 22 needs to be turned on is determined based on the identification code in Step S<sub>3</sub>. If the warning lamp 22 needs to be turned on, a signal for turning the lamp on is output to the warning lamp 22 in Step S<sub>4</sub> to turn on the lamp 22. Next in Step S<sub>5</sub>, the above failure data is transmitted as a transmitted signal from the communication control unit 6 to the failure diagnosis station 3 outside the vehicle, such as a service shop. The failure data signal is received by the communication control unit 9 in the failure diagnosis station 3, and input to the failure inference circuit 41 in the failure diagnosis unit 10. The failure inference circuit 41 performs failure diagnosis according to a processing method indicated in the rule-database file 42 in Step S<sub>6</sub>. Then, whether or not this information needs to be displayed on the display apparatus 5 of the on-board apparatus 2 is determined based on the significance of the failure, while the diagnosis data is transmitted from the communication control unit 9 to the vehicle with an identification code appended thereto.

The diagnosis data signal is received by the control unit 4 of the on-board apparatus 2 via the communication control unit 6 in Step S<sub>7</sub>. After the diagnosis data is temporarily saved in the memory 17 together with related information data in Step S<sub>8</sub>, whether or not a diagnosis result of the failure needs to be displayed is determined based on the identification code appended in front of the diagnosis data in Step S<sub>9</sub>. If the result needs to be displayed, it is displayed on the display device 33 provided in the vehicle in Step S<sub>10</sub>.

It is noted that, even when it has been determined that the warning lamp 22 does not need to be

turned on in Step S<sub>3</sub>, Step S<sub>5</sub> and the steps afterwards will still be followed and the failure data will be transmitted to the failure diagnosis station 3 to determine whether or not it needs to be displayed, as described above.

According to this example, as described above, whether or not a failure in the control system exists is detected based on the input signals 11a to 14a from each of the sensors 11 to 14 and control signals 18a to 20a output to each of the solenoids 18 to 20, for example, which are used for controlling the automatic transmission, while the failure data is transmitted to the failure diagnosis station 3 to determine its significance when a failure occurs. Only a failure with high significance will be displayed on the display apparatus 5 on board the vehicle, and therefore it prevents from causing anxiety for the person on board or causing a loss of trust in the vehicle or displayed failures, which may occur in the case where all failures are displayed.

If the display device 33 displays nothing despite the warning lamp 22 having been turned on, it may cause anxiety for the person on board. Hence, in this example, a manual switch 47 is provided as shown in Fig. 1 so that the result of the diagnosis performed in the failure diagnosis station 3 can be displayed on the display apparatus 5 inside the vehicle by operating the manual switch 47.

It is noted that the above example is an application of the present idea to a control system of an automatic transmission; however, the present idea may be applied to other control systems on board a vehicle, such as an anti-skid braking system 48 and an electronic fuel injection system 49, for example. In such a case, employing a multiplex transmission system among these systems will allow the communication control unit 6 shown in Fig. 2 on board of the vehicle to be shared. [Effect of the Invention]

As described above, the failure diagnosis apparatus for a vehicle according to the present invention does not display all failures in the vehicle, but rather, determines significance of a failure in the failure diagnosis station outside the vehicle to display only the failures with high significance on the display device, and thus this type of failure is only displayed as minimally required. It prevents failures from unnecessarily being

displayed and thereby causing anxiety to the person on board or creating a sense of distrust, and also prevents the person on board from becoming too familiar with displayed failures leading him/her to disregard highly significant failures, and therefore, it improves the reliability of displayed failures.

4. [Brief Description of the Drawings]

The drawings illustrate the example of the present invention. Fig. 1 is an overall schematic configuration diagram of the failure diagnosis apparatus for a vehicle; Fig 2 is a block diagram illustrating a configuration of the on-board apparatus; Fig. 3 is a block diagram illustrating a configuration of the failure diagnosis station; and Fig. 4 is a flow chart showing the failure diagnosis operations.

1... failure diagnosis apparatus for vehicle, 3... failure diagnosis station, 6... transmitting unit (communication control unit), 16... failure detection unit (computer), 33... display device, 41... significance determination unit (failure inference circuit)

Applicant: Mazda Motor Corporation

Agent: Masaaki

Fig. 1

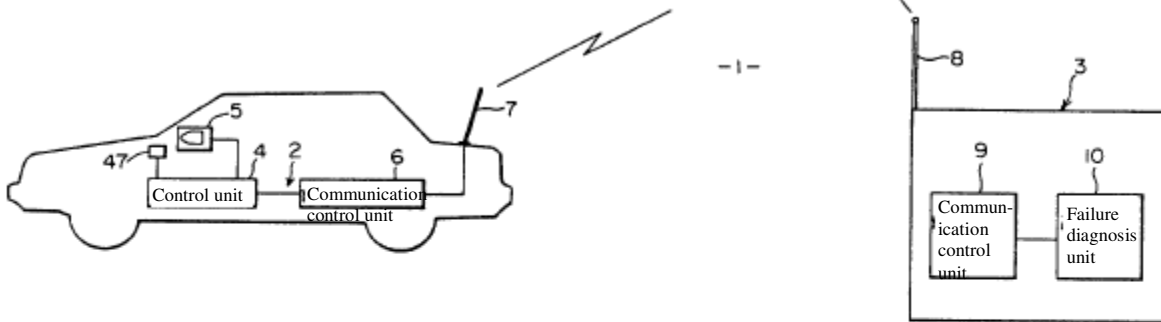
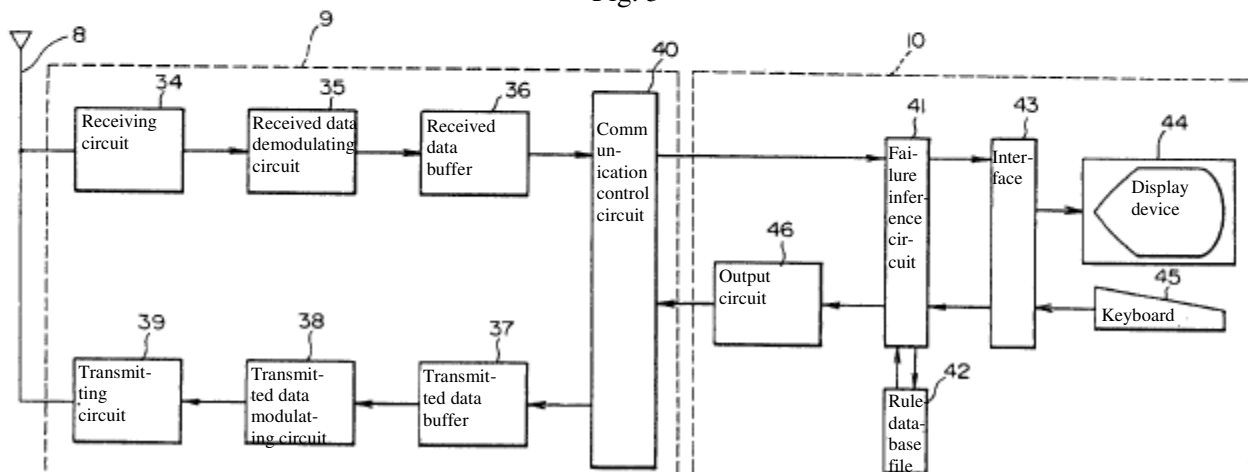

Fig. 3



# Explore Litigation Insights

Docket Alarm provides insights to develop a more informed litigation strategy and the peace of mind of knowing you're on top of things.

## Real-Time Litigation Alerts



Keep your litigation team up-to-date with **real-time alerts** and advanced team management tools built for the enterprise, all while greatly reducing PACER spend.

Our comprehensive service means we can handle Federal, State, and Administrative courts across the country.

## Advanced Docket Research



With over 230 million records, Docket Alarm's cloud-native docket research platform finds what other services can't. Coverage includes Federal, State, plus PTAB, TTAB, ITC and NLRB decisions, all in one place.

Identify arguments that have been successful in the past with full text, pinpoint searching. Link to case law cited within any court document via Fastcase.

## Analytics At Your Fingertips



Learn what happened the last time a particular judge, opposing counsel or company faced cases similar to yours.

Advanced out-of-the-box PTAB and TTAB analytics are always at your fingertips.

## API

Docket Alarm offers a powerful API (application programming interface) to developers that want to integrate case filings into their apps.

## LAW FIRMS

Build custom dashboards for your attorneys and clients with live data direct from the court.

Automate many repetitive legal tasks like conflict checks, document management, and marketing.

## FINANCIAL INSTITUTIONS

Litigation and bankruptcy checks for companies and debtors.

## E-DISCOVERY AND LEGAL VENDORS

Sync your system to PACER to automate legal marketing.