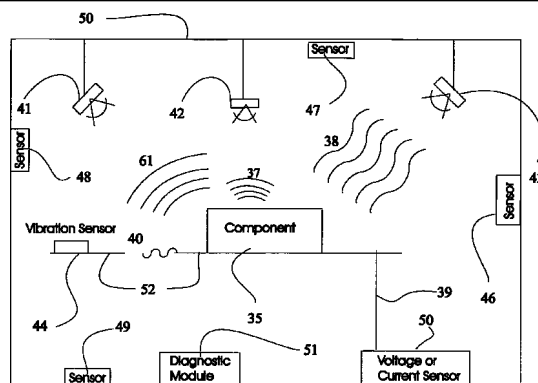

US7103460B1 20060905**(ENG) System and method for vehicle diagnostics****Assignee:** AUTOMOTIVE TECH INT US**Inventor(s):** BREED DAVID S US**Application No:** US 22013905 A**Filing Date:** 20050906**Issue/Publication Date:** 20060905

Abstract: (ENG) Method and system for diagnosing whether vehicular components are operating abnormally based on data obtained from sensors arranged on a vehicle. In a training stage, output from the sensors during normal operation of the components is obtained, each component is adjusted to induce abnormal operation thereof and output from the sensors is obtained during the induced abnormal operation. A determination is made as to which sensors provide data about abnormal operation of each component based on analysis of the output from the sensors during normal operation and during induced abnormal operation of the components. During operation of the vehicle, the output from the sensors is obtained and analyzed, e.g., by inputting it into a pattern recognition algorithm or neural network generated during the training stage, in order to output an indication of abnormal operation of any components being diagnosed.

Priority Data: US 22013905 20050906 A Y; US 12006505 20050502 A C N; US 8273905 20050317 A 2 Y; US 3912905 20050119 A 2 N; US 70136103 20031104 A 2 N; US 64202803 20030815 A 2 Y; US 63874303 20030811 A 2 N; US 61345303 20030703 A 2 N; US 33093802 20021227 A 2 N; US 18867302 20020703 A 1 N; US 75318601 20010102 A 2 Y; US 13791898 19980820 A 2 N; US 47607795 19950607 A 2 Y; US 17470902 20020619 A 2 N; US 7906502 20020219 A 2 N; US 4355702 20020111 A 2 N; US 92506201 20010808 A 2 N; US 76702001 20010123 A 2 N; US 35631499 19990716 A 2 N; US 94766197 19971009 A C Y; US 7340398 19980506 A 2 N; US 57124795 19951212 A 2 Y; US 55021795 19951030 A C Y; US 76555801 20010119 A 2 Y; US 64570900 20000824 A 2 Y; US 65875003 20030909 A 2 N; US 81960997 19970317 A 2 N; US 23997794 19940509 A C N; US 59283804 20040730 P Y; US 46164803 20030408 P Y; US 42361302 20021104 P Y; US 41586202 20021003 P Y; US 30401301 20010709 P Y; US 29151101 20010516 P Y; US 26941501 20010216 P Y; US 23137800 20000908 P Y; US 17097399 19991215 P Y; US 2804696 19961009 P Y;

Related Application(s): 60/592838 20040730 00 60/461648 20030408 00<RDA provisional application> 60/423613 20021104 00<RDA provisional application> 60/415862 20021003 00<RDA provisional application> 60/304013 20010709 00<RDA provisional application> 60/291511 20010516 00<RDA provisional application> 60/269415 20010216 00<RDA provisional application> 60/231378 20000908 00<RDA provisional application> 60/170973 19991215 00<RDA provisional application> 60/028046 19961009 00; 10/330938 10/188673 20020703 6738697 US A; 11/220139 11/120065 20050502 ABANDONED<RDA continuation-in-part> 11/120065 11/082739 20050317 PENDING 11/082739 11/039129 20050119 PENDING<RDA continuation-in-part> 11/039129 10/701361 20031104 6988026 US A 10/701361 10/642028 20030815 PENDING 10/642028 10/638743 20030811 PENDING<RDA continuation-in-part> 10/638743 10/613453 20030703 6850824 US A 10/613453 10/330938 20021227 6823244 US A 10/188673 09/753186 20010102 6484080 US A 09/753186 09/137918 19980820 6175787 US A 09/137918 08/476077 19950607 5809437 US A 10/701361 10/174709 20020619 6735506 US A 10/174709 10/079065 20020219 6662642 US A 10/079065 10/043557 20020111 6905135 US A 10/043557 09/925062 20010808 6733036 US A 09/925062 09/767020 20010123 6533316 US A 09/767020 09/356314

19990716 6326704 US A 09/356314 08/947661 19971009 ABANDONED 09/356314
 09/073403 19980506 6179326 US A <RDA continuation-in-part> 09/073403
 08/571247 19951212 5772238 US A 08/571247 08/550217 19951030 ABANDONED
 09/767020 09/765558 20010119 6748797 US A 09/765558 09/645709 20000824
 PENDING 11/082739 10/658750 20030909 6892572 US A 10/658750 08/819609
 19970317 6615656 US A 08/819609 08/239977 19940509 ABANDONED

IPC (International Class): G06F00700

US Class: 701029; 701033; 701034; 702183; 706015

Publication Language: ENG

Agent(s): Roffe Brian

Examiner Primary: Beaulieu, Yonel

Assignments Reported to USPTO:

Reel/Frame: 16962/0178 **Date Signed:** 20050902 **Date Recorded:** 20050906

Assignee: AUTOMOTIVE TECHNOLOGIES INTERNATIONAL, INC. P.O. BOX 8 DENVILLE NEW JERSEY 07834

Assignor: BREED, DAVID S.

Corres. Addr: BRIAN ROFFE ATI-379 11 SUNRISE PLAZA, SUITE 303 VALLEY STREAM, NY 11580

Brief: ASSIGNMENT OF ASSIGNORS INTEREST (SEE DOCUMENT FORDETAILS).

Legal Status:

Date	+/-	Code	Description
20050906	()	AS	ASSIGNMENT New owner name: AUTOMOTIVE TECHNOLOGIES INTERNATIONAL, INC., NEW J; : ASSIGNMENT OF ASSIGNORS INTEREST;ASSIGNOR:BREED, DAVID S.;REEL/FRAME:016962/0178; Effective date: 20050902;
20050906	()	AS	New owner name: AUTOMOTIVE TECHNOLOGIES INTERNATIONAL, INC., NEW J; : ASSIGNMENT OF ASSIGNORS INTEREST;ASSIGNOR:BREED, DAVID S.;REEL/FRAME:016962/0178; Effective date: 20050902;
20050906	()	AS	New owner name: AUTOMOTIVE TECHNOLOGIES INTERNATIONAL, INC., NEW J; : ASSIGNMENT OF ASSIGNORS INTEREST;ASSIGNOR:BREED, DAVID S.;REEL/FRAME:016962/0178; Effective date: 20050902;
20100905	()	REAS	Effective date: 20100905;

US6134492A 20001017

(ENG) Apparatus and method for adjusting pedals in a vehicle

Assignee: AUTOMOTIVE TECH INT US

Inventor(s): BREED DAVID S US ; DUVALL WILBUR E US ; MORIN JEFFREY L US

Application No: US 22602399 A

Filing Date: 19990106

Issue/Publication Date: 20001017

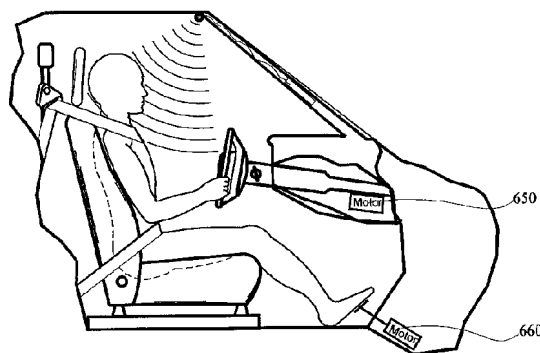

Abstract: (ENG) Method and apparatus for adjusting one or more pedals in a vehicle including a motor for moving the pedal(s). The motor is controlled either manually or automatically based on one or more measured morphological characteristics of the driver and/or the determined location of the driver. Another apparatus and method include a measuring arrangement for measuring the height of the driver from the driver seat in the vehicle, a motor coupled to the pedal(s), and a processor or control circuit coupled to the measuring arrangement for receiving the measured height of the driver, determining a suitable position of the pedal(s) based on the measured height of the driver, which is likely satisfactory for the particular driver, and controlling the motor to move the pedal(s) to the determined position thereof. The processor may include an algorithm including a table representing measured heights and a position of the pedal(s) corresponding to each measured height.

Priority Data: US 22602399 19990106 A N; US 12849098 19980804 A 1 Y; US 47478395 19950607 A 2 Y; US 97082297 19971114 A 2 Y;

Related Application(s): 09/128490 19980804 6078854 GRANTED; 08/474783 19950607 5822707 GRANTED 08/970822 19971114 PENDING

IPC (International Class): G01S01588; B60N00206; B60N00202; G01S01587; G01G019414; B60N00200; B60N00228; B60N00248; B60R02101; B60R02120; B60R021276; B60R02220; B60R02246; B60R021015; B60R02126; B60R02228; G01S01506; B60R021203

ECLA (European Class): B60R021015; B60N00200C; B60N00202B4; B60N00202B6; B60N00202B6B; B60N00202B6C; B60N00202B6W; B60N00206S; B60N00228; B60N00228B2; B60N00228P4; B60N00248C2C; B60N00248C3C; B60N00248W; G01G019414A; G01S01587; G01S01588

US Class: 701049; 074512; 180273; 280727; 701045

Examiner Primary: Chin, Gary

Legal Status:

Date	+/-	Code	Description
20040419	()	FPAY	Year of fee payment: 4;
20080618	()	REAN	Year of fee payment: 8;
20080619	()	SULP	Year of fee payment: 7;

US6950022B2 20050927
US2003002690A1 20030102

(ENG) Method and arrangement for obtaining and conveying information about occupancy of a vehicle

Assignee: AUTOMOTIVE TECH INT US

Inventor(s): BREED DAVID S US

Application No: US 22778002 A

Filing Date: 20020826

Issue/Publication Date: 20050927

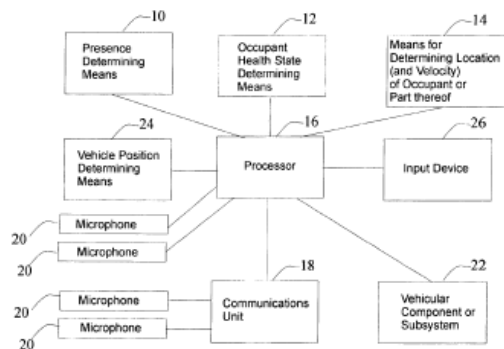

Abstract: (ENG) Method and arrangement for obtaining and conveying information about occupancy of a passenger compartment of a vehicle including at least one sensor for obtaining data from the passenger compartment. Information about the occupancy is generated based on the data and transmitted, e.g., through a cellular phone system, to emergency response personnel to enable them to respond accordingly. The information about the occupancy may be generated by a processor applying pattern recognition techniques so that any occupants of the seat may be classified and such classification transmitted to the emergency response personnel. The data may also be used to determine the number of occupants in the vehicle and/or whether the occupants are moving after a crash. The sensors may be a variety of sensors such as an ultrasonic sensor, an electromagnetic wave sensor, an electric field sensor, a chemical sensor, a weight sensor, a motion sensor, a microphone, a heartbeat sensor, a vibration sensor, an acceleration sensor and a capacitance sensor.

Priority Data: US 22778002 20020826 A N; US 83892001 20010420 A 1 Y; US 56355600 20000503 A 2 Y; US 43753599 19991110 A 2 Y; US 4770398 19980325 A 2 Y; US 64006896 19960430 A 2 Y; US 23997894 19940509 A B Y; US 4097893 19930331 A B Y; US 87857192 19920505 A C Y; US 90587697 19970804 A 2 Y; US 50503695 19950721 A 1 Y;

Related Application(s): 10/227780 09/838920 20010420 6778672 US A 08/640068 08/239978 19940509 ABANDONED<RDA continuation> 08/905876 08/505036 19950721 5653462 US A 08/505036 08/040978 19930331 ABANDONED; 09/838920 09/563556 20000503 6474683 US A 09/563556 09/437535 19991110 6712387 US A 09/437535 09/047703 19980325 6039139 US A 09/047703 08/640068 19960430 5829782 US A 08/239978 08/040978 19930331 ABANDONED<RDA continuation-in-part> 08/040978 07/878571 19920505 ABANDONED 09/047703 08/905876 19970804 5848802 US A 08/040978 07/878571 19920505 ABANDONED

IPC (International Class): B60N00248; B60N00228; B60N00202; G06K00900; B60R02101; B60R00112; B60R021015

ECLA (European Class): B60R021015; B60N00202B4; B60N00202B6B; B60N00202B6W; B60N00228P4; B60N00248W; G06K00900H

US Class: 340552; 34053916; 340561; 340565; 340667

Publication Language: ENG

Agent(s): Roffe Brian

Examiner Primary: Mullen, Thomas

US Post Issuance:

--US Certificate of Correction: 20060124 20060214 a Certificate of Correction was issued for this patent

--US Litigations: Automotive Technologies International Inc American Honda Motor Company Et A 20060317 Delaware 1:06cv187

Legal Status:

Date	+/-	Code	Description
20060124	()	CC	CERTIFICATE OF CORRECTION
20090327	()	FPAY	Year of fee payment: 4;
20090810	()	AS	New owner name: AUTOMOTIVE TECHNOLOGIES INTERNATIONAL, INC., NEW J; : ASSIGNMENT OF ASSIGNORS INTEREST;ASSIGNORS:BREED, DAVID S.;DUVALL, WILBUR E.;JOHNSON, WENDELL C.;REEL/FRAME:023075/0343;SIGNING DATES FROM 20010411 TO 20010417;

US6792342B2 20040914
US2003023362A1 20030130

(ENG) Apparatus and method for controlling a vehicular component

Assignee: AUTOMOTIVE TECH INT US

Inventor(s): BREED DAVID S US ; DUVALL WILBUR E US ; MORIN JEFFREY L US ; XU KUNHONG US

Application No: US 22778102 A

Filing Date: 20020826

Issue/Publication Date: 20040914

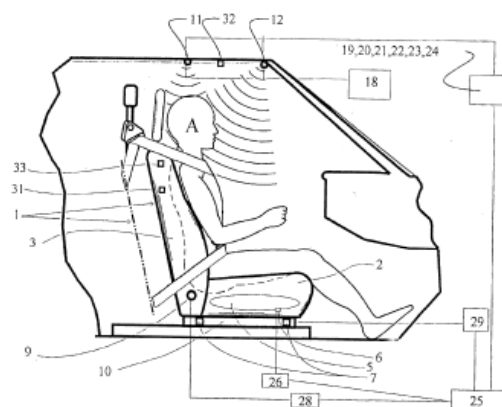

Abstract: (ENG) Arrangement and method for controlling a component in a vehicle in which at least one morphological characteristic of an occupant is measured and a current position of at least a part of a seat on which the occupant is situated is obtained. The component is controlled based on the measured morphological characteristic(s) and the current position of the seat. The component may be an occupant restraint device, such as an airbag whose inflation, deflation and/or deployment direction is/are controlled.

Priority Data: US 22778102 20020826 A N; US 6101602 20020130 A 2 Y; US 90187901 20010709 A 2 Y; US 84955901 20010504 A 1 Y; US 19320998 19981117 A 2 Y; US 12849098 19980804 A 2 Y; US 47478395 19950607 A 2 Y; US 97082297 19971114 A 2 Y; US 50034600 20000208 A 2 Y;

Related Application(s): 09/849559 20010504 PENDING; 10/061016 20020130 PENDING 09/901879 20010709 6555766 US A GRANTED (PATENT)<RDA continuation-in-part> 09/193209 19981117 6242701 US A GRANTED (PATENT) 09/128490 19980804 6078854 US A GRANTED (PATENT)<RDA continuation-in-part> 08/970822 19971114 6081757 US A GRANTED (PATENT) 08/474783 19950607 5822707 US A GRANTED (PATENT)<RDA continuation-in-part> 09/500346 20000208 6442504 US A GRANTED (PATENT) 09/128490 PENDING 08/970822 PENDING 08/474783 PENDING

IPC (International Class): B60N00268; G01G019414; B60N00202; B60N002015; G01S01588; B60N00200; B60N00266; B60N00206; B60R02101; B60N00228; G01S01587; B60N00248; G01S01506; B60R02246; B60R02220; B60R02120; B60R021203; B60R021276; B60R021015; B60R02126; B60R02228

Explore Litigation Insights

Docket Alarm provides insights to develop a more informed litigation strategy and the peace of mind of knowing you're on top of things.

Real-Time Litigation Alerts



Keep your litigation team up-to-date with **real-time alerts** and advanced team management tools built for the enterprise, all while greatly reducing PACER spend.

Our comprehensive service means we can handle Federal, State, and Administrative courts across the country.

Advanced Docket Research



With over 230 million records, Docket Alarm's cloud-native docket research platform finds what other services can't. Coverage includes Federal, State, plus PTAB, TTAB, ITC and NLRB decisions, all in one place.

Identify arguments that have been successful in the past with full text, pinpoint searching. Link to case law cited within any court document via Fastcase.

Analytics At Your Fingertips



Learn what happened the last time a particular judge, opposing counsel or company faced cases similar to yours.

Advanced out-of-the-box PTAB and TTAB analytics are always at your fingertips.

API

Docket Alarm offers a powerful API (application programming interface) to developers that want to integrate case filings into their apps.

LAW FIRMS

Build custom dashboards for your attorneys and clients with live data direct from the court.

Automate many repetitive legal tasks like conflict checks, document management, and marketing.

FINANCIAL INSTITUTIONS

Litigation and bankruptcy checks for companies and debtors.

E-DISCOVERY AND LEGAL VENDORS

Sync your system to PACER to automate legal marketing.