

(12) **United States Patent**
Breed

(10) **Patent No.:** **US 6,738,697 B2**
(45) **Date of Patent:** **May 18, 2004**

(54) **TELEMATICS SYSTEM FOR VEHICLE DIAGNOSTICS**

(75) Inventor: **David S. Breed**, Boonton Township, Morris County, NJ (US)

(73) Assignee: **Automotive Technologies International Inc.**, Denville, NJ (US)

(*) Notice: Subject to any disclaimer, the term of this patent is extended or adjusted under 35 U.S.C. 154(b) by 27 days.

(21) Appl. No.: **10/188,673**

(22) Filed: **Jul. 3, 2002**

(65) **Prior Publication Data**

US 2003/0009270 A1 Jan. 9, 2003

Related U.S. Application Data

(63) Continuation-in-part of application No. 09/753,186, filed on Jan. 2, 2001, now Pat. No. 6,484,080, which is a continuation-in-part of application No. 09/137,918, filed on Aug. 20, 1998, now Pat. No. 6,175,787, which is a continuation-in-part of application No. 08/476,077, filed on Jun. 7, 1995, now Pat. No. 5,809,437, application No. 10/188,673, application No. 10/079,065, filed on Feb. 19, 2002, which is a continuation-in-part of application No. 09/765,558, filed on Jan. 19, 2001, application No. 10/188,673, which is a continuation-in-part of application No. 10/174,709, filed on Jun. 19, 2002.

(60) Provisional application No. 60/304,013, filed on Jul. 9, 2001, provisional application No. 60/291,511, filed on May 16, 2001, provisional application No. 60/269,415, filed on Feb. 16, 2001, and provisional application No. 60/231,378, filed on Sep. 8, 2000.

(51) **Int. Cl.**⁷ **G01N 17/00; G06F 7/00**

(52) **U.S. Cl.** **701/29; 701/34**

(58) **Field of Search** **701/29, 33, 34, 701/36; 340/438, 439**

(56) **References Cited**

U.S. PATENT DOCUMENTS

4,128,005 A	12/1978	Arnston et al.	73/117.3
4,418,388 A	11/1983	Allgor et al.	364/431.01
4,817,418 A	4/1989	Asami et al.	73/118.1
4,989,146 A	1/1991	Imajo	701/29

(List continued on next page.)

FOREIGN PATENT DOCUMENTS

DE	3839959	11/1988
WO	00/29257	5/2000

OTHER PUBLICATIONS

Liubakka et al., "Failure Detection Algorithms Applied To Control System Design For Improved Diagnostics and Reliability", SAE Technical Paper Series, 02-29 To 04-04, 1988, pp. 1-7.

(List continued on next page.)

Primary Examiner—Yonel Beaulieu

(74) *Attorney, Agent, or Firm*—Brian Roffe

(57) **ABSTRACT**

Vehicle diagnostic system which diagnoses the state of the vehicle or the state of a component of the vehicle and generates an output indicative or representative thereof. A communications device transmits the output of the diagnostic system to a remote location, possibly via a satellite or the Internet. The diagnostic system can include sensors mounted on the vehicle, each providing a measurement related to a state of the sensor or a measurement related to a state of the mounting location, and a processor coupled to the sensors and arranged to receive data from the sensors and process the data to generate the output indicative or representative of the state of the vehicle or its component. The processor may embody a pattern recognition algorithm trained to generate the output from the data received from the sensors and be arranged to control parts of the vehicle based on the output.

62 Claims, 38 Drawing Sheets

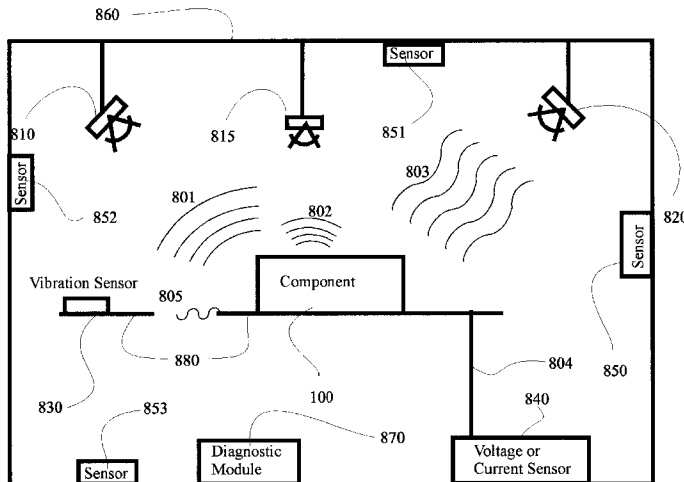

U.S. PATENT DOCUMENTS

5,041,976	A	8/1991	Marko et al.	364/424.03
5,056,023	A *	10/1991	Abe	701/32
5,123,017	A	6/1992	Simpkins et al.	714/26
5,164,901	A	11/1992	Blackburn et al.	701/47
5,313,407	A	5/1994	Tiernan et al.	364/508
5,325,082	A	6/1994	Rodriguez	340/438
5,333,240	A	7/1994	Matsumoto et al.	706/20
5,400,018	A	3/1995	Scholl et al.	340/825.54
5,406,502	A	4/1995	Haramaty et al.	364/551.01
5,420,794	A	5/1995	James	701/117
5,442,553	A	8/1995	Parrillo	364/424.04
5,481,906	A	1/1996	Nagayoshi et al.	73/116
5,581,464	A *	12/1996	Woll et al.	701/35
5,594,740	A	1/1997	LaDue	379/59
5,754,965	A	5/1998	Hagenbuch	701/35
5,809,437	A	9/1998	Breed	701/29
5,829,782	A	11/1998	Breed et al.	280/735
5,955,942	A	9/1999	Slifkin et al.	340/436
6,028,537	A	2/2000	Suman et al.	340/988
6,144,859	A	11/2000	LaDue	455/511
6,175,787	B1	1/2001	Breed	701/29
6,263,268	B1	7/2001	Nathanson	701/29
6,295,492	B1	9/2001	Lang et al.	701/33
6,339,736	B1	1/2002	Moskowitz et al.	701/29
6,356,822	B1	3/2002	Diaz et al.	701/33
2002/0103622	A1 *	8/2002	Burge	702/183

OTHER PUBLICATIONS

James et al., "Microprocessor Based Data Acquisition For Analysis Of Engine Performance", SAE Technical Paper Series, Feb. 23-27, 1987, pp. 1-9.

Engine Monitoring Based on Normalized Vibration Spectra, NASA Tech Briefs, MFS-26529, 1994.

V.K. Varadan et al., "Conformal MEMS-IDT Gyroscopes and Their Comparison with Fiber Optic Gyro, Smart Structures and Materials 2000", Smart Electronics and MEMS, Proceedings of SPIE vol. 3990 (2000), pp. 335-344.

H.K. Tonshoff et al., "Using Acoustic Emission Signals for Monitoring of Production Processes", Ultrasonics 37 (2000), pp. 681-686, 2000.

Design and Development of a MEMS-IDT Gyroscope, V.K. Varadan et al., Smart Mater. Struct. vol. 9, Jul. 21, 2000, pp. 898-905.

Microsensors, Microelectromechanical Systems (MEMS), and Electronics for Smart Structures and Systems, V.K. Varadan et al., Smart Mater. Struct., vol. 9, Feb., 1999, pp. 953-972.

Abstract of Wireless Remote Accelerometer, V.K. Varadan et al., in Physics of Semiconductor Devices, vol. 1: Proceedings of the 9th International Workshop on Physics of Semiconductor Devices (IWPSD), Delhi, India, Dec. 6-20, 1997.

Using Remote Diagnostics and Prognostics in the R&D Environment, Maggy Blagrove, no earlier than Jan., 2002.

Vetronix Corporation, WirelessRoad System Description, no earlier than Jan. 1, 2002.

Wingcast to Market Remote Vehicle Diagnostic and Prognostic Solutions with HP, Press Release dated May 15, 2002.

ATX Unveils Direct Telematics Link from Vehicle to Car Dealer, Press Release, Jan. 23, 2002.

Cosworth Technology, Inc. and North American Bus Industries (NABI) to Unveil the CompoBus™ Suited with the Revolutionary i3000 {R} Predictive Diagnostic System at APTA Conference in Ft. Worth, Texas, Oct. 28-31, 2001., Press Release, Oct. 28, 2001.

Telematics Integrated with Tire Pressure Monitoring, Press Release, Oct. 3, 2001.

* cited by examiner

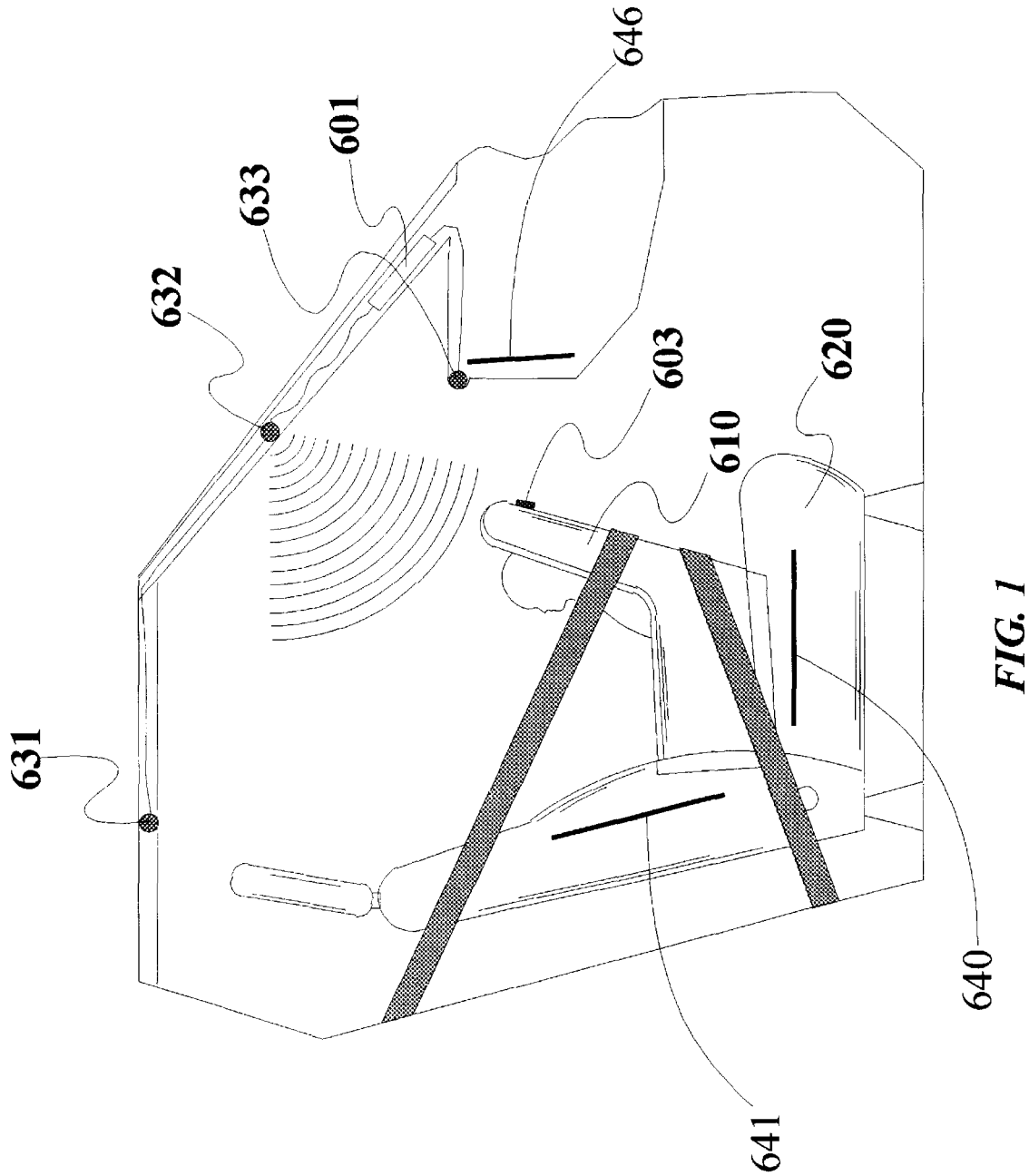

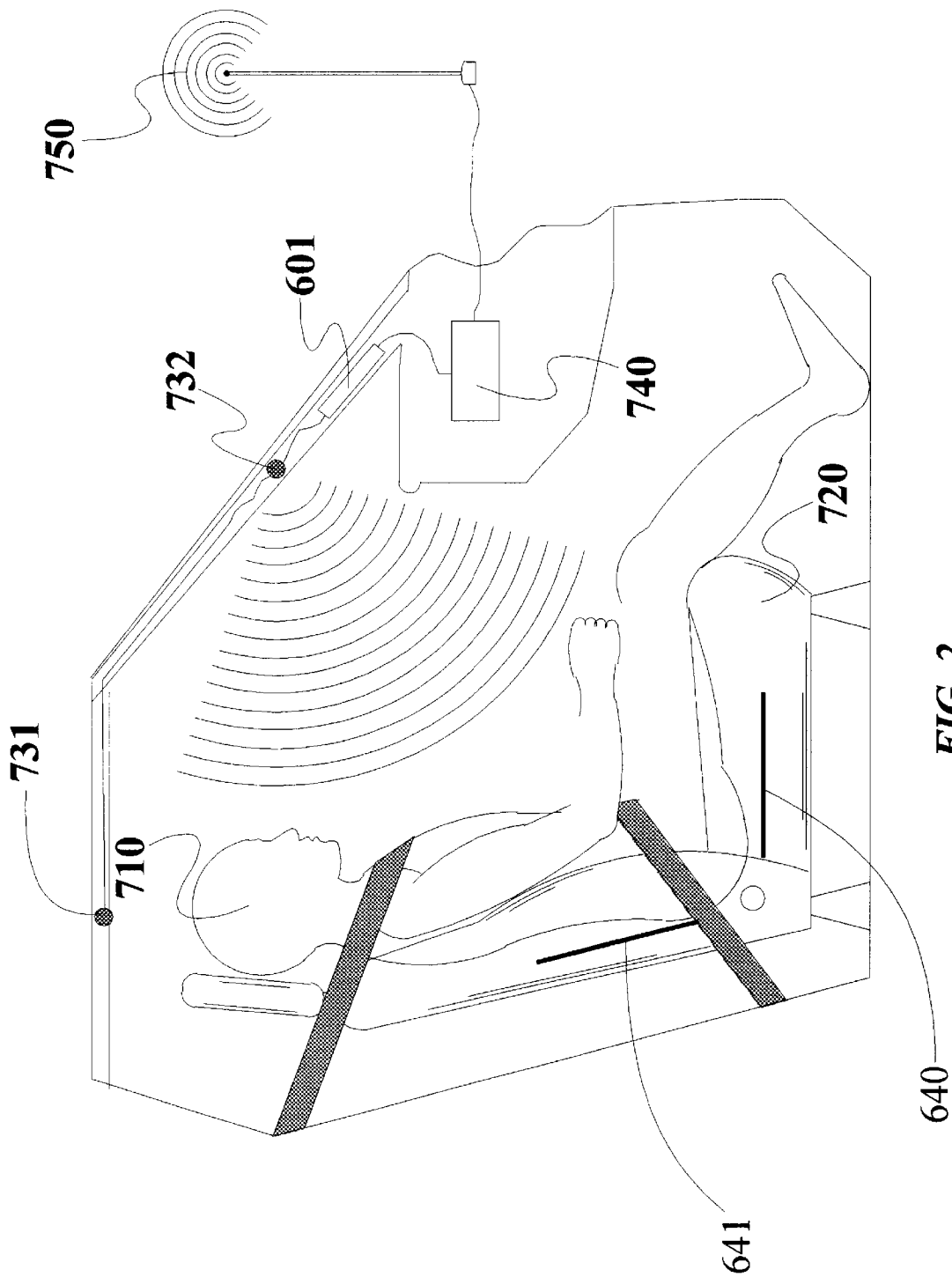

FIG. 2

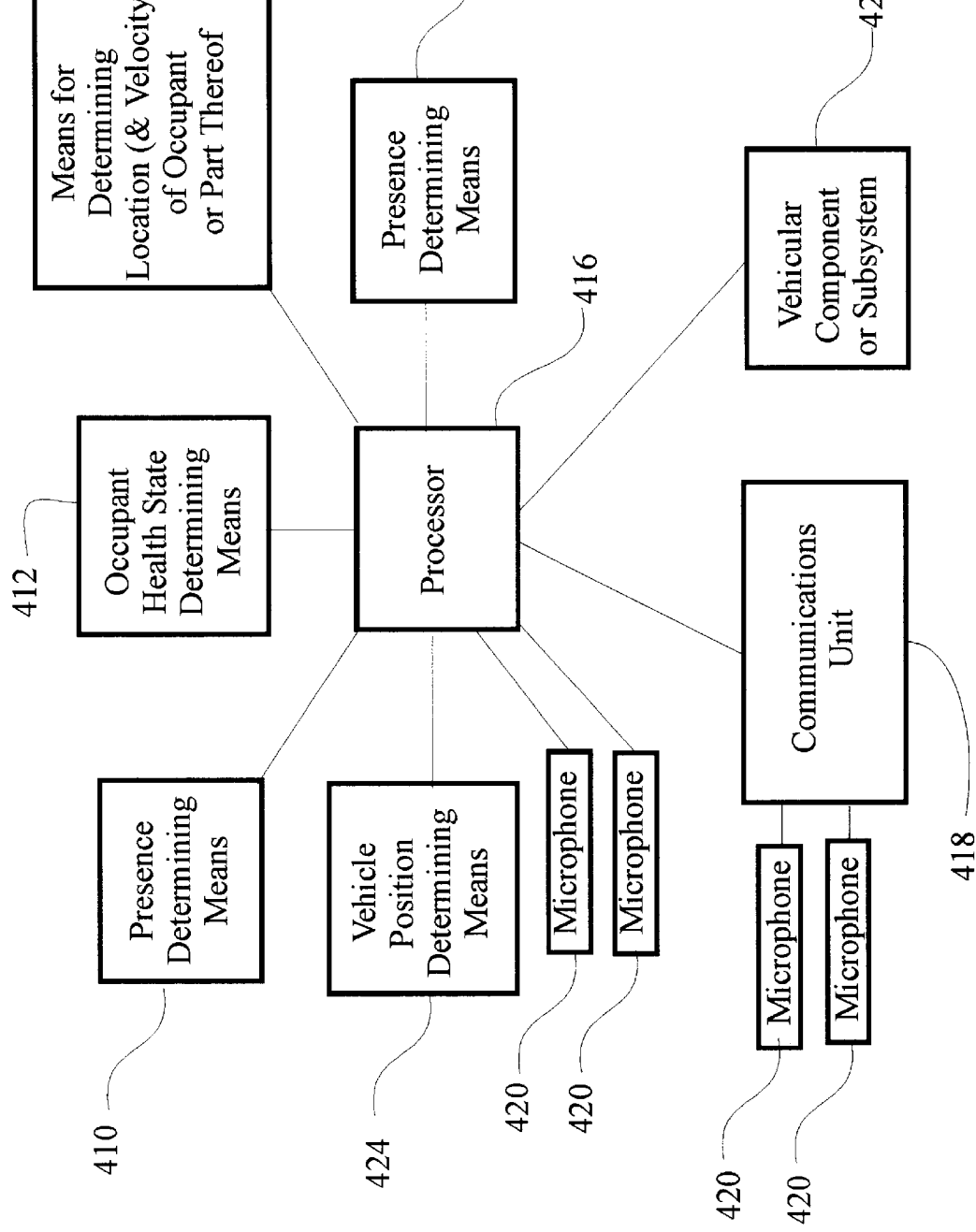

FIG. 3

Explore Litigation Insights

Docket Alarm provides insights to develop a more informed litigation strategy and the peace of mind of knowing you're on top of things.

Real-Time Litigation Alerts



Keep your litigation team up-to-date with **real-time alerts** and advanced team management tools built for the enterprise, all while greatly reducing PACER spend.

Our comprehensive service means we can handle Federal, State, and Administrative courts across the country.

Advanced Docket Research



With over 230 million records, Docket Alarm's cloud-native docket research platform finds what other services can't. Coverage includes Federal, State, plus PTAB, TTAB, ITC and NLRB decisions, all in one place.

Identify arguments that have been successful in the past with full text, pinpoint searching. Link to case law cited within any court document via Fastcase.

Analytics At Your Fingertips



Learn what happened the last time a particular judge, opposing counsel or company faced cases similar to yours.

Advanced out-of-the-box PTAB and TTAB analytics are always at your fingertips.

API

Docket Alarm offers a powerful API (application programming interface) to developers that want to integrate case filings into their apps.

LAW FIRMS

Build custom dashboards for your attorneys and clients with live data direct from the court.

Automate many repetitive legal tasks like conflict checks, document management, and marketing.

FINANCIAL INSTITUTIONS

Litigation and bankruptcy checks for companies and debtors.

E-DISCOVERY AND LEGAL VENDORS

Sync your system to PACER to automate legal marketing.