



US005157610A

United States Patent [19]

[11] Patent Number: **5,157,610**

Asano et al.

[45] Date of Patent: **Oct. 20, 1992**

- [54] **SYSTEM AND METHOD OF LOAD SHARING CONTROL FOR AUTOMOBILE**
- [75] Inventors: **Seiji Asano, Matsuta; Koza Katogi, Hitachi; Toshio Furuhashi, Mito; Shizuhisa Watanabe, Katsuta; Kiyoshi Miura, Ibaraki, all of Japan**
- [73] Assignee: **Hitachi, Ltd., Tokyo, Japan**
- [21] Appl. No.: **480,284**
- [22] Filed: **Feb. 15, 1990**
- [30] **Foreign Application Priority Data**
Feb. 15, 1989 [JP] Japan 1-33595
- [51] Int. Cl.⁵ **G06F 13/00**
- [52] U.S. Cl. **364/424.03; 364/424.01; 73/117.3**
- [58] Field of Search 364/431.01, 424.03, 364/551.01, 424.04, 138; 340/870.16, 870.03; 73/117.2, 117.3

OTHER PUBLICATIONS

IEEE Spectrum, vol. 23, No. 6, Jun. 1986, New York US pp. 53-59.

Primary Examiner—Thomas G. Black

[57] ABSTRACT

A system and method for load sharing processing operations between a vehicle mounted station (105) and a stationary base station (25) having a large capacity host computer is described. The vehicle mounted station has detectors for determining operating conditions of a vehicle and controllers (3, 4, 501) for varying the operating conditions. The controllers are connected to a transmitter-receiver (5) which is arranged to communicate over a path (10) with a transmitter-receiver (11) of the base station. The base station has a host computer (18) having a large memory capacity. At predetermined intervals, for example, distance of travel or at engine stop, the vehicle transmitter (5) transmits operating conditions to the base receiver (11) for data processing and the base transmitter (11) then transmits processed data back to the vehicle receiver (5), whereupon the controllers (3, 4, 501) modify the vehicle operating conditions. The vehicle operating conditions may be an indication of life expectancy of fuel injectors or sensors, updating data processing maps. The presence of abnormal operating conditions may be detected by the vehicle mounted station, evaluated by the base station and an emergency warning indication provided back to the vehicle mounted station, or if the abnormal condition is not of an emergency nature then counter measures are transmitted from the base station to the vehicle mounted station.

[56] References Cited

U.S. PATENT DOCUMENTS

4,258,421	3/1981	Juhasz et al.	364/424.03
4,757,463	7/1988	Ballou et al.	364/551
4,796,206	1/1989	Boscove et al.	364/551.01
4,853,859	8/1989	Morita et al.	364/424.04
4,939,652	7/1990	Steiner	364/424.04

FOREIGN PATENT DOCUMENTS

0002232	6/1979	European Pat. Off. .
0292811	11/1988	European Pat. Off. .
2535491	5/1984	France .
2559929	4/1985	France .
2100895	1/1983	United Kingdom .
2125578	3/1984	United Kingdom .
2179225	8/1985	United Kingdom .

20 Claims, 11 Drawing Sheets

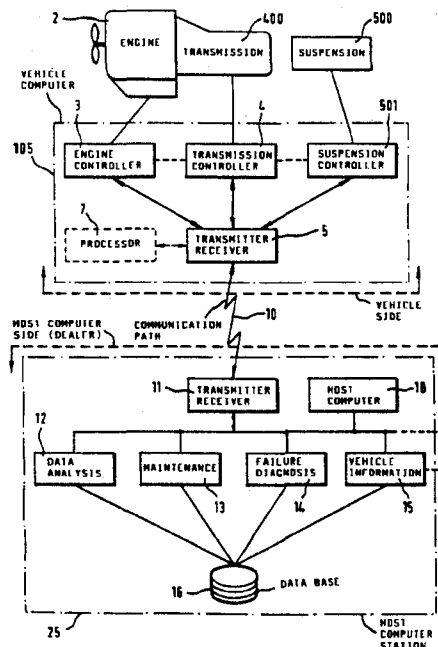

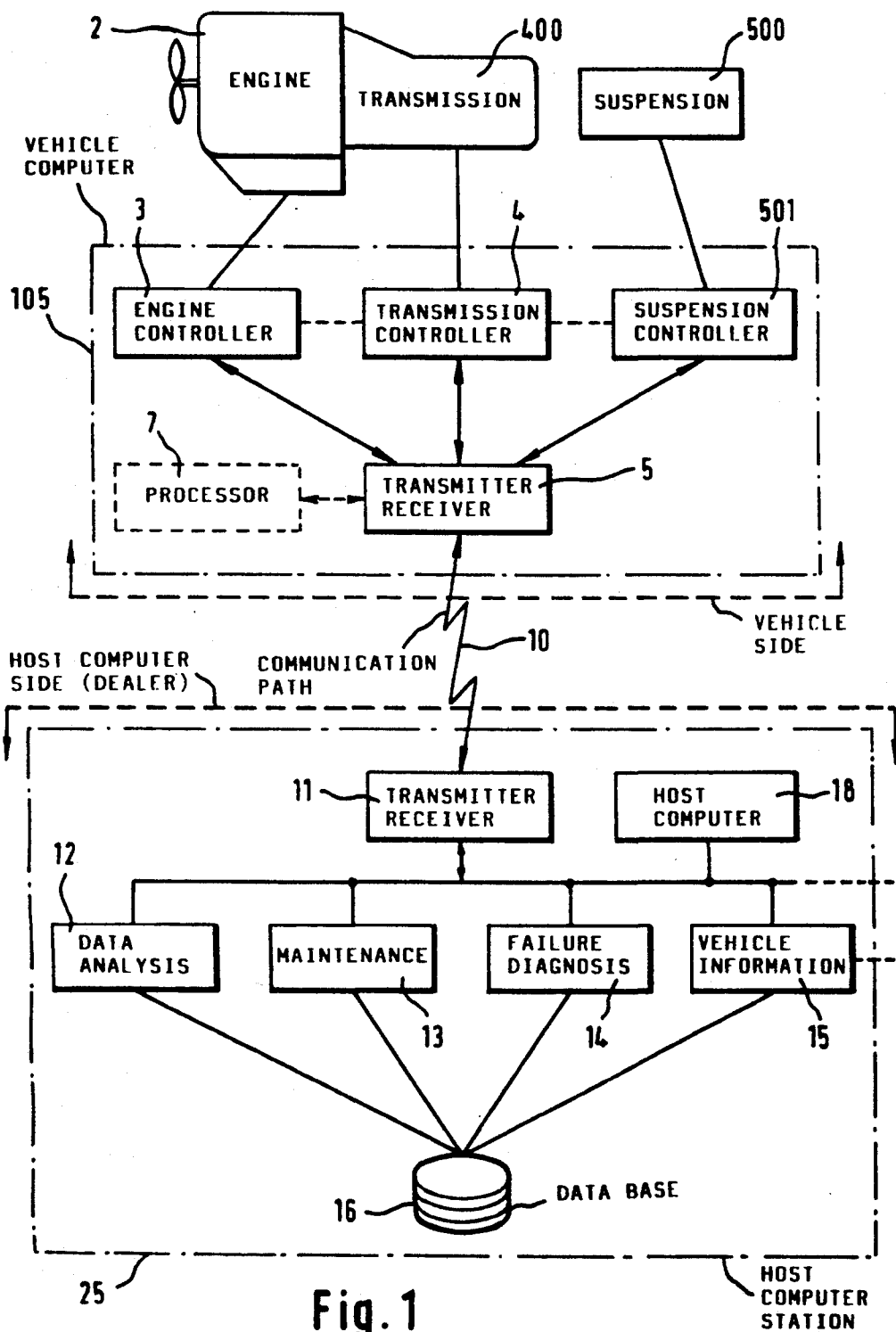

Fig. 1

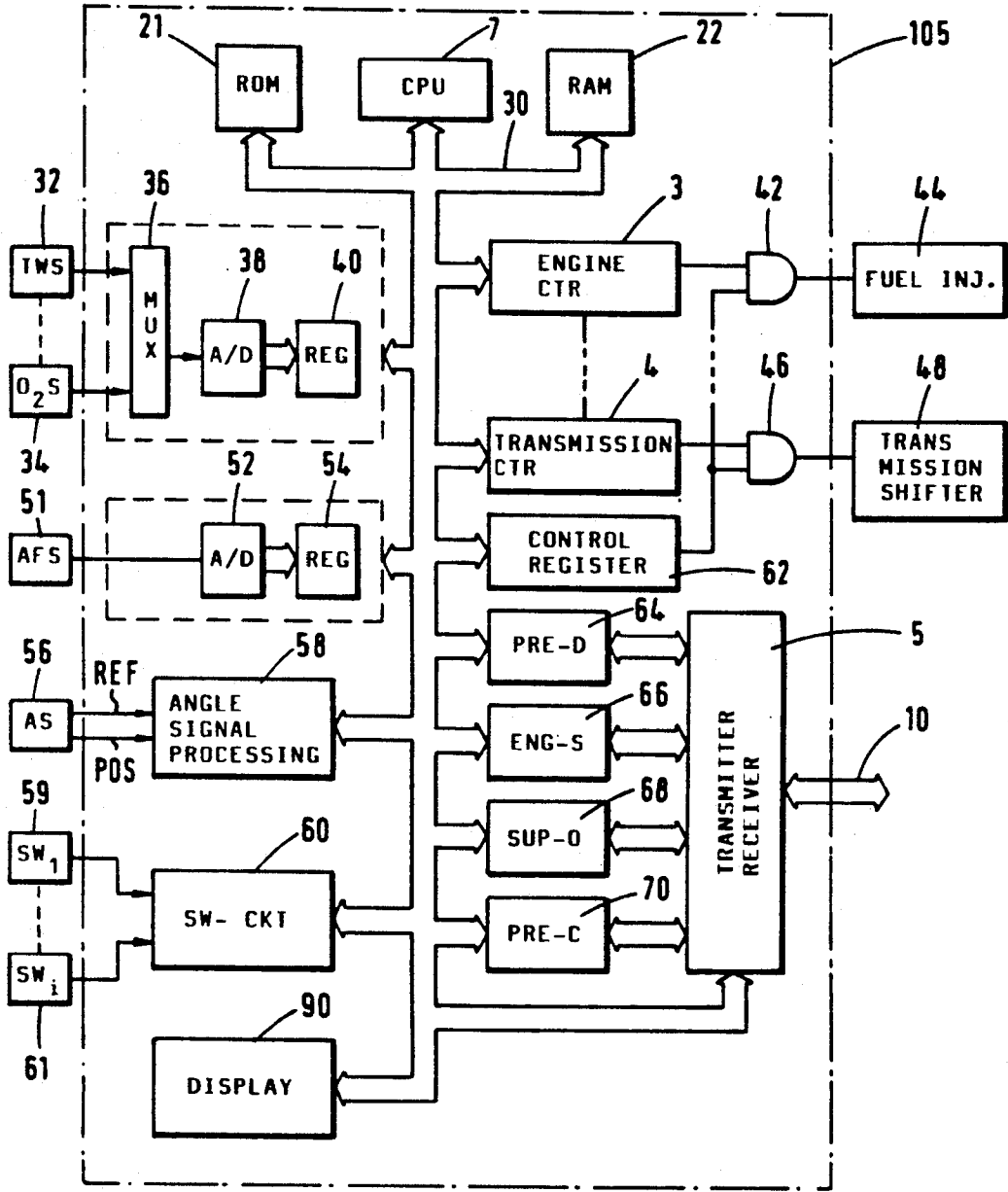

Fig. 2

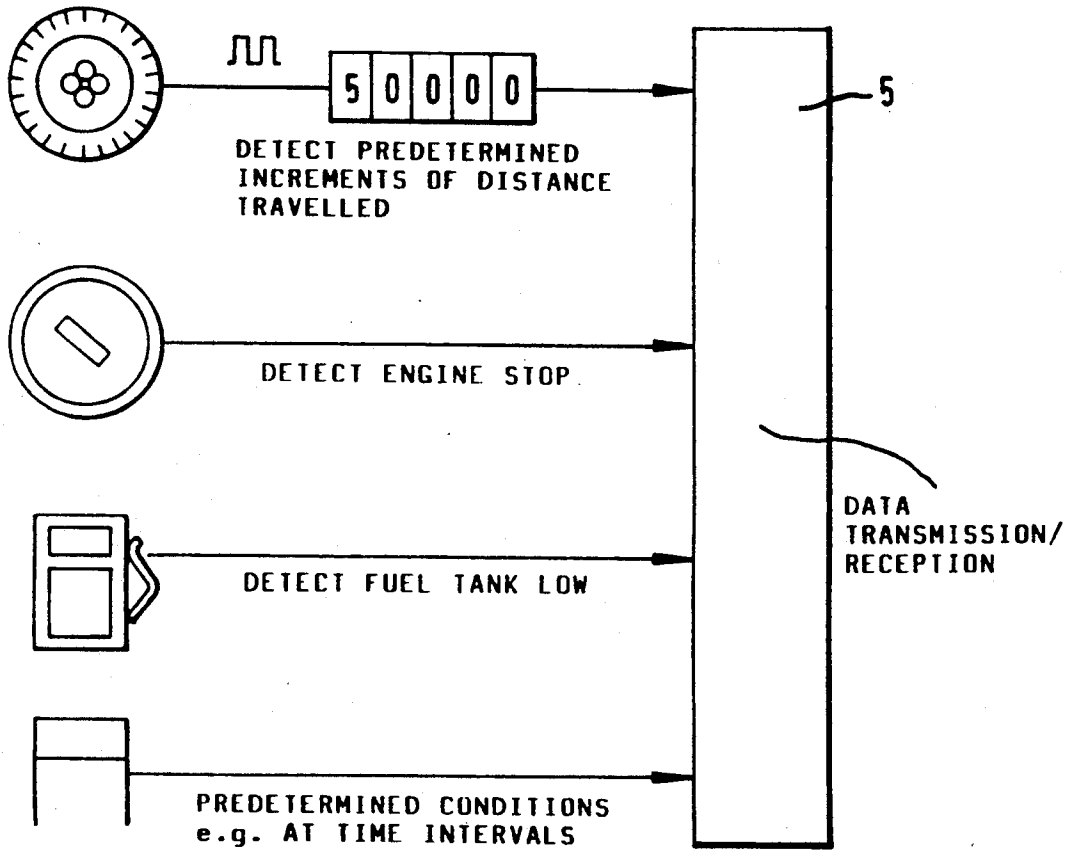

Fig. 3

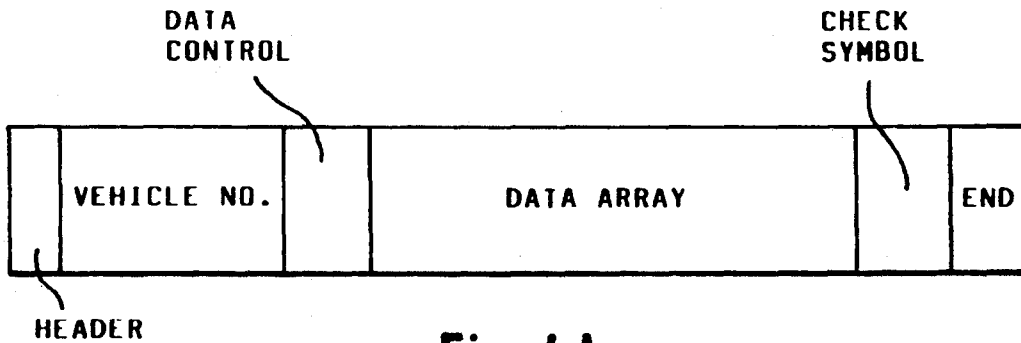

Fig.4A

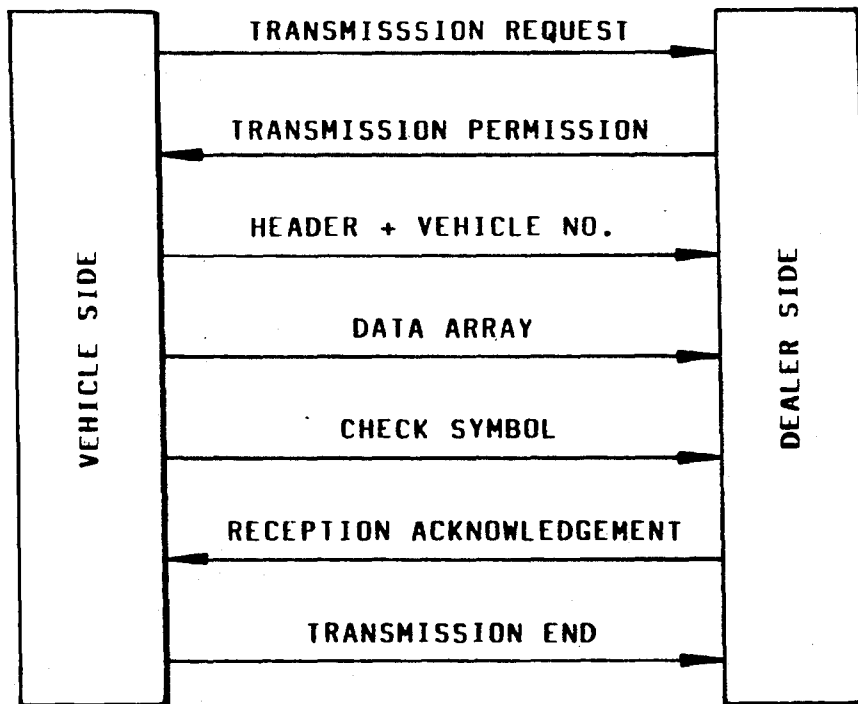

Fig.4B

Explore Litigation Insights

Docket Alarm provides insights to develop a more informed litigation strategy and the peace of mind of knowing you're on top of things.

Real-Time Litigation Alerts



Keep your litigation team up-to-date with **real-time alerts** and advanced team management tools built for the enterprise, all while greatly reducing PACER spend.

Our comprehensive service means we can handle Federal, State, and Administrative courts across the country.

Advanced Docket Research



With over 230 million records, Docket Alarm's cloud-native docket research platform finds what other services can't. Coverage includes Federal, State, plus PTAB, TTAB, ITC and NLRB decisions, all in one place.

Identify arguments that have been successful in the past with full text, pinpoint searching. Link to case law cited within any court document via Fastcase.

Analytics At Your Fingertips



Learn what happened the last time a particular judge, opposing counsel or company faced cases similar to yours.

Advanced out-of-the-box PTAB and TTAB analytics are always at your fingertips.

API

Docket Alarm offers a powerful API (application programming interface) to developers that want to integrate case filings into their apps.

LAW FIRMS

Build custom dashboards for your attorneys and clients with live data direct from the court.

Automate many repetitive legal tasks like conflict checks, document management, and marketing.

FINANCIAL INSTITUTIONS

Litigation and bankruptcy checks for companies and debtors.

E-DISCOVERY AND LEGAL VENDORS

Sync your system to PACER to automate legal marketing.