

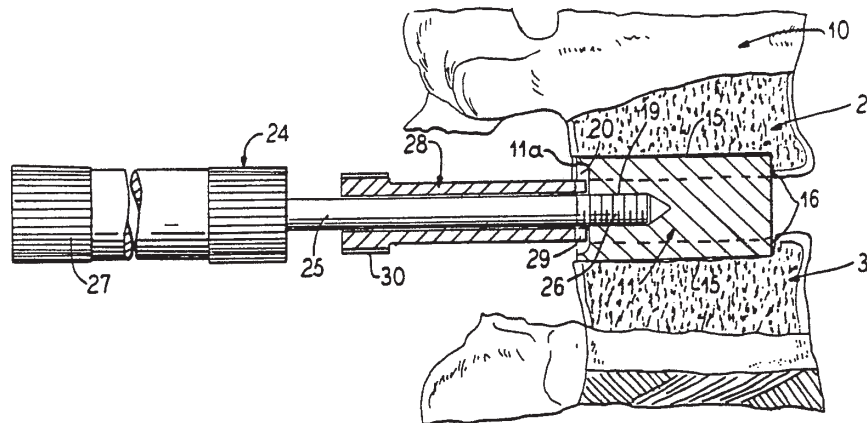

INTERNATIONAL APPLICATION PUBLISHED UNDER THE PATENT COOPERATION TREATY (PCT)

<p>(51) International Patent Classification 4 : A61F 2/44</p>	<p>A1</p>	<p>(11) International Publication Number: WO 89/ 09035 (43) International Publication Date: 5 October 1989 (05.10.89)</p>
<p>(21) International Application Number: PCT/US89/00905 (22) International Filing Date: 10 March 1989 (10.03.89) (31) Priority Application Number: 173,928 (32) Priority Date: 28 March 1988 (28.03.88) (33) Priority Country: US (71)(72) Applicant and Inventor: BRANTIGAN, John, W. [US/US]; 2108 Bramblewood Lane, Fremont, NB 68025 (US). (74) Agent: LEHMAN, Edward, A.; Hill, Van Santen, Steadman & Simpson, 70th Floor, Sears Tower, Chicago, IL 60606 (US). (81) Designated States: AU, BB, BG, BJ (OAPI patent), BR, CF (OAPI patent), CG (OAPI patent), CM (OAPI patent), DK, FI, GA (OAPI patent), HU, JP, KP, KR, LK, LU, MC, MG, ML (OAPI patent), MR (OAPI patent), MW, NL, NO, RO,</p>		<p>SD, SE, SN (OAPI patent), SU, TD (OAPI patent), TG (OAPI patent). Published <i>With international search report.</i></p>

(54) Title: SURGICAL PROSTHETIC IMPLANT FACILITATING VERTEBRAL INTERBODY FUSION



(57) Abstract

Prosthesis plug implants (11, 31-34, 111) forming side-by-side transverse struts between adjacent vertebrae have roughened surfaces (11b, 31b, 32b, 34d, 122) receiving bone ingrowth to fuse the plugs on prepared surface sites (15, 115) on opposed faces of adjacent vertebrae and have end faces (11a, 31a, 34a, 111c) with tool receiving recesses (19, 111d) securing the plug on a tool (24, 120) for insertion on the prepared sites of the vertebrae and for removing the tool from the plug without disturbing its position on the sites. These sites can be prepared by feeding a drill (21) through a guide (22) fixed to posterior or anterior sides of adjacent vertebrae to form the prepared sites including cortex bone (18, 118) in the opposed faces of the adjacent vertebrae and terminating the drilling in advance of the opposite sides of the vertebrae (16, 116). Gauge blocks (119) may be used to stretch collapsed disc tissue (112a) between the vertebrae to reclaim normal disc space between the vertebrae. A preferred implant (111) is rectangular, has nubs (122) on the sidewalls thereof, slots (124-125) receiving bone graft material (26) and is formed of radiolucent material.

FOR THE PURPOSES OF INFORMATION ONLY

Codes used to identify States party to the PCT on the front pages of pamphlets publishing international applications under the PCT.

AT Austria	FR France	ML Mali
AU Australia	GA Gabon	MR Mauritania
BB Barbados	GB United Kingdom	MW Malawi
BE Belgium	HU Hungary	NL Netherlands
BG Bulgaria	IT Italy	NO Norway
BJ Benin	JP Japan	RO Romania
BR Brazil	KP Democratic People's Republic of Korea	SD Sudan
CF Central African Republic	KR Republic of Korea	SE Sweden
CG Congo	LI Liechtenstein	SN Senegal
CH Switzerland	LK Sri Lanka	SU Soviet Union
CM Cameroon	LU Luxembourg	TD Chad
DE Germany, Federal Republic of	MC Monaco	TG Togo
DK Denmark	MG Madagascar	US United States of America
FI Finland		

- 1 -

"SURGICAL PROSTHETIC IMPLANT FACILITATING
VERTEBRAL INTERBODY FUSION"

This invention relates to the art of
prosthetic devices inserted transversely in a
5 vertebral column on prepared sites of the opposed
faces of adjacent vertebrae forming struts which are
fused into the vertebrae to maintain a normal disc
space between the vertebrae. These devices are in the
form of rigid inert plugs spanning the disc space in
10 side-by-side relation and having roughened surfaces
facilitating ingrowth of bone tissue.

The plugs are mounted endwise on a tool to
facilitate insertion between the adjacent vertebrae,
have a height that will reclaim the normal disc space
15 and will stretch remaining tissue of a collapsed
damaged disc. Preferred plugs have barbs biting into
the vertebrae, slots for carrying bone graft material,
tapered leading ends facilitating insertion between
the vertebrae and are formed from a radiolucent
20 material.

As pointed out in my United States Patent
4,743,256, issued May 10, 1988, the leading cause of
low backpain arises from rupture or degeneration of
lumbar intervertebral discs. Pain in the lower
25 extremities of the back (sciatica) is caused by
compression of spinal nerve roots by damaged discs
between the vertebrae and low back pain is caused by
collapse of the disc and the adverse effects of
bearing the majority of the body weight through a
30 damaged unstable vertebral joint. Surgical treatments
for relief of the sciatic pain and lower back pain
generally include the following:

- 2 -

1.) Excision Of The Ruptured Soft Disc

This procedure removes the portion of the disc compressing the spinal nerve and is generally successful in relieving the sciatic leg pain but in more than half of the cases, there is a recurrence of back pain. Over a period of time the disc gradually loses height due to the rupture and this loss of height causes the posterior facet joints of the vertebrae to fit incorrectly resulting in arthritic change in all elements of the spinal segment. Recurrent nerve root compression due to bony encroachment (spinal stenosis) also develops. The continuing and recurring back pain from this source has created a leading source of pain and disability.

2.) Disc Excision With Posterior Fusion

Traditional posterior fusion, creating bone growth between the bony laminae, or postero-lateral fusion between the transverse processes prevents motion between the adjacent vertebrae but does not alter the fact that approximately 90% of the body weight must be transmitted through degenerated discs causing pain. Further, posterior fusion tends to cause bony overgrowth leading to nerve root compression by spinal stenosis.

3.) Disc Excision With Anterior Interbody Fusion

Interbody fusion techniques, in which the soft disc is completely excised and replaced with either the patient's own bone (autologous bone) or with transplant banked bone (homologous bone) are generally successful if solid fusion can be obtained between adjacent vertebrae bodies. Unfortunately, the success rate has only been about 50%.

- 3 -

4.) Disc Excision With Posterior Lumbar
Intervertebral Fusion (PLIF)

This procedure reconstructs the normal
anatomic relationships between the bony and the neural
5 structures and has many advantages. Weight bearing
through a solid bony fusion mass between vertebral
bodies relieves the mechanical pain of the traditional
unstable degenerative disc and generally prevents long
term disc collapse or further degenerative changes.
10 The complete disc excision prevents recurrent
herniation of the same degenerated disc.

However, this PLIF procedure has several
serious disadvantages in that it is technically very
difficult, and, therefore, not as successful or widely
15 used as it might be. It entails large amounts of
blood loss in a small deep hole causing physiological
stress to the patient and psychological distress to
the surgeon. Further, the use of autologous bone
graft from the patient's own iliac crests extends the
20 operation and creates a second painful operative site.
Because it is difficult to obtain a large enough
quantity of autogenous bone with sufficient strength,
homologous bank bone is generally used.

Interbody bone grafting involves the
25 problems of strength and that of bone incorporation.
Strong cortex bone (the outer layer) is required as a
strut in the interbody position to prevent collapse of
the disc space while healing occurs. The surgeon has
the unfortunate requirement of having to fashion the
30 required struts with handheld tools during the
operation and these cortex bone struts are not wide
enough for optimum load bearing and they anchor
themselves by healing process that occurs very slowly

- 4 -

over a matter of years. Further, soft cancellous bone, which heals more reliably over a matter of 12 to 18 months, is also required for a traditional interbody fusion.

5 It is well understood in orthopaedic surgery, that grafted bone heals by a process called "creeping substitution" in which blood capillaries first grow into the grafted bone, the grafted bone is reabsorbed, and then new bone cells are laid down
10 along the bony matrix of the graft. During the time that the structural bone grafts struts are being reabsorbed, motion must still be prevented in the involved segments and although a brace or cast is often used, the entire process has proven less
15 reliable than desired. Homologous bank bone, being more "foreign", requires a much longer time to grow together and has a higher failure rate estimated at three times the failure as with the patient's own bone. In effect, neither source of bone is optimum
20 for the fusion procedure.

 My prior aforesaid U. S. Patent 4,743,256, discloses an improved surgical procedure for eliminating spinal back pain caused by ruptured or degenerated vertebral discs by spanning the disc space
25 between adjacent vertebrae with rigid implants having surfaces facilitating bone ingrowth and bottomed on prepared sites of the vertebrae to integrate the implant with the vertebrae and to provide a permanent weight supporting strut maintaining the disc space.

30 The present invention now further improves the art by providing the rigid implants with tool receiving end faces facilitating their insertion onto the prepared sites and having geometric patterns

- 5 -

of roughened surfaces on the peripheries of the implants enhancing bone ingrowth. This invention also still further improves the art by refining the implant method with novel tools.

5 According to the invention rigid plugs of the type generally disclosed in my aforesaid U.S. Patent 4,743,256 are further improved by providing end faces thereon with tool receiving recesses
10 facilitating insertion of the plugs into place on the prepared sites of adjacent vertebrae and having roughened peripheral surfaces with patterns
15 facilitating placement between the vertebrae, and enhancing bone ingrowth. The preferred plugs have one end thereof provided with an internally threaded axial
20 hole and wings or slots radiating from this hole in the end face. An insertion tool is threaded into the hole and is surrounded by a sleeve fitted into the slot recess. The plug, supported endwise on the tool is inserted in prepared sites of the adjacent
25 vertebrae and when properly positioned, the sleeve is held against rotation and the tool unthreaded from the plug without shifting the plug.

 The sites are preferably formed by a
25 drill surrounded by a drill guard with projecting teeth embedded in the posterior ends of adjacent
30 vertebrae to correctly position the drill for forming channels in the opposed faces of adjacent vertebrae. The channels are sufficiently wide and long to include hard cortex bone but preferably do not extend
 completely through the anterior side of the vertebrae. Conversely, if the drill is inserted from the anterior site of the vertebrae, the drilling operation is stopped short of the posterior side.

- 6 -

As disclosed in my aforesaid Patent 4,743,256, the plugs are made of an inert rigid metal, such as stainless steel, cobalt-chromium-molybdenum alloys, titanium or the like. According to this invention, however, the peripheral surface of these plugs need not have a porous coating of metal particles, such as disclosed in my prior application, but can be provided with roughened surfaces forming pits, prongs, bristles, nubs, or the like irregularities for anchoring bone ingrowth. These roughened surfaces can be part of the plug body or a coating on the body, such as a resin polymer. Bristle or prong surfaces can be rigid or flexible and, if desired, shaped to facilitate insertion and resist retraction.

A preferred threaded hole in the end face of the plug terminates less than one half the length of the plug and has a diameter of less than 1/3 the diameter of the plug. The wing or slot radiates diametrically from the hole in the end face of the plug, but terminates inwardly from the periphery of the plug.

A preferred polymer coating to form the roughened surface is nylon, a poly-olefin, a vinyl, or the like resin resistant to deterioration in the environment of the implant.

The present invention now also provides rectangular vertebral prosthesis implant plugs or blocks fitting rectangular transverse or perpendicular channels or grooves cut in the adjoining faces of vertebral bodies having heights that will stretch the remaining annulus tissue of the discs therebetween still connecting the vertebrae. Flat-sided

- 7 -

rectangular or square blocks or plugs are provided to fit these transverse rectangular channels or slots and have beveled or tapered leading ends easily inserted into the open ends of the transverse slots to spread
5 the vertebrae apart so that the top and bottom faces of each block or plug are tightly bottomed in the slot with the stretched disc tissues causing the vertebrae to grip the plugs. These plugs are inserted laterally or transversely of the vertebral column into the slots
10 while mounted on the end of an insertion tool, have roughened surfaces to facilitate the bone ingrowth and also have vertical or horizontal slots therethrough or intersecting vertical and horizontal slots, packed with bone graft material, such as strips of bone
15 excised from the iliac crest of the pelvis. This implant material provides a block of living bone that grows all around and through the implant plug into the bone of the vertebrae.

Also, according to this invention, the blocks or
20 plugs instead of being made of an inert metal, can be made of a radiolucent material, such as a plastic of the nylon, polycarbonate, polypropylene, polyacetal, polyethylene, and polysulfone type, preferably filled with glass or carbon fibers. These plastics can be
25 injection molded, are light in weight, have great load carrying strength and provide improved x-ray visualisation of bone healing. Fiber reinforced plastics composed of such materials filled with glass or carbon fibers are also desirable. Suitable carbon
30 fiber composites are supplied under the tradename "VICTREX P.E.S." which is polyether sulfone filled with carbon fibers. Suitable grades are "4101 G.L.-30" which is a 30 percent fiber glass filled and

- 8 -

"450 C.A.-30" which is a 30 percent carbon fiber filled. These materials are supplied from ICI Industries of Wilmington, Delaware. Carbon-carbon fiber plastics of the type sold by Fiber-Rite Corporation of Winona, Minnesota, are useful.

Preferred embodiments of the invention are illustrated in the annexed drawings in which:

FIG. 1 is a side elevational view of the lower portion of a human vertebral column with parts broken away and shown in section to illustrate prosthetic implants of this invention inserted between several of the lower vertebrae.

FIG. 2 is a posterior elevational view of a portion of FIGURE 1 taken along the line II-II of FIGURE 1.

FIG. 3 is a cross-sectional view with parts in elevation and broken away in section along the line III-III of FIGURE 2.

FIG. 4 is an enlarged fragmentary side elevational view with parts shown in vertical section illustrating the manner in which the implant receiving sites of adjacent vertebrae are prepared.

FIG. 5 is a view similar to FIGURE 4 illustrating the manner in which an implant is inserted in position on prepared sites of adjacent vertebrae.

FIG. 6 is a perspective view of one form of a prosthetic plug of this invention having a knurled periphery and showing the tool receiving recesses in an end thereof.

FIG. 7 is a perspective view of another form of implant plug of this invention having a pitted periphery.

- 9 -

FIG. 8 is a side elevational view with parts broken away and showing an axial section of a prosthetic plug of this invention with deflectable locking prongs on the periphery thereof.

5 FIG. 9 is a perspective view similar to FIGURE 6 illustrating a threaded periphery on the plug providing roughened surfaces.

10 FIG. 10 is a perspective view of a prosthetic plug of this invention with a resin coating thereof having radiating bristles.

FIG. 11 is a transverse sectional view along the line XI-XI of FIGURE 10.

15 FIG. 12 is a side-elevational view of the lower portion of a human vertebrae column with parts broken away and shown in section to illustrate flat-sided rectangular prosthetic implant plugs or blocks of this invention inserted in rectangular grooves or channels in the opposed faces of adjacent vertebrae to support the vertebrae in place of the human disc therebetween which has been partially excised to remove damaged and herniated tissue.

20 FIG. 13 is a posterior elevational view of a portion of FIGURE 12 taken along the line XIII-XIII of FIGURE 12.

25 FIG. 14 is a transverse sectional view, with parts in elevation and broken away in section, along the line XIV-XIV of FIGURE 13.

30 FIG. 15 is an enlarged fragmentary side elevational view, with parts broken away and shown in vertical section, illustrating the manner in which a trial or gauge plug or block of this invention is inserted in position in the transverse rectangular slots of adjoining vertebrae to stretch the remaining

- 10 -

interposed disc tissue connected to these vertebrae and to gauge the sites for receiving a proper sized permanent implant.

FIG. 16 is a plan view of a vertebrae disc with the interior pulp removed and with disc tissue partially excised to provide gaps or slots aligned with channels cut in the vertebrae to receive the plugs therethrough.

FIG. 17 is a perspective view of a smooth faced trial or gauge plug or block for use as shown in FIGURE 15.

FIG. 18 is a perspective view of a preferred form of permanent implant plug or block of this invention.

FIG. 19 is a longitudinal vertical sectional view of the plug of FIGURE 18 taken along the line XIX-XIX of FIGURE 18.

In FIGURES 1-5 the reference numeral 10 illustrates generally the lower portion of a human vertebral column with adjacent vertebrae supported on prosthetic implants of this invention or illustrating the manner in which sites are prepared for the implant and the manner in which an implant is inserted on the prepared sites.

In FIGURE 1, the vertebral column 10 shows the five lower vertebrae numbered 1-5. Adjacent vertebrae Nos. 2 and 3 and adjacent vertebrae Nos. 3 and 4 are separated by and supported on prosthetic implants 11 of this invention. Vertebrae Nos. 1 and 2 and vertebrae Nos. 4 and 5 are illustrated as supported on and separated by healthy or undamaged human discs 12 maintaining a disc space 13 between the adjoining vertebrae.

- 11 -

The natural human discs have been excised from between discs Nos. 2 and 3 and Nos. 3 and 4 with the disc spaces 14 being maintained by the implants 11. The opposed faces of adjoining vertebrae have prepared sites or channels 15 formed therein generally transversely of the axis of the column 10 to snugly receive cylindrical opposite faces of the implants 11. These transverse sites 15 are sufficiently wide and deep to span the central soft cancellous bone and include the hard cortex bone of the adjacent vertebrae. However, the sites have blind ends 16 to bottom the implants 11.

As shown in FIGURES 2 and 3, the implants 11 are in the form of a pair of side-by-side cylindrical plugs inserted endwise on the transverse sites 15 which are fragmental cylindrical to receive and mate with opposite faces of these plugs.

The soft cancellous bone of the vertebrae is illustrated at 17 in FIGURE 3 and is surrounded by the hard cortex bone 18 of the vertebrae No. 3. The prepared sites 15 include portions of this hard cortex so that the implants 11 span the softer cancellous bone 17 and rest on the hard cortex bone 18.

The plugs 11 fit snugly in the prepared sites 15 and are bottomed on the blind ends 16 of these sites.

The plugs are rigid, preferably solid, and have roughened surfaces forming extensive anchor points or pores for bone ingrowth from the adjoining vertebrae. They may be made of an inert metal, such as stainless steel, cobalt-chromium-molybdenum alloys, titanium, and the like. They may have many different shapes and peripheral surface configurations. They

- 12 -

have an end face with tool receiving recesses so as to be mounted on the tool for insertion on the prepared site and for removal of the tool without disturbing the mounting. These tool receiving recesses are
5 illustrated in the form of an internally threaded circular hole 19 tapped into one end face 11a of the plug. A radial slot 20 diametrically intersecting the tapped hole 19 is also provided in the end face 11a thus forming wings radiating from the tapped hole 19.
10 The hole 19 extends axially inward from the end face 11a for a relatively short distance sufficient to provide a number of thread turns to be firmly anchored on the threaded end of an insertion tool.

As shown in FIGURE 4, the sites 15 of the
15 adjoining vertebrae Nos. 2 and 3 are easily prepared by a rotary drill or burr 21 slidable through a drill guard 22 with teeth or prongs 23 penetrating and anchored in the posterior side of both vertebrae. The drill is advanced through the sleeve 22 through the
20 posterior sides of the vertebrae, but the drilling operation stops short of the anterior sides of these vertebrae so as to provide the blind ends 16 on the prepared sites.

While the sites 15 are easily prepared
25 with the drilling apparatus illustrated in FIGURE 4 it should be understood that sites of different shapes can be prepared with a mortise cutter or chisel shaped to conform with the shape of the implant to be inserted.

30 As shown in FIGURE 5 the implant 11 is easily inserted on the prepared sites 15 from the posterior side of the vertebrae Nos. 2 and 3 by means of a tool assembly 24 having a stem 25 with a threaded

- 13 -

end 26 mating with the tapped hole 19 in the end face
11a of the implant 11 and mounted in an easily grasped
handle 27 at the opposite end. A sleeve 28 is
slidably mounted on the stem 25 and has diametrically
5 opposite keys or lugs 25 on its forward end fitting
the radial slot 20. A knurled head 30 is provided on
the opposite end of the sleeve.

The tool 24 with the sleeve 28 retracted
on the stem 25 to expose the threaded end 26 of the
10 stem is threaded into the tapped hole 19 and bottomed
on the blind end thereof. The plug 11 is thus firmly
mounted on the tool and the tool is manipulated to
seat the plug on the prepared sites to be bottomed on
the blind ends 16 of the sites 15. After positioning
15 of the plug on the sites, the sleeve 28 is advanced on
the stem 25 to bottom the prongs 29 in the slot 20 and
the stem is unthreaded with the knurled head 30 of the
sleeve being firmly held to prevent rotation of the
sleeve and plug.

20 The plug 11 is illustrated in detail in
FIGURE 6 as having a solid cylindrical rod
configuration with its circular end face 11a having
the internally threaded hole 19 extending axially
inward therefrom and with the diametric intersecting
25 radial slot 20 providing the wings for receiving the
prongs 29 of the sleeve 28. The cylindrical rod 11
has a knurled roughened peripheral surface 11b forming
pyramid-like pits 11c for facilitating bone ingrowth.
The plug is dimensioned to snugly fit on the prepared
30 sites between the posterior and anterior side of the
vertebrae. Its dimensions may vary widely to suit
conditions and plug sizes of about 5/8" in diameter
and about 1" in length are useful. The tapped hole 19

- 14 -

in the end face 11a of such a plug need only be about 1/8" in diameter and 1/4" in depth. The slot should terminate short of the periphery and need only be about 1/8" deep.

5 Another suitable form of prosthetic implant of this invention is illustrated in FIGURE 7 where the device 31 has a square rectangular shape with an end face 31a having the tapped hole 19 and groove or slot 20. The device 31 has a pitted
10 periphery 31b forming a myriad of small pores to facilitate bone ingrowth.

 Another form of prosthetic device 32 is illustrated in FIGURE 8 in the form of a cylindrical
15 plug 32 with an end face 32a containing the tapped hole 19 and slot 20. The periphery of the cylindrical plug has longitudinally spaced circular ribs 32b. These ribs form dish-like prongs or barbs tilted toward the threaded end of the plug so that they will
20 deflect to slide into the prepared sites but will bite into the bone to resist retraction from the sites. As illustrated the ribs have convex leading faces 32c and concave trailing faces 32d. Such configuration assists deflection when the plug is pushed into
25 position but will spring back to resist reverse retraction or rotation. If desired the ribs can be axially slotted to provide a myriad of barbs.

 In the embodiment 33 of FIGURE 9 the implant is in the form of a solid cylindrical rod with an end face 33a containing the tapped hole 19 and slot
30 20 and with the cylindrical periphery being externally threaded as illustrated at 33b. The thread will advance the plug into the prepared sites when the plug

- 15 -

is rotated in a clockwise direction. The threads can have sharp edges to bite into the bone structure.

The implant plug 34 of FIGURES 10 and 11 has the same end face 34a as the other plugs with the tapped hole 19 and slot 20, however, it has a solid rigid circular rod core 34b with a polymeric resin cover 34c with the peripheral surface of the cover having upright projecting bristles 34d. These bristles form extended surfaces facilitating bone ingrowth.

Many other types of rough or irregular surfaces can be provided on the devices of this invention including porous metal coatings composed of metal balls and beads sintered on a rigid metal substrate as further disclosed in the aforesaid Patent No. 4,743,256.

The prosthetic implants are shown on the drawings as mounted in side-by-side parallel relation forming a pair of struts which maintain the disc space being snugly seated on hard cortex bone to carry the load. These implants have surfaces facilitating rapid bone ingrowth which will fuse the implants to the adjacent vertebrae in a relatively short growth period.

In FIGURES 12-14, the reference numeral 100 illustrates generally the lower portion of a human vertebral column with adjacent vertebrae supported on prosthetic implant blocks or plugs 111 of this invention.

FIG. 15 shows the manner in which adjacent vertebrae are spread apart to stretch collapsed intervening disc tissue as a gauge or trial

- 16 -

block of this invention is inserted laterally into transverse rectangular slots of adjoining vertebrae.

In FIGURE 12, the vertebral column 100 shows the five lower vertebrae Nos. 1-5. Adjacent
5 vertebrae Nos. 2 and 3 and adjacent vertebrae Nos. 3 and 4 are separated by and supported on the prosthetic implant blocks or plugs 111 of this invention. Vertebrae Nos. 1 and 2 and vertebrae Nos. 4 and 5 are
10 illustrated as supported on and separated by healthy or undamaged human discs 112 maintaining a normal disc space 113 between the adjoining vertebrae.

Damaged portions of the natural human discs 112 have been excised from the vertebrae Nos. 2 and 3 and Nos. 3 and 4 with the disc spaces 114 being
15 maintained by the implant blocks or plugs 111. It is preferred to retain as much as possible of the healthy annulus tissue of the discs 112 between the vertebrae so that the remaining disc tissue 112a will at least partially surround the implants and will be held under
20 tension by these implants. However, some of the remaining annulus disc tissue may have to be excised to open up spaces for the implant plugs 111.

The opposed faces of adjoining vertebrae have aligned flat-sided rectangular channels or
25 grooves 115 cut therein transversely of the axis of column 100 to first snugly receive test blocks or plugs of this invention for determining the proper sizes for the permanent implants 111. These transverse channels 115 are sufficiently wide and deep
30 to span the central soft cancellous bone and include the hard cortex bone of the adjacent vertebrae. The undamaged human disc tissue 112a remaining between the vertebrae is also cut or trimmed to receive the

- 17 -

implants 111 so that as much healthy annulus fibrous tissue as is available will surround the implants.

The preferred flat-sided rectangular channels 115 have blind ends 116 to be abutted by the
5 implants 111.

As shown in FIGURES 13 and 14, the implants 111 are in the form of a pair of side-by-side rectangular plugs inserted endwise into the transverse channels 115. These channels have flat bottoms and
10 sidewalls to snugly embrace the top and bottom ends and side faces of the rectangular plugs. The soft cancellous bone of the vertebrae is illustrated at 117 in FIGURE 14 and is surrounded by the hard cortex bone 118. The channels 115 include portions of this hard
15 cortex bone so that the implants 111 span the softer cancellous bone and rest on the hard cortex bone 118.

The channels 115 can be formed by a mortise cutting chisel tool and in the event disc tissue 112a blocks the paths for the plugs 111, tissue
20 can be trimmed or spread apart to open up the paths.

The implant plugs of blocks 111, as shown in FIGURES 18 and 19, are rigid, inert, solid, flat-sided rectangles, higher than wide and longer than high. They are used in cooperation with trial or
25 gauge blocks, such as 119, shown in FIGURE 17. These blocks 119 have flat, smooth sides and ends with flat top and bottoms 119a, flat sides 119b, a flat front end wall 119c, and a flat back end wall 119d. The front wall 119c is beveled to a reduced rectangular
30 nose surrounded by flat-sided tapered walls 119e with rounded corners 119f.

- 18 -

The back end wall 119d has an internally threaded blind axial hole 119g at the center of the wall.

5 The gauge blocks 119, in typical surgical operations, will have a length of about 25 mm, a width of about 11 mm and will vary in height from say, 13 to 17 mm, although it should be understood that these parameters may vary greatly and may depend on the size of the spinal column of the recipient. The tapers
10 119e are preferably about 30 degrees. The rounded corners 119f of the bevels eliminate sharp corners between the top, bottom and sides of the beveled faces.

As shown in FIGURE 15, a trial or gauge
15 block 119 is selected for force-fitting into the channels 115 while mounted on a tool 120 threaded into the hole 119g. The beveled front end 119c of the block will pass through any portion of the disc tissue 112a covering the entrance mouths of the channels 115
20 by either cutting holes through the remaining tissue or by spreading apart the fibers of the disc to accept the gauge blocks 119.

As shown in FIGURE 16, the remaining
25 healthy disc tissue 112a of a disc 112 between the channel cut vertebrae is trimmed to open up slots 121 permitting access of the gauge blocks 119 to the channels 115. These slots register with the channels 115 and can have open front ends 121a and blind back ends 121b. It is preferred to remove the nucleus
30 pulposus from the damaged disc 112 leaving an annulus of fibrous tissue connecting the adjoining vertebrae and surrounding the inserted blocks.

- 19 -

A proper fitting gauge block 119 is selected by trial and error insertions into the channel cut vertebrae. These blocks are smooth faced and can be removed even when tightly fitted in the
5 channels 115.

As shown in FIGURE 15, a gauge block 119, threaded on the end of an insertion tool 120 is selected to have a height greater than the height between the bottoms of opposed channels 115. Then,
10 when this block is pushed through the open ends of the aligned channels 115, the beveled nose 119c will engage the bottoms of these channels forcing them apart as the block is pushed into the channels thereby stretching any disc tissue 112a still connecting the
15 vertebrae. The block is pushed against the blind ends 116 of the channels and the tension on the disc fibers is determined. When a block 119 of sufficient size to properly load the disc tissue and to fit snugly in the channel, is located, a permanent implant plug 111 of a
20 size just slightly greater than the gauge block is selected. Such a permanent plug is then threaded on the end of a tool 120, the gauge block 119 is withdrawn, and the permanent implant 111 on the tool is forced into a position in the channels 115.

25 A preferred permanent implant block or plug 111 is illustrated in FIGURES 18 and 19. This plug has about the same flat side dimensions as the selected gauge block, but has projected from these flat top, bottom and sidewalls, a pattern of raised
30 annular nubs 122 providing a roughened surface, biting into and gripping the bottoms and sidewalls of the rectangular channels 115. These nubs are separated by annular grooves 123 and longitudinal channels 123a so

- 20 -

that each nub 122 will have a flat vertical back wall 122a, a pair of flat vertical sidewalls 122b and an inclined front face 122c.

The plug 111 has the same reduced nose 111a surrounded by the same beveled sidewalls 111b as the nose 119c and beveled sidewall 119e of the gauge block 119. In addition a vertical back wall 111c is the same as the back wall 119d and contains the same internally threaded hole 111d as the back wall 119d of the gauge block 119.

Further, the implant plug 111 has a vertical slot 124 therethrough connecting the tops and bottoms of the plug. This vertical slot 124 is rectangular, has a width about 1/3 the width of the block and a length extending close to the front and rear ends of the plug.

This slot 124 is intersected centrally by a horizontal through slot 125. It will be understood that, alternately, the block 111 may have only a single horizontal or vertical slot.

The slots 124 and 125 provide cavities in the block or plug 11 which are filled with strips of bone implant 126 preferably harvested from the pelvis bone of the recipient. This bone material housed in the implant plugs 111 will soon grow out of the grooves or channels 124 and 125 into the radial and longitudinal channels between the nubs 122 surrounding the plugs 111 and will then grow into the bone tissue of the adjoining vertebrae.

When the implant plug is pushed into its seated position between the vertebrae, the inclined front faces of the nubs 122 will accommodate the forward moving of the plug to the blind ends 116 of

- 21 -

the channels 115, but the sharp apexes of the nubs will prevent retraction of the plugs since they will bite into the vertebrae bone. Therefore, once the plugs are seated in proper position, they will not
5 shift from this position.

It is preferred that the height of the plugs 111 will be sufficient to maintain a tension load of about 20 to 30 pounds on the disc tissue. Such a tension load not only pulls the vertebrae
10 tightly against the plugs, but also accelerates bone ingrowth.

The preferred prosthesis plugs or blocks 111 of this invention not only facilitate and simplify the surgical procedure but also accelerate interbody
15 fusion of the vertebrae with the plug. The roughened surfaces provided by the nubs thus serve a multiple purpose of anchoring into the vertebrae, and providing channels for bone ingrowth.

20

- 22 -

CLAIMS:

1.) A prosthesis for a vertebral column (10, 100) transverse prepared sites (15, 115) opposed faces of adjoining vertebrae (2-3, 3-4) and a disc space (14, 114) between the adjoining vertebrae which comprises side-by-side rigid plugs (11, 31-34, 111) sized and shaped to form transverse struts bottomed on the prepared sites of the adjoining vertebrae and maintaining a desired disc space between said adjoining vertebrae, each plug having a roughened surface (11b, 31b, 32b, 34d, 122) interlocking with said prepared sites to facilitate bone ingrowth from the vertebrae, and each plug having an end face with tool receiving means extending internally of the plug (19, 111d) for fixedly mounting the plug endwise on a tool (24, 120) to facilitate endwise insertion of the plug on the prepared sites.

2.) A method of fusing together adjoining vertebrae bodies (2-3, 3-4) having spaced opposed faces with a disc space (14, 114) therebetween while maintaining said disc space which comprises mounting an inert rigid plug (11, 31-34, 111) with roughened surfaces (11b, 31b, 32b, 34d, 122) on the end of a tool (24, 120), cutting opposed transverse channels (15, 115) in said spaced opposed faces inwardly from adjoining sides of the vertebrae and terminating short of the opposite sides of the vertebrae (16, 116), inserting the plug endwise on the tool into said channels to form a strut supporting the vertebrae, removing the tool from the plug without moving the plug, and facilitating bone ingrowth from the vertebrae around said roughened surfaces in bonded relation thereto.

- 23 -

3.) A prosthetic device adapted for fusing together adjoining vertebrae (2-3, 3-4) with spaced opposed faces on opposite sides of a damaged collapsed vertebrae disc having tissue (112a) connecting the adjoining vertebrae bodies, said opposed faces of the vertebrae bodies having aligned transverse channels (15, 115) cut therein, and said disc tissue having openings (121a) therethrough aligned with the channels, which comprises a rigid inert plug (11, 31-34, 111) having a greater height than the damaged disc space between the bottoms of the aligned channels for force fit into the channels to stretch the disc tissue to maintain the original undamaged disc space, and surfaces (11b, 31b, 32b, 34d, 122) on said plug for engaging surfaces of the channels (15, 115) to facilitate ingrowth of bone tissue from the vertebrae bodies bottomed in the channels to fuse the bodies together in fixed relation.

4.) The method of using the device of claim 1 to fuse together spaced adjoining vertebrae bodies connected by collapsed damaged intervening disc tissues which comprises cutting aligned transverse channels (15, 115) into the adjoining faces of the spaced vertebrae, providing an opening (121a) into the disc tissue (112a) communicating with the aligned channels, forcing a rigid inert plug (11, 31-34, 111) into the channels and opening in the disc tissue to spread the adjoining vertebrae apart and stretch the disc tissue to maintain the disc space of the undamaged disc, and providing irregular surfaces (11b, 31b, 32b, 34d, 122) on said plug to grip the surfaces of the channels and facilitate bone ingrowth to fuse the plug to the vertebrae.

- 24 -

5 5.) The implant of claim 1 wherein the plug roughened surfaces are barbs (32b, 122) radiating from the rigid metal and having leading faces (32c, 122c) sloping toward the tool receiving end of the plug to bite into the vertebrae and provide extended areas receiving bone ingrowth.

10 6.) The implant of claim 1 wherein the tool receiving means is an internally threaded hole (19, 111d) in the end face of the plug for threaded engagement with the end of the tool.

7.) The implant of claim 6 including a radial slot (20) in the end face radiating from the internally threaded hole.

15 8.) The implant of claim 1 wherein the roughened surfaces are selected from the group consisting of knurled surfaces (11b), pitted surfaces (31b), barbed surfaces (32b, 122), bristle surfaces (34d), and threaded surfaces (32b) engaging the prepared sites.

20 9.) The implant of claim 1 wherein the roughened surfaces are barbs (32c, 32d) radiating from the plug periphery and deformable in the direction of insertion of the plug to facilitate insertion on the prepared sites and biting into the prepared sites upon attempted retraction of the plug.

25 10.) The implant of claim 1 wherein the plug is a solid rod (11, 31-34, 111) having a length sufficient to engage the hard cortex bone (18, 118) of the vertebrae and span the soft cancellous bone (17, 117) of the vertebrae without projecting beyond the cortex bone.

- 25 -

11.) The implant of claim 1 wherein the roughened surfaces (34d) are on the periphery of a plastics material coating (34c) on the plug.

5 12.) The device of claim 3 wherein the transverse channels (15, 115) are flat-sided and the rigid plug (31, 111) is rectangular.

13.) The device of claim 12 wherein the rectangular plug has a tapered leading end (119c) entering the channels.

10 14.) The device of claim 1 wherein the plug has a length greater than height and a width less than the height.

15 15.) The device of claim 1 wherein the plug has at least one slot (124, 125) therethrough adapted to receive bone graft material (126).

16.) The device of claim 15 wherein the plug has a longitudinal vertical slot (124) and a transverse horizontal slot (125) intersecting said vertical slot (124).

20 17.) The device of claim 3 wherein the plug has a myriad of radially extending nubs (122) the surface thereof separated by grooves (123).

18.) The device of claim 17 wherein the nubs (122) have inclined front faces (122c).

25 19.) The device of claim 3 wherein the plug (111) is formed from a radiolucent material.

20.) The plug (111) of claim 19 wherein the radiolucent material is filled with glass or carbon fibers.

30 21.) The device of claim 3 wherein the plug (111) is composed of a polyether sulfone resin filled with glass and carbon fibers.

- 26 -

22.) The device of claim 3 wherein the plug (111) has a bevelled front face (111a) and a rear face (111c) with a tool receiving recess (111d).

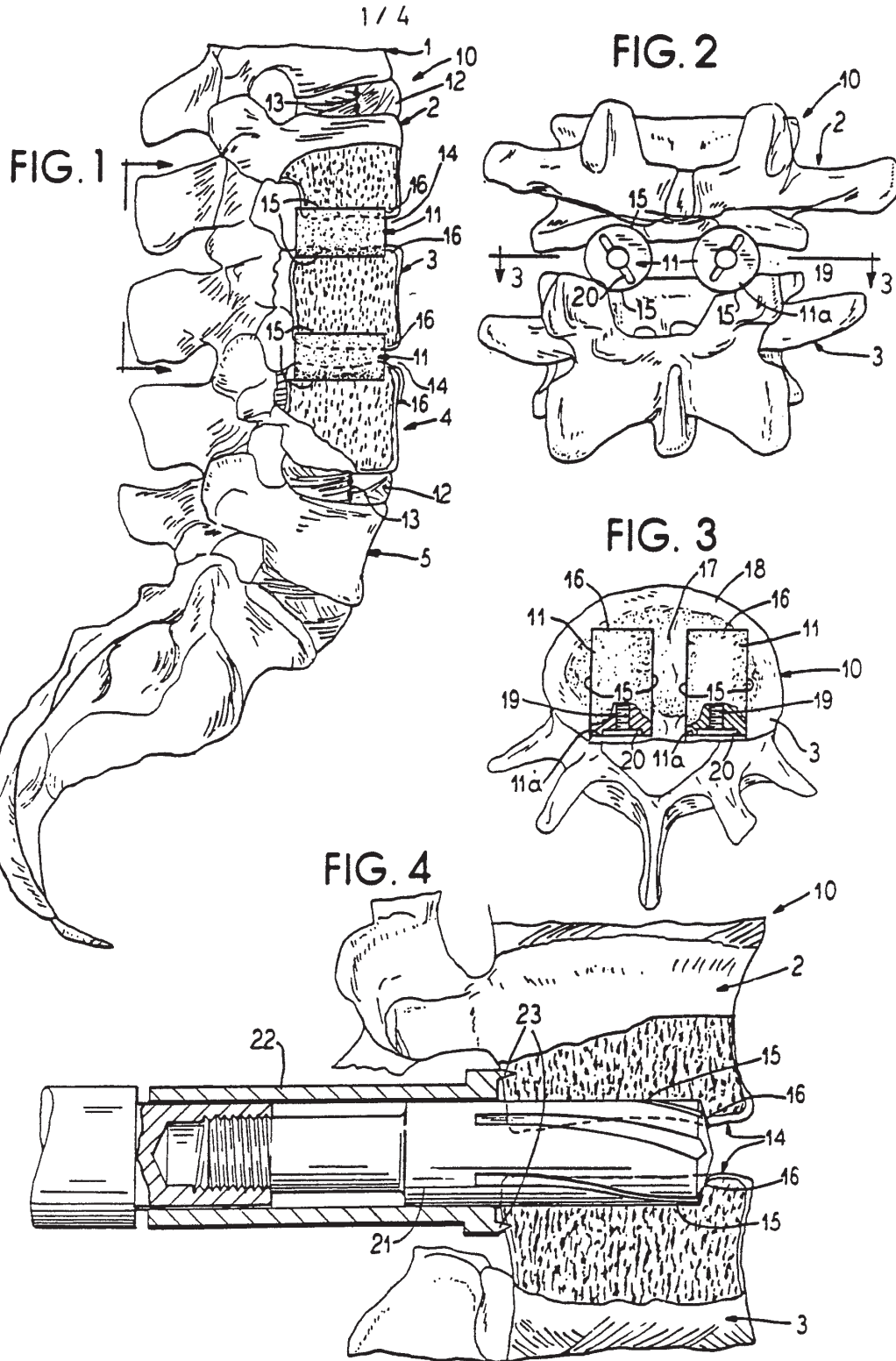

SUBSTITUTE SHEET

2 / 4

FIG. 5

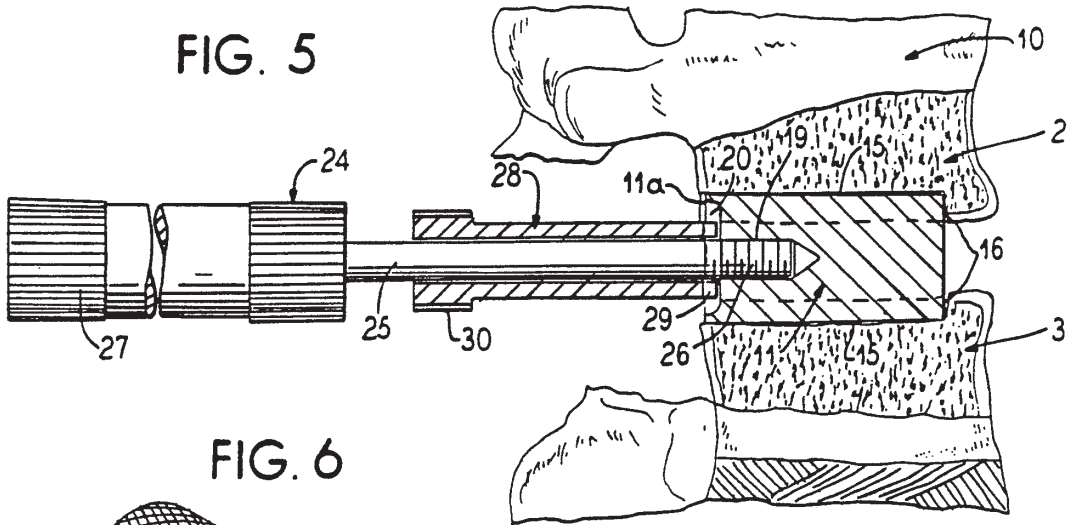

FIG. 6

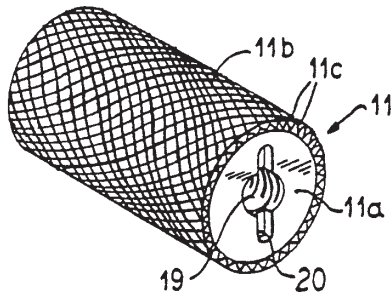

FIG. 7

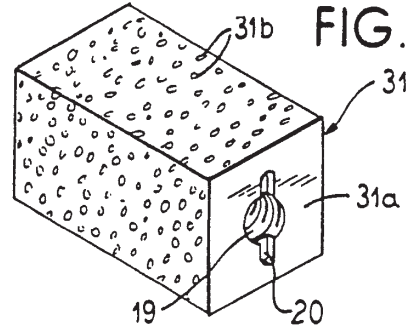

FIG. 8

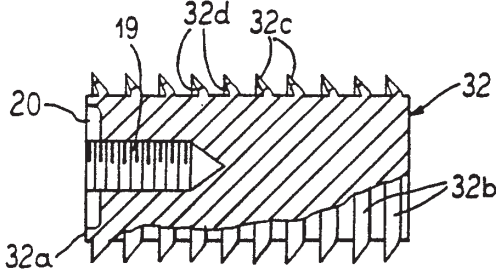

FIG. 9

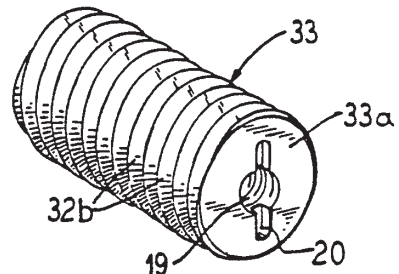

FIG. 10

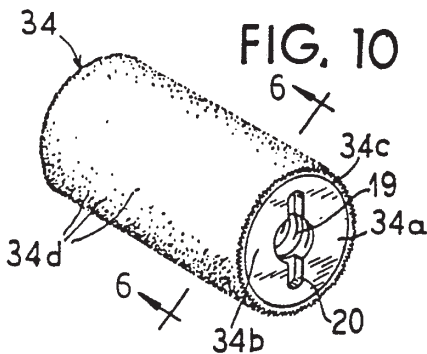
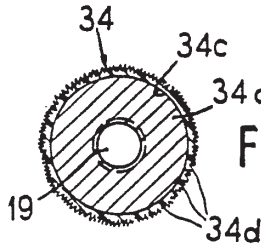

FIG. 11



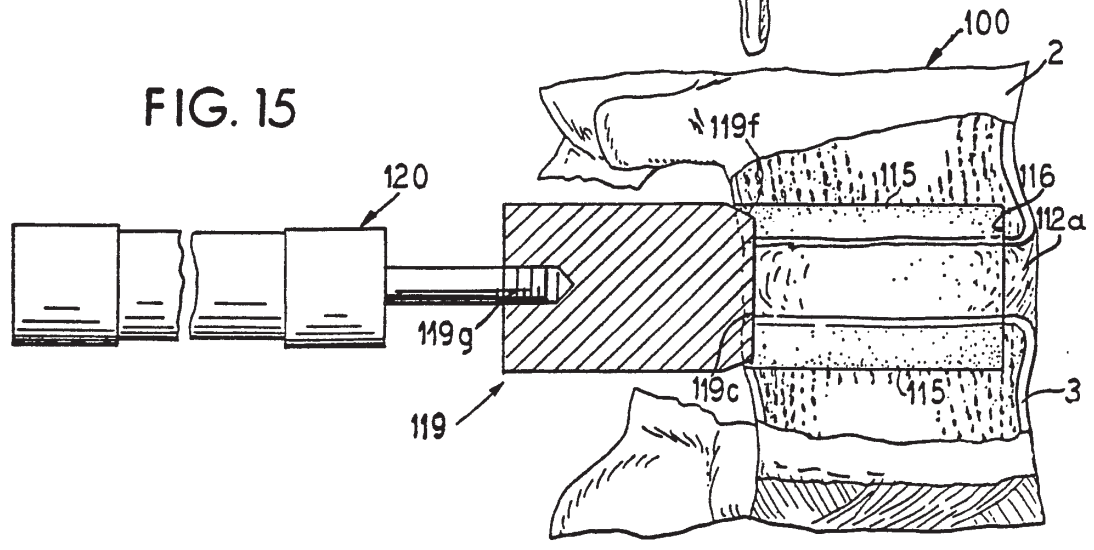
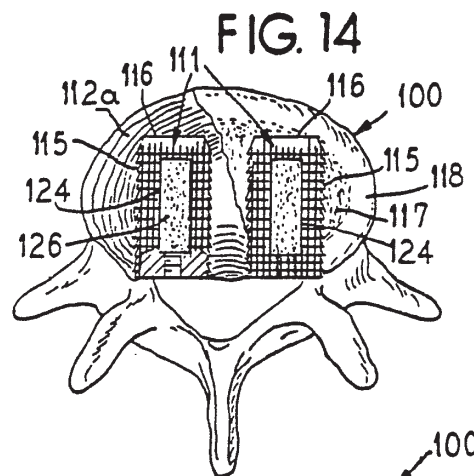
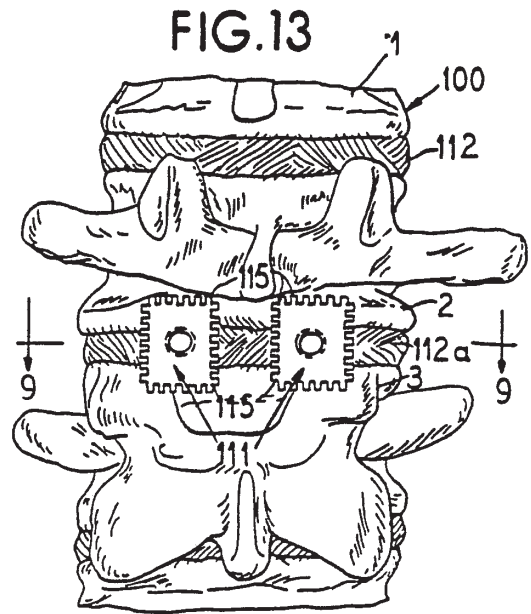
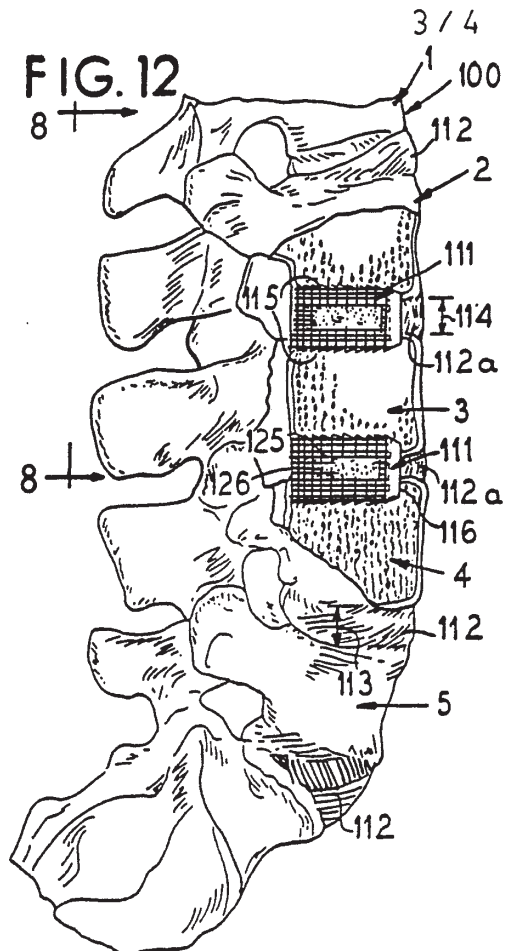

FIG. 16

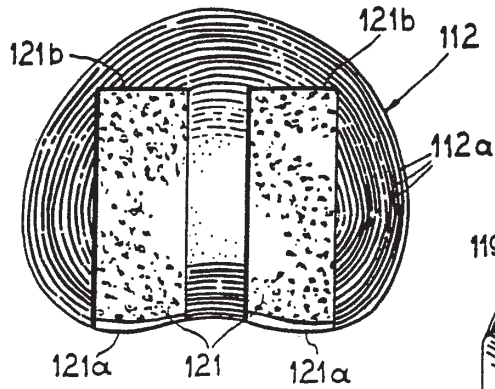

FIG. 17

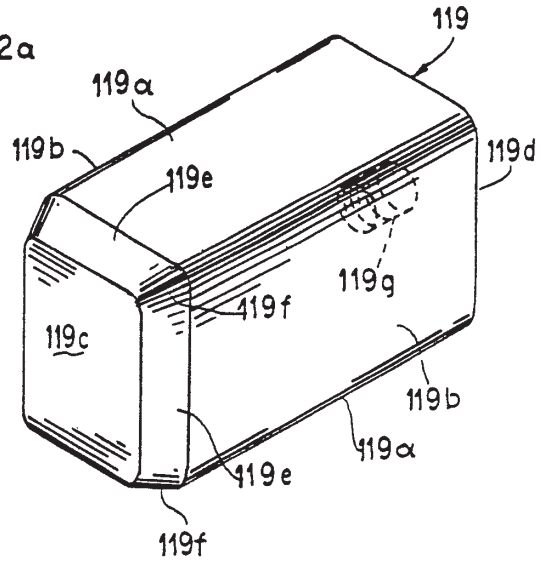

FIG. 18

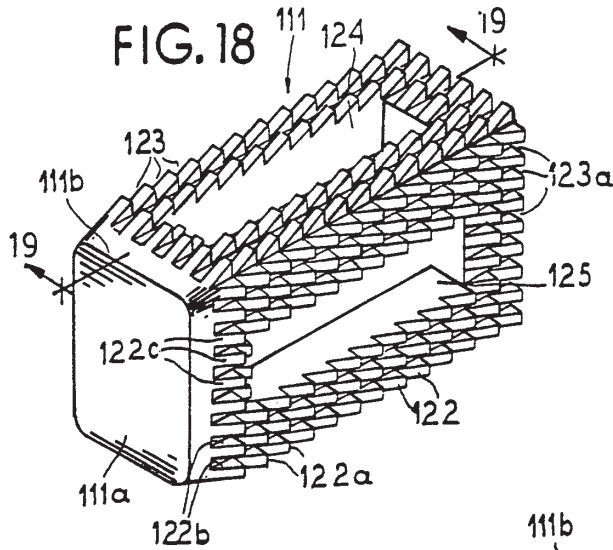
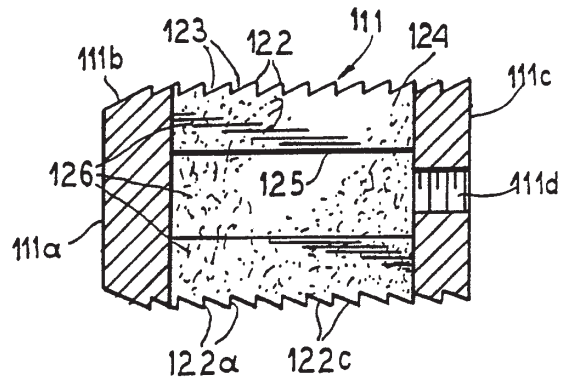



FIG. 19



INTERNATIONAL SEARCH REPORT

International Application No. **PCT/US89/00905**

I. CLASSIFICATION OF SUBJECT MATTER (if several classification symbols apply, indicate all) ⁶		
According to International Patent Classification (IPC) or to both National Classification and IPC		
IPC(4) A61F 2/44 U.S. CLASS 623/17		
II. FIELDS SEARCHED		
Minimum Documentation Searched ⁷		
Classification System	Classification Symbols	
U.S.	623/16-23,66 128/92YJ,92YM,305	
Documentation Searched other than Minimum Documentation to the Extent that such Documents are Included in the Fields Searched ⁸		
III. DOCUMENTS CONSIDERED TO BE RELEVANT ⁹		
Category *	Citation of Document, ¹¹ with indication, where appropriate, of the relevant passages ¹²	Relevant to Claim No. ¹³
Y	US,A, 3,848,601 (MA ET AL.) 19 Nov. 1974, See col. 1, l. 33-67 and col. 5 - col. 8.	1-4,10,12
Y	US,A, 4,349,921 (KUNTZ) 21 Sept. 1982, See Figs 3,15,16, col. 7, l. 52-56.	1-3,5,6,8,9,11-13, 17,19, and 20 -
Y	US,A, 3,228,393 (MICHELE) 11 Jan. 1966, See col. 4, l. 40-45.	15,16
Y	US,A, 3,871,031 (BOUTIN) 18 Mar. 1975, See col. 2, l. 66-68.	5,8,9,17,18
Y	US,A, 3,893,196 (HOCHMAN) 08 Jul. 1975, See col. 1, l. 12-15 and col. 2 l. 32-47.	20,21
<p>* Special categories of cited documents: ¹⁰</p> <p>"A" document defining the general state of the art which is not considered to be of particular relevance</p> <p>"E" earlier document but published on or after the international filing date</p> <p>"L" document which may throw doubts on priority claim(s) or which is cited to establish the publication date of another citation or other special reason (as specified)</p> <p>"O" document referring to an oral disclosure, use, exhibition or other means</p> <p>"P" document published prior to the international filing date but later than the priority date claimed</p> <p>"T" later document published after the international filing date or priority date and not in conflict with the application but cited to understand the principle or theory underlying the invention</p> <p>"X" document of particular relevance; the claimed invention cannot be considered novel or cannot be considered to involve an inventive step</p> <p>"Y" document of particular relevance; the claimed invention cannot be considered to involve an inventive step when the document is combined with one or more other such documents, such combination being obvious to a person skilled in the art.</p> <p>"&" document member of the same patent family</p>		
IV. CERTIFICATION		
Date of the Actual Completion of the International Search	Date of Mailing of this International Search Report	
12 April 1989	22 MAY 1989	
International Searching Authority	Signature of Authorized Officer	
ISA/US	 A. Cannon	