



INTERNATIONAL APPLICATION PUBLISHED UNDER THE PATENT COOPERATION TREATY (PCT)

<p>(51) International Patent Classification⁴ : A61F 2/44</p>	<p>A1</p>	<p>(11) International Publication Number: WO 90/00037 (43) International Publication Date: 11 January 1990 (11.01.90)</p>
--	------------------	--

<p>(21) International Application Number: PCT/US89/02791 (22) International Filing Date: 28 June 1989 (28.06.89) (30) Priority data: 212,480 28 June 1988 (28.06.88) US (71)(72) Applicant and Inventor: MICHELSON, Gary, Karlin [US/US]; 438 Sherman Canal, Venice, CA 90291 (US). (74) Agent: SCHELLIN, Eric, P.; Suite 704, Two Crystal Park, 2121 Crystal Drive, Arlington, VA 22202 (US). (81) Designated States: AT (European patent), AU, BB, BE (European patent), BG, BR, CH (European patent), DE (European patent), DK, FI, FR (European patent), GB (European patent), HU, IT (European patent), JP, KP, KR, LU (European patent), NL (European patent), NO,</p>	<p>RO, SE, SE (European patent). Published <i>With international search report.</i></p>
--	--

(54) Title: ARTIFICIAL SPINAL FUSION IMPLANTS

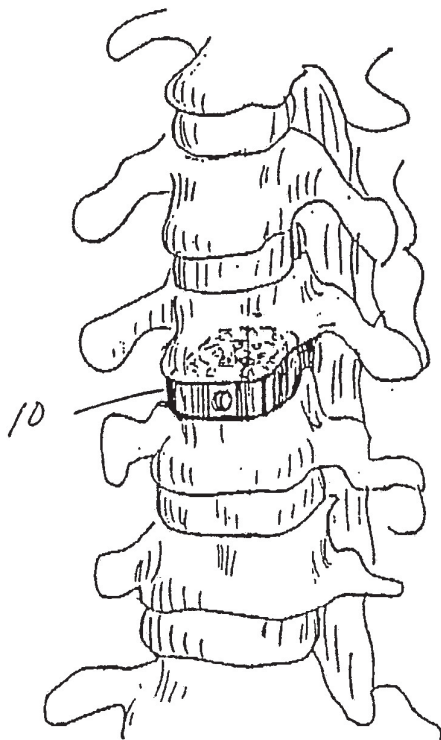

(57) Abstract
A spinal implant (10) is disclosed which when placed within the spinal disc space stabilizes that spinal segment and materially participates in, and is incorporated in the ensuing fusion.

FOR THE PURPOSES OF INFORMATION ONLY

Codes used to identify States party to the PCT on the front pages of pamphlets publishing international applications under the PCT.

AT	Austria	FI	Finland	ML	Mali
AU	Australia	FR	France	MR	Mauritania
BB	Barbados	GA	Gabon	MW	Malawi
BE	Belgium	GB	United Kingdom	NL	Netherlands
BF	Burkina Fasso	HU	Hungary	NO	Norway
BG	Bulgaria	IT	Italy	RO	Romania
BJ	Benin	JP	Japan	SD	Sudan
BR	Brazil	KP	Democratic People's Republic of Korea	SE	Sweden
CF	Central African Republic	KR	Republic of Korea	SN	Senegal
CG	Congo	LJ	Liechtenstein	SU	Soviet Union
CH	Switzerland	LK	Sri Lanka	TD	Chad
CM	Cameroon	LU	Luxembourg	TG	Togo
DE	Germany, Federal Republic of	MC	Monaco	US	United States of America
DK	Denmark	MG	Madagascar		
ES	Spain				

-1-

ARTIFICIAL SPINAL FUSION IMPLANTS

Background

The present invention relates to an artificial fusion implant to be placed into the intervertebral space left after the removal of a damaged spinal disc.

5 The purpose of the present invention is to provide an implant to be placed within the intervertebral disc space and provide for the permanent elimination of all motion at that location. To do so, the device is space occupying within the disc space, rigid, self-stabilizing to
10 resist dislodgement, stabilizing to the adjacent spinal vertebrae to eliminate local motion, and able to intrinsically participate in a vertebra to vertebra bony fusion so as to assure the permanency of the result.

 At present, following the removal of a damaged
15 disc, either bone or nothing is placed into the space left. If nothing is placed in the space the space may collapse which may result in damage to the nerves; or the space may fill with scar tissue and eventually lead to a reherniation. The use of bone is less than optimal in that
20 the bone obtained from the patient requires additional surgery and is of limited availability in its most useful form, and if obtained elsewhere, lacks living bone cells, carries a significant risk of infection, and is also limited in supply as it is usually obtained elsewhere,
25 lacks living bone cells, carries a significant risk of infection, and is also limited in supply as it is usually obtained from young accident victims. Furthermore, regardless of the source of the bone, it is only marginal structurally and lacks a means to either stabilize itself,
30 against dislodgement, or to stabilize the adjacent vertebrae.

 A review of all possibly related prior art will demonstrate the novelty of the present invention.

 There have been an extensive number of attempts
35 to develop an acceptable disc prosthesis (an artificial

-2-

disc). Such devices by design would be used to replace a damaged disc and seek to restore the height of the interspace and to restore the normal motion of that spinal joint. No such device has been found that is medically acceptable. This group of prosthetic or artificial disc replacements seeking to preserve spinal motion which are different from the present invention include:

Patent No. 3,867,728 STUBSTAD - describing a flexible disc implant.

Patent No. 4,349,921 KUNTZ - describing a flexible disc replacement with rope or file like surface projections to discourage device dislocation.

Patent No. 4,309,777 PATIL - describing motion preserving implant with spike outer surfaces to resist dislocation and containing a series of springs to urge the vertebrae away from each other.

Patent No. 3,875,595 FRONING - describing a motion preserving bladder like disc replacement with two opposed stud like projections to resist dislocation.

Patent No. 2,372,622 FRENCH (FASSIO) - describing a motion preserving implant comprising complimentary opposed convex and concave surfaces.

In summary then, these and other similar devices resemble the present invention only in that they are placed within the intervertebral space following the removal of a damaged disc. In that they seek to preserve spinal motion, they are diametrically different from the present invention which seeks to permanently eliminate all motion at that spinal segment.

A second related area of prior art includes those devices utilized to replace essentially wholly removed vertebrae. Such removal is generally necessitated by extensive vertebral fractures, or tumors, and is not associated with the treatment of disc disease, or therefore related to the present invention. While the present invention is to be placed within the disc space, these prior devices cannot be placed within the disc space as at least one vertebrae has already been removed and there no longer remains a "disc space." Furthermore, all of these devices are limited in that they seek to perform as

-3-

temporary structural members mechanically replacing the removed vertebrae (not a removed disc), and do not intrinsically participate in supplying osteogenic material to achieve cross vertebrae bony fusion. Therefore, again
5 unlike the present invention which provides for a source of osteogenesis, use of this group of devices must be accompanied by a further surgery consisting of a bone fusion procedure utilizing conventional technique. This group consisting of vertebral struts rather than disc
10 replacements would include the following:

Patent No. 4,553,273 WU - describing a turnbuckle like vertebral strut.

Patent No. 4,401,112 REZAIAN - describing a turnbuckle like vertebral strut with the addition of a long
15 stabilizing staple that spans the missing vertebral body.

Patent No. 4,554,914 KAPP - describing a large distractible spike that elongates with a screw mechanism to span the gap left by the removal of an entire vertebrae and to serve as an anchor for acrylic cement which is then used
20 to replace the missing bone (vertebrae).

Patent No. 4,636,217 OGILVIE - describing a vertebral strut mechanism that can be implanted after at least one vertebrae has been removed and which device consists of a mechanism for causing the engagement of
25 screws into the vertebrae above the vertebrae below the one removed.

In summary then, this group of devices differs from the present invention in that they are vertebral replacements struts, do not intrinsically participate in
30 the bony fusion, can only be inserted in the limited circumstances where an entire vertebrae has been removed from the anterior approach, and are not designed for, or intended to be used for the treatment of disc disease.

A third area of prior art related to the present
35 invention includes all devices designed to be applied to one of the surfaces of the spine. Such devices include all types of plates, struts, and rods which are attached by hooks, wires, and screws. These devices differ significantly from the present invention in that they are
40 not inserted within the disc space, and furthermore do not

-4-

intrinsically participate in supplying osteogenic material for the fusion.

Therefore, with these devices where permanent spinal immobilization is desired an additional surgery consisting of a spinal fusion performed by conventional means or the use of supplemental methylmethacrylate cement is required. Such devices, applied to the spine but not within the disc space, would include the following:

Patent No. 4,604,995 - STEPHENS - describing a "U" shaped metal rod attached to the posterior elements of the spine with wires to stabilize the spine over a large number of segments.

Patent No. 2,677,369 - KNOWLES - describing a metal column device to be placed posteriorly along the lumbar spine to be held in position by its shape alone and to block pressure across the posterior portions of the spinal column by locking the spine in full flexion thereby shifting the maximum weight back onto the patient's own disc.

Other devices are simply variations on the use of rods (e.g. Harrington, Luque, Cotrel-Dubosset, Zielke), wires or cables (Dwyer), plates and screws (Steffee), or struts (Dunn, Knowles).

In summary, none of these devices are designed for or can be used within the disc space, do not replace a damaged disc, and do not intrinsically participate in the generation of a bony fusion.

Other prior art possibly related to the present invention and therefore, to be considered related to "Bony Ingrowth". Patents related to this feature describe either methods of producing materials or devices to achieve the same. Such patents would include:

Patents No. 4,636,526 (DORMAN), No. 4,634,720 (DORMAN), No. 4,542,539 (ROWE), No. 4,405,319 (COSENTINO), No. 4,439,152 (SMALL), No. 4,168,326 (BROEMER), No. 4,535,485 (ASHMAN), No. 3,987,499 (SCHARBACH), No. 3,605,123 (HAHN), No. 4,655,777 (DUNN), No. 4,645,503 (LIN), No. 4,547,390 (ASHMAN), No. 4,608,052 (VAN KAMPEN), No. 4,698,375 (DORMAN), No. 4,661,536 (DORMAN), No. 3,952,334 (BOKROS), No. 3,905,047 (LONG), No. 4,693,721

-5-

(DUCHEYNE), No. 4,070,514 (ENTHERLY).

However, while the present invention would utilize bone ingrowth technology, it would do so with conventional technology.

5 The final area of related prior art to be considered is that of devices designed to be placed within the vertebral interspace following the removal of a damaged disc, and seeking to eliminate further motion at that location.

10 Such a device is contained in Patent No. 4,501,269 BAGBY describing an implantable device, limited instrumentation, and a method; whereby a hole is bored transversely across the joint and then a hollow metal basket of larger diameter is then pounded into the hole and then filled with the bone debris generated by the drilling. 15 The present invention differs from the prior art devices in the following ways:

1. UNIVERSAL APPLICABILITY WITHOUT CONTOURING OF THE INTERSPACE. The present device will fit any patient, 20 anywhere throughout the spine, in any intervertebral disc space, and without alteration of that interspace regardless of its natural size or shape.

2. RESTORATION AND PRESERVATION OF THE INTERSPACE. The present invention will restore the 25 intervertebral space to its premorbid dimensions, and do so by having the implant fit the space rather than having to modify the interspace, by bone removal from the vertebrae, to accommodate the implant.

3. END PLATE PRESERVATION. Preservation of the 30 highly specialized weight bearing cortical bone is allowed and end plate perforation into the highly vascular cancellous bone marrow with its attendant bleeding is avoided. Such bleeding, when it occurs, bears all the risks of blood loss (e.g. hypoglycemic shock, transfusion transmitted diseases such as hepatitis and acquired immune 35 deficiency syndrome, etc.), and all the complications arising from the resultant impaired visualization of the vital structures (e.g. nerves, blood vessels, and organs due to such bleeding.

40 4. TECHNIQUE. The technique for insertion of

-6-

these implants is consistent with the established methods of disc removal, and requires neither specialized instrumentation nor specialized surgical technique.

5 5. EXTENT OF DISC REMOVAL. The extent of disc removal can be determined by the surgeon at the time surgery and can be individualized for each patient.

6. NO DRILLING. No drilling is involved with the use of the present invention.

10 7. ELIMINATION OF INCORRECT IMPLANT SIZE SELECTION. In those implant systems where a drill is used and significant bone is removed then an estimate of the implant size must first be made, and then, regardless of the fit, an implant at least as large as the space created by the drilling must be utilized, regardless of the quality
15 of that fit. With the present invention no significant bone is removed, and the correct size implants are fitted directly to the interspace eliminating the need to guess at the correct implant size before the fact.

20 8. MODULAR DESIGN. The present implants are available in varying lengths to accommodate the changing depths of the interspace from central to lateral. The devices are available in varying heights or are infinitely adjustable as to the height within the physiological range. The widths are standardized, and the various embodiments
25 can be used in any combination (e.g. in the lumbar spine two auto-expanding implants could be used in conjunction with two anchor deploying implants to completely fill the interspace).

30 9. AVOIDANCE OF SIZE LIMITATIONS. Because in one embodiment the system is modular, component parts can be inserted through a very small opening until a much larger implant is reconstituted completely filling the available interspace; and yet much larger when assembled than the opening through which the component modular
35 sections were introduced. For example, in the lumbar spine four implants introduced one at a time and measuring 8mm in width, would when reconstituted within the interspace constitute a 32mm wide implant. Implantation of a single implant of those dimensions from a posterior approach in
40 the lumbar spine would otherwise be impossible because of

-7-

the presence of the dural sac and spinal nerves.

10. THE AVOIDANCE OF INTERSPACE COLLAPSE. The device is many times stronger than bone and will not collapse. The implantation of the device allows
5 preservation of the very strong vertebral cortex, which is resistant to compression preventing the migration of the implant into the vertebrae. The large surface area of the assembled modular implant, minimizes the load per unit area. For example, a reconstituted lumbar implant of four
10 modular components would have the weight distributed over approximately 8 sq. cm. per vertebral interface.

11. REMOVABILITY. Because the present invention is an interspace implant and not a "through vertebrae" cross interspace implant, removal of the implant, should
15 that become necessary, would not result in iatrogenic destruction of the adjacent vertebrae.

12. SELF-STABILIZING. The implant is self-stabilizing without the use of threads. All of the implants are surface configured to resist dislodgement and
20 the preferred embodiments contain active, mechanical means to assure permanent anchoring. Long term stability begins with the above and is further enhanced by surface treating of the implant for bone ingrowth (by known conventional means) and osteogenically loading the implants.

13. SPINE REDUCING. Various embodiments of the present invention such as the ones with the 180 degree opposed ratcheted surface, and the auto-expanding type, are capable of reducing a vertebral listheses (a forward or
25 backward translation of one vertebrae upon another).k

14. SPINAL STABILITY. These implants are
30 capable of stabilizing a spial segment following disc removal, and do so without the use of threads (threads would be design need to violate the vertebrae themselves extensively).

15. SAFETY. The entire procedure is performed
35 under direct vision and with complete visualization of the adjacent vital structures (e.g. organs, neural structures and blood vessels).

In summary then, the present invention is an interspace implant utilized to replace a damaged disc,
40 which unlike an artificial disc, seeks to permanently

-8-

eliminate rather than to preserve spinal motion, and to do so by a bony fusion. The present invention is clearly an improvement over the prior art providing an interspace implant intrinsically participating in the fusion process, self-stabilizing, stabilizing to the spinal segment, consistent with conventional methods of discectomy, and uniquely consistent with the preservation of the integrity of the adjacent vertebrae.

BRIEF SUMMARY OF THE PRESENT INVENTION

The present invention comprises an artificial implant, the purpose of which is to participate in, and directly cause bone fusion across an intervertebral space following the excision of a damaged disc. Said implants are structurally load bearing devices, stronger than bone, capable of withstanding the substantial forces generated within the spinal interspace. Such devices have a plurality of macro sized cells and openings of 1-3mm, which can be loaded with fusion promoting materials, such as autogenous bone, for the purpose of materially influencing the adjacent vertebrae to perform a bony bond to the implants and to each other. The implant casing may be surface textured or otherwise treated by any of a number of known technologies to achieve a "bone ingrowth surface" to further enhance the stability of the implant and to expedite the fusion. Further, said devices are so configured and designed so as to promote their own stability within the vertebral interspace to resist dislodgement, and furthermore, to stabilize the adjacent vertebrae.

To use the implant of the present invention a conventional discectomy is performed and the vertebral endplates scraped, but not perforated. The appropriately sized implants are loaded with autogenous bone and implanted within the interspace.

For example for an anterior cervical device implantation, a short transverse incision is made across the front of the neck and to the right of the midline directly over the diseased disc. The platysma muscle is split, and the sternocleidomastoid muscle with is split, and the sternocleidomastoid muscle with the carotid sheath

-9-

is protected and retracted laterally. The esophagus, trachea and associated midline structures are protected and retracted medically, thus exposing the anterior aspect of the cervical spine. The diseased disc is identified and removed by conventional surgical methods. The adjacent vertebral endplates are gently scraped free of any remaining cartilage until diffuse fine punctuate decortication is achieved. The dimensions of the interspace are then measured in mild distraction, and the appropriate implant selected. Cancellous bone, obtained from the patient's iliac crest or the equivalent, is loaded into the implant. The safety driver is then utilized to insert the implant behind the anterior lips of the vertebrae. The wound is then closed in the routine manner.

15 Objects of the Present Invention

 It is an object of the present invention to provide for means of achieving interspace fusion and stabilization as a single procedure by a means consistent with the conventional method of discectomy.

20 It is another object of the present invention to provide for a means of achieving an interspace fusion and stabilization that is quicker, safer, and entails less blood loss than by any other known means.

 It is another object of the present invention to provide for means of achieving a one stage interspace fusion and stabilization without significant violation or removal of the adjacent vertebral bone stock.

 It is another object of the present invention to provide for method of intervertebral arthrodesis and stabilization of enhanced safety where the entire procedure is performed under direct vision.

 It is another object of the present invention to provide for a method of intervertebral arthrodesis and stabilization of greater simplicity and requiring minimal specialized instrumentation or technique not already possessed by those doing such procedures by conventional means.

 It is another object of the present invention to provide for modular prosthesis, allowing complimentary

-10-

subunits to be inserted individually through a small opening and to then be reassembled within the interspace, so as to reconstitute an interspace occupying device much larger than would be insertable as a whole.

5 It is another object of the present invention to provide for a modular implant system such that it is possible to precisely fit the contours of any interspace without the need to sacrifice any vertebral bone to accommodate the prosthesis. These and other objects of the present invention will be apparent from review of the following specifications and the accompanying drawings.

Brief description of the Drawings

Figure 1 is a top right perspective view of the implant (cervical type).

15 Figure 1a is a front view of the implant of Fig. 1.

 Figure 1b is a rear view of the implant of Fig. 1.

 Figure 1c is a top view of the implant of Fig. 1.
20 Figure 1d is a side view of the implant of Fig. 1.

 Figure 1e is a bottom view of the implant of Fig. 1.

 Figure 2 is a side sectional view of the implant viewed along lines 2-2 of Fig. 1d.

 Figure 3 is the implant Figure 1 showing the attachment to the driver and driver.

 Figure 4 is a front perspective view showing the implant being driven into the disc space.

30 Figure 4a is a front perspective view of the implant located in the spine.

 Figure 5 is a side view of the implant in the spine attached to the driver.

35 Figure 5a is a close up partial sectional view of the implant and driver.

 Figure 6 is a perspective view of a series of implants placed in the cervical intervertebral space.

 Figure 6A is an alternative embodiment of a rectangular solid implant.

-11-

Figure 7 is a side sectional view of the vertebrae and implant viewed along lines 7-7 of Figure 6.

Figure 7A is a side sectional view of the vertebrae structure showing a third embodiment of the rectangular solid implant in place.

Figure 8 is an exploded perspective view of another embodiment of the present invention.

Figure 9 is a side sectional view of the vertebrae structure and implant viewed along lines 9-9 of Fig. 8.

Figure 10 is a side sectional view of the implant of Figure 8, in a contracted position.

Figure 11 is a side sectional view of the implant of Figure 10, in an expanded position.

Figure 12 is a perspective view of an alternative embodiment of the implant of Figure 9.

Figure 13 is an alternative embodiment of a hollow rectangular solid implant.

Figure 14 is a cross sectional view of the hollow rectangular solid implant of Figure 13 viewed along lines 14-14 of Fig. 13.

Figure 15 is an alternative embodiment of an expandable implant in its extended position.

Figure 16 is an expandable implant of Figure 15 in its retracted position.

Figure 17 is an expandable implant of Figure 16 located in the disc space.

Referring to Figures 1 through 5 an implant for use in the disc space and associated apparatus used for inserting the implant 10 is shown. The implant 10 is shown as a substantially rectangular hollow configuration, having a tapered forward portion.

The implant 10 has an upper surface 12 and a parallel lower surface 14. The two side walls 16 and 18 are parallel to one another and have a series of small sized openings 20 of 1mm-3mm through the side walls 16 and 18.

The front wall 22 is slightly convex and has a depressed portion 24 with a central threaded opening 26 for receiving the engaging end 28 of a driving member 30.

The upper surface 12 has a threaded cap 32, which has opening 33 there through, with a central allen wrench opening 34 for engagement with an allen wrench A of Figure 3. The cap 32 covers the opening into the hollow implant 10 and permits the insertion of autogenous bone material into the hollow portion of the implant 10. The cap 32 is surrounded by a series of small sized openings 36 of 1mm to 3mm passing through the upper surface and into the central hollow portion of the implant 10.

The rear wall 38 is convex so as to conform to the rear of the disc space.

The driving member 30, shown in figure 3, comprises a substantially hollow tubular member 40 having a long internal rod 42 having a turning knob 44 at one end and a threaded portion 46 at the other end for threadably engaging the threaded opening 26 of the implant 10. The engaging end 28 of the driving member 30 has a slightly convex surface to complement the slightly convex surface of the front wall 22. The engaging end 28 has an extension 48 for fitting within the depressed portion 24 on the front wall 22 of the implant 10. The engaging end 28 also has restriction members 47 and 49 to restrict the depth of penetration of the driver 30.

In use, the cap 32 is removed from the implant 10 and autogenous bone material is inserted into the hollow portion of the implant 10. The cap is then replaced. Various methods of packing the implant 10 with the autogenous bone material may be used to obtain a completely packed implant 10.

Referring to Figures 4, 4a, 5 and 5a, the method of inserting the implant is shown. The threaded end 46 of the internal rod 42 of the driving member 30 is attached to the threaded opening 26 of the implant 10 by turning of the knob 44. Once the engaging end 28 is in place, the fitting of the extended portion 48 into the depressed portion 24 prevents movement of the implant 10 in relationship to the driving member 30.

The implant is then placed at the entrance to the disc space between the two adjacent vertebrae V. The knob 44 is then tapped with hammer H sufficiently hard enough to

-13-

drive the implant 10 into the disc space. The restriction members 47 and 49 which are wider than the disc space, prevent over penetration of the implant.

5 The size of the implant 10 is substantially the same size as the disc space that it is replacing and thus will be larger or smaller depending on the disc space in which it is to be used. In the preferred embodiment the implant 10 is approximately 32mm wide.

10 Referring to Figures 4A and 5 the implant 10 is shown in place in the disc space after removal of the driving member once the implant was inserted in place.

15 The autogenous bone material that was packed within the hollow portion of the implant 10 serves to promote bone ingrowth between the implant and the adjacent vertebrae. Once the bone ingrowth occurs, the implant 10 will be a permanent fixture preventing dislodgement of the implant as well as preventing any movement between the adjacent vertebrae.

20 Referring to Figure 6 an alternative embodiment of the implant is disclosed. The implant 61 comprises a substantially rectangular member having a series of ridges 62 on the upper and lower surfaces of the implant 60. One or more grooves 64 are placed on the upper and lower surfaces as well. As indicated in Figure 6, a series of
25 such implants 61 are used as the interbody spinal implant, each placed closely adjacent one another to approximate the size of the removed disc. A series of micro sized opening 63 perforate the implant 61, to promote bone ingrowth.

30 The implant of Figure 6 is inserted as follows: the disc is substantially removed by conventional means. The implants 61 are then inserted in the intervertebral space between the two vertebrae.

35 The size of the implant 61 of Figure 6 is approximately 26 millimeters in length and is wide enough so that four of them will substantially fill the intervertebral space, depending on which vertebrae are fused.

40 In Figure 6a a "bullet nosed" implant 67 having a open front portion 69 to facilitate insertion of implant 67 is shown.

-14-

Referring to Figures 7 and 7a alternative embodiments of the implant 61 of Figure 6 is shown in place between two vertebrae V.

5 In Figure 7 the implant 70 is shown with the ridges 62 shown in the form of teeth facing the anterior. These ridges serve to prevent the implant 60 from 'walking' out of the space between the vertebrae.

10 In Figure 7a an embodiment of the implant 70 of Figure 6 is shown having opposed ridges 72 and 74. This serves to maintain the alignment of the vertebrae when the two vertebrae V are improperly aligned with respect to one another.

15 Referring to Figure 8 an adjustable implant 81 having means for adjusting the width of the implant 81 is shown. The implant 81 comprises a lower member 82 and an upper member 84 which when fitted together form an essentially rectangular implant. The upper member 84 and the lower member 82 have hollow portions that face one another and receive tapered wedges 86 and 88 that fit
20 within the hollow portion of the upper and lower members 82 and 84. The wedges 82 and 84 are such that at their large end they are higher than the combined hollow space between the upper and lower members 84 and 82, and shallower at the other end than the hollow space between the upper and lower
25 members.

The wedges 86 and 88 have a central threaded opening 90 and 92 in alignment with each other for receiving threaded screw 94. Deformable burrs 95 on the head 98 of the screw 94 are used for locking the screw in
30 place. The implant has a series of holes 100 throughout the body of the implant to assist in the ingrowth process.

Referring to Figures 9 through 11 the expandable implant 81 is shown positioned between the two vertebrae V. In Figure 10 the expandable implant 81 is illustrated in
35 its contracted position. The wedges 86 and 88 abutt the interior sloped surfaces 104 of the upper and lower members 82 and 84.

As the screw 94 is turned, as shown in Figure 11, the wedges 86 and 88 are drawn together, and the sloped
40 portions of the wedges force the upper member 82 away from

-15-

the lower member 84. Once the screw 94 has been turned sufficiently, the screw head 98 is hit, causing the deformable burrs to be crimped so as to prevent the reverse rotation of the screw 94.

5 In Figure 12, another alternative embodiment of the expandable implant 81 is illustrated with spike projections 106 extending from the top and bottom members to dig into the vertebrae and assist in maintaining it in place.

10 In use, the disc is removed, and the implant 81 is placed between the vertebrae. The screw 94 is then turned expanding the implant. In the preferred embodiment, the width is from 8 millimeters to 18 millimeters.

15 Referring to Figures 13 and 14, another alternative embodiment of the invention is shown in which the implant 200 comprises a rectangular hollow member having a slightly tapered forward section 202. The cross section, shown in Figure 14, shows the rectangular configuration of the implant.

20 In use of the implant the interior of the implant is filled with a paste made of autogenous bone, and inserted in the place of the former disc. The strength of the material used to make the implant is such that, even though it is substantially hollow, it does have sufficient
25 strength to withstand the forces of the vertebrae compressing the implant.

30 Referring to Figures 15-17, another alternative embodiment is shown in which the implant has movable projections which are movable from a first position within the implant to a second position extending outside of the implant.

35 The implant 300 is of a generally rectangular configuration. The top surface 302 and the bottom surface 304 of the implant have slots 306 for permitting pivotal member 307 having spikes 308 at their ends to project through said slots 306. The spikes 308 are pinned at one end 310 within the implant 300.

40 Opposing wedge shaped members 312 and 314 having a central threaded opening 316 for receiving a threaded screw 318 having a head 320 and a slot 322. The wedges are

-16-

facing each other so that upon turning of the screw will draw the two wedges together, causing the wedges to cause the spikes 308 to pivot about their end 310 and cause the spikes to project out of the implant through the aligned slots 306. The depressions 329 in the pivotal member 307 engage the wedges 314 and 312 to lock the pivotal members 307 in place. A series of holes 324 for promoting bone ingrowth and fusion are provided in the implant 300.

In use, after the removal of the disc material, the implants with the spikes 308 in their withdrawn position, are inserted into the disc space. Then the screw 318 is turned until the spikes 308 are forced to enter the vertebrae material, as shown in Figure 17. The implant 300 is thus held firmly in place.

These implants have a surface configuration so as to induce bone ingrowth through the implant, and into the wall of the vertebrae in effect inducing fusion from one vertebrae V joint to the other, thereby eventually making the implant itself superfluous as the bone would do the work.

The implant itself, because of its being made of stronger material than bone, would provide structural support to the two vertebrae while awaiting bone ingrowth. Once the bone ingrowth occurred, however, the implant would be firmly and permanently fixed in place.

While the invention has been described with regards to the preferred embodiment and a number of alternative embodiments, it is recognized that other embodiments of the present invention may be devised which would not depart from the scope of the present invention.

-17-

What is claimed is:

- 1 1. An implant for fusion of two adjacent
2 vertebrae in the spine said implant comprising a generally
3 rectangular member, said member having a plurality of
4 openings therein for promoting bone ingrowth with the
5 implant and fusion of said vertebrae.

- 1 2. The implant of Claim 1 in which said
2 rectangular member has a plurality of ratchet like members
3 facing in the same direction on the upper and lower
4 surfaces of said member for engagement with adjacent
5 vertebrae.

- 1 3. The implant of Claim 2 in which said ratchet
2 like members on the upper and lower faces face in different
3 directions to prevent movement of the adjacent vertebrae
4 relative to each other.

- 1 4. The implant of Claim 1 in which said implant
2 has a tapered portion at one end.

- 1 5. The implant of Claim 1 in which the
2 rectangular member is separable into an upper portion and a
3 lower portion, and comprises a wedge means fitted between
4 said upper portion and said lower portion for forcing said
5 upper portion away from said lower portion.

- 1 6. The implant of claim 5 in which said wedge
2 means comprises a central threaded opening with a threaded
3 screw connecting two of said wedges, whereby turning said
4 threaded screw draws said wedges together and forces said
5 upper portion and lower portion of said implant away from 6
each other.

- 1 7. The implant of claim 6 in which said implant
2 has a plurality of openings therethrough.

- 1 8. The implant of claim 6 in which said upper
2 and lower surface of said implant has projections for
3 engaging the vertebrae.

-18-

1 9. The implant of claim 1 in which said implant
2 has a plurality of slots in the upper and lower surfaces 3
and a plurality of pivotal members movable between a first 4
position within said implant and a second position outside 5 of
said implant through said slots.

1 10. A spinal implant comprising a hollow
2 rectangular member, said rectangular member having a
3 removable cap for covering said opening.

1 11. The implant of claim 10 in which said
2 implant has a plurality of openings through the walls of
3 said implant.

1 12. The implant of claim 10 in which said
2 implant is substantially the same shape and dimensions as a
3 disc.

1 13. The implant of claim 10 in which said
2 implant comprises a front surface having an threaded
3 opening therein for engagement with a threaded driving
4 member.

1 14. The implant of claim 13 in which said front
2 surface has a driver engaging portion.

1 15. The implant of claim 14 in which said
2 engaging means comprises a depression on the front surface.

1 16. The implant of claim 10 in which said
2 removable cap includes threads for attachment to said
3 implant.

1 17. A driving member for driving a spinal
2 implant comprising a first hollow tubular member, said
3 hollow member having an irregular end for conforming to the
4 external shape of a front surface of a spinal implant, and
5 a second rod member fitted within said hollow tubular
6 member said rod member having a threaded portion at one end
7 and an enlarged knob portion at the other end.

-19-

1 18. The driver member of claim 17 in which said
2 irregular end comprises an extended portion for fitting
3 within a depressed portion of a spinal implant.

1 19. A spinal implant comprising a generally
2 rectangular member having a dimension of less than the width
3 of a disc space, whereby a plurality of said implants of
4 different widths have a width of the size of a disc space.

1 20. A plurality of spinal implants, the combined
2 width of said spinal implants approximating the width of
3 the disc space.

1 21. A method for replacing a disc in the spine
2 comprising removing the disc and inserting into the
3 resulting disc space a plurality of implants having a
4 combined width approximating the width of the disc space.

1 22. The method of claim 21 in which said
2 implants are inserted into the disc space one at a time.

1 23. The method of claim 21 in which said implant
2 is made of a material that promotes bone ingrowth.

1 24. The method of claim 21 including the step of
2 inserting autogenous bone material within said implant
3 before implanting.

1/12

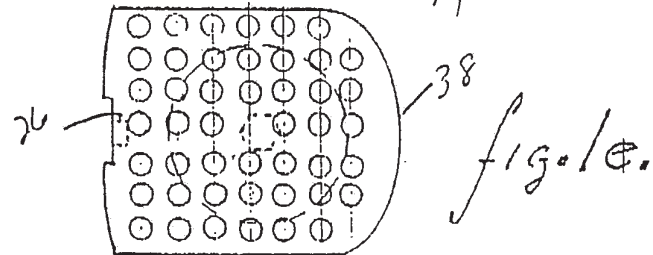
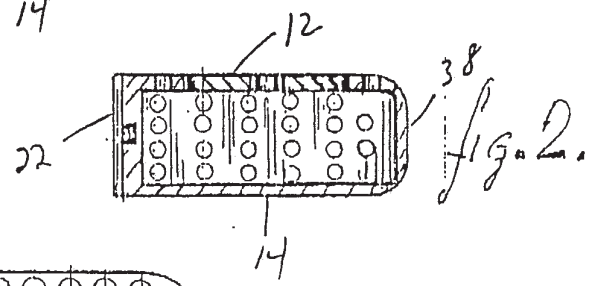
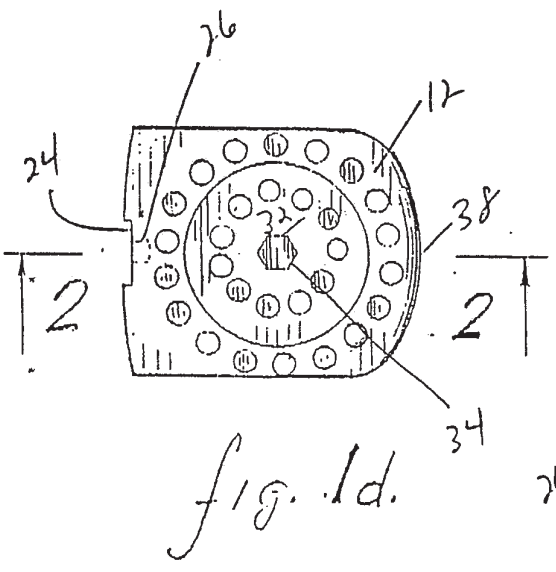
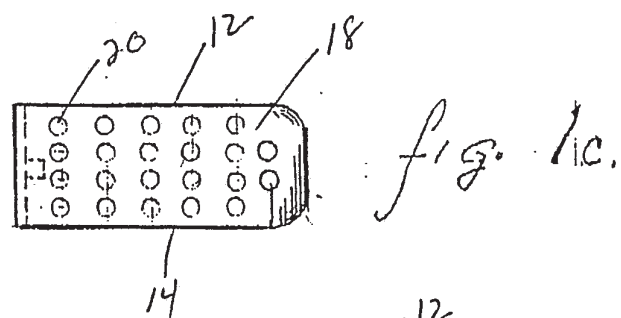
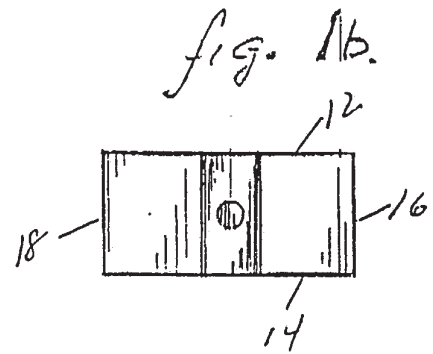
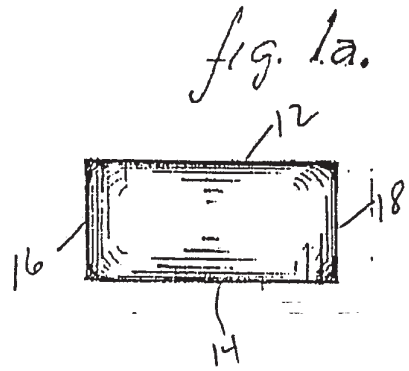
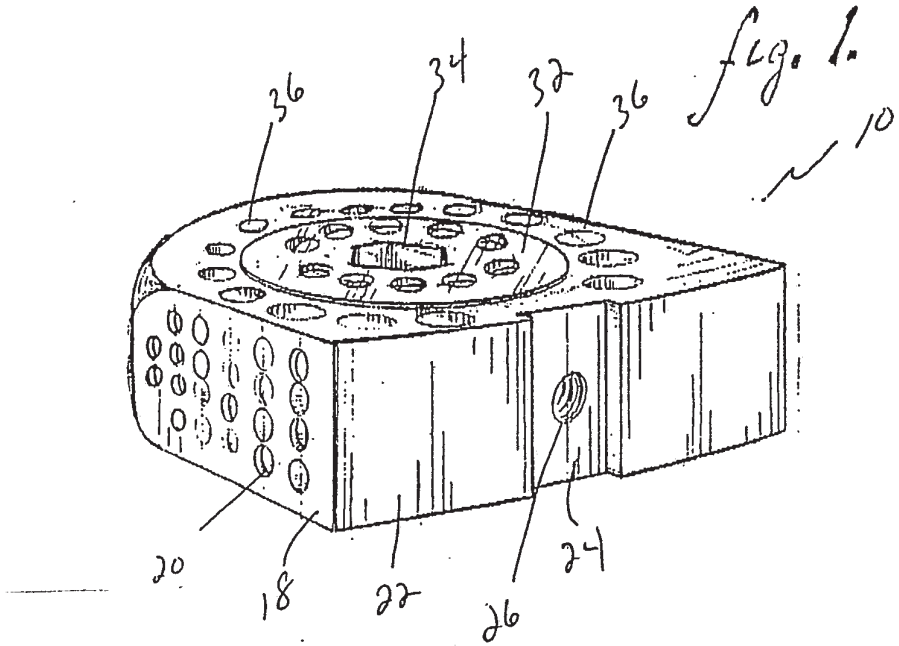

2/12

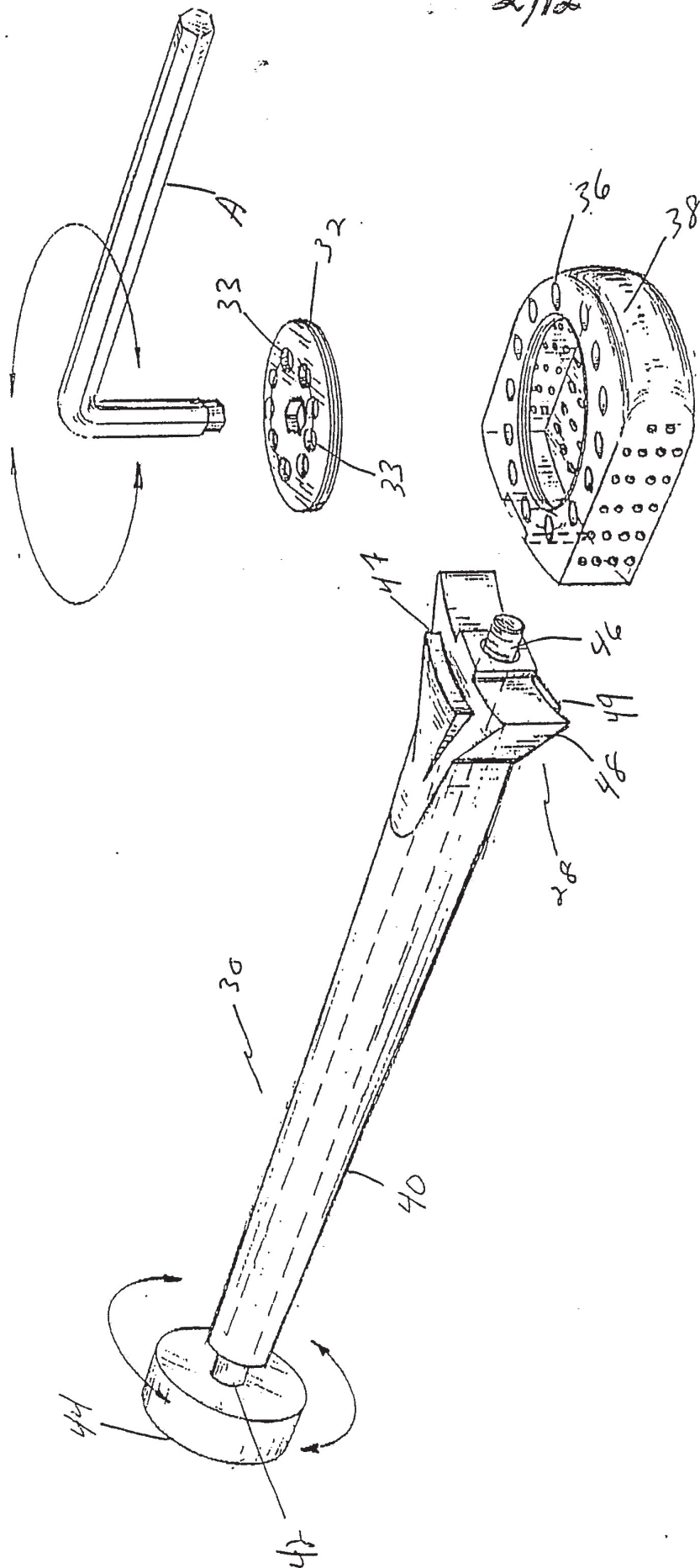

Fig. 3.

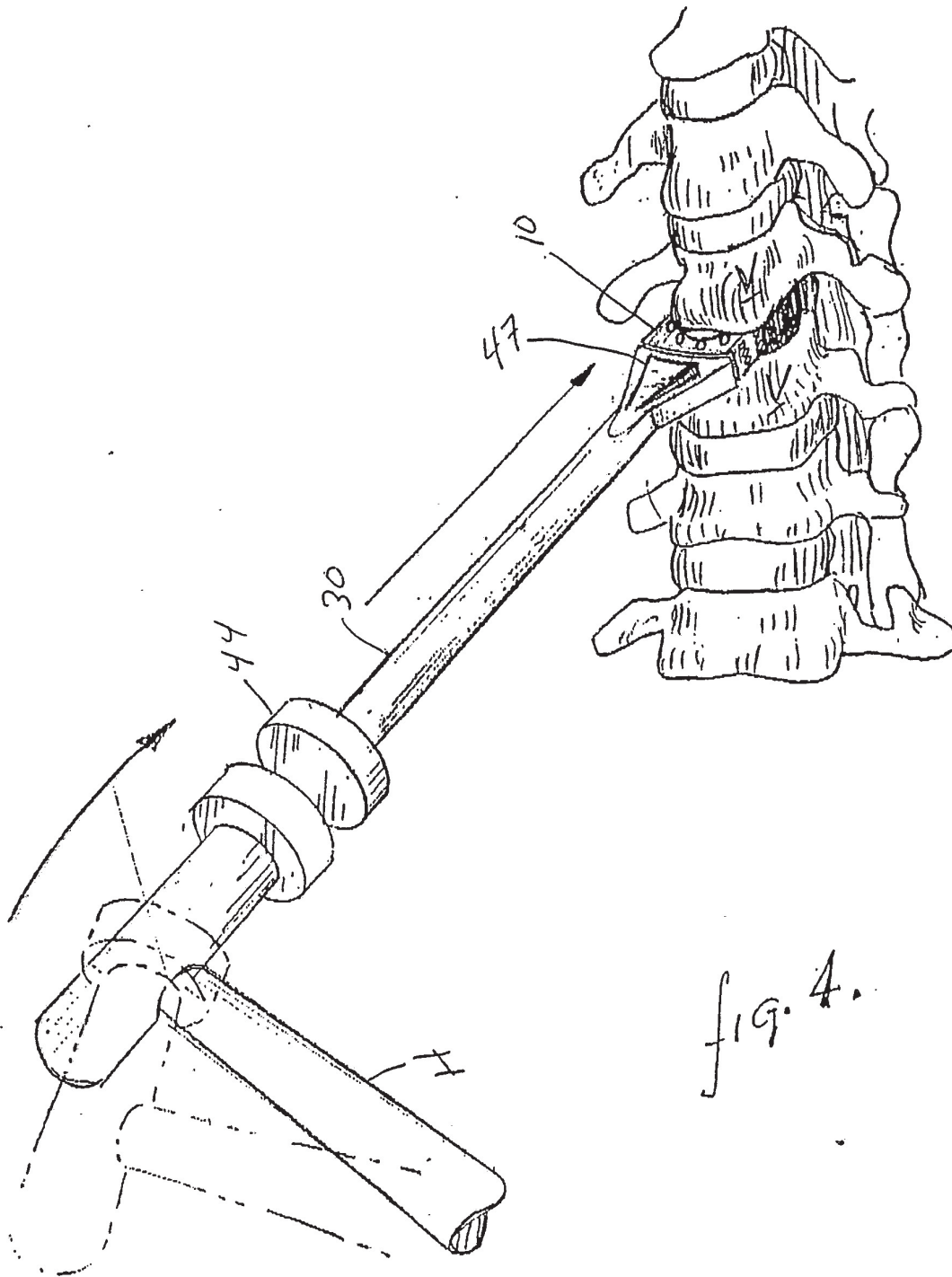

fig. 4.

4/12

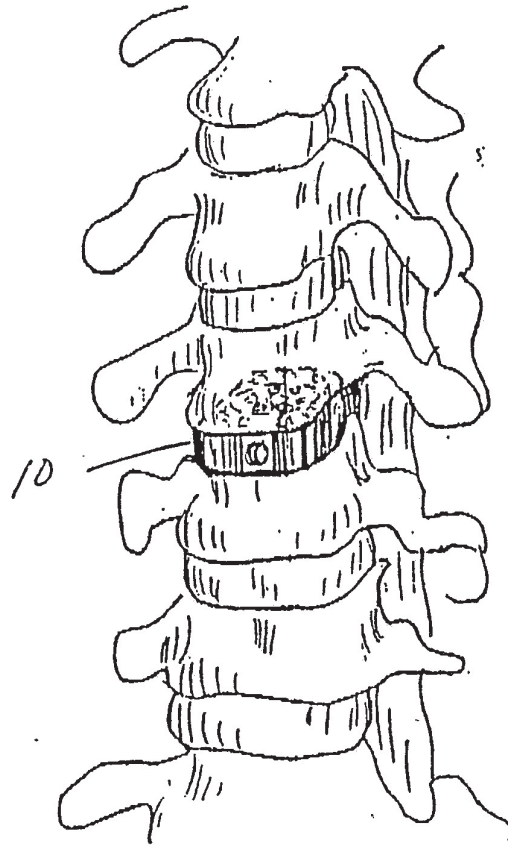

fig. 4a.

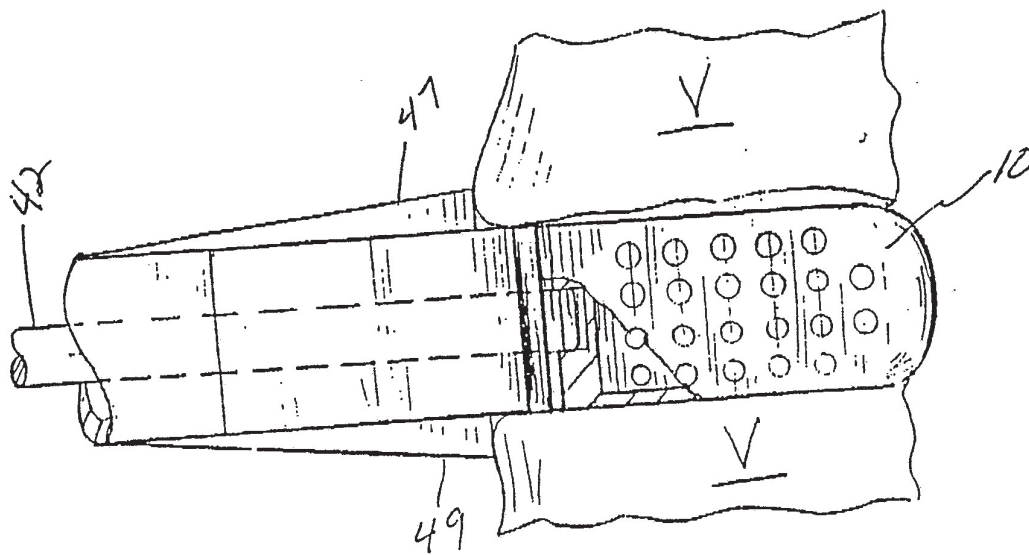
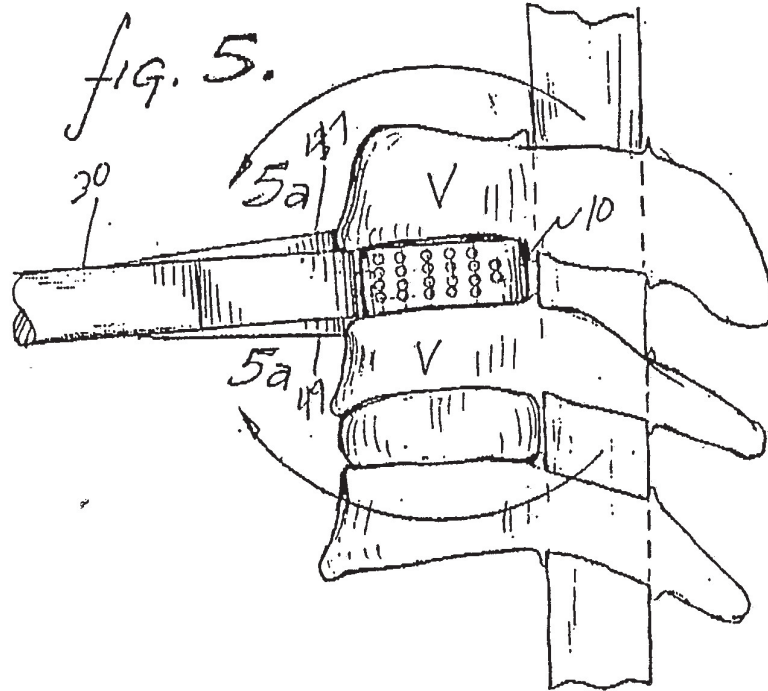

fig. 5a.

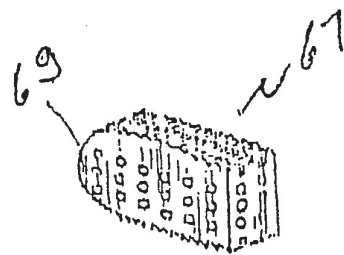
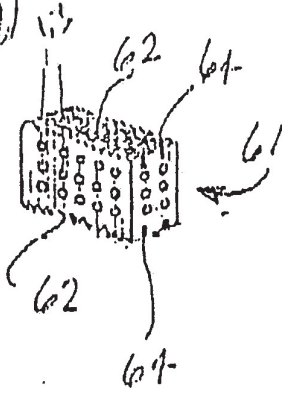
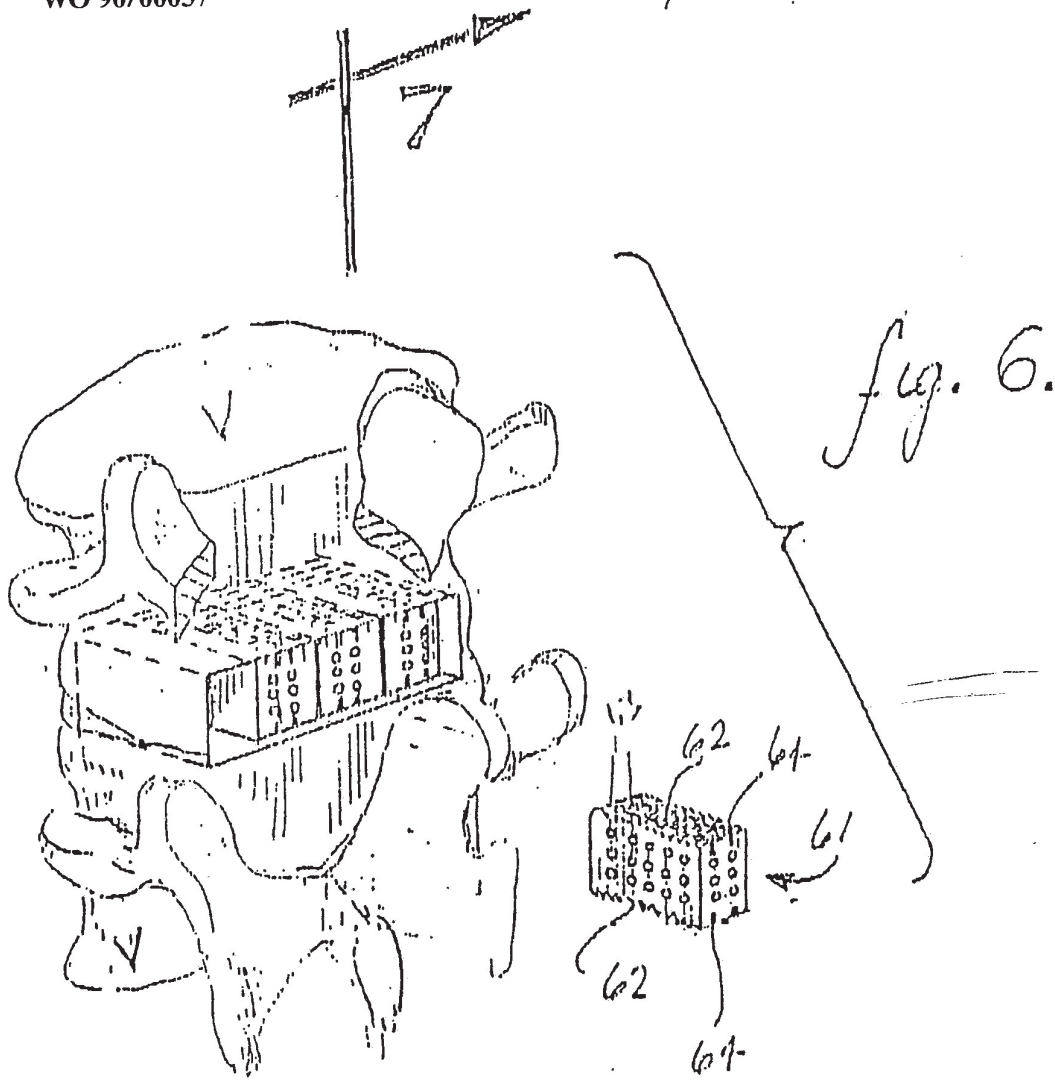

fig. 6A.

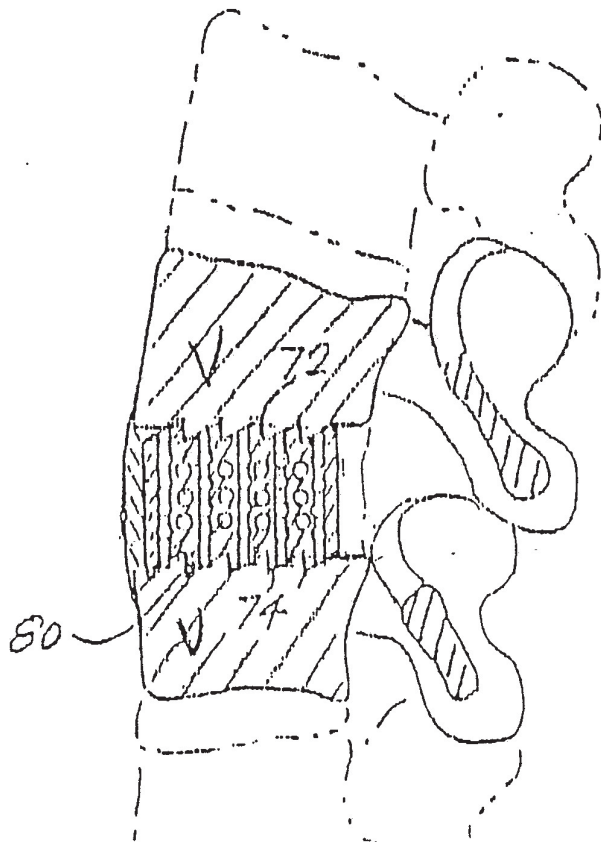
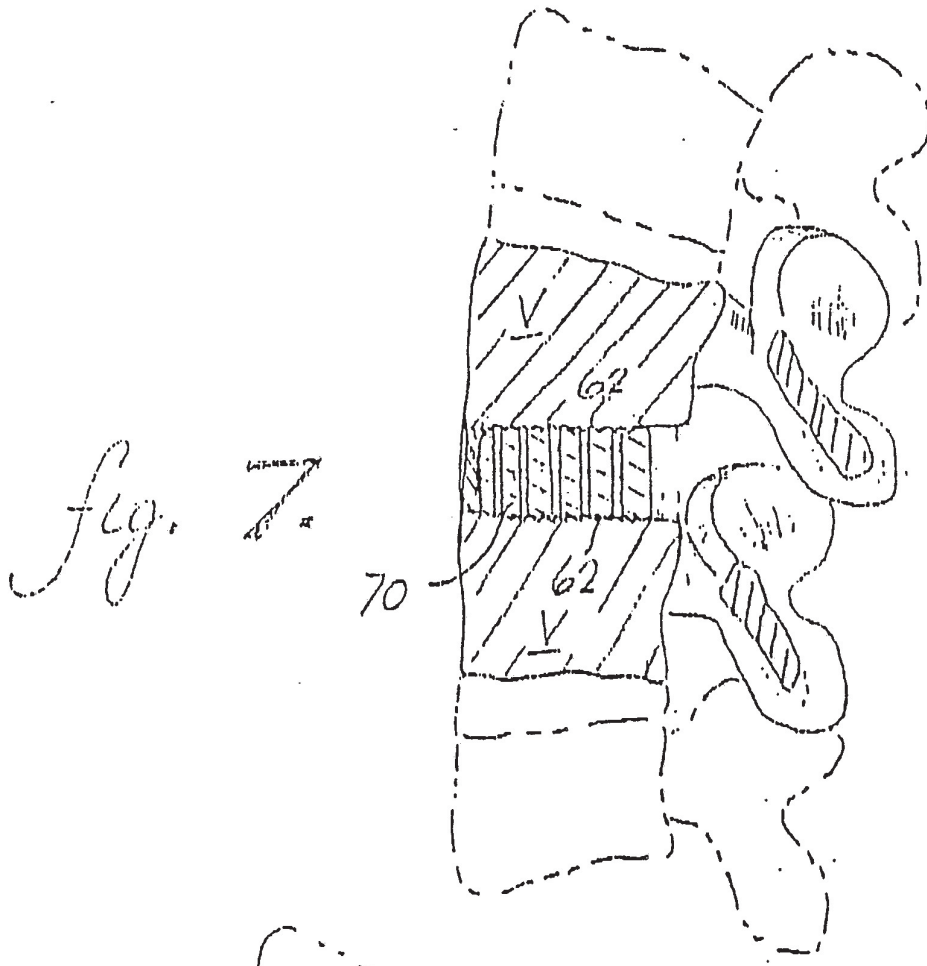
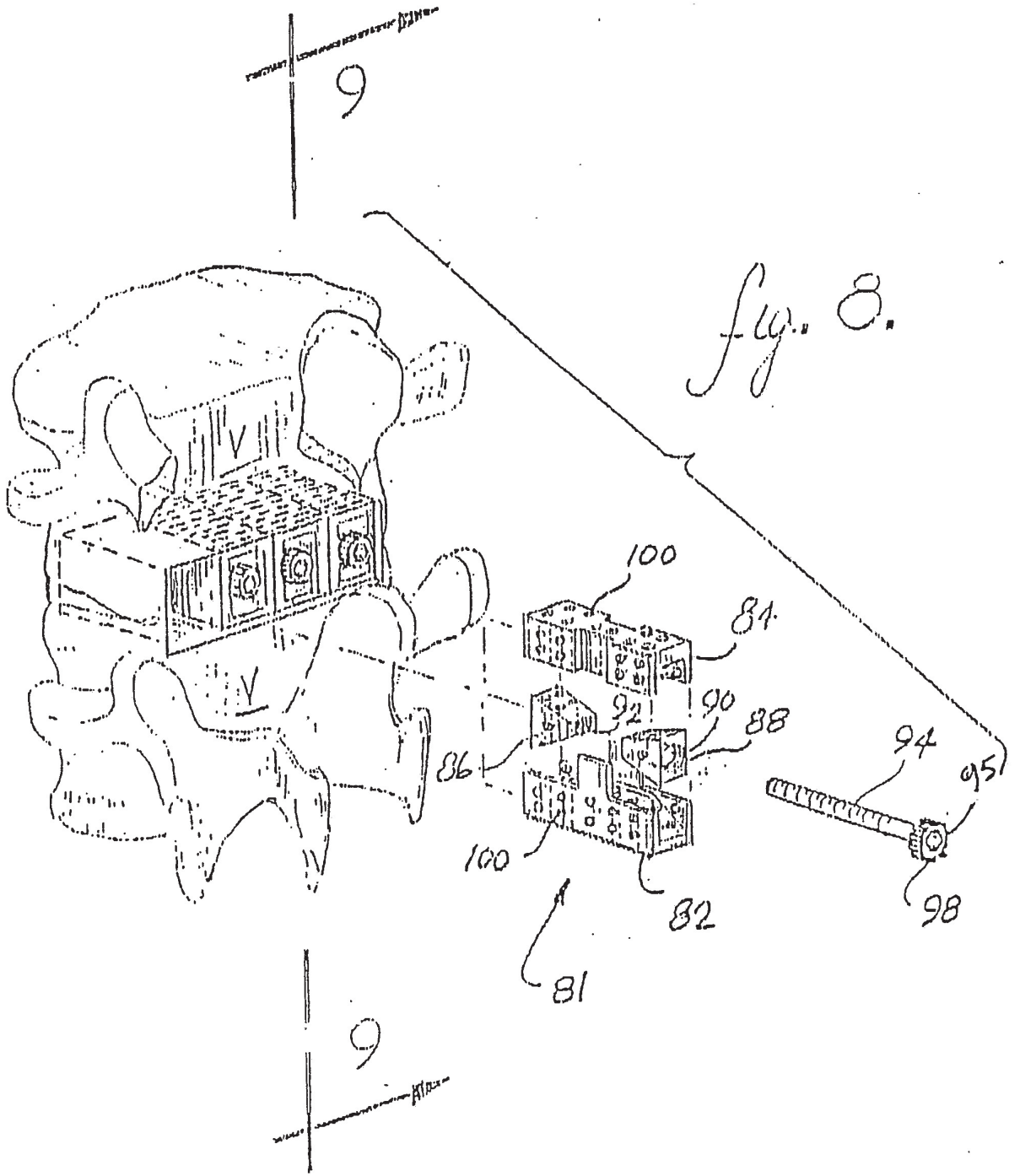

fig. 7A.



9/12

fig. 9.

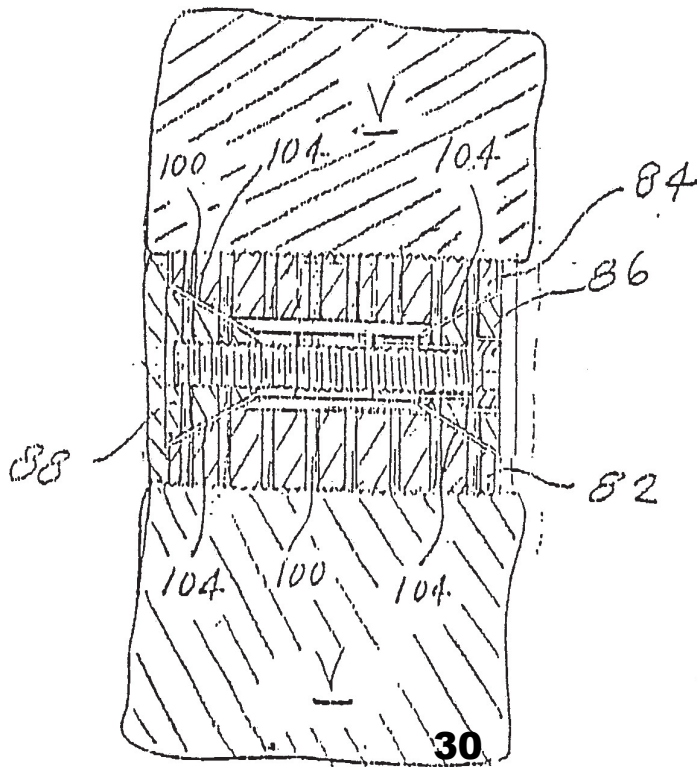
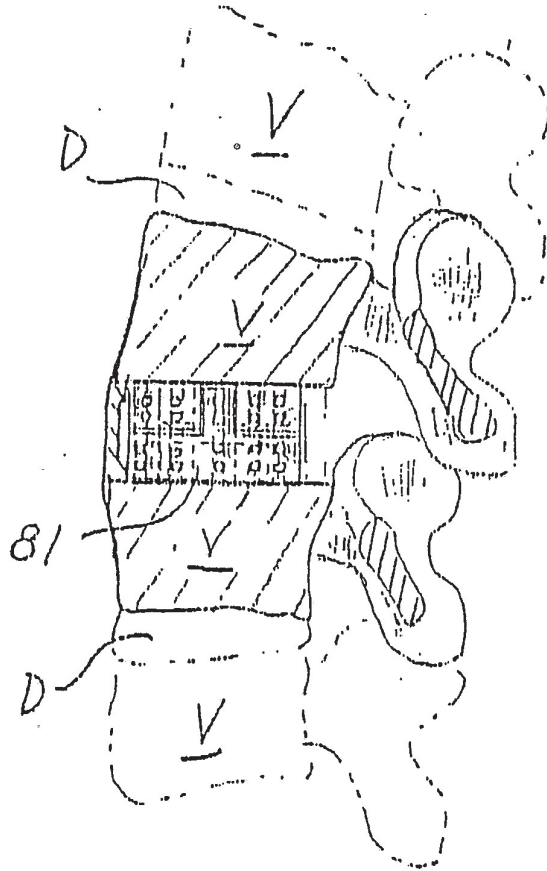

fig. 10.

10/12

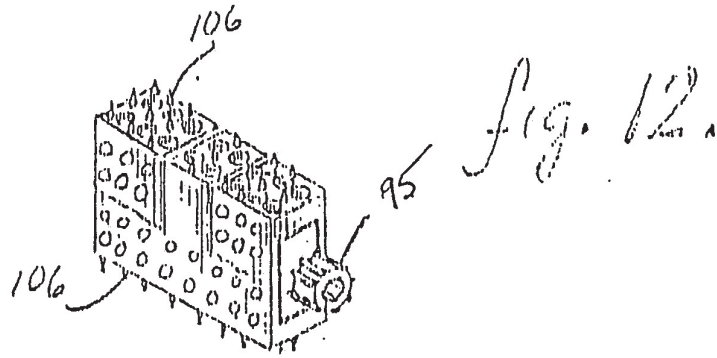

Fig. 13.

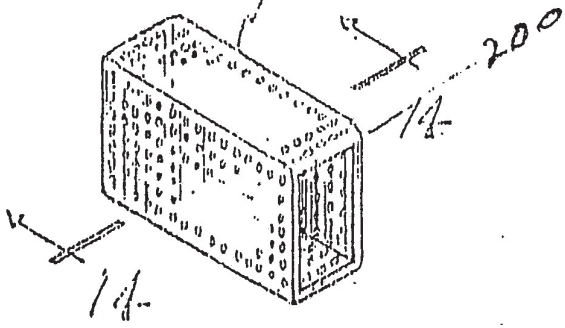

Fig. 14.

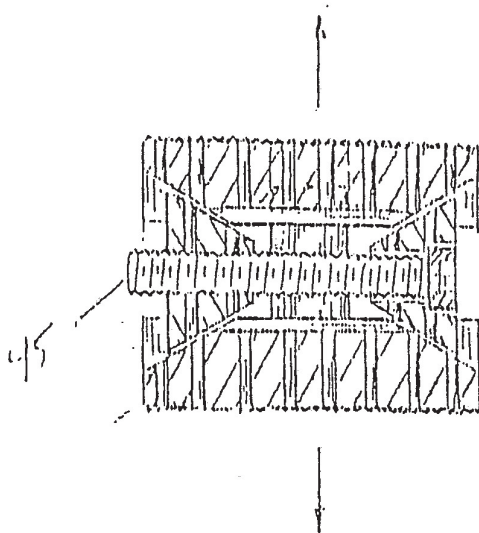
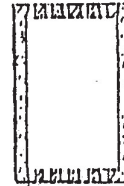

Fig. 11.

11/12

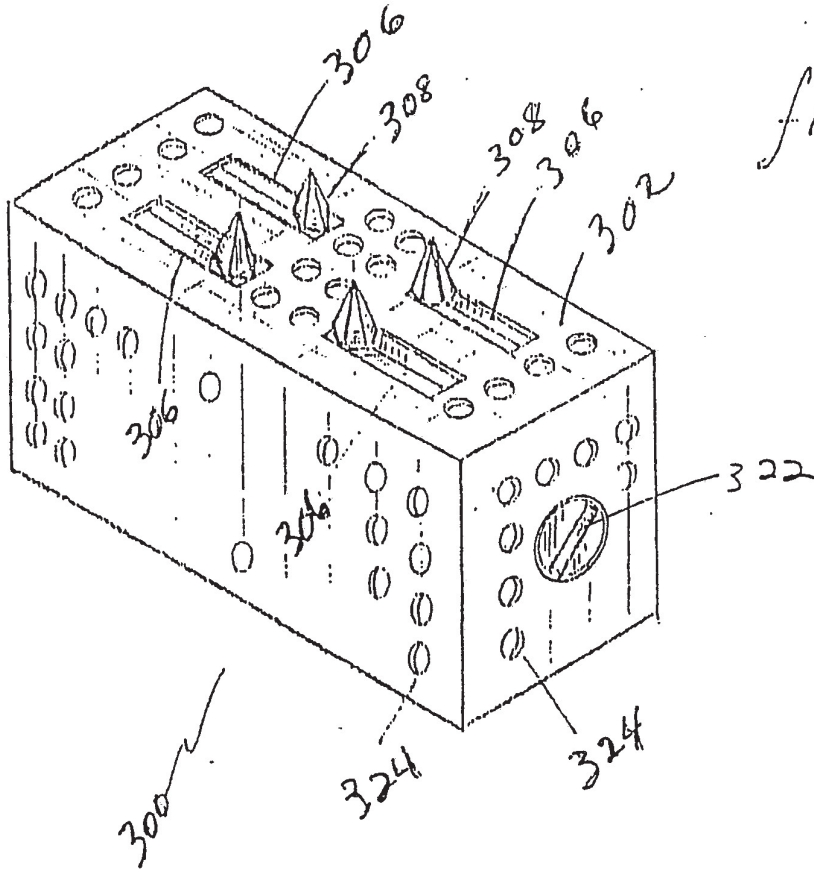

fig. 15.

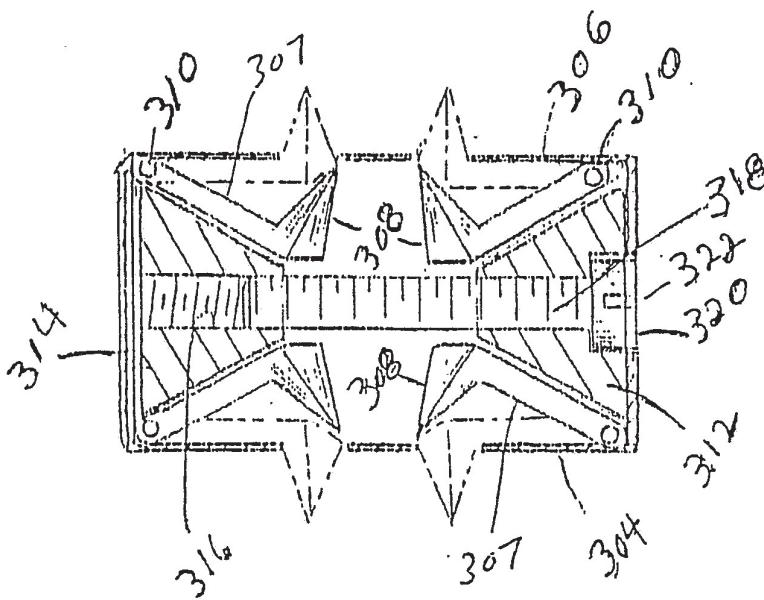
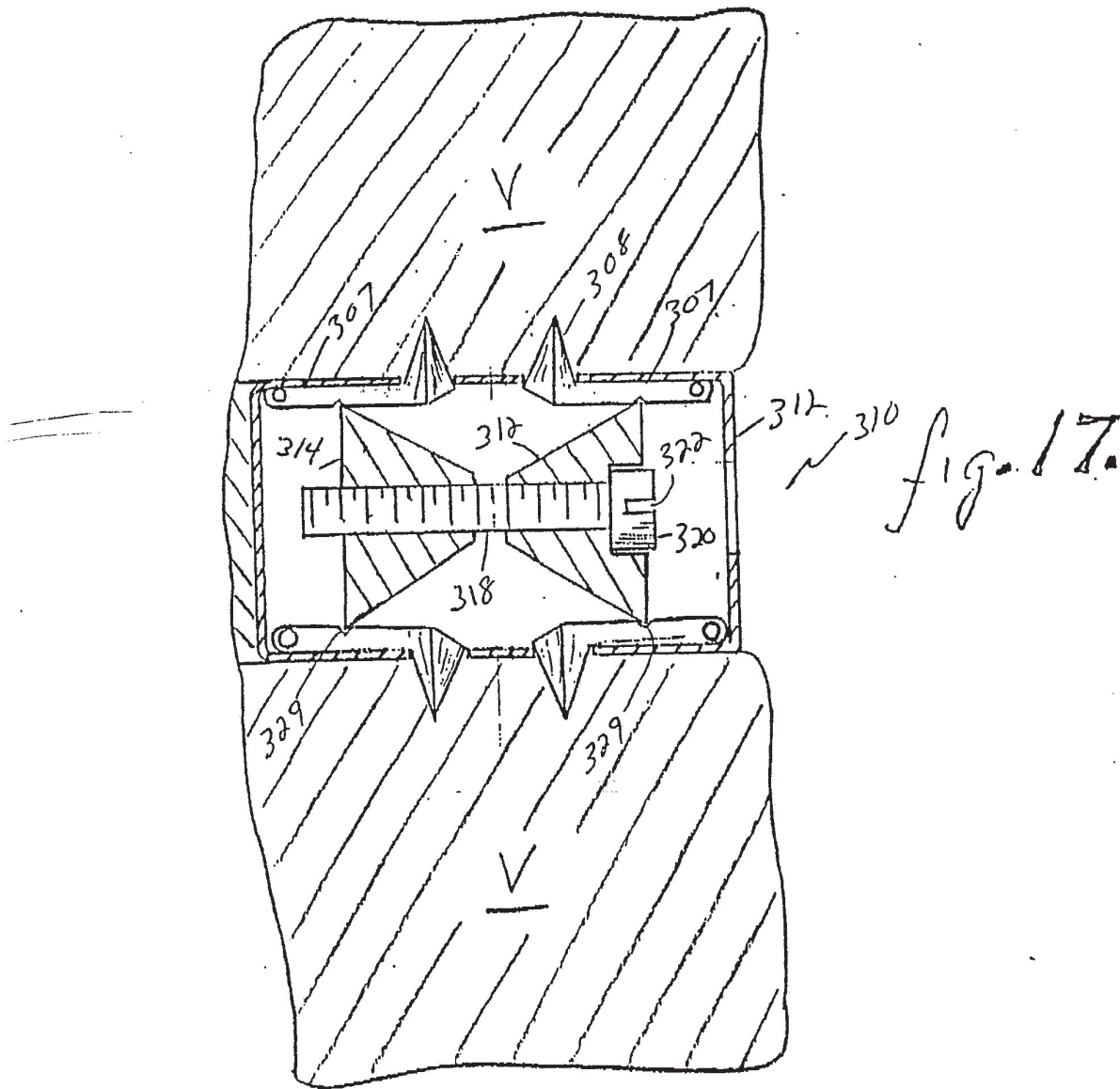



fig. 16.

12/12



INTERNATIONAL SEARCH REPORT

International Application No. PCT/US89/02791

I. CLASSIFICATION OF SUBJECT MATTER (if several classification symbols apply, indicate all) ⁶		
According to International Patent Classification (IPC) or to both National Classification and IPC		
IPC (4): A61F 2/44 U.S. Cl. 623/17		
II. FIELDS SEARCHED		
Minimum Documentation Searched ⁷		
Classification System	Classification Symbols	
U.S.	623/16, 17; 128/69, 92YM, 92YY, 92VT; 604/93, 890.1, 891.1, 892	
Documentation Searched other than Minimum Documentation to the Extent that such Documents are Included in the Fields Searched ⁸		
III. DOCUMENTS CONSIDERED TO BE RELEVANT ⁹		
Category [*]	Citation of Document, ¹¹ with indication, where appropriate, of the relevant passages ¹²	Relevant to Claim No. ¹³
X, P Y, P	US, A, 4,834,757 (BRANTIGAN) 30 May 1989 See Figures; column 6, lines 51-56; column 6, line 66-column 7, line 5.	1-2, 4 3, 5-16, 24
Y	EP, A, 0,260,044 (SHEPPERD) 16 March 1988 See Figures.	5-9
Y	US, A, 4,721,103 (FREEDLAND) 26 January 1988, see Figures.	9
Y	US, A, 4,599,086 (DOTY) 08 July 1986 See Figures.	9
Y	US, A, 3,948,262 (ZAFFARONI) 06 April 1976, see column 7, line 51-column 8, line 24.	10-16
Y	US, A, 4,507,115 (KAMBARA ET AL) 26 March 1985, see Figures; column 1, lines 12-18; column 2, lines 9-11.	10-16
X Y	US, A, 4,714,469 (KENNA) 22 December 1987 See Figures.	17-18, 21-23 24
<p>[*] Special categories of cited documents: ¹⁰</p> <p>"A" document defining the general state of the art which is not considered to be of particular relevance</p> <p>"E" earlier document but published on or after the international filing date</p> <p>"L" document which may throw doubts on priority claim(s) or which is cited to establish the publication date of another citation or other special reason (as specified)</p> <p>"O" document referring to an oral disclosure, use, exhibition or other means</p> <p>"P" document published prior to the international filing date but later than the priority date claimed</p> <p>"T" later document published after the international filing date or priority date and not in conflict with the application but cited to understand the principle or theory underlying the invention</p> <p>"X" document of particular relevance; the claimed invention cannot be considered novel or cannot be considered to involve an inventive step</p> <p>"Y" document of particular relevance; the claimed invention cannot be considered to involve an inventive step when the document is combined with one or more other such documents, such combination being obvious to a person skilled in the art.</p> <p>"&" document member of the same patent family</p>		
IV. CERTIFICATION		
Date of the Actual Completion of the International Search	Date of Mailing of this International Search Report	
22 August 1989	27 SEP 1989	
International Searching Authority	Signature of Authorized Officer	
ISA/US	 David J. Bender	

FURTHER INFORMATION CONTINUED FROM THE SECOND SHEET

X

US, A, 4,349,921 (KUNTZ) 21 September 1982
See Figures 7-10; column 6, lines
39-42.

19-23

V. OBSERVATIONS WHERE CERTAIN CLAIMS WERE FOUND UNSEARCHABLE ¹

This international search report has not been established in respect of certain claims under Article 17(2) (a) for the following reasons:

1. Claim numbers _____, because they relate to subject matter ¹² not required to be searched by this Authority, namely:
2. Claim numbers _____, because they relate to parts of the international application that do not comply with the prescribed requirements to such an extent that no meaningful international search can be carried out ¹³, specifically:
3. Claim numbers _____, because they are dependent claims not drafted in accordance with the second and third sentences of PCT Rule 6.4(a).

VI. OBSERVATIONS WHERE UNITY OF INVENTION IS LACKING ²

This International Searching Authority found multiple inventions in this international application as follows:

1. As all required additional search fees were timely paid by the applicant, this international search report covers all searchable claims of the international application.
2. As only some of the required additional search fees were timely paid by the applicant, this international search report covers only those claims of the international application for which fees were paid, specifically claims:
3. No required additional search fees were timely paid by the applicant. Consequently, this international search report is restricted to the invention first mentioned in the claims; it is covered by claim numbers:
4. As all searchable claims could be searched without effort justifying an additional fee, the International Searching Authority did not invite payment of any additional fee.

Remark on Protest

- The additional search fees were accompanied by applicant's protest.
- No protest accompanied the payment of additional search fees.