



US007385756B2

(12) **United States Patent**
Shafer et al.

(10) **Patent No.:** **US 7,385,756 B2**
(45) **Date of Patent:** **Jun. 10, 2008**

(54) **CATADIOPTRIC PROJECTION OBJECTIVE**

FOREIGN PATENT DOCUMENTS

(75) Inventors: **David Shafer**, Fairfield, CT (US);
Wilhelm Ulrich, Aalen (DE); **Aurelian Dodoc**, Heidenheim (DE); **Rudolf Von Buenau**, Jena (DE); **Hans-Juergen Mann**, Oberkochen (DE); **Alexander Epple**, Aalen (DE)

DE 1064734 B 9/1959

(Continued)

OTHER PUBLICATIONS

(73) Assignee: **Carl Zeiss SMT AG**, Oberkochen (DE)

M. H. Freeman, Innovative Wide-Field Binocular Design, OSA Proceedings of the International Optical Design Conference, 1994, pp. 389-393, vol. 22.

(*) Notice: Subject to any disclaimer, the term of this patent is extended or adjusted under 35 U.S.C. 154(b) by 0 days.

(Continued)

(21) Appl. No.: **11/035,103**

Primary Examiner—Stephone B. Allen

(22) Filed: **Jan. 14, 2005**

Assistant Examiner—Lee Fineman

(74) *Attorney, Agent, or Firm*—Fish & Richardson P.C.

(65) **Prior Publication Data**

(57) **ABSTRACT**

US 2005/0190435 A1 Sep. 1, 2005

Related U.S. Application Data

(60) Provisional application No. 60/617,674, filed on Oct. 13, 2004, provisional application No. 60/612,823, filed on Sep. 24, 2004, provisional application No. 60/587,504, filed on Jul. 14, 2004, provisional application No. 60/536,248, filed on Jan. 14, 2004.

A catadioptric projection objective for imaging a pattern provided in an object plane of the projection objective onto an image plane of the projection objective comprises: a first objective part for imaging the pattern provided in the object plane into a first intermediate image; a second objective part for imaging the first intermediate image into a second intermediate image; a third objective part for imaging the second intermediate image directly onto the image plane; wherein a first concave mirror having a first continuous mirror surface and at least one second concave mirror having a second continuous mirror surface are arranged upstream of the second intermediate image; pupil surfaces are formed between the object plane and the first intermediate image, between the first and the second intermediate image and between the second intermediate image and the image plane; and all concave mirrors are arranged optically remote from a pupil surface. The system has potential for very high numerical apertures at moderate lens material mass consumption.

(51) **Int. Cl.**

G02B 17/00 (2006.01)

G02B 21/00 (2006.01)

(52) **U.S. Cl.** **359/365; 359/730**

(58) **Field of Classification Search** None
See application file for complete search history.

(56) **References Cited**

U.S. PATENT DOCUMENTS

2,380,887 A 7/1945 Warmisham
3,244,073 A 4/1966 Bouwers et al.

(Continued)

109 Claims, 33 Drawing Sheets

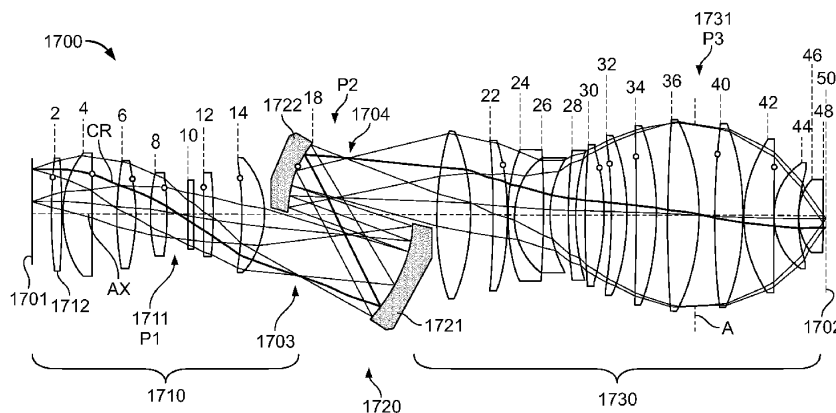

U.S. PATENT DOCUMENTS			FOREIGN PATENT DOCUMENTS		
4,103,990 A	8/1978	Yamada	7,030,965 B2	4/2006	Takahashi
4,241,390 A	12/1980	Markle et al.	7,075,726 B2	7/2006	Terasawa et al.
4,293,186 A	10/1981	Offner	7,079,314 B1	7/2006	Suenaga et al.
4,346,164 A	8/1982	Tabarelli et al.	7,085,075 B2	8/2006	Mann et al.
4,398,809 A	8/1983	Canzek	7,092,168 B2	8/2006	Terasawa et al.
4,443,068 A	4/1984	Itoh	7,187,503 B2	3/2007	Rostalski et al.
4,469,414 A	9/1984	Shafer	7,190,530 B2	3/2007	Mann et al.
4,482,219 A	11/1984	Canzek	7,218,445 B2	5/2007	Shafer et al.
4,666,259 A	5/1987	Iizuka	7,224,520 B2	5/2007	Mitchell
4,685,777 A	8/1987	Hirose	7,237,915 B2	7/2007	Hudyma
4,711,535 A	12/1987	Shafer	7,239,453 B2	7/2007	Terasawa et al.
4,757,354 A	7/1988	Sato et al.	2002/0024741 A1	2/2002	Terasawa et al.
4,779,966 A	10/1988	Friedman	2002/0176063 A1 *	11/2002	Omura 355/67
4,812,028 A	3/1989	Matsumoto	2003/0197922 A1	10/2003	Hudyma
4,834,515 A	5/1989	Mercado	2003/0234912 A1	12/2003	Omura
4,861,148 A	8/1989	Sato et al.	2003/0234992 A1	12/2003	Shafer
4,951,078 A	8/1990	Okada	2004/0012866 A1	1/2004	Mann et al.
5,004,331 A	4/1991	Haseltine et al.	2004/0130806 A1	7/2004	Takahashi
5,031,976 A	7/1991	Shafer	2004/0160677 A1	8/2004	Epple et al.
5,063,586 A	11/1991	Jewell et al.	2004/0240047 A1	12/2004	Shafer et al.
5,114,238 A	5/1992	Sigler	2005/0036213 A1	2/2005	Mann et al.
5,153,898 A	10/1992	Suzuki et al.	2005/0082905 A1	4/2005	Gronau et al.
5,212,588 A	5/1993	Viswanathan et al.	2005/0179994 A1	8/2005	Webb
5,220,590 A	6/1993	Bruning et al.	2005/0190435 A1	9/2005	Shafer et al.
5,315,629 A	5/1994	Jewell et al.	2005/0225737 A1	10/2005	Weissenrieder et al.
5,353,322 A	10/1994	Bruning et al.	2006/0012885 A1	1/2006	Beder et al.
5,410,434 A	4/1995	Shafer	2006/0066962 A1	3/2006	Totzeck et al.
5,477,304 A	12/1995	Nishi	2006/0077366 A1	4/2006	Shafer
5,488,229 A	1/1996	Elliott et al.	2006/0119750 A1	6/2006	Epple et al.
5,515,207 A	5/1996	Foo	2006/0198018 A1	9/2006	Shafer
5,636,066 A	6/1997	Takahashi	2006/0221456 A1	10/2006	Shafer et al.
5,650,877 A	7/1997	Phillips, Jr. et al.	2006/0244938 A1	11/2006	Schuster
5,652,679 A	7/1997	Freeman	2006/0256447 A1	11/2006	Dodoc
5,686,728 A	11/1997	Shafer	2007/0037079 A1	2/2007	Omura
5,717,518 A	2/1998	Shafer et al.	2007/0091451 A1	4/2007	Schuster
5,729,376 A	3/1998	Hall et al.	2007/0109659 A1	5/2007	Rostalski et al.
5,734,496 A	3/1998	Beach	2007/0165198 A1	7/2007	Kneer et al.
5,802,335 A	9/1998	Sturlesi et al.			
5,805,346 A	9/1998	Tomimatsu	DE 103 32 112	1/2005	
5,805,365 A	9/1998	Sweatt	DE 102005056721	11/2006	
5,815,310 A	9/1998	Williamson	EP 0267766	5/1988	
5,861,997 A	1/1999	Takahashi	EP 0 951 054	10/1999	
5,917,879 A	6/1999	Mashima	EP 0 962 830	12/1999	
5,956,192 A	9/1999	Williamson	EP 1059550	12/2000	
5,999,310 A	12/1999	Shafer et al.	EP 1 069 448 B1	1/2001	
6,033,079 A	3/2000	Hudyma	EP 1098215 A1	10/2001	
6,097,537 A	8/2000	Takahashi et al.	EP 1 318 425 A2	6/2003	
6,169,627 B1	1/2001	Schuster	EP 1318425 B1	6/2003	
6,169,637 B1	1/2001	Tsunashima	EP 1 336 887	8/2003	
6,172,825 B1	1/2001	Takahashi	EP 1 336 887 A1	8/2003	
6,188,513 B1	2/2001	Hudyma et al.	JP 5-175098	7/1993	
6,195,213 B1	2/2001	Omura et al.	JP 6-188169	7/1994	
6,213,610 B1	4/2001	Takahashi et al.	JP 8-166542	6/1995	
6,259,510 B1	7/2001	Suzuki	JP 8-330220	12/1996	
6,262,845 B1	7/2001	Sweatt	JP 9-148241	6/1997	
6,285,737 B1	9/2001	Sweatt et al.	JP 10-163099	6/1998	
6,353,470 B1	3/2002	Dinger	JP 10-214783	8/1998	
6,426,506 B1	7/2002	Hudyma	JP 10-284408	10/1998	
6,473,243 B1	10/2002	Omura	JP 10-303114	11/1998	
6,600,608 B1	7/2003	Shafer et al.	JP 2000-505958	5/2000	
6,631,036 B2	10/2003	Schuster	JP 2001-228401	8/2001	
6,636,350 B2	10/2003	Shafer et al.	JP 3246615	11/2001	
6,750,948 B2	6/2004	Omura	JP 2002-208551	7/2002	
6,757,051 B2	6/2004	Takahashi et al.	JP 2002208551 A	7/2002	
6,822,727 B2	11/2004	Shima	JP 2002372668	12/2002	
6,829,099 B2	12/2004	Kato et al.	JP 2003114387	4/2003	
6,842,298 B1	1/2005	Shafer et al.	JP 2003-307680	10/2003	
6,873,476 B2	3/2005	Shafer et al.	JP 2004-333761	11/2004	
6,912,042 B2	6/2005	Shafer	JP 2004317534	11/2004	
6,995,886 B2	2/2006	Hendriks	JP 2005-003982 A	1/2005	
6,995,918 B2	2/2006	Terasawa	SU 124665	3/1959	

US 7,385,756 B2

Page 3

WO WO 92/05462 A2 4/1992
WO WO94/06047 3/1994
WO WO 94/06047 A1 3/1994
WO WO 98/28665 7/1998
WO WO 99/26097 5/1999
WO WO 99/42905 8/1999
WO WO 99/57596 11/1999
WO WO 01/04682 A1 1/2001
WO WO 01/55767 A2 8/2001
WO WO 01/55767 A3 8/2001
WO WO 2003/088330 A1 10/2003
WO WO 2004/010200 1/2004
WO WO 2004/019128 3/2004
WO WO 2004/107011 A1 12/2004
WO WO 2005/015316 2/2005
WO WO 2005/059055 7/2005
WO WO 2005/098506 10/2005
WO WO 2005/098504 10/2005
WO WO 2005/098505 10/2005
WO WO 2006/005547 1/2006
WO WO 2007/025643 3/2007
WO WO 2007/086220 8/2007

OTHER PUBLICATIONS

Tomoyuki Matsuyama et al., Nikon Projection Lens Update, Proceedings of SPIE, 2004, vol. 5377, No. 65.

Donald DeJager, Camera viewfinder using tilted concave mirror erecting elements, International Lens Design Conference (OSA), SPIE, 1980, pp. 292-298, vol. 237.
U.S. Appl. No. 60/511,673, filed Oct. 17, 2003.
U.S. Appl. No. 60/530,623, filed Dec. 19, 2003.
"Rapid Communication", Applied Optics, vol. 23, No. 13, Sep. 1, 1984.
"Expansion hysteresis upon thermal cycling of Zerodur", Jacobs et al., Applied Optics, vol. 23, No. 17, Sep. 1, 1984.
"Thermal expansion and length stability of Zerodur in dependence on temperature and time", Lindig et al., Applied Optics, vol. 24, No. 20, Oct. 15, 1985.
M. Switkes et al., Resolution Enhancement of 157-nm Lithography by Liquid Immersion, Proc. SPIE vol. 4691, Optical Microlithography XV, pp. 459-465, Jul. 2002.
Tomoyuki Matsuyama et al., "Microlithographic Lens for DUV Scanner," SPIE vol. 4832, Dec. 2003, Conference Jun. 3-7, 2002, pp. 170-174.
Tomoyuki, Matsuyama et al., "High NA and Low Residual Aberration Projection Lens for DUV Scanner," PSIE, vol. 4691 2002, pp. 687-695.
Ulrich, W. et al., "Trends in Optical Design of Projection Lenses for UV-and EUV-Lithography," Proc. Of SPIE, vol. 4146 (2000).
Glatzel, E., "New Lenses for Microlithography," SPIE vol. 237 (1980), pp. 310-320.

* cited by examiner

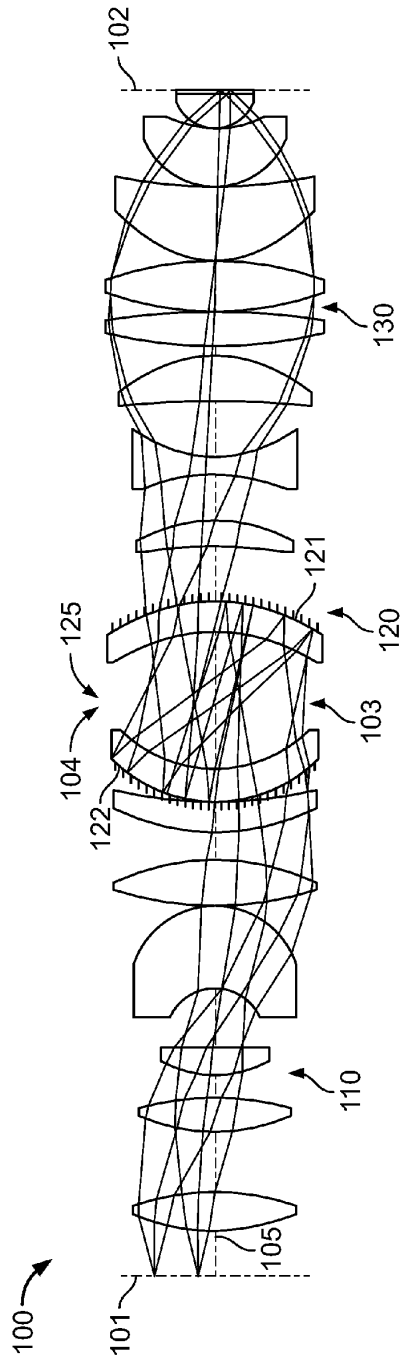

FIG. 1

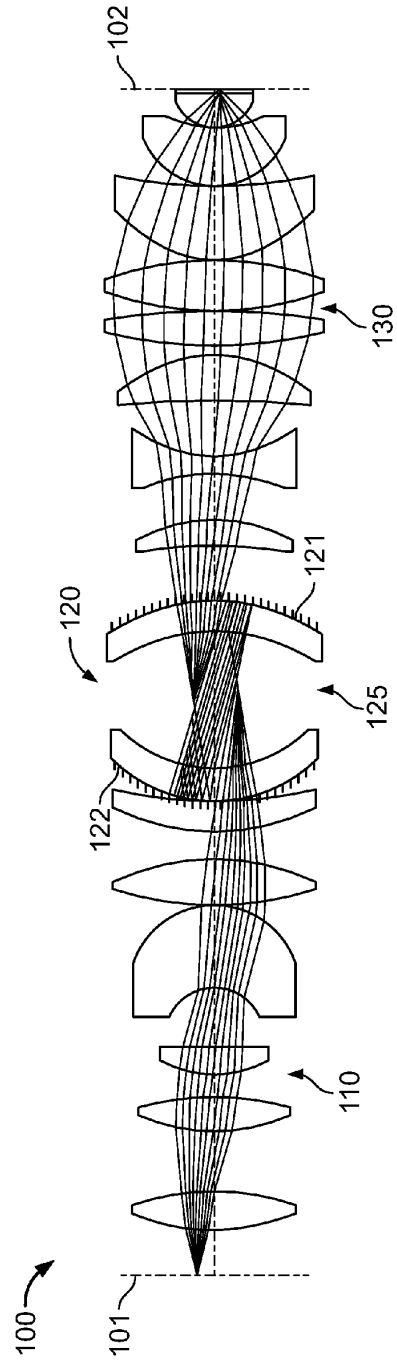

FIG. 2

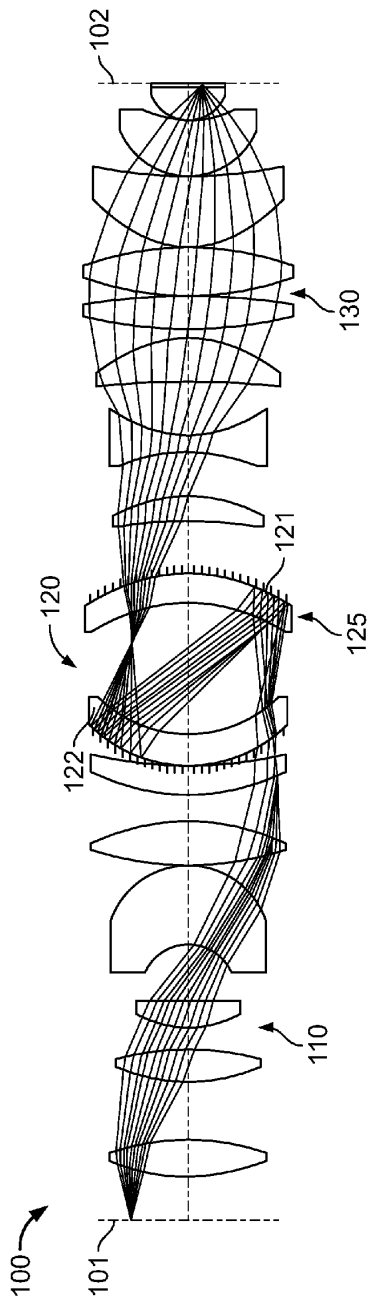

FIG. 3

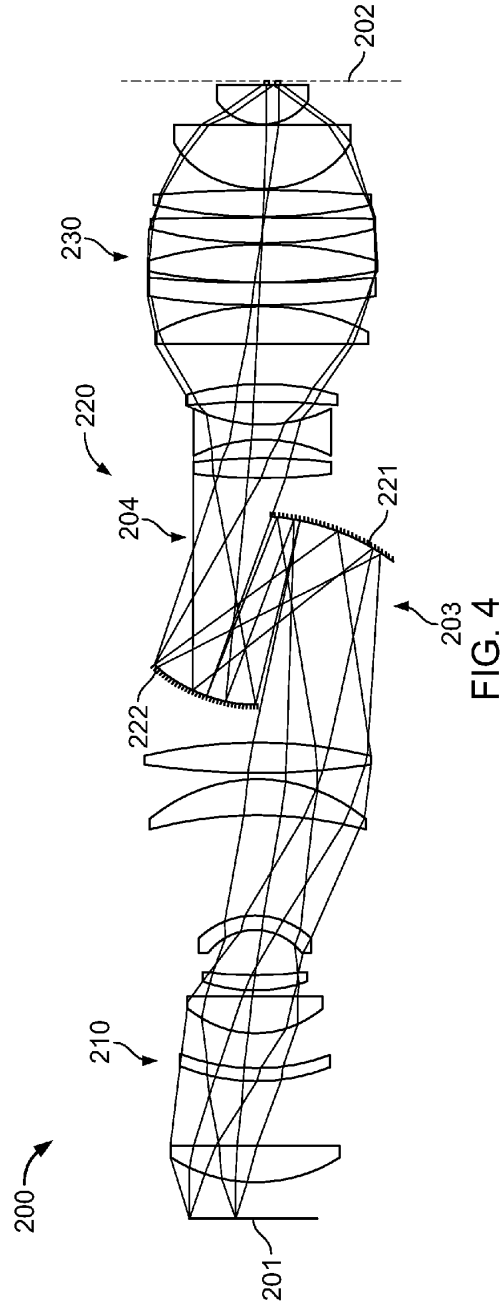

FIG. 4

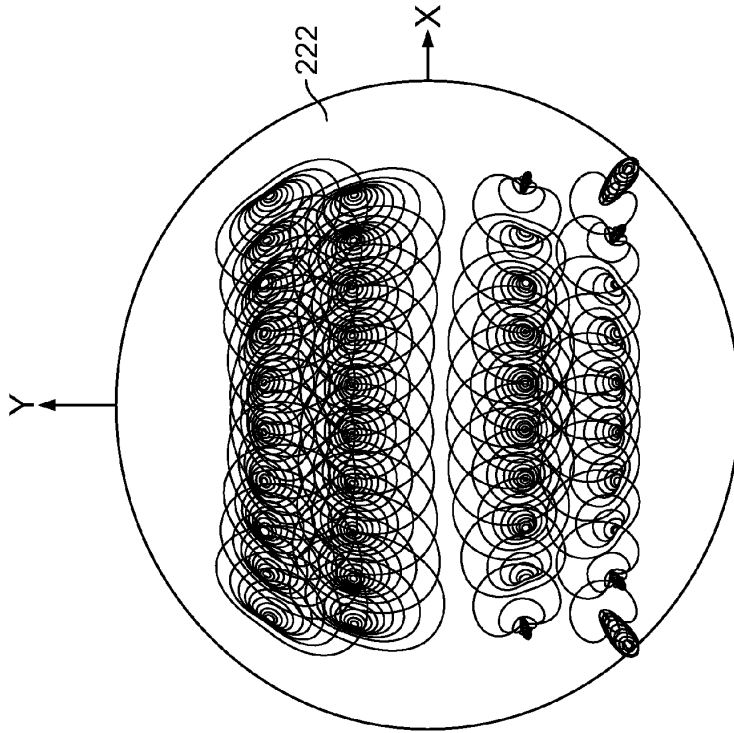

FIG. 6

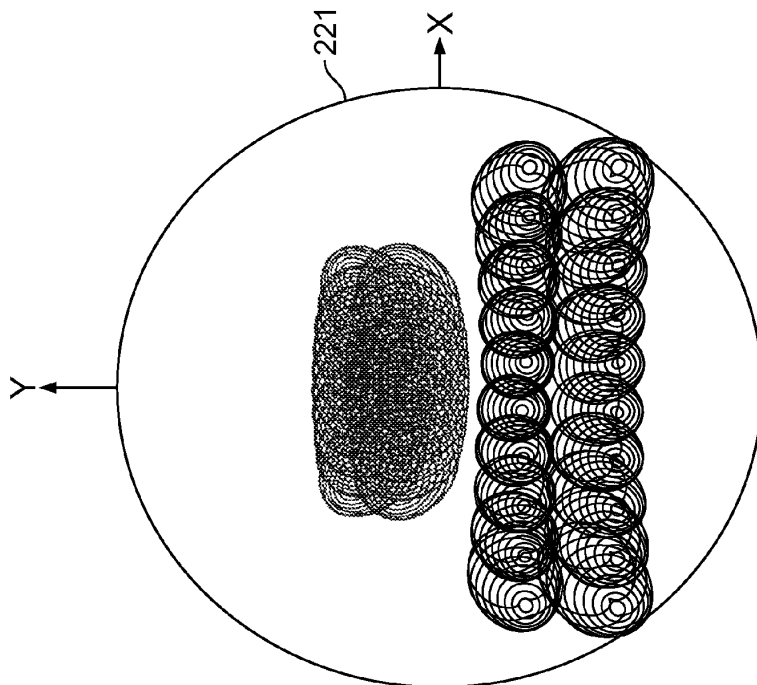

FIG. 5

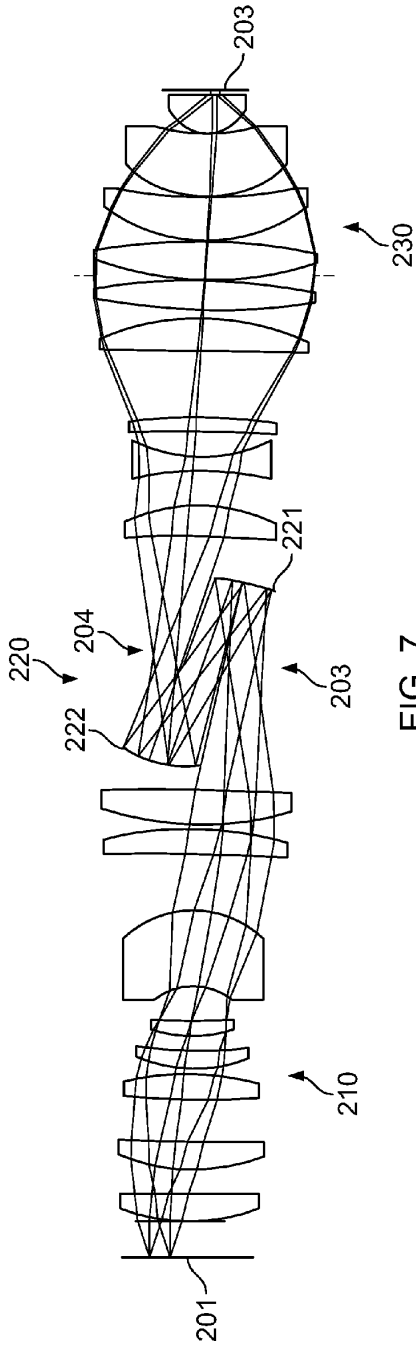

FIG. 7

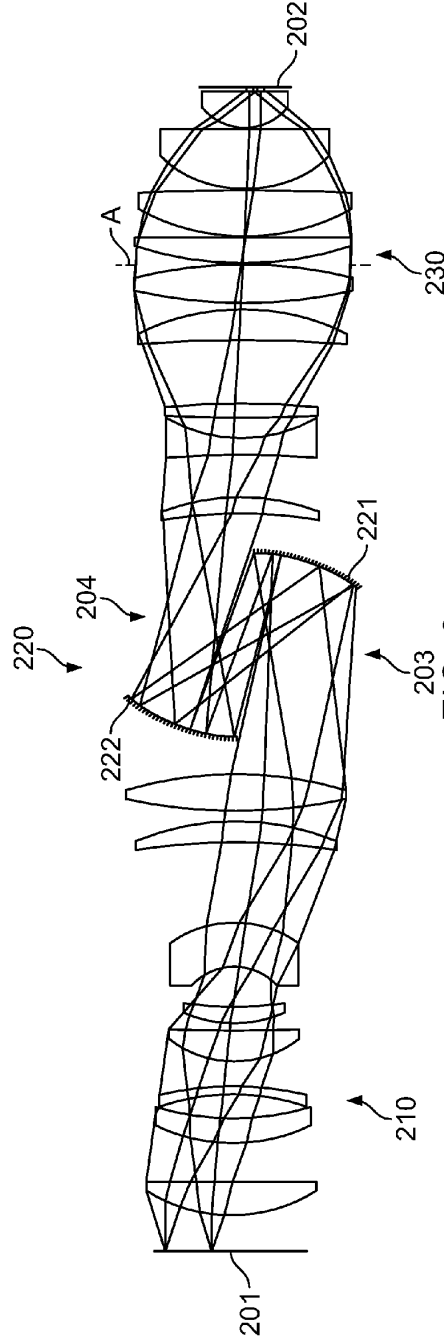

FIG. 8

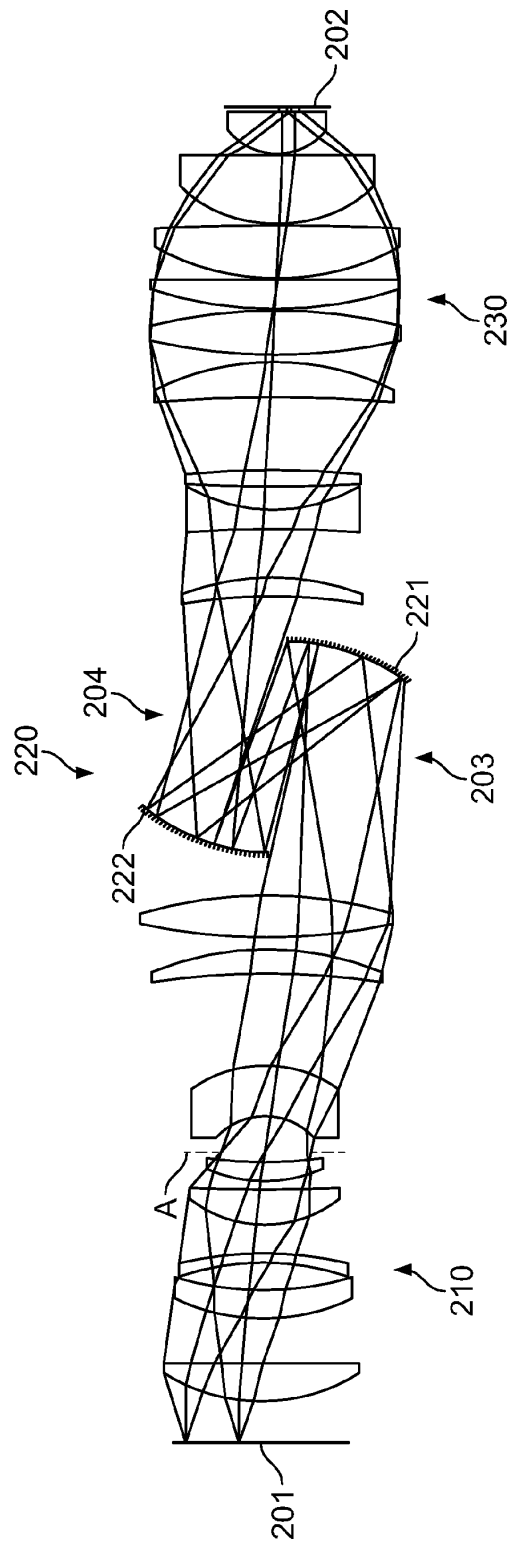

FIG. 9

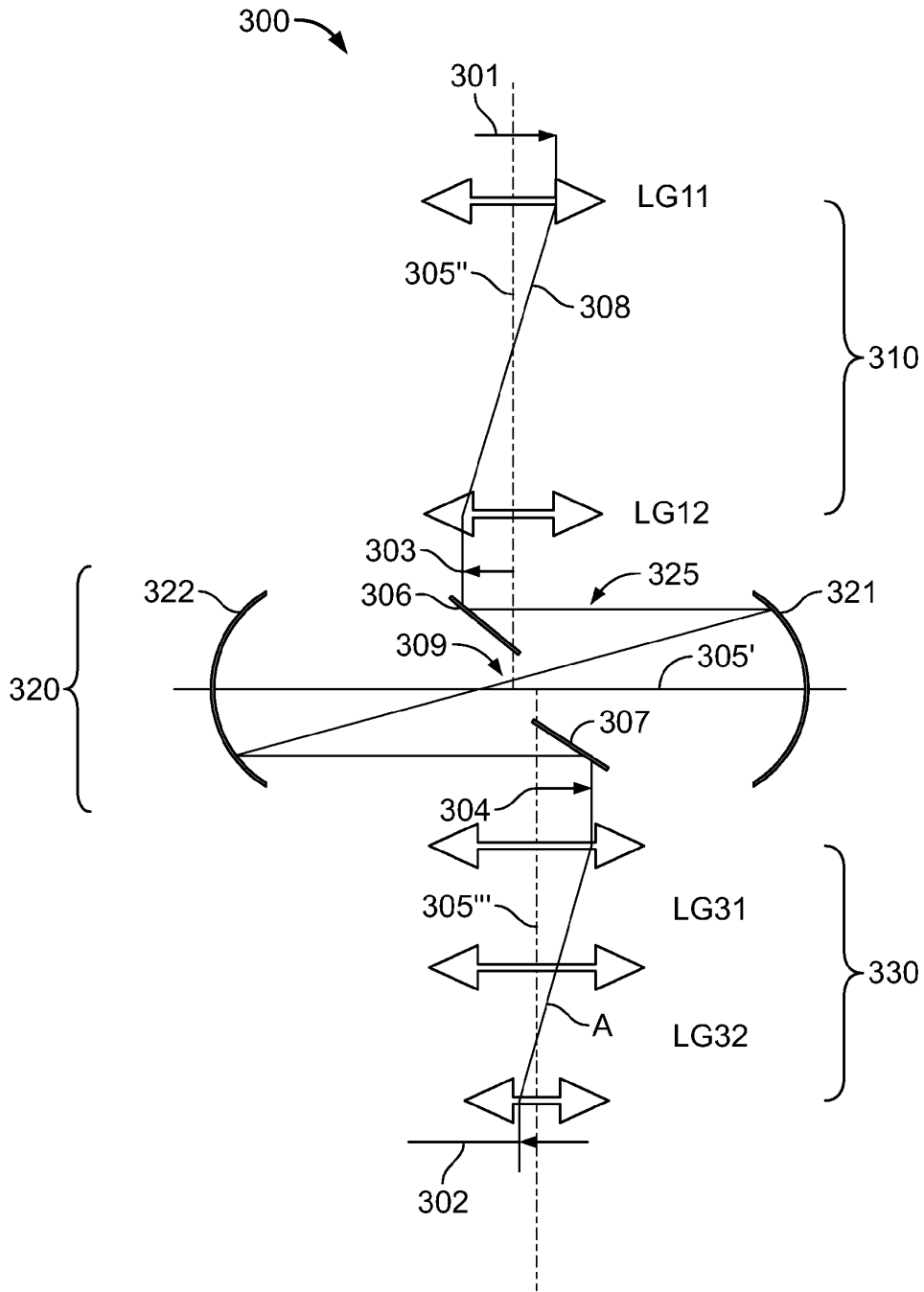

FIG. 10

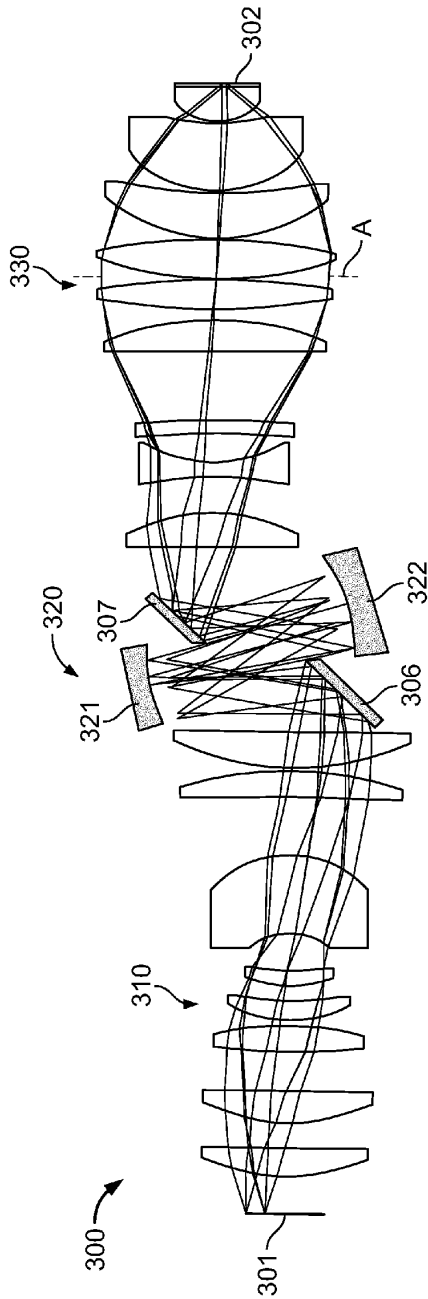

FIG. 11

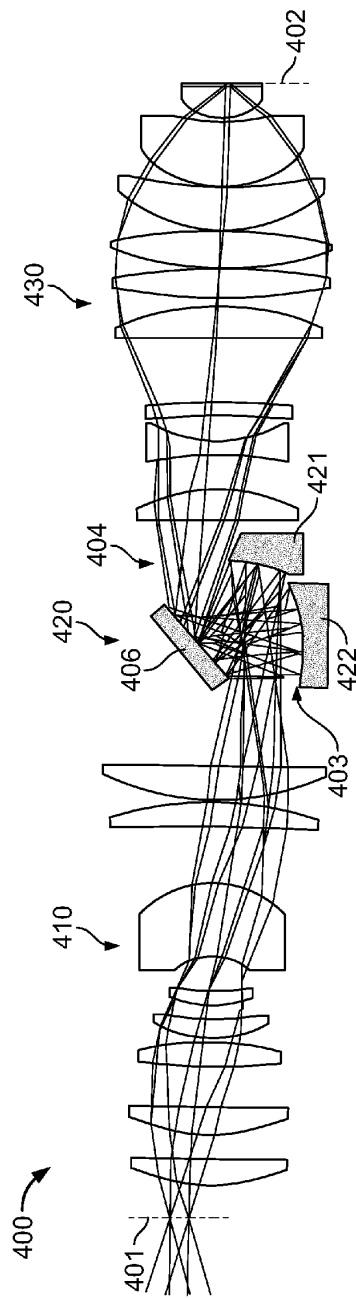

FIG. 13

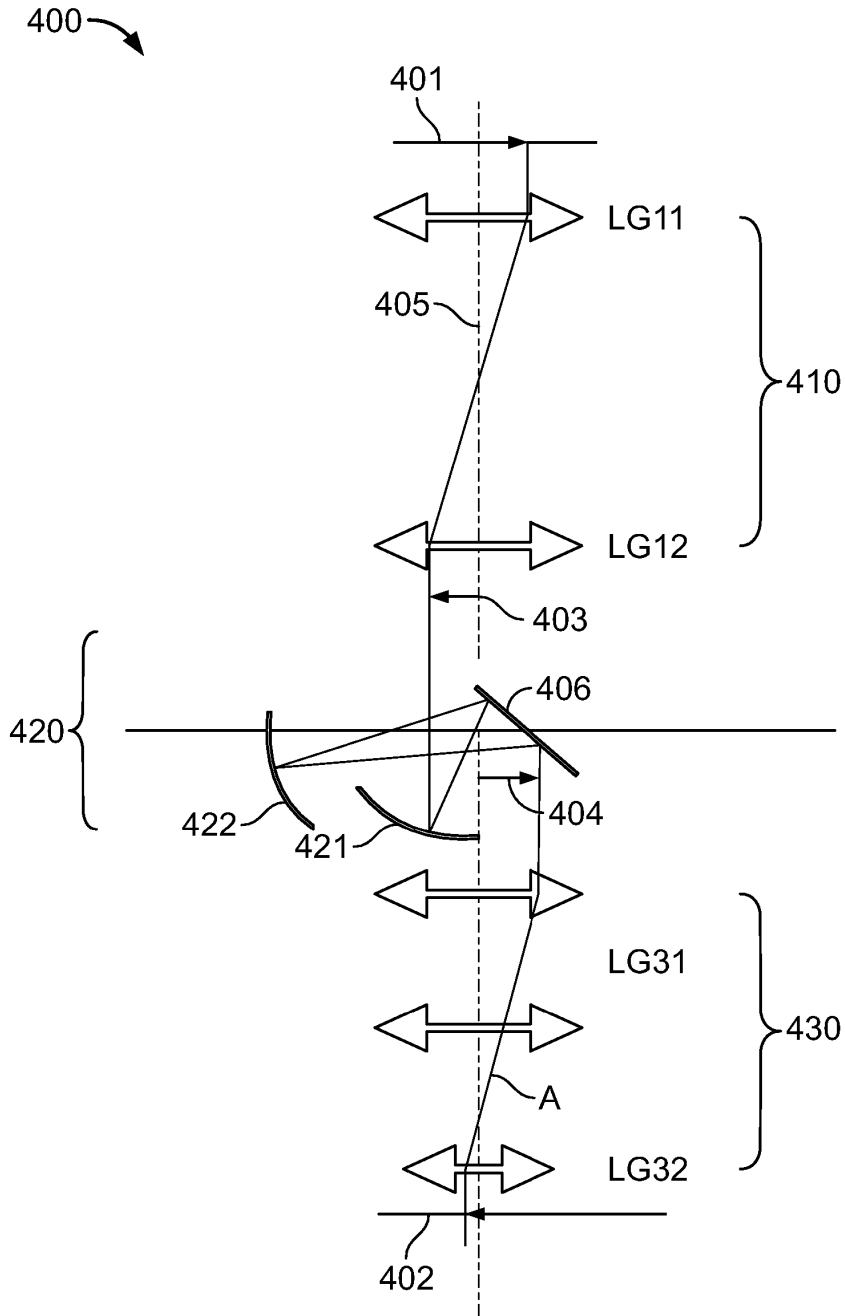

FIG. 12

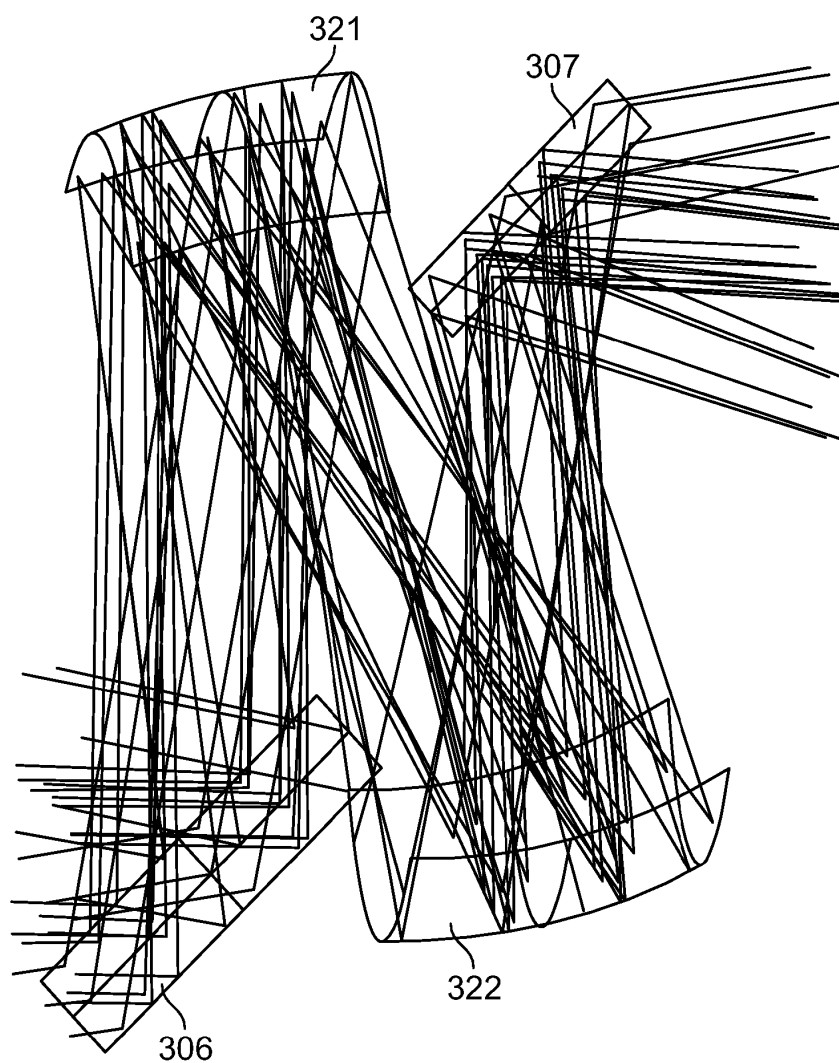

FIG. 14

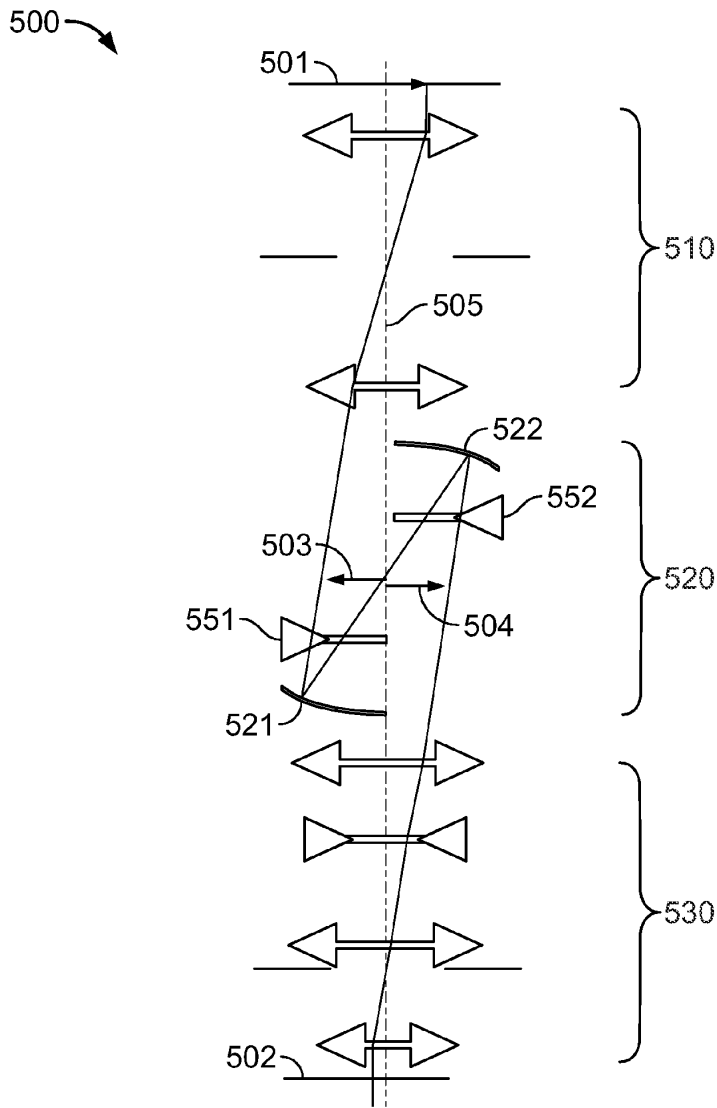

FIG. 15

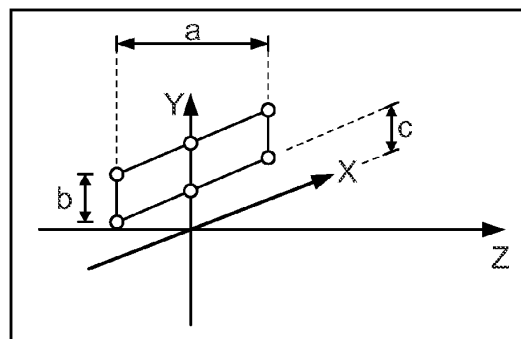

FIG. 15A

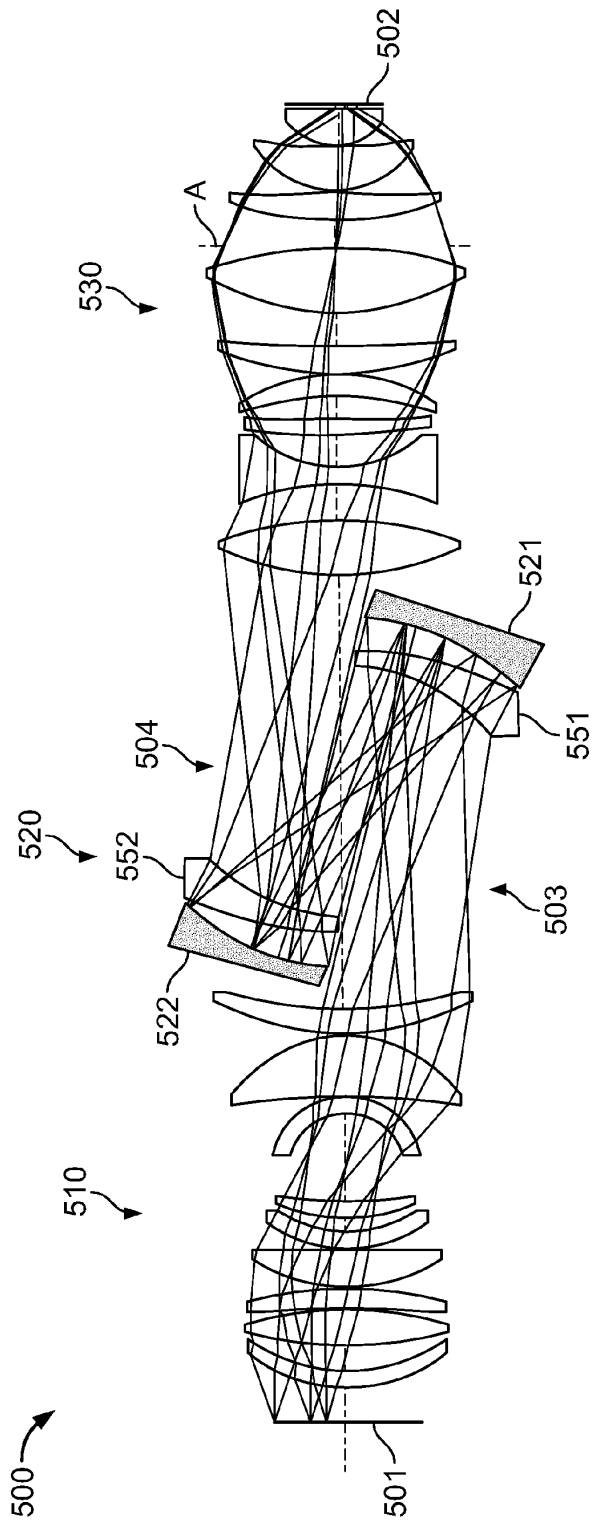

FIG. 16

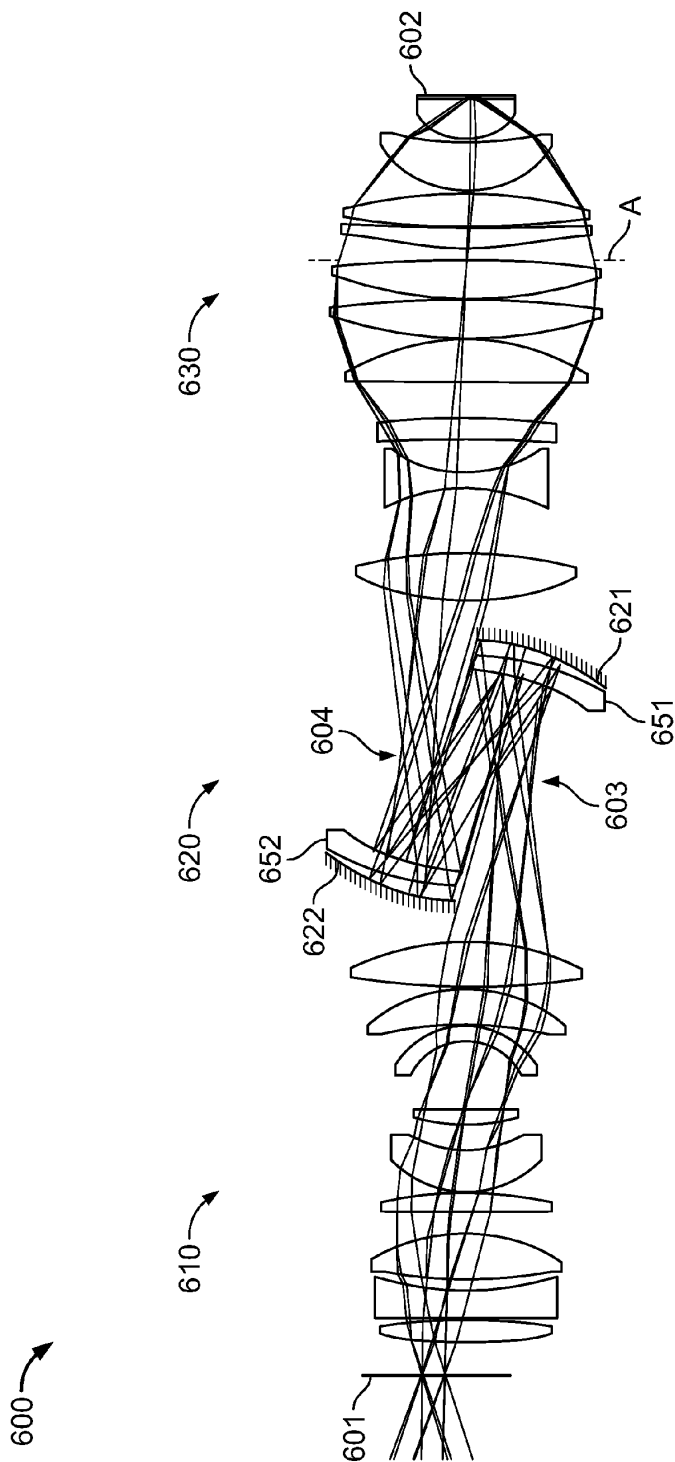

FIG. 17

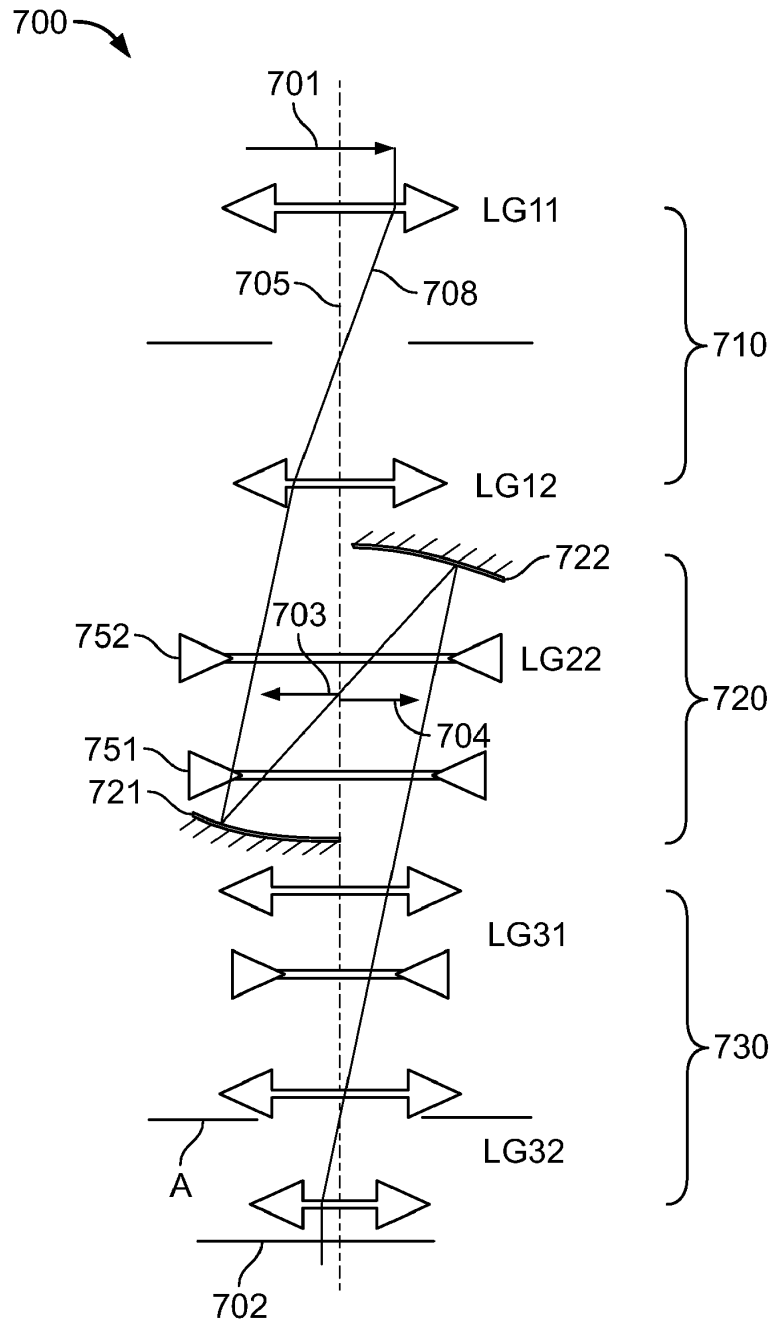

FIG. 18

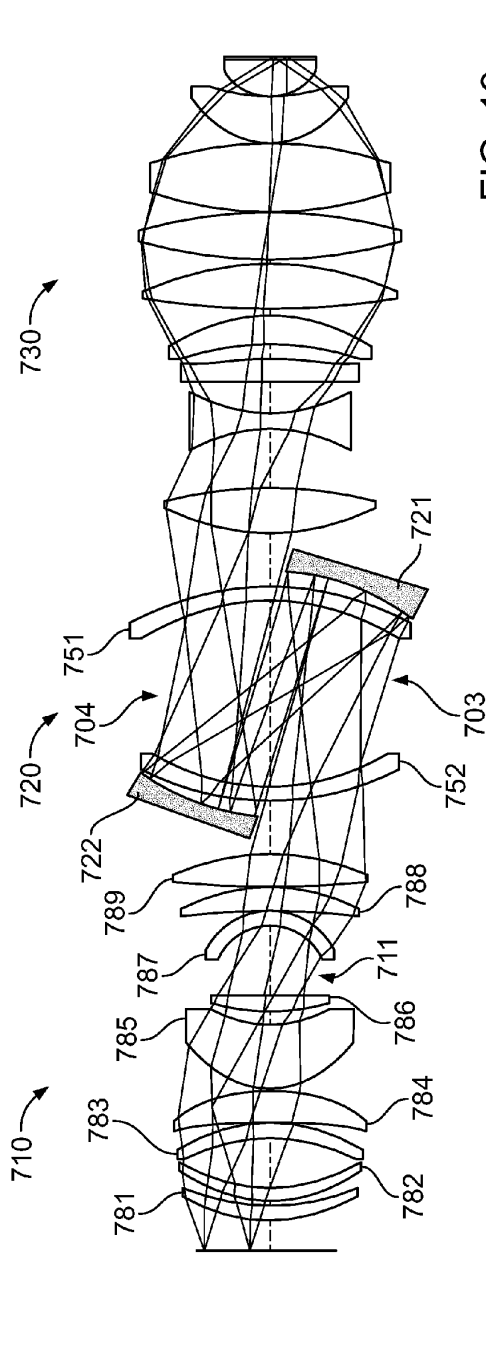

FIG. 19

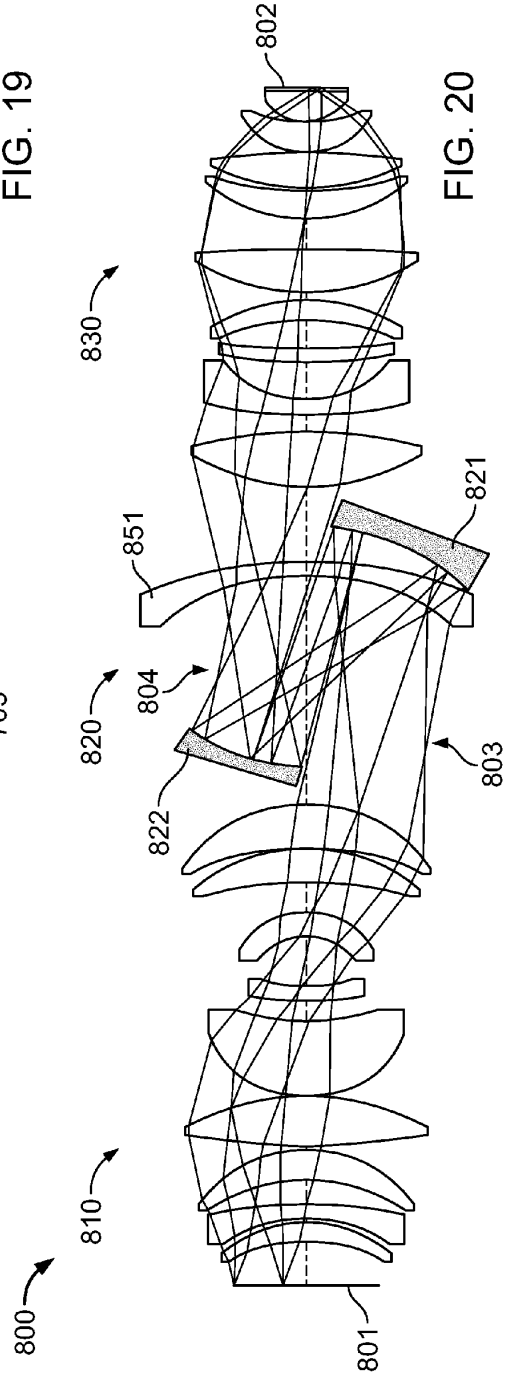

FIG. 20

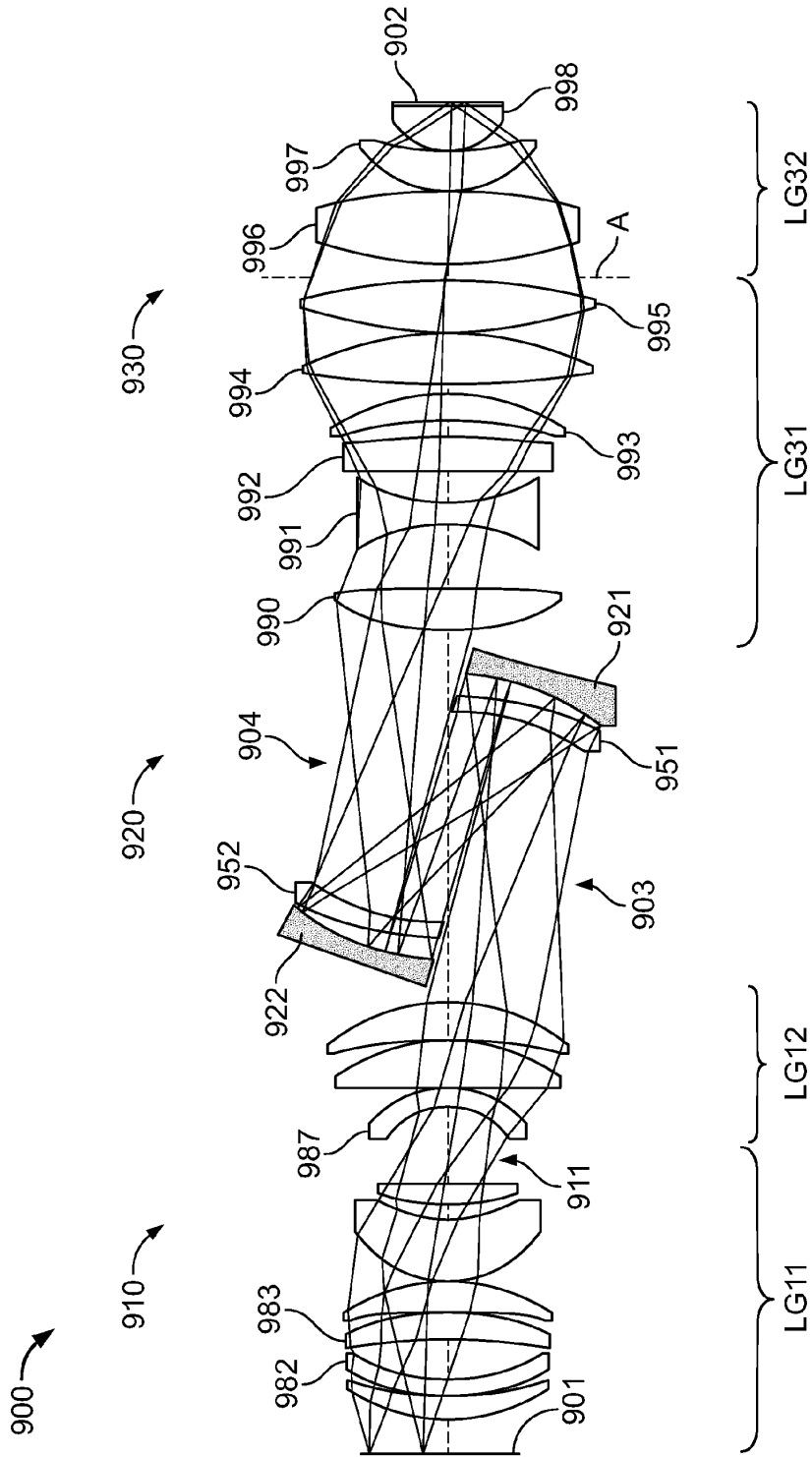

FIG. 21

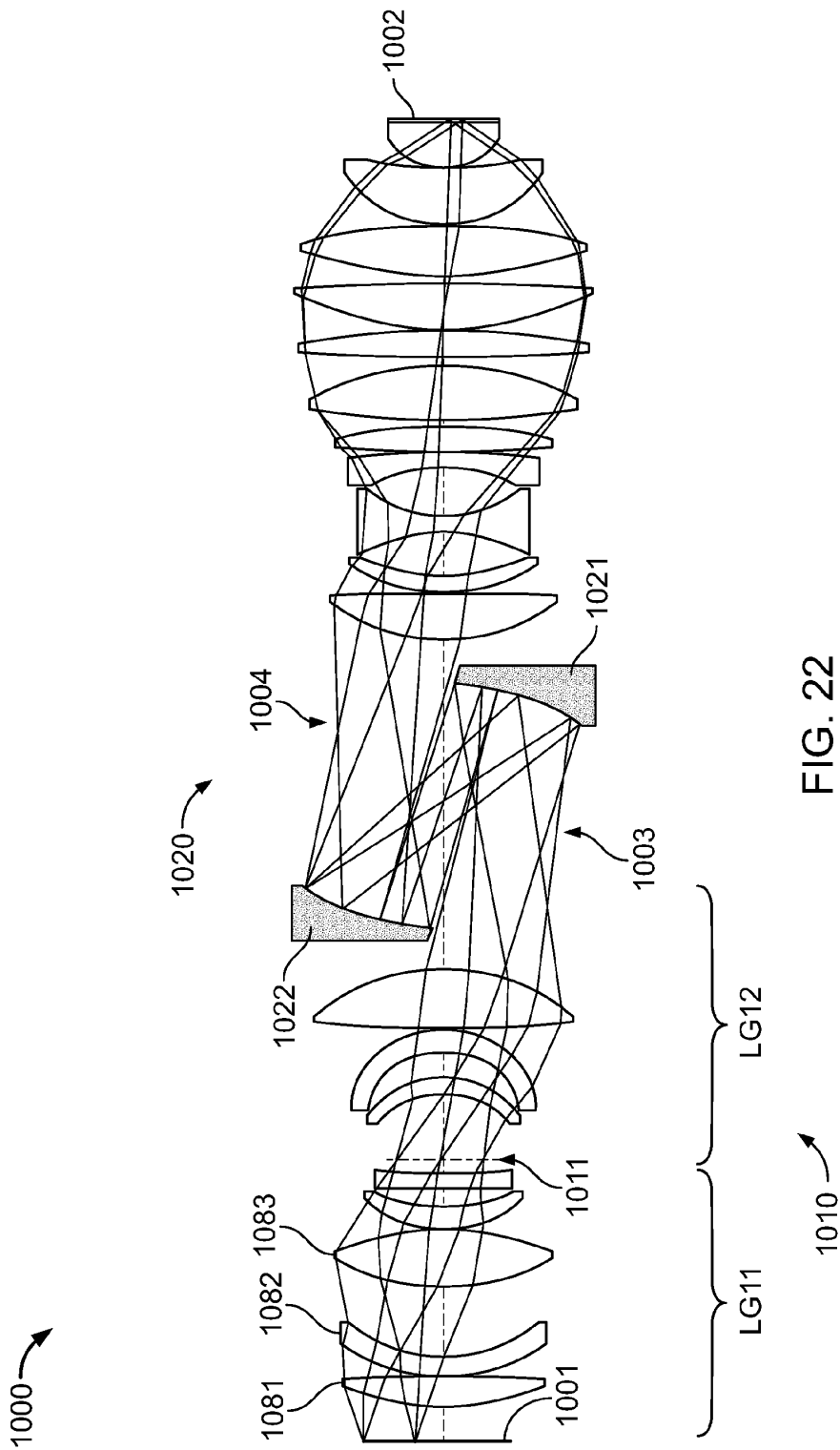

FIG. 22

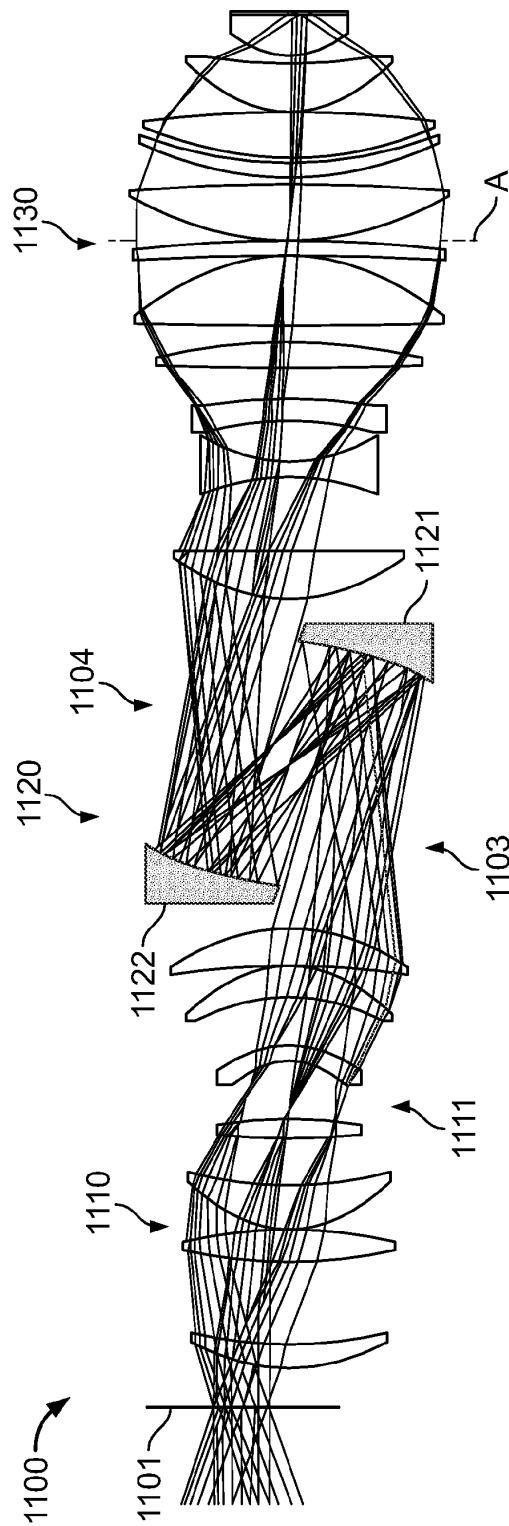

FIG. 23

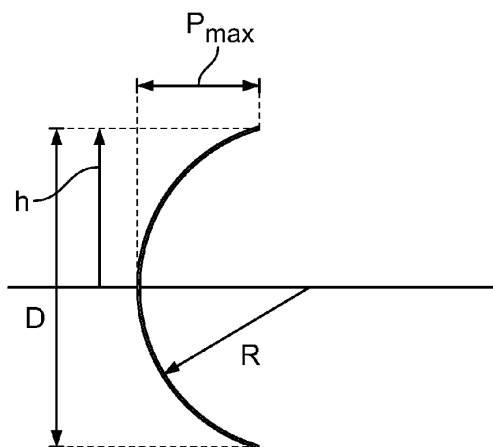

FIG. 24

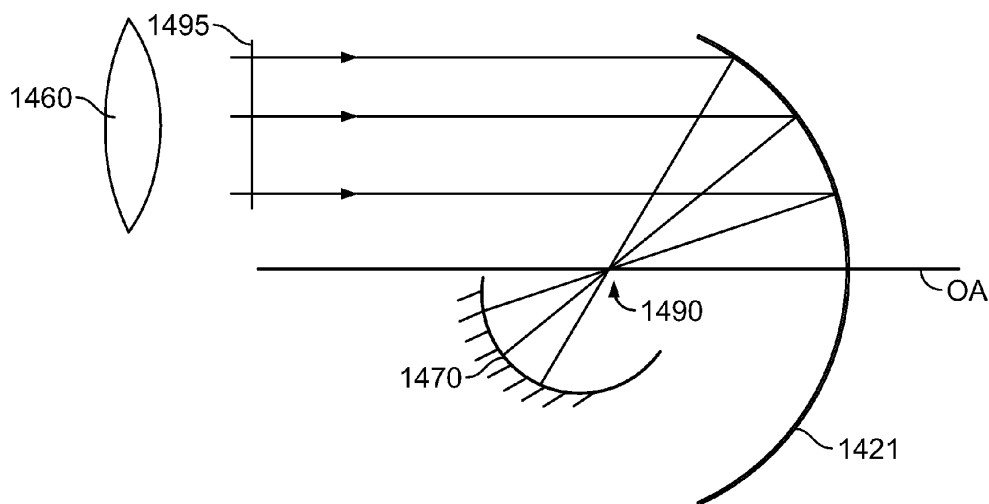

FIG. 29

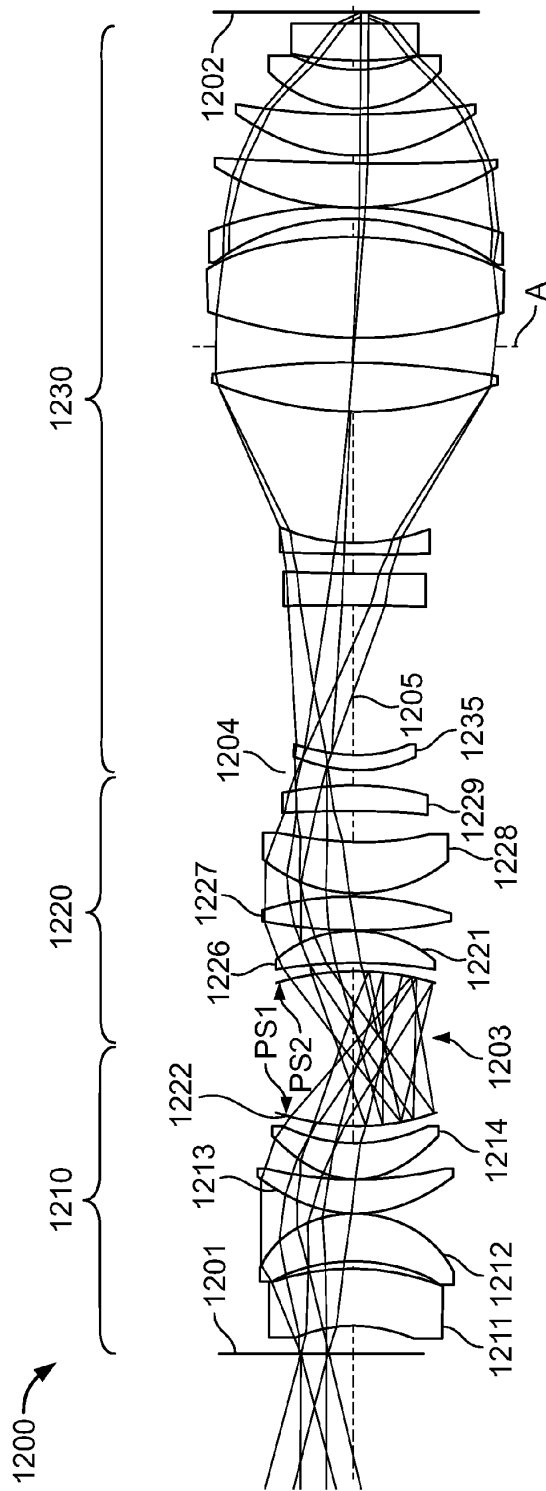

FIG. 25

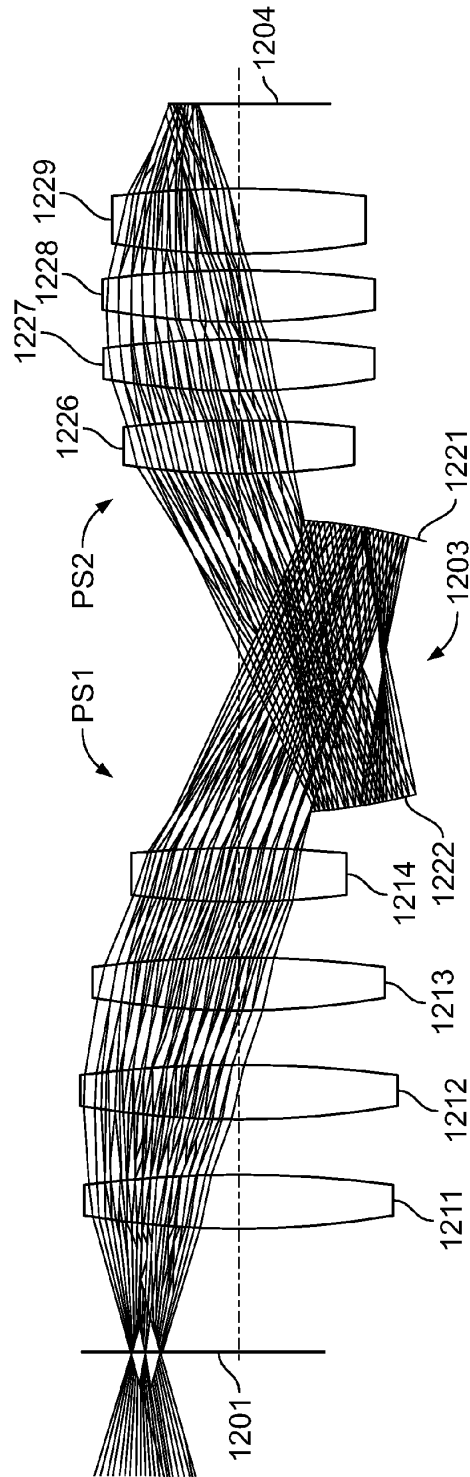

FIG. 26

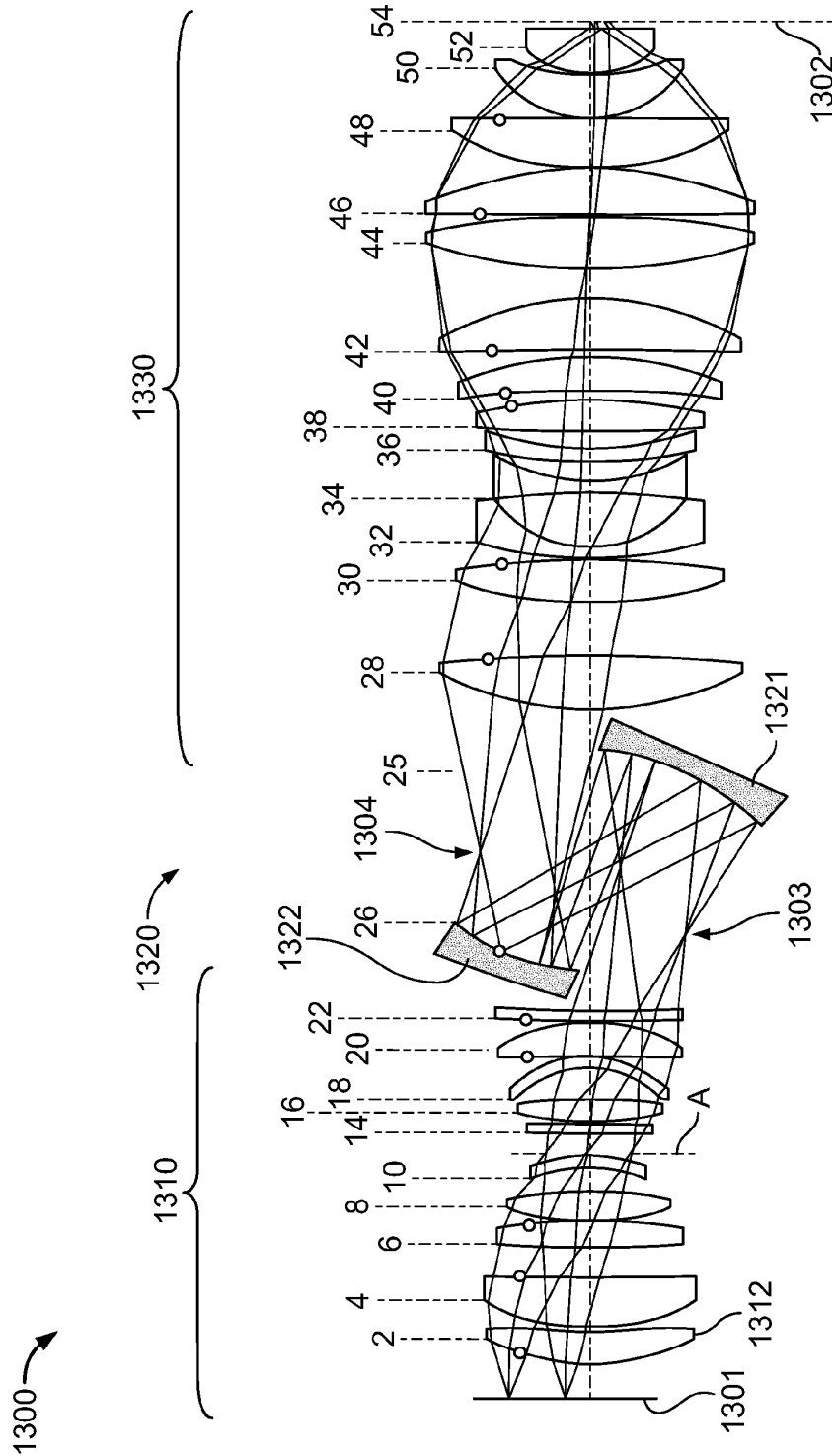

FIG. 27

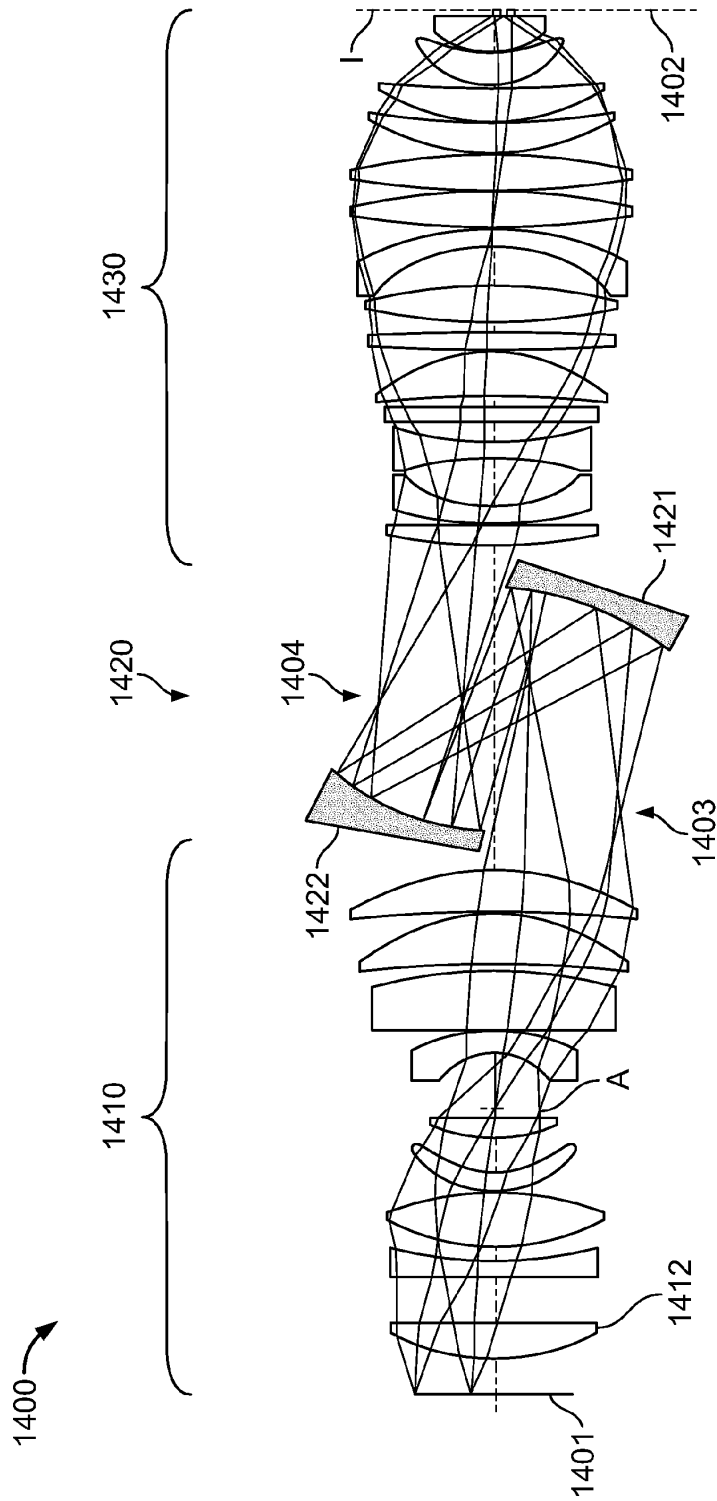

FIG. 28

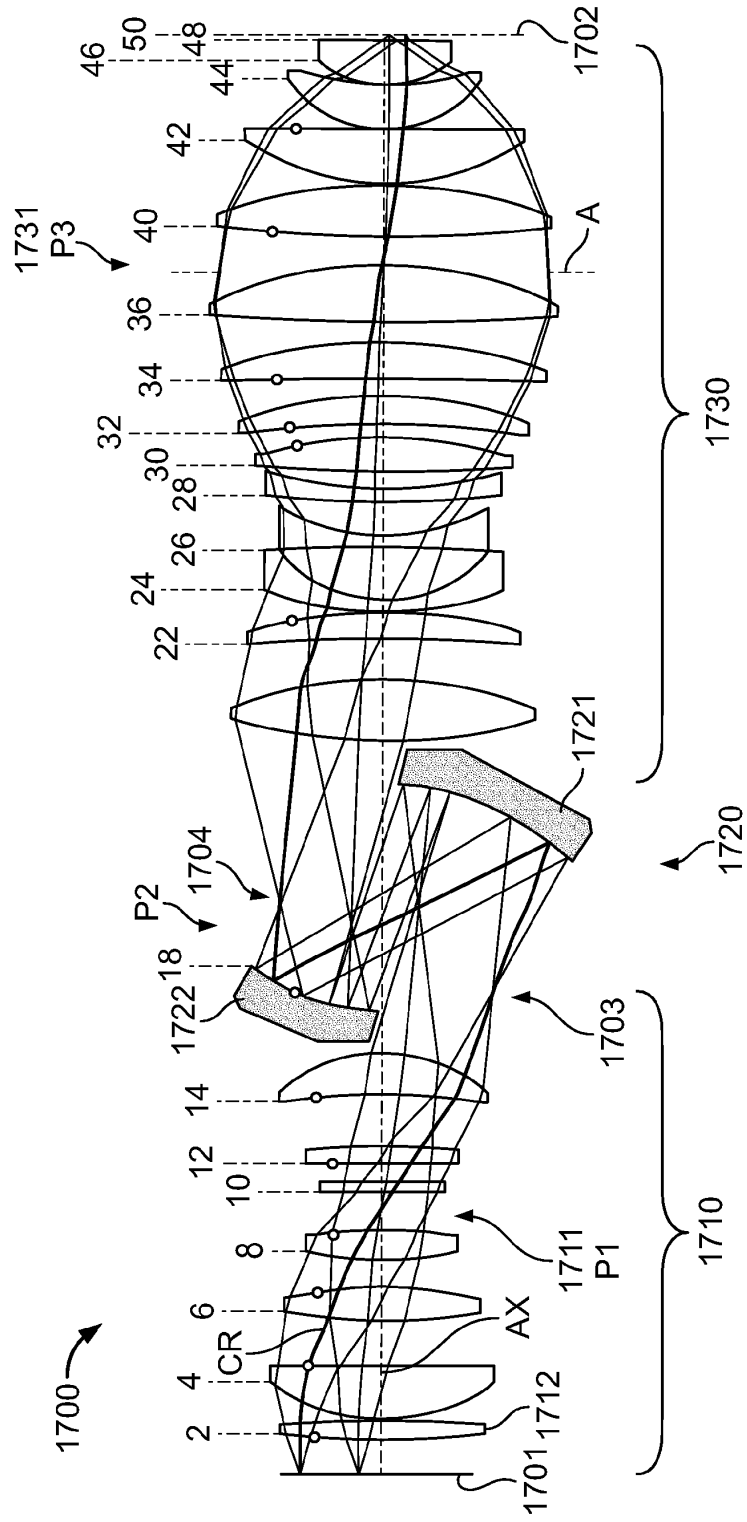

FIG. 32

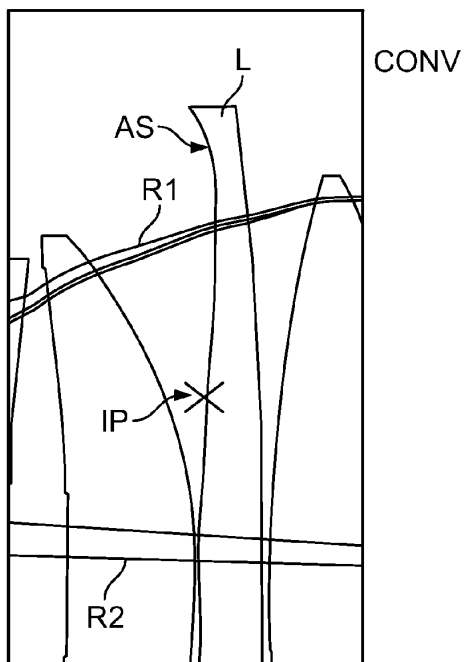

FIG. 33A

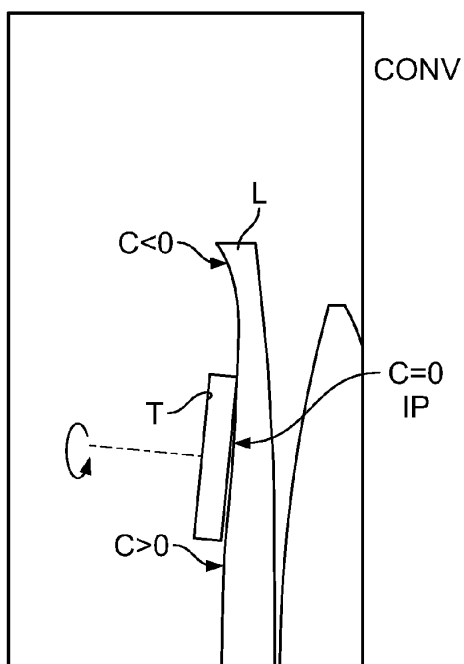

FIG. 33B

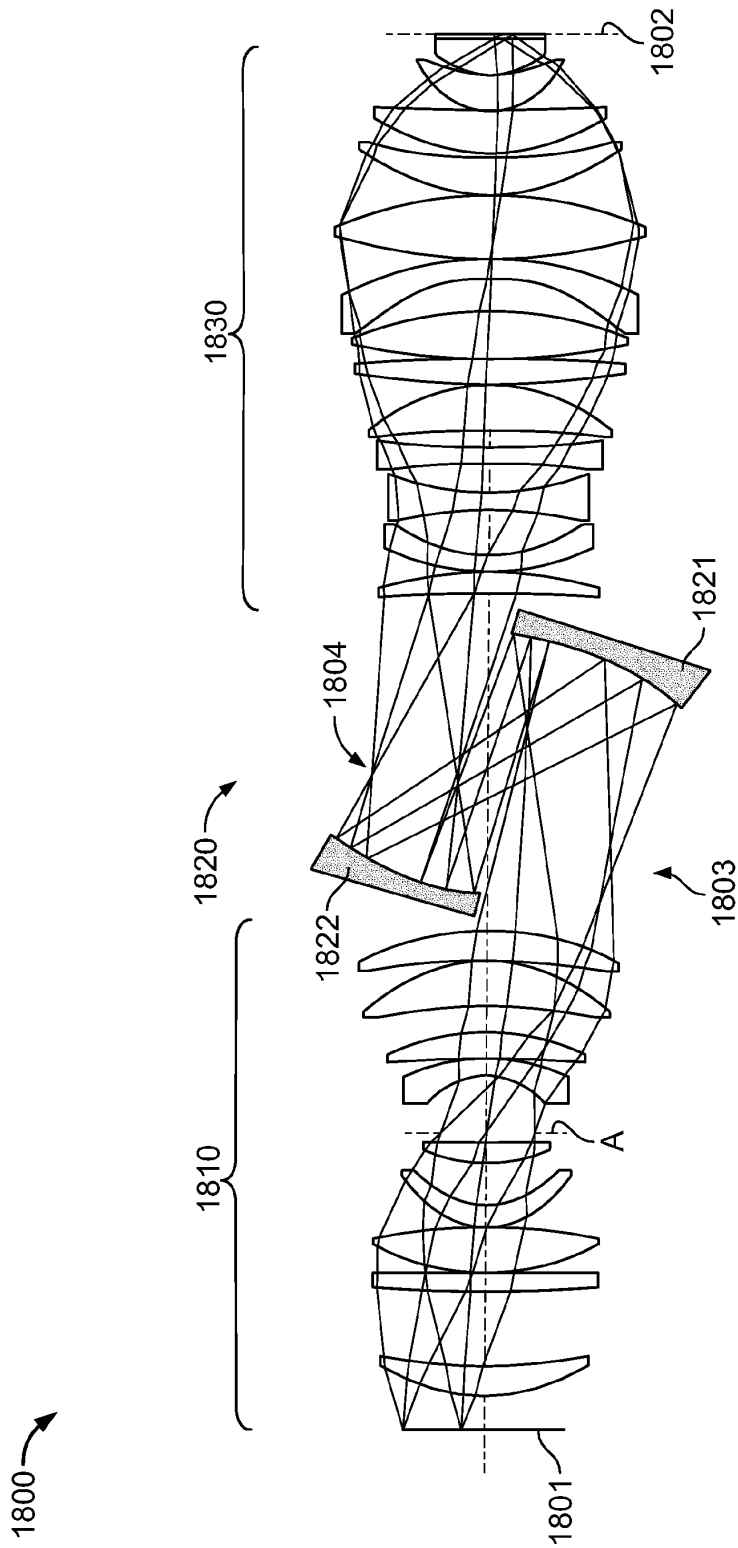

FIG. 34

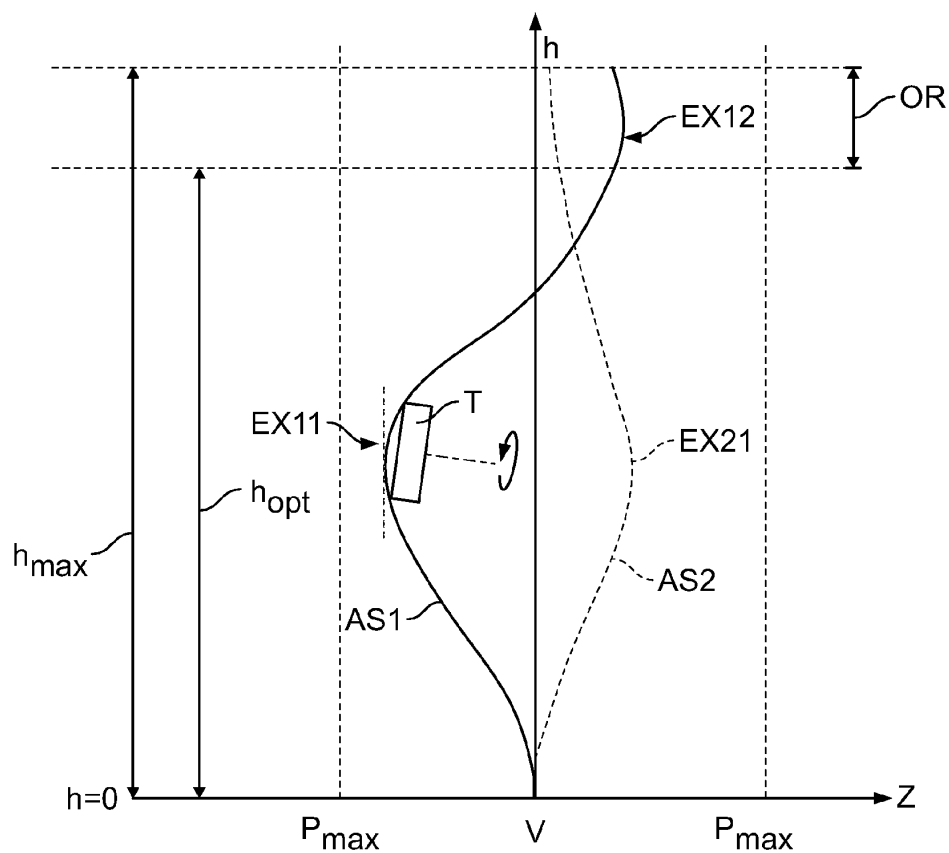

FIG. 35

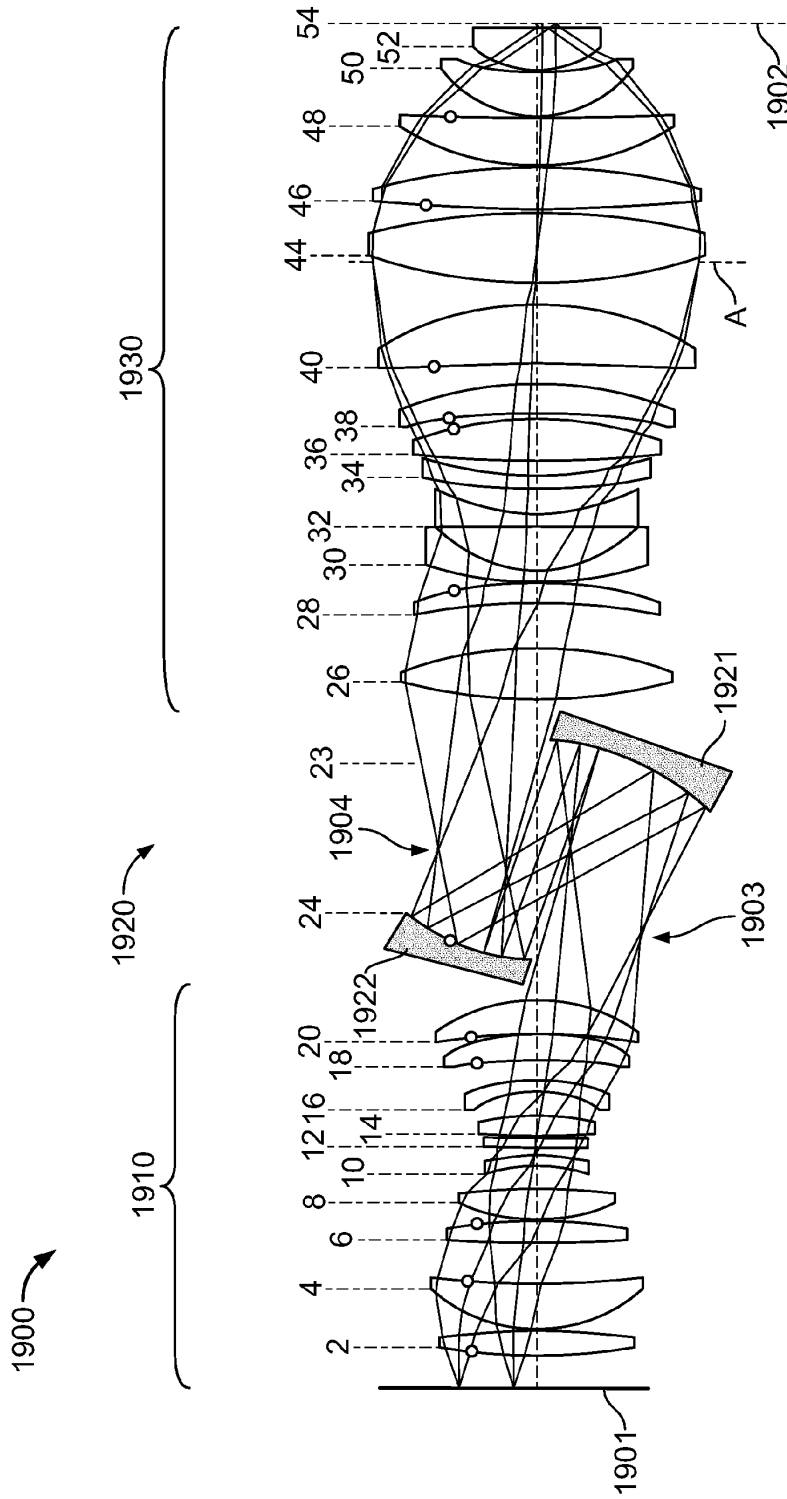

FIG. 36

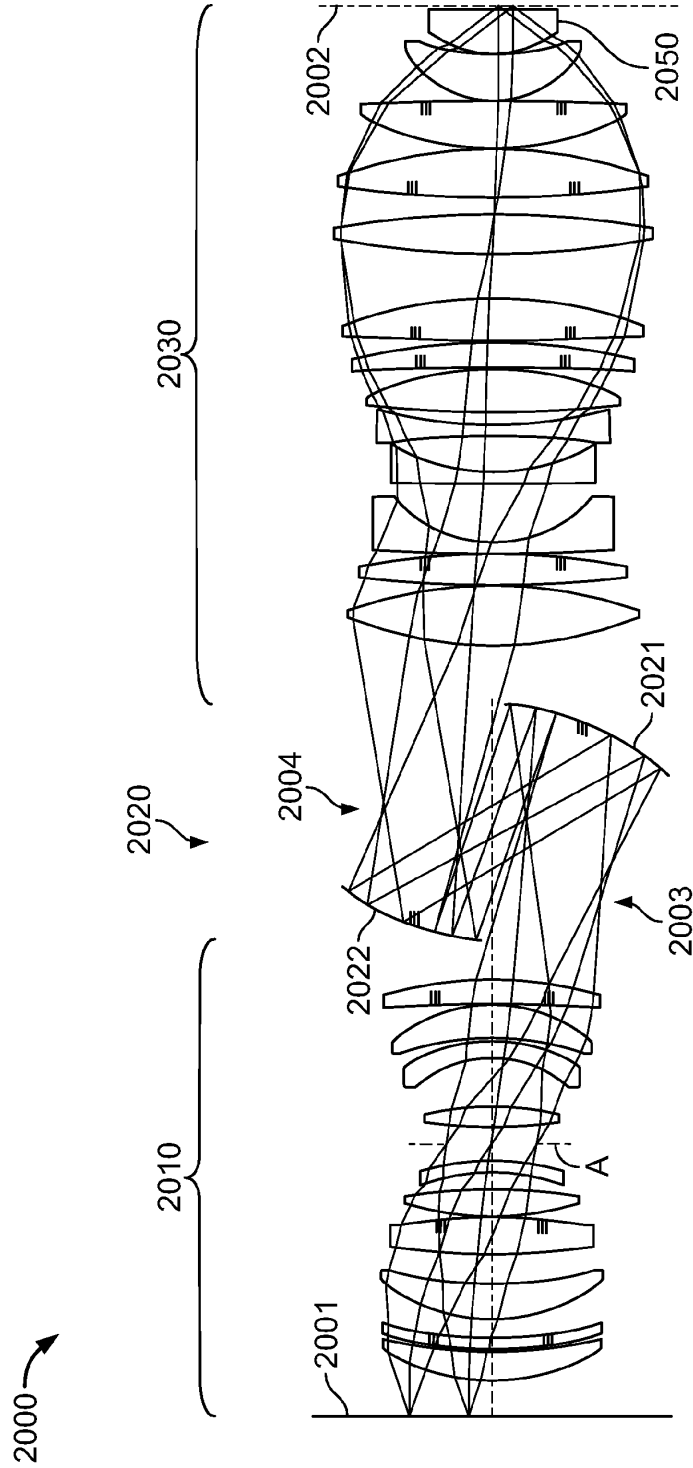

FIG. 37

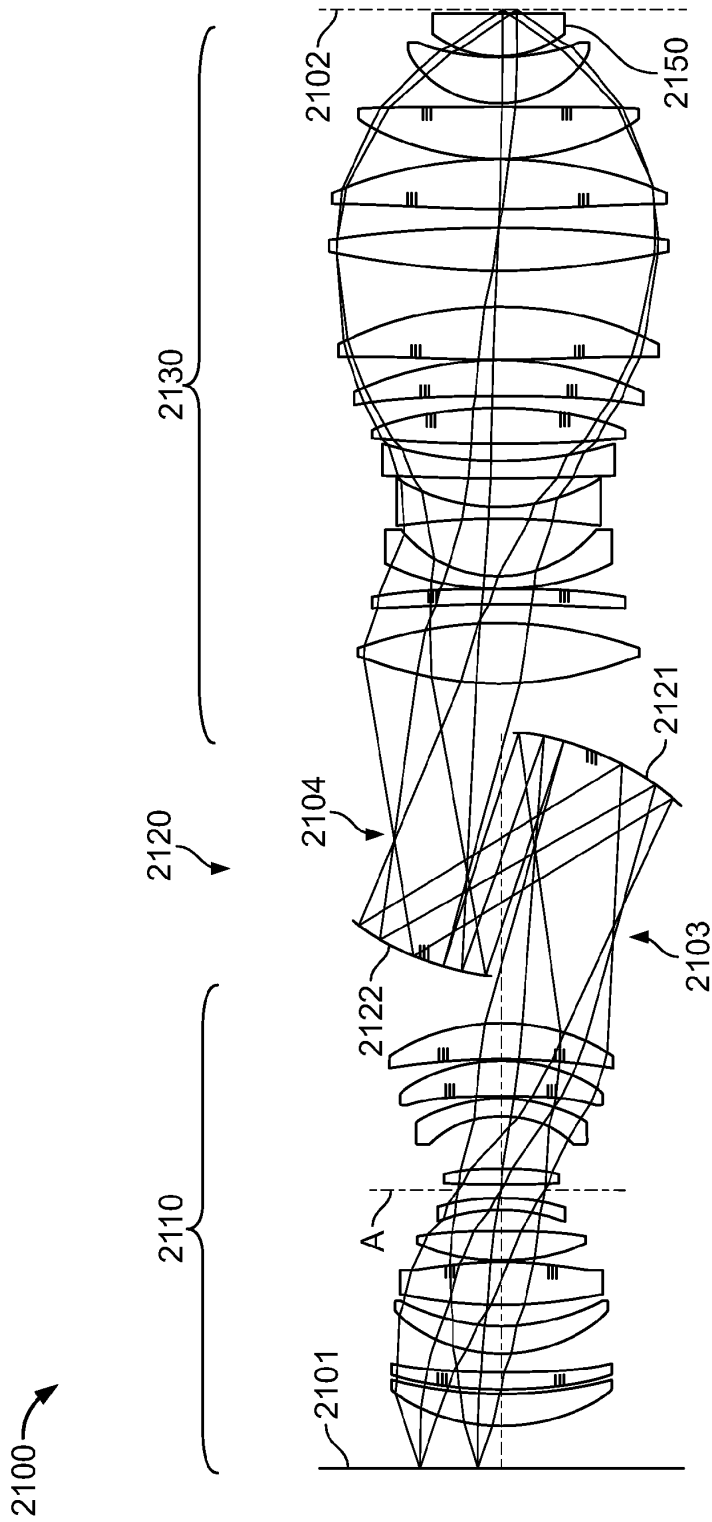

FIG. 38

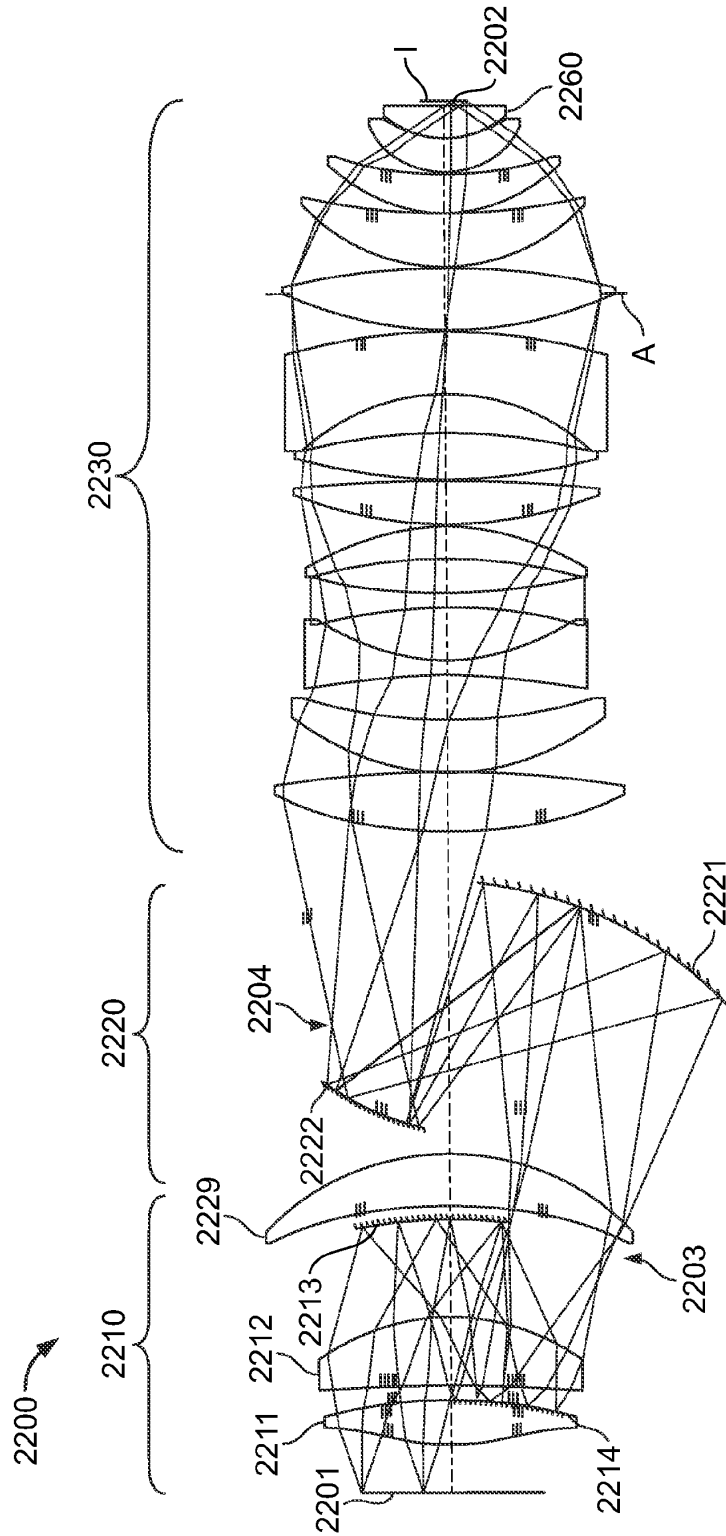

FIG. 39

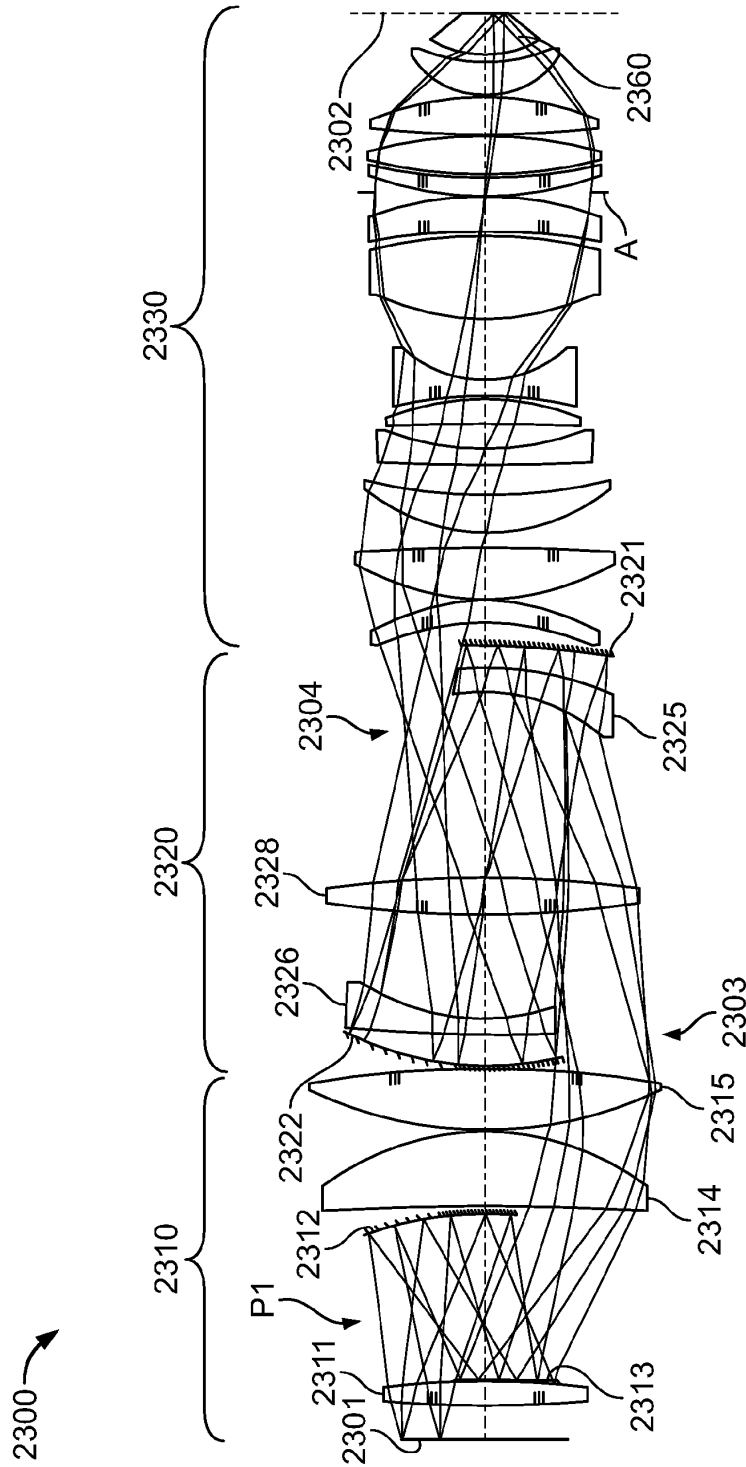

FIG. 40

CATADIOPTRIC PROJECTION OBJECTIVE

The present application claims priority benefit to U.S. Provisional 60/536,248 filed Jan. 14, 2004; U.S. Provisional 60/587,504 filed Jul. 14, 2004; U.S. Provisional 60/617,674 filed Oct. 13, 2004; and U.S. Provisional 60/612,823 filed Sep. 24, 2004. The disclosures of all of these Provisional applications are incorporated into this application by reference.

BACKGROUND OF THE INVENTION**1. Field of the Invention**

The invention relates to a catadioptric projection objective for imaging a pattern arranged in an object plane onto an image plane.

2. Description of the Related Art

Projection objectives of that type are employed on projection exposure systems, in particular wafer scanners or wafer steppers, used for fabricating semiconductor devices and other types of microdevices and serve to project patterns on photomasks or reticles, hereinafter referred to generically as "masks" or "reticles," onto an object having a photosensitive coating with ultrahigh resolution on a reduced scale.

In order to create even finer structures, it is sought to both increase the image-end numerical aperture (NA) of the projection objective to be involved and employ shorter wavelengths, preferably ultraviolet light with wavelengths less than about 260 nm.

However, there are very few materials, in particular, synthetic quartz glass and crystalline fluorides, that are sufficiently transparent in that wavelength region available for fabricating the optical elements required. Since the Abbe numbers of those materials that are available lie rather close to one another, it is difficult to provide purely refractive systems that are sufficiently well color-corrected (corrected for chromatic aberrations).

In view of the aforementioned problems, catadioptric systems that combine refracting and reflecting elements, i.e., in particular, lenses and mirrors, are primarily employed for configuring high-resolution projection objectives of the aforementioned type.

The high prices of the materials involved and limited availability of crystalline calcium fluoride in sizes large enough for fabricating large lenses represent problems, particularly in the field of microlithography at 157 nm for very large numerical apertures, NA, of, for example, NA=0.80 and larger. Measures that will allow reducing the number and sizes of lenses employed and simultaneously contribute to maintaining, or even improving, imaging fidelity are thus desired.

Catadioptric projection objectives having at least two concave mirrors have been proposed to provide systems with good color correction and moderate lens mass requirements. The patent U.S. Pat. No. 6,600,608 B1 discloses a catadioptric projection objective having a first, purely refractive objective part for imaging a pattern arranged in the object plane of the projection objective into a first intermediate image, a second objective part for imaging the first intermediate image into a second intermediate image and a third objective part for imaging the second intermediate image directly, that is without a further intermediate image, onto the image plane. The second objective part is a catadioptric objective part having a first concave mirror with a central bore and a second concave mirror with a central bore, the concave mirrors having the mirror faces facing each other and defining an intermirror space or catadioptric

cavity in between. The first intermediate image is formed within the central bore of the concave mirror next to the object plane, whereas the second intermediate image is formed within the central bore of the concave mirror next to the image plane. The objective has axial symmetry and provides good color correction axially and laterally. However, since the reflecting surfaces of the concave mirrors are interrupted at the bores, the pupil of the system is obscured.

The Patent EP 1 069 448 B1 discloses another catadioptric projection objective having two concave mirrors facing each other. The concave mirrors are part of a first catadioptric objective part imaging the object onto an intermediate image positioned adjacent to a concave mirror. This is the only intermediate image, which is imaged to the image plane by a second, purely refractive objective part. The object as well as the image of the catadioptric imaging system are positioned outside the intermirror space defined by the mirrors facing each other. Similar systems having two concave mirrors, a common straight optical axis and one intermediate image formed by a catadioptric imaging system and positioned besides one of the concave mirrors are disclosed in Japanese patent application JP 2002208551 A and U.S. patent application Ser. No. U.S. 2002/00241 A1.

European patent application EP 1 336 887 (corresponding to U.S. 2004/0130806 A1) discloses catadioptric projection objectives having one common straight optical axis and, in that sequence, a first catadioptric objective part for creating a first intermediate image, a second catadioptric objective part for creating a second intermediate image from the first intermediate image, and a refractive third objective part forming the image from the second intermediate image. Each catadioptric system has two concave mirrors facing each other. The intermediate images lie outside the intermirror spaces defined by the concave mirrors. Concave mirrors are positioned optically near to pupil surfaces closer to pupil surfaces than to the intermediate images of the projection objectives.

In the article "Nikon Projection Lens Update" by T. Matsuyama, T. Ishiyama and Y. Ohmura, presented by B. W. Smith in: Optical Microlithography XVII, Proc. of SPIE 5377.65 (2004) a design example of a catadioptric projection lens is shown, which is a combination of a conventional dioptric DUV system and a 6-mirror EUV catoptric system inserted between lens groups of the DUV system. A first intermediate image is formed behind the third mirror of the catoptric (purely reflective) group upstream of a convex mirror. The second intermediate image is formed by a purely reflective (catoptric) second objective part. The third objective part is purely refractive featuring negative refractive power at a waist of minimum beam diameter within the third objective part for Petzval sum correction.

Japanese patent application JP 2003114387 A and international patent application WO 01/55767 A disclose catadioptric projection objectives having one common straight optical axis, a first catadioptric objective part for forming an intermediate image and a second catadioptric objective part for imaging the intermediate image onto the image plane of this system. Concave and convex mirrors are used in combination.

U.S. provisional application with Ser. No. 60/511,673 filed on Oct. 17, 2003 by the applicant discloses catadioptric projection objectives having very high NA and suitable for immersion lithography at NA>1. In preferred embodiments, exactly three intermediate images are created. A cross-shaped embodiment has a first, refractive objective part creating a first intermediate image from the object, a second, catadioptric objective part for creating a second intermediate

image from the first object, a third, catadioptric objective part for creating a third intermediate image from the second intermediate image and a fourth, refractive objective part for imaging the third intermediate image onto the image plane. The catadioptric objective parts each have one concave mirror, and planar folding mirrors are associated therewith. The concave mirrors are facing each other with the concave mirror surfaces. The folding mirrors are arranged in the middle or the intermirror space defined by the concave mirrors. The concave mirrors may be coaxial and the optical axes of the catadioptric parts may be perpendicular or at an angle with respect to the optical axis defined in the refractive imaging systems.

The full disclosure of the documents mentioned above is incorporated into this application by reference.

The article "Camera view finder using tilted concave mirror erecting elements" by D. DeJager, SPIE. Vol. 237 (1980) p. 292-298 discloses camera view finders comprising two concave mirrors as elements of a 1:1 telescopic erecting relay system. The system is designed to image an object at infinity into a real image, which is erect and can be viewed through an eyepiece. Separate optical axes of refractive system parts upstream and downstream of the catoptric relay system are parallel offset to each other. In order to build a system having concave mirrors facing each other mirrors must be tilted. The authors conclude that physically realizable systems of this type have poor image quality.

International patent applications WO 92/05462 and WO 94/06047 and the article "Innovative Wide-Field Binocular Design" in OSA/SPIE Proceedings (1994) pages 389ff disclose catadioptric optical systems especially for binoculars and other viewing instruments designed as in-line system having a single, unfolded optical axis. Some embodiments have a first concave mirror having an object side mirror surface arranged on one side of the optical axis and a second concave mirror having a mirror surface facing the first mirror and arranged on the opposite side of the optical axis such that the surface curvatures of the concave mirrors define and intermirror space. A front refractive group forms a first intermediate image near the first mirror and a second intermediate image is formed outside of the space formed by the two facing mirrors. A narrow field being larger in a horizontal direction than in a vertical direction is arranged off-set to the optical axis. The object side refractive group has a collimated input and the image side refractive group has a collimated output and entrance and exit pupils far from telecentric are formed. The pupil shape is semi-circular unlike pupil surfaces in lithographic projection lenses, which have to be circular and centered on the optical axis.

The PCT application WO 01/044682 A1 discloses catadioptric UV imaging systems for wafer inspection having one concave mirror designed as Mangin mirror.

SUMMARY OF THE INVENTION

It is one object of the invention to provide a catadioptric projection objective suitable for use in the vacuum ultraviolet (VUV) range having potential for very high image side numerical aperture which may be extended to values allowing immersion lithography at numerical apertures $NA > 1$. It is another object of the invention to provide catadioptric projection objectives that can be build with relatively small amounts of optical material.

As a solution to these and other objects the invention, according to one formulation, provides a catadioptric projection objective for imaging a pattern provided in an object

plane of the projection objective onto an image plane of the projection objective comprising:

a first objective part for imaging the pattern provided in the object plane into a first intermediate image;

a second objective part for imaging the first intermediate image into a second intermediate image;

a third objective part for imaging the second intermediate image onto the image plane;

wherein a first concave mirror having a first continuous mirror surface and at least one second concave mirror having a second continuous mirror surface are arranged upstream of the second intermediate image;

pupil surfaces are formed between the object plane and the first intermediate image, between the first and the second intermediate image and between the second intermediate image and the image plane; and all concave mirrors are arranged optically remote from a pupil surface.

In designs according to this aspect of the invention a circular pupil centered around the optical axis can be provided in a centered optical system. Two or more concave mirrors in the system parts contributing to forming the second intermediate image are provided, where the used area of the concave mirrors deviates significantly from an axial symmetric illumination. In preferred embodiments exactly two concave mirrors are provided and are sufficient for obtaining excellent imaging quality and very high numerical aperture. Systems having one common unfolded (straight) optical axis can be provided which facilitate manufacturing, adjustment and integration into photolithographic exposure systems. No planar folding mirrors are necessary. However, one or more planar folding mirrors can be utilized to obtain more compact designs.

All concave mirrors are arranged "optically remote" from pupil surfaces which means that they are arranged outside an optical vicinity of a pupil surface. They may be arranged optically nearer to field surfaces than to pupil surfaces. Preferred positions optically remote from a pupil surface (i.e. outside an optical vicinity of a pupil surface) may be characterized by the ray height ratio $H = h_C/h_M > 1$, where h_C is the height of a chief ray and h_M is the height of a marginal ray of the imaging process. The marginal ray height h_M is the height of a marginal ray running from an inner field point (closest to the optical axis) to the edge of an aperture stop, whereas the chief ray height h_C is the height of a chief ray running from an outermost field point (farthest away from the optical axis) parallel to or at small angle with respect to the optical axis and intersecting the optical axis at a pupil surface position where an aperture stop may be positioned. With other words: all concave mirrors are in positions where the chief ray height exceeds the marginal ray height.

A position "optically remote" from a pupil surface is a position where the cross sectional shape of the light beam deviates significantly from the circular shape found in a pupil surface or in an immediate vicinity thereto. The term "light beam" as used here describes the bundle of all rays running from the object plane to the image plane. Mirror positions optically remote from a pupil surface may be defined as positions where the beam diameters of the light beam in mutually perpendicular directions orthogonal to the propagation direction of the light beam deviate by more than 50% or 100% from each other. In other words, illuminated areas on the concave mirrors may have a shape having a form strongly deviating from a circle and similar to a high aspect ratio rectangle corresponding to a preferred field

shape in lithographic projection objectives for wafer scanners. Therefore, small concave mirrors having a compact rectangular or near rectangular shape significantly smaller in one direction than in the other may be used. A high aperture light beam can therefore be guided through the system without vignetting at mirror edges.

Wherever the terms “upstream” or “downstream” are used in this specification these terms refer to relative positions along the optical path of a light beam running from the object plane to the image plane of the projection objective. Therefore, a position upstream of the second intermediate image is a position optically between the object plane and the second intermediate image.

According to another aspect of the invention there is provided a catadioptric projection objective for imaging a pattern provided in an objective plane of the projection objective onto an image plane of the projection objective comprising:

a first objective part for imaging the pattern provided in the object plane into a first intermediate image;

a second objective part for imaging the first intermediate image into a second intermediate image;

a third objective part for imaging the second intermediate image onto the image plane;

wherein the second objective part includes a first concave mirror having a first continuous mirror surface and a second concave mirror having a second continuous mirror surface, the concave mirror surfaces of the concave mirrors facing each other and defining an intermirror space;

wherein at least the first intermediate image is located geometrically within the intermirror space between the first concave mirror and the second concave mirror.

In this specification the term “intermediate image” generally refers to a “paraxial intermediate image” formed by a perfect optical system and located in a plane optically conjugated to the object plane. Therefore, wherever reference is made to a location or position of an intermediate image, the axial location of this plane optically conjugated to the object plane is meant.

The above aspect of invention may be understood more clearly based on the following general considerations.

As Jan Hoogland has pointed out in some publications, the most difficult requirement that you can ask of any optical design is that it have a flat image, especially if it is an all-refractive design. Providing a flat image requires opposing lens powers and that leads to stronger lenses, more system length, larger system glass mass, and larger higher-order image aberrations that result from the stronger lens curves.

By contrast to this, allowing a system to have a curved image automatically leads to low lens powers, weaker curves, a more compact design with much less glass mass, and much smaller higher-order image aberrations.

Shafer has shown a lens design with a curved image that only uses positive lenses (and no aspherics) and has very good performance. A group of 4 or 5 weak positive lenses in front can provide correction of spherical aberration and coma, and a thick positive immersion lens can provide astigmatism correction. The image is quite curved.

However, a flat image is essential for lithography. Therefore the question then becomes how to provide this with the least disturbance of the good properties that result when a curved image is allowed.

Some classical lens types like the Cooke Triplet and the Double-Gauss designs achieve a flat image by putting strong negative power in the middle of the design. But that completely destroys all the benefits that were just listed of having a curved image, and the lens powers have to be strong and the curves lead to bad higher-order aberrations.

A much better solution is provided by the classical field-flattened Petzval lens design, where a strong negative lens is placed just in front of the image, the closer the better. This negative lens, at the very end of the design, then provides all the image flattening means of the design and the rest of the design has weak curves, low lens powers, small glass volume, etc. In addition, the aberration correction performance is extremely high. That is why this design form was used for the extremely high resolution aerial reconnaissance lenses of the 1960's.

However, this great design cannot be used in lithography since putting a strong negative lens right before the image leads to an exit pupil location that is very far from telecentric. And a telecentric exit pupil is always required in lithography.

Possibly the only way a field-flattened Petzval lens can be given a telecentric exit pupil is to move the aperture stop very far out in front of the design, far away from where it wants to be for good higher-order aberration correction. By contrast some other design types, like the Double-Gauss, can be modified to have a telecentric exit pupil without too much change in the aperture stop position, compared to its preferred location. So because of this telecentric exit pupil requirement in lithography, one is forced to abandon the best design form and move to less desirable ones.

The invention considers these aspects and provides a good compromise solution.

One can keep all the many benefits of a curved image design if one can find some way to flatten the image, have a telecentric exit pupil, and yet keep the aperture stop close to where it most wants to be for good aberration correction.

What would be perfect is if a positive power lens could be given the opposite Petzval curvature to what it actually has. Such a “magic lens”, if it could exist, could then be placed right near the curved image of a curved image design. It would then flatten the image and would even help give a telecentric exit pupil while leaving the design's aperture stop where it wants to be.

A concave mirror is ideal for the problem. A concave mirror has positive power, like a positive lens, but the opposite sign of Petzval curvature. So a concave mirror placed right in front of the image could flatten the image of a curved image lens design, have positive power to help in providing a telecentric pupil, and have no color problems.

Unfortunately it also makes the resulting image be completely inaccessible, since it sends the light right back in the direction it came from. One solution might be to use the lens system far off-axis, and then it might be possible to have one or two reflections right near the image and have the final image “walk-off” the mirrors and lie clear outside of the incoming rays. But even a moment of study will show that this is impractical on the high-NA end of the design, or would lead to the main lens system (i.e. the image side focussing lens system) being used so far off-axis that it would have very poor performance.

The situation is much better on the other end of a lithographic design, with about 4x magnification, for example. Then the main refractive design does not have to be used off-axis as much before the low-NA image can be made to “walk-off” a mirror pair. By using two concave mirrors instead of one, the light keeps going in the same

direction and the image is accessible. The best performance results occur when the main lens system is used with the least amount of off-axis use. But having the rays get through the concave mirror pair with no vignetting is helped by using the main lens system far off-axis. These are then incompatible goals.

In order to minimize vignetting problems and to make them insensitive on the system overall numerical aperture it is favorable to have intermediate images with low NA next to all positions where two ray bundles before and after a reflection lie geometrically separated, but next to each other. The clearance is then mainly determined by the field size and scales only very poorly with numerical aperture. This is important to reach real high NA catadioptric designs.

The best solution is to not have the two mirrors be between the main lens system and its low-NA object end. That then avoids a large amount of off-axis use of the main lens in order to have no vignetting at the mirrors. The mirrors should be physically (not necessarily optically) on either side of the low-NA object. Then the main lens system can be used much closer to the optical axis. A less preferable solution is to have both mirrors be outside of the main system and its low NA end object. In either case, of the last two mentioned, there is a need to reimage the low NA object, since it is no longer the end of the complete system.

While reimaging the object to a first real intermediate image, the system magnification of this first relay system may be designed such that it is an enlarging system. This reduces more and more the NA at the intermediate image and thus relaxes the vignetting problem. The vignetting depends less and less on the system NA.

In a preferred design, there are two concave mirrors on either side (again, physically, not optically) of the low-NA object plane of the main lens system and the system is used as close to the axis as possible without mirror vignetting. Then either another refractive system or a catadioptric system, working e.g. at about 1× or 1.5× enlargement, is used to relay this buried object to another real image location.

Another solution, with both mirrors physically and optically outside of the low-NA object, gives the possibility of just these same two mirrors doing the re-imaging. But the requirement of a fairly large working distance and thick mirror substrates makes this not practical without vignetting problems that require using the main system far off-axis. So this other solution also benefits from using a separate 1× or 1.5× enlarging refractive or catadioptric relay system.

In all of these cases, a pair of concave mirrors is used to flatten the image of one or two refractive systems. No convex mirrors are used. The refractive systems can then have the benefits described of being curved image designs.

Designs according to preferred embodiments of the invention with just two reflecting surfaces, both concave, have several advantages compared with the prior art.

In contrast to prior art systems with central pupil obscuration designs according to some embodiments of the invention have small mirror sizes, no obscuration at all, no double or triple-pass lenses, and very effective field flattening of the system due to the strong mirror powers. In other embodiments, double- or triple-pass lenses may be present.

Embodiments according to the invention, which preferably have two refractive relay groups, may have about 3× or 4× reduction magnification from the refractive group near the wafer, i.e. from the third objective part, (so only high N.A. on one end) and the other refractive group (the first objective part) is low NA on both ends. As a result there is much less

lens power needed and relatively few elements are needed to get the desired aberration correction.

Some prior art systems have been found to be limited NA systems. By contrast, preferred design according to the invention have no such difficulties and can handle very high NA values close to NA=1 or above, for immersion systems. Preferably, the two intermediate images both have low NA values and there is no problem with the mirrors interfering with each other's space at their rims.

It is to be noted that it is difficult to correct some useful designs according to the present invention for axial colour. However the lenses in preferred embodiments are small enough, and their powers weak enough, so that the axial color of the new design is at an acceptable value.

Other prior art high NA catadioptric systems for lithography, either require at least one convex mirror in the design, or have multiple mirrors and tend to give very long track length designs. The use of a convex mirror, in combination with a concave mirror and some lenses, can be the basis of a catadioptric design and can make it possible to have an unobscured design that does not have to be used too far off-axis to avoid vignetting. This is a characteristic of some prior patent designs which are in-line systems with no flat fold mirrors. The catadioptric part is on the reticle end of the system. There are at least two problems with such designs. One is that the first intermediate image after the reticle has to be clear of the concave mirror, and the light rays leaving the convex mirror tend to have relatively steep angles with respect to the optical axis in order to clear the edge of the concave mirror without vignetting. Some field lenses or field mirrors are then required to catch these rays and bend them back towards the optical axis and the main focusing lens group. These field lens or mirrors have to be quite large and strong in power to catch the rays and reimage the pupil towards the main focusing lens group. If they are field lenses, then they are large in diameter, have strong positive power, and result in an excess of glass volume in the design. In addition they have a lot of positive power and make further difficulties in correcting the Petzval curvature of the system. If, instead, field mirrors are used then they have to be quite large in diameter and it is difficult to configure them to avoid vignetting of the rays. They do, however, help with Petzval correction since they have the opposite sign from field lenses. The second problem with these kinds of system is that the convex mirror in the system has the wrong sign of Petzval curvature to help with image flattening. This then tends to lead to 4 or 6 mirror systems in order to find a way with several mirrors to provide the system with enough good Petzval correction from mostly concave mirrors so that this burden does not fall entirely on the main focusing lens group.

Preferred embodiments of the invention, by contrast, do not have any convex mirror and have some characteristics that allow it to work quite close to the optical axis without obscuration or vignetting. This then means that the intermediate image size is not so large and the field lenses in the design do not have to be too large. Since there is no convex mirror, but just two concave mirrors, the new design is quite simple compared to the multi-mirror systems of the prior art. Its two concave mirrors may provide just the right amount of Petzval correction for the lenses in the system, which may be almost all positive, and the resulting design has a relatively short track length, small size elements, small glass volume, very good aberration correction, and the capability of working with very high immersion NA values.

There are other particularly useful features specific to the new design according to the invention. As the NA value of

the design is increased, it makes almost no difference to the sizes of the mirrors, or how close the design can work to the optical axis. All other in-line designs from the prior art have to keep working further and further off-axis, as the NA is increased, in order to avoid vignetting and obscuration. That leads to worse high-order aberrations, a drop in performance, and larger element sizes in the catadioptric part. The new design is quite unusual in not having that problem.

An alternative to embodiments having one common straight optical axis is provided by catadioptric designs which have at least one flat fold mirror. Then part of the optical path is folded, e.g. at 90 degrees to the optical axis, and then brought back and refolded back again so that the reticle and wafer are parallel. The input and output axis (i.e. object and image side part of the optical axis) may be co-axial, in some embodiments, or have a lateral off-set in some other embodiments.

Such designs can have just one powered mirror in the system, which is a concave mirror, and two flat fold mirrors. Some, designs, like the design disclosed in U.S. provisional application with Ser. No. 60/511,673 filed on Oct. 17, 2003 by the applicant, have two concave mirrors and two flat fold mirrors. These folded designs can have many of the good properties of the new design according to the invention that is being discussed here. However, there may occur polarization problems with these fold mirrors and that makes the preferred embodiments, with no fold mirrors, very attractive.

In some embodiments there is at least one lens having a free entry surface and a free exit surface arranged within the intermirror space, wherein the lens is transited at least twice in the optical path between an intermediate image and a concave mirror or vice versa. Such mirror-related lens may have negative refractive power and may be designed as a meniscus lens having a sense of curvature similar to the concave mirror to which it is assigned. Color correction can be positively influenced this way. The lens may be designed as a truncated lens being arranged exclusively on the side of the optical axis where the associated concave mirror is situated. If a mirror-related lens is extended across the optical axis, the lens may be transited three times by the radiation, thus increasing optical effect without significantly increasing lens mass. One or both concave mirrors may have mirror-related lenses.

In some embodiments the first concave mirror and the second concave mirror are designed to have essentially the same or exactly the same curvature. This allows to manufacture the concave mirrors simultaneously from the same blank material such that firstly a mirror blank for the first and second concave mirror is manufactured and that, afterwards, the mirror blank is separated into two truncated mirrors used as the first and second concave mirror. Manufacturing can be facilitated and more cost effective this way. Likewise, lens material used for two similar truncated mirror-related lenses can be manufactured from one lens blank, which is shaped first and then separated into two truncated lenses. Systems having catadioptric subgroups which are designed identically or almost identically and which can be arranged symmetrically with respect to each other can be provided this way at reasonable costs for manufacturing.

In some embodiments at least one mirror surface of a concave mirror is aspheric. In some embodiments, concave surfaces of both concave mirrors are aspheric. Aspheric concave mirrors facilitate optical correction and allow to reduce lens mass.

In some embodiments it has been found useful to have at least one lens arranged between an intermediate image and

the associated concave mirror, wherein at least one surface of the lens is aspheric. The aspheric surface may be the surface facing the intermediate image. Field aberrations can be corrected effectively this way.

In some embodiments both concave mirrors have spherical mirror surfaces, thus facilitating manufacturing and improving optical performance. It has been found useful if the following condition is fulfilled: $1 < D / (|c_1 + c_2|) \cdot 10^{-4} < 6$. Here, D is a maximum diameter of a lens element of the third objective part in [mm] and c_1 and c_2 are the curvatures of the concave mirrors in $[\text{mm}^{-1}]$. If this condition is fulfilled, then there is an optimum balance between the positive power in the third imaging system and the Petzval correction due to the concave mirrors in the projection objective. This condition applies for both spherical and aspherical concave mirrors.

As the basic shape and, if applicable, the aspheric character of a concave mirror strongly influences optical performance, ways of manufacturing of concave mirrors are desired in order to produce high quality mirrors having defined optical properties. It has been found that relatively "flat" concave mirrors, i.e. concave mirrors having a relatively shallow depth on the concave side, can be manufactured with particularly high optical quality if the relation $p_{max} < 0.22R$ holds where $p_{max} = R - (R^2 - D^2/4)^{0.5}$. In this relation, R is the curvature radius of the aspherical mirror surface and D is the diameter of the aspherical mirror. Preferably, the condition $D \leq 1.3R$ or, more preferably, the condition $D \leq 1.2R$ is fulfilled. Parameter p denotes the "sagitta" or "rising height" of a point on an optical surface. This parameter is sometimes also denoted SAG (for sagitta) in the literature. Sagitta p is a function of the height h, i.e. the radial distance from the optical axis, of the respective point.

Generally it may be preferred from a manufacturing point of view to make the curvatures of the concave mirrors at the vertex of the mirror surface (vertex curvature) as similar as possible. If the vertex curvature radii of the first and second mirrors are denoted R1 and R2, preferably the following condition holds: $0.8 < |R1/R2| < 1.2$.

Some embodiments are designed such that the first intermediate image is located geometrically within the intermirror space whereas the second intermediate image is arranged outside the mirror space. The first and second objective parts can then be catadioptric objective parts, wherein the first concave mirror is part of the first objective part creating the first intermediate image, whereas the second concave mirror contributes to forming the second intermediate image from the first intermediate image by the second objective part.

A mirror group defined by the first and second concave mirrors facing each other can have a mirror group entry and a mirror group exit, each positioned next to the closest concave mirror closed to an edge of a concave mirror faced in the optical axis. Pupil surfaces of the projection objective can be arranged in the vicinity of the mirror group entry and the mirror group exit such that the mirror group performance a pupil imaging between the mirror group entry and the mirror group exit. The first and second concave mirror can then be disposed on one side of the optical axis. In other embodiments where field surfaces are in the vicinity of the mirror group entry and mirror group exit, the first and second concave mirror may be positioned at opposite sides of the optical axis.

According to another aspect of the invention a projection objective is provided having a first and at least one second concave mirror, wherein the first concave mirror has a first aspheric mirror surface and the second concave mirror has

a second aspheric mirror surface, and wherein the first and second mirror surfaces have essentially the same aspheric shape. The aspheric shapes may be identical, i.e. may be described by identical aspheric constants and basic spherical radius. This aspect of the invention may be utilized in embodiments where all concave mirrors are arranged optically remote from the pupil surface, particularly where exactly two concave mirrors are used. However, the advantages may also be used in projection objectives where one or more concave mirrors are positioned in a pupil surface or optically near a pupil surface. If the first and second mirror surface have essentially the same or identical aspheric shape, manufacturing can be simplified since the aspheric shapes can be manufactured using essentially the same grinding and polishing steps or other steps for removing material from a spheric basic shape. Further, the testing process utilized during manufacturing of the aspheric surfaces can be organized cost-efficient since the same testing device for characterizing the aspheric shape can be used for testing more than one concave mirror surface. In that sense, the term "essentially the same aspheric shape" is to be understood to encompass aspheric surface shapes, which can be tested by the same optical testing device. If applicable, the surface shapes may be similar in that sense that the same optical testing device can be used, but with different working distance.

In one embodiment, the second objective part has two concave mirrors, each having an aspheric surface, wherein the first and second mirror surfaces have essentially the same aspheric shape. In one embodiment, the second objective part of this type is a catoptric objective part, i.e. consisting of only two concave mirrors having aspheric mirror surfaces which have essentially the same aspheric shape. Catadioptric second objective parts of this type are also possible.

According to another aspect, the invention provides a catadioptric projection objective having at least one concave mirror, where the mirror surface of the concave mirror has a parabolic shape. In an embodiment, two concave mirrors are provided, wherein at least one of the concave mirrors has a parabolic shape. Utilizing a parabolic mirror (i.e. a concave mirror where a meridian of the mirror is parabolic) has proven advantageous particularly with regard to testing the aspheric surface shape of the mirror. A parabolic mirror collects parallel incident light into one single focus, whereby parallel light rays impinging on the parabolic mirror surface are collected free of spherical aberration in one focal point. Parabolic mirrors of this type can easily be tested optically using comparatively simple optical testing devices designed for creating a test beam having a planar wave front. Optical testing devices with simple construction can be used, thereby making the testing of the aspheric mirror cost-effective.

Whereas optical properties are essential for obtaining the desired function of a projection objective, other factors related to the costs involved for manufacturing the optical system and/or factors influencing the overall size and shape of the optical system may be critical. Also, aspects of lens mounting and incorporation of lens manipulators must be considered. One class of embodiments is particularly advantageous in this respect in that projection objectives having a small number of lens elements, particularly in the first objective part, are provided. In one embodiment, the first objective part has positive lenses only. The term "lens" as used here is meant to designate optical elements having substantive refractive power. In that respect, a plate having essentially parallel plate surfaces is not a lens and may,

therefore, be inserted in addition to the positive lenses. Using positive lenses only is enabling for providing axially compact first objective parts having relatively small maximum lens diameter. In one embodiment, the first objective part has only six lenses having substantial refractive power. One or more aspheric surfaces may be provided in the first objective part. By using suitable aspheric shapes of aspheric lens surfaces a compact design can be obtained. As a tendency, the first objective part can be designed more compact the more aspheric surfaces are used. In preferred embodiments a ratio between a number of lens element and a number of aspheric surfaces is less than 1.6. In one embodiment, a first lens element of the first objective part immediately following the object plane has an aspheric surface facing the object plane, wherein the aspheric surface is essentially flat having a local radius R of curvature where $R > 300$ mm at each point of the aspheric surface. Object side telecentricity and an effective correction of field aberration, such as distortion, can be obtained this way.

A compact shape of a dioptric system can also be facilitated if all negative lenses (i.e. lenses with substantial negative refractive power) are arranged optically remote from a pupil plane. With other words, negative lenses optically near a pupil plane should be avoided if a design is to be optimized in respect to a compact shape.

Aspheric surfaces provided on optical elements, such as lenses, mirrors and/or essentially planar faces of plates, prisms or the like can be utilized to improve both the correction status and the overall size and material consumption of an optical system. Optimum surface shapes of aspheric surfaces may be derived from theoretical considerations and/or numerical calculations. However, whether or not an optical system can be manufactured depends among other factors on the question whether or not an aspherical surface can actually be manufactured in the desired shape with the necessary optical quality. Feasibility studies of the inventors have shown some essential rules governing the use of aspheric surfaces in optical systems, particularly in high-resolution projection objectives suitable for microlithography.

According to one embodiment, the projection objective has at least one optical element having an aspherical surface with a surface shape free of inflection points in an optically used area of the aspheric surface. In a rotationally symmetric aspheric surface an "inflection point" is characterized as a point along a meridional direction where a sign change occurs in the local curvature of the aspherical surface. With other words, an inflection point is found geometrically between a locally convex surface region and a locally concave surface region of an aspheric surface. When a plurality of optical elements having at least one aspherical surface is provided, it is preferred that all aspheric surfaces have surface shapes which are free of inflection points. As a compromise, it may be useful to design a system such that at least 50% or 60% or 70% or 80% or 90% of the aspheric surfaces are free of inflection points. Avoiding inflection points on an aspheric surface has proven to improve the optical quality of the finished aspheric surface when compared to aspherical surfaces including inflection points. It is contemplated that the material removing effects of surface preparation tools can be made more uniform if inflection points are avoided. On the other hand, if a polishing tool is acting on a surface area including an inflection point, the material removing action of the tool on either side of the inflection point may differ considerably, thus leading to irregularities in the optical quality of the finished surface.

According to another aspect of the invention the projection objective includes a plurality of optical elements having at least one aspheric surface, wherein all aspheric surfaces have a surface shape free of extremal points out-side the optical axis, wherein an extremal point is defined by the following equations:

$$\frac{dp}{dh} = 0 \text{ and } \frac{d^2p}{dh^2} \neq 0.$$

In this equation, the parameter "p" represents a distance, measured parallel to the optical axis of an optical element, of a point at height h from the vertex of the surface (positioned on the optical axis) as explained in connection with the equation describing the mathematical description of the aspherical surfaces given above. The parameter p(h) is also denoted as "sagitta" or "rising height" of a point on an optical surface. Based on these considerations, an "extremal point" is a maximum or a minimum of the function p(h), respectively. Studies of the inventors have revealed that extremal points outside the optical axis (where h=0) may be critical during manufacturing of the aspherical surfaces since, in the region of extremal points, the material removing action of tools used for finishing may differ significantly from the action imposed on areas surrounding the extremal point, whereby non-uniform optical surface quality may result.

This condition should be obeyed in an area including the optically utilized area (defined by the optically used radius h_{opt}) but going beyond that area up to a maximum height $h_{max} > h_{opt}$, where $h_{max} = h_{opt} + OR$ and where OR is the radial width of an "overrun area" adjacent to the optically utilized area, where a rotary tool will be in contact with the optical surface when the periphery of the optically used area is polished. Typical widths of the overrun area are dependent on the tool dimensions and may be in the order of 5 mm to 15 mm.

Whereas extremal points on aspheric surfaces may be critical from a manufacturing point of view, extremal points may be desirable from an optical point of view to provide a desired change of refractive power of an aspheric surface in radial (meridional) direction. As a compromise, it has been found advantageous that aspheric surfaces having at least one extremal point should be essentially flat cross the entire usable diameter. With other words, the basic shape of the aspherical surface having at least one extremal point should be a plane or should have only small deviations from a plane. In that respect, projection objectives are preferred with at least one aspheric surface having at least one extremal point, where the following condition holds for these aspheric surfaces:

$$|p(h)| < p_{max},$$

where $p_{max} = 0.5$. More preferably, $p_{max} = 0.25$.

The preferred conditions for aspheric surfaces given above have been derived from feasibility studies performed on certain embodiments of this invention. However, the conditions may also be utilized on other types of optical systems having optical elements with aspheric surfaces. Therefore, these aspects of the invention are useful independent of other features of preferable embodiments of the invention.

According to another aspect of the invention the first objective part includes a concave mirror and at least one

additional mirror having a curved mirror surface, where curved mirror surfaces of the concave mirror and the additional mirror are facing each other. In this embodiment two mirrors having curved mirror surfaces contribute to the formation of the first intermediate image. Preferably, first objective parts of this type are catadioptric, i.e. at least one lens is provided in addition to the concave mirror and the additional mirror. The concave mirror and the additional mirror preferably share a common straight optical axis coinciding with the optical axes of the second and third objective part such that all objective parts share a common straight optical axis. Preferably first objective parts of this type are designed as enlarging imaging system. In some embodiments the additional mirror is a convex mirror having a convex mirror surface compensating as at least partially the effect of the concave mirror of that objective part. Preferably, first objective parts of this type are combined with a second objective part including a first and a second concave mirror, the concave mirror surfaces of which are facing each other and define an intermirror space. Whereas typically the first intermediate image may be positioned outside that intermirror space in these embodiments, the second intermediate image may be positioned inside the intermirror space. Embodiments having at least three concave mirrors, preferably exactly three concave mirrors, distributed in two objective parts (first objective part and second objective part) may be designed such that all concave mirrors are arranged optically remote from a pupil surface. However, if desired, it is also possible that at least one concave mirror, particularly the concave mirror positioned in the first objective part, is positioned optically near a pupil surface.

In embodiments of this type the correction capabilities provided by concave mirrors can be advantageously distributed between two objective parts separated by an intermediate image, whereby a good balance and compensation between the correcting actions can be obtained. It is also possible to design the first and second objective part such that certain correction effects supported by concave mirrors are present twice in the optical path. The correcting means may, however, be arranged in optical positions where they have different optical effects since the heights of principal ray (chief ray) and marginal ray may be different for different concave mirrors in different objective parts. All advantages provided by in-line-arrangement of the optical elements (one common straight optical axis) can be preserved.

The previous and other properties can be seen not only in the claims but also in the description and the drawings, wherein individual characteristics may be used either alone or in sub-combinations as an embodiment of the invention and in other areas and may individually represent advantageous and patentable embodiments.

BRIEF DESCRIPTION OF THE DRAWINGS

FIG. 1 is a longitudinally sectioned view of a first embodiment of a projection objective according to the invention;

FIG. 2 is a representation of an inner off-axis beam passing through the system of FIG. 1,

FIG. 3 is a representation of an outer off-axis beam passing through the system of FIG. 1;

FIG. 4 is a longitudinally sectioned view of a second embodiment of a projection objective according to the invention;

15

FIG. 5, 6 are schematic diagrams showing footprints of beams on the concave mirrors of the embodiment shown in FIG. 4;

FIGS. 7, 8 and 9 show variants of the embodiment of FIG. 4 having different NA values and different positions of the aperture stop;

FIG. 10, 11 show a schematic representation and a lens section, respectively, of a third embodiment of a projection objective according to the invention;

FIG. 12, 13 show a schematic representation and a lens section, respectively, of a fourth embodiment of a projection objective according to the invention;

FIG. 14 shows a perspective view of the catadioptric objective part of the third embodiment to demonstrate the mirror geometry;

FIG. 15 shows a schematic representation of another embodiment having double-passed lenses between concave mirrors and an oblique field (FIG. 15a);

FIG. 16 shows a lens section through an embodiment constructed according to FIG. 15;

FIG. 17 shows a lens section of another embodiment constructed according to the principles shown in FIG. 15;

FIG. 18 shows a schematic representation of an embodiment having triple-passed lenses between the concave mirrors;

FIG. 19 shows a lens section of an embodiment constructed according to the principles shown in FIG. 18;

FIG. 20 shows a lens section through an embodiment having a mirror-related lens close to one of the concave mirrors;

FIG. 21 shows a lens section through another embodiment of a projection objective according to the invention;

FIG. 22 shows a lens section of another embodiment of a projection objective according to the invention having similar, shallow concave mirrors;

FIG. 23 shows a lens section of another embodiment of a projection objective according to the invention having similar, shallow concave mirrors;

FIG. 24 shows a diagram for defining the plunging depth of a concave mirror;

FIG. 25 shows a lens section of another embodiment of a projection objective according to the invention having only one intermediate image in the intermirror space and pupil planes close to the entrance and exit of the mirror group;

FIG. 26 shows an enlarged view of a section of the embodiment shown in FIG. 25 between the object plane and the first intermediate image;

FIG. 27 shows a lens section of an embodiment of the invention, where a catoptric second objective part has two concave mirrors having exactly the same aspheric shape;

FIG. 28 show a lens section of an embodiment having a catoptric second objective part, where the first concave mirror is designed as a parabolic mirror;

FIG. 29 is a schematic diagram showing a testing device for optically testing a parabolic mirror;

FIGS. 30-32 show embodiments of projection objectives having a compact first objective part having positive lenses only and different numbers of aspheric surfaces;

FIG. 33 shows schematic diagrams of a conventional aspheric surface having an inflection point;

FIG. 34 shows a lens section of an embodiment where all aspheric surfaces are free of inflection points;

FIG. 35 is a schematic diagram showing aspheric surfaces having extremal points;

FIG. 36 shows a lens section of an embodiment of a projection objective where problems due to the existence of extremal points are avoided;

16

FIG. 37 shows a lens section of another embodiment having a small number of aspheric surfaces;

FIG. 38 shows a lens section of another embodiment having a small number of aspheric surfaces;

FIG. 39 shows a lens section of an embodiment having a catadioptric first objective part including two curved mirrors and a catadioptric second objective part having two concave mirrors; and

FIG. 40 shows a lens section of another embodiment having a first objective part with two curved mirrors and a catadioptric second objective part having two concave mirrors.

DETAILED DESCRIPTION OF THE PREFERRED EMBODIMENTS

In the following description of preferred embodiments of the invention, the term “optical axis” shall refer to a straight line or sequence of straight-line segments passing through the centers of curvature of the optical elements involved. The optical axis is folded by folding mirrors (deflecting mirrors) or other reflective surfaces. In the case of those examples presented here, the object involved is either a mask (reticle) bearing the pattern of an integrated circuit or some other pattern, for example, a grating pattern. In the examples presented here, the image of the object is projected onto a wafer serving as a substrate that is coated with a layer of photoresist, although other types of substrate, such as components of liquid-crystal displays or substrates for optical gratings, are also feasible.

Where tables are provided to disclose the specification of a design shown in a figure, the table or tables are designated by the same numbers as the respective figures.

FIG. 1 shows a first embodiment of a catadioptric projection lens 100 according to the invention designed for ca. 193 nm UV working wavelength. It is designed to project an image of a pattern on a reticle arranged in the object plane 101 into the image plane 102 on a reduced scale, for example, 4:1, while creating exactly two real intermediate images 103, 104. A first refractive objective part 110 is designed for imaging the pattern in the object plane into the first intermediate image 103 at an enlarged scale, a second, catadioptric objective part 120 images the first intermediate image 103 into the second intermediate image 104 at a magnification close to 1:1, and a third, refractive objective part 130 images the second intermediate image 104 onto the image plane 102 with a strong reduction ratio. The second objective part 120 comprises a first concave mirror 121 having the concave mirror surface facing the object side, and a second concave mirror 122 having the concave mirror surface facing the image side. The mirror surfaces are both continuous or unbroken, i.e. they do not have a hole or bore. The mirror surfaces facing each other define a catadioptric cavity 125, which is also denoted intermirror space 125, enclosed by the curved surfaces defined by the concave mirrors. The intermediate images 103, 104 are both situated inside the catadioptric cavity 125, at least the paraxial intermediate images being almost in the middle thereof well apart from the mirror surfaces.

Each mirror surface of a concave mirror defines a “curvature surface” or “surface of curvature” which is a mathematical surface extending beyond the edges of the physical mirror surface and containing the mirror surface. The first and second concave mirrors are parts of rotationally symmetric curvature surfaces having a common axis of rotational symmetry.

For improved clarity of the beam path through the optical system, FIGS. 2 and 3 show two distinguished beam bundles originating from the off-axis object field. The beam bundle in FIG. 2 originates from an object point closest to the optical axis, whereas in FIG. 3 the beam bundle originates from an object point farthest away from the optical axis. The situation of the intermediate images almost in the middle between the concave mirrors can be clearly seen in this representation. In FIG. 2, the shown positions of the intersections of the crossing light beams between the mirrors are close to the positions of the paraxial intermediate images. In contrast, in FIG. 3 the shown positions or zones of the intersections of the crossing light beams between the mirrors are further offset from the positions of the paraxial intermediate images.

The system 100 is rotational symmetric and has one straight optical axis 105 common to all refractive and reflective optical components. There are no folding mirrors. The concave mirrors have small diameters allowing to bring them close together and rather close to the intermediate images lying in between. The concave mirrors are both constructed and illuminated as off-axis sections of axial symmetric surfaces. The light beam passes by the edges of the concave mirrors facing the optical axis without vignetting (compare e.g. FIG. 4 or FIG. 7-9).

A maximum light beam height at the concave mirrors is almost the same as the maximum light beam height within the third objective part. Preferably, the maximum light beam height at the concave mirrors is less than the 1.5 fold or less than the 1.2 fold of the maximum light beam height within the third objective part. This allows constructions wherein all light beams within the projection objective are located within a space defined as a cylinder around the optical axis of said third objective part, extending from the object plane to the image plane and having a maximum radius of the 1.5 fold, preferably the 1.2 fold, of a maximum beam height within said third objective part.

The system has good lateral color correction, whereas axial color is not entirely corrected. In this embodiment, both concave mirrors are designed as Mangin mirrors. Each Mangin mirror consists of a negative meniscus lens with a mirrored convex surface. The undercorrected spherical aberration of the mirror is offset by the overcorrected spherical aberration of the negative lens. Both concave mirrors have very little refractive power. The concave mirrors may also be designed as simple mirrors (without meniscus lens), then the mass of transparent optical material is less but it may be necessary to cut the mirrors.

The projection objective is designed as an immersion lens. The correction status is about 9 milliwaves at 1.1 NA over a 26.5.0 mm² field. The field radius is 65 mm. No aspheric surfaces having a departure from a best fitting sphere (deformation) larger than 1.0 mm are necessary. A maximum diameter of 220 mm for the largest elements shows the potential for a low lens mass consumption. The design has 1160 mm track length (axial distance between object plane and image plane) and small glass mass. The last lens next to the image plane is made of calcium fluoride, for immersion.

This new design has very good lateral colour correction but none for axial colour. But the small lens sizes give it less axial colour than an all-refractive design of the same NA. The pupil aberration is well corrected and the chief rays are almost exactly telecentric on both ends.

The design with only two reflections and the small glass volume has no problem with obscuration, so the mirrors can

be a good size—not so large—and their strong power provides almost all the Petzval correction of the system. In the embodiment the two intermediate images are almost exactly in the middle of the catadioptric cavity.

A modification not shown here has a first refractive objective part and a third refractive objective part quite similar to those disclosed in U.S. provisional application with Ser. No. 60/511,673 filed on Oct. 17, 2003 by the applicant. The corresponding specification is incorporated by reference.

This basic design has potential to get by on even smaller amounts of optical material volume, especially if the Mangin mirrors have their glass removed. (Compare FIG. 4).

In FIG. 4 a second embodiment is shown. Features or feature groups identical or similar in structure and/or function to those in FIG. 1 are denoted by similar numerals increased by 100.

The projection objective 200 is designed as an immersion lens for $\lambda=193$ nm having an image side numerical aperture NA=1.20 when used in conjunction with a high index immersion fluid, e.g. pure water, between the exit face of the objective and the image plane. The field size is 26.5.0 mm². The specifications for this design are summarized in Table 4. The leftmost column lists the number of the refractive, reflective, or otherwise designated surface, the second column lists the radius, r, of that surface [mm], the third column lists the distance, d [mm], between that surface and the next surface, a parameter that is referred to as the “thickness” of the optical element, the fourth column lists the material employed for fabricating that optical element, and the fifth column lists the refractive index of the material employed for its fabrication. The sixth column lists the optically utilizable, clear, semi diameter [mm] of the optical component. A radius r=0 in a table designates a planar surface (having infinite radius).

In the case of this particular embodiment, twelve surfaces, namely surfaces 2, 3, 8, 12, 15, 16, 17, 19, 22, 30, 33 and 35 in table 4, are aspherical surfaces. Table 4A lists the associated data for those aspherical surfaces, from which the sagitta or rising height p(h) of their surface figures as a function of the height h may be computed employing the following equation:

$$p(h) = \left[\frac{(1/r)h^2}{1 + \sqrt{1 - (1+K)(1/r)^2 h^2}} \right] + C1 \cdot h^4 + C2 \cdot h^6 + \dots$$

where the reciprocal value (1/r) of the radius is the curvature of the surface in question at the surface vertex and h is the distance of a point thereon from the optical axis. The sagitta or rising height p(h) thus represents the distance of that point from the vertex of the surface in question, measured along the z-direction, i.e., along the optical axis. The constants K, C1, C2, etc., are listed in Table 4A.

Since the objective has 17 lenses, more than 50% or more than 60% of the lenses are aspheric lenses.

Like the embodiment of FIG. 1, there are no folding mirrors leaving a straight, unfolded optical axis common to all optical components. In contrast to the first embodiment, the two concave mirrors 221, 222 facing each other are simple mirrors instead of Mangin-mirrors, which allows to reduce the overall mass of the system. In order to demonstrate the path of the light transiting the catoptric (purely reflective) group 220, FIGS. 5 and 6 show the “footprints” of the beams on the concave mirrors. In FIG. 5, footprints at the position of the first concave mirror 221 are shown. The lower group of elliptic lines represent beams reflected at the first concave mirror 221, and the upper group of elliptic lines

represent the beams coming from the second concave mirror **222** towards the second refractive part **230**. In FIG. **6**, the footprints at the position of the second concave mirror **222** are shown. The lower part represents beams running from the first refractive part **210** to the first concave mirror **221**, whereas the upper elliptic lines represent the beams reflected at the second concave mirror **222** and running to the image plane. It can be seen that the used areas on the mirrors have simple contiguous shapes such that the mirrors may be fabricated, for example, as a rectangular mirror, which is easy to mount.

It is a characterizing feature that the overall cross sectional beam shape at a concave mirror deviates significantly from a circular shape found at pupil positions. The beam diameters in mutually perpendicular directions have a ratio of about 1:3 in this embodiment, where the diameter in scan direction y is less than 50% or 30% of the diameter in a cross scan direction x . The beam shape resembles the rectangular field shape indicating that the concave mirror is closer to a field surface than to a pupil surface, i.e. the concave mirror is positioned optically remote from a pupil surface. Small, narrow mirrors can therefore be used as concave mirrors. This facilitates guiding the light flux past the concave mirrors at one side without vignetting even when the numerical aperture is high.

Generally, in embodiments according to the invention, the size of the concave mirrors is not directly coupled to the numerical aperture such that very high values of NA, e.g. $NA > 1.3$ or $NA > 1.4$ can be obtained without unduly increasing the mirror size.

In FIG. **7** to **9** some beneficial variants of the second embodiment are shown. Features or feature groups identical or similar in structure and/or function to those in FIG. **4** are denoted by similar numerals. All variants are designed as immersion lens for $\lambda = 193$ nm having an image side numerical aperture $NA > 1$ when used in conjunction with a high index immersion fluid, e.g. pure water, between the exit face of the objective and the image plane. The field size is 26 mm \sim 5.0 mm. Specifications are given in Tables 7 and 7A for FIG. **7**, and in tables 8 and 8A for FIG. **8** and for FIG. **9**. The designs in FIGS. **8** and **9** are the same, the difference lies in the position of the aperture stop A.

The variant of FIG. **7** ($NA = 1.1$) is characterized by the fact that the used areas on the concave mirrors are smaller than in the embodiment of FIG. **4**. Consequently, the sizes of the rectangularly shaped concave mirrors may be further reduced.

The variant of FIG. **8** ($NA = 1.15$) is characterized by the fact that the aperture stop A is positioned in the third, purely refractive part **230** in the region of maximum beam diameter. By contrast, in the closely related variant in FIG. **9** ($NA = 1.15$) the aperture stop A is positioned in the first refractive objective part **210**. This demonstrates that the designs allow flexibility as to where the aperture stop can be placed.

The embodiments described above are characterized by a straight, unfolded optical axis common to all optical elements. A potential problem of such designs may be that the mounts provided for the concave mirrors may lead to a long track length or may interfere with the beam path. In the following, embodiments comprising at least one planar folding mirror are shown as design alternatives to obtain compact designs.

In FIG. **10** a third embodiment is shown. Features or feature groups identical or similar in structure and/or function to those in FIG. **1** are denoted by similar numerals

increased by **200**. FIG. **11** represents a longitudinal sectional view of an embodiment designed on the basis depicted in FIG. **10**.

The embodiment of a catadioptric projection objective **300** in FIG. **10** is similar to some of the above mentioned embodiments in that it comprises a first, refractive objective part **310** for creating a first intermediate image **303**, a second, catoptric objective part **320** for creating a second intermediate image **304** from the first intermediate image, and a third, refractive objective part **330** for re-imaging the second intermediate image onto the image plane **302**. The second objective part may include at least one lens such that it becomes a catadioptric objective part.

In contrast to the embodiments shown above, the second objective part **320** includes four reflective surfaces, namely two planar folding mirrors **306**, **307** and two concave mirrors **321**, **322** facing each other. The concave mirror surfaces of these mirrors define a catoptric cavity **325** inside which the folding mirrors and the intermediate images are located.

The first folding mirror **306** located immediately near the first intermediate image **303** is arranged for reflecting the radiation coming from the object plane onto the first concave mirror **321**, which reflects the light directly, i.e. without intermediate image, to the second concave mirror **322**. Light reflected from the second concave mirror strikes the second folding mirror **307** which reflects the light to the object plane, thereby creating the second intermediate image immediately near the second folding mirror. In this construction, the concave mirrors and the mounts of these mirrors are situated outside the central main part running between object plane and image plane. The concave mirrors have a common optical axis **305'** which may be exactly or almost perpendicular to the object side and image side parts **305''** and **305'''** of the optical axis, which are laterally offset in this embodiment. Inclination angles of the folding mirrors with respect to the optical axis may be 45° or may deviate significantly therefrom, e.g. by up to 5° or 10° degrees. Therefore, inclination angles between 70° and 110° may occur between the common optical axis of the concave mirrors and the object and image side part of the optical axis.

Whereas the intermediate images are geometrically situated between the concave mirrors, it is to be noted that no intermediate image lies optically between the concave mirrors. This configuration allows for small spot diameters on the concave mirrors, which is advantageous for reducing the geometric light guidance value (etendue). A pupil plane **309** lies at a distance from both concave mirrors at the position where the chief ray **308** crosses the optical axis **305'** defined by the concave mirrors. An aperture stop may be positioned here. It may be beneficial if at least one of the concave mirrors has an aspheric reflecting surface having a curvature which decreases from the optical axis to the edge of the mirror in a radial direction.

The purely refractive first objective part **310**, which transforms the off axis object field into the first intermediate image, has a first lens group LG11 with positive power and a second lens group LG12 with a positive power. An aperture stop may be provided between these lens groups where the chief ray **308** crosses the optical axis. The catoptric objective part **320** images the first intermediate image into the second intermediate image and has a pupil plane between the concave mirrors. The purely refractive third objective part **330** has a first lens group LG31 with positive power, and a second lens group LG32 with a positive power. An position for an aperture A stop lies between LG31 and LG32.

FIG. 12 shows a schematic representation of another projection objective 400 having two concave mirrors 421 and 422 and two intermediate images 403, 404. Features or feature groups identical or similar in structure and/or function to those in FIG. 10 are denoted by similar numerals increased by 100. FIG. 13 represents a longitudinal sectional view of an embodiment designed on the basis depicted in FIG. 12.

In contrast to the embodiment shown in FIGS. 10, 11, the concave mirrors 421, 422 do not share a common straight optical axis. Instead, the optical axis of the concave mirror 421 corresponds to the optical axis 405 between object plane and image plane. The optical axis of the concave mirror 422 is nearly perpendicular to the optical axis 405. The construction space for the mirror mounts lies outside the optical axis connecting object and image plane, which may be favorable. Note that the object side and the image side section of the optical axis are coaxial. As the concave mirrors both lie on one side of the optical axis 405, the first and second folding mirror can be designed as one single planar mirror 406 with a mirror face facing the concave mirrors and used twice as the light passes through. Also, the two separate concave mirrors 421, 422 can be combined to form one single concave mirror which is used twice.

FIG. 14 shows a perspective view of the catoptric objective part of the third embodiment to demonstrate the mirror geometry. It can be seen that the folding mirrors and the concave mirrors can have geometrically simple shapes since the illuminated areas are of simple form and contiguous. The concave mirrors and the folding mirrors in this embodiment have rectangular shape which facilitates mounting.

FIG. 15 shows a schematic representation of another embodiment of a projection objective 500 having features improving optical performance and features facilitating manufacturing. FIG. 16 shows a lens section of a projection objective designed according to the principles shown in FIG. 15. The specification of this embodiment is shown in tables 16 and 16A. Features or feature groups identical or similar in structure and/or function to those in FIG. 1 are denoted by similar numerals, increased by 400.

The second objective part 520 which serves to image the first intermediate image 503 into the second intermediate image 504 includes a first concave mirror 521 and a second concave mirror 522 optically downstream of the first concave mirror 521. The curvature surfaces of the first and second concave mirror have a common axis of rotational symmetry co-axial with the optical axis shared by all optical elements of the projection objective. The unbroken mirror surfaces used on the first and second concave mirror are on opposite sides of the optical axis 505. A first mirror-related lens 551 is arranged optically between the first intermediate image 503 and the first concave mirror 521 immediately in front of the first concave mirror such that it is transited twice in the optical path between the first intermediate image and the first concave mirror and in the optical path between the first concave mirror and the second concave mirror. In order to avoid influencing the optical path between the second concave mirror and the image plane the first mirror-related lens 551 is designed as a truncated lens arranged outside the optical axis. A second mirror-related lens 552 is arranged immediately in front of the second concave mirror 522 such that it is used twice in the optical path between the first and the second concave mirror and in the optical path between the second concave mirror and the image plane 502. The lens 552 is truncated such that it does not extend into the optical path between the object plane 501 and the first concave mirror 521. Both the first and second mirror related lenses

551, 552 are free standing lenses having free entrance and exit surfaces. Particularly, the lens surfaces facing the respective concave mirrors have curvatures different from the curvatures of the concave mirrors, which allows additional degrees of freedom when compared to the embodiments having Mangin mirrors (compare FIG. 1). Both mirror-related lenses 551, 552 are designed as negative meniscus lenses having a sense of curvature similar to the curvature of the associated concave mirror, i.e. having a convex surface facing the concave mirror surface of the associated concave mirror. The negative refractive power arranged immediately in front of the concave mirrors serves to improve correction of the chromatic length aberration (CHL). All optically active surfaces of the second objective part are spherical, which greatly facilitates manufacturing and improves the optical performance. Particularly, stray light may be reduced when compared to embodiments having aspheric surfaces, particularly aspheric mirror surfaces.

The field having the shape of a high aspect ratio rectangle having a width a in cross-scan direction (x-direction) and a smaller width b in scan direction (y-direction) and arranged off-axis at a distance c from the optical axis is shown in FIG. 15a. The immersion objective has image side numerical aperture $NA=1.2$ when used in conjunction with pure water as an immersion medium at 193 nm. The system is telecentric on the object and image side and essentially free of field zone aberrations.

In FIG. 17 a lens section of a variant of a system according to the principles explained in connection with FIG. 15 is shown. The specification of the 193 nm immersion lens having $NA=1.2$ is given in tables 17 and 17A. Features or feature groups identical or similar in structure and/or function to those in FIG. 1 are denoted by similar numerals, increased by 500. The second objective part 620 has aspherical negative meniscus lenses 651, 652 immediately in front of the spherical concave mirrors 621, 622 and used twice in the light path to and from the respective concave mirrors. For the sake of simplicity, each group of optical elements consisting of a concave mirror 621, 622 and the associated lenses 651, 652 immediately ahead of the respective concave mirror is denoted as "catadioptric sub-group". In the embodiment of FIG. 17 the catadioptric sub-group 621, 651 and the catadioptric sub-group 622, 652 are designed identically and arranged symmetrically with respect to each other. Particularly, the radii of the optical surfaces, the axial distances or thicknesses of the optical surfaces and the diameters of the optical surfaces of the symmetry related lenses as well as the symmetry related concave mirrors are identical. This makes it possible that the lenses 651, 652 and the mirrors 621, 622, respectively, may be manufactured simultaneously from the same blank material. Therefore, arrangements of the type exemplarily shown in FIG. 17 allow for significant reduction in costs for material and manufacturing for the optical elements used in the second, catadioptric objective part.

In a corresponding method of manufacturing optical elements for an catadioptric or catoptric objective part of a projection lens having a first concave mirror and a second concave mirror designed as truncated mirrors the first and second mirrors are fabricated such that firstly a mirror blank for the first and second concave mirror is manufactured to obtain the desired concave shape of the mirror surface and secondly the shaped mirror blank is separated into two truncated mirrors used as first and second concave mirror. The mirror blank may be a single piece cut into two pieces after surface preparation. It is also possible to join two

separate blank parts together, e.g. by wringing or cementing, prior to shaping the mirror surface. This allows easy separation after the surface preparation. The coating of the mirror substrate may be performed prior to or after separation of the mirror substrate parts. The mirror related lenses may be

manufactured correspondingly. A further difference to the embodiment shown in FIG. 16 lies in the fact that at least one of the surfaces of the lenses 651, 652 close to the respective concave mirrors has aspheric shape. In the embodiment, each concave lens surface of the lenses 651, 652 is aspheric. The aspheric surfaces arranged closed to the respective intermediate images, which are field surfaces of this system, can be designed such that a strong influence on field dependent aberrations, like distortion on the object imaging or the spherical aberration of the pupil imaging, are influenced. Generally, it may be useful to have at least one lens arranged between an intermediate image and the associated concave mirror optically near the intermediate image (upstream or downstream of the intermediate image), wherein at least one surface of the lens arranged between the intermediate image and the concave mirror is aspheric. Particularly, the lens surface facing the intermediate image may be aspheric.

In an alternative embodiment the mirror related lenses, which are truncated lenses in the embodiments of FIGS. 16 and 17, are designed as full meniscus shaped negative lenses extending across the optical axis such that they are transited three times. Specifically, lens 652 (associated to the second concave mirror 622) may extend across the optical axis 605 such that light coming from the object plane transits this lens prior to forming the first intermediate image 603 and then, on the other side of the optical axis, in the optical path between first and second concave mirror and second concave mirror and image plane. Likewise, lens 651 associated to the first concave mirror 621 may extend across the optical axis such that the lens is used twice in the optical path to and from the first concave mirrors and a third time in the optical path between the second intermediate image 604 and the image plane. In this embodiment, two aspheric surfaces transited three times upstream and downstream of an intermediate image are provided, which facilitates optical correction. In addition, mounting of the lenses is improved when compared to the mounting of truncated lenses (compare FIGS. 18 and 19).

In FIG. 18 a schematic representation of a projection objective 700 having two lenses used three times in transmission is shown. FIG. 19 shows an embodiment of this type, for which the specification is given in tables 19 and 19A. Features similar or identical to features described in detail in connection with FIG. 15 to 17 are designated with the same reference numbers, increased by 100 or 200, respectively.

The catadioptric second objective part 720 serves to image the first intermediate image 703 into the second intermediate image 704. A first mirror related lens 751 is arranged optically between the first intermediate image 703 and the first concave mirror 721, whereas, on the opposite side of the optical axis 705, the second mirror related lens 752 is arranged optically between the second concave mirror 722 and the second intermediate image 704. Both mirror-related lenses 751, 752 extend across the optical axis into the beam pass of light passing the respective concave mirrors 721, 722. Particularly, the second mirror related lens 752 extends into the beam pass between the object plane 751 and the first concave mirror 721, whereas the first mirror related lens 751 extends into the beam path into the second concave mirror 752 and the image plane. Therefore, each of the

mirror-related lenses 751, 752 is optically used three times, whereby the optical effect of a lens can be maximized and, at the same time, the consumption of optical material can be minimized. In addition, mounting of the lenses 751, 752 is facilitated when compared to a mounting of truncated lenses.

The triply passed lenses 751, 752 may preferably be designed as multi-grade lenses having a first lens zone associated with one side of the optical axis and transited twice in the optical path to and from the associated concave mirror and a second zone associated with the opposite side of the optical axis and transited once, where the first lens zone and the second lens zone have different lens surface curvature on at least one side of the lens such that the multigrade lens forms a pair of mutually independently acting lenses acting at a common location. A monolithic multigrade lens providing different optical powers on opposite sides of the optical axis may be fabricated from a single lens blank and can be mounted conventionally with a circular mount. The lens zones on either side of the optical axis may have different aspheric shape, where the aspheres are preferably based on the same spherical base shape to facilitate manufacturing. Note that the part of lens 752 closest to the first intermediate image and the part of lens 751 closest to the second intermediate image are both located close to field surfaces such that the lens surfaces are effective for correcting field aberrations, particularly if they are made aspheric.

In the embodiment shown in FIG. 19, both lenses 751, 752 with triple use are designed as negative meniscus lenses having a sense of curvature similar to the related concave mirrors and having weak negative refractive power. In other embodiments, the lenses may also be almost without optical power. In both cases, at least one lens surface may be aspheric in order to support optical correction.

In all embodiments the first, dioptric objective part serves to form the first intermediate image from a flat object field. The size and axial position of the first intermediate image as well as the aberrations associated with the first intermediate image are determined by the optical properties of the first objective part. Like in the embodiments shown above, the first objective part may be subdivided into a first lens group LG11 having positive refractive power and the second lens group LG12 having positive refractive power, wherein a pupil surface 711 of the system is disposed between the lens groups in an axial position where the chief ray 708 of the imaging intersects the optical axis. An aperture stop for determining the numerical aperture used in the imaging process may be provided in the vicinity of this pupil surface. However, in the embodiment shown in FIGS. 18 and 19, the aperture stop A is provided in the vicinity of a pupil surface optically conjugate to this pupil surface in the third, dioptric objective part. The second lens group LG12 between the pupil surface 711 and the first intermediate image includes the negative meniscus lens 752 immediately upstream of the first intermediate image.

In the embodiment of FIG. 19 the first lens group LG11 consists of a positive meniscus lens 781 having an image side concave surface and weak optical power, a negative meniscus lens 782 having an image side concave surface and weak negative power, a positive meniscus lens 783 having an object side concave surface, a biconvex positive lens 784, a positive meniscus lens 785 having an image side concave surface and a positive meniscus lens 786 having an image side concave surface immediately ahead of the pupil surface 711. The second lens group LG12 includes a meniscus shaped lens 787 having a strongly curved concave surface

facing the object, a positive meniscus lens **788** having an object side concave surface and a biconvex positive lens **789** immediately behind, and the negative meniscus lens **752** which is integral part of the mirror related second lens. The meniscus lens **787** immediately following the pupil surface and having the concave surface facing the pupil and the object plane is particularly useful for correcting spherical aberration, astigmatism and image curvature in the first objective part. The optical correction is also positively influenced by a negative-positive-doublet formed by the negative meniscus lens **782** and the positive meniscus lens **783** arranged in the divergent beam section of the first lens group LG11. The negative meniscus lens having the concave exit surface optically close to the object plane is arranged in a region where the height of the chief ray is larger than the height of the marginal ray, whereby field aberrations, like distortion, can be effectively corrected.

The embodiment of a projection objective **800** shown in FIG. 20 having a specification as given in tables 20 and 20A can be described as a variant of the embodiment shown in FIG. 19. Similar to that embodiment, a negative meniscus lens **851** is arranged immediately ahead of the first concave mirror **821**, the lens **851** being passed three times by the light beam. In contrast to the embodiment of FIG. 19, lens **851** is the only lens passed three times by the light beam. There is no negative refractive power or positive refractive power immediately in front of the second concave mirror **822**. Therefore, the mass of transparent optical material required for the catadioptric objective part is smaller than in the embodiment shown in FIG. 19. The first objective part has magnification $|\beta_1| \approx 1.9$.

In FIG. 21 another embodiment of a projection objective **900** is shown which is generally designed according to the principles explained in detail in connection with FIG. 15. The specification is given in tables 21 and 21A. Reference numerals are similar, but increased by 400. Particularly, to each concave mirror **921**, **922** is as signed a negative meniscus lens **951**, **952** immediately in front of the concave mirror optically between the respective concave mirror and an intermediate image upstream or downstream of the concave mirror. Each negative meniscus lens **951**, **952** is designed as a truncated lens arranged only at the side of the optical axis where the associated concave mirror is positioned. Therefore, the mirror-related lens is passed twice by the light. The first objective part **910** can be subdivided into two lens groups, lens group LG11 being arranged between the object plane and the pupil plane **911**, whereas lens group LG12 is arranged between the pupil plane and the first intermediate image **903**. Like in the embodiment shown in FIG. 19, the first lens group LG11 includes a negative-positive-doublet **982**, **983**, the negative meniscus **982** being arranged close to the object plane and having a concave exit side facing the image plane. The positive refractive power following this negative lens is split into two positive meniscus lenses, each having a concave side facing the object. A meniscus lens **987** having a strongly curved concave entrance side facing the object is arranged immediately downstream of the pupil plane **911**. Optically, this lens is useful for correcting spherical aberration, astigmatism and image curvature in the first objective part.

The third objective part **930** is composed of a first lens group LG31 between the second intermediate image **904** and the aperture stop A, and the second lens group LG32 between the aperture stop A and the image plane. The aperture stop is arranged between the region of largest beam diameter of the third objective part and the image plane. The biconvex positive lens **996** immediately following the aper-

ture stop A is a biaspherical lens having both the entrance side and the exit side being aspheric surfaces. The aspheric surfaces in close vicinity to each other and arranged in the convergent beam path immediately upstream of the image plane have a strong influence on aberration correction. Particularly, higher orders of spherical aberration and coma are positively influenced. There is only one negative lens **991** arranged in the third objective part. The biconvex negative lens **991** defines a shallow waist in the beam path of the third objective part. All lenses downstream of negative lens **991** are positive lenses. Avoiding negative lenses in the region of increasing and large beam diameters of the third objective part allows to keep the beam diameter small, thus decreasing the demand of optical material used for the lenses of the third objective part.

Both concave mirrors **921**, **922** have spherical mirror surfaces, thus facilitating manufacturing and improving optical performance. If D is a maximum diameter of a lens element of the third objective part in [mm] and c_1 and c_2 are the curvatures of the concave mirrors **921**, **922** in [mm^{-1}], then the following condition is fulfilled by the embodiment of FIG. 21: $1 < D / (|c_1| + |c_2|) \cdot 10^{-4} < 6$. The curvature c is the reciprocal of the curvature radius at the vertex. If this condition is fulfilled, then a good balance between Petzval correction and positive power in the third objective part can be obtained.

FIG. 22 shows a variant of a projection objective **1000** having a general construction similar to that of the embodiment shown in FIG. 4, i.e. having a second objective part **1020** consisting of two concave mirrors **1021**, **1022** and having no refractive optical elements. Reference numerals for similar features/feature groups are similar, increased by 800. The specification is given in tables 22 and 22A. The first, dioptric objective part **1010** for creating the first intermediate image **1003** is subdivided into a first lens group LG11 between object plane and pupil plane **1011** and a second lens group LG12 between the pupil plane and the first intermediate image. The first lens group LG11 starts with the biconvex positive lens **1081**, followed by a negative meniscus lens **1082** having an image side concave surface and a biconvex positive lens **1083**. Particularly high incidence angles occur at the concave exit side of the negative meniscus lens **1082**, which is arranged in a region where the light beam is slightly divergent. The high incidence angles have strong correcting influence. The sequence positive-negative-positive provided by lenses **1081**, **1082**, **1083** has been found to be useful. Therefore, it may be preferable if the first objective part creating the first intermediate image includes at least one concave surface facing the image, which is preferably included in a sequence of positive-negative-positive lenses.

FIG. 23 shows another embodiment of a projection objective **1100** generally designed in accordance of the principles explained in connection with the FIG. 4. The specification is given in tables 23 and 23A. The second objective part **1120** is purely reflective, thus requiring no transparent optical material. Some aspects regarding features facilitating manufacturing will now be explained in connection with this embodiment and with FIG. 24. They may, however, be implemented in other embodiments. Both concave mirrors **1121**, **1122** have similar surfaces, which facilitates manufacturing and improves optical performance. Generally, the shape of a concave mirror has a strong influence on certain aberrations. Particularly, the image curvature (Petzval curvature) is influenced by the vertex curvature of the mirror. If an aspherical mirror surface is used, the basic data of the aspheric surface define certain field dependent aberrations,

particularly the spherical aberration of the pupil, which is proportional to y^4 , where y is the beam height at the concave mirror. Both factors influencing the shape of the mirror surface are deeply rooted in the optical design and are dependent from one another. Particularly, the second factor regarding the type of asphere is strongly influenced by the first factor (basic curvature), since, for example, a strong curvature of the concave mirror will induce strong field dependent aberrations.

Certain crucial factors influencing a good compromise between manufacturability and optical performance of concave mirrors have been identified. One disruptive factor resulting from manufacturing of a concave mirror is the depth up to which a tool must plunge into the material of the mirror substrate in order to create the concave mirror surface. This plunging depth is denoted " p_{max} " in connection with FIG. 24. The maximum sagitta or rising height at the edge of a mirror may be defined as the axial separation of a plane normal to the optical axis and touching the edge of the concave mirror to a plane parallel thereto and touching the vertex of the concave mirror. As schematically shown in FIG. 24, p_{max} is dependent on the curvature radius R of the aspherical mirror surface, and the diameter D of the aspherical mirror. In a first approximation (for aspherical form) p_{max} is given by: $p_{max} = R - (R - D^2 - D^2/4)^{0.5}$. Since the basic shape of the mirror cannot be altered without strongly influencing the optical effect, only the diameter of the mirror surface can be used as a free parameter to influence manufacturability. When considering manufacturing, the grinding of the mirror substrate necessary to define the basic shape of the mirror substrate prior to polishing is particularly addressed. It has been found that it is preferable if the condition $D \leq 1.3R$ is fulfilled and that it may be more preferable if the condition $D \leq 1.2R$ is fulfilled such that also the condition: $p_{max} < 0.22R$ is fulfilled. Manufacturing is also facilitated if the radii of curvature at the vertex of the curved mirror surfaces for two mirrors are as similar as possible. If $R1$ is the vertex radius of curvature of a first mirror and $R2$ is the vertex radius of curvature of the second mirror, it is preferable that the following condition is fulfilled: $0.8 < |R1/R2| < 1.2$. In the embodiment shown in FIG. 23 this condition and the two following conditions are fulfilled: $p_{max} \leq 0.22R$ and $D \leq 1.3R$. It may be sufficient if, in addition to the condition regarding the relation of curvature radii one of the latter conditions is fulfilled.

In the embodiment shown in FIG. 23 the curvatures of the mirrors 1121, 1122 are almost identical (curvature radii differ within less than 1%) and the aspheric shapes are almost identical. The mirrors 1121, 1122 are the only optical elements of the second objective part, thus making this part a catoptric part. The maximum diameter of optical elements of the second objective part 1120 is smaller or almost equal to the maximum diameter of lenses in the third objective part. This facilitates implementation of the axial symmetric projection objective into a wafer stepper or a wafer scanner. Although the aperture stop A is provided in the third objective part, it may also be provided in the first objective part in the vicinity of the pupil surface 1111 thereof.

In FIG. 25 another embodiment of a projection objective 1200 is shown. FIG. 26 shows a detailed view of a section between the object plane 1201 and the second intermediate image 1204 which is the object of a purely refractive objective part 1230 for imaging the second intermediate image onto the image plane 1290 at a reduced scale of about 1:4.

The entire projection objective 1200 designed to image an object disposed in the object plane 1201 onto the image

plane 1202 at a reduced scale consists of three objective parts 1210, 1220, 1230, each designed to image a field plane upstream of the objective part into field plane downstream of the objective part. The first objective part 1210 consists of four consecutive lenses 1211, 1212, 1213 and 1214 followed by the first concave mirror 1221 immediately upstream of the first intermediate image 1203. Therefore, the first objective part is catadioptric. The second objective part 1220 is also catadioptric, including the second concave mirror 1222 immediately downstream of the first intermediate image 1203 and positive lenses 1226, 1227, 1228, 1229, all effective for refocusing the first intermediate image 1203 into the second intermediate image 1204. The third objective part 1230 is purely refractive and includes the freely accessible aperture stop A of the system.

In contrast to the embodiments shown above, only the first intermediate image 1203 is positioned in the intermirror space defined by the concave mirrors 1221, 1222, whereas the second intermediate image 1204 lies outside of this intermirror space. The mirror group defined by the two concave mirrors 1221, 1222 facing each other has a mirror group entry and a mirror group exit. At the mirror group entry positioned geometrically next to the edge of the second mirror 1222 facing the optical axis 1205 radiation coming from the object side enters the intermirror space and at the mirror group exit positioned geometrically next to the edge of the first mirror 1221 facing the optical axis the radiation exits the intermirror space after the reflections on the concave mirrors. It is a characterizing feature of this embodiment that a first pupil surface PS1 of the projection objective lies in the vicinity of the mirror group entry and a second pupil surface PS2 lies in the vicinity of the mirror group exit. In contrast, in most other embodiments, for example those shown in FIGS. 1 to 4, 7 to 14, the entry of the mirror group and the exit of the mirror group are optically close to the intermediate images, which are field surfaces of the projection lens. Also, in the embodiments mentioned above the radiation reflected from the first concave mirror crosses the optical axis prior to impinging on the second concave mirror which effectively leaves the footprints of the radiation on the reflecting surfaces of the concave mirrors at opposite sides of the optical axis. In contrast, in the embodiment shown in FIGS. 25 and 26, first and second concave mirrors 1221, 1222 are disposed on the same side of the optical axis. Due to this difference the optical path within the space defined by the concave mirrors has almost point symmetry with respect to a symmetry point arranged midway between the vertices of the concave mirrors in the embodiments mentioned above, whereas the optical path is almost mirror-symmetric with respect to a mirror plane perpendicular to the optical axis and arranged midway between vertices of the concave mirrors in the embodiment of FIGS. 25, 26.

Optically, embodiments designed essentially according to the principles of the embodiment shown in FIGS. 25, 26 can be advantageous if it is desired to influence field aberrations by the action of lenses close to field planes since one of the field planes between object plane 1201 and image plane 1202, namely the field surface of the second intermediate image 1204 is arranged freely accessible at a distance outside the intermirror space defined by the concave mirrors 1221, 1222. As shown in FIG. 25, two field lenses 1229, 1235 are arranged close to the second intermediate image 1204 immediately upstream (1229) and immediately downstream (1235) of this intermediate image, thus forming a field lens group for aberration correction.

The first and second objective parts 1210, 1220 are effective to form an intermediate image 1204 at a distance

from the mirror group defined by the concave mirrors **1221**, **1222** geometrically behind this mirror group. Since a pupil surface PS2 is arranged in the vicinity of the exit of the mirror group, a group of lenses **1226** to **1228** acting in combination as a Fourier-transforming lens group can be used to position and define the characteristics of the intermediate image **1204**, which then is reimaged on the image plane **1202** by the third objective part **1230**. These properties make the sub-system formed by the first and second objective part **1210**, **1220** useful as a relay system for linking light paths of optical systems ahead and downstream of the relay system together. Due to the action of the concave mirrors **1221**, **1222** of the mirror group this relay system can be designed to have strong influence on the image curvature compensating at least partly the opposite influence of positive lenses upstream and downstream of the mirror group.

FIG. 27 shows a variant of a projection objective **1300** having a general construction similar to that of the embodiment shown in FIG. 4, i.e. having a second, catoptric objective part **1320** consisting of two concave mirrors **1321**, **1322** and having no refractive optical element. Reference numerals for similar features/feature groups are similar as in FIG. 4, increased by 1100. The specification is given in tables 27, 27A.

The first, dioptric objective part **1310** for creating the first intermediate image **1303** has a first lens element **1312** immediately following the object surface **1301**, where the entrance surface of this first lens element is aspheric and convex to the object surface and an aperture stop A is provided in the first objective part in between lens groups each having positive refractive power. The concave mirrors **1321**, **1322** of the catoptric second objective part **1320** each have an aspheric mirror surface. It is a characterizing feature of this design that the aspheric mirror surfaces of mirrors **1321**, **1322** have identical aspheric shape. This allows to use exactly the same optical testing device for measuring the aspheric shape of both concave mirrors in the manufacturing process. As it can be seen from tables 27, 27A the radii of the concave mirrors (describing the basic shape of the mirror surface) and the aspheric constants (describing the aspherical deviation from the basic shape of surfaces **25**, **26**) are identical. In other embodiments the basic shape and the aspheric constants may vary slightly between the two concave mirror. Even in that case significant improvements relating to costs of the manufacturing process can be obtained if the mirror surfaces are shaped similar such that the same measuring optics can be used for testing both mirror surfaces.

The projection objective **1400**, a lens section of which is shown in FIG. 28, has a general construction similar to that on the embodiment shown in FIG. 4. Therefore, reference numerals for similar features/feature groups are similar, increasing by 1200. The specification is given in tables 28 and 28A.

A first, dioptric objective part **1410** including an aperture stop A is designed for creating a first intermediate image **1403**. The second, catoptric (purely reflective) objective part **1420** consists of a first concave mirror **1421** and a second concave mirror **1422** which, in combination, create the second intermediate image **1404** from the first intermediate image **1403**. A dioptric third objective part **1430** is designed for imaging the second intermediate image **1404** onto the image plane **1402**, whereby, during operation, a thin layer of immersion fluid I (water) is transited by the radiation. When optimizing the design, particular care was taken to facilitate optical testing of the aspheric mirror surfaces during mirror

manufacturing. For this purpose, the mirror surface of the first concave mirror **1421** has a parabolic shape (compare table 28A, surface **23**).

The following considerations are provided to facilitate understanding why a parabolic shape of a mirror surface facilitates testing. In a general case, optical testing of an aspherical mirror surface requires use of specifically adapted optical testing system designed to create testing radiation having a distorted wave front which is adapted to the desired aspheric shape of the mirror surface such that the local incidence angles of the test wave onto the aspheric surface are rectangular for each location of the aspheric surface. Optical testing devices using aplanatic optical systems, or compensation systems (K-systems) or computer generated holograms (CGH) or a combination thereof for shaping the distorted wave front are usually employed for this purpose. Since the construction of specifically designed testing optics for each aspherical shape is expensive, alternative methods are desired.

An aspheric mirror having a parabolic shape, in contrast, can be tested with simple testing equipment. For further explanation, it is considered that a purely conical, rotational symmetric surface shape can be described by the following equation:

$$p = \frac{ch^2}{1 + \sqrt{1 - c^2(k+1)h^2}}$$

Here, p is the axial coordinate of a surface point, k is a conical constant, c is the curvature (i.e. the reciprocal (1/r) of radius r) of the surface at the vertex (where the optical axis intersects the mirror surface) and h is the height (measured perpendicular to the optical axis). Using this equation, different conical, rotational symmetric surface shapes can be generated depending on the value of the conical constant k. For example, a spherical shape corresponds to k=0, a value k=-1 describes a parabola, values k<-1 describe a hyperbola and values -1<k<0 describe an elliptic shape. All these shapes have in common that an object point arranged in a specific position (depending on the shape of the surface) will be imaged without aberrations (stigmatic imaging). At least one non-spherical conical mirror may therefore be useful in an embodiment of the invention or in other projection objectives having concave mirrors. Considering the requirements of mirror testing, a parabolic shape (k=-1) is particularly useful since the object point, which will be imaged without spherical aberrations, is positioned at infinity. With other words: light from a test beam or parallel light impinging parallel to the optical axis on a parabolic surface will be focused in one and only one focal point by the parabolic mirror. This is advantageous since no special arrangements for diverging or converging a beam bundle of a test wave are necessary. The test wave has a planar wave front.

A possible testing arrangement is schematically shown in FIG. 29. Here, the parabolic mirror surface **1421** is shown together with the optical axis OA defined by that mirror surface. The testing equipment includes a testing optical system **1460** designed for creating a parallel test light beam parallel to the optical axis OA and incident on the parabolic mirror surface. The testing arrangement further includes a spherical mirror **1470** shaped and arranged with respect to the desired shape of the parabolic mirror **1421** such that the center of curvature **1490** of the spherical mirror **1470** coincides with the focal point of the parabolic mirror. In this

31

arrangement, a test wave **1495** having a plane wave front provided by the optics **1460** and incident on the parabolic mirror surface **1421** is first converged by the parabolic mirror into the focal point **1490** of the parabolic mirror prior to impinging on the spherical mirror **1470**. The spherical mirror **1470** reflects the test wave back along the same path into the test optics **1460**. Deviations in path length between the parabolic mirror and the wave reflected back from the parabolic mirror can be used to characterize the parabolic shape of the parabolic mirror.

The projection objective **1400** is telecentric on the object side and on the image side. One feature contributing to telecentricity on the object side is the particular convex shape of the entrance side of the first lens element (positive meniscus **1412**) immediately following the object plane. Aspheric surfaces on the first two lenses on the object side contribute to telecentricity. The telecentric beam is essentially free of field zone errors on the object and image side, i.e. there is virtually no variation of telecentricity across the object or image field.

In FIGS. **30** to **32** three further embodiments of projection objectives **1500**, **1600** and **1700** having a general construction similar to that shown in FIG. **4** having a catoptric second objective part are shown. Reference numerals for similar features/feature groups are similar, increased by **1300**, **1400**, **1500** respectively. For example, the object and image planes for projection objective **1500** are indicated as object plane **1501** and image plane **1502**, respectively. Also, projection objective **1500** includes mirrors **1521** and **1522**. The object and image planes for projection objective **1600** are indicated as object plane **1601** and image plane **1602**, respectively. Also, projection objective **1600** includes mirrors **1621** and **1622**. The object and image planes for projection objective **1700** are indicated as object plane **1701** and image plane **1702**, respectively. Also, projection objective **1700** includes mirrors **1721** and **1722**. The specifications are given in tables **30**, **30 A**, **31**, **31 A** and **32**, **32 A**. When designing these embodiments, special emphasis was placed on optimization of material consumption and installation space required for the first, dioptric objective part **1510**, **1610**, **1710** serving as a relay system for imaging the object field into the first intermediate image.

As a common feature to all embodiments of FIGS. **30**, **31** and **32** the first objective part has only six lens elements, i.e. transparent optical elements having considerable refractive power. Only positive lenses are used, thereby creating first objective parts with strong converging power in an axially short objective part having relatively small maximum diameter. In all embodiments, a plane parallel plate **1519**, **1619**, **1719** is positioned immediately following the respective first pupil plane **1511**, **1611**, **1711** of the projection objective. One advantage of placing at least one essentially plane parallel plate near a pupil surface is that such plate can be aspherized to correct for aberrations introduced by manufacturing or other effects (correction asphere). Such plate can be ex- changeable. In the embodiment of FIG. **30**, an aperture stop **A** is provided within the first objective part **1510** at the pupil position immediately ahead of the parallel plate **1519**. In the embodiments of FIGS. **31** and **32** the aperture stop is arranged within the third objective part in the region of maximum beam diameter at the third pupil surface **1631**, **1731** respectively. All embodiments mentioned here have only positive lenses between the image side pupil plane and the image plane, where the embodiment in FIG. **30** has five such positive lenses and the other embodiments (FIGS. **31**, **32**) have only four positive lenses between the image side pupil surface and the image plane.

32

A comparative view of the first objective parts of the embodiments in FIGS. **30** to **32** reveals certain relations between the use of aspheric surfaces and the curvature of the entrance surface of the first lens element immediately following the objective plane. In the embodiment of FIG. **30**, first lens element **1512** is a biconvex positive lens having a aspheric entrance surface facing the object plane, where this entrance surface is only slightly curved, with the radius of curvature exceeding **300 mm**. Six aspheric surfaces (indicated by dots) are used. As evident from the rays crossing in the region of the first intermediate image **1503**, coma is one prominent imaging error in the first intermediate image **1503**. This error is compensated by the design of the optical surfaces downstream of the first intermediate image. In contrast, in the embodiment shown in FIG. **31** the aspheric entrance surface of the first lens element (positive meniscus **1612**) has a relatively strong convex curvature having a radius of curvature below **300 mm** ($R \approx 154$ mm in this case). Only four aspheric surfaces are employed in the first objective part **1610**. The aspheric surfaces are adapted to the optical effect of the curved entrance surface such that the first intermediate image **1603** is essentially free of coma. This indicates a trend that a strong convex curvature of the entrance side is useful for obtaining a good quality first intermediate image with a small number of aspherical surfaces. In the first objective part **1710** of the embodiment shown in FIG. **32** an intermediate number of five aspheric surfaces is used in combination with an entrance surface of the first element (biconvex lens **1712**) having moderate curvature (radius of curvature > 300 mm). Providing an entry surface of the projection objective having no curvature (planar surface) or weak curvature (e.g. value of radius of curvature > 500 nm or more) renders the objective relatively insensitive against pressure fluctuations of ambient pressure. As the number of aspheric surfaces is equal or less than the number of positive lenses in the first objective part of all three embodiments it can be seen that compact designs can be obtained when only positive lens elements are used and if a ratio between the number of lenses having refractive power and the number of aspheric surfaces is smaller than **1.6**.

The embodiments of FIG. **30** to **32** show that in the framework of a preferred design having a straight optical axis common to all objective parts and a catoptric second objective part it is possible to design the relay system on the entrance side of the objective (first objective part) with an axial length considerably smaller than the axial length of the third objective part. The axial length (measured between the object surface and the first intermediate image) may be less than **90%** or less than **80%** of the axial length of the third objective part (measured between the second intermediate image and the image plane). This indicates that the design can be used with various different positions of the second (catoptric or catadioptric) objective part between the refractive objective parts.

In the embodiments of FIGS. **30** to **32** the plano-convex lens closest to the image plane, i.e. the last lens of the objective, is made of calcium fluoride. Since this material is less sensitive to radiation induced density variations (particularly compaction) the service life time of the objective maybe increased when compared to objectives having last lenses made of fused silica. However, in immersion objectives designed for operating with water based immersion liquids last lens elements of calcium fluoride are problematic since calcium fluoride is soluble in water. Therefore, the life time of the system may be reduced. Therefore, a protection layer protecting the last lens element from degradation

caused by an aggressive immersion liquid may be useful. Suitable protection layers are described, for example, in U.S. provisional application 60/530,623 filed on Dec. 19, 2003 by the applicant, the disclosure of which is incorporated herein by reference. In the embodiments of FIGS. 30 to 32 a thin plane parallel plate of fused silica having a thickness of 0.3 mm is adhered to the planar exit surface of the plano-convex calcium fluoride lens by wringing. The plane parallel quartz glass plate providing the exit surface of the projection objective can be exchanged, if desired. Exchanging may be desired if the fused silica material is damaged due to high radiation load and/or if contamination and/or scratches on the fused silica protection plate occur.

Using the embodiment of FIG. 32 as an example further characteristic features of projection objectives according to the invention are explained. To this end, a chief ray CR running from an outermost field point (furthest away from the optical axis AX) essentially parallel to the optical axis and intersecting the optical axis at three consecutive pupil surface positions P1, P2, P3, each within one of the imaging objective parts 1710, 1720, 1730, is drawn in bold line to facilitate understanding. The angle included between the optical axis AX and the chief ray CR at each position along the chief ray is denoted "chief ray angle" in the following. The chief ray CR is divergent (chief ray height increasing in light propagation direction) at the position of the first intermediate image 1703. The increasing chief ray height after the first intermediate image corresponds to a negative chief ray intersection length of the first objective part 1710 downstream of the first intermediate image 1703. Here, the "chief ray intersection length" is defined as an axial length between the position of the intermediate image and the intersection point of a tangent to the chief ray CR at the intermediate image. The intersection point is positioned on the object side of the first intermediate image within the first objective part 1710. A negative chief ray intersection length relative to the first intermediate image corresponds to a negative (virtual) exit pupil of the first objective part. In contrast, a convergent chief ray exists at the second intermediate image 1704, corresponding to a positive chief ray intersection length downstream of the second intermediate image, which corresponds to a real exit pupil existing downstream of the second intermediate image. The real exit pupil of the second objective part 1720 relative to the second intermediate image 1704 is therefore positioned outside the third objective part 1730 (real exit pupil) beyond the image plane. The virtual exit pupil of the first objective part 1710 coincides with the real entrance pupil of the second objective part 1720. Given these conditions a projection objective is provided having at least two intermediate images, wherein one imaging objective part (here the catadioptric or catoptric second objective part disposed between a refractive first objective part and a refractive third objective part) performs a real image formation between the first and second intermediate images wherein, in addition, a real entrance pupil is imaged into a real exit pupil. Since there is an accessible pupil surface P1 within the refractive first objective part and another accessible pupil surface P3 within the third objective part projection objectives of this type have two potential positions for placing an aperture stop to effectively define the numerical aperture used in the imaging process. Here, the term "accessible" refers to a potential aperture stop position in a section of an objective part passed only once by the light running through the projection objective.

Further, projection objectives according to preferred embodiments discussed here, have three real pupil surfaces P1, P2, P3 between object plane and image plane, wherein

the maximum chief ray angle in one of these pupil surfaces is smaller than the object side numerical aperture and wherein in addition at least one of the following conditions is fulfilled: (1) The maximum marginal ray height in two of the three pupil surfaces is at most 50% of the maximum marginal ray height in the third pupil surface (here the third pupil surface P3); (2) the maximum chief ray angle in two of the pupil surfaces is at least twice as large as a maximum chief ray angle in the third pupil surface; (3) a maximum chief ray angle in two of the pupil surfaces is at least twice as large as the object side numerical aperture.

In the following, a number of embodiments are shown which are optimized with respect to the aspect of manufacturing and testing the aspheric surfaces used therein. In order to demonstrate one of the problems arising during preparation of aspheric surfaces on lenses FIGS. 33(a) and 33(b) each show an enlarged partial view of a meridional lens section through a conventional objective having a thin positive lens L having an aspheric entrance surface AS. In FIG. 33(a) a characteristic ray R1 running along the periphery of the transmitted beam bundle and a characteristic beam R2 running close to the optical axis of the optical system are shown to demonstrate the optical action of the aspherical lens L. In the conventional system CONV the aspheric surface AS is designed to act as a positive lens for rays passing close to the optical axis and as a negative lens for rays close to the periphery of the light beam (ray R1). In order to obtain this variation of refractive power in meridional direction the aspheric surface has a positive curvature ($C > 0$) in the area around the optical axis and a negative curvature ($C < 0$) in the peripheral region where ray R1 passes. An inflection point IP characterized by a local curvature $C = 0$ is positioned between the convex section (around the optical axis) and the concave section (at the periphery). Although the local change of the sense of curvature obtained this way may be desirable from an optical point of view, inflection points are critical when the surface finishing is considered since a finishing tool (schematically shown as tool T in FIG. 33(b)) having a reasonable diameter for efficient surface polishing may have substantially non-uniform effect in the region around the inflection point. Therefore, sufficient optical quality of aspherical surfaces having inflection points is difficult to obtain.

These problems can be avoided if the aspherical surface has no inflection point. The projection objective 1800 shown in FIG. 34 (specification given in tables 34 and 34A) is designed such that none of the aspherical surfaces has an inflection point.

Another feature of aspheric surfaces identified by inventors as being critical from a manufacturing point of view is explained in connection with FIG. 35. The inventors have found that high optical quality of aspheric surfaces can be obtained if extremal points (minima or maxima) on the surface shape of an aspheric surface outside the optical axis are avoided or, if that is not possible, if extremal points are only used on aspheric surfaces having an essentially flat basic shape. In FIG. 35 the surface shapes of two aspheric surfaces AS1 and AS2 are shown schematically in terms of the function $p(h)$, where p is measured parallel to the optical axis (z -direction) and h is the height of a surface point, where the height corresponds to the radial distance between a surface point and the optical axis. Parameter p , as used here, denotes the axial separation of a plane normal to the optical axis and intersecting the relevant surface point to a plane parallel thereto and touching the vertex V of the optical elements on the optical axis.

35

In that respect, an extremal point on an aspheric surface is characterized by the fact that the first derivative (characterizing the slope of the surface) given by

$$\frac{dp}{dh} = 0$$

and that the second derivative

$$\frac{d^2p}{dh^2} \neq 0$$

(here the second derivative describes the surface curvature). Therefore, the first asphere AS1 in FIG. 35 has a first extremal point EX11 and a second extremal point EX12 having opposite signs of the second derivative, whereas the second asphere AS2 has only one extremal point EX21. In the definitions used here the vertex V of the optical surface (where $h=0$) is excluded from the considerations, since the vertex always is an extremal point of rotational symmetric aspheric surfaces considered here.

In FIG. 35, the surface shape is depicted schematically between the optical axis ($h=0$) and the outer periphery of an area of the surface, which is finished with a tool e.g. by polishing. This finishing area is characterized by a maximum height h_{max} . The maximum area optically used in operation is generally smaller such that the optically utilized radius is characterized by a maximum value $h_{opt} < h_{max}$. The area outside the optically used area between the edge of that area and the edge of the optical component is denoted overrun region OR. This area is normally used for mounting the optical elements. However, during manufacturing the overrun region has to be included into the consideration regarding an optimum surface shape.

In the following it will be explained why extremal points on aspheric surfaces may be critical if optimum surface quality is desired. To this end, a rotary polishing tool T having a reasonable sized diameter is operating in the region of the first extremal point EX11. Depending on the relative dimensions between the "valley" around the extremal point EX11 and the tool T the area at the bottom of the concave valley may not be polished sufficiently enough since the tool "bridges" the critical bottom area most of the time. Therefore, the surface quality in the extremal point region may be different from the surface quality of regions farther away from the critical extremal point. On the other hand, if the extremal point corresponds to a convex "hill" on the aspheric surface, this area may be polished stronger than the surrounding area, which may also lead to irregularities of the surface quality in the extremal point region. These problems can be avoided if the aspheric surface has no extremal points (with the exception of the necessary extremal point at the vertex). Since the tool T will generally extend beyond the maximum optically used area (at h_{opt}) when the peripheral region of the optically used area is treated, it is desirable that extremal points are avoided also in the edge region OR.

On the other hand, aspheric surfaces having extremal points may be desired to obtain certain variations of refractive power of an aspheric surface in meridional direction. It has been found by the inventors that extremal points can be acceptable from a manufacturing point of view if the extremal point is present on an optical surface having an essentially flat basic shape. For example, the aspheric surface may

36

be formed on a flat side of a plano convex or a plano concave lens or on a surface of a plane parallel plate. Preferably, the absolute value of the maximum z-variation (p_{max}) of such surfaces having an extremal point should not exceed 0.5 mm, more preferably should be smaller than 0.25 mm. The optical advantages of extremal points on aspheric surfaces can thus be obtained without significant irregularities in optical surface quality.

In FIG. 36 an embodiment of a projection objective 1900 is shown where all aspheric surfaces are free of extremal points outside the optical axis. The specification is given in tables 36 and 36A. If an aspherical surface with an extremal point should be desired, this should be formed on an optical surface having an essentially flat basic shape, typically having a long radius with $|r| > 2000$ mm.

FIGS. 37 and 38 show embodiments of projection objectives 2000, 2100 designed according to the general construction given in FIG. 4, i.e. having a catoptric (purely reflective) second objective part 2020, 2120, respectively. Reference numerals for similar features/feature groups are similar, increased by 1800, 1900, respectively. The specifications are given in tables 37, 37A and 38, 38A. When designing these embodiments, special emphasis was placed on a balanced design having only few correcting means, such as aspheres, and a moderate number of lens elements. In addition, a balanced distribution of refractive power amongst different parts of the projection objective contributes to a harmonic beam deflection throughout the optical system. The harmonic general construction makes the designs less sensitive against maladjustment of single lens elements or lens groups and facilitates incorporation of manipulators for dynamically influencing the performance of the optical system, e.g. by moving of single lenses or lens groups in axial direction, perpendicular to the optical axis and/or by tilting.

In the embodiment of FIG. 37 only ten aspheric surfaces are used, which, according to the considerations given above, can be manufactured and tested in a relatively cost-effective way. The last optical element (plano-convex lens 2050 immediately ahead of the image plane 2002) is made of fused silica, having a thickness at the edge of the optical used area of about 23 mm. The overall wave front error is reduced to 1.6 mλ. All lenses are made of fused silica, about 60 kg blanc material of fused silica being necessary to make all lenses. In contrast, the plano-convex lens 2150 forming the last element of the embodiment of FIG. 38 is made of calcium fluoride, which material is less prone to radiation induced density variations (compaction and rarefaction). Using 12 aspheric surfaces which can be manufactured with moderate effort it is possible to obtain a performance characterized by a wave front error of 2.1 mλ. An overall blanc mass of about 63 kg fused silica and 1.5 kg calcium fluoride is used for this embodiment.

In FIGS. 39 and 40 two embodiments are shown which are characterized, amongst other features, by the fact that the first objective part imaging the object field into the first intermediate image is a catadioptric objective part including one concave mirror and one additional mirror having a curved mirror surface, where the curved mirror surfaces of the concave mirror and the additional mirror are facing each other such that the first objective part can serve as a relay system in projection objectives of preferred embodiments having one straight common optical axis for all objective parts.

The specification of the projection objective 2200 shown in FIG. 39 is given in table 39 and 39A (aspheric constants). The system is designed for 193 nm for using water ($n=1.436677$) as an immersion fluid. All lenses except the

last image side optical element (plano-convex lens **2260** made of calcium fluoride) are made of fused silica. An image side numerical aperture $NA=1,2$ is obtained at an image field size $26\text{ mm}\cdot 5.5\text{ mm}$ arranged $21,8\text{ mm}$ outside the optical axis. The track length (object image distance) is 1125 mm .

A first, catadioptric objective part **2210** is designed for creating a first intermediate image **2203**. The second, catadioptric objective part **2220** designed for creating the second intermediate image **2204** from the first intermediate image includes a first concave mirror **2221** and a second concave mirror **2222** having concave mirror surfaces facing each other and defining an intermirror space, and a positive meniscus lens **2229** having an aspheric, concave entrance surface immediately downstream of the first intermediate image. A dioptric third objective part **2230** is designed for imaging the second intermediate image onto the image plane **2202**, whereby a thin layer of water (immersion fluid I) is transited by the radiation. An aperture stop A is positioned in the third objective part.

The first objective part **2210** includes, in that optical sequence from the object field, a biconvex positive lens **2211** having a strongly aspheric entrance surface and an aspheric exit surface, a positive meniscus lens **2212** having an aspheric concave entrance surface and a spherical exit surface, and a concave mirror **2213** having an object side concave mirror surface and being arranged eccentrically to the optical axis, but intersecting the optical axis **2205**. The radiation reflected back from the concave mirror transits the positive meniscus **2212** in the opposite direction and mostly on the opposite side of the optical axis compared to the radiation passing between object field and concave mirror **2213**. An additional mirror **2214** with convex mirror surface is provided by an off-axis mirror coating on the image side surface of convex lens **2211**. The radiation passes the positive meniscus **2212** a third time prior to formation of the first intermediate image. Therefore, the lens **2212** is used three times at laterally offset lens regions.

Whereas concave mirror **2213** is positioned optically near a pupil surface, convex mirror **2214** is arranged optically near to the intermediate image **2203**. Therefore, field aberrations and pupil aberrations can be corrected separately by selecting according shapes of the concave and convex mirrors **2213**, **2214**. This allows to adjust the correction status of the first intermediate image **2203** such that residual imaging errors can be compensated by the two objective parts following downstream of the first intermediate image including the catadioptric second objective part **2220**.

The first objective part is designed as an enlarging system having a significant magnification $|\beta_1|>1$. The first intermediate image **2203** is positioned geometrically near the closest edge of concave mirror **2213** outside the intermirror space defined between the concave mirrors **2221** and **2222** of the second objective part, whereby the optical distance between the first intermediate image and the first concave mirror **2221** becomes rather large, whereas the optical distance between the second concave mirror **2222** and the second intermediate image **2204** becomes rather small. Therefore, the sizes of the concave mirrors of the second objective part differ significantly, the optically used area of the first concave mirror being about twice as large as the corresponding area on the second concave mirror. Both concave mirrors **2221** and **2222** are positioned outside the optical axis such that the optical axis does not intersect the optically used mirror surfaces. Since the concave mirrors are positioned at different positions with regard to the ratio between the ray heights of principal ray and marginal ray, the correcting

effects of the concave mirrors on different imaging errors can be distributed between the two catadioptric objective parts **2210** and **2220**.

The projection objective **2300** shown in FIG. **40** is designed as a "solid immersion lens" having a finite image side working distance in the order of the design wavelength λ of the system (193 nm) or fractions thereof (e.g. $\lambda/2$ or $\lambda/4$ or below). Evanescent fields exiting from the exit surface of the last lens can be used for imaging. The system is adapted for optical near field lithography. Reference is made to German patent application DE 10332112.8 filed on Jul. 9, 2003 by the applicant, where preferred conditions for optical near field lithography are specified. No liquid immersion fluid is necessary in this case for obtaining an image side numerical aperture $NA>1$. In the embodiment $NA=1.05$ for a image field size $22\text{ mm}\cdot 4.5\text{ mm}$, where the image field is arranged 39 mm off-axis. The overall reduction ratio is 1:4, the track length is 1294.4 mm . In this design, all lenses including the last, image side plano-convex lens **2360** are made of fused silica. The specification is given in tables 40 and 40A (aspheric constants).

The first, catadioptric objective part **2310** designed for creating the first intermediate image **2303** from the object field on an enlarged scale includes, in that sequence along the optical path, a biconvex positive lens **2311** having an aspheric entrance surface and a spherical exit surface, a concave mirror **2312**, having an object side mirror surface, a convex mirror **2313** having slightly curved convex mirror surface facing the concave mirror and being formed by a mirror coating on an elevated section of the image side lens surface of lens **2311**, a bispherical positive meniscus lens **2314** having a concave entry side, and a biconvex positive lens **2315** having a strongly aspheric exit surface positioned in the immediate vicinity of the first intermediate image **2303**.

The second, catadioptric objective part **2320** picks up the first intermediate image **2303** and forms the second intermediate image **2304** located geometrically within an intermirror space defined by the first concave mirror **2321** and the second concave mirror **2322** of the second objective part. The second objective part further includes negative meniscus lenses **2325**, **2326** each positioned immediately ahead of the mirror surface of an associated concave mirror **2321** and **2322**, respectively. A strong correcting effect on longitudinal chromatic aberration (CHL) can be obtained this way. A biconvex positive lens **2328** having an object side aspheric surface and an image side spherical surface extends across the entire diameter of the projection objective between the first and second concave mirrors **2321**, **2322** and is passed three times by the radiation, once between the first intermediate image and the first concave mirror, a second time between the first and the second concave mirrors **2321**, **2322** and a third time between the second concave mirror **2322** and the second intermediate image **2304**.

In this embodiment, all three concave mirrors **2312**, **2321**, **2322** are positioned optically remote from the pupil surface of the projection objective. Also, the almost flat convex mirror **2313** is positioned clearly outside the first pupil surface P1. The design allows to distribute the correcting effects of catadioptric objective parts between the first and the second objective part.

The invention allows to manufacture catadioptric projection objectives which, in many respects of practical implementation into a projection exposure apparatus, have similar properties to conventional refractive projection objectives, whereby a change over between refractive systems and catadioptric systems is greatly facilitated. Firstly, the inven-

tion allows to built catadioptric projection objectives having one straight (unfolded) optical axis. Further, an object field disposed on one side of the optical axis may be imaged into an image field disposed on the opposite side of the optical axis, i.e. the imaging is performed with “negative magnification”. Thirdly, the objectives can be designed to have isotropic magnification. Here, the term “isotropic magnification” refers to an image formation without “image flip”, i.e. without a change of chirality between object field and image field. With other words, features on the reticle described in a right handed coordinate system can be described in a similar right handed coordinate system in the image. The negative isotropic magnification is present in both x- and y-directions perpendicular to the optical axis. This allows to use the same type of reticles also used for imaging with refractive projection objectives. These features facilitate implementation of catadioptric projection objectives according to the invention in conventional exposure apparatus designed for refractive projection objectives since no major reconstructions are required, for example, at the reticle- and wafer-stages. Also, reticles designed for use with refractive projection objectives can in principle also be used with catadioptric projection objectives according to the invention. Considerable cost savings for the end user can be obtained this way.

As mentioned earlier, the invention allows to built catadioptric projection objectives with high numerical aperture, particularly allowing immersion lithography at numerical apertures $NA > 1$, that can be built with relatively small amounts of optical material. The potential for small material consumption is demonstrated in the following considering parameters describing the fact that particularly compact projection objectives can be manufactured.

Generally, the dimensions of projection objectives tend to increase dramatically as the image side numerical aperture NA is increased. Empirically it has been found that the maximum lens diameter D_{max} tends to increase stronger than linear with increase of NA according to $D_{max} \sim NA^k$, where $k > 1$. A value $k=2$ is an approximation used for the purpose of this application. Further, it has been found that the maximum lens diameter D_{max} increases in proportion to the image field size (represented by the image field height Y). A linear dependency is assumed for the purpose of the application. Based on these considerations a first compactness parameter COMP1 is defined as:

$$COMP1 = D_{max} / (Y \cdot NA^2).$$

It is evident that, for given values of image field height and numerical aperture, the first compaction parameter COMP1 should be as small as possible if a compact design is desired.

Considering the overall material consumption necessary for providing a projection objective, the absolute number of lenses, N_L is also relevant. Typically, systems with a smaller number of lenses are preferred to systems with larger numbers of lenses. Therefore, a second compactness parameter COMP2 is defined as follows:

$$COMP2 = COMP1 \cdot N_L$$

Again, small values for COMP2 are indicative of compact optical systems.

Further, projection objectives according to the invention have at least three objective parts for imaging an entry side field plane into an optically conjugate exit side field plane, where the imaging objective parts are concatenated at intermediate images. Typically, the number of lenses and the overall material necessary to build an projection objective

will increase the higher the number N_{op} of imaging objective parts of the optical system is. It is desirable to keep the average number of lenses per objective part, N_L/N_{OP} , as small as possible. Therefore, a third compactness parameter COMP3 is defined as follows:

$$COMP3 = COMP1 \cdot N_L / N_{OP}$$

Again, projection objectives with low optical material consumption will be characterized by small values of COMP3.

Table 41 summarizes the values necessary to calculate the compactness parameters COMP1, COMP2, COMP3 and the respective values for these parameters for each of the systems presented with a specification table (the table number (corresponding to the same number of a figure) is given in column 1 of table 41). Therefore, in order to obtain a compact catadioptric projection objective having at least one concave mirror and at least three imaging objective parts (i.e. at least two intermediate images) at least one of the following conditions should be observed:

$$COMP1 < 11$$

Preferably $COMP1 < 10,8$, more preferably $COMP1 < 10,4$, even more preferably $COMP1 < 10$ should be observed.

$$COMP2 < 300$$

Preferably $COMP2 < 280$, more preferably $COMP2 < 250$, even more preferably $COMP2 < 230$ should be observed

$$COMP3 < 100$$

Preferably $COMP3 < 90$, more preferably $COMP3 < 80$, even more preferably $COMP3 < 75$ should be observed.

Table 41 shows that preferred embodiments according to the invention generally observe at least one of these conditions indicating that compact designs with moderate material consumption are obtained according to the design rules laid out in this specification.

If desired, various types of filling gases can be used to fill the empty spaces between the optical elements of the projection objectives. For example, air or nitrogen or helium can be used as filling gas depending on desired properties of the embodiment.

Favorable embodiments may be characterized by one or more of the following conditions. The first objective part is preferably designed as an enlarging system, preferably having a magnification β_1 in the range $1 < |\beta_1| < 2.5$. This ensures low NA at the first intermediate image and helps to avoid vignetting problems. $|\beta_1|$ may be 1:1 or may be slightly smaller, e.g. $0.8 \leq |\beta_1| \leq 1$. The second objective part is preferably designed as a system having near to unit magnification, i.e. almost no magnification or reduction. Particularly, the second objective part may be designed as a system having a magnification β_2 in the range $0.4 < |\beta_2| < 1.5$, more preferably in the range $0.8 < |\beta_2| < 1.25$ or in the range $0.9 < |\beta_2| < 1.1$. The third objective part preferably has a reducing magnification $|\beta_3| < 1$. The entire projection objective has a magnification β where $\beta = \beta_1 \cdot \beta_2 \cdot \beta_3$. The second intermediate image may have a size larger than the image size.

Preferably, both the first intermediate image and the second intermediate image are located geometrically within the intermirror space between the first concave mirror and the second concave mirror. They may be located geometrically in a middle region centered around the midpoint between the two concave mirrors within the intermirror space between the first concave mirror and the second concave mirror, wherein the middle region extends in a

space having an axial extension $\leq 90\%$ of an axial distance between the vertices of the curvature surfaces of the first and second concave mirror.

If d is the distance on the optical axis between the two concave mirrors, $d1$ is the distance on the optical axis between the first intermediate image and the first concave mirror and $d2$ is the distance on the optical axis between the second concave mirror and the second intermediate image, then the relations: $0.5 d/2 < d1 < 1.5 d/2$ and $0.5 d/2 < d2 < 1.5 d/2$ are preferably satisfied. The distances mentioned above are to be measured along the optical axis, which may be folded. Preferably, a chief ray of the most off axial field point intersects the optical axis in the same described region between $d/4$ and $3d/4$ between the two concave mirrors in the vicinity of the location of the first intermediate image. Pupil positions are then remote from mirrors.

It has been found useful to design the optical system such that at least one intermediate image, preferably all intermediate images are positioned such that there exists a finite minimum distance between the intermediate image and the next optical surface, which is a mirror surface in most embodiments. If a finite minimum distance is maintained it can be avoided that contaminations or faults on or in the optical surface are imaged sharply into the image plane such that the desired imaging of a pattern is disturbed. Preferably, the finite distance is selected depending on the numerical aperture of the radiation at the intermediate image such that a sub-aperture (footprint of a particular field point) of the radiation on the optical surface next to the intermediate image has a minimum diameter of at least 3 mm or at least 5 mm or at least 10 mm or at least 15 mm. It is obvious from the figures and tables that these conditions are easily met by most or all embodiments in relation to the distance between an intermediate image within the intermirror space and the mirror surface arranged optically nearest to the intermediate image. Embodiments having intermediate images arranged in the middle region between the concave mirrors are particularly well-natured in this respect.

All transparent optical components of the embodiments described above, with a possible exception at the last image side lens, which may be of calcium fluoride, are fabricated from the same material, namely fused silica (SiO_2). However, other materials, in particular, crystalline alkaline earth metal fluoride materials, that are transparent at the working wavelength may also be used. At least one second material may also be employed in order to, for example, assist correction for chromatic aberration, if necessary. Of course, the benefits of the invention may also be utilized in the case of systems intended for use at other wavelengths, for example, at 248 nm or 157 nm.

Some or all conditions are met by some or all embodiments described above.

It is to be understood that all systems described above may be complete systems for forming a real image (e.g. on a wafer) from a real object. However, the systems may be used as partial systems of larger systems. For example, the "object" for a system mentioned above may be an image formed by an imaging system (relay system) upstream of the object plane. Likewise, the image formed by a system mentioned above may be used as the object for a system (relay system) downstream of the image plane.

The above description of the preferred embodiments has been given by way of example. From the disclosure given, those skilled in the art will not only understand the present invention and its attendant advantages, but will also find apparent various changes and modifications to the structures and methods disclosed. It is sought, therefore, to cover all changes and modifications as fall within the spirit and scope of the invention, as defined by the appended claims, and equivalents thereof.

The contents of all the claims is made part of this description by reference.

TABLE 4

J 205				
Surface	Radius	Thickness	Material	1/2 Diam.
1	151.647118	39.665046	SIO2	86.120
2	-1368.552447	69.197177		85.246
3	158.992783	15.145647	SIO2	75.907
4	206.923841	38.570349		73.675
5	97.678872	40.014335	SIO2	69.070
6	-5437.460665	6.811056		64.924
7	138.801509	16.000000	SIO2	53.028
8	573.226631	49.296968		47.448
9	-57.862177	14.263643	SIO2	47.630
10	-84.936107	112.509668		57.274
11	-413.250477	39.459821	SIO2	106.087
12	-160.648303	5.882304		109.942
13	797.277933	34.177152	SIO2	115.560
14	-430.752073	244.699332		115.661
15	-199.609067	-204.699112	REFL	134.925
16	157.344690	246.319295	REFL	109.289
17	862.084499	22.994398	SIO2	70.571
18	-419.719089	18.726730		69.767
19	-150.816336	15.000000	SIO2	67.991
20	131.971848	26.143914		70.182
21	-1567.196375	19.813697	SIO2	72.656
22	-217.593380	44.615314		76.740
23	-2829.863046	39.782748	SIO2	103.845
24	-203.824432	1.000000		107.411
25	524.684787	25.000000	SIO2	114.960
26	902.564365	1.000000		115.451
27	530.781146	38.825378	SIO2	116.178
28	-473.210631	1.000000		116.066
29	0.000000	0.000000		113.556
30	322.948582	29.038119	SIO2	113.791
31	-2580.799702	1.000000		113.022
32	512.569763	30.174661	SIO2	110.876
33	-677.235877	1.000000		109.014
34	106.347684	68.066974	SIO2	90.295
35	-1474.944139	0.999719		77.627
36	54.296611	42.467148	CAF2	45.513
37	0.000000	3.000000	H2O	20.998

TABLE 4A

Aspherical Constants						
SRF						
K	2	3	8	12	15	16
	0	0	0	0	0	0
C1	3.477033e-08	-6.813990e-09	3.966411e-07	4.439638e-09	1.447452e-08	4.549402e-08
C2	-4.731536e-13	-8.621629e-12	-4.007014e-12	1.686758e-13	2.261476e-13	-5.067161e-12
C3	2.796504e-17	-2.762099e-16	7.436146e-15	8.011815e-19	2.580774e-18	2.777252e-16
C4	-6.649516e-22	-9.615951e-21	1.520683e-18	9.201114e-22	1.377485e-22	-3.138154e-20
C5	-2.829603e-25	-5.726076e-24	-9.949722e-22	-4.382820e-26	-3.426657e-27	2.350745e-24
C6	1.815473e-29	3.251913e-28	7.293926e-25	1.782591e-30	1.279942e-31	-7.599030e-29

SRF						
K	17	19	22	30	33	35
	0	0	0	0	0	0
C1	1.523352e-07	1.162948e-07	-1.982157e-08	1.201912e-08	1.147736e-08	9.136462e-08
C2	-5.763168e-12	-6.089203e-13	-5.382822e-13	-1.705175e-13	4.202468e-13	-5.545932e-13
C3	7.475933e-17	-1.025185e-16	1.200748e-17	-8.926277e-17	-1.260714e-17	1.560631e-16
C4	6.617515e-20	2.192456e-20	-2.867314e-21	-4.435922e-21	-2.591704e-21	-3.601282e-20
C5	-2.264827e-24	-5.792211e-25	1.105789e-25	8.175482e-25	4.606100e-26	8.986671e-25
C6	-1.064596e-28	5.642674e-28	-3.023003e-31	-2.371799e-29	9.707119e-30	3.847941e-29

25

TABLE 7

J 206				
Surface	Radius	Thickness	Material	½ Diam.
1	0.000000	0.000000		76.473
2	196.748623	27.263207	SIO2	81.548
3	1380.478547	27.173549		81.569
4	148.118896	29.558580	SIO2	83.220
5	985.952509	45.383760		81.731
6	587.017766	26.742601	SIO2	74.752
7	-268.687626	5.952675		73.075
8	121.069967	20.000000	SIO2	59.416
9	338.972294	15.471207		55.151
10	123.398576	16.000000	SIO2	42.222
11	493.239196	38.514952		36.268
12	-56.743953	79.995013	SIO2	40.070
13	-98.465204	60.825433		74.618
14	-3097.977653	27.304241	SIO2	102.327
15	-295.526762	3.782338		104.658
16	271.693311	37.763865	SIO2	112.015
17	-3936.289483	25.000000		112.208
18	162.629416	202.628857		112.852
19	-195.636303	-202.628857	REFL	119.680
20	162.629416	202.628857	REFL	104.093
21	-195.636303	44.391294		76.907
22	-1229.055417	33.250147	SIO2	83.109

TABLE 7-continued

J 206				
Surface	Radius	Thickness	Material	½ Diam.
23	-160.024467	37.552215		84.448
24	-246.047659	15.000000	SIO2	74.951
25	134.897718	28.252914		72.042
26	-768.808515	15.000000	SIO2	73.163
27	-355.461110	71.356200		76.177
28	-3425.435334	32.788842	SIO2	102.647
29	-255.172254	10.903212		105.332
30	695.872359	30.470261	SIO2	110.205
31	-625.346253	9.352817		110.381
32	0.000000	-8.352817		108.884
33	329.990101	40.669818	SIO2	110.434
34	-427.546014	1.000000		110.052
35	158.678466	45.978153	SIO2	102.564
36	378.976619	1.000000		95.391
37	108.606008	71.612816	SIO2	81.775
38	526.305326	1.000000		54.478
39	52.236898	36.413852	CAF2	39.598
40	0.000000	3.000000	H2O	19.842

TABLE 7A

Aspherical Constants					
SRF					
K	4	11	15	18	19
	0	0	0	0	0
C1	-6.330577e-08	3.463909e-07	1.324809e-08	-7.037790e-09	2.310646e-08
C2	-3.872322e-12	-2.533709e-11	2.103578e-13	-2.219032e-13	3.623856e-13
C3	1.663761e-17	3.527218e-14	3.059213e-18	-7.410203e-18	5.711204e-18
C4	-2.340311e-20	-2.199769e-17	-5.028780e-23	-1.155705e-22	8.453421e-23
C5	1.375334e-24	-1.507925e-21	1.624941e-26	-8.984707e-27	1.508061e-27
C6	-1.682943e-29	5.496658e-24	-6.281302e-31	-1.590542e-31	1.239941e-31

TABLE 7A-continued

Aspherical Constants						
SRF						
K	22 0	24 0	27 0	34 0	36 0	38 0
C1	6.335247e-08	3.536885e-08	8.583557e-08	2.169817e-08	-1.524001e-08	1.877887e-07
C2	-1.090600e-11	9.732363e-12	3.629209e-12	-5.404878e-13	1.625696e-12	1.445239e-11
C3	2.432505e-16	-1.879646e-16	-8.012301e-17	5.551093e-17	-3.076521e-16	1.060456e-16
C4	-1.490760e-21	1.841476e-20	5.223547e-20	-2.305595e-21	8.708326e-21	3.470869e-19
C5	1.908731e-24	-2.885890e-24	-9.160836e-24	4.260803e-26	4.665020e-25	-6.424228e-23
C6	-1.282225e-28	2.916860e-28	1.028273e-27	-9.442220e-32	-2.136828e-29	1.397331e-26

15

TABLE 8

J 201					20
Surface	Radius	Thickness	Material	½ Diam.	
1	0.000000	0.000000		77.084	
2	144.715774	34.413396	SIO2	85.539	
3	1168.820838	42.714222		84.636	
4	137.626538	26.913912	SIO2	78.160	
5	231.768696	25.969904		74.133	
6	-256.723584	9.491982	SIO2	73.679	
7	-300.099619	24.637606		73.830	
8	95.378233	35.795212	SIO2	66.319	
9	2978.156744	6.137057		62.554	
10	113.175934	18.340535	SIO2	50.838	
11	791.566883	42.223464		45.085	
12	-57.334745	47.676082	SIO2	42.772	
13	-104.057645	85.668623		64.264	
14	-747.828120	23.558823	SIO2	98.262	
15	-237.780029	11.502675		100.729	
16	466.711415	38.824036	SIO2	109.480	
17	-377.473708	39.986102		109.791	
18	160.832778	201.116223		111.102	
19	-190.162844	-201.116223	REFL	125.335	
20	160.832778	201.116223	REFL	106.939	

TABLE 8-continued

J 201				
Surface	Radius	Thickness	Material	½ Diam.
21	-190.162844	40.087040		74.503
22	-429.676099	17.543012	SIO2	77.631
23	-222.069915	45.151970		78.588
24	-438.919401	16.685064	SIO2	75.545
25	125.893773	22.634903		73.362
26	706.231560	15.535140	SIO2	74.562
27	-483.323705	69.793709		76.473
28	-1219.864506	31.389217	SIO2	101.495
29	-226.588128	6.763552		104.174
30	443.080071	40.992305	SIO2	110.047
31	-556.882957	4.990520		109.849
32	0.000000	-3.144971		107.701
33	274.803577	29.023782	SIO2	108.934
34	-6968.358008	0.969032		108.499
35	213.748670	46.817088	SIO2	106.084
36	-8609.746220	0.945349		101.542
37	114.821261	64.641285	SIO2	84.961
38	-4598.248046	0.926317		66.788
39	53.647792	40.301900	CAF2	42.988
40	0.000000	3.000000	H2O	20.327

TABLE 8A

Aspherical Constants					
SRF					
K	4 0	11 0	15 0	18 0	19 0
C1	-5.141395e-08	4.483031e-07	1.313620e-08	-7.985633e-09	2.017668e-08
C2	-5.556822e-12	-9.959839e-12	3.644835e-13	-2.642498e-13	3.361249e-13
C3	-2.754499e-16	5.082134e-15	5.949608e-18	-6.856089e-18	4.310554e-18
C4	-1.253113e-20	2.578467e-18	5.732895e-22	-5.142965e-22	1.686493e-22
C5	-4.228497e-24	-3.461879e-21	-2.284813e-26	1.912150e-26	-3.551936e-27
C6	2.490029e-28	1.628794e-24	8.340263e-31	-1.470786e-30	2.057764e-31

TABLE 8A-continued

Aspherical Constants						
SRF						
K	22 0	24 0	27 0	34 0	36 0	38 0
C1	4.549402e-08	1.523352e-07	1.162948e-07	-1.982157e-08	1.201912e-08	1.148008e-07
C2	-5.067161e-12	-5.763168e-12	-6.089203e-13	-5.382822e-13	-1.705175e-13	-5.056506e-13
C3	2.777252e-16	7.475933e-17	-1.025185e-16	1.200748e-17	-8.926277e-17	1.189381e-16
C4	-3.138154e-20	6.617515e-20	2.192456e-20	-2.867314e-21	-4.435922e-21	-1.274117e-20
C5	2.350745e-24	-2.264827e-24	-5.792211e-25	1.105789e-25	8.175482e-25	-3.981271e-24
C6	-7.599030e-29	-1.064596e-28	5.642674e-28	-3.023003e-31	-2.371799e-29	3.798968e-28

TABLE 16

NA = 1.2, β = 0.25					
Field	a	b	c		
	26	5	4.75		
WL 193.3 nm SILUV 1.56049116 CAFUV 1.50110592 H2OV 1.4368					
Surface	Radius	Thickness	Material	½Diam.	Type
0	0.000000000	31.999475127	AIR	65.000	
1	133.894287787	14.995217082	SILUV	84.778	
2	127.681095498	25.597460396	AIR	82.945	
3	402.041163143	34.247197246	SILUV	84.808	
4	-292.795248488	0.996612226	AIR	85.527	
5	-865.792789804	19.686989978	SILUV	84.845	
6	-194.300017249	0.997731584	AIR	84.746	
7	166.499926718	34.205033740	SILUV	81.167	
8	-3411.356708300	0.997606594	AIR	78.713	
9	108.528463069	16.234112594	SILUV	67.657	
10	101.654206518	13.668730583	AIR	60.671	
11	161.992336120	14.997158671	SILUV	58.598	
12	2789.766305580	83.396846659	AIR	54.555	
13	-51.475183292	14.997760255	SILUV	49.489	
14	-64.480378016	0.998543606	AIR	60.882	
15	-523.449669764	57.729408261	SILUV	91.022	
16	-124.018124564	0.995673329	AIR	97.756	
17	213.269322132	24.422343766	SILUV	111.322	
18	368.130596294	326.268973067	AIR	110.123	
19	-161.615015336	14.998434538	SILUV	131.765	
20	-312.345980956	31.430358591	AIR	153.714	
21	-214.602996812	-31.430358591	AIR	155.986	REFL
22	-312.345980956	-14.998434538	SILUV	149.921	
23	-161.615015336	-238.077915164	AIR	116.301	
24	149.287132498	-14.998202246	SILUV	103.169	
25	317.538289321	-33.202694396	AIR	133.495	
26	186.422421298	33.202694396	AIR	137.843	REFL
27	317.538289321	14.998202246	SILUV	136.305	
28	149.287132498	324.504871734	AIR	116.434	
29	304.025895186	51.634530337	SILUV	102.695	
30	-321.237280055	36.471806645	AIR	101.284	
31	-141.718556476	14.999755253	SILUV	84.799	
32	104.217593104	30.610688625	AIR	74.074	
33	581.141203674	15.015591714	SILUV	75.850	
34	-637.266899243	22.019923725	AIR	78.058	
35	-222.755672262	20.582750922	SILUV	80.475	
36	-149.492790226	0.999906680	AIR	84.782	
37	260.619344057	25.604090348	SILUV	101.752	
38	1033.029187190	30.684011762	AIR	102.212	
39	181.295872049	62.489568781	SILUV	109.856	
40	-319.175759184	1.032697080	AIR	108.616	
41	0.000000000	24.649355928	AIR	99.183	
42	241.322246262	26.360109939	SILUV	88.680	
43	-555.614152728	2.010445644	AIR	85.697	
44	77.526002487	41.372376482	SILUV	67.268	
45	494.197664171	0.978420324	AIR	60.833	
46	46.187199269	35.625423750	CAFUV	39.405	

TABLE 16-continued

47	0.000000000	2.999559725	H2OV	20.942
48	0.000000000	0.000000000	AIR	16.250

TABLE 16A

Aspherical Constants				
Surface	K	C1	C2	C3
3	0.00000000e+000	-8.36067621e-008	2.12798795e-011	-1.45207564e-015
6	0.00000000e+000	7.69835587e-008	2.07985891e-012	1.16482389e-016
7	0.00000000e+000	1.36850714e-007	-9.44752603e-012	-1.50977238e-016
12	0.00000000e+000	7.53715484e-007	-6.61209701e-011	4.22074183e-015
16	0.00000000e+000	-5.85261742e-008	7.70941737e-013	-1.40836094e-016
29	0.00000000e+000	9.56507182e-008	-2.16638529e-012	-1.23753850e-017
31	0.00000000e+000	1.85417093e-007	-2.24667567e-012	6.93769095e-017
34	0.00000000e+000	1.66095759e-007	2.43350203e-012	8.88822140e-017
39	0.00000000e+000	-3.25790615e-009	-2.00206347e-012	4.31870304e-017
42	0.00000000e+000	-5.33787564e-008	2.40117270e-012	3.20136118e-016
43	0.00000000e+000	1.13532739e-007	-5.93286761e-012	1.32296454e-015
45	0.00000000e+000	8.97031378e-008	2.47066509e-011	-2.77876411e-016

Surface	C4	C5	C6
3	7.63154357e-020	2.95348560e-024	-3.46561258e-028
6	-4.80737790e-021	5.59439946e-024	-1.29197249e-028
7	-5.84681939e-020	7.86623559e-024	-7.24516725e-028
12	-8.02992365e-019	-7.38686026e-022	1.22771230e-025
16	6.45911985e-021	-3.82872278e-025	4.17640461e-031
29	2.58232933e-022	-6.80943505e-025	3.02935682e-029
31	6.79498891e-020	-6.82812342e-024	2.20970580e-028
34	2.60945386e-020	-3.60666201e-024	5.36227764e-028
39	-2.48544823e-021	5.50166118e-026	-3.31463292e-031
42	9.55299044e-021	-9.27935397e-024	8.13460411e-028
43	-1.88960302e-019	1.04299856e-023	1.69382125e-028
45	-7.08589002e-019	1.20774587e-022	-7.67132589e-027

TABLE 17

NA = 1.2, β = 0.25			
Field	a	b	c
	26	5	4.75

WL 193.3 nm SILUV 1.56049116 CAFUV 1.50110592 H2OV 1.438				
Surface	Radius	Thickness	Material	½Diam. Type
0	0.000000000	31.997721704	AIR	65.000
1	579.464506139	20.317824521	SILUV	74.592
2	-577.479988552	0.999475036	AIR	75.821
3	2572.370914820	28.040565960	SILUV	76.612
4	243.390586919	11.985977074	AIR	79.119
5	500.676303821	43.989139515	SILUV	80.893
6	-155.064044118	21.184157632	AIR	82.707
7	1381.321630200	18.191562266	SILUV	75.159
8	-393.944847792	0.998449340	AIR	74.340
9	87.946501567	40.892320851	SILUV	65.550
10	99.239178252	25.553101192	AIR	52.382
11	209.138140913	15.063951314	SILUV	45.950
12	-601.200979555	66.005892131	AIR	42.845
13	-55.332841330	14.999477956	SILUV	50.547
14	-72.577526567	1.163693447	AIR	62.349
15	-346.873498438	34.446292165	SILUV	80.990
16	-150.420697383	2.645359711	AIR	86.680
17	611.326207207	44.474569849	SILUV	99.391
18	-228.818841769	265.128541011	AIR	100.925
19	-190.727371287	15.000448317	SILUV	108.586
20	-237.320724749	14.700965847	AIR	118.645
21	-194.872786703	-14.700965847	AIR	120.611 REFL

TABLE 17-continued

22	-237.320724749	-15.000448317	SILUV	116.199
23	-190.727371287	-195.428248584	AIR	100.830
24	190.727371287	-15.000448317	SILUV	104.448
25	237.320724749	-14.700965847	AIR	120.847
26	194.872786703	14.700965847	AIR	124.569 REFL
27	237.320724749	15.000448317	SILUV	122.685
28	190.727371287	266.167203345	AIR	111.392
29	315.808627637	45.375871773	SILUV	95.944
30	-367.849317765	64.350407265	AIR	94.229
31	-123.002265506	14.998717744	SILUV	70.954
32	113.714722161	32.318363032	AIR	68.389
33	-990.749351417	21.237444356	SILUV	71.838
34	-292.571717802	35.154029607	AIR	78.053
35	-18220.224013700	40.604404749	SILUV	103.420
36	-201.028020704	1.097799815	AIR	107.104
37	366.725287540	37.745092677	SILUV	119.548
38	-961.362776974	0.999856805	AIR	119.749
39	338.337923773	38.019811036	SILUV	118.590
40	-1026.771599840	-1.410077329	AIR	117.118
41	0.000000000	12.743520660	AIR	115.541
42	280.022380007	19.482737236	SILUV	110.210
43	1517.149279230	1.197846646	AIR	108.733
44	719.327066326	32.079810786	SILUV	107.695
45	-474.571764529	2.724748590	AIR	105.913
46	89.479992014	48.063302904	SILUV	75.467
47	364.001398221	2.359587817	AIR	64.121
48	52.126874613	39.040570663	CAFUV	42.333
49	0.000000000	2.999196815	H2OV	20.183
50	0.000000000	0.000000000	AIR	16.250

TABLE 17A

Aspherical Constants				
Surface	K	C1	C2	C3
6	0.00000000e+000	-1.15035308e-009	6.18896918e-013	-4.28285081e-016
7	0.00000000e+000	-1.72652480e-008	-3.70258486e-014	-1.25882856e-015
12	0.00000000e+000	3.77928406e-007	1.46912216e-011	2.33469503e-015
16	0.00000000e+000	-6.96857458e-008	-2.84037647e-012	2.05085140e-017
19	0.00000000e+000	-2.08753341e-008	-3.76211193e-013	-1.18384407e-017
23	0.00000000e+000	-2.08753341e-008	-3.76211193e-013	-1.18384407e-017
24	0.00000000e+000	2.08753341e-008	3.76211193e-013	1.18384407e-017
28	0.00000000e+000	2.08753341e-008	3.76211193e-013	1.18384407e-017
29	0.00000000e+000	7.78624253e-008	-5.29798090e-013	3.91516327e-018
31	0.00000000e+000	4.28231334e-008	1.84180203e-011	2.69407820e-017
34	0.00000000e+000	1.06085944e-007	5.27851125e-012	1.44463148e-016
42	0.00000000e+000	-4.37269250e-008	-1.57509731e-012	8.65198568e-019
45	0.00000000e+000	-9.15770551e-009	-5.99358306e-014	-2.27293408e-016
47	0.00000000e+000	6.18789306e-008	2.40430885e-011	-5.44722370e-015
Surface	C4	C5	C6	
6	4.88391880e-021	3.14518856e-024	-2.05304958e-028	
7	1.13451047e-019	-1.35997879e-023	1.27061565e-027	
12	-6.54678942e-018	3.46881149e-021	-5.35085168e-025	
16	-1.26467485e-020	4.46161412e-025	-4.85676248e-029	
19	-1.88960591e-021	1.06203954e-025	-5.85068978e-030	
23	-1.88960591e-021	1.06203954e-025	-5.85068978e-030	
24	1.88960591e-021	-1.06203954e-025	5.85068978e-030	
28	1.88960591e-021	-1.06203954e-025	5.85068978e-030	
29	-1.04724068e-020	6.70919693e-025	-2.39519868e-029	
31	9.37813713e-020	-2.33189316e-023	9.94588095e-028	
34	1.26175655e-020	-1.49657869e-024	2.33032636e-028	
42	-3.26636505e-021	2.73829199e-025	2.06805365e-030	
45	2.70272716e-020	-1.30446854e-024	3.13007511e-029	
47	7.58602437e-019	-6.94042849e-023	2.94089737e-027	

TABLE 19

NA = 1.2, β = 0.25					
Field	a	b	c		
	26	4.5	4.75		
WL 193.3 nm SILUV 1.56049116 CAFUV 1.50110592 H2OV 1.4368					
Surface	Radius	Thickness	Material	1/2Diam.	Type
0	0.000000000	31.999270282	AIR	65.000	
1	161.244041962	14.998636035	SILUV	82.320	
2	200.129661131	4.944776020	AIR	81.953	
3	138.221863276	14.998396795	SILUV	85.474	
4	156.496992798	50.903040817	AIR	83.945	
5	-173.315527687	16.279875172	SILUV	84.438	
6	-142.013268785	1.000634788	AIR	87.160	
7	15501.649257700	32.544206280	SILUV	87.713	
8	-158.845141838	0.999631849	AIR	89.436	
9	91.597097363	67.410407247	SILUV	79.148	
10	107.035143103	13.851994874	AIR	57.324	
11	213.854334447	15.987143481	SILUV	54.995	
12	-484.417010515	72.563101783	AIR	51.059	
13	-54.334592127	14.997747797	SILUV	49.752	
14	-68.072352503	0.998695446	AIR	60.236	
15	-601.365655277	24.817582741	SILUV	80.082	
16	-242.182339653	0.995504271	AIR	83.903	
17	920.810751329	35.748197919	SILUV	91.860	
18	-213.159366146	55.021374074	AIR	93.280	
19	246.612722217	14.997702082	SILUV	89.716	
20	222.836314969	195.136099792	AIR	86.935	
21	-235.528678750	14.998801176	SILUV	123.772	
22	-252.575360887	16.051090308	AIR	131.942	
23	-208.057958857	-16.051090308	AIR	133.654	REFL
24	-252.575360887	-14.998801176	SILUV	128.868	
25	-235.528678750	-195.136099792	AIR	114.227	
26	222.836314969	-14.997702082	SILUV	106.191	
27	246.612722217	-15.024807366	AIR	119.874	
28	190.206428127	15.024807366	AIR	122.140	REFL
29	246.612722217	14.997702082	SILUV	120.950	
30	222.836314969	195.136099792	AIR	111.677	
31	-235.528678750	14.998801176	SILUV	83.094	
32	-252.575360887	56.045936568	AIR	86.484	
33	370.979663784	47.033021034	SILUV	99.224	
34	-371.323272898	62.417517206	AIR	97.788	
35	-121.118365852	14.999357361	SILUV	74.709	
36	120.855315866	33.365820253	AIR	72.995	
37	20779.359547400	24.110061836	SILUV	77.786	
38	-269.244136428	16.073764059	AIR	83.845	
39	-236.048531861	28.909364173	SILUV	86.677	
40	-161.907128190	8.188854525	AIR	94.856	
41	842.230350676	46.587674654	SILUV	117.052	
42	-262.240874081	3.490322496	AIR	119.226	
43	374.311200849	50.091253523	SILUV	123.021	
44	-396.081152439	-8.144186891	AIR	122.235	
45	0.000000000	9.143428258	AIR	118.495	
46	290.815269675	69.706490303	SILUV	113.550	
47	-465.439617778	0.998821533	AIR	106.611	
48	84.362795313	48.231691787	SILUV	73.577	
49	220.065022009	0.997153094	AIR	60.089	
50	51.630320906	38.562324381	CAFUV	42.677	
51	0.000000000	2.998760762	H2OV	20.925	
52	0.000000000	0.000000000	AIR	16.250	

TABLE 19A

Aspherical Constants				
Surface	K	C1	C2	C3
6	0.00000000e+000	5.22123357e-008	8.58887551e-013	-4.54164064e-016
7	0.00000000e+000	-5.20183796e-008	-4.57191269e-012	-4.91479340e-016
12	0.00000000e+000	3.52517346e-007	2.85321977e-011	9.33189645e-017

TABLE 19A-continued

Aspherical Constants				
16	0.0000000e+000	-1.19054499e-007	-6.17053971e-013	8.29918331e-017
20	0.0000000e+000	2.35880706e-008	1.10625664e-014	1.52718231e-017
21	0.0000000e+000	-1.93271271e-008	-1.21191457e-014	-9.08764375e-018
25	0.0000000e+000	-1.93271271e-008	-1.21191457e-014	-9.08764375e-018
26	0.0000000e+000	2.35880706e-008	1.10625664e-014	1.52718231e-017
30	0.0000000e+000	2.35880706e-008	1.10625664e-014	1.52718231e-017
31	0.0000000e+000	-1.93271271e-008	-1.21191457e-014	-9.08764375e-018
33	0.0000000e+000	1.34282593e-007	-1.85430392e-012	-4.26524890e-017
35	0.0000000e+000	-2.95757718e-009	1.59584067e-011	-3.65004253e-016
38	0.0000000e+000	1.44418264e-007	4.50598204e-012	-8.46201050e-019
46	0.0000000e+000	-1.03608598e-008	-1.39868032e-012	-2.06257372e-017
47	0.0000000e+000	-2.35449031e-008	6.28466297e-017	5.46615500e-020
49	0.0000000e+000	1.18378675e-007	2.25652288e-011	-6.89451988e-015

Surface	C4	C5	C6
6	1.80084384e-021	-1.27939182e-025	9.21858288e-029
7	3.70354199e-020	-2.59625588e-024	-9.35416883e-031
12	1.46216022e-018	1.35490801e-022	-4.07118530e-026
16	-1.92366012e-020	1.44946211e-024	-4.85055808e-029
20	4.13946988e-022	-1.55058201e-026	1.20806176e-030
21	-5.34976868e-023	-1.13872365e-027	-9.05434146e-032
25	-5.34976868e-023	-1.13872365e-027	-9.05434146e-032
26	4.13946988e-022	-1.55058201e-026	1.20806176e-030
30	4.13946988e-022	-1.55058201e-026	1.20806176e-030
31	-5.34976868e-023	-1.13872365e-027	-9.05434146e-032
33	2.28325758e-022	-3.90557972e-026	-2.65242779e-030
35	2.40761278e-019	-3.76176852e-023	1.70246167e-027
38	-5.19608735e-021	-2.54791026e-025	1.06081720e-028
46	-1.69652628e-021	1.44074754e-025	2.91395857e-030
47	5.71824030e-021	-4.38179150e-025	1.61431061e-029
49	1.27155044e-018	-1.75366514e-022	1.10664062e-026

TABLE 20

NA = 1.2, β = 0.25			
Field	a	b	c
26		4.5	4.75

WL 193.3 nm SILUV 1.56049116 CAFUV 1.50110592 H2OV 1.4368					
Surface	Radius	Thickness	Material	½Diam.	Type
0	0.000000000	44.536474494	AIR	64.000	
1	-145.614238159	20.028968251	SILUV	71.569	
2	-106.712344272	3.165042254	AIR	75.720	
3	-126.799930892	14.997327707	SILUV	77.371	
4	-400.529009983	24.938975486	AIR	89.386	
5	-153.978050679	32.035367034	SILUV	91.679	
6	-113.485754514	3.962209737	AIR	96.767	
7	481.661051100	51.626847869	SILUV	109.810	
8	-218.069217303	0.986417498	AIR	110.501	
9	95.461306806	78.518887093	SILUV	88.224	
10	197.024903934	20.433893299	AIR	65.510	
11	245.480984290	15.389927680	SILUV	50.234	
12	208.931069399	52.005350380	AIR	39.571	
13	-51.537539329	25.208829578	SILUV	43.896	
14	-67.256773583	31.133045864	AIR	59.014	
15	-353.059395237	33.742142302	SILUV	97.721	
16	-152.100516860	1.776048462	AIR	102.828	
17	-246.044785191	45.384512544	SILUV	109.125	
18	-136.487212093	39.988466465	AIR	113.661	
19	0.000000000	201.398483236	AIR	114.931	
20	-233.811577421	14.982820253	SILUV	137.713	
21	-370.567496646	37.810813405	AIR	153.233	
22	-216.552824900	-37.810813405	AIR	155.425	REFL
23	-370.567496646	-14.982820253	SILUV	147.967	
24	-233.811577421	-201.398483236	AIR	120.238	
25	168.695670563	201.398483236	AIR	106.748	REFL

TABLE 20-continued

26	-233.811577421	14.982820253	SILUV	76.924
27	-370.567496646	37.810813405	AIR	81.451
28	0.000000000	40.022296005	AIR	92.209
29	241.209000864	59.448832101	SILUV	108.950
30	-367.385238353	16.411120649	AIR	108.057
31	357.895873274	15.315252659	SILUV	93.192
32	94.401040596	38.563342544	AIR	77.588
33	442.579628511	14.989394891	SILUV	78.610
34	12021.837327700	28.864129981	AIR	79.433
35	-191.074651244	21.063184315	SILUV	81.221
36	-155.506376055	9.229041305	AIR	86.157
37	185.464309512	44.606063412	SILUV	101.263
38	-1150.340708410	31.620758000	AIR	100.270
39	0.000000000	-0.000000330	AIR	92.899
40	134.597113443	29.097516432	SILUV	92.514
41	296.937234549	3.458534424	AIR	90.494
42	150.878027709	36.379168022	SILUV	87.171
43	-494.554249982	0.979230496	AIR	84.334
44	65.631220570	30.011852752	SILUV	57.267
45	126.706468270	0.934188028	AIR	49.586
46	43.426322889	31.956384174	CAFUV	36.843
47	0.000000000	2.999915964	H2OV	20.807
48	0.000000000	0.000000000	AIR	16.001

TABLE 20A

Aspherical Constants				
Surface	K	C1	C2	C3
1	0.00000000e+000	-1.87990337e-008	-7.06178066e-012	-1.25139326e-015
6	0.00000000e+000	2.08430698e-009	3.65727833e-013	1.43149385e-018
7	0.00000000e+000	1.33126997e-008	-2.47997131e-012	3.62223701e-017
12	0.00000000e+000	6.92559246e-007	1.01811160e-010	4.16533262e-015
16	0.00000000e+000	1.26266812e-008	-7.60497043e-013	5.26322462e-017
20	0.00000000e+000	-2.84981575e-008	5.16388350e-013	-2.39579817e-017
24	0.00000000e+000	-2.84981575e-008	5.16388350e-013	-2.39579817e-017
26	0.00000000e+000	-2.84981575e-008	5.16388350e-013	-2.39579817e-017
29	0.00000000e+000	1.10496506e-007	-6.42644915e-012	2.43910073e-016
31	0.00000000e+000	-8.94334736e-008	5.51621746e-012	2.64317734e-016
34	0.00000000e+000	7.27650226e-008	5.05452869e-012	2.12206759e-016
42	0.00000000e+000	-5.69019750e-008	-3.78079018e-012	-3.58536429e-016
43	0.00000000e+000	3.85631053e-008	-1.96032685e-012	-4.18174469e-016
45	0.00000000e+000	1.32980535e-007	6.98357216e-011	-9.96688046e-015
Surface	C4	C5	C6	
1	1.04002349e-019	1.61613724e-024	-2.08243603e-028	
6	3.84125705e-021	-4.35918853e-025	5.89812982e-029	
7	-3.52780013e-022	1.86263171e-025	-7.15398794e-030	
12	2.76714831e-017	-1.56122873e-020	5.24368076e-024	
16	1.50861183e-021	2.14471673e-025	2.66224210e-030	
20	3.35275866e-022	-8.50016423e-028	-1.97442790e-031	
24	3.35275866e-022	-8.50016423e-028	-1.97442790e-031	
26	3.35275866e-022	-8.50016423e-028	-1.97442790e-031	
29	-1.98759724e-020	8.00452148e-025	-9.31628471e-030	
31	3.20019743e-020	-4.26422117e-024	1.50940276e-028	
34	5.08829476e-020	-5.03622460e-024	7.39342220e-028	
42	-4.25536201e-020	2.42006208e-024	1.84293028e-028	
43	9.23637376e-020	-8.60875665e-024	4.05098414e-028	
45	-3.10084571e-019	1.88265675e-022	-4.40640742e-026	

TABLE 21

NA = 1.2, β = 0.25				
Field	a	b	c	
	26	4.5	4.75	
WL 193.3 nm SILUV 1.56049116 CAFUV 1.50110592 H2OV 1.4368				
Surface	Radius	Thickness	Material	½Diam. Type
0	0.000000000	31.999392757	AIR	64.675
1	149.202932404	20.120662646	SILUV	82.837
2	233.357095260	1.010428853	AIR	82.195
3	172.529012606	14.999455624	SILUV	83.021
4	153.116811658	37.462782355	AIR	80.924
5	-385.292133909	24.003915576	SILUV	81.802
6	-189.041850576	1.014246919	AIR	84.223
7	-1521.447544300	27.529894754	SILUV	83.808
8	-150.691487200	0.999361796	AIR	85.384
9	89.238407847	56.953687562	SILUV	75.993
10	101.329520927	13.713067990	AIR	58.085
11	176.794820361	18.039991299	SILUV	55.978
12	-447.950790449	73.129977874	AIR	52.127
13	-57.595257960	16.299538518	SILUV	50.436
14	-83.036630542	0.999811850	AIR	64.360
15	-2287.430407510	44.210083628	SILUV	86.772
16	-147.632600397	0.998596167	AIR	92.132
17	-352.966686998	32.886671205	SILUV	97.464
18	-153.824954969	271.807415024	AIR	100.038
19	-238.525982305	14.998824247	SILUV	122.669
20	-315.714610405	19.998064817	AIR	131.899
21	-202.650261219	-19.998064817	AIR	131.917 REFL
22	-315.714610405	-14.998824247	SILUV	131.852
23	-238.525982305	-196.811186275	AIR	112.411
24	207.441141965	-14.998504935	SILUV	107.771
25	268.178120713	-19.998469851	AIR	124.363
26	193.196124575	19.998469851	AIR	127.679 REFL
27	268.178120713	14.998504935	SILUV	125.948
28	207.441141965	271.807924190	AIR	114.576
29	325.701461380	38.709870586	SILUV	92.964
30	-885.381927410	59.476563453	AIR	90.975
31	-123.867242183	18.110373017	SILUV	74.226
32	126.359054159	30.087671186	AIR	73.733
33	-16392.865249200	31.626040348	SILUV	77.090
34	-299.592698534	15.292623049	AIR	86.158
35	-296.842399050	24.895495087	SILUV	89.777
36	-163.748333285	8.131594074	AIR	94.529
37	675.259743609	47.908987883	SILUV	116.712
38	-263.915255162	1.054743285	AIR	118.641
39	356.010681144	47.536295502	SILUV	120.712
40	-435.299476405	3.543672029	AIR	119.727
41	0.000000000	10.346485925	AIR	112.597
42	256.262375445	67.382487780	SILUV	107.047
43	-454.037284452	0.998990981	AIR	99.451
44	84.434680547	36.424585989	SILUV	70.101
45	207.490725651	0.997139930	AIR	62.005
46	50.112836179	41.301883710	CAFUV	43.313
47	0.000000000	2.999011124	H2OV	20.878
48	0.000000000	0.000000000	AIR	16.169

TABLE 21A

Aspherical Constants				
Surface	K	C1	C2	C3
6	0.00000000e+000	5.47357338e-008	1.50925239e-012	-1.14128005e-015
7	0.00000000e+000	-5.65236098e-008	-4.45251739e-012	-1.12368170e-015
12	0.00000000e+000	3.75669258e-007	2.00493160e-011	-1.57617930e-015
16	0.00000000e+000	-2.97247128e-008	-1.16246607e-013	1.91525676e-016
19	0.00000000e+000	-1.79930163e-008	-1.81456294e-014	-6.42956161e-018
23	0.00000000e+000	-1.79930163e-008	-1.81456294e-014	-6.42956161e-018
24	0.00000000e+000	1.41712563e-008	1.42766536e-013	5.35849443e-018

TABLE 21A-continued

Aspherical Constants				
28	0.00000000e+000	1.41712563e-008	1.42766536e-013	5.35849443e-018
29	0.00000000e+000	1.42833387e-007	3.55808937e-014	-1.23227147e-017
31	0.00000000e+000	-1.51349602e-008	1.62092054e-011	-4.43234287e-016
34	0.00000000e+000	1.39181850e-007	3.36145772e-012	-4.99179521e-017
42	0.00000000e+000	-4.24593271e-009	-1.84016360e-012	-2.09008867e-017
43	0.00000000e+000	-1.75350671e-008	1.70435017e-014	1.85876255e-020
45	0.00000000e+000	4.03560215e-008	2.57831806e-011	-6.32742355e-015

Surface	C4	C5	C6
6	2.03745939e-022	-1.46491288e-024	3.18476009e-028
7	7.05334891e-020	-6.42608755e-024	4.64154513e-029
12	2.00775938e-018	-1.81218495e-022	1.59512857e-028
16	-5.42330199e-021	4.84113906e-025	-1.50564943e-030
19	-1.72138657e-022	4.34933124e-027	-2.46030547e-031
23	-1.72138657e-022	4.34933124e-027	-2.46030547e-031
24	5.30493751e-022	-2.04437497e-026	1.09297996e-030
28	5.30493751e-022	-2.04437497e-026	1.09297996e-030
29	1.26320560e-021	1.99476309e-025	-1.46884711e-029
31	2.01248512e-019	-3.73070267e-023	1.98749982e-027
34	-8.18195448e-021	4.05698527e-025	4.11589492e-029
42	-2.89704097e-021	1.96863338e-025	6.53807102e-030
43	6.37197338e-021	-5.19573140e-025	2.34597624e-029
45	9.55984243e-019	-1.13622236e-022	6.56644929e-027

TABLE 22

Surface	Radius	Thickness	Material	½Diam.	Type
0	0.000000000	31.993696817	AIR	65.000	
1	0.000000000	-0.006216437	AIR	75.178	
2	173.245898492	28.849219645	SILUV	80.701	
3	-1901.645842520	1.159056366	AIR	81.186	
4	139.958280577	17.383993593	SILUV	82.800	
5	114.690720801	65.798932682	AIR	78.012	
6	177.803002075	54.744184912	SILUV	88.979	
7	-204.801382425	0.997356478	AIR	88.078	
8	89.450127459	21.884550473	SILUV	62.734	
9	143.066432170	15.678153833	AIR	57.180	
10	-13433.891703300	15.000276693	SILUV	54.058	
11	-8853.549440170	13.872934681	AIR	46.493	
12	0.000000000	0.000000000	AIR	37.955	
13	0.000000000	61.755398574	AIR	38.009	
14	-66.760883146	14.994014816	SILUV	54.182	
15	-72.012316741	23.617101147	AIR	60.909	
16	-63.807677134	21.572901785	SILUV	62.830	
17	-76.257505928	1.720678480	AIR	75.095	
18	1299.192911670	55.482510512	SILUV	104.240	
19	-148.321651349	39.989348698	AIR	106.312	
20	0.000000000	232.380264110	AIR	95.929	
21	-201.575622280	-232.380264110	AIR	121.585	REFL
22	199.702239038	232.380264110	AIR	118.875	REFL
23	0.000000000	39.986853275	AIR	91.439	
24	162.499205332	44.748459237	SILUV	93.810	
25	-2036.857320830	1.012661476	AIR	91.212	
26	141.444403824	15.471017813	SILUV	77.784	
27	167.499214725	41.441314042	AIR	72.833	
28	-106.505215697	14.992253348	SILUV	70.530	
29	98.946616742	44.625025386	AIR	64.458	
30	-139.301063148	14.998444853	SILUV	66.132	
31	-339.669887909	0.997145626	AIR	79.298	
32	1356.020956420	23.905236106	SILUV	86.623	
33	-340.109054698	5.477848077	AIR	90.957	
34	472.296115575	52.138063579	SILUV	108.763	
35	-222.876812950	8.808100307	AIR	112.258	
36	2053.528638090	24.342755161	SILUV	119.824	
37	-621.581254067	1.014456714	AIR	120.910	
38	210.455448779	43.312493694	SILUV	124.650	
39	-1489.901649750	5.393215295	AIR	124.077	
40	210.646045010	47.972124824	SILUV	119.142	
41	-627.180734089	0.998977914	AIR	117.607	
42	97.515291800	53.409662718	SILUV	82.565	

TABLE 22-continued

Surface	Radius	Thickness	Material	1/2Diam. Type
43	469.577208920	0.998603706	AIR	69.163
44	58.393704585	42.102914517	CAFUV	46.689
45	0.000000000	3.001333990	H2OV	20.956

TABLE 22A

Aspherical Constants					
Surface 2		Surface 5		Surface 6	
K	0.0000	K	0.0000	K	0.0000
C1	-4.85507054e-008	C1	4.63982284e-008	C1	7.93368538e-008
C2	8.30450606e-013	C2	-4.36308368e-016	C2	-3.49340213e-012
C3	-6.5835562e-016	C3	-4.56700150e-016	C3	-3.72450023e-016
C4	6.07754089e-020	C4	1.41944231e-020	C4	-1.50853577e-020
C5	-4.30736726e-024	C5	-2.58792066e-024	C5	4.35840155e-024
C6	9.97068342e-029	C6	2.91613493e-032	C6	-1.74914218e-028
C7	0.00000000e+000	C7	0.00000000e+000	C7	0.00000000e+000
C8	0.00000000e+000	C8	0.00000000e+000	C8	0.00000000e+000
C9	0.00000000e+000	C9	0.00000000e+000	C9	0.00000000e+000
Surface 11		Surface 19		Surface 21	
K	0.0000	K	0.0000	K	0.0000
C1	3.21277393e-007	C1	1.27016347e-008	C1	1.00526801e-008
C2	2.34047891e-012	C2	4.09192710e-013	C2	1.78849410e-013
C3	1.48915392e-014	C3	2.48214285e-017	C3	2.48862104e-018
C4	-1.12960188e-017	C4	9.66053244e-022	C4	9.77481750e-023
C5	3.70333100e-021	C5	1.60329104e-027	C5	-3.23746064e-028
C6	-4.63366043e-025	C6	2.07652380e-030	C6	6.28188299e-032
C7	0.00000000e+000	C7	0.00000000e+000	C7	0.00000000e+000
C8	0.00000000e+000	C8	0.00000000e+000	C8	0.00000000e+000
C9	0.00000000e+000	C9	0.00000000e+000	C9	0.00000000e+000
Surface 22		Surface 24		Surface 28	
K	0.0000	K	0.0000	K	0.0000
C1	-8.36189868e-009	C1	3.26436925e-008	C1	1.73452145e-007
C2	-1.86708153e-013	C2	9.95492740e-013	C2	9.62198511e-012
C3	-3.35782535e-018	C3	3.47886760e-017	C3	8.33010916e-016
C4	-6.14811355e-023	C4	6.60667009e-021	C4	-4.89738667e-020
C5	-6.72093224e-028	C5	-3.90366799e-025	C5	-2.08149618e-023
C6	-5.98449275e-032	C6	4.03156525e-029	C6	2.57941116e-027
C7	0.00000000e+000	C7	0.00000000e+000	C7	0.00000000e+000
C8	0.00000000e+000	C8	0.00000000e+000	C8	0.00000000e+000
C9	0.00000000e+000	C9	0.00000000e+000	C9	0.00000000e+000
Surface 31		Surface 34		Surface 38	
K	0.0000	K	0.0000	K	0.0000
C1	1.28849399e-007	C1	-2.57944586e-008	C1	-1.91471943e-008
C2	4.99181087e-012	C2	7.33527637e-013	C2	-1.34589512e-012
C3	5.65181638e-017	C3	-5.33079171e-018	C3	3.11852582e-017
C4	2.64289484e-020	C4	-8.21688122e-022	C4	-2.35897615e-021
C5	-3.15869403e-024	C5	-2.94478649e-026	C5	6.73415544e-026
C6	-3.04781776e-029	C6	2.23217522e-030	C6	1.62707757e-030
C7	0.00000000e+000	C7	0.00000000e+000	C7	0.00000000e+000
C8	0.00000000e+000	C8	0.00000000e+000	C8	0.00000000e+000
C9	0.00000000e+000	C9	0.00000000e+000	C9	0.00000000e+000
Surface 40		Surface 41		Surface 43	
K	0.0000	K	0.0000	K	0.0000
C1	-6.30346424e-008	C1	-2.41682461e-008	C1	1.25460964e-007
C2	-4.64729134e-013	C2	1.18102559e-013	C2	7.10922055e-012
C3	3.22359222e-017	C3	-1.34037856e-016	C3	-1.61078694e-015
C4	2.89305419e-023	C4	1.79602212e-020	C4	1.49634597e-019
C5	-2.15332629e-026	C5	-8.86179442e-025	C5	-1.71885653e-023
C6	8.39177392e-031	C6	1.89592509e-029	C6	1.04621563e-027
C7	0.00000000e+000	C7	0.00000000e+000	C7	0.00000000e+000
C8	0.00000000e+000	C8	0.00000000e+000	C8	0.00000000e+000
C9	0.00000000e+000	C9	0.00000000e+000	C9	0.00000000e+000

TABLE 23

WL	193.3 nm	193.4 nm	193.2 nm
SILUV	1.560491	1.560332	1.560650
CAFUV	1.501106	1.501010	1.501202
H2OV	1.436800	1.436800	1.436800

Ymax = 64.675 mm; NA = 1.2

Surface	Radius	Thickness	Material	1/2Diam.	Type
0	0.000000000	32.343320391	AIR	64.675	
1	0.000000000	0.319194773	AIR	74.840	
2	165.502154849	22.393605178	SILUV	81.725	
3	427.564472229	78.042155049	AIR	81.442	
4	362.770694637	28.092832019	SILUV	88.424	
5	-418.998032701	0.953143564	AIR	88.789	
6	108.458706796	42.211528711	SILUV	85.410	
7	309.813567338	43.976162585	AIR	80.542	
8	440.563406352	17.425727560	SILUV	60.495	
9	-278.343745406	54.725816031	AIR	56.963	
10	-65.973394609	15.012675322	SILUV	50.057	
11	-89.483928231	44.616098218	AIR	59.618	
12	-164.547135387	29.271100213	SILUV	82.247	
13	-110.100956635	0.995307980	AIR	86.942	
14	-467.051029385	33.374516855	SILUV	94.291	
15	-156.421752282	39.987151223	AIR	96.378	
16	0.000000000	229.883694545	AIR	89.855	
17	-196.922423263	-229.883694545	AIR	115.021	REFL
18	196.894790764	229.883694545	AIR	115.024	REFL
19	0.000000000	40.005209742	AIR	89.120	
20	158.312187294	42.217660752	SILUV	95.332	
21	2467.131056460	70.144222480	AIR	92.913	
22	-160.335654972	14.992560808	SILUV	73.410	
23	116.412074936	38.531709122	AIR	69.984	
24	-250.712291671	18.369318291	SILUV	71.881	
25	-300.079780156	31.051013458	AIR	80.817	
26	5705.510103480	24.334610155	SILUV	107.710	
27	-458.981124329	14.563800138	AIR	111.524	
28	946.448274166	62.249192106	SILUV	126.621	
29	-192.486608755	1.015402218	AIR	129.650	
30	-4079.043797180	15.732935333	SILUV	130.993	
31	-1100.089935780	14.595769901	AIR	131.283	
32	0.000000000	0.000000000	AIR	130.790	
33	0.000000000	-13.603116119	AIR	131.340	
34	220.445900864	51.281950308	SILUV	133.878	
35	-1597.683074300	5.271684397	AIR	133.124	
36	215.527385603	15.522171709	SILUV	124.678	
37	314.221642044	4.657196014	AIR	121.589	
38	305.812344416	42.963421749	SILUV	120.269	
39	-771.778612980	0.996840378	AIR	117.157	
40	109.741348234	43.192990855	SILUV	84.698	
41	708.633799886	6.161060319	AIR	76.900	
42	66.404779509	39.130193750	CAFUV	46.929	
43	0.000000000	2.999814914	H2OV	20.723	
44	0.000000000	0.000000000	AIR	16.171	

TABLE 23A

Aspherical Constants					
Surface 3		Surface 4		Surface 9	
K	0.0000	K	0.0000	K	0.0000
C1	5.16435696e-008	C1	9.50247881e-010	C1	1.24922845e-007
C2	-3.34181067e-012	C2	-3.73319015e-012	C2	1.54187542e-011
C3	3.14093710e-017	C3	-6.51837734e-017	C3	-3.69685941e-016
C4	-3.87421162e-022	C4	-7.93160821e-021	C4	1.37785719e-018
C5	-8.61200118e-027	C5	9.00091591e-025	C5	-3.60351270e-022
C6	-1.47089082e-029	C6	-1.92340271e-028	C6	2.85480659e-026
C7	0.00000000e+000	C7	0.00000000e+000	C7	0.00000000e+000
C8	0.00000000e+000	C8	0.00000000e+000	C8	0.00000000e+000
C9	0.00000000e+000	C9	0.00000000e+000	C9	0.00000000e+000
Surface 13		Surface 17		Surface 18	
K	0.0000	K	0.0000	K	0.0000
C1	1.45134700e-009	C1	9.25585261e-009	C1	-8.29620456e-009
C2	1.24926632e-014	C2	1.67052938e-013	C2	-1.78159419e-013

TABLE 23A-continued

Aspherical Constants					
C3	8.37553299e-018	C3	2.68611580e-018	C3	-3.07128696e-018
C4	2.49716672e-021	C4	1.04166910e-022	C4	-8.08505340e-023
C5	-2.66380030e-025	C5	-1.70724722e-027	C5	2.33488811e-028
C6	2.61815898e-029	C6	1.10260829e-031	C6	-8.31087015e-032
C7	0.00000000e+000	C7	0.00000000e+000	C7	0.00000000e+000
C8	0.00000000e+000	C8	0.00000000e+000	C8	0.00000000e+000
C9	0.00000000e+000	C9	0.00000000e+000	C9	0.00000000e+000
Surface 20		Surface 22		Surface 25	
K	0.0000	K	0.0000	K	0.0000
C1	1.71573479e-008	C1	-9.04880266e-009	C1	1.11732794e-007
C2	5.87191967e-013	C2	3.31829223e-012	C2	5.01044308e-012
C3	3.53602344e-017	C3	-7.82564703e-017	C3	1.82247821e-016
C4	3.89188764e-021	C4	7.87650776e-020	C4	2.99282347e-021
C5	-2.56256746e-025	C5	-7.94502597e-024	C5	-2.06723334e-024
C6	2.81528130e-029	C6	2.40943558e-027	C6	2.32093750e-029
C7	0.00000000e+000	C7	0.00000000e+000	C7	0.00000000e+000
C8	0.00000000e+000	C8	0.00000000e+000	C8	0.00000000e+000
C9	0.00000000e+000	C9	0.00000000e+000	C9	0.00000000e+000
Surface 28		Surface 34		Surface 36	
K	0.0000	K	0.0000	K	0.0000
C1	-2.42933057e-008	C1	-8.91439687e-009	C1	-5.63334250e-008
C2	3.07041360e-014	C2	-7.33160527e-013	C2	-3.26907281e-013
C3	7.41003764e-018	C3	-4.83885006e-018	C3	9.72642980e-017
C4	-5.26534391e-022	C4	-2.37515306e-022	C4	4.30118073e-021
C5	1.17630052e-026	C5	2.33792040e-026	C5	-5.03894259e-025
C6	-1.17982545e-031	C6	-2.27854885e-032	C6	1.42974281e-029
C7	0.00000000e+000	C7	0.00000000e+000	C7	0.00000000e+000
C8	0.00000000e+000	C8	0.00000000e+000	C8	0.00000000e+000
C9	0.00000000e+000	C9	0.00000000e+000	C9	0.00000000e+000
Surface 39		Surface 41			
K	0.0000	K	0.0000		
C1	-1.21454753e-008	C1	4.06678857e-008		
C2	1.19750305e-012	C2	3.94505025e-012		
C3	-6.39990660e-017	C3	-2.03790398e-016		
C4	4.10753453e-021	C4	2.07246865e-020		
C5	-1.17680773e-025	C5	-3.19577553e-024		
C6	4.05203512e-030	C6	2.12601962e-028		
C7	0.00000000e+000	C7	0.00000000e+000		
C8	0.00000000e+000	C8	0.00000000e+000		
C9	0.00000000e+000	C9	0.00000000e+000		

TABLE 27

Sur- face	(EM28)				1/2 Diameter
	Radius	Asphere	Thickness	Material	
1	0.000000		-0.028411	LUFTV193	76.078
2	148.374584	AS	30.141343	SiO2V	82.524
3	2980.684122		2.731918	N2VP950	82.907
4	177.363525		46.196958	SiO2V	84.542
5	765.980001	AS	27.096346	N2VP950	80.837
6	2666.335118		22.841301	SiO2V	73.658
7	-291.755432	AS	0.990907	N2VP950	70.887
8	230.707988		26.508915	SiO2V	65.013
9	-298.406132		21.906961	N2VP950	61.389
10	-112.314548		10.039397	SiO2V	45.510
11	-118.846218		2.540087	N2VP950	43.187
12	0.000000		0.000000	N2VP950	35.411
13	0.000000		18.000000	N2VP950	35.411
14	0.000000		10.013160	SiO2V	46.508
15	0.000000		0.991399	N2VP950	50.085
16	237.566392		20.385633	SiO2V	54.619
17	-476.646043		28.746587	N2VP950	57.184
18	-81.332740		10.129443	SiO2V	59.250
19	-86.414601		0.995700	N2VP950	63.535
20	-2069.485733	AS	30.115541	SiO2V	71.732
21	-141.210644		0.983397	N2VP950	74.255
22	962.252932	AS	9.980083	SiO2V	74.793

TABLE 27-continued

Sur- face	(EM28)					1/2 Diameter
	Radius	Asphere	Thickness	Material		
23	819.084531		36.977869	N2VP950	75.040	
24	0.000000		198.944441	N2VP950	77.850	
25	-167.595461	AS	-198.944441	REFL	139.680	
26	167.595461	AS	198.944441	REFL	111.811	
27	0.000000		36.992449	N2VP950	110.123	
28	268.305681		49.624605	SiO2V	123.343	
29	-828.322347	AS	47.027120	N2VP950	122.544	
30	327.800199		39.684648	SiO2V	108.912	
31	-1269.440044	AS	0.995014	N2VP950	106.029	
32	331.950903		9.989996	SiO2V	93.089	
33	95.290319		49.810064	N2VP950	76.973	
34	-442.703787		9.991655	SiO2V	76.737	
35	143.501616		20.229593	N2VP950	77.748	
36	483.451705		9.993273	SiO2V	79.933	
37	241.810075		15.546146	N2VP950	84.505	
38	928.401379		29.795388	SiO2V	88.441	
39	-298.259102	AS	8.829909	N2VP950	94.008	
40	-1812.559641	AS	29.628322	SiO2V	101.744	
41	-270.502936		7.417032	N2VP950	107.779	
42	-7682.999744	AS	45.892645	SiO2V	118.999	
43	-231.286706		27.404554	N2VP950	122.729	
44	449.487156		46.556603	SiO2V	134.549	

TABLE 27-continued

(EM28)					
Sur- face	Radius	Asphere	Thickness	Material	$\frac{1}{2}$ Diameter
45	-668.069375		1.250913	N2VP950	134.857
46	886.959900	AS	43.269922	SiO2V	133.822
47	-295.612418		0.987420	N2VP950	133.749
48	230.112826		44.287713	SiO2V	112.987
49	-2356.132765	AS	0.978312	N2VP950	108.183
50	92.104165		41.465221	SiO2V	76.439
51	253.332614		1.131452	N2VP950	67.260
52	84.180015		39.033045	CAF2V193	50.611
53	0.000000		3.000000	H2OV193	21.082
54	0.000000		0.000000	AIR	16.500

TABLE 27A

Aspherical Constants					
Surface					
	2	5	7	20	22
K	0	0	0	0	0
C1	-7.058653e-08	-1.114728e-07	1.398385e-07	-1.149358e-08	-5.629065e-08
C2	-2.984480e-12	4.526601e-12	-6.219606e-12	-6.065516e-12	1.905377e-12
C3	-1.303901e-16	1.421882e-16	3.410808e-16	6.763250e-16	-2.554160e-16
C4	-5.960748e-21	-1.154537e-19	3.575265e-20	-7.651964e-20	6.886775e-21
C5	-6.187687e-25	1.628794e-23	-2.900443e-23	5.689563e-24	-6.938594e-25
C6	8.668981e-29	-6.255900e-28	2.343745e-27	-2.312648e-28	-2.420574e-29
C7	0.000000e+00	0.000000e+00	0.000000e+00	0.000000e+00	0.000000e+00
C8	0.000000e+00	0.000000e+00	0.000000e+00	0.000000e+00	0.000000e+00
C9	0.000000e+00	0.000000e+00	0.000000e+00	0.000000e+00	0.000000e+00

Surface					
	25	26	29	31	39
K	-2.31378	-2.31378	0	0	0
C1	-4.828221e-08	4.828221e-08	1.342570e-08	-9.018801e-08	3.278431e-08
C2	7.051572e-13	-7.051572e-13	-3.644532e-13	6.045342e-12	1.370822e-17
C3	-2.377185e-17	2.377185e-17	-2.375681e-18	-1.273791e-16	1.643036e-16
C4	6.284480e-22	-6.284480e-22	-3.970849e-22	-2.702171e-21	-2.021350e-20
C5	-1.385194e-26	1.385194e-26	-4.372813e-27	3.262226e-25	2.670722e-24
C6	1.514567e-31	-1.514567e-31	6.283103e-31	-6.948598e-30	-1.187217e-28
C7	0.000000e+00	0.000000e+00	0.000000e+00	0.000000e+00	0.000000e+00
C8	0.000000e+00	0.000000e+00	0.000000e+00	0.000000e+00	0.000000e+00
C9	0.000000e+00	0.000000e+00	0.000000e+00	0.000000e+00	0.000000e+00

Surface					
	40	42	46	49	
K	0	0	0	0	
C1	-5.316551e-08	-1.954895e-09	-4.282391e-08	-3.095959e-08	
C2	-7.707570e-14	5.606761e-14	-1.948121e-13	3.451241e-12	
C3	2.146900e-16	-6.199304e-17	7.664802e-17	-1.219768e-16	
C4	-2.184878e-20	3.478339e-21	-2.354982e-21	4.060098e-21	
C5	2.255720e-24	-1.558932e-25	1.361973e-26	-9.053687e-26	
C6	-9.545251e-29	4.899450e-30	2.019923e-31	1.610152e-30	
C7	0.000000e+00	0.000000e+00	0.000000e+00	0.000000e+00	
C8	0.000000e+00	0.000000e+00	0.000000e+00	0.000000e+00	
C9	0.000000e+00	0.000000e+00	0.000000e+00	0.000000e+00	

TABLE 28

(EM25)				
WL	193.368 nm	193.468 nm	193.268 nm	
SIO2V'	1.5607857	1.56062813	1.56094365	
CAF2V193'	1.50175423	1.50185255	1.50195109	
H2OV193'	1.4364632	1.43667693	1.43689123	

NA 1.2; Fmin = 18.63 mm; Fmax = 66 mm				
Surface	Radius	Thickness	Material	½Diam. Type
0	0.00000000	31.974939715	AIR	66.000
1	0.00000000	-0.024765663	AIR	76.143
2	148.940822391	31.463360093	SIO2V	83.171
3	6331.489300420	40.453855135	AIR	83.210
4	928.302406310	14.994423747	SIO2V	83.796
5	251.967918823	13.753137508	AIR	83.372
6	172.912005335	50.243372901	SIO2V	87.569
7	-197.856766081	1.000964332	AIR	86.631
8	81.522536296	17.681593406	SIO2V	65.574
9	88.327907526	30.256558951	AIR	60.047
10	117.551427452	18.843304175	SIO2V	50.042
11	855.507852453	8.921765220	AIR	45.493
12	0.00000000	0.000000000	AIR	37.552
13	0.00000000	49.799403498	AIR	37.641
14	-56.887108985	19.216557050	SIO2V	46.868
15	-153.952881762	0.978745522	AIR	66.363
16	-10783.364868000	53.980836551	SIO2V	79.120
17	-370.423261824	5.444267505	AIR	97.662
18	-1928.185768980	46.883883025	SIO2V	104.839
19	-156.534475362	0.983619441	AIR	108.499
20	-2025.935551520	37.434974978	SIO2V	114.116
21	-206.572644709	34.979106092	AIR	115.758
22	0.00000000	220.766423587	AIR	108.107
23	-187.624624543	-220.766423587	AIR	140.612 REFL
24	185.347836932	220.766423587	AIR	130.980 REFL
25	0.00000000	38.094302401	AIR	87.940
26	572.857393641	19.003060435	SIO2V	84.526
27	-2621.148115610	0.995124659	AIR	83.267
28	286.158521436	14.994640836	SIO2V	80.188
29	106.165691183	42.739053946	AIR	72.275
30	-269.972769063	14.994253287	SIO2V	72.751
31	217.103611286	19.468009312	AIR	79.551
32	49574.268497900	15.072135262	SIO2V	82.355
33	-1724.117745890	7.993795407	AIR	87.009
34	-681.152171807	39.742301517	SIO2V	89.501
35	-135.848489522	0.995182990	AIR	93.025
36	729.076676327	18.240313704	SIO2V	99.335
37	-1221.183105010	8.112527507	AIR	100.052
38	470.281491581	33.610782817	SIO2V	101.641
39	-393.774605114	34.640728842	AIR	101.306
40	-135.515968276	14.997016204	SIO2V	100.625
41	-242.973369762	0.998166637	AIR	109.176
42	629.218885691	33.238719341	SIO2V	114.327
43	-476.667589984	1.000069241	AIR	114.673
44	609.210504505	31.634185939	SIO2V	112.966
45	-463.558570174	0.991784251	AIR	112.249
46	181.331821629	26.489265851	SIO2V	99.538
47	478.467068575	0.985154964	AIR	96.400
48	166.964883598	32.619952496	SIO2V	90.254
49	34746.976265700	0.961982243	AIR	86.267
50	65.547601143	30.975153472	SIO2V	58.849
51	118.066733717	1.052010322	AIR	51.946
52	68.706870791	32.347686260	CAF2V193	43.646
53	0.00000000	3.000000148	H2OV193	21.134
54	0.00000000	0.000000000	AIR	16.501

TABLE 28A

Aspherical Constants					
Surface	K	C1	C2	C3	C4
2	0.00000000e+000	-5.25595959e-008	-5.05125696e-014	-3.39834764e-016	1.43455947e-022
4	0.00000000e+000	-9.82547285e-009	-3.46617126e-012	4.26908111e-016	8.30046581e-021
7	0.00000000e+000	4.35702944e-008	3.07328355e-012	-6.64471080e-016	8.46058187e-020

TABLE 28A-continued

Aspherical Constants					
11	0.0000000e+000	1.7805985e-008	-4.49918001e-011	-1.45873634e-015	-5.93868926e-020
15	0.0000000e+000	9.71039823e-009	-5.80809116e-012	1.66373755e-015	-6.79295769e-020
18	0.0000000e+000	-9.90188358e-009	-3.63667799e-012	4.39791888e-016	-4.05829074e-020
20	0.0000000e+000	-3.56668353e-008	1.04282881e-012	-3.79146258e-017	1.77203987e-021
23	-1.0000000e+000	0.0000000e+000	0.0000000e+000	0.0000000e+000	0.0000000e+000
24	0.0000000e+000	-4.12889632e-009	-9.85960529e-014	-2.94691200e-018	-3.56770055e-025
26	0.0000000e+000	2.84735678e-008	8.22076690e-013	8.98622393e-019	1.63369077e-020
36	0.0000000e+000	-3.45458233e-008	7.01690612e-013	2.53558597e-017	-2.32833922e-023
42	0.0000000e+000	6.80041144e-009	-3.73953529e-014	-4.59353922e-017	3.53253945e-021
47	0.0000000e+000	3.44340794e-008	8.40449554e-013	-3.72972761e-016	3.22089615e-020
49	0.0000000e+000	1.97298275e-008	2.76921584e-012	1.03703892e-016	-5.16050166e-020

Surface	C5	C6	C7	C8
2	5.23175535e-024	-1.25244222e-027	1.21805557e-031	-4.43910196e-036
4	-4.64399579e-024	1.19810111e-027	-1.78448775e-031	9.48653785e-036
7	-6.78485826e-024	2.18615691e-028	1.27733528e-032	-7.77343429e-037
11	2.10051516e-021	-2.86208035e-027	-1.14692199e-028	-9.07436019e-033
15	4.67315167e-024	1.33956477e-027	-1.86319592e-031	1.80116188e-036
18	3.14215669e-024	-1.78747424e-028	6.25454799e-033	-9.94933562e-038
20	-1.02830257e-025	1.63016234e-030	9.47579264e-035	-3.37443982e-039
23	0.0000000e+000	0.0000000e+000	0.0000000e+000	0.0000000e+000
24	-4.97425291e-027	1.63379520e-032	3.42393048e-036	-1.99876678e-040
26	-7.11352194e-024	7.18534327e-028	-1.59298542e-032	-4.89537949e-037
36	2.60044530e-026	-1.74079904e-030	-4.85763706e-034	2.78340967e-038
42	-9.74225973e-026	9.00308701e-031	0.0000000e+000	0.0000000e+000
47	-2.63108130e-024	2.07908763e-028	-7.57742152e-033	9.89130621e-038
49	8.50503256e-024	-9.50392825e-028	5.47302796e-032	-1.31141198e-036

TABLE 30

Sur-face	(EM29)				1/2 Diameter
	Radius	Asphere	Thickness	Material	
1	0.000000		-0.000674	LV193975	75.450
2	501.388885	AS	15.700263	SIO2V	76.793
3	-2140.989756		1.030768	HEV19397	78.495
4	142.094518		41.139801	SIO2V	86.380
5	4509.859821	AS	48.031590	HEV19397	84.694
6	294.047825		42.018849	SIO2V	75.299
7	-284.632088	AS	0.899132	HEV19397	70.073
8	196.950986		32.325473	SIO2V	62.732
9	-427.997978	AS	24.031073	HEV19397	55.024
10	0.000000		0.000000	HEV19397	35.604
11	0.000000		17.973629	HEV19397	35.604
12	0.000000		9.999076	SIO2V	45.185
13	0.000000		34.757744	HEV19397	48.346
14	997.955935	AS	34.646365	SIO2V	67.618
15	-300.927832		15.875609	HEV19397	75.070
16	-346.766852	AS	31.454835	SIO2V	80.051
17	-123.279874		36.439684	HEV19397	83.364
18	0.000000		205.977742	HEV19397	86.638
19	-174.397052	AS	-205.977742	REFL	131.209
20	170.274411	AS	205.977742	REFL	116.516
21	0.000000		37.095745	HEV19397	97.388
22	437.401009		36.383480	SIO2V	104.301
23	-468.489757		45.906894	HEV19397	104.284
4	-1223.579996		21.742866	SIO2V	97.101
5	-511.114441	AS	8.072398	HEV19397	96.542
26	432.469418		10.004999	SIO2V	85.308
27	102.889104		42.520104	HEV19397	75.234
28	-594.379481		9.996510	SIO2V	75.720
29	174.356867		19.418323	HEV19397	79.411
30	715.897359		10.937733	SIO2V	82.556
31	324.211087		13.818484	HEV19397	88.129

TABLE 30-continued

Sur-face	(EM29)					1/2 Diameter
	Radius	Asphere	Thickness	Material		
32	1110.064311		30.443596	SIO2V	93.022	
33	-264.206409	AS	7.862028	HEV19397	97.550	
34	-1190.503106	AS	29.935994	SIO2V	104.823	
35	-237.772522		11.246604	HEV19397	110.038	
36	10331.864054	AS	39.860150	SIO2V	122.900	
37	-277.281811		10.852741	HEV19397	125.931	
38	214450.764260		31.052526	SIO2V	131.630	
50	9		-428.573007	HEV19397	132.643	
40	751.599719		33.094141	SIO2V	133.007	
41	-805.999226		1.057548	HEV19397	132.758	
42	914.688148	AS	40.568688	SIO2V	130.742	
43	-348.277386		0.878766	HEV19397	129.732	
44	219.106958		38.836424	SIO2V	108.095	
45	2357.913334	AS	1.971079	HEV19397	102.766	
46	85.554437		39.388562	SIO2V	72.129	
47	193.092045		0.892017	HEV19397	62.113	
48	83.536468		37.250760	CAF2V193	49.390	
49	0.000000		0.300000	SIO2V	21.410	
50	0.000000		0.000000	SIO2V	21.050	
51	0.000000		3.000000	H2OV193B	21.050	
65	52		0.000000	AIR	16.500	

TABLE 30A

Aspherical Constants					
Surface					
	2	5	7	9	14
K	0	0	0	1.84398	0
C1	-4.426813e-08	-2.968289e-08	1.574555e-07	1.174665e-07	-3.306265e-08
C2	-6.238723e-13	5.914537e-12	-1.371133e-11	5.249946e-12	-1.008549e-12
C3	5.373027e-21	-2.636410e-17	7.979944e-16	0.000000e+00	-2.352647e-16
C4	5.520432e-21	-2.348783e-20	-1.733518e-21	0.000000e+00	2.617179e-25
C5	-4.165047e-25	1.589258e-24	-1.045941e-23	0.000000e+00	-1.275061e-24
C6	-2.539882e-29	-3.710160e-29	1.048551e-27	0.000000e+00	7.076571e-29
C7	0.000000e+00	0.000000e+00	0.000000e+00	0.000000e+00	0.000000e+00
C8	0.000000e+00	0.000000e+00	0.000000e+00	0.000000e+00	0.000000e+00
C9	0.000000e+00	0.000000e+00	0.000000e+00	0.000000e+00	0.000000e+00

Surface					
	16	19	20	25	33
K	0	-2.01302	-2.06565	0	0
C1	-4.975918e-08	-3.276866e-08	4.322230e-08	-1.196195e-07	2.211028e-08
C2	1.193440e-12	3.671721e-13	-3.203678e-13	6.474093e-12	7.931065e-13
C3	-3.326252e-18	-8.127219e-18	1.331133e-17	-2.172807e-16	2.746964e-17
C4	5.194442e-21	1.823894e-22	-2.254203e-22	5.562468e-21	-3.773718e-21
C5	7.844572e-25	-2.990635e-27	4.731338e-27	4.566785e-26	8.556577e-25
C6	-3.910445e-29	4.402752e-32	-3.185999e-32	-6.729599e-30	-5.193468e-29
C7	0.000000e+00	0.000000e+00	0.000000e+00	0.000000e+00	0.000000e+00
C8	0.000000e+00	0.000000e+00	0.000000e+00	0.000000e+00	0.000000e+00
C9	0.000000e+00	0.000000e+00	0.000000e+00	0.000000e+00	0.000000e+00

Surface				
	34	36	42	45
K	0	0	0	0
C1	-6.109386e-08	-2.940384e-09	-3.072861e-08	-4.317432e-08
C2	1.186926e-12	-1.302883e-13	1.225198e-13	5.093533e-12
C3	9.338913e-17	-7.457684e-17	6.438064e-17	-2.542515e-16
C4	-8.049754e-21	4.922730e-21	-2.717739e-21	1.185033e-20
C5	7.964565e-25	-1.822077e-25	3.936453e-26	-3.870604e-25
C6	-3.877045e-29	3.491116e-30	-1.518766e-31	7.346646e-30
C7	0.000000e+00	0.000000e+00	0.000000e+00	0.000000e+00
C8	0.000000e+00	0.000000e+00	0.000000e+00	0.000000e+00
C9	0.000000e+00	0.000000e+00	0.000000e+00	0.000000e+00

TABLE 31

(EM29)					
Sur-face	Radius	Asphere	Thickness	Material	1/2 Diameter
1	0.000000		-0.012399	LV193975	75.472
2	154.966472	AS	24.304901	SIO2V	82.008
3	529.820026		2.090993	HEV19397	82.074
4	150.769271		40.595812	SIO2V	84.201
5	5646.002857		29.581615	HEV19397	81.519
6	-1210.857565		22.741810	SIO2V	74.381
7	-182.994045	AS	34.025994	HEV19397	72.364
8	173.187773		25.484337	SIO2V	52.132
9	-296.185557		22.382287	HEV19397	47.253
10	0.000000		10.110510	SIO2V	44.035
11	0.000000		17.152556	HEV19397	46.863
12	51884.400557	AS	16.631540	SIO2V	54.537
13	-361.923018		63.995754	HEV19397	58.291
14	-878.387785	AS	34.625490	SIO2V	82.453
15	-136.078636		36.436642	HEV19397	85.494
16	0.000000		196.253966	HEV19397	89.191
17	-182.153238	AS	-196.253966	REFL	149.252
18	150.956725	AS	196.253966	REFL	101.676
19	0.000000		36.446112	HEV19397	104.396
20	333.439228		55.820683	SIO2V	116.602
21	-309.405465		37.869545	HEV19397	116.527

TABLE 31-continued

(EM29)					
Sur-face	Radius	Asphere	Thickness	Material	1/2 Diameter
22	-424.165104		20.518575	SIO2V	104.186
23	-285.104268	AS	0.896321	HEV19397	103.405
24	635.351851		9.997637	SIO2V	92.108
25	107.969149		40.308038	HEV19397	80.454
26	389.814743		9.996225	SIO2V	82.006
27	152.951561		26.349381	HEV19397	81.938
28	1310.914891		9.999638	SIO2V	84.278
29	275.521100		17.511021	HEV19397	89.677
30	1763.795762		26.773314	SIO2V	93.617
31	-289.165601	AS	9.639413	HEV19397	97.853
32	-1578.752955	AS	27.680692	SIO2V	106.237
33	-272.338400		9.732573	HEV19397	110.951
34	-3842.769867	AS	35.516033	SIO2V	122.549
35	-314.937511		28.595034	HEV19397	125.359
36	889.868029		47.614171	SIO2V	135.827
37	-355.067891		-12.204373	HEV19397	136.279
38	0.000000		0.000000	HEV19397	133.729
39	0.000000		28.717983	HEV19397	133.729
40	574.174423	AS	45.539693	SIO2V	132.500
41	-344.516223		0.852315	HEV19397	132.025
42	204.978326		45.863613	SIO2V	111.958

TABLE 31-continued

(EM29)					
Sur-face	Radius	Asphere	Thickness	Material	$\frac{1}{2}$ Diameter
43	-6283.361425	AS	0.828469	HEV19397	106.831
44	87.555579		40.313564	SIO2V	74.022
45	201.419511		0.722913	HEV19397	64.044
46	86.647656		38.420734	CAF2V193	50.908
47	0.000000		0.300000	SIO2V	21.485
48	0.000000		0.000000	SIO2V	21.121
49	0.000000		3.000000	H2OV193B	21.121
50	0.000000		0.000000	AIR	16.500

TABLE 32-continued

(EM29)					
Sur-face	Radius	Asphere	Thickness	Material	$\frac{1}{2}$ Diameter
3	-766.901651		0.890161	HEV19397	78.252
4	145.560665		45.675278	SIO2V	85.645
5	2818.543789	AS	40.269525	HEV19397	83.237
6	469.396236		29.972759	SIO2V	75.894
7	-193.297708	AS	21.997025	HEV19397	73.717
8	222.509238		27.666963	SIO2V	57.818
9	-274.231957		31.483375	HEV19397	52.595
10	0.000000		10.117766	SIO2V	44.115
11	0.000000		15.361487	HEV19397	47.050

TABLE 31A

Aspherical Constants						
Surface						
	2	7	12	14	17	
K	0	0	0	0	0	-205.145
C1	-5.06E-02	1.55E-01	-6.58E-02	-3.99E-02	-3.00E-02	
C2	-1.36E-06	-4.50E-06	6.94E-07	7.46E-07	3.06E-07	
C3	-1.39E-10	2.86E-10	-8.42E-10	-4.18E-11	-7.06E-12	
C4	2.02E-14	3.18E-14	3.01E-14	-4.94E-18	1.35E-16	
C5	-1.21E-18	-4.70E-18	9.27E-20	2.51E-19	-2.46E-21	
C6	7.59E-23	2.24E-22	-5.52E-22	-2.26E-23	2.42E-26	
C7	0.000000e+00	0.000000e+00	0.000000e+00	0.000000e+00	0.000000e+00	
C8	0.000000e+00	0.000000e+00	0.000000e+00	0.000000e+00	0.000000e+00	
C9	0.000000e+00	0.000000e+00	0.000000e+00	0.000000e+00	0.000000e+00	
Surface						
	18	23	31	32	34	
K	-19.986	0	0	0	0	
C1	5.81E-02	-5.44E-02	2.45E-02	-6.17E-02	2.25E-02	
C2	-5.04E-07	5.13E-06	5.17E-07	1.84E-06	-1.23E-06	
C3	2.61E-11	-2.58E-10	4.76E-11	9.77E-11	-5.97E-11	
C4	-5.07E-16	1.19E-14	-1.55E-15	-8.36E-15	6.09E-15	
C5	1.40E-20	-3.68E-19	8.15E-19	8.28E-19	-2.59E-19	
C6	-4.71E-26	5.92E-24	-4.46E-23	-3.91E-23	5.18E-24	
C7	0.000000e+00	0.000000e+00	0.000000e+00	0.000000e+00	0.000000e+00	
C8	0.000000e+00	0.000000e+00	0.000000e+00	0.000000e+00	0.000000e+00	
C9	0.000000e+00	0.000000e+00	0.000000e+00	0.000000e+00	0.000000e+00	
Surface						
	40	43				
K	0	0				
C1	-3.76E-02	-2.60E-02				
C2	7.18E-08	3.27E-06				
C3	5.92E-11	-1.25E-10				
C4	-1.80E-15	4.09E-15				
C5	7.98E-21	-8.18E-20				
C6	1.92E-25	8.62E-25				
C7	0.000000e+00	0.000000e+00				
C8	0.000000e+00	0.000000e+00				
C9	0.000000e+00	0.000000e+00				

TABLE 32

(EM29)					
Sur-face	Radius	Asphere	Thickness	Material	$\frac{1}{2}$ Diameter
1	0.000000		-0.011620	LV193975	75.462
2	585.070331	AS	17.118596	SIO2V	76.447

TABLE 32-continued

(EM29)					
Sur-face	Radius	Asphere	Thickness	Material	$\frac{1}{2}$ Diameter
12	26971.109897	AS	14.803554	SIO2V	54.127
13	-562.070426		45.416373	HEV19397	58.058

TABLE 32-continued

(EM29)					5
Sur- face	Radius	Asphere	Thickness	Material	1/2 Diameter
14	-510.104298	AS	35.926312	SIO2V	76.585
15	-118.683707		36.432152	HEV19397	80.636
16	0.000000		199.241665	HEV19397	86.561
17	-181.080772	AS	-199.241665	REFL	147.684
18	153.434246	AS	199.241665	REFL	102.596
19	0.000000		36.432584	HEV19397	105.850
20	408.244008		54.279598	SIO2V	118.053
21	-296.362521		34.669451	HEV19397	118.398
22	-1378.452784		22.782283	SIO2V	106.566
23	-533.252331	AS	0.892985	HEV19397	105.292
24	247.380841		9.992727	SIO2V	92.481
25	103.088603		45.957039	HEV19397	80.536
26	-1832.351074		9.992069	SIO2V	80.563
27	151.452362		28.883857	HEV19397	81.238
28	693.739003		11.559320	SIO2V	86.714
29	303.301679		15.104783	HEV19397	91.779
30	1016.426625		30.905849	SIO2V	95.900
31	-258.080954	AS	10.647394	HEV19397	99.790

TABLE 32-continued

(EM29)						
Sur- face	Radius	Asphere	Thickness	Material	1/2 Diameter	
10	32	-1386.614747	AS	24.903261	SIO2V	108.140
	33	-305.810572		14.249112	HEV19397	112.465
	34	-11755.656826	AS	32.472684	SIO2V	124.075
	35	-359.229865		16.650084	HEV19397	126.831
	36	1581.896158		51.095339	SIO2V	135.151
	37	-290.829022		-5.686977	HEV19397	136.116
	38	0.000000		0.000000	HEV19397	131.224
	39	0.000000		28.354383	HEV19397	131.224
	40	524.037274	AS	45.835992	SIO2V	130.144
	41	-348.286331		0.878010	HEV19397	129.553
	42	184.730622		45.614622	SIO2V	108.838
	43	2501.302312	AS	0.854125	HEV19397	103.388
	44	89.832394		38.416586	SIO2V	73.676
	45	209.429378		0.697559	HEV19397	63.921
	46	83.525032		37.916651	CAF2V193	50.040
	47	0.000000		0.300000	SIO2V	21.480
	48	0.000000		0.000000	SIO2V	21.116
	49	0.000000		3.000000	H2OV193B	21.116
	50	0.000000		0.000000	AIR	16.500

TABLE 32A

Aspherical Constants						
Surface						
	2	5	7	12	14	
K	0	0	0	0	0	0
C1	-5.72E-02	-4.71E-02	1.75E-01	-8.29E-02	-4.35E-02	
C2	-2.97E-07	7.04E-06	-1.17E-05	-1.87E-07	1.59E-06	
C3	1.03E-12	1.09E-10	1.34E-09	-7.04E-10	-6.81E-11	
C4	2.76E-14	-2.90E-14	-5.44E-14	6.65E-14	5.03E-15	
C5	-1.51E-18	-1.55E-21	-1.82E-18	-1.33E-17	-1.68E-23	
C6	-1.04E-24	5.61E-23	2.56E-22	2.46E-21	-2.36E-23	
C7	0.000000e+00	0.000000e+00	0.000000e+00	0.000000e+00	0.000000e+00	
C8	0.000000e+00	0.000000e+00	0.000000e+00	0.000000e+00	0.000000e+00	
C9	0.000000e+00	0.000000e+00	0.000000e+00	0.000000e+00	0.000000e+00	
Surface						
	17	18	23	31	32	
K	-197.849	-204.054	0	0	0	
C1	-2.94E-02	5.77E-02	-7.06E-02	3.41E-02	-4.85E-02	
C2	2.63E-07	-5.00E-07	4.11E-06	4.07E-08	9.88E-07	
C3	-6.11E-12	2.67E-11	-1.18E-10	8.10E-11	7.37E-11	
C4	1.11E-16	-5.69E-16	2.92E-15	-4.34E-15	-6.56E-15	
C5	-2.01E-21	1.89E-20	-3.23E-20	7.59E-19	6.53E-19	
C6	2.08E-26	-1.49E-25	2.18E-25	-3.41E-23	-2.88E-23	
C7	0.000000e+00	0.000000e+00	0.000000e+00	0.000000e+00	0.000000e+00	
C8	0.000000e+00	0.000000e+00	0.000000e+00	0.000000e+00	0.000000e+00	
C9	0.000000e+00	0.000000e+00	0.000000e+00	0.000000e+00	0.000000e+00	

TABLE 32A-continued

Aspherical Constants				
	Surface			
	34	40	43	
K	0	0	0	
C1	1.59E-02	-4.10E-02	-3.89E-02	
C2	-1.51E-06	3.04E-07	4.76E-06	
C3	6.62E-13	5.71E-11	-2.23E-10	
C4	1.72E-15	-1.72E-15	8.89E-15	
C5	-9.36E-20	-9.60E-22	-2.41E-19	
C6	2.36E-24	3.81E-25	3.43E-24	
C7	0.000000e+00	0.000000e+00	0.000000e+00	
C8	0.000000e+00	0.000000e+00	0.000000e+00	
C9	0.000000e+00	0.000000e+00	0.000000e+00	

TABLE 34

(EM26)			
WL	193.368 nm	193.468 nm	193.268 nm
SIO2V'	1.5607857	1.56062813	1.56094365
CAF2V193'	1.50175423	1.50185255	1.50195109
H2OV193'	1.4364632	1.43667693	1.43689123

NA 1.2; Fmin = 18.63 mm; Fmax = 66 mm					
Surface	Radius	Thickness	Material	1/2Diam.	Type
0	0.000000000	31.982585487	AIR	66.000	
1	0.000000000	-0.017071913	AIR	76.172	
2	147.976296433	25.157601132	SIO2V	83.329	
3	483.267348199	66.318217434	AIR	83.329	
4	6843.187124890	14.990603080	SIO2V	89.462	
5	-10922.857227200	0.990910304	AIR	89.696	
6	185.444884732	43.423576628	SIO2V	90.336	
7	-291.453552095	0.988388071	AIR	88.691	
8	75.552245567	18.214694705	SIO2V	66.883	
9	76.794787833	36.638500036	AIR	60.819	
10	119.890093734	18.824651829	SIO2V	50.527	
11	1688.559592410	8.584817314	AIR	45.933	
12	0.000000000	0.000000000	AIR	38.451	
13	0.000000000	52.042672045	AIR	38.545	
14	-59.826650342	14.981853380	SIO2V	48.449	
15	-143.442731652	0.981820223	AIR	65.183	
16	-809.267677971	22.623991877	SIO2V	74.792	
17	-189.427877067	23.734179117	AIR	79.164	
18	-404.048228936	40.321323389	SIO2V	94.462	
19	-133.255827443	0.996126038	AIR	98.239	
20	-532.626067795	25.229572964	SIO2V	102.508	
21	-218.631437997	34.992902498	AIR	104.152	
22	0.000000000	232.569743258	AIR	102.146	
23	-203.850853866	-232.569743258	AIR	154.862	REFL
24	180.897913619	232.569743258	AIR	125.795	REFL
25	0.000000000	35.093353727	AIR	89.945	
26	-2097.871590640	18.902530877	SIO2V	88.318	
27	-311.592066935	1.000926290	AIR	88.349	
28	197.040247642	14.994864591	SIO2V	82.980	
29	123.794489384	39.397144698	AIR	76.695	
30	-351.625590566	14.996140251	SIO2V	76.667	
31	194.519969585	25.840876165	AIR	79.734	
32	-783.090311926	14.999335864	SIO2V	81.725	
33	602.209892650	15.636785753	AIR	89.884	
34	-860.877333066	40.308090334	SIO2V	92.572	
35	-144.751331394	0.995503627	AIR	96.367	
36	489.496864563	22.261422840	SIO2V	107.265	
37	-1492.086252490	0.998123009	AIR	108.225	
38	542.517785037	42.667711177	SIO2V	110.092	
39	-278.956019182	30.784648856	AIR	110.074	
40	-143.206504187	16.457194925	SIO2V	109.358	
41	-245.275186574	0.991006459	AIR	118.513	
42	450.076146500	56.637715430	SIO2V	124.493	
43	-281.238265383	0.994417156	AIR	124.569	
44	173.286659802	30.025805518	SIO2V	105.228	
45	405.488019133	4.969943131	AIR	101.974	
46	170.349078374	38.966672867	SIO2V	93.740	

TABLE 34-continued

(EM26)				
47	78634.784391100	0.980473718	AIR	86.875
48	65.899645851	30.022369482	SIO2V	58.766
49	115.328388498	0.871701885	AIR	51.820
50	70.957276330	32.640666401	CAF2V193	44.305
51	0.000000000	3.000000148	H2OV193	21.157
52	0.000000000	0.000000000	AIR	16.500

TABLE 34A

Aspherical Constants					
Surface K	C1	C2	C3	C4	
2	0.00000000e+000	-4.78882631e-008	-1.07874702e-012	-3.02679637e-016	1.88733824e-020
4	0.00000000e+000	6.93936013e-009	4.14547565e-012	-2.44188432e-016	3.37511708e-020
7	0.00000000e+000	2.35987002e-008	8.31924580e-012	-7.77774842e-016	6.50303307e-021
11	0.00000000e+000	1.26922184e-007	-4.36848744e-011	4.57206313e-015	1.74083492e-018
15	0.00000000e+000	7.93042774e-008	-2.07633723e-013	3.76353009e-016	7.36365299e-020
18	0.00000000e+000	-1.97913247e-009	-8.66959877e-013	6.04641277e-017	-4.73473989e-021
20	0.00000000e+000	-5.08811298e-009	-3.02758381e-013	-6.93452917e-018	3.42662757e-022
23	0.00000000e+000	9.00942854e-009	1.77368463e-013	2.86086903e-018	5.71387977e-023
24	0.00000000e+000	-6.79867230e-009	-1.66279668e-013	-3.17226607e-018	-2.14919508e-022
26	0.00000000e+000	-5.37053896e-008	1.67618239e-012	4.07995560e-016	-3.53050500e-020
36	0.00000000e+000	-3.31965207e-008	6.14833787e-013	2.40373774e-017	1.18984531e-022
41	0.00000000e+000	-1.38336514e-008	8.93474375e-013	-2.71551009e-017	1.74375713e-021
45	0.00000000e+000	1.44983141e-008	-1.95881989e-014	-1.05859436e-016	5.32744894e-021
47	0.00000000e+000	3.11232761e-008	2.84716248e-012	-1.11706969e-016	-2.66038924e-021

Surface	C5	C6	C7	C8	
2	-4.39149695e-025	-1.09132516e-028	-1.04998811e-035	7.96689244e-037	
4	-5.06638092e-024	5.32303197e-028	-2.85457308e-032	3.58175757e-038	
7	3.23059366e-024	-1.16477659e-030	-4.43574135e-032	2.44981381e-036	
11	-1.38306535e-022	2.43454067e-025	-8.52163913e-029	1.77790237e-034	
15	-4.68407947e-024	8.91865260e-029	8.87815151e-032	-8.32251546e-036	
18	1.77442213e-025	4.52110292e-031	-2.53815340e-035	-4.30166930e-039	
20	-9.21678831e-028	-3.68127185e-033	1.89749139e-038	-4.16625182e-039	
23	-4.46902171e-028	1.13482418e-031	-3.89411163e-036	7.97497644e-041	
24	1.19742697e-026	-1.09727605e-030	4.00797914e-035	-7.95846450e-040	
26	9.00535444e-025	-3.46673523e-029	-6.86798043e-033	5.92310794e-037	
36	-9.53667910e-026	4.93885674e-030	-2.90808572e-034	1.22198832e-039	
41	-1.26665751e-025	5.84505761e-030	-2.30469572e-034	6.06339556e-039	
45	-5.94726685e-026	2.48643254e-029	-1.88792088e-033	5.60469477e-038	
47	2.43106684e-025	-3.95551801e-029	-7.28245783e-037	4.70291791e-038	

TABLE 36

(EM27)			
WL	193.368 nm	193.468 nm	193.268 nm
SIO2V'	1.5607857	1.56062813	1.56094365
CAF2V193'	1.50175423	1.50185255	1.50195109
H2OV193'	1.4364632	1.43667693	1.43689123

NA 1.2; Fmin = 18.63 mm; Fmax = 66 mm

Surface	Radius	Asphere	Thickness	Material	½ Diameter
1	0.000000		-0.004216	LUFTV193	75.440
2	341.127979	AS	22.791928	SIO2V	77.399
3	-547.910038		0.998331	N2VP950	79.138
4	127.727169		41.232021	SIO2V	85.886
5	423.981317	AS	37.538965	N2VP950	83.125
6	1837.865411		20.893107	SIO2V	73.497
7	-224.309944	AS	1.002068	N2VP950	71.189
8	162.793881		28.373758	SIO2V	63.095
9	-357.404285		20.328095	N2VP950	58.827
10	-130.668159		9.997405	SIO2V	40.623
11	-153.854050		6.572008	N2VP950	37.125
12	0.000000		9.999712	SIO2V	37.199
13	0.000000		1.062092	N2VP950	40.839
14	743.447647		18.547401	SIO2V	42.269
15	-194.707721		22.944701	N2VP950	46.232

TABLE 36-continued

(EM27)				
16	-91.226681		9.997232 SIO2V	51.224
17	-149.640287		18.143695 N2VP950	58.055
18	-523.085587	AS	23.764093 SIO2V	70.561
19	-159.366370		0.999029 N2VP950	75.025
20	-418.047917	AS	30.390060 SIO2V	78.905
21	-139.497541		36.995337 N2VP950	82.309
22	0.000000		202.057337 N2VP950	86.976
23	-179.767561	AS	-202.057337 REFL	144.017
24	157.031815	AS	202.057337 REFL	107.178
25	0.000000		36.997499 N2VP950	101.742
26	440.441126		47.272805 SIO2V	111.232
27	-305.204169		41.252868 N2VP950	111.473
28	-462.717592		18.096500 SIO2V	101.263
29	-434.773502	AS	1.272365 N2VP950	100.762
30	323.034266		9.997203 SIO2V	90.351
31	107.871517		41.101537 N2VP950	80.055
32	-2104.261715		9.996146 SIO2V	80.354
33	162.693545		24.114798 N2VP950	82.448
34	461.867528		1.590831 SIO2V	88.405
35	292.431899		14.861810 N2VP950	92.938
36	1076.736610		38.645047 SIO2V	96.114
37	-233.326361	AS	4.528881 N2VP950	101.701
38	-818.919435	AS	26.752850 SIO2V	107.052
39	-301.917563		18.307802 N2VP950	113.375
40	-2069.863617	AS	54.519854 SIO2V	125.923
41	-240.586609		40.043329 N2VP950	131.701
42	0.000000		0.000000 N2VP950	138.484
43	0.000000		-20.273619 N2VP950	138.484
44	442.810512		63.820483 SIO2V	138.949
45	-533.873885		2.798052 N2VP950	139.304
46	662.397337	AS	40.282382 SIO2V	135.640
47	-428.200815		0.994361 N2VP950	134.489
48	213.024607		43.377768 SIO2V	113.450
49	3009.037627	AS	0.987971 N2VP950	107.741
50	95.712001		40.028327 SIO2V	77.581
51	241.528599		2.069796 N2VP950	67.915
52	85.826880		38.946996 CAF2V193	50.851
53	0.000000		3.000000 H2OV193	21.090
54	0.000000		0.000000 AIR	16.500

TABLE 36A

Aspherical Constants					
Surface					
	2	5	7	18	20
K	0	0	0	0	0
C1	-6.825898e-08	-1.139291e-07	1.715001e-07	-5.525454e-08	-1.928670e-08
C2	-5.820149e-13	6.229489e-12	-3.362340e-12	-1.835201e-13	1.369964e-12
C3	-1.764721e-16	2.070760e-16	2.245144e-16	1.097082e-16	-1.178098e-16
C4	1.898479e-20	-3.072912e-20	6.731621e-20	2.983525e-22	-5.533661e-22
C5	-2.878598e-26	5.780651e-25	-1.102455e-23	-7.073376e-25	4.333159e-25
C6	-4.377548e-29	7.588531e-29	1.662149e-28	2.028418e-28	-5.576742e-29
C7	0.000000e+00	0.000000e+00	0.000000e+00	0.000000e+00	0.000000e+00
C8	0.000000e+00	0.000000e+00	0.000000e+00	0.000000e+00	0.000000e+00
C9	0.000000e+00	0.000000e+00	0.000000e+00	0.000000e+00	0.000000e+00
Surface					
	23	24	29	37	38
K	-1.94543	-2.30892	0	0	0
C1	-2.949816e-08	6.225716e-08	-9.081623e-08	1.700564e-08	-5.539058e-08
C2	2.672898e-13	-8.664624e-13	4.328932e-12	7.578402e-13	7.069194e-13
C3	-5.319153e-18	3.983466e-17	-9.663515e-17	6.487979e-17	7.954509e-17
C4	1.038342e-22	-1.106567e-21	1.861873e-21	-4.481439e-21	-5.116182e-21
C5	-1.448694e-27	3.014885e-26	-2.365064e-26	9.785695e-25	7.622924e-25
C6	1.457411e-32	-3.386885e-31	4.413420e-31	-4.763684e-29	-3.862189e-29
C7	0.000000e+00	0.000000e+00	0.000000e+00	0.000000e+00	0.000000e+00
C8	0.000000e+00	0.000000e+00	0.000000e+00	0.000000e+00	0.000000e+00
C9	0.000000e+00	0.000000e+00	0.000000e+00	0.000000e+00	0.000000e+00

TABLE 36A-continued

Aspherical Constants			
	Surface		
	40	46	49
K	0	0	0
C1	-6.320049e-10	-2.772679e-08	-2.949915e-08
C2	-1.306440e-13	-1.390524e-13	3.478719e-12
C3	-3.923481e-17	4.871921e-17	-1.481636e-16
C4	2.072577e-21	-1.427007e-21	6.052349e-21
C5	-6.511387e-26	7.907911e-27	-1.731162e-25
C6	1.538497e-30	1.183697e-31	2.820274e-30
C7	0.000000e+00	0.000000e+00	0.000000e+00
C8	0.000000e+00	0.000000e+00	0.000000e+00
C9	0.000000e+00	0.000000e+00	0.000000e+00

TABLE 37

20

TABLE 37-continued

(j342p)						(j342p)					
Sur-face	Radius	Asphere	Thickness	Material	½ Diameter	Sur-face	Radius	Asphere	Thickness	Material	½ Diameter
0	0.000000		32.000671		66.0	25					
1	153.319623		25.301467	SILUV	83.9	30	4756.567563		10.000836	SILUV	78.0
2	362.312706		1.846656		83.3	31	153.387698		31.977828		78.4
3	249.932462		10.039369	SILUV	83.5	32	-621.996267		10.519453	SILUV	80.7
4	296.617151		16.156206		82.9	33	337.392641		11.072501		89.8
5	129.380687		32.591808	SILUV	85.8	34	737.023107		38.757083	SILUV	94.6
6	353.939024		25.413158		83.3	35	-226.600466		0.999349		98.8
7	441.659706		33.067185	SILUV	77.6	36	2080.296355		23.152743	SILUV	107.0
8	-249.821483		0.999731		73.0	37	-464.590999		1.039809		110.3
9	242.432431		23.800036	SILUV	66.0	38	1055.490633		38.268883	SILUV	115.5
10	-418.172385		16.233683		62.2	39	-319.028277		39.203877		117.8
11	-135.497448		9.999688	SILUV	53.8	40	653.756661		35.609928	SILUV	125.1
12	-172.144731		14.407576		51.0	41	-584.439739		12.416338		125.1
13	0.000000		14.446986		37.2	42	531.560104		43.648724	SILUV	121.9
14	403.537798		17.810754	SILUV	47.2	43	-344.752529		0.999813		121.1
15	-250.734154		43.083755		50.0	44	216.368978		41.075323	SILUV	104.1
16	-86.913472		14.999924	SILUV	58.5	45	-1287.916059		1.004925		99.2
17	-119.371112		3.501271		67.2	46	80.185742		39.619634	SILUV	69.4
18	-227.124051		29.708033	SILUV	72.5	47	176.364295		1.538101		59.8
19	-115.706665		0.999372		77.3	48	85.292538		38.558988	SILUV	48.9
20	-6458.564488		21.246094	SILUV	81.9	49	0.000000		3.000000	H2O	21.1
21	-316.595524		244.245108		83.5	50	0.000000				16.5
22	-175.503346		-209.246168	REFL	137.3						
23	172.837073		259.698197	REFL	116.6						
24	286.122846		54.616082	SILUV	114.1						
25	-319.487475		0.999912		113.6						
26	966.963595		26.197513	SILUV	104.1						
27	-1040.269926		1.072535		101.1						
28	1363.207517		10.039037	SILUV	93.7						
29	99.625589		52.260353		77.5						

TABLE 37A

Aspherical Constants					
	Surface				
	3	8	20	22	23
K	0	0	0	-2.68078	-2.40925
C1	-3.607637E-08	1.865463E-07	-2.924038E-08	-4.659443E-08	5.109968E-08
C2	-2.229774E-12	-7.002614E-12	-1.606274E-13	1.037806E-12	-5.972057E-13
C3	-9.424200E-17	6.321555E-16	-3.464603E-17	-3.569130E-17	2.704163E-17
C4	2.475481E-20	-2.270568E-20	-8.460050E-22	1.252351E-21	-7.866414E-22
C5	-2.200899E-24	-7.376870E-24	-3.093437E-26	-4.105857E-26	3.951644E-26
C6	2.031865E-28	4.292117E-28	1.330447E-29	1.072302E-30	-1.866653E-30
C7	-1.376196E-32	-4.030529E-32	-2.982210E-33	-1.880272E-35	6.750678E-35
C8	1.838592E-38	6.145449E-36	1.368410E-37	1.598017E-40	-1.047201E-39

TABLE 37A-continued

Aspherical Constants					
Surface					
	27	36	38	42	45
K	0	0	0	0	0
C1	-7.658966E-08	-5.016408E-08	-9.533350E-10	-3.314101E-08	-6.295604E-09
C2	5.681524E-12	6.321012E-13	-5.085963E-13	3.915833E-13	2.792116E-12
C3	-2.238871E-16	1.067455E-16	-9.972640E-17	5.982003E-17	-1.225842E-16
C4	5.298747E-21	-7.397651E-21	6.787141E-21	-1.575240E-21	1.102964E-20
C5	6.569464E-25	1.926832E-25	-1.791598E-25	-3.559970E-26	-1.065854E-24
C6	-9.223653E-29	6.753657E-30	-3.368098E-30	1.054274E-30	8.785997E-29
C7	5.022050E-33	-9.556799E-34	3.525219E-34	1.406168E-35	-4.393692E-33
C8	-1.105440E-37	1.329917E-38	-3.436374E-39	-3.845075E-40	1.041770E-37

TABLE 38

(j344p)					
Sur-face	Radius	Asphere	Thickness	Material	½ Diameter
0	0.000000		35.248514		66.0
1	143.248122		28.781110	SILUV	86.3
2	358.453084		2.742037		85.3
3	249.892226		15.480033	SILUV	85.2
4	590.981355		14.283399		84.5
5	117.666799		24.212151	SILUV	83.0
6	167.854363		18.418499		79.6
7	383.299246		37.170753	SILUV	78.0
8	-249.806207		1.005138		72.8
9	176.708488		25.812894	SILUV	64.2
10	-489.209320		17.845992		60.0
11	-138.689463		10.119648	SILUV	47.3
12	-180.883089		11.123457		43.8
13	1814.626805		14.880881	SILUV	38.4
14	-249.444318		45.270915		42.1
15	-80.916188		15.005805	SILUV	54.4
16	-125.947065		2.167332		65.0
17	-470.801754		30.186754	SILUV	72.8
18	-134.611795		2.050714		78.1
19	-522.384219		31.415391	SILUV	84.0
20	-154.268791		249.623006		87.1
21	-181.420630		-209.608609	REFL	140.1
22	169.119629		250.842406	REFL	114.7
23	291.616363		51.793776	SILUV	110.3
24	-309.683041		17.091881		109.8
25	-940.483291		12.127436	SILUV	99.3
26	-42805.292832		1.002005		97.3

TABLE 38-continued

(j344p)					
Sur-face	Radius	Asphere	Thickness	Material	½ Diameter
27	220.631691		10.003981	SILUV	88.3
28	99.320400		49.161757		77.3
29	-561.336190		9.999954	SILUV	77.2
30	154.957512		24.909934		79.0
31	1924.820454		13.223705	SILUV	81.7
32	303.786903		14.995612		89.2
33	1300.890310		31.155401	SILUV	93.9
34	-258.803624		9.929012		98.4
35	-3575.038127		30.701987	SILUV	109.0
36	-265.328196		2.056209		113.6
37	2294.378555		44.440918	SILUV	123.1
38	-267.747777		29.673499		125.9
39	557.248167		36.861702	SILUV	131.7
40	-783.213643		-0.938224		131.3
41	-14802.205529		16.206383		129.7
42	828.039709		43.221788	SILUV	129.1
43	-324.649154		0.998849		128.8
44	206.870457		45.792196	SILUV	109.6
45	-1913.727624		0.997376		104.5
46	81.421622		39.892459	SILUV	70.6
47	171.051496		1.070665		60.3
48	81.435251		36.484505	CAFUV	48.6
49	0.000000		3.000000	H2O	21.1
50	0.000000				16.5

TABLE 38A

(j344p)					
Aspherical Constants					
Surface					
	3	8	17	19	21
K	0	0	0	0	-2.35919
C1	-4.239547E-08	1.776408E-07	-3.517097E-08	-2.260275E-08	-3.531314E-08
C2	-3.439882E-12	-7.365374E-12	-1.680998E-12	1.477964E-12	5.754980E-13
C3	2.585420E-17	6.010661E-16	1.988836E-16	-5.557313E-17	-1.422154E-17
C4	-7.398192E-21	3.465765E-20	-8.317822E-21	-1.521633E-21	3.469778E-22
C5	2.490541E-24	-1.352374E-23	1.490936E-25	2.529206E-25	-6.366916E-27
C6	-1.543807E-28	7.789367E-28	9.086464E-29	-2.473128E-29	6.303151E-32
Surface					
	22	26	34	35	37
K	-2.55041	0	0	0	0
C1	5.763867E-08	-9.608615E-08	1.305280E-08	-5.677213E-08	3.512847E-09

TABLE 38A-continued

(j344p)					
Aspherical Constants					
C2	-8.648037E-13	4.888828E-12	5.858393E-13	1.460926E-12	-4.457077E-13
C3	3.811912E-17	-1.061062E-16	-2.240057E-17	7.309271E-17	-9.211061E-17
C4	-1.031346E-21	2.226871E-21	1.299691E-21	-7.691388E-21	7.360949E-21
C5	2.586799E-26	6.374143E-26	1.071950E-25	4.906816E-25	-3.041901E-25
C6	-2.333304E-31	-5.123581E-30	-1.228055E-29	-1.882267E-29	6.008115E-30

Surface		
	42	45
K	0	0
C1	-2.753413E-08	-2.014104E-08
C2	-1.731330E-13	3.259304E-12
C3	6.979195E-17	-1.414937E-16
C4	-2.163794E-21	5.867152E-21
C5	9.215216E-27	-1.748151E-25
C6	2.896055E-31	3.188929E-30

20

TABLE 39

(dave 040421)					
Surface	Radius	Asphere	Thickness	Material	$\frac{1}{2}$ Diam-eter
0	0.000000		40.000000		68.0
1	146.623761	AS	35.648639	SIO2V	84.3
2	-262.402199	AS	11.489893		86.4
3	-1418.271111	AS	55.535686	SIO2V	89.1
4	-149.803131		80.058956		92.8
5	-316.127680		-80.058956	REFL	66.8
6	-149.803131		-55.535686	SIO2V	77.9
7	-1418.271111		-11.489893		77.7
8	-262.402199		11.489893	REFL	78.4
9	-1418.271111		55.535686	SIO2V	88.5
10	-149.803131		90.058608		97.6
11	-318.170858	AS	42.027645	SIO2V	125.7
12	-174.217513		221.335808		130.9
13	-245.648700	AS	-201.335981	REFL	202.8
14	114.970031	AS	241.335931	REFL	93.2
15	372.783567	AS	46.864614	SIO2V	124.6
16	-819.903755		1.038628		123.6
17	177.861341		41.772805	SIO2V	112.5
18	341.365208		37.021407		104.9
19	-466.562113		12.000000	SIO2V	100.5
20	162.712763		42.079202		91.1
21	-370.098539		12.000000	SIO2V	91.3
22	462.418362		26.721285		96.0
23	-356.944827		27.234109	SIO2V	97.2

TABLE 39-continued

(dave 040421)					
Surface	Radius	Asphere	Thickness	Material	$\frac{1}{2}$ Diam-eter
24	-176.415718		1.000000		100.3
25	250.680892	AS	35.225819	SIO2V	109.0
26	-1151.380195		1.000000		108.8
27	400.524336		38.251924	SIO2V	107.1
28	-405.535651		31.160614		105.6
29	-149.637246		50.218339	SIO2V	104.4
30	-384.493074	AS	30.129631		114.6
31	0.000000		-29.129631		116.2
32	266.421209		50.004341	SIO2V	116.1
33	-466.737916		1.000000		115.2
34	142.958212		42.562558	SIO2V	102.2
35	432.609562	AS	0.098646		97.2
36	114.421108		32.582267	SIO2V	82.2
37	573.116962	AS	1.000000		76.7
38	60.777409		26.925305	SIO2V	52.9
39	76.682879		1.000000		41.9
40	70.399871		26.141931	CAF2V193	40.0
41	0.000000		3.000000	H2OV193	21.6
42	0		0		17.0

TABLE 39A

(dave 040421)					
Aspherical Constants					
Surface					
	1	2	3	11	13
K	0	0	0	0	0
C1	-3.341087E-07	8.388602E-08	3.429680E-08	3.116059E-09	3.046218E-09
C2	-2.505072E-12	-1.111052E-11	-9.182012E-12	4.201540E-13	4.170047E-14
C3	2.943082E-15	1.569768E-15	8.908974E-16	-8.967249E-17	3.681161E-19
C4	-4.955011E-19	-1.841754E-19	-1.039175E-19	4.467021E-21	2.802579E-23
C5	4.666851E-23	1.342877E-23	7.467060E-24	-1.240183E-25	-1.004802E-27
C6	-1.905456E-27	-4.061739E-28	-2.463306E-28	-3.737311E-31	3.611732E-32
C7					-6.507196E-37
C8					6.094959E-42

TABLE 39A-continued

(dave 040421) Aspherical Constants						
Surface						
	14	15	25	30	35	37
K	0	0	0	0	0	0
C1	-1.471452E-07	1.493626E-09	-2.761928E-08	3.891658E-09	8.202081E-10	1.252989E-07
C2	3.389142E-12	7.786239E-13	1.065077E-13	-2.344148E-13	-6.269685E-13	2.533320E-12
C3	-1.091618E-15	3.130190E-17	8.399310E-18	1.511118E-17	-2.459088E-16	1.123761E-16
C4	1.594470E-19	2.199868E-22	-2.005406E-21	-1.816247E-21	5.806198E-20	-1.266332E-19
C5	-2.248477E-23	-1.132529E-25	1.619754E-25	3.834331E-26	-3.997034E-24	1.618688E-23
C6	1.655691E-27	2.738900E-30	-8.094709E-30	5.510731E-31	1.041043E-28	-8.614797E-28
C7	-5.527960E-32					
C8	-3.066052E-37					

TABLE 40

20

TABLE 40-continued

(d125i9)						(d125i9)					
Surface	Radius	Asphere	Thickness	Material	$\frac{1}{2}$ Diameter	Surface	Radius	Asphere	Thickness	Material	$\frac{1}{2}$ Diameter
0	0.000000		31.999820		72.0	25	30		402.440360		26.948978
1	1121.871530	AS	22.353990	SIO2V	81.6	31	31		1784.180000		14.999955
2	-593.507575		151.330057		83.2	32	32		215.162499		22.977434
3	-276.701090		-150.330068	REFL	99.4	33	33		-1182.190098		22.085678
4	-1841.732700		158.991136	REFL	58.1	34	34		-212.011934		1.511427
5	-1993.161426		66.359854	SIO2V	129.7	35	35		-2234.326431	AS	16.015583
6	-226.138813		0.999989		137.1	36	36		102.656630		55.587588
7	320.967306		58.008492	SIO2V	147.2	37	37		227.255721		75.569686
8	-521.971452	AS	138.103093		146.7	38	38		-317.233998		1.001303
9	1018.489753	AS	33.863171	SIO2V	132.4	39	39		1810.772356	AS	34.492120
10	-836.147368		169.056435		131.1	40	40		-251.541624		3.237774
11	-150.333251		22.332601	SIO2V	98.2	41	41		0.000000		-2.238080
12	-264.622066		19.637756		104.6	42	42		312.037351		16.355638
13	-642.439229		-19.637756	REFL	105.6	43	43		1101.731550	AS	0.999509
14	-264.622066		-22.332601	SIO2V	96.6	44	44		373.203773		35.331514
15	-150.333251		-169.056435		86.0	45	45		-352.262575		0.999305
16	-836.147368		-33.863171	SIO2V	72.6	46	46		800.952563		34.674551
17	1018.489753	AS	-94.088120		78.6	47	47		-210.477645	AS	0.999728
18	196.895316		-14.999941	SIO2V	99.4	48	48		72.234210		29.521553
19	1436.276484		-28.015060		114.2	49	49		126.294484		7.096090
20	263.470635		28.015060	REFL	117.3	50	50		89.472175		36.272448
21	1436.276484		14.999941	SIO2V	115.4	51	51		0.000000		0.000000
22	196.895316		94.088120		104.5						
23	1018.489753	AS	33.863171	SIO2V	98.4						
24	-836.147368		232.111001		96.3						
25	-203.114130	AS	20.739811	SIO2V	89.7						
26	-179.567740		1.000292		94.4						
27	214.374385		45.853859	SIO2V	107.3						
28	-685.859253	AS	14.406908		106.3						
29	155.448944		34.186529	SIO2V	99.0						

TABLE 40A

(d125i9) Aspherical Constants					
Surface					
	1	8	9	17	23
K	0	0	0	0	0
C1	-6.489547E-09	1.779063E-08	-2.537260E-09	-2.537260E-09	-2.537260E-09
C2	2.573979E-12	-1.318309E-13	8.794118E-14	8.794118E-14	8.794118E-14
C3	-6.945437E-18	1.871976E-18	1.370489E-18	1.370489E-18	1.370489E-18
C4	-9.856064E-22	-2.538137E-23	2.480376E-23	2.480376E-23	2.480376E-23
C5	-5.398838E-26	5.262554E-28	3.221917E-28	3.221917E-28	3.221917E-28
C6	3.582736E-29	-4.568847E-33	-1.526882E-32	-1.526882E-32	-1.526882E-32

TABLE 40A-continued

(d125i9)						
Aspherical Constants						
Surface						
	25	28	35	39	43	47
K	0	0	0	0	0	0
C1	3.488627E-08	5.518741E-08	-1.889508E-07	-1.194060E-07	2.132675E-08	1.327564E-08
C2	-5.495753E-13	-1.879963E-12	-7.683963E-12	-3.708989E-13	3.335407E-12	8.696711E-13
C3	-6.723461E-17	-1.208371E-18	9.545139E-17	4.020986E-17	8.797815E-17	-1.462960E-16
C4	2.810907E-21	8.370662E-22	1.920197E-20	-1.082725E-20	-6.582985E-21	1.072413E-20
C5	-1.827899E-25	-3.751988E-26	1.709381E-24	3.369011E-26	-4.306562E-26	-5.792663E-25
C6	4.402454E-30	1.768617E-30	-4.887431E-30	1.763283E-29	1.609953E-29	7.946613E-30

TABLE 41

FIG.	NA	Y'	ZN _L	N _{op}	D _{max}	COMP1	COMP2	COMP3
4	1.10	16.25	17	3	201.5	10.25	174.21	58.07
7	1.10	16.25	17	3	220.9	11.23	190.99	63.66
8	1.15	16.25	17	3	220.1	10.24	174.11	58.04
16	1.20	16.25	20	3	219.7	9.39	187.78	62.59
17	1.20	16.25	21	3	235.5	10.06	211.35	70.45
19	1.20	16.25	20	3	263.9	11.28	225.56	75.19
20	1.20	16.00	19	3	306.5	13.30	252.76	84.25
21	1.20	16.17	20	3	240.6	10.33	206.66	68.89
22	1.20	16.25	19	3	249.3	10.65	202.42	67.47
23	1.20	16.17	18	3	264.2	11.35	204.24	68.08
27	1.20	16.50	23	3	269.9	11.36	261.27	87.09
28	1.20	16.50	23	3	229.4	9.65	222.06	74.02
30	1.20	16.50	21	3	266.1	11.20	235.19	78.40
31	1.20	16.50	20	3	272.6	11.47	229.46	76.49
32	1.20	16.50	20	3	272.3	11.46	229.21	76.40
34	1.20	16.50	22	3	241.0	10.14	223.15	74.38
36	1.20	16.50	23	3	278.6	11.73	269.69	89.90
37	1.20	16.50	23	3	250.2	10.53	242.20	80.73
38	1.20	16.50	23	3	263.4	11.09	254.97	84.99
39	1.20	17.00	16	3	260.0	10.62	169.93	56.64
40	1.05	18.00	19	3	294.0	14.81	281.48	93.83

What is claimed is:

1. A catadioptric projection objective for imaging a pattern provided in an object plane of the projection objective onto an image plane of the projection objective comprising:
 - a first objective part for imaging the pattern provided in the object plane into a first intermediate image;
 - a second objective part for imaging the first intermediate image into a second intermediate image;
 - a third objective part for imaging the second intermediate image onto the image plane;
 wherein a first concave mirror having a first continuous mirror surface and at least one second concave mirror having a second continuous mirror surface are arranged upstream of the second intermediate image; pupil surfaces are formed between the object plane and the first intermediate image, between the first and the second intermediate image and between the second intermediate image and the image plane; and all concave mirrors are arranged optically remote from a pupil surface,
 - wherein the projection objective includes exactly two concave mirrors and exactly two intermediate images.
2. Projection objective according to claim 1, wherein all concave mirrors are arranged optically remote from a pupil surface at a position where a chief ray height exceeds a marginal ray height of the imaging process.
3. Projection objective according to claim 1, wherein the first objective part is a dioptric imaging system; the second

objective part includes the first and the second concave mirrors, the concave mirror surfaces of the concave mirrors facing each other and defining an intermirror space; wherein at least the first intermediate image is located geometrically within the intermirror space between the first concave mirror and the second concave mirror.

4. Projection objective according to claim 3, wherein both the first intermediate image and the second intermediate image are located geometrically within the intermirror space between the first concave mirror and the second concave mirror.

5. Projection objective according to claim 1, wherein the first objective part and the second objective part and the third objective part share a common straight optical axis.

6. Projection objective according to claim 1, wherein curvature surfaces of the first concave mirror and the second concave mirror have a common axis of rotational symmetry defining a catadioptric or catoptric part of the optical axis which is inclined at an angle to an object side part and an image side part of the optical axis.

7. Projection objective according to claim 1, wherein at least one mirror surface of a concave mirror is aspheric.

8. Projection objective according to claim 1, wherein the first objective part is a catadioptric objective part including a first of the concave mirrors and the second objective part is a catadioptric objective part including a second of the two concave mirrors.

9. Projection objective according to claim 1, wherein a mirror group defined by the first and the second concave mirror facing each other has a mirror group entry and a mirror group exit, the mirror group entry being positioned geometrically next to an edge of the second concave mirror facing the optical axis and the mirror group exit being positioned geometrically next to an edge of the first concave mirror facing the optical axis and wherein pupil surfaces of the projection objective are arranged in a vicinity of the mirror group entry and in a vicinity of the mirror group exit.

10. Projection objective according to claim 1, wherein the projection objective is designed such that radiation reflected from the first concave mirror crosses the optical axis prior to impinging on the second concave mirror.

11. Projection objective according to claim 1, wherein the first objective part is purely refractive, the second objective part is catoptric or catadioptric, and the third objective part is purely refractive.

12. Projection objective according to claim 1, wherein the projection objective includes no convex mirror.

13. Projection objective according to claim 1, wherein the first objective part is designed as an enlarging imaging system.

14. Projection objective according to claim 1, wherein the first objective part is designed as an enlarging imaging system having a magnification β_1 in the range $1 < |\beta_1| < 2.5$.

15. Projection objective according to claim 1, wherein the second objective part is designed as near unit magnification optical system.

16. Projection objective according to claim 15, wherein the second objective part is designed as a system having a magnification β_2 in the range $0.4 < |\beta_2| < 1.5$.

17. Projection objective according to claim 15, wherein the second objective part is designed as a system having a magnification β_2 in the range $0.9 < |\beta_2| < 1.1$.

18. Projection objective according to claim 1, wherein the third objective part has a reducing magnification β_3 wherein $|\beta_3| < 1$.

19. Projection objective according to claim 1, wherein the second intermediate image has a size larger than the image size.

20. Projection objective according to claim 1, wherein at least one of the first concave mirror and the second concave mirror is designed as a Mangin Mirror.

21. Projection objective according to claim 1, wherein at least one of the first concave mirror and the second concave mirror is designed as a front face mirror.

22. Projection objective according to claim 1, wherein at least one of the concave mirrors has an aspheric reflecting surface having an absolute value of curvature which decreases from an optical axis of the projection objective to the edge of the mirror in a radial direction.

23. Projection objective according to claim 1, wherein the projection objective includes no planar folding mirror.

24. Projection objective according to claim 1, wherein a maximum light beam height at the concave mirrors is less than 1.5 fold of the maximum light beam height within the third objective part.

25. Projection objective according to claim 1, wherein the diameter of the concave mirrors is less than 150% of the size of the first and the second intermediate image.

26. Projection objective according to claim 1, wherein all light beams within the projection objective are located within a space defined as a cylinder around the optical axis of said third objective part, extending from the object plane to the image plane and having a maximum radius of 1.5 fold of a maximum beam height within said third objective part.

27. Projection objective according to claim 1, wherein a maximum free diameter is 2.4 fold of a maximum beam height within said third objective part.

28. Projection objective according to claim 1, wherein between the radius R1 of the first concave mirror and the radius R2 of the second concave mirror the following relation: $0.7 < |R1/R2| < 1.3$ is satisfied.

29. Projection objective according to claim 1, wherein between the radius R1 of the first concave mirror and the radius R2 of the second concave mirror and the distance d on the optical axis between the two concave mirrors the relation: $0.7 < (|R1+R2|)/2/d < 1.3$ is satisfied.

30. Projection objective according to claim 1, wherein at least one lens having a free entry surface and a free exit surface is arranged within an intermirror space defined between the first and second concave mirror.

31. Projection objective according to claim 30, wherein the lens is a mirror-related lens arranged such that it is transited twice by the radiation passing to and from the concave mirror.

32. Projection objective according to claim 31, wherein the mirror-related lens is a negative lens.

33. Projection objective according to claim 31, wherein the mirror-related lens is a meniscus lens having negative refractive power and a sense of curvature similar to the sense of curvature of the concave mirror to which the mirror-related lens is assigned.

34. Projection objective according to claim 31, wherein the mirror-related lens is designed as a truncated lens being arranged mostly on the side of the optical axis where the associated concave mirror is situated.

35. Projection objective according to claim 1, wherein there is at least one lens arranged within an intermirror space defined between the first and second concave mirror, wherein the lens is transited three times by a light beam between the object plane and the image plane.

36. Projection objective according to claim 1, wherein the first concave mirror and the second concave mirror are designed to have essentially the same or exactly the same curvature surfaces.

37. Projection objective according to claim 1, wherein the first concave mirror and the second concave mirror are manufactured such that firstly a mirror blank for the first and second concave mirror is manufactured to obtain a desired concave shape of a mirror surface and that, afterwards, the mirror blank is separated into two truncated mirror used as the first and second concave mirror.

38. Projection objective according to claim 1, wherein the second objective part includes a first catadioptric sub-group consisting of the first concave mirror and a first mirror-related lens and a second catadioptric sub-group consisting of the second concave mirror and a second mirror-related lens, wherein the catadioptric sub-groups are designed essentially identically.

39. Projection objective according to claim 1, wherein concave surfaces of the two concave mirrors are aspheric.

40. Projection objective according to claim 1, wherein there is at least one lens arranged within an intermirror space defined between the concave mirrors, the at least one lens being positioned between an intermediate image and one of the two concave mirrors optically near the intermediate image; where at least one surface of the lens is aspheric.

41. Projection objective according to claim 40, wherein the aspheric surface of the lens is the surface facing the intermediate image.

42. Projection objective according to claim 1, wherein the first concave mirror has a curvature c_1 (in $[\text{mm}^{-1}]$) and the second concave mirror has a curvature c_2 (in $[\text{mm}^{-1}]$) and D (in [mm]) is a maximum diameter of a lens element of the third objective part and wherein the following condition is fulfilled: $1 < D/(|c_1+c_2|) \cdot 10^{-4} < 6$.

43. Projection objective according to claim 1, wherein at least one of the concave mirrors fulfills the condition: $p > 0.22R$ where $p = R - (R^2 - D^2/4)^{0.5}$, wherein R is the curvature radius and D is the diameter of the aspherical mirror surface.

44. Projection objective according to claim 43, wherein the condition $D < 1.3R$ is fulfilled.

45. Projection objective according to claim 1, wherein the projection objective is designed such that the first intermediate image is located geometrically within an intermirror space defined between the first and second concave mirror and the second intermediate image is arranged outside the intermirror space.

46. Projection objective according to claim 1, wherein the first and the second concave mirror are disposed on the same side of an optical axis of the projection objective.

47. Projection objective according to claim 1, wherein the first concave mirror and the second concave mirror are positioned at opposite sides of an optical axis of the projection objective.

48. Projection objective according to claim 1, wherein at least one lens is arranged outside an intermirror space defined between the first and second concave mirror between a mirror group defined by the first and second concave mirror and the second intermediate image.

49. Projection objective according to claim 1, wherein the projection objective includes at least one biaspherical lens having an aspheric entrance surface and an aspheric exit surface.

50. Projection objective according to claim 49, wherein at least one of the pupil surfaces is formed in the third objective part and wherein the biaspherical lens is arranged between the at least one pupil surface in the third objective part and the image plane.

51. Projection objective according to claim 1, wherein the first objective part includes at least one lens having a concave surface facing the image plane.

52. Projection objective according to claim 51, wherein the lens having a concave surface facing the image plane is a meniscus lens arranged between the object plane and a pupil surface of the first objective part.

53. Projection objective according to claim 1, wherein at least one of the pupil surfaces is formed in the first objective part and a first lens group is arranged between the object plane and the at least one pupil surface in the first objective part, wherein the first lens group includes in that sequence a positive lens, a negative lens and a positive lens, wherein the negative lens has a concave surface facing the image.

54. Projection objective according to claim 1, wherein a maximum diameter of optical elements of the second objective part is smaller or equal to a maximum diameter of lenses of the third objective part.

55. Projection objective according to claim 1, wherein at least one of the pupil surfaces is formed in the third objective part and at least one lens having negative refractive power arranged between the second intermediate image and the at least one pupil surface in the third objective part such that a shallow waist is defined in the beam path, wherein no negative lens is arranged between the waist and the image plane.

56. Projection objective according to claim 1, wherein the third objective part includes no more than two negative lenses.

57. Projection objective according to claim 1, wherein the projection objective has an image side numerical aperture $NA < 0.9$.

58. Projection objective according to claim 1, wherein the projection objective is designed as an immersion objective adapted with reference to aberrations such that an image side working distance between a last optical element and the image plane is filled up with an immersion medium with a refractive index substantially greater than 1.

59. Projection objective according to claim 1, wherein the projection objective has an image side numerical aperture $NA < 1.1$ when used in connection with an immersion medium.

60. Projection objective according to claim 1, wherein the projection objective is telecentric on both its object end and image end.

61. Projection objective according to claim 1, wherein the projection objective has an essentially homocentric entrance pupil.

62. Projection objective according to claim 1, wherein an aperture stop is provided in the first objective part.

63. Projection objective according to claim 1, wherein an aperture stop is provided in the second objective part.

64. Projection objective according to claim 1, wherein an aperture stop is provided in the third objective part.

65. Projection objective according to claim 1, wherein the projection objective is configured for use with ultraviolet light falling within a wavelength range extending from about 120 nm to about 260 nm.

66. Projection objective according to claim 1, wherein the first concave mirror has a first aspheric mirror surface and the second concave mirror has a second aspheric mirror surface, and wherein the first and second mirror surfaces have essentially the same or identical aspheric shape.

67. Projection objective according to claim 1, wherein at least one of the first and second concave mirrors has a mirror surface having a parabolic shape.

68. Projection objective according to claim 1, wherein the first objective part is purely refractive and has positive lenses only.

69. Projection objective according to claim 68, wherein a plate having essentially parallel plate surfaces is provided in addition to the positive lenses in the first objective part.

70. Projection objective according to claim 1, wherein a first lens element of the first objective part immediately following the object plane has an aspheric surface facing the object plane, wherein the aspheric surface is essentially flat having a local radius $R < 300$ mm at each point of the aspheric surface.

71. Projection objective according to claim 1, wherein all negative lenses are arranged optically remote from the pupil surfaces.

72. Projection objective according to claim 1, wherein a plurality of optical elements having at least one aspherical surface is provided, and wherein all aspheric surfaces have surface shapes which are free of inflection points.

73. Projection objective according to claim 1, wherein the projection objective has at least one optical element having an aspherical surface with a surface shape free of extremal points in an optically used area of the aspheric surface outside the optical axis, wherein an extremal point is defined by:

$$\frac{dp}{dh} = 0 \text{ and } \frac{d^2p}{dh^2} \neq 0$$

where parameter p represents a distance, measured parallel to the optical axis of an optical element, of a point at height h from the vertex of the surface.

74. Projection objective according to claim 73, wherein the aspheric surface is free of extremal point in an area including the optically utilized area defined by the optically used radius h_{opt} and going beyond that area up to a maximum height $h_{max} > h_{opt}$ where $h_{max} = h_{opt} + OR$ and where OR is at least 5 mm.

75. Projection objective according to claim 1, wherein a plurality of optical elements having at least one aspherical surface is provided, and wherein all aspheric surfaces have surface shapes which are free of extremal points outside the optical axis.

76. Projection objective according to claim 1, wherein aspheric surfaces having at least one extremal point are essentially flat across the entire optically utilized area.

101

77. Projection objective according to claim 1, having at least one aspheric surface having at least one extremal point, where the aspheric surface is essentially flat across the entire optically utilized area of the optical element such that the following condition holds for that aspheric surface: $|p(h)| < p_{max}$ where $p_{max} = 0.5$ mm.

78. A catadioptric projection objective for imaging a pattern provided in an object plane of the projection objective onto an image plane of the projection objective comprising:

a first, refractive objective part for imaging the pattern provided in the object plane into a first intermediate image;

a second, catadioptric or catoptric objective part for imaging the first intermediate image into a second intermediate image;

a third, refractive objective part for imaging the second intermediate image onto the image plane;

wherein the second objective part includes exactly one first concave mirror having a first continuous mirror surface and exactly one second concave mirror having a second continuous mirror surface, the concave mirror faces of the concave mirrors facing each other and defining an intermirror space;

wherein the first and the second intermediate image are located geometrically within the intermirror space between the first concave mirror and the second concave mirror.

79. A catadioptric projection objective for imaging a pattern provided in an object plane of the projection objective onto an image plane of the projection objective comprising:

a first objective part for imaging the pattern provided in the object plane into a first intermediate image;

a second objective part for imaging the first intermediate image into a second intermediate image;

a third objective part for imaging the second intermediate image onto the image plane;

wherein a first concave mirror having a first continuous mirror surface and at least one second concave mirror having a second continuous mirror surface are arranged upstream of the second intermediate image;

pupil surfaces are formed between the object plane and the first intermediate image, between the first and the second intermediate image and between the second intermediate image and the image plane; and

all concave mirrors are arranged optically remote from a pupil surface at a position where a chief ray height exceeds a marginal ray height of the imaging process.

80. A catadioptric projection objective for imaging a pattern provided in an object plane of the projection objective onto an image plane of the projection objective comprising:

a first objective part for imaging the pattern provided in the object plane into a first intermediate image;

a second objective part for imaging the first intermediate image into a second intermediate image;

a third objective part for imaging the second intermediate image onto the image plane;

wherein a first concave mirror having a first continuous mirror surface and at least one second concave mirror having a second continuous mirror surface are arranged upstream of the second intermediate image;

pupil surfaces are formed between the object plane and the first intermediate image, between the first and the second intermediate image and between the second intermediate image and the image plane;

102

all concave mirrors are arranged optically remote from a pupil surface; and

curvature surfaces of the first concave mirror and the at least one second concave mirror have a common axis of rotational symmetry defining a catadioptric or catoptric part of the optical axis which is inclined at an angle to an object side part and an image side part of the optical axis.

81. A catadioptric projection objective for imaging a pattern provided in an object plane of the projection objective onto an image plane of the projection objective comprising:

a first objective part for imaging the pattern provided in the object plane into a first intermediate image;

a second objective part for imaging the first intermediate image into a second intermediate image;

a third objective part for imaging the second intermediate image onto the image plane;

wherein a first concave mirror having a first continuous mirror surface and at least one second concave mirror having a second continuous mirror surface are arranged upstream of the second intermediate image;

pupil surfaces are formed between the object plane and the first intermediate image, between the first and the second intermediate image and between the second intermediate image and the image plane;

all concave mirrors are arranged optically remote from a pupil surface; and

the first objective part is purely refractive, the second objective part is catoptric or catadioptric, and the third objective part is purely refractive.

82. A catadioptric projection objective for imaging a pattern provided in an object plane of the projection objective onto an image plane of the projection objective comprising:

a first objective part for imaging the pattern provided in the object plane into a first intermediate image;

a second objective part for imaging the first intermediate image into a second intermediate image;

a third objective part for imaging the second intermediate image onto the image plane;

wherein a first concave mirror having a first continuous mirror surface and at least one second concave mirror having a second continuous mirror surface are arranged upstream of the second intermediate image;

pupil surfaces are formed between the object plane and the first intermediate image, between the first and the second intermediate image and between the second intermediate image and the image plane;

all concave mirrors are arranged optically remote from a pupil surface; and

the projection objective includes no convex mirror.

83. A catadioptric projection objective for imaging a pattern provided in an object plane of the projection objective onto an image plane of the projection objective comprising:

a first objective part for imaging the pattern provided in the object plane into a first intermediate image;

a second objective part for imaging the first intermediate image into a second intermediate image;

a third objective part for imaging the second intermediate image onto the image plane;

wherein a first concave mirror having a first continuous mirror surface and at least one second concave mirror having a second continuous mirror surface are arranged upstream of the second intermediate image;

103

pupil surfaces are formed between the object plane and the first intermediate image, between the first and the second intermediate image and between the second intermediate image and the image plane;

all concave mirrors are arranged optically remote from a pupil surface; and

wherein the first objective part is designed as an enlarging imaging system having a magnification β_1 in the range $1 < |\beta_1| < 2.5$.

84. A catadioptric projection objective for imaging a pattern provided in an object plane of the projection objective onto an image plane of the projection objective comprising:

a first objective part for imaging the pattern provided in the object plane into a first intermediate image;

a second objective part for imaging the first intermediate image into a second intermediate image;

a third objective part for imaging the second intermediate image onto the image plane;

wherein a first concave mirror having a first continuous mirror surface and at least one second concave mirror having a second continuous mirror surface are arranged upstream of the second intermediate image;

pupil surfaces are formed between the object plane and the first intermediate image, between the first and the second intermediate image and between the second intermediate image and the image plane;

all concave mirrors are arranged optically remote from a pupil surface; and

the second objective part is designed as near unit magnification optical system.

85. A catadioptric projection objective for imaging a pattern provided in an object plane of the projection objective onto an image plane of the projection objective comprising:

a first objective part for imaging the pattern provided in the object plane into a first intermediate image;

a second objective part for imaging the first intermediate image into a second intermediate image;

a third objective part for imaging the second intermediate image onto the image plane;

wherein a first concave mirror having a first continuous mirror surface and at least one second concave mirror having a second continuous mirror surface are arranged upstream of the second intermediate image;

pupil surfaces are formed between the object plane and the first intermediate image, between the first and the second intermediate image and between the second intermediate image and the image plane;

all concave mirrors are arranged optically remote from a pupil surface; and at least one of the first concave mirror and the at least one second concave mirror is designed as a Mangin Mirror.

86. A catadioptric projection objective for imaging a pattern provided in an object plane of the projection objective onto an image plane of the projection objective comprising:

a first objective part for imaging the pattern provided in the object plane into a first intermediate image;

a second objective part for imaging the first intermediate image into a second intermediate image;

a third objective part for imaging the second intermediate image onto the image plane;

wherein a first concave mirror having a first continuous mirror surface and at least one second concave mirror having a second continuous mirror surface are arranged upstream of the second intermediate image;

104

pupil surfaces are formed between the object plane and the first intermediate image, between the first and the second intermediate image and between the second intermediate image and the image plane;

all concave mirrors are arranged optically remote from a pupil surface;

a maximum light beam height at the concave mirrors is less than 1.5 fold of the maximum light beam height within the third objective part.

87. A catadioptric projection objective for imaging a pattern provided in an object plane of the projection objective onto an image plane of the projection objective comprising:

a first objective part for imaging the pattern provided in the object plane into a first intermediate image;

a second objective part for imaging the first intermediate image into a second intermediate image;

a third objective part for imaging the second intermediate image onto the image plane;

wherein a first concave mirror having a first continuous mirror surface and at least one second concave mirror having a second continuous mirror surface are arranged upstream of the second intermediate image;

pupil surfaces are formed between the object plane and the first intermediate image, between the first and the second intermediate image and between the second intermediate image and the image plane;

all concave mirrors are arranged optically remote from the pupil surfaces; and

all light beams within the projection objective are located within a space defined as a cylinder around the optical axis of the third objective part, extending from the object plane to the image plane and having a maximum radius of 1.5 fold of a maximum beam height within the third objective part.

88. A catadioptric projection objective for imaging a pattern provided in an object plane of the projection objective onto an image plane of the projection objective comprising:

a first objective part for imaging the pattern provided in the object plane into a first intermediate image;

a second objective part for imaging the first intermediate image into a second intermediate image;

a third objective part for imaging the second intermediate image onto the image plane;

wherein a first concave mirror having a first continuous mirror surface and at least one second concave mirror having a second continuous mirror surface are arranged upstream of the second intermediate image;

pupil surfaces are formed between the object plane and the first intermediate image, between the first and the second intermediate image and between the second intermediate image and the image plane;

all concave mirrors are arranged optically remote from a pupil surface; and

the first concave mirror has a radius of curvature R_1 , one of the at least one second concave mirrors has a radius of curvature R_2 , and there is a distance d on the optical axis between the two concave mirrors such that the relation: $0.7 < (|R_1| + |R_2|) / 2 / d < 1.3$ is satisfied.

89. A catadioptric projection objective for imaging a pattern provided in an object plane of the projection objective onto an image plane of the projection objective comprising:

a first objective part for imaging the pattern provided in the object plane into a first intermediate image;

105

a second objective part for imaging the first intermediate image into a second intermediate image;
 a third objective part for imaging the second intermediate image onto the image plane;

wherein a first concave mirror having a first continuous mirror surface and at least one second concave mirror having a second continuous mirror surface are arranged upstream of the second intermediate image;

pupil surfaces are formed between the object plane and the first intermediate image, between the first and the second intermediate image and between the second intermediate image and the image plane;

all concave mirrors are arranged optically remote from a pupil surface; and

at least one lens having a free entry surface and a free exit surface is arranged within an intermirror space defined between the first concave mirror and the at least one second concave mirror.

90. A catadioptric projection objective for imaging a pattern provided in an object plane of the projection objective onto an image plane of the projection objective comprising:

a first objective part for imaging the pattern provided in the object plane into a first intermediate image;

a second objective part for imaging the first intermediate image into a second intermediate image;

a third objective part for imaging the second intermediate image onto the image plane;

wherein a first concave mirror having a first continuous mirror surface and at least one second concave mirror having a second continuous mirror surface are arranged upstream of the second intermediate image;

pupil surfaces are formed between the object plane and the first intermediate image, between the first and the second intermediate image and between the second intermediate image and the image plane;

all concave mirrors are arranged optically remote from a pupil surface; and

at least one lens arranged within an intermirror space defined between the first and a second concave mirror, wherein the lens is transited three times by a light beam between the object plane and the image plane.

91. A catadioptric projection objective for imaging a pattern provided in an object plane of the projection objective onto an image plane of the projection objective comprising:

a first objective part for imaging the pattern provided in the object plane into a first intermediate image;

a second objective part for imaging the first intermediate image into a second intermediate image;

a third objective part for imaging the second intermediate image onto the image plane;

wherein a first concave mirror having a first continuous mirror surface and at least one second concave mirror having a second continuous mirror surface are arranged upstream of the second intermediate image;

pupil surfaces are formed between the object plane and the first intermediate image, between the first and the second intermediate image and between the second intermediate image and the image plane;

all concave mirrors are arranged optically remote from a pupil surface; and

the first concave mirror and a second concave mirror are manufactured such that firstly a mirror blank for the first and a second concave mirror is manufactured to obtain a desired concave shape of a mirror surface and

106

that, afterwards, the mirror blank is separated into two truncated mirror used as the first and a second concave mirror.

92. A catadioptric projection objective for imaging a pattern provided in an object plane of the projection objective onto an image plane of the projection objective comprising:

a first objective part for imaging the pattern provided in the object plane into a first intermediate image;

a second objective part for imaging the first intermediate image into a second intermediate image;

a third objective part for imaging the second intermediate image onto the image plane;

wherein a first concave mirror having a first continuous mirror surface and at least one second concave mirror having a second continuous mirror surface are arranged upstream of the second intermediate image;

pupil surfaces are formed between the object plane and the first intermediate image, between the first and the second intermediate image and between the second intermediate image and the image plane;

all concave mirrors are arranged optically remote from a pupil surface; and

the second objective part includes a first catadioptric sub-group consisting of the first concave mirror and a first mirror-related lens and a second catadioptric sub-group consisting of a second concave mirror and a second mirror-related lens, wherein the catadioptric sub-groups are designed essentially identically.

93. A catadioptric projection objective for imaging a pattern provided in an object plane of the projection objective onto an image plane of the projection objective comprising:

a first objective part for imaging the pattern provided in the object plane into a first intermediate image;

a second objective part for imaging the first intermediate image into a second intermediate image;

a third objective part for imaging the second intermediate image onto the image plane;

wherein a first concave mirror having a first continuous mirror surface and at least one second concave mirror having a second continuous mirror surface are arranged upstream of the second intermediate image;

pupil surfaces are formed between the object plane and the first intermediate image, between the first and the second intermediate image and between the second intermediate image and the image plane;

all concave mirrors are arranged optically remote from a pupil surface; and

there is at least one lens arranged within an intermirror space defined between the first and a second concave mirror between an intermediate image and an associated concave mirror optically near the intermediate image, where at least one surface of the lens is aspheric.

94. A catadioptric projection objective for imaging a pattern provided in an object plane of the projection objective onto an image plane of the projection objective comprising:

a first objective part for imaging the pattern provided in the object plane into a first intermediate image;

a second objective part for imaging the first intermediate image into a second intermediate image;

a third objective part for imaging the second intermediate image onto the image plane;

wherein a first concave mirror having a first continuous mirror surface and at least one second concave mirror

107

having a second continuous mirror surface are arranged upstream of the second intermediate image;

pupil surfaces are formed between the object plane and the first intermediate image, between the first and the second intermediate image and between the second intermediate image and the image plane;

all concave mirrors are arranged optically remote from a pupil surface; and

the projection objective is designed such that the first intermediate image is located geometrically within an intermirror space defined between the first and a second concave mirror and the second intermediate image is arranged outside the intermirror space.

95. A catadioptric projection objective for imaging a pattern provided in an object plane of the projection objective onto an image plane of the projection objective comprising:

a first objective part for imaging the pattern provided in the object plane into a first intermediate image;

a second objective part for imaging the first intermediate image into a second intermediate image;

a third objective part for imaging the second intermediate image onto the image plane; wherein a first concave mirror having a first continuous mirror surface and at least one second concave mirror having a second continuous mirror surface are arranged upstream of the second intermediate image;

pupil surfaces are formed between the object plane and the first intermediate image, between the first and the second intermediate image and between the second intermediate image and the image plane;

all concave mirrors are arranged optically remote from the pupil surfaces; and

the first and the at least one second concave mirror are disposed on the same side of an optical axis of the projection objective.

96. A catadioptric projection objective for imaging a pattern provided in an object plane of the projection objective onto an image plane of the projection objective comprising:

a first objective part for imaging the pattern provided in the object plane into a first intermediate image;

a second objective part for imaging the first intermediate image into a second intermediate image;

a third objective part for imaging the second intermediate image onto the image plane;

wherein a first concave mirror having a first continuous mirror surface and at least one second concave mirror having a second continuous mirror surface are arranged upstream of the second intermediate image;

pupil surfaces are formed between the object plane and the first intermediate image, between the first and the second intermediate image and between the second intermediate image and the image plane;

all concave mirrors are arranged optically remote from a pupil surface; and

at least one lens is arranged outside an intermirror space defined between the first and a second concave mirror between a mirror group defined by the first and the at least one second concave mirror and the second intermediate image.

97. A catadioptric projection objective for imaging a pattern provided in an object plane of the projection objective onto an image plane of the projection objective comprising:

a first objective part for imaging the pattern provided in the object plane into a first intermediate image;

108

a second objective part for imaging the first intermediate image into a second intermediate image;

a third objective part for imaging the second intermediate image onto the image plane;

wherein a first concave mirror having a first continuous mirror surface and at least one second concave mirror having a second continuous mirror surface are arranged upstream of the second intermediate image;

pupil surfaces are formed between the object plane and the first intermediate image, between the first and the second intermediate image and between the second intermediate image and the image plane;

all concave mirrors are arranged optically remote from a pupil surface; and

the projection objective includes at least one biaspherical lens having an aspheric entrance surface and an aspheric exit surface.

98. A catadioptric projection objective for imaging a pattern provided in an object plane of the projection objective onto an image plane of the projection objective comprising:

a first objective part for imaging the pattern provided in the object plane into a first intermediate image;

a second objective part for imaging the first intermediate image into a second intermediate image;

a third objective part for imaging the second intermediate image onto the image plane;

wherein a first concave mirror having a first continuous mirror surface and at least one second concave mirror having a second continuous mirror surface are arranged upstream of the second intermediate image;

pupil surfaces are formed between the object plane and the first intermediate image, between the first and the second intermediate image and between the second intermediate image and the image plane;

all concave mirrors are arranged optically remote from a pupil surface; and

the first objective part includes at least one lens having a concave surface facing the image plane.

99. A catadioptric projection objective for imaging a pattern provided in an object plane of the projection objective onto an image plane of the projection objective comprising:

a first objective part for imaging the pattern provided in the object plane into a first intermediate image;

a second objective part for imaging the first intermediate image into a second intermediate image;

a third objective part for imaging the second intermediate image onto the image plane;

wherein a first concave mirror having a first continuous mirror surface and at least one second concave mirror having a second continuous mirror surface are arranged upstream of the second intermediate image;

pupil surfaces are formed between the object plane and the first intermediate image, between the first and the second intermediate image and between the second intermediate image and the image plane;

all concave mirrors are arranged optically remote from pupil surfaces; and

the first objective part includes one of the pupil surfaces and a first lens group arranged between the object plane and the pupil surface of the first objective part, wherein the first lens group includes in that sequence a positive lens, a negative lens and a positive lens, wherein the negative lens has a concave surface facing the image.

109

100. A catadioptric projection objective for imaging a pattern provided in an object plane of the projection objective onto an image plane of the projection objective comprising:

- a first objective part for imaging the pattern provided in the object plane into a first intermediate image;
- a second objective part for imaging the first intermediate image into a second intermediate image;
- a third objective part for imaging the second intermediate image onto the image plane;
- wherein a first concave mirror having a first continuous mirror surface and at least one second concave mirror having a second continuous mirror surface are arranged upstream of the second intermediate image;
- pupil surfaces are formed between the object plane and the first intermediate image, between the first and the second intermediate image and between the second intermediate image and the image plane;
- all concave mirrors are arranged optically remote from a pupil surface; and
- a maximum diameter of optical elements of the second objective part is smaller or equal to a maximum diameter of lenses of the third objective part.

101. A catadioptric projection objective for imaging a pattern provided in an object plane of the projection objective onto an image plane of the projection objective comprising:

- a first objective part for imaging the pattern provided in the object plane into a first intermediate image;
- a second objective part for imaging the first intermediate image into a second intermediate image;
- a third objective part for imaging the second intermediate image onto the image plane;
- wherein a first concave mirror having a first continuous mirror surface and at least one second concave mirror having a second continuous mirror surface are arranged upstream of the second intermediate image;
- pupil surfaces are formed between the object plane and the first intermediate image, between the first and the second intermediate image and between the second intermediate image and the image plane;
- all concave mirrors are arranged optically remote from a pupil surface; and
- the third objective part includes no more than two negative lenses.

102. A catadioptric projection objective for imaging a pattern provided in an object plane of the projection objective onto an image plane of the projection objective comprising:

- a first objective part for imaging the pattern provided in the object plane into a first intermediate image;
- a second objective part for imaging the first intermediate image into a second intermediate image;
- a third objective part for imaging the second intermediate image onto the image plane;
- wherein a first concave mirror having a first continuous mirror surface and at least one second concave mirror having a second continuous mirror surface are arranged upstream of the second intermediate image;
- pupil surfaces are formed between the object plane and the first intermediate image, between the first and the second intermediate image and between the second intermediate image and the image plane;
- all concave mirrors are arranged optically remote from a pupil surface; and
- an aperture stop is provided in the first objective part.

110

103. A catadioptric projection objective for imaging a pattern provided in an object plane of the projection objective onto an image plane of the projection objective comprising:

- a first objective part for imaging the pattern provided in the object plane into a first intermediate image;
- a second objective part for imaging the first intermediate image into a second intermediate image;
- a third objective part for imaging the second intermediate image onto the image plane;
- wherein a first concave mirror having a first continuous mirror surface and at least one second concave mirror having a second continuous mirror surface are arranged upstream of the second intermediate image;
- pupil surfaces are formed between the object plane and the first intermediate image, between the first and the second intermediate image and between the second intermediate image and the image plane;
- all concave mirrors are arranged optically remote from a pupil surface; and
- an aperture stop is provided in the second objective part.

104. A catadioptric projection objective for imaging a pattern provided in an object plane of the projection objective onto an image plane of the projection objective comprising:

- a first objective part for imaging the pattern provided in the object plane into a first intermediate image;
- a second objective part for imaging the first intermediate image into a second intermediate image;
- a third objective part for imaging the second intermediate image onto the image plane;
- wherein a first concave mirror having a first continuous mirror surface and at least one second concave mirror having a second continuous mirror surface are arranged upstream of the second intermediate image;
- pupil surfaces are formed between the object plane and the first intermediate image, between the first and the second intermediate image and between the second intermediate image and the image plane;
- all concave mirrors are arranged optically remote from a pupil surface; and
- the first concave mirror has a first aspheric mirror surface and the at least one second concave mirror has a second aspheric mirror surface, and wherein the first and second mirror surfaces have essentially the same or identical aspheric shape.

105. A catadioptric projection objective for imaging a pattern provided in an object plane of the projection objective onto an image plane of the projection objective comprising:

- a first objective part for imaging the pattern provided in the object plane into a first intermediate image;
- a second objective part for imaging the first intermediate image into a second intermediate image;
- a third objective part for imaging the second intermediate image onto the image plane;
- wherein a first concave mirror having a first continuous mirror surface and at least one second concave mirror having a second continuous mirror surface are arranged upstream of the second intermediate image;
- pupil surfaces are formed between the object plane and the first intermediate image, between the first and the second intermediate image and between the second intermediate image and the image plane;

111

all concave mirrors are arranged optically remote from a pupil surface; and
 at least one of the first and the at least one second concave mirrors has a mirror surface having a parabolic shape.

106. A catadioptric projection objective for imaging a pattern provided in an object plane of the projection objective onto an image plane of the projection objective comprising:

- a first objective part for imaging the pattern provided in the object plane into a first intermediate image;
- a second objective part for imaging the first intermediate image into a second intermediate image;
- a third objective part for imaging the second intermediate image onto the image plane;
- wherein a first concave mirror having a first continuous mirror surface and at least one second concave mirror having a second continuous mirror surface are arranged upstream of the second intermediate image;
- pupil surfaces are formed between the object plane and the first intermediate image, between the first and the second intermediate image and between the second intermediate image and the image plane;
- all concave mirrors are arranged optically remote from a pupil surface; and
- the first objective part is purely refractive and has positive lenses only.

107. A catadioptric projection objective for imaging a pattern provided in an object plane of the projection objective onto an image plane of the projection objective comprising:

- a first objective part for imaging the pattern provided in the object plane into a first intermediate image;
- a second objective part for imaging the first intermediate image into a second intermediate image;
- a third objective part for imaging the second intermediate image onto the image plane;
- wherein a first concave mirror having a first continuous mirror surface and at least one second concave mirror having a second continuous mirror surface are arranged upstream of the second intermediate image;
- pupil surfaces are formed between the object plane and the first intermediate image, between the first and the second intermediate image and between the second intermediate image and the image plane;
- all concave mirrors are arranged optically remote from a pupil surface; and
- the projection objective, has at least one aspheric surface having at least one extremal point, where the aspheric surface is essentially flat across the entire optically utilized area of the optical element such that the following condition holds for that aspheric surface: $|p(h)| < p_{max}$ where $p_{max} = 0.5$ mm.

108. A catadioptric projection objective for imaging a pattern provided in an object plane of the projection objective onto an image plane of the projection objective comprising:

112

a first objective part for imaging the pattern provided in the object plane into a first intermediate image;

a second objective part for imaging the first intermediate image into a second intermediate image;

a third objective part for imaging the second intermediate image onto the image plane;

wherein a first concave mirror having a first continuous mirror surface and at least one second concave mirror having a second continuous mirror surface are arranged upstream of the second intermediate image;

pupil surfaces are formed between the object plane and the first intermediate image, between the first and the second intermediate image and between the second intermediate image and the image plane;

all concave mirrors are arranged optically remote from pupil surfaces; and

the first objective part includes the first concave mirror and at least one additional mirror having a curved mirror surface, where the curved mirror surfaces of the concave mirror and the additional mirror are facing each other, and the additional mirror is positioned optically near a one of the pupil surfaces.

109. A catadioptric projection objective for imaging a pattern provided in an object plane of the projection objective onto an image plane of the projection objective comprising:

a first objective part for imaging the pattern provided in the object plane into a first intermediate image;

a second objective part for imaging the first intermediate image into a second intermediate image;

a third objective part for imaging the second intermediate image onto the image plane;

pupil surfaces are formed between the object plane and the first intermediate image, between the first and the second intermediate image and between the second intermediate image and the image plane; and

the projection objective has exactly three concave mirrors arranged optically remote from a pupil surface, wherein a first concave mirror having a first continuous mirror surface and at least one second concave mirror having a second continuous mirror surface are arranged upstream of the second intermediate image; and

the first objective part includes a concave mirror and at least one additional mirror having a curved mirror surface, wherein the curved mirror surfaces of the concave mirror and the additional mirror are facing each other.

* * * * *

UNITED STATES PATENT AND TRADEMARK OFFICE
CERTIFICATE OF CORRECTION

PATENT NO. : 7,385,756 B2
APPLICATION NO. : 11/035103
DATED : June 10, 2008
INVENTOR(S) : Shafer et al.

Page 1 of 4

It is certified that error appears in the above-identified patent and that said Letters Patent is hereby corrected as shown below:

On page 2, in column 2 Item [56], under “Foreign Patent Documents”, line 10, after “1318425 B1” delete “6/2003” and insert -- 3/2006 --, therefor.

On page 2, in column 2 Item [56], under “Foreign Patent Documents”, line 12, below “EP 1336 887 8/2003” delete “EP 1336 887 8/2003 A1”.

On page 3, in column 1 Item [56], under “Foreign Patent Documents”, line 3, below “WO94/06047 3/1994” delete “WO94/06047 A1 3/1994”.

On page 3, in column 2, Item [56], under “Other Publications”, line 6, delete “No. 13” and insert -- No. 14 --, therefor.

In column 6, line 60, delete “focussing” and insert -- focusing --, therefor.

In column 7, line 10, delete “bundel” and insert -- bundle --, therefor.

In column 7, line 64, delete “magnification” and insert -- magnification --, therefor.

In column 13, line 44, delete “(meridonal)” and insert -- (meridional) --, therefor.

In column 13, line 55, delete “ $|p(h)| < P_{\max}$,” and insert -- $|p(h)| < P_{\max}$, --, therefor.

In column 14, line 7, delete “ist” and insert -- is --, therefor.

In column 19, line 39, delete “~50 mm.” and insert -- ·50 mm. --, therefor.

In column 20, line 66, delete “An” and insert -- A --, therefor.

In column 21, line 1, delete “schematric” and insert -- schematic --, therefor.

In column 25, line 31, delete “magnification” and insert -- magnification --, therefor.

In column 26, line 3, delete “arran-ged” and insert -- arranged --, therefor.

In column 27, line 25, delete “ $(R-D^2-D^2/4)$ ” and insert -- $(R^2-D^2-D^2/4)$ --, therefor.

UNITED STATES PATENT AND TRADEMARK OFFICE
CERTIFICATE OF CORRECTION

PATENT NO. : 7,385,756 B2
APPLICATION NO. : 11/035103
DATED : June 10, 2008
INVENTOR(S) : Shafer et al.

Page 2 of 4

It is certified that error appears in the above-identified patent and that said Letters Patent is hereby corrected as shown below:

In column 27, line 51, delete “catoptic” and insert -- catoptric --, therefor.

In column 31, line 28, delete “1502.” and insert -- 1502, --, therefor.

In column 31, line 31, delete “1602.” and insert -- 1602, --, therefor.

In column 31, line 37, delete “30 A, 31, 31 A and 32, 32 A.” and insert -- 30A, 31, 31A and 32, 32A. --, therefor.

In column 31, line 56, delete “ex-. changeable.” and insert -- exchangeable. --, therefor.

In column 32, line 6, after “having” delete “a” and insert -- an --, therefor.

In column 34, line 18, delete “meridonal” and insert -- meridional --, therefor.

In column 35, line 63, delete “meridonal” and insert -- meridional --, therefor.

In column 36, line 47, delete “densitiy” and insert -- density --, therefor.

In column 37, line 52, delete “convave” and insert -- concave --, therefor.

In column 38, line 16, delete “a image” and insert -- an image --, therefor.

In column 38, line 16, delete “22 mm~4.5 mm,” and insert -- 22 mm · 4.5 mm, --, therefor.

In column 39, line 37, delete “Dmax” and insert -- D_{\max} --, therefor.

In column 39, line 58, after “ $COMP1 \cdot N_L$ ” insert -- . --.

In column 40, line 1, delete “Nop” and insert -- N_{op} --, therefor.

In column 40, line 50, delete “ $0.8 \leq |\beta_1| \beta \leq 1.$ ” and insert -- $0.8 \leq |\beta_3| \leq 1.$ --, therefor.

In column 47–48, Table 8A, line 3, delete “34” and insert -- 33 --, therefor.

UNITED STATES PATENT AND TRADEMARK OFFICE
CERTIFICATE OF CORRECTION

PATENT NO. : 7,385,756 B2
APPLICATION NO. : 11/035103
DATED : June 10, 2008
INVENTOR(S) : Shafer et al.

Page 3 of 4

It is certified that error appears in the above-identified patent and that said Letters Patent is hereby corrected as shown below:

In column 49–50, Table 17, line 7, delete “1.438” and insert -- 1.4368 --, therefor.

In column 51–52, Table 17A, line 14, delete “-9157705516-009” and insert -- -915770551e-009 --, therefor.

In column 85–86, Table 36, line 20, delete “1.590831” and insert -- 11.590831 --, therefor.

In column 95, Table 41, line 1, delete “ZNL” and insert -- N_L --, therefor.

In column 98, line 46, in claim 42, delete “(in[mn⁻¹])” and insert -- (in[mm⁻¹]) --, therefor.

In column 98, line 47, in claim 42, delete “(in[mm³¹ 1])” and insert -- (in[mm⁻¹]) --, therefor.

In column 98, line 53, in claim 43, delete “(R²-D²/4)^{0.5}” and insert -- (R²-D²/4)^{0.5} --, therefor.

In column 99, line 50, in claim 57, delete “NA<0.9.” and insert -- NA>0.9. --, therefor.

In column 99, line 60, in claim 59, delete “NA<1.1” and insert -- NA>1.1 --, therefor.

In column 100, line 30, in claim 70, delete “R<300” and insert -- R>300 --, therefor.

In column 107, line 36, in claim 95, delete “projection obiective.” and insert -- projection objective. --, therefor.

In column 108, line 52, in claim 99, delete “minor” and insert -- mirror --, therefor.

In column 108, line 60, in claim 99, after “from” insert -- the --.

UNITED STATES PATENT AND TRADEMARK OFFICE
CERTIFICATE OF CORRECTION

PATENT NO. : 7,385,756 B2
APPLICATION NO. : 11/035103
DATED : June 10, 2008
INVENTOR(S) : Shafer et al.

Page 4 of 4

It is certified that error appears in the above-identified patent and that said Letters Patent is hereby corrected as shown below:

In column 112, line 17, in claim 108, after "from" insert -- the --.

In column 112, line 25, in claim 108, after "near" delete "a".

Signed and Sealed this

Sixteenth Day of December, 2008

A handwritten signature in black ink that reads "Jon W. Dudas". The signature is written in a cursive style with a large initial "J" and "D".

JON W. DUDAS
Director of the United States Patent and Trademark Office

UNITED STATES PATENT AND TRADEMARK OFFICE
CERTIFICATE OF CORRECTION

PATENT NO. : 7,385,756 B2
APPLICATION NO. : 11/035103
DATED : June 10, 2008
INVENTOR(S) : Shafer et al.

Page 1 of 4

It is certified that error appears in the above-identified patent and that said Letters Patent is hereby corrected as shown below:

On page 2, in column 2 Item [56], under "Foreign Patent Documents", line 10, after "1318425 B1" delete "6/2003" and insert -- 3/2006 --, therefor.

On page 2, in column 2 Item [56], under "Foreign Patent Documents", line 12, below "EP 1336 887 8/2003" delete "EP 1336 887 8/2003 A1".

On page 3, in column 1 Item [56], under "Foreign Patent Documents", line 3, below "WO94/06047 3/1994" delete "WO94/06047 A1 3/1994".

On page 3, in column 2 Item [56], under "Other Publications", line 6, delete "No. 13" and insert -- No. 14 --, therefor.

In column 6, line 60, delete "focussing" and insert -- focusing --, therefor.

In column 7, line 10, delete "bundel" and insert -- bundle --, therefor.

In column 7, line 64, delete "magnification" and insert -- magnification --, therefor.

In column 13, line 44, delete "(meridonal)" and insert -- (meridional) --, therefor.

In column 13, line 55, delete " $|p(h)| < P_{\max}$," and insert -- $|p(h)| < P_{\max}$ --, therefor.

In column 14, line 7, delete "ist" and insert -- is --, therefor.

In column 19, line 39, delete "~50 mm." and insert -- 50 mm. --, therefor.

In column 20, line 66, delete "An" and insert -- A --, therefor.

In column 21, line 1, delete "schematric" and insert -- schematic --, therefor.

In column 25, line 31, delete "magnification" and insert -- magnification --, therefor.

In column 26, line 3, delete "arran-ged" and insert -- arranged --, therefor.

In column 27, line 25, delete " $(R-D^2-D^2/4)$ " and insert -- $(R^2-D^2-D^2/4)$ --, therefor.

UNITED STATES PATENT AND TRADEMARK OFFICE
CERTIFICATE OF CORRECTION

PATENT NO. : 7,385,756 B2
APPLICATION NO. : 11/035103
DATED : June 10, 2008
INVENTOR(S) : Shafer et al.

Page 2 of 4

It is certified that error appears in the above-identified patent and that said Letters Patent is hereby corrected as shown below:

In column 27, line 51, delete “catoptic” and insert -- catoptric --, therefor.

In column 31, line 28, delete “1502.” and insert -- 1502, --, therefor.

In column 31, line 31, delete “1602.” and insert -- 1602, --, therefor.

In column 31, line 37, delete “30 A, 31, 31 A and 32, 32 A.” and insert -- 30A, 31, 31A and 32, 32A. --, therefor.

In column 31, line 56, delete “ex-. changeable.” and insert -- exchangeable. --, therefor.

In column 32, line 6, after “having” delete “a” and insert -- an --, therefor.

In column 34, line 18, delete “meridonal” and insert -- meridional --, therefor.

In column 35, line 63, delete “meridonal” and insert -- meridional --, therefor.

In column 36, line 47, delete “densitiy” and insert -- density --, therefor.

In column 37, line 52, delete “convave” and insert -- concave --, therefor.

In column 38, line 16, delete “a image” and insert -- an image --, therefor.

In column 38, line 16, delete “22 mm~4.5 mm,” and insert -- 22 mm · 4.5 mm, --, therefor.

In column 39, line 37, delete “Dmax” and insert -- D_{\max} --, therefor.

In column 39, line 58, after “ $COMP1 \cdot N_L$ ” insert -- . --.

In column 40, line 1, delete “Nop” and insert -- N_{op} --, therefor.

In column 40, line 50, delete “ $0.8 \leq |\beta_1| \leq 1.$ ” and insert -- $0.8 \leq |\beta_1| \leq 1.$ --, therefor.

In column 47–48, Table 8A, line 3, delete “34” and insert -- 33 --, therefor.

UNITED STATES PATENT AND TRADEMARK OFFICE
CERTIFICATE OF CORRECTION

PATENT NO. : 7,385,756 B2
APPLICATION NO. : 11/035103
DATED : June 10, 2008
INVENTOR(S) : Shafer et al.

Page 3 of 4

It is certified that error appears in the above-identified patent and that said Letters Patent is hereby corrected as shown below:

In column 49–50, Table 17, line 7, delete “1.438” and insert -- 1.4368 --, therefor.

In column 51–52, Table 17A, line 14, delete “-9157705516-009” and insert -- -915770551e-009 --, therefor.

In column 85–86, Table 36, line 20, delete “1.590831” and insert -- 11.590831 --, therefor.

In column 95, Table 41, line 1, delete “ ZN_L ” and insert -- N_L --, therefor.

In column 98, line 46, in claim 42, delete “(in[mm⁻¹])” and insert -- (in[mm⁻¹]) --, therefor.

In column 98, line 47, in claim 42, delete “(in[mm³¹])” and insert -- (in[mm⁻¹]) --, therefor.

In column 98, line 53, in claim 43, delete “ $(R^2-D^2/4)^{0.5}$ ” and insert -- $(R^2-D^2/4)^{0.5}$ --, therefor.

In column 99, line 50, in claim 57, delete “ $NA < 0.9$.” and insert -- $NA > 0.9$. --, therefor.

In column 99, line 60, in claim 59, delete “ $NA < 1.1$ ” and insert -- $NA > 1.1$ --, therefor.

In column 100, line 30, in claim 70, delete “ $R < 300$ ” and insert -- $R > 300$ --, therefor.

In column 107, line 36, in claim 95, delete “projection obiective.” and insert -- projection objective. --, therefor.

In column 108, line 52, in claim 99, delete “minor” and insert -- mirror --, therefor.

In column 108, line 60, in claim 99, after “from” insert -- the --.

UNITED STATES PATENT AND TRADEMARK OFFICE
CERTIFICATE OF CORRECTION

PATENT NO. : 7,385,756 B2
APPLICATION NO. : 11/035103
DATED : June 10, 2008
INVENTOR(S) : Shafer et al.

Page 4 of 4

It is certified that error appears in the above-identified patent and that said Letters Patent is hereby corrected as shown below:

In column 112, line 17, in claim 108, after "from" insert -- the --.

In column 112, line 25, in claim 108, after "near" delete "a".

This certificate supersedes the Certificate of Correction issued December 16, 2008.

Signed and Sealed this
Seventeenth Day of February, 2009

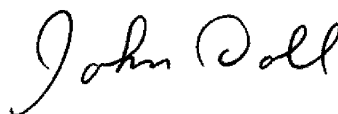

JOHN DOLL
Acting Director of the United States Patent and Trademark Office