



(12) **United States Patent**  
**Brown et al.**

(10) **Patent No.:** **US 6,513,058 B2**  
(45) **Date of Patent:** **Jan. 28, 2003**

(54) **DISTRIBUTION OF MOTION CONTROL COMMANDS OVER A NETWORK**

4,840,602 A 6/1989 Rose

(List continued on next page.)

(75) Inventors: **David W. Brown; Jay S. Clark**, both of Bingen, WA (US)

**FOREIGN PATENT DOCUMENTS**

(73) Assignee: **Roy-G-Biv Corporation**, Bingen, WA (US)

|    |              |         |
|----|--------------|---------|
| EP | 0442676 A2   | 8/1991  |
| EP | 0 281 427 B1 | 8/1992  |
| EP | 0508912 A1   | 10/1992 |
| EP | 0 583 908 A2 | 2/1994  |
| EP | 0245826 A1   | 9/1998  |
| GB | 2 224 896 A  | 12/1991 |
| JP | 59 228473    | 6/1983  |
| WO | WO 92/11731  | 2/1992  |
| WO | WO 93/08654  | 4/1993  |
| WO | WO 95/07504  | 3/1995  |

(\*) Notice: Subject to any disclaimer, the term of this patent is extended or adjusted under 35 U.S.C. 154(b) by 0 days.

(21) Appl. No.: **09/795,777**

(22) Filed: **Feb. 27, 2001**

**OTHER PUBLICATIONS**

(65) **Prior Publication Data**

US 2001/0032268 A1 Oct. 18, 2001

WOSA Backgrounder: Delivering Enterprise Services to the Windows-based Desktop, Jul. 1993, Microsoft Development Library; pp. 1-19.

WOSA INSIDE WINDOWS 95; pp. 348-351.

Software Products for Industrial Automation, ICONICS; 6 pages.

**Related U.S. Application Data**

(List continued on next page.)

(63) Continuation of application No. 09/205,627, filed on Dec. 3, 1998, now Pat. No. 6,209,037, and a continuation-in-part of application No. 09/191,981, filed on Nov. 13, 1998, which is a continuation of application No. 08/656,421, filed on May 30, 1996, now Pat. No. 5,867,385, which is a continuation-in-part of application No. 08/454,736, filed on May 30, 1995, now Pat. No. 5,691,897.

*Primary Examiner*—Krisna Lim

(74) *Attorney, Agent, or Firm*—Michael R. Schacht

(60) Provisional application No. 60/067,466, filed on Dec. 4, 1997.

(57) **ABSTRACT**

(51) **Int. Cl.**<sup>7</sup> ..... **G06F 15/16**

A system for allowing an application program to communicate with any one of a group of supported hardware devices comprising a software system operating on at least one workstation and a network communications protocol. The software system includes a control command generating module for generating control commands based on component functions of an application program, component code associated with the component functions, and the driver code associated with software drivers associated with the hardware devices. The network communication protocol allows the control commands to be communicated from the control command generating module to at least one of the supported hardware devices over the network.

(52) **U.S. Cl.** ..... **709/201; 709/230; 700/1; 700/19; 700/56**

(58) **Field of Search** ..... **709/201, 230; 700/1, 19, 56**

(56) **References Cited**

**U.S. PATENT DOCUMENTS**

|             |         |                |
|-------------|---------|----------------|
| 4,159,417 A | 6/1979  | Rubincam       |
| 4,418,381 A | 11/1983 | Molusis et al. |
| 4,531,182 A | 7/1985  | Hyatt          |
| 4,713,808 A | 12/1987 | Gaskill        |
| 4,767,334 A | 8/1988  | Thorne et al.  |
| 4,809,335 A | 2/1989  | Rumsy          |

**5 Claims, 68 Drawing Sheets**

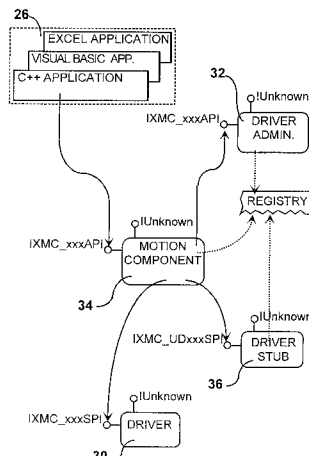

**ABB Inc.**  
**EXHIBIT 1023**

## U.S. PATENT DOCUMENTS

4,846,693 A 7/1989 Baer  
 4,855,725 A 8/1989 Fernandez  
 4,857,030 A 8/1989 Rose  
 4,887,966 A 12/1989 Gellerman  
 4,897,835 A 1/1990 Gaskill  
 4,937,737 A 6/1990 Schwane et al.  
 5,095,445 A 3/1992 Sekiguchi  
 5,120,065 A 6/1992 Driscoll et al.  
 5,126,932 A 6/1992 Wolfson et al.  
 5,168,441 A 12/1992 Onarheim et al.  
 5,175,817 A 12/1992 Adams et al.  
 5,245,703 A 9/1993 Hubert  
 5,247,650 A 9/1993 Judd et al.  
 5,377,258 A 12/1994 Bro  
 5,390,330 A 2/1995 Talati  
 5,392,207 A 2/1995 Wilson et al.  
 5,402,518 A 3/1995 Lowery  
 5,412,757 A 5/1995 Endo  
 5,450,079 A 9/1995 Dunaway  
 5,453,933 A 9/1995 Wright et al.  
 5,465,215 A 11/1995 Strickland et al.  
 5,491,813 A 2/1996 Bondy et al.  
 5,493,281 A 2/1996 Owens  
 5,596,994 A 1/1997 Bro  
 5,600,373 A 2/1997 Chui et al.  
 5,604,843 A 2/1997 Shaw et al.  
 5,607,336 A 3/1997 Lebensfeld et al.  
 5,608,894 A 3/1997 Kawakami et al.  
 5,617,528 A 4/1997 Stechmann et al.  
 5,636,994 A 6/1997 Tong  
 5,652,866 A 7/1997 Aldred et al.  
 5,655,945 A 8/1997 Jani  
 5,666,161 A 9/1997 Kohiyama et al.  
 5,670,992 A 9/1997 Yasuhara et al.  
 5,691,897 A \* 11/1997 Brown et al. .... 318/568.1  
 5,707,289 A 1/1998 Watanabe et al.  
 5,733,131 A 3/1998 Park  
 5,737,523 A 4/1998 Callaghan et al.  
 5,746,602 A 5/1998 Kikinis  
 5,752,880 A 5/1998 Gabai et al.  
 5,764,155 A 6/1998 Kertesz et al.  
 5,790,178 A 8/1998 Shibata et al.  
 5,800,268 A 9/1998 Molnick  
 5,801,946 A 9/1998 Nissen et al.  
 5,818,537 A 10/1998 Enokida et al.  
 5,821,987 A 10/1998 Larson  
 5,822,207 A 10/1998 Hazama et al.  
 5,828,575 A 10/1998 Sakai  
 5,846,132 A 12/1998 Junkin  
 5,852,441 A 12/1998 Nakajima et al.  
 5,855,483 A 1/1999 Collins et al.  
 5,867,385 A \* 2/1999 Brown et al. .... 700/1  
 5,873,765 A 2/1999 Rifkin et al.  
 5,890,963 A 4/1999 Yen  
 5,907,704 A 5/1999 Gudmundson et al.  
 5,907,831 A 5/1999 Lotvin et al.  
 5,914,876 A 6/1999 Hirai  
 5,920,476 A 7/1999 Hennessey et al.  
 5,924,013 A 7/1999 Guido et al.  
 5,960,085 A 9/1999 De La Huerga  
 5,977,951 A 11/1999 Danieli et al.  
 6,078,968 A 6/2000 Lo et al.  
 6,101,425 A \* 8/2000 Govindaraj et al. .... 700/104  
 6,139,177 A 10/2000 Venkatraman et al.  
 6,144,895 A 11/2000 Govindaraj et al.  
 6,216,173 B1 4/2001 Jones et al.

## OTHER PUBLICATIONS

WEB 3.0 Products Brochure, Trihedral Engineering Ltd. (1994); 6 pages.

The Complete, Computer-Based Automation Tool (IGSS) Seven Technologies A/S; 6 pages.  
 Oregon Micro Systems Product Guide; pp. 1–20.  
 AIMAX-WIN Product Brochure, TA Engineering Co., Inc.; 8 pages.  
 XANALOG Model NL-SIM Product Brochure, XANALOG, 4 pages.  
 ExperTune PID Tuning Software, Gerry Engineering Software; 6 pages.  
 PMAC Product Catalog, p. 43.  
 Paragon TNT Product Brochure, Intec Controls corp.; 6 pages.  
 AerotechMotion Control Product Guide; pp. 233–234.  
 OpenBatch Product Brief, PID, Inc.; 6 pages.  
 PC/DSP-Series Motion Controller C Programming Guide; pp. 1–54.  
 FIX Product Brochure, Intellution (1994); 6 pages.  
 Precision Motion Controls Product Guide; p. 17.  
 Compumotor Digiplan (1993–94) Catalog pp. 10–11.  
 Sue Chen, Jonathon Lin; “Computer Numerical Control: Essentials in Programming and Networking”, Part 5, Chapter 27, pp. 824–848.  
 Pritschow et al., “Open System Controllers: Challenge for the Future of the Machine Tool Industry”; pub. Jan. 15, 1993; pp. 449–452.  
 William E. Ford; “What Is an Open Architecture Robot Controller” pub. Aug. 16, 1994; pp. 27–32.  
 Marcos et al., “A New Solution for Integrating Control Devices Involved in Computer-Integrated Manufacturing”; pub. Sep. 02, 1996.  
 Chu and Wang; “Development of a Practical SFC System for CNC Machine Shop”; pub. 1994; pp. 362–367.  
 Microsoft; “The Microsoft Object Technology Strategy” pub. Mar. 1994; pp. 1–33.  
 Microsoft; “Open Systems: Technology, Leadership, and Collaboration”; pub. Mar. 1994; pp. 1–15.  
 Microsoft; Microsoft OLE Today and Tomorrow: Technology Overview; pub. Dec. 1993; pp. 1–9.  
 Microsoft; “Object linking and Embedding 2.0 Background”; pub. Sep. 1993; pp. 1–15.  
 Robert Anderson; “SMART: A Modular Architecture for Robotics and Teleoperation”; pub. 1993; pp. 416–421.  
 Proctor et al., “Validation of Standard Interfaces from a Machine Control”; pub. 1996; pp. 659–664.  
 Altintas et al., “Design and Analysis of a Modular CNC System”; pub. Mar. 4–1990; pp. 305–316.  
 Wright et al.; “Open Architecture Controllers”; pub. Jun. 1997; pp. 60–64.  
 Lutz et al.; “OSACA-The Vendor-Neutral Control Architecture”; pub. Dec. 1997; pp. 247–256.  
 Morales et al.; “A Generalised Software Control System for Industrial Robots”; pub. 1998; pp. 411–416.  
 Feng et al.; “Distributed Control of a Multiple-Tethered Mobile Robot System for Highway Maintenance and Construction”; pub. Nov. 1997; pp. 383–392.  
 Fedowitz; “IRL-Based Expansion of the Commonly Used High-Level Language C for Robot Programming.” pub. Oct. 1995; 5 pages.  
 Szabo et al.; “Validation Results of Specifications for Motion Control Interoperability”; pub. 1997; pp. 166–167.  
 Chang et al.; “Development and Implementation of an Application Programming Interface for PC/DSP-based Motion Control System”; pub. 1998; pp. 94–105.

- Michaloski et al.; "A Framework for Component-base CNC Machines" pub. Nov. 1998; pp. 132-143.
- Bouzouia et al.; "A Three-layer Workcell Control Architecture Design"; pub. May 1998; pp. 1185-1191.
- Muir et al.; "Mechatronic Objects for Real-time Control Software Development"; pub. Nov. 1998; pp. 251-265.
- McGraw et al.; "A Friendly Command, Control, and Information System for Astronomy"; pub. 1996; pp. 356-367.
- Jackman; "Robotic Control Using Sequential Function Charts"; pub. 1996; pp. 120-128.
- Leu et al.; "A Telemufacturing Workcell over the Internet"; pub. Nov. 1998; pp. 230-237.
- "Requirements of Open Modular Architecture Controllers for Applications in the Automotive Industry"; pub. Dec. 13, 1994; pp. 1-13.
- Sperling; "Designing Applications for an OSACA Control"; pub. Nov. 16, 1997; 5 pages.
- Lutz et al.; "OSACA: The Vendor-neutral Control Architecture"; pub. 1997; 10 pages.
- Sperling et al.; "Enabling Open Control Systems: An Introduction to the OSACA System Platform"; pub. May 1996; pp. 1-8.
- Open, Modular Architecture Controls at GM Powertrain; pub. May 14, 1996; pp. 1-33.
- "Technologies Enabling Agile Manufacturing (TEAM) Intelligent Closed Loop Processing"; pub. Jan. 11, 1996; 30 pages.
- "Nemi Low-cost Controller Project" pub. Dec. 1996; total pages 392.
- Protoctor et al.; "Open Architecture Controllers"; pub. Jun. 1997, pp. 60-64.

\* cited by examiner

FIG. 1A

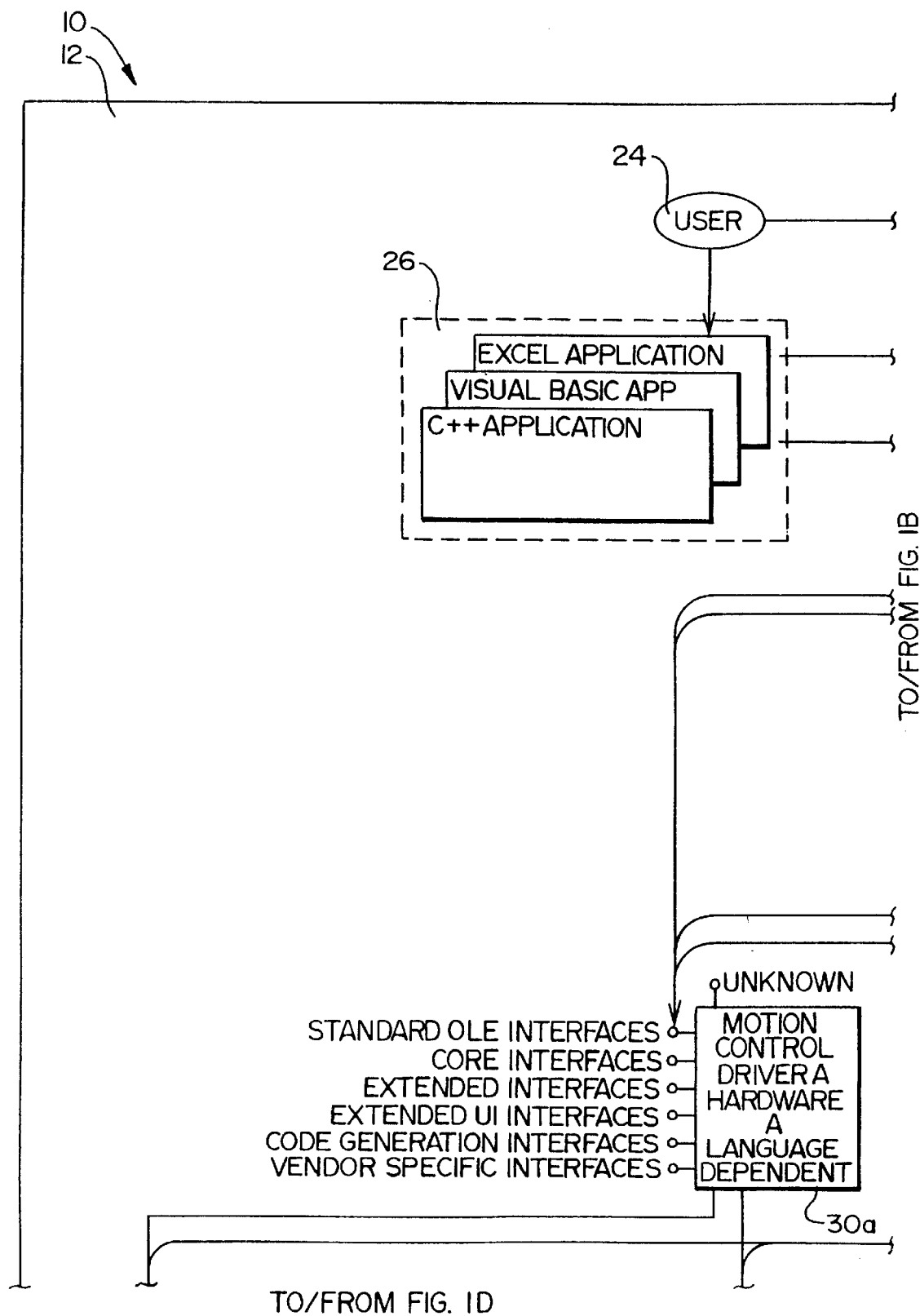
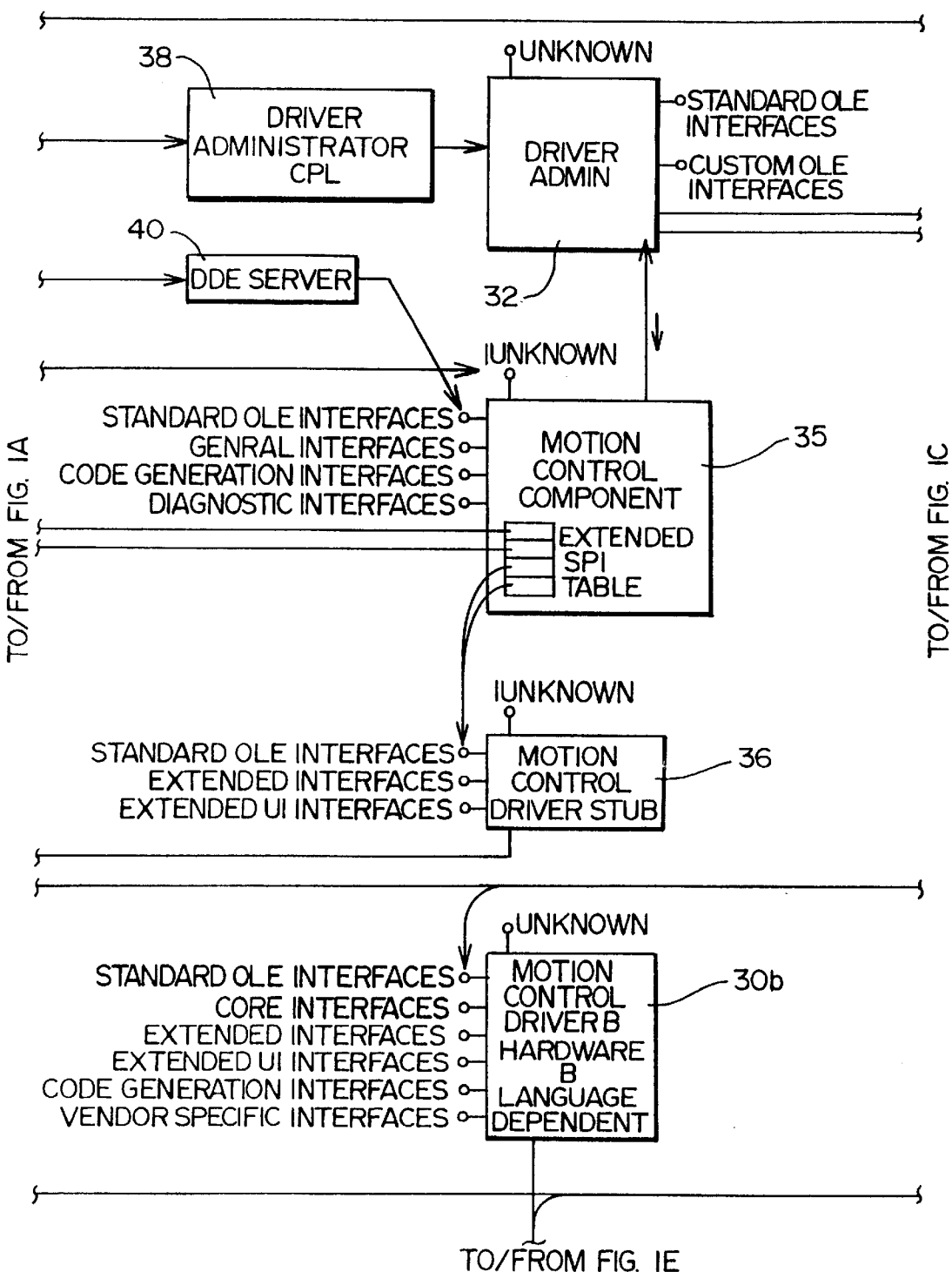

FIG. 1B



# Explore Litigation Insights

Docket Alarm provides insights to develop a more informed litigation strategy and the peace of mind of knowing you're on top of things.

## Real-Time Litigation Alerts



Keep your litigation team up-to-date with **real-time alerts** and advanced team management tools built for the enterprise, all while greatly reducing PACER spend.

Our comprehensive service means we can handle Federal, State, and Administrative courts across the country.

## Advanced Docket Research



With over 230 million records, Docket Alarm's cloud-native docket research platform finds what other services can't. Coverage includes Federal, State, plus PTAB, TTAB, ITC and NLRB decisions, all in one place.

Identify arguments that have been successful in the past with full text, pinpoint searching. Link to case law cited within any court document via Fastcase.

## Analytics At Your Fingertips



Learn what happened the last time a particular judge, opposing counsel or company faced cases similar to yours.

Advanced out-of-the-box PTAB and TTAB analytics are always at your fingertips.

## API

Docket Alarm offers a powerful API (application programming interface) to developers that want to integrate case filings into their apps.

## LAW FIRMS

Build custom dashboards for your attorneys and clients with live data direct from the court.

Automate many repetitive legal tasks like conflict checks, document management, and marketing.

## FINANCIAL INSTITUTIONS

Litigation and bankruptcy checks for companies and debtors.

## E-DISCOVERY AND LEGAL VENDORS

Sync your system to PACER to automate legal marketing.