

Exhibit 2018
Zynga, Inc. v. Personalized Media Communications, LLC
Case IPR2013-00171 (SCM)

- [54] SIGNAL PROCESSING APPARATUS AND METHODS
- [76] Inventors: John C. Harvey, 333 E. 57th St., New York, N.Y. 10022; James W. Cuddihy, 523 E. 14th St., New York, N.Y. 10009
- [21] Appl. No.: 317,510
- [22] Filed: Nov. 3, 1981
- [51] Int. Cl.⁴ H04K 9/00; H04N 7/08
- [52] U.S. Cl. 380/20; 380/9; 380/10; 380/54; 358/142; 358/143
- [58] Field of Search 455/4, 26, 30, 32-34, 455/37, 70; 358/147, 142, 146, 143, 183, 86, 122; 364/521

Attorney, Agent, or Firm—Darby & Darby

[57] ABSTRACT

Apparatus and methods for automatically controlling programming transmissions and presentations on television and radio equipment and monitoring the programming transmitted and presented. ("Programming" here means everything transmitted over television or radio intended for communication of entertainment or to instruct or inform.) The Apparatus can handle programming transmitted either over-the-air (hereinafter, "broadcast") or over hard-wire (hereinafter, "cablecast"). The apparatus receive transmissions from as many as one hundred or more channels that are sequentially scanned by one or more scanners/switches that transfer the transmissions to one or more receiver/decoders that identify signals in the programming and separate the signals from the programming transmissions. The signals may then be transferred through one or more decrypters. The separated and possibly wholly or partially decrypted signals are then transferred through one or more processors and buffers to external equipment and/or data recorders. The data recorders are adapted to output data to remote sites on predetermined instructions. In all these functions, the apparatus are governed by one or more controllers. The methods co-ordinate and instruct equipment in the transmission and presentation of radio and television programming, especially in multi-media and multi-channel presentations, and in certain other functions.

[56] References Cited

U.S. PATENT DOCUMENTS

3,668,307	6/1972	Face et al.	358/114
3,684,823	8/1972	McVoy	455/70
3,833,757	9/1974	Kirk, Jr. et al.	455/4
3,845,391	10/1974	Crosby	455/26
3,891,792	6/1975	Kimura	358/142
3,987,398	10/1976	Fung	455/4
4,138,726	2/1979	Girault et al.	364/521
4,218,698	8/1980	Bart et al.	358/183
4,264,925	4/1981	Freeman et al.	358/143
4,310,854	1/1982	Baer	358/143
4,337,480	1/1982	Bourassin et al.	358/183
4,347,532	8/1982	Korver	358/183
4,381,522	4/1983	Lambert	455/4

Primary Examiner—Salvatore Cangialosi

13 Claims, 22 Drawing Figures

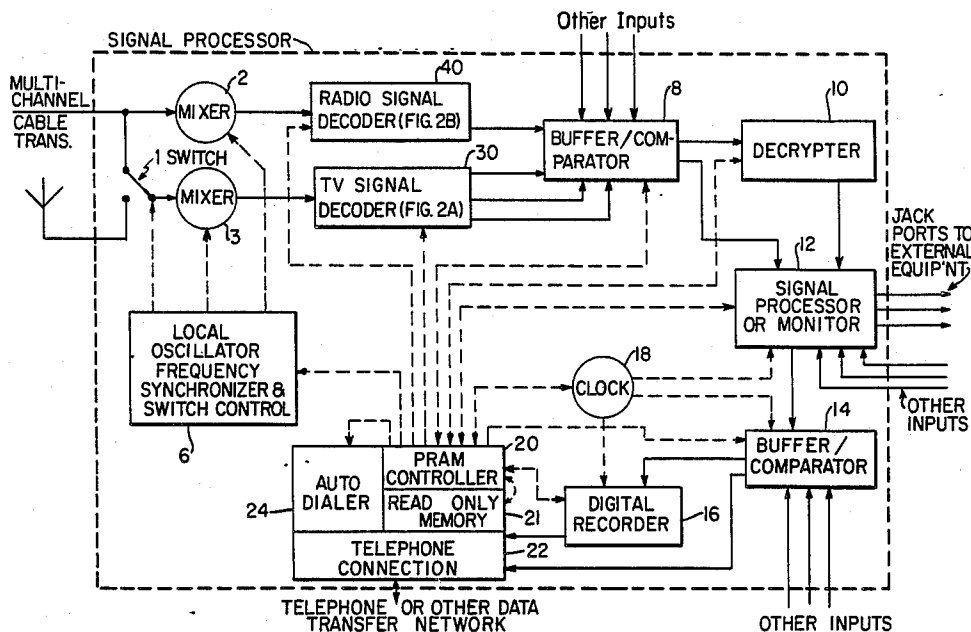

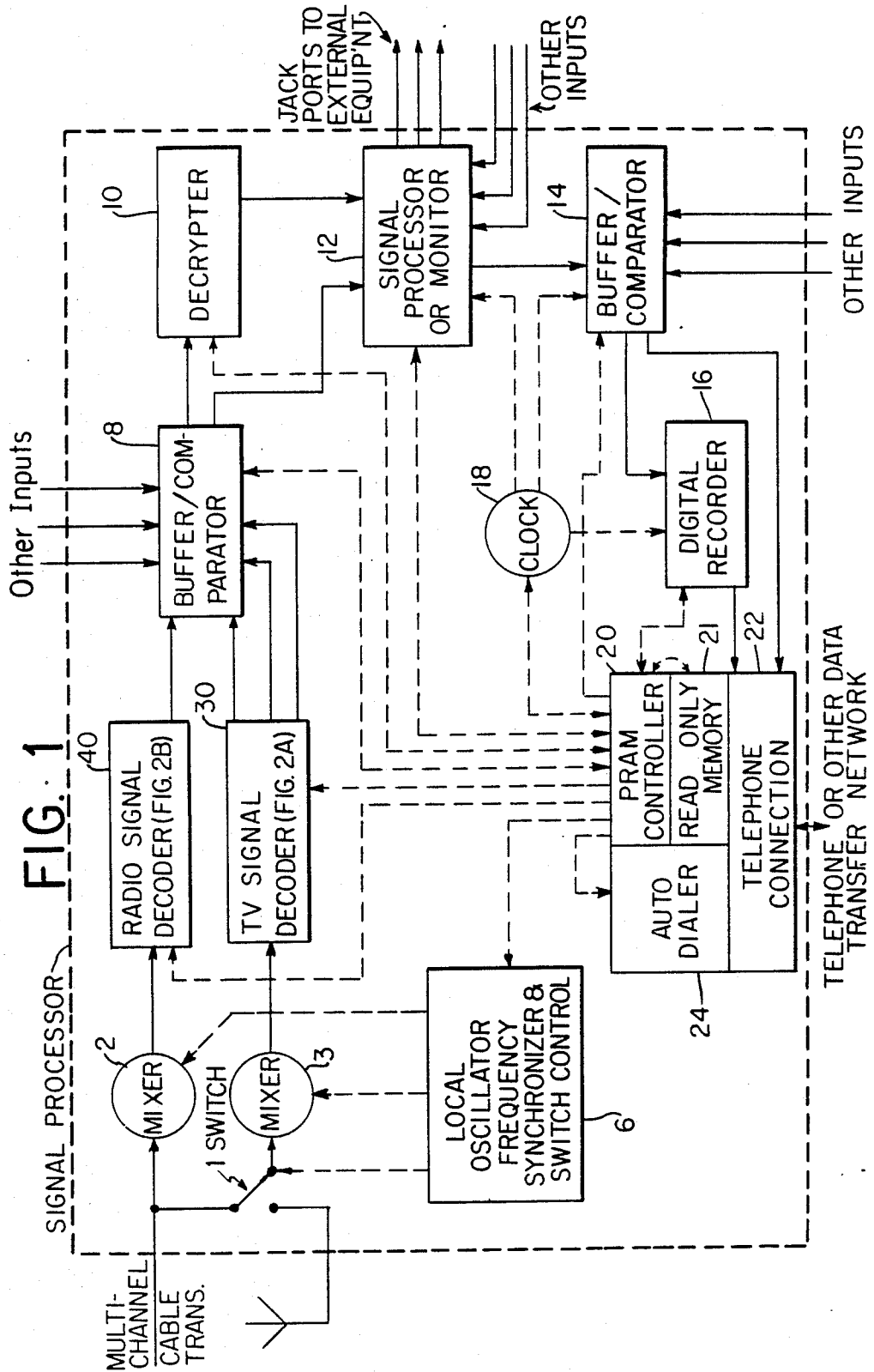
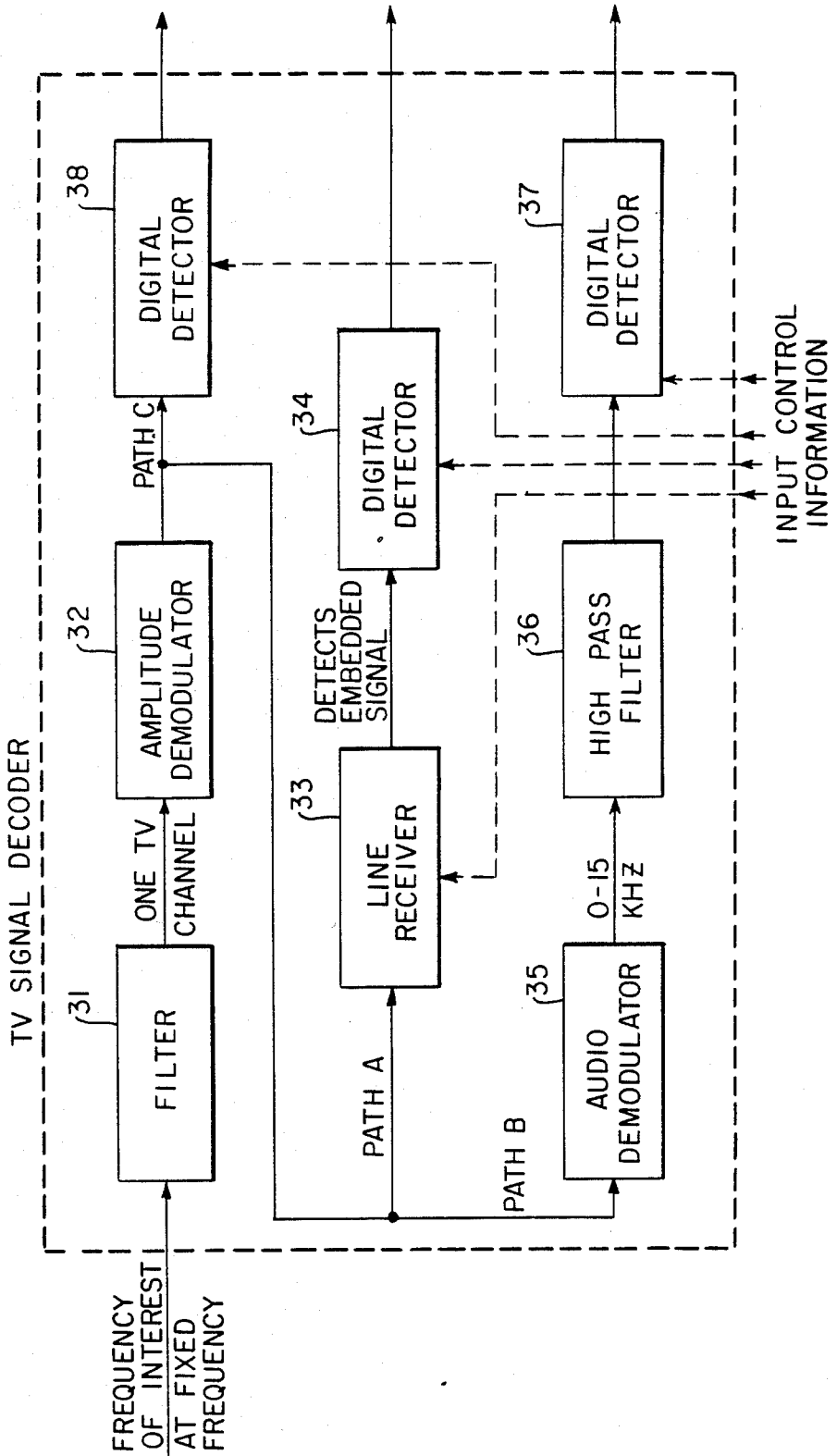
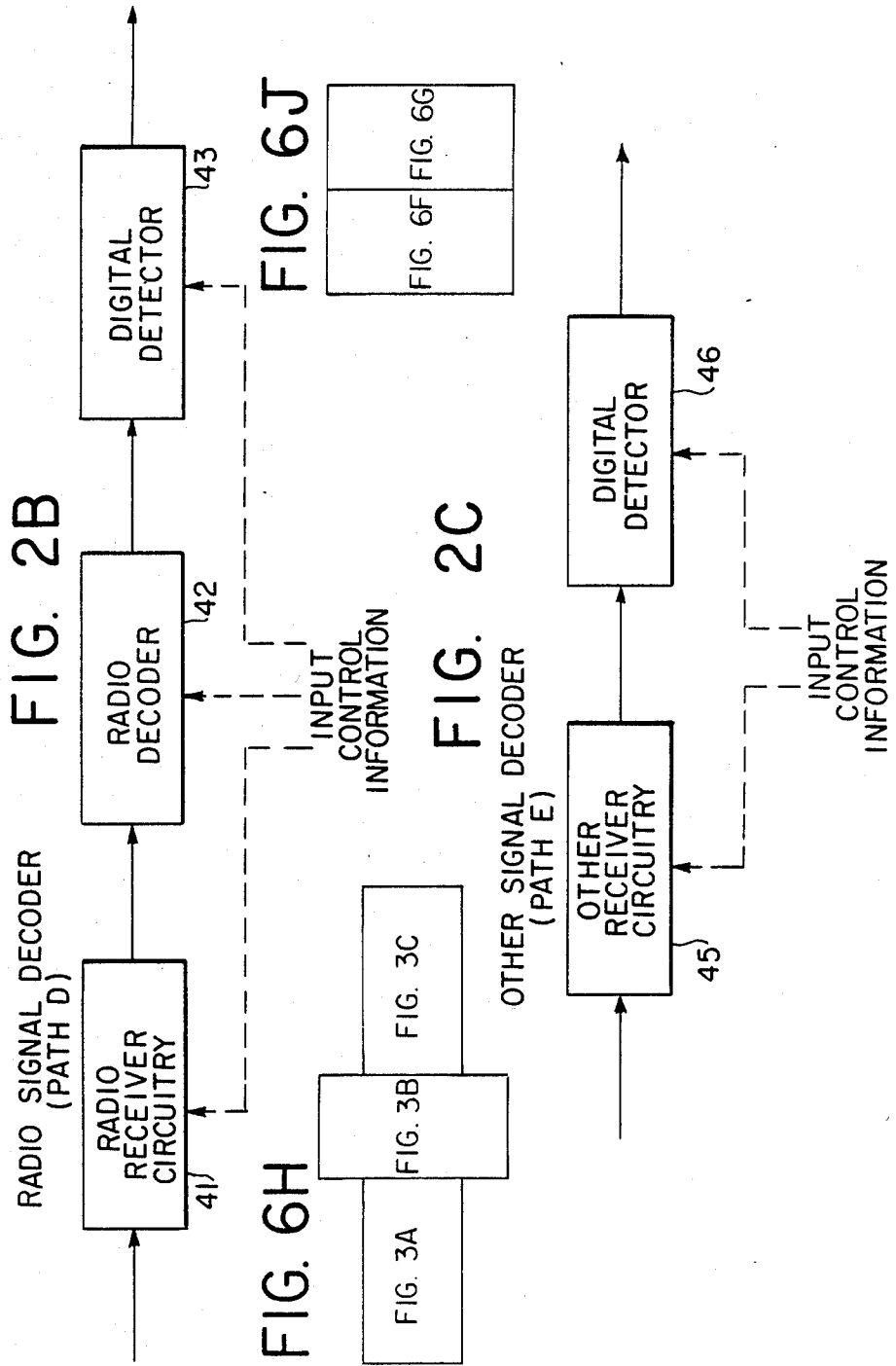

FIG. 2A





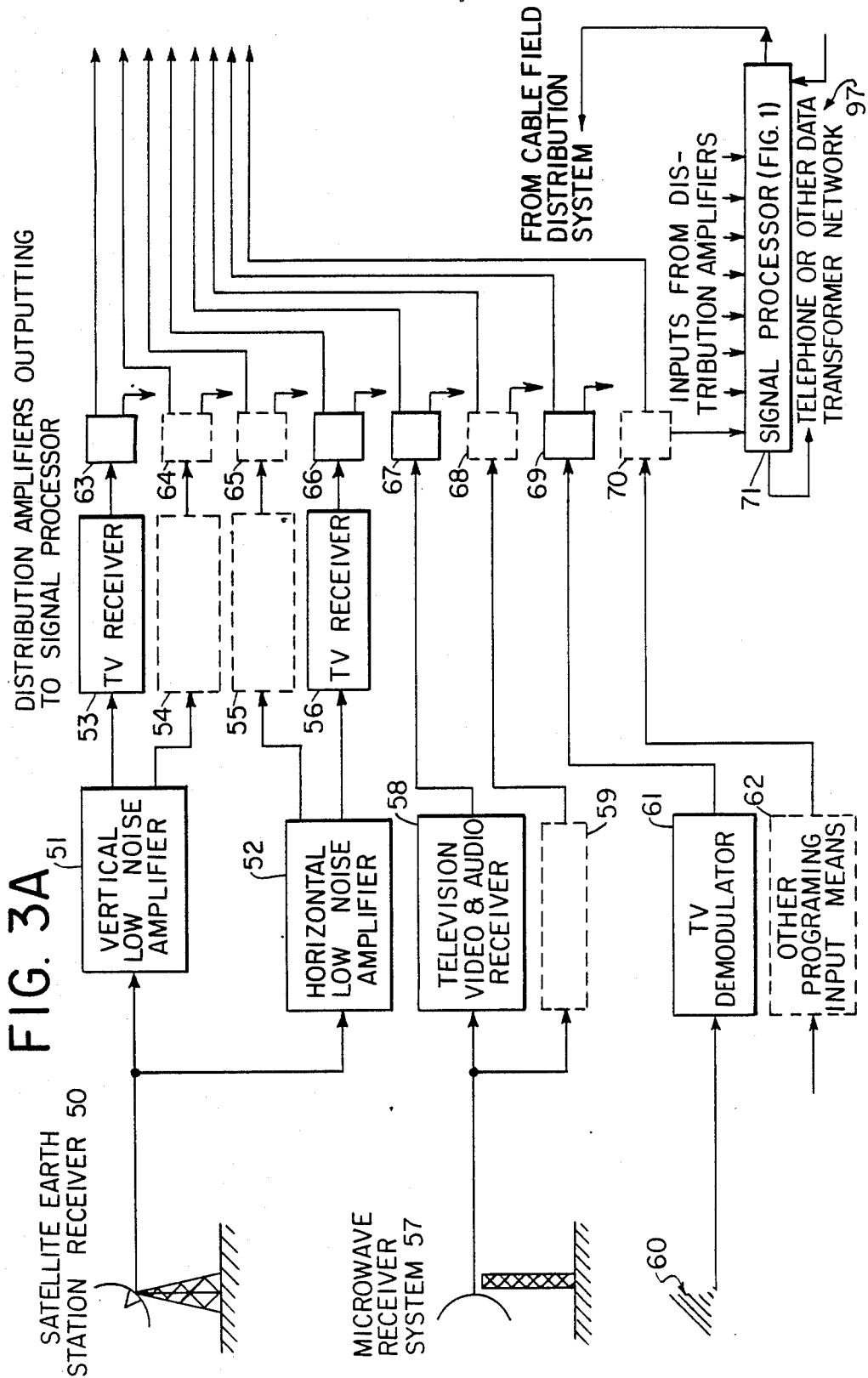

FIG. 3B

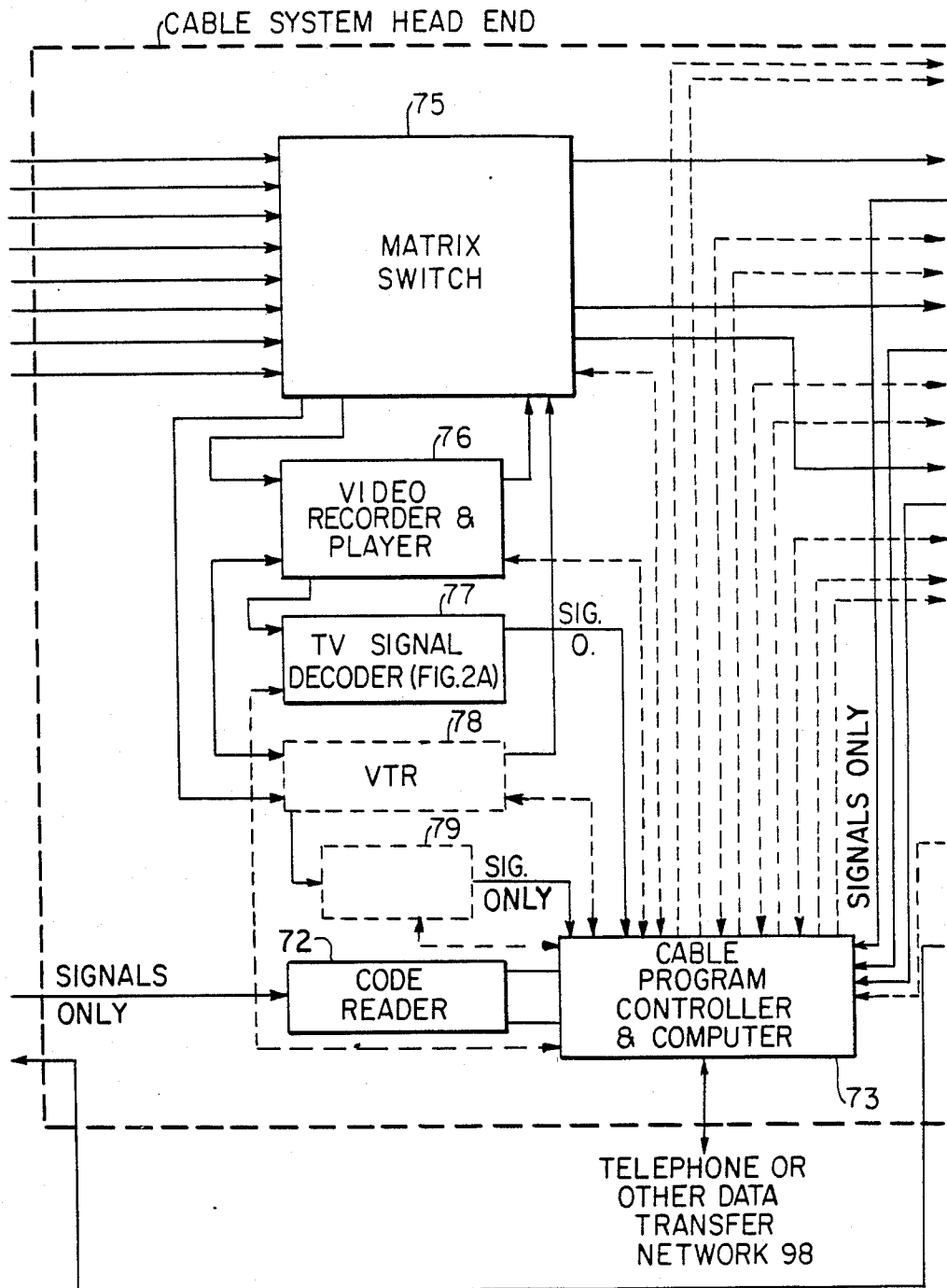

FIG. 3C

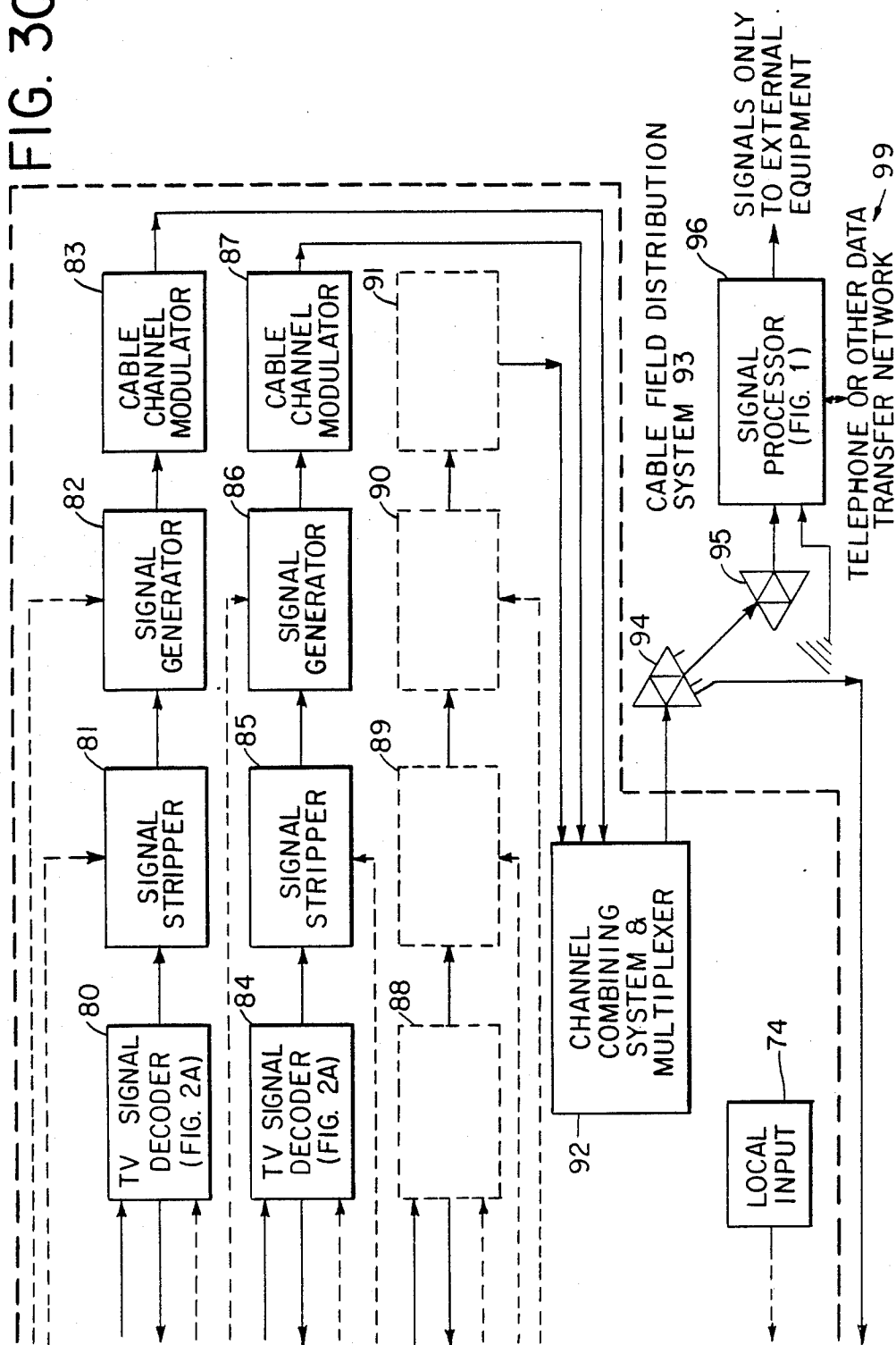

FIG. 4A

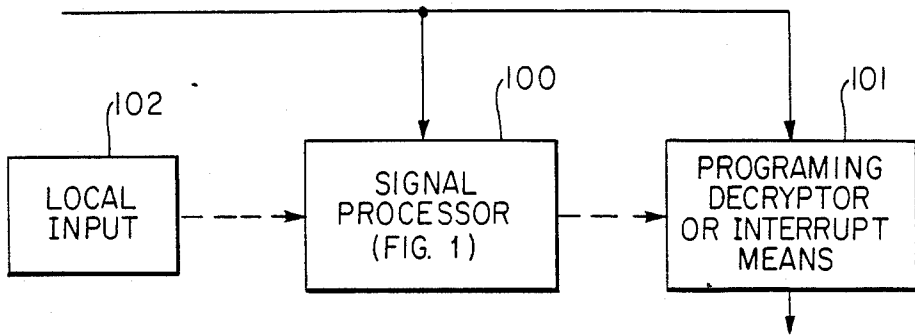

FIG. 4B

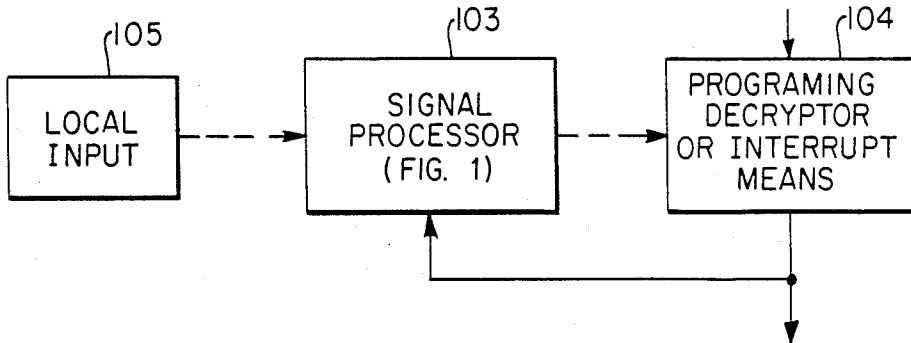

FIG. 4C

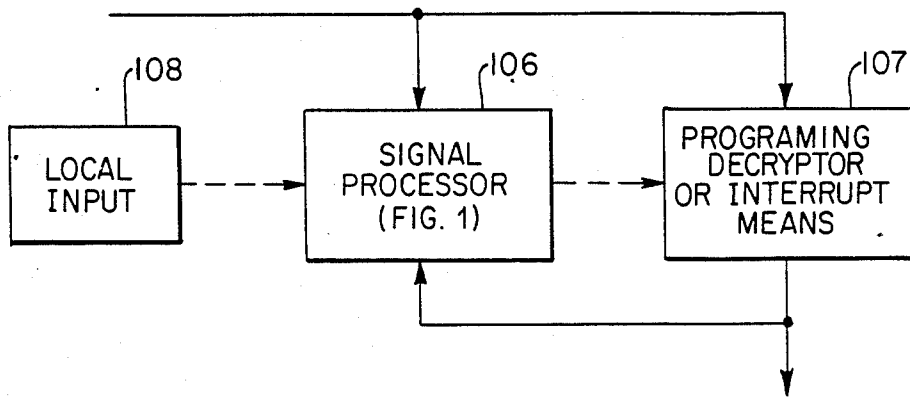

FIG. 4D

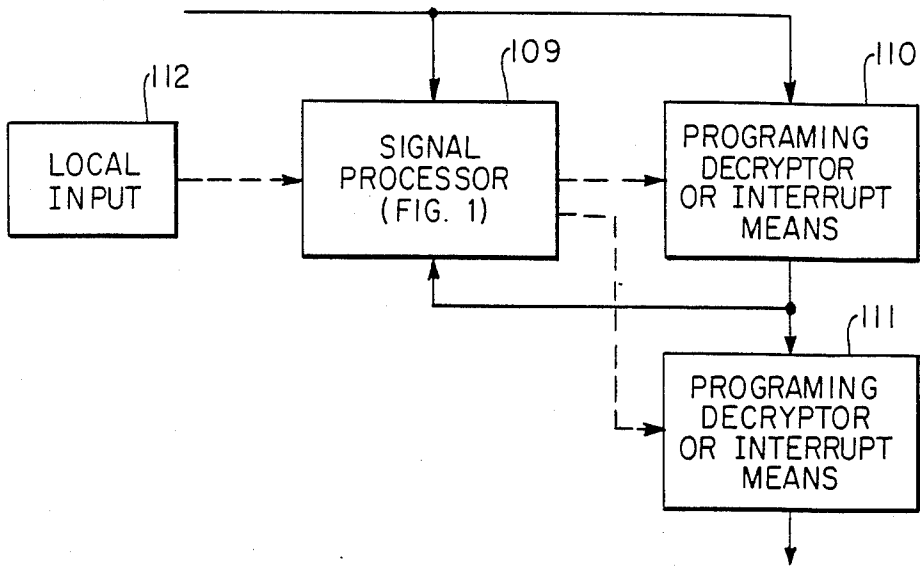
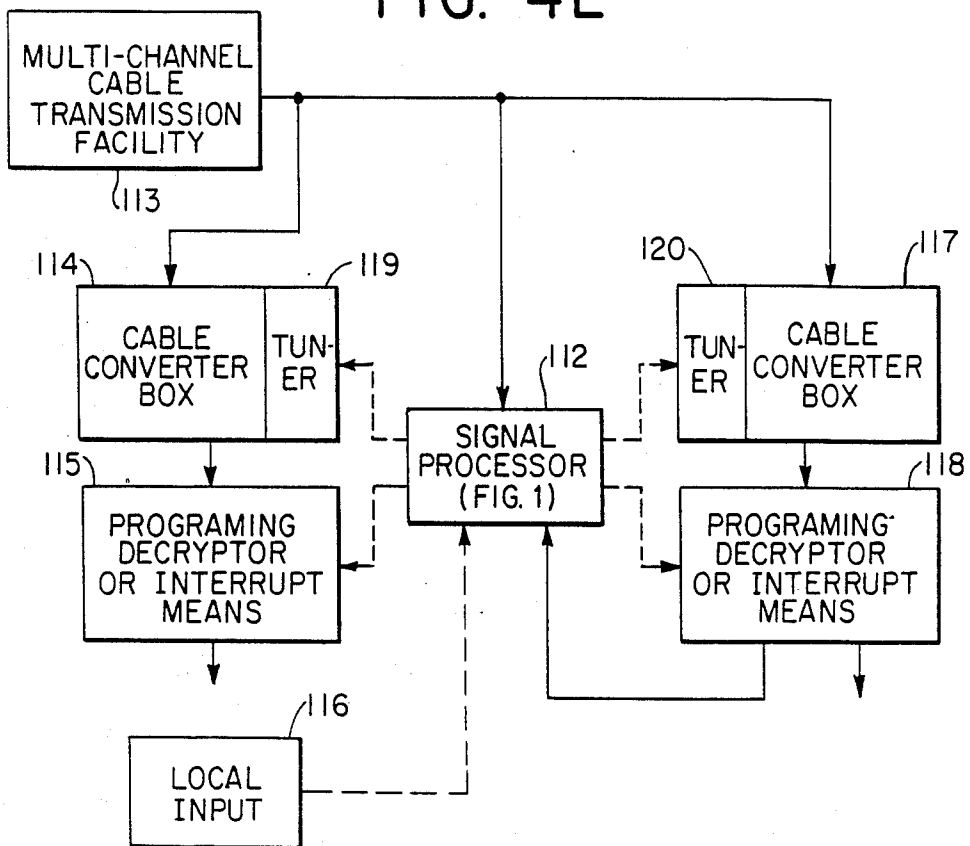
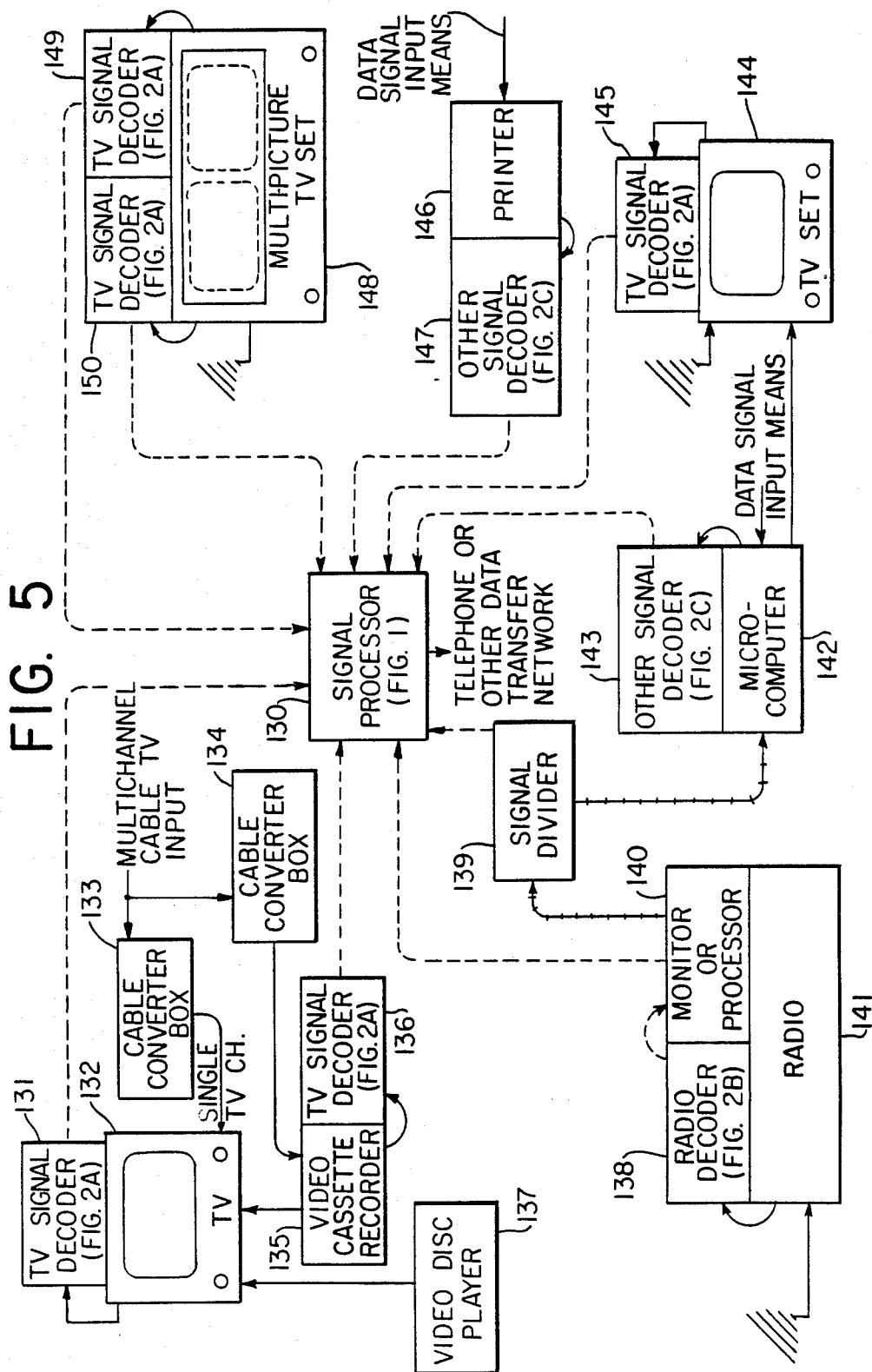

FIG. 4E





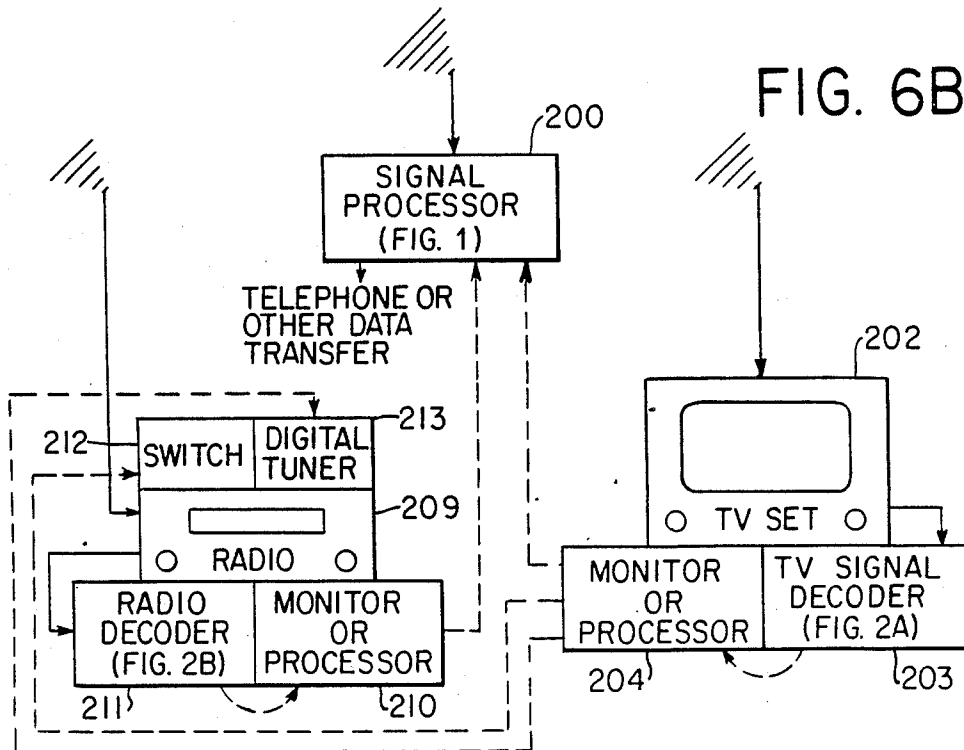
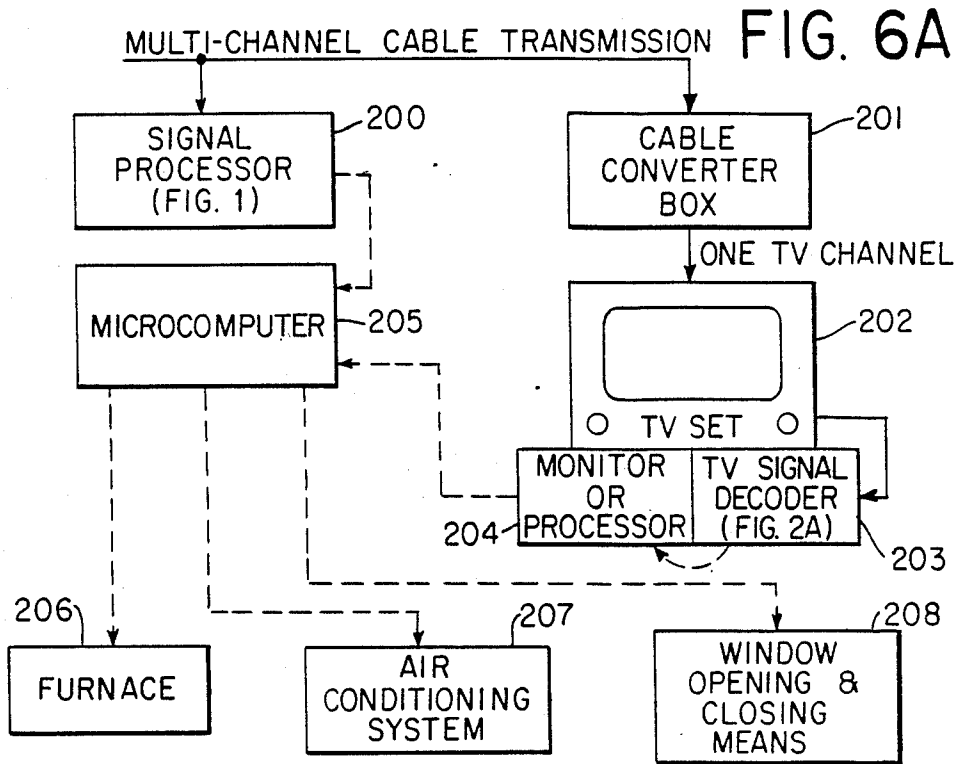

FIG. 6D

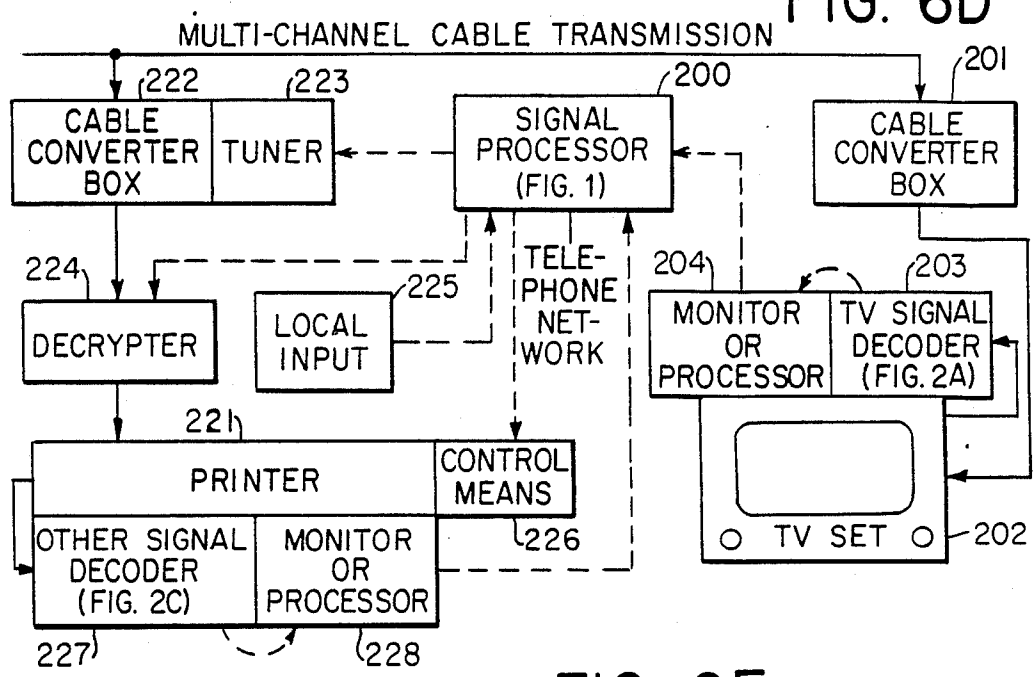

FIG. 6E

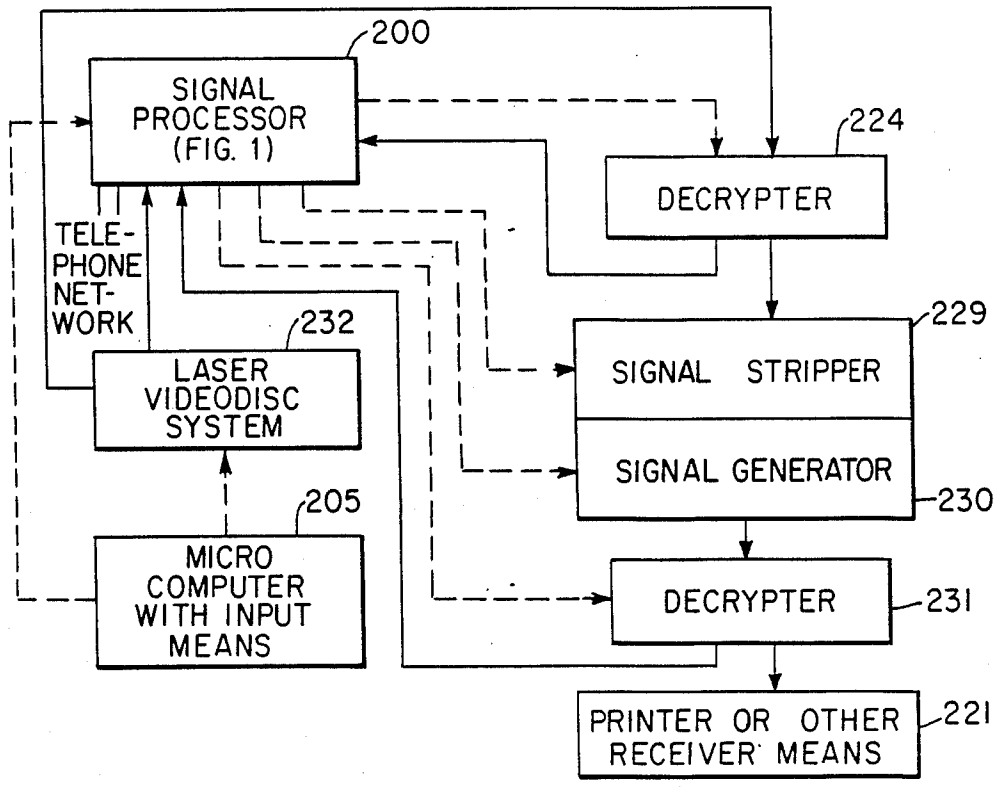

FIG. 6F

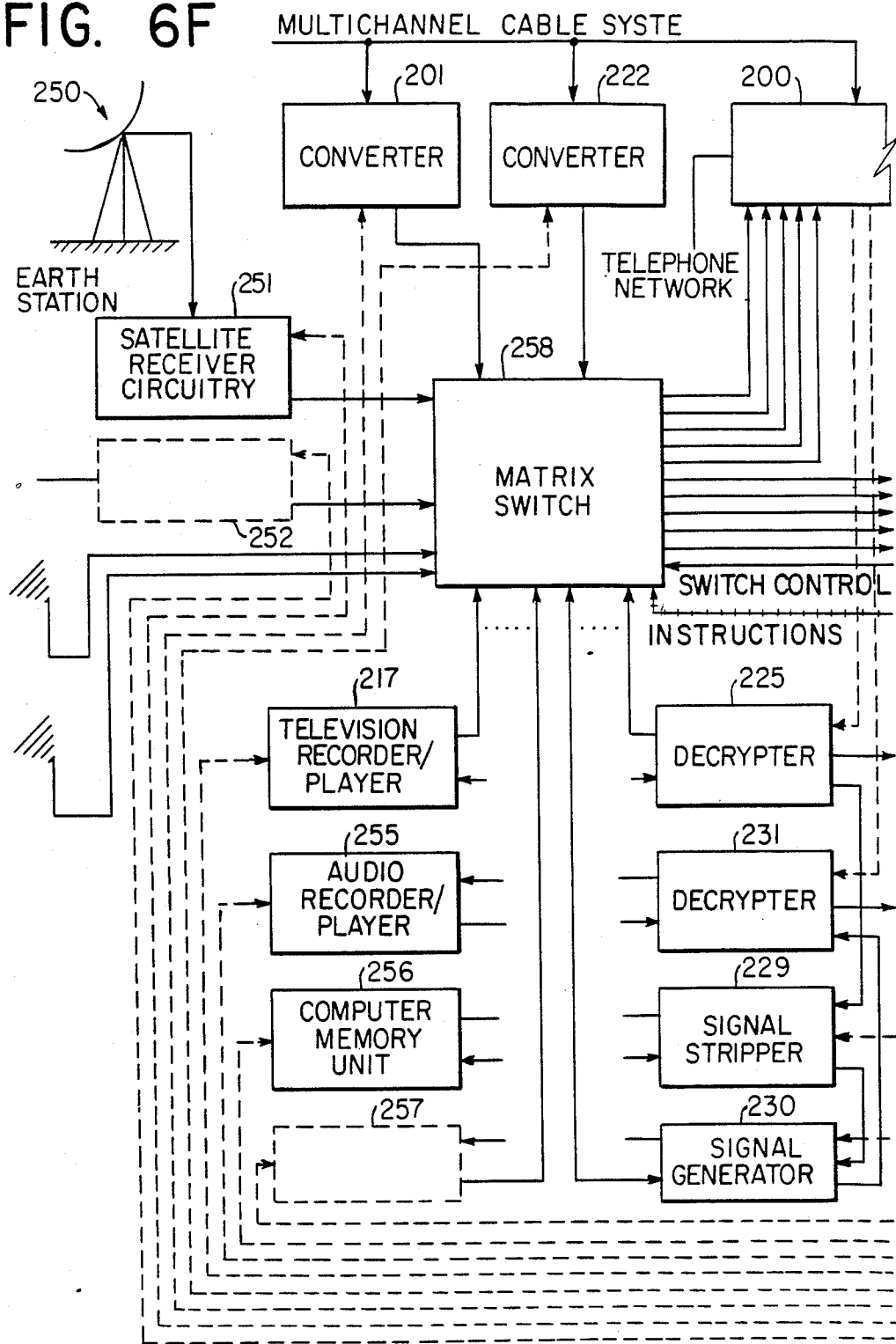
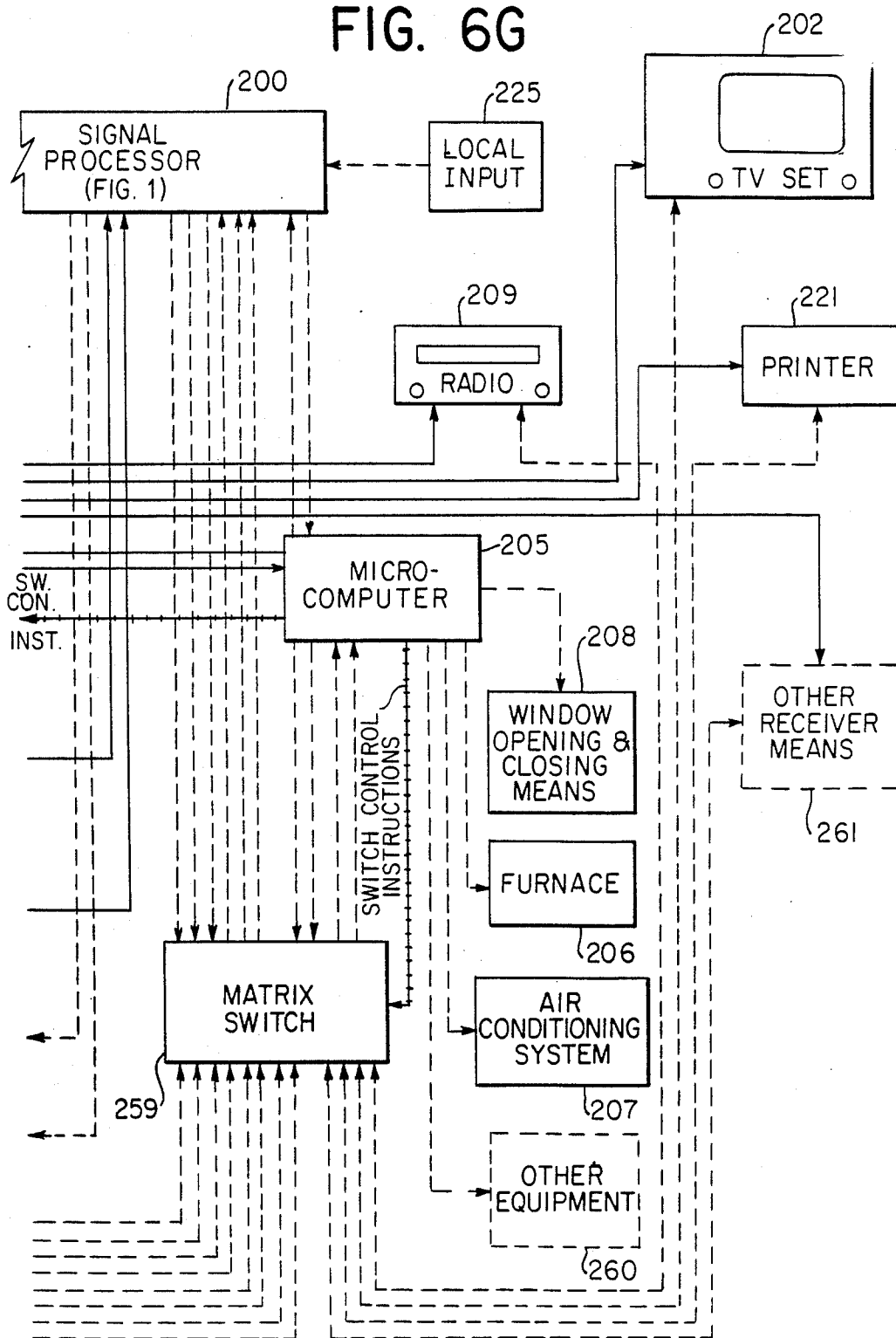

FIG. 6G



SIGNAL PROCESSING APPARATUS AND METHODS

BACKGROUND OF THE INVENTION

At the present time, vast amounts of programing are transmitted through various media throughout the United States which programing is handled with significant degrees of manual processing as different, discrete units of programing transmitted on single channel systems. Broadcasters and cablecasters transmit programing with the expectation that viewers in one place tune to only one channel at a time.

On occasion and on a limited scale, the co-ordination of two media and two channels has occurred. Such co-ordination has taken the form of stereo simulcasts where one local television station broadcasts a program, generally of classical music, and simultaneously, a local radio station broadcasts the same music in stereo. But such simulcasts require significant degrees of manual processing at both the points of origination and reception.

Today great potential exists for a significant increase in the scope and scale of multi-media and multi-channel presentations. This increase is desirable because it will increase variety and add substantially to the richness of presentations as regards both entertainment and the communications of ideas and information.

This potential arises out of two simultaneous, independent trends. One is the development and growth of the so-called cable television industry whose member companies deliver locally not one but many channels of programing. The other is the widespread and growing ownership of computers, especially microcomputers in homes.

It is the object of this invention to unlock this potential by the development of means and methods which permit programing to communicate with equipment that is external to television and radio receivers, particularly computers and computer peripherals such as printers.

It is the further purpose of this invention to provide means and methods to process and monitor such transmissions and presentations at individual receiver sites and to control, in certain ways, the use of transmitted programing and the operation of certain associated equipment. Such receiver sites may be stations or systems that intend to retransmit the programing, or they may be end users of the programing. The present invention contemplates that certain data may be encrypted and that certain data collected from such processing and monitoring will automatically be transferred to a remote geographic location or locations.

In the prior art, there have been attempts to develop systems to control programing and systems to monitor programing, but the two have been treated as separate systems, and each has had limited capacity.

As regards control systems, cueing systems and equipment now exist that transmit instructions to operating equipment at receiver sites by means of tone signals that are carried, in television transmissions, in the audio portion and may be heard by the human ear. Such systems and devices are used to turn on equipment such as videotape players and recorders that have been manually loaded and to tell such equipment how long to run. Such systems operate by transmitting operating signals that precede and follow programing and are called "headers" and "trailers" respectively. The use of

headers and trailers limits prior art in that headers and trailers can become separated from programing, thereby hampering automatic operations. Such prior art techniques have lacked the capacity to process the programing in various ways including to instruct receiver end equipment what specific programing to select to play or record other than that immediately at hand, how to load it on player or recorder equipment, when and how to play it or record it other than immediately, how to modify it, what equipment or channel or channels to transmit it on, when to transmit it, and how and where to file it or refile it or dispose of it. (Within television studios that are original transmitters of programing, certain systems and equipment do exist for certain automatic co-ordination of players, loaders, and other equipment; however, manual instructions still must be given, on site, for the co-ordination of such equipment which instructions are transmitted electronically on hardwire channels that are strictly separate from the channels on which the programing is transmitted and such instructions are never broadcast.) Such prior art systems and equipment have lacked the capacity to automatically coordinate multi-channel and multi-media presentations. They have lacked the capacity to decrypt encrypted processing signals. They have lacked the capacity to monitor whether receiver-end equipment are following instructions properly.

As regards monitoring systems, various systems and devices have been developed to determine what programing is played on television. One such system for monitoring programs is described in U.S. Pat. No. 4,025,851 to Haselwood, et al. Another that monitors by means of audio codes that are only "substantially inaudible" is described in U.S. Pat. No. 3,845,391 to Crosby. Recently devices, called addressable converters, have been developed that facilitate so-called pay-per-view marketing of programing by monitoring what individual television receivers tune to and either permitting or preventing the tuners to tune to given frequencies satisfactorily. Such prior art techniques and equipment have been limited to monitoring single broadcast stations, channels or units and have lacked the ability to monitor multimedia presentations. They have been able to monitor only the audio or the video portion of television transmissions. They have been able either to monitor what is transmitted over one channel or what is received by one or more receivers but not both. They have lacked the capacity to record and transfer information simultaneously. They have been unable to decrypt encrypted signals. They have been able to monitor only single signal word types or word lengths that are placed, within the transmissions, in locations that are unvarying and unvariable. They have lacked the capacity to compare, assemble, and/or evaluate multiword, multi-location signals. Except in the possible case of addressable converters, they have been unable to distinguish the absence of signals or signal words in transmissions. They have lacked the capacity to communicate processing instructions to external equipment as described in the paragraph above. It is the object of the present invention to overcome these and other deficiencies of the prior art.

(The term "signal unit" hereinafter means one complete signal instruction or information message unit. Examples of signal units are a unique code identifying a programing unit, or a unique purchase order number identifying the proper use of a programing unit, or a

general instruction identifying whether a programing unit is to be retransmitted immediately or recorded for delayed transmission. The term "signal word" hereinafter means one full discrete appearance of a signal as embedded at one time in one location on a transmission. Examples of signal words are a string of one or more digital data bits encoded together on a single line of video or sequentially in audio. Such strings may or may not have predetermined data bits to identify the beginnings and ends of words. Signal words may contain partial or whole signal units, whole signal units, or groups of partial or whole signal units or combinations.)

It is a further object of the present invention to process and monitor signals on numerous channels by sequentially scanning each channel in a predetermined manner which manner may be varied. It is also an object of the present invention to prevent unauthorized use of signals and programing by permitting signal encryption, the variation of word numbers, word lengths, word compositions, and/or word locations. It is also an object of this system to process different signal words in different ways. It is also an object of the present invention to provide a record of signals that may be transferred to a geographically distant location on command or predetermined instruction.

Other objects of this invention will appear from the following descriptions and the appended claims.

SUMMARY OF THE INVENTION

The present invention consists of methods and apparatus with several forms.

One method provides a technique whereby a broadcast or cablecast transmission facility can duplicate the operation of a television studio automatically through the use of instruction and information signals embedded in programing either supplied from a remote source or sources or prerecorded. The programing may be delivered to the transmission facility by any means including broadcast, hard-wire, and manual means. The transmission facility may transmit a single channel or multiple channels of programing. The method includes a monitoring technique to construct a record for each transmitted channel that duplicates the log that the Federal Communications Commission requires broadcast station operators to maintain. The method permits the transfer of such records to a predetermined site or sites in a predetermined fashion or fashions.

Another method has application at receiver sites such as private homes or public places like theaters, hotels, brokerage offices, etc., whether commercial establishments or not. This method provides techniques whereby, automatically, single channel, single medium presentations, be they television, radio, or other electronic transmissions, may be recorded, co-ordinated in time with other programing previously transmitted and recorded, or processed in other fashions. Multimedia presentations may be co-ordinated in time and/or in place as, for example, when real-time video programing is co-ordinated with presentations from a microcomputer working with data supplied earlier. This method provides techniques whereby the timing and fashion of the playing, processing, and co-ordination of a presentation or presentations may be determined at the time and place of transmission or of presentation, either in whole or in part, either locally or remotely, or a combination of these factors. The method provides monitoring techniques to develop data on patterns of viewership and to permit the determination of specific usage at individual

receiving sites for various purposes including, for example, the billing of individual customers. The method provides techniques whereby unauthorized use of programing and/or of signals may be prevented.

These techniques employ signals embedded in programs. The advantage of such embedded signals, as compared to header and trailer signals, is that they cannot become separated inadvertently from the programing and, thereby, inhibit automatic processing, that they can convey signals to equipment that must switch manners or modes of operation during transmissions of individual units of programing, and that they can be monitored. (The techniques described here may use headers and trailers from time to time.) The embedded signals may run and repeat continuously throughout the programing or they may run only occasionally or only once. They may appear in various and varying locations. In television they may appear on one line in the video portion of the transmission, or on a portion of one line, or on more than one line, and will probably lie outside the range of the television picture displayed on a normally tuned television set. In television and radio they may appear in a portion of the audio range that is not normally rendered in a form audible to the human ear. In television audio, they are likely to lie between eight and fifteen kilohertz. Signals may also be transmitted on frequencies outside the ranges of television and radio. Different and differing numbers of signals may be sent in different and differing word lengths and locations.

The present invention provides a method for obscuring the meaning of the signals to prevent unauthorized use of the signals and of their associated programing. Their meanings may be obscured through encryption so that apparatus described below are necessary to decrypt them. In addition, the pattern of the composition, timing, and location of the signals may vary in such ways that only receiving apparatus that are preinformed regarding the patterns that obtain at any given time will be able to process the signals correctly. Both the arrangement of signal units in signal words and the locations, timings, and lengths of signal words in individual transmissions or groups of transmissions may vary in fashions that can only be interpreted accurately by apparatus that are preprogramed with the keys to such variations.

The present invention also provides a method for identifying attempts to make unauthorized use of signals and the programing associated with signals. When an apparatus finds that signal words fail to appear in places and at times when and where they are expected, the apparatus may automatically contact one or more remote sites and may or may not disable the flow of programing in one or more ways.

The present invention contemplates signal processing apparatus comprising a device or devices that can selectively scan transmission channels as directed. The channels may convey television, radio, or other transmission frequencies. The input transmissions may be received by means of antennas or from hard-wire connections. The scanners/switches, working in parallel or series or combinations, transfer the transmissions to receiver/-decoder/detectors that identify signals encoded in programing transmissions and convert the encoded signals to digital information; decryptors that may convert the received information, in part or in whole, to other digital information according to preset methods or patterns; and one or more processor/monitors and/or buffer/-

comparators that organize and transfer the information stream. The processors and buffers can have inputs from each of the receiver/detector lines and evaluate information continuously. From the processors and buffers, the signals may be transferred to external equipment such as computers, videotape recorders and players, etc. And/or they may be transferred to one or more internal digital recorders that receive and store in memory the recorded information and have connections to one or more remote sites for further transmission of the recorded information. The apparatus has means for external communication and an automatic dialer and can contact remote sites and transfer stored information as required in a predetermined fashion or fashions. The apparatus has a clock for determining and recording time as required. It has a read only memory for recording permanent operating instructions and other information and a programmable random access memory controller ("PRAM controller") that permits revision of operating patterns and instructions. The PRAM controller may be connected to all internal operating units for full flexibility of operations.

Signal processing apparatus that are employed in specific situations that require fewer functions than those provided by the basic apparatus described above may omit one or more of the specific operating elements described above.

BRIEF DESCRIPTION OF THE DRAWINGS

FIG. 1 is a block diagram of one embodiment of signal processing apparatus.

FIG. 2A is a block diagram of a TV signal decoder apparatus.

FIG. 2B is a block diagram of a radio signal decoder apparatus.

FIG. 2C is a block diagram of another signal decoder apparatus.

FIGS. 3A 3B and 3C are a block diagram of signal processing apparatus and methods as they might be used in an intermediate transmission facility, in this case a cable system head end.

FIG. 4A is a block diagram of a signal processor and a programing decryptor or other interrupt means with signals input to the signal processor before programing decryption. Also included is a local input.

FIG. 4B is a block diagram of a signal processor and a decryptor/interruptor with signals input to the signal processor in programing after programing decryption.

FIG. 4C is a block diagram of a signal processor and a decryptor/interruptor with signals input both before and after programing decryption.

FIG. 4D is a block diagram of a signal processor and a multiple decrypter/interrupters in series, with signals input both before and after programing decryption.

FIG. 4E is a block diagram of a signal processor and multiple decryptor/interrupters and with signals from one channel needed for decryption of a second channel.

FIG. 5 is a block diagram of signal processor apparatus monitoring various programing and viewership patterns.

FIG. 6A is a block diagram of signal processor apparatus and methods used to instruct and inform external equipment governing the environment of the local receiver site.

FIG. 6B is a block diagram of signal processor apparatus and methods used to co-ordinate a multi-media, multi-channel presentation and monitor such viewership.

FIG. 6C is a block diagram of signal processor apparatus and methods used to organize the reception of selected information and programing and to co-ordinate multi-media, multi-channel presentations in time.

FIG. 6D is a block diagram of another example of multi-media, multi-channel co-ordination. In this case, the co-ordination of video and print.

FIG. 6E is a block diagram of signal processing techniques co-ordinated with programing decryption techniques to facilitate electronic distribution of copyrighted materials while discouraging pirating and unauthorized copying.

FIGS. 6F and 6G comprise a block diagram of signal processor apparatus and methods as they might be used at a consumer receiver site.

FIG. 6H shows the relationship of FIGS. 3A, 3B, and 3C.

FIG. 6J shows the relationship of FIGS. 6F and 6G.

DESCRIPTION OF THE PREFERRED EMBODIMENTS

The Signal Processor Apparatus

A signal processor apparatus for simultaneous use with a cablecast input that conveys both television and radio programing and a broadcast television input is shown in FIG. 1. As shown, the input signals are the entire range of frequencies or channels transmitted on the cable and the entire range of broadcast television transmissions available to a local television antenna of conventional design. The cable transmission is input simultaneously to switch 1 and mixer 2. The broadcast transmission is input to switch 1. Switch 1 and mixers 2 and 3 are all controlled by local oscillator and switch control 6. The oscillator, 6, is controlled to provide a number of discrete specified frequencies for the particular radio and television channels required. The switch, 1, acts to select the broadcast input or the cablecast input and passes transmissions to mixer 3 which, with the controlled oscillator, 6, acts to select a television frequency of interest that is passed at a fixed frequency to a TV signal decoder, 30.

Decoder 30 is shown more fully in FIG. 2A. In the decoder, 30, the frequency passes first through filter 31 which defines the particular channel of interest to be analyzed. The television channel signal is then transmitted to a standard amplitude demodulator, 32, which uses standard demodulator techniques well known in the art to define the television base band signal. This base band signal is then transmitted through separate paths to three separate detector devices. These separate detectors are designed to act on the particular frequency ranges in which the encoded information may be found. The first path, designated A, inputs to a standard line receiver, 33, well known in the art. This line receiver, 33, detects the existence of an embedded signal or signals in one or more of the lines normally used to define a television picture. It receives and detects only that portion or portions of the overall video transmission and passes this line portion or portions to a digital detector, 34, which acts to decode the encoded signal information in the line portion or portions. The base band signal is also inputted through path B to an audio demodulator, 35, which further inputs a high pass filter, 36, and a digital detector, 37. The digital detector, 37, through standard detection techniques well known in the art, determines whether a particular signal is present in the transmission in a predetermined fashion. Path C inputs the separately defined transmission to a digital

detector, 38. Detectors, 34, 37, and 38, line receiver, 33, and high pass filter, 36, all operate in predetermined fashions which fashions may be changed by external controller, 20 (referring to FIG. 1), to be described below.

If one returns to FIG. 1, one sees that the three separate lines of information outputted from TV signal decoder, 30, are then gated to a buffer/comparator, 8, which also receives other inputs from the other separate receivers comprising similar filters, demodulators, and decoders for other channels of interest.

One such other path is that from mixer 2. Mixer 2 and the controlled oscillator, 6, act to select a radio frequency of interest which is inputted to a radio signal decoder, 40, shown in FIG. 2B. The frequency passes first through standard radio receiver circuitry, 41, well known in the art, a radio decoder, 42, and a standard digital detector, 43. All operate in predetermined fashions that may be changed by external controller, 20 (referring to FIG. 1). As FIG. 1 shows, the radio signal detector outputs to buffer/comparator 8.

(The signal processor apparatus described here is configured to receive broadcast TV transmissions and cablecast TV and radio transmissions. Were it desirable to process signals in other transmissions such as broadcast microwave transmissions or cablecast transmissions on other than standard TV and radio frequencies, the mixers and switches would be appropriately reconfigured and one or more other signal decoders as described in FIG. 2C would be added. As FIG. 2C shows, the desired frequencies would pass through appropriate other receiver circuitry, 45, well known in the art, and an appropriate digital detector, 46, before being outputted to buffer/comparator 8. These, too, can be controlled by controller, 20 (referring to FIG. 1).)

Buffer/comparator, 8, organizes the data stream that it receives according to a pre-determined fashion that enables buffer/comparator, 8, among other things, to assemble signal units from signal words. In a pre-determined fashion, buffer/comparator, 8, identifies signal words and/or signal units that must be decrypted, either in whole or in part, and passes identified signal words and/or units to decrypter, 10. Decrypter, 10, uses conventional decrypter techniques, well known in the art, in a pre-determined fashion to decrypt such signals as required. Decrypter, 10, then passes the decrypted signals to processor or monitor, 12. Buffer/comparator, 8, passes signal words and units not identified as requiring decryption directly to processor or monitor, 12.

Processor or monitor, 12, analyzes, in a pre determined fashion, the signal words and units that it receives and determines whether they are to be passed to external equipment or to buffer/comparator, 14, for further processing or both. If a signal or signals are to be passed externally, processor unit, 12, identifies, in a pre-determined fashion, the external equipment to which the signal or signals are addressed and passes them to appropriate jack ports for external transmission. If they are to be processed further, processor or monitor, 12, passes them to buffer/comparator, 14. Processor or monitor, 12, communicates with clock, 18, and has means to delay the transfer of signals, in a predetermined fashion, when delayed transfer is determined, in a predetermined fashion, to be required.

Buffer/comparator, 14, has means for identifying, according to a predetermined fashion, which signals are to be recorded. To avoid overloading digital recorder, 16, with duplicate data, buffer/comparator, 14, has

means for counting and discarding duplicate signals. Buffer/comparator, 14, is connected to clock, 18, and has means for adding information such as time of receipt, for example, to signals. Upon determining in a pre-determined fashion that a signal word or unit should be passed, buffer/comparator, 14, transmits the combined information to a digital recorder, 16. Buffer/comparator, 14, also has means for determining, in a predetermined fashion, when signals require transfer immediately to a remote site and for communicating such a requirement to controller, 20, and such signals directly with the remote site via telephone connection, 22.

Digital recorder, 16, may be a memory storage element of standard design. It has means for determining in a predetermined fashion how full it is and passing this information to controller, 20. The pre determined fashion may include provisions whereby recorder, 16, informs controller, 20, automatically when it reaches a certain level of fullness.

The signal processor apparatus also has a controller device which includes programable random access memory controller 20, read only memory 21 that may contain a unique digital code capable of identifying the signal processing apparatus uniquely, an automatic dialing device 24, and a telephone unit, 22. The controller, 20, governs the operation of all operating elements of the apparatus. The controller, 20, inputs the local oscillator, 6, a sequential pattern to select the various channels to be received by switch, 1, and mixers, 2 and 3. This then allows the channels to be diverted to the detectors, receivers, and decoders in any predetermined pattern desired. The controller, 20, can instruct signal decoders, 30 and 40, when, where, and how to look for signal words, which allows signal words to be received in any pattern or patterns. It can instruct buffer/comparator, 8, how to assemble signal words into signal units and join units together for further transfer and how to determine which signals to pass to decrypter, 10. It can tell decrypter, 10, when and how to change decryption patterns, fashions, and techniques. It can tell processor or monitor, 12, how to determine which signals to pass externally and when and where and how to determine which signals to pass to buffer/comparator, 14. It can tell buffer/comparator, 14, what and how to count, what and how to mark signals, and what-received signals to discard. The controller, 20, also inputs the digital recorder, 16, to direct it to output the information from the memory of the recorder, 16, to telephone connection, 22, and thence to the collection site at the remote geographical location. The controller, 20, also controls the automatic telephone dialing device, 24, to allow the apparatus to automatically output its own information in accordance with a predetermined sequence and to change telephone numbers dialed as required.

To facilitate the operation of the device, the controller, 20, can receive information from all operating elements of the apparatus. Control signals can be passed to the apparatus by means of the programming transmissions input at switch, 1, and mixer, 2. An example of such a control signal is an instruction for the apparatus to contact a remote telephone unit. The processor unit, 12, has the capacity to identify instruction signals for controller, 20, and pass them to controller, 20, over control information lines. Buffer/comparator, 14, has the capacity to pass received time signals to the controller, 20, in a predetermined fashion set by and changeable by controller, 20. Buffer/comparator, 8, and monitor or pro-

cessor, 12, each have the capacity to inform controller, 20, when signals that they are instructed to look for in predetermined fashions, set by and changeable by controller, 20, fail to appear. Oscillator, 6, the controller, 20, and buffer/comparator, 8, can interact in such a fashion that buffer, 8, can identify the channel that any given signal is received on and mark the signal for subsequent identification of the channel. Digital recorder, 16, can tell the controller, 20, when it reaches predetermined levels of fullness to permit the controller, 20, to instruct auto dialer, 24; to contact an appropriate remote site allowing the recorder, 16, to output its data making memory available. In normal operation, controller, 20, may be instructed by the remote site to erase recorder, 16, which instruction controller, 20, effects through communication with recorder, 16; however, controller may ignore such an instruction in a predetermined fashion, if the information in recorder, 16, is to be conveyed to more than one remote sites.

The controller, 20, can shut off any element or elements of the apparatus in whole or in part. It is interactive with external sources via telephone connection, 22, and can be reprogramed from such remote sources. It follows standard password protection techniques well known in the art.

Operation of Signal Processor Apparatus

The simplest forms of signal processor apparatus are each of the five paths described in FIGS. 2A, 2B, and 2C. Each path, by itself, is capable of identifying signals in the portions of programing transmissions that each receives. A digital signal is embedded by conventional generating and encoding means and transmitted in a television, radio or other transmission. Each path is capable of receiving a transmission or a portion of a transmission and detecting digital signals in that portion and transmitting said signals to in-line equipment for further processing. Each of the paths described in FIGS. 2A, 2B, and 2C can identify and process only signals embedded in the particular transmission channel inputted to said paths.

The signal processor apparatus described in FIG. 1 can identify such signals in multiple and variable locations in multiple and variable modes, channels, and transmissions. Such signals may be transmitted over and over continuously in such transmissions or they may be transmitted over and over only for predetermined time intervals. The controller, 20, is programed to sequence the local oscillator, 6, to select each desired frequency for a specific time interval in accordance with a predetermined pattern. This pattern may be selected in accordance with standard broadcast and cablecast practices known to exist on that transmission line or frequency. The local oscillator, being thus sequenced, will allow each signal decoder, 30 and 40, to receive a particular frequency at a particular time interval. This will define the timing of the composite outputs of the digital detectors, 34, 37, and 38 in FIG. 2A, and 43 in FIG. 2B. The same controller will control buffer/comparator, 8, to discard received duplicate and partial signals, to mark signals with correct channel identifiers, to transfer signals to decrypter, 10, and processor or monitor, 12, as required, and to perform such other functions as buffer/comparator, 8, performs. The controller, 20, instructs decrypter, 10, what to decrypt and in what fashion. It instructs processor or monitor, 12, how to identify what signals to pass externally and where to pass them and what signals to transfer to buffer/comparator, 14. The controller, 20, instructs buffer/comparator, 14,

what signals to discard and how to mark signals and assemble signal strings. The controller activates digital recorder, 16, thus defining the location in memory of each of the signals and signal strings. The controller, 20, also controls the automatic telephone dialing device, 24, which can automatically output the digital information on the digital recorder, 12, to a remote site through a telephone connection, 22. The controller, 20, can also set the proper time into clock, 18, should this step be necessary. The controller, 20, operates in a predetermined fashion that can be altered by external means communicating by means of the telephone connection, 22.

Method of Use at an Intermediate Transmission Point

The signal processing apparatus outlined in FIGS. 1, 2A, 2B, and 2C, and their variants as appropriate, can be used to automate the operations of an intermediate transmission point whether it be a broadcast station transmitting only a single channel of programing or a cable system cablecasting many channels. They can be used in a facility transmitting television programing, radio programing, and making other electronic transmissions.

FIGS. 3A, 3B and 3C illustrates one instance of such use. FIGS. 3A, 3B and 3C illustrate the use of Signal Processing Apparatus and Methods at a cable television system "head end" transmission facility that cablecasts several channels of television programing. The means for and method of transmission of programing described here is well known in the art. The facility receives programing from many sources. Transmissions may be received from satellites by satellite antenna, 50, low noise amplifiers, 51 and 52, and TV receivers, 53, 54, 55, and 56. Microwave transmissions can be received by microwave antenna, 57, and television video and audio receivers, 58 and 59. Conventional TV broadcast transmissions can be received by antenna, 60, and TV demodulator, 61. Other electronic programing input means, 62, can receive programing transmissions. All of these received transmissions feed into the facility by hard-wire and connect, by means of conventional switches (here matrix switch, 75), to one or more video recorder/players, 76 and 78, and/or to equipment that outputs them over various channels to the cable system's field distribution system, 93, which equipment includes here cable channel modulators, 83, 87, and 91, and channel combining and multiplexing system, 92. Programing can also be manually delivered to the facility on prerecorded video tapes and videodiscs. When played on video recorder and players, 76 and 78, or other similar equipment well known in the art, such prerecorded programing can be transmitted to the field.

In the present art, the identification of incoming programing, however received; the operation of video player and recorder equipment, 76 and 78; and the maintenance of records of programing transmissions are all largely manual operations.

FIGS. 3A, 3B and 3C show the introduction of signal processing apparatus and methods to automate these and other operations.

Incoming programing transmissions are received at the relevant receiver points, antennas, 50, 57, and 60, and other means, 62. They are fed along the conventional paths described above. At distribution amplifiers, 63 through 70, each incoming feed is split into two paths. One is the conventional path whereby programing has flowed and continues to flow to recording devices, 76 and 78, and/or to flow to field distribution

system, 93. The other path flows from each distribution amplifier, 63 through 70, individually to signal processor, 71. Signal processor, 71, has means, described above, to identify and separate the instruction and information signals from their associated programing and pass them, along with information identifying the channel source of each signal, externally to code reader, 72. Signal processor, 71, also has means to record said signals and transfer them to external communications network, 97. It also has means to record and transfer simultaneously.

Code reader, 72, passes the received signals, with channel identifiers, to cable program controller and computer, 73.

Cable program controller and computer, 73, is the central automatic control unit for the transmission facility.

The controller/computer, 73, has means for receiving input information from local input, 74, and from remote sources via telephone or other data transfer network, 98. Such input information might include the cable television system's complete programing schedule, with each discrete unit of programing identified with a unique program code (which in the case of advertising might be a purchase order number). Such input information might also indicate when and where the cable head end facility should expect to receive the programing. Such input information might also indicate when and on which channel or channels the head end facility should transmit each program unit to cable field distribution system, 93.

By means of the signals, with channel indicators, received from code reader, 72, controller/computer, 73, can determine what specific programing and programing unit has been received by each receiver, 53 through 62, and is passing in line on each individual wire to matrix switch, 75.

By comparing identification signals on the incoming programing with the programing schedule received earlier from local input, 74, and/or from a remote site via network, 98, controller/computer, 73, can determine when and on what channel or channels the head end facility should transmit the programing.

Controller/computer, 73, has means for communicating control information with matrix switch, 75, and video recorder/players, 76 and 78. If incoming programing is meant for immediate transmission, controller/computer, 73, instructs matrix switch, 75, to configure its switches so as to transfer incoming programing to the proper output channel. For example, if controller/computer, 73, determines that programing incoming via receiver, 53, should be transmitted immediately to the field distribution system, 93, via cable channel modulator, 87, controller/computer, 73, instructs matrix switch, 75, to configure its switches so as to transfer programing transmissions inputted from TV receiver, 53, to the output that leads to modulator, 87. Similarly, if controller/computer, 73, determines that incoming programing should be recorded for delayed transmission, controller/computer, 73, selects a video recorder/player, 76 or 78, in a predetermined fashion, to record the incoming programing, instructs matrix switch, 75, to transfer the programing to the designated recorder/player, 76 or 78, and instructs the recorder/player, 76 or 78, to turn on and record the programing.

Recorder/players, 76 and 78, can communicate programing with each other through matrix switch, 75. If controller/computer, 73, determines at any time that it

is necessary to reorganize the order in which programing units are stored on either recorder/player or on both, controller/computer, 73, can use techniques for reorganizing files stored on multidisk units, which techniques are well known to computer operators, and order the execution of such techniques by passing appropriate instructions to of matrix switch, 75, and recorder/players, 76 and 78. Were this head end facility equipped with automatic operating equipment well known in television studios, controller/computer, 73, could pass appropriate operating instructions to such equipment.

Controller/computer, 73, monitors the operation of the head end facility by means of TV signal decoders, 77, 79, 80, 84, and 88, each of which are shown in detail in FIG. 2A. Controller/computer, 73, has means to communicate control information with each decoder, 77, 79, 80, 84, and 88, to tell each how to operate and how and where to look for signals and to communicate other information. (This particular embodiment could be expanded to include a decrypter, such as decrypter 10 in FIG. 1, in signals-only line between each decoder, 77, 79, 80, 84, and 88, and controller/computer, 73.) Decoders, 80, 84, and 88, inform controller/computer, 73, what programing is passing on each cable channel and what signals the programing contains. Decoders, 77 and 79, inform controller/computer, 73, what specific programing is loaded on recorder/players, 76 and 78 respectively, and what signals it contains. (Among other signals, a program unit could contain signals that would inform controller/computer, 73, of the distance to the beginning and end of the program unit which signals would facilitate operation of recorder/players such as 76 and 78.)

The cable head end facility also contains signal strippers, 81, 85, and 89, of which models exist well known in the art, that controller/computer, 73, can instruct to remove signals from programing as required, and signal generators, 82, 86, and 90, also well known in the art, that controller/computer, 73, can instruct to add signals to programing as required. At each point, 81, 85, and 89, there may be single or multiple strippers. At each point, 82, 86, and 90, there may be single or multiple generators.

Beyond channel combining system and multiplexer, 92, amplifier, 94, transmits programing to signal processor, 71, and signal processor, 96, which permits both apparatus to monitor and record all the programing transmitted by the cable television system head end facility to field distribution system, 93. Such records can provide automatically for each channel the information that the Federal Communications Commission requires broadcast station operators to maintain as station logs. Signal processors, 71 and 96, can transmit such records of programing to remote sites via telephone or other data transfer networks, 97 and 99 respectively.

This particular embodiment describes a transmission facility transmitting only television programing. The facility could also process and transmit radio programing and other electronic data according to the methods described here by adding radio decoder paths and other signal decoder paths, as shown in FIGS. 2B and 2C respectively, to signal processors, 71 and 96, and decoders, 77, 79, 80, 84, and 88. Likewise, these methods are also applicable in a facility that transmits only a single channel of radio or television programing.

Methods for Governing the Reception of Programing

FIGS. 4A through 4E illustrate methods for governing the reception of programing and the use of signal processor apparatus in these methods. All of these methods involve the use of one or more devices, of which various models exist well known in the art, for the decryption of programing transmissions and/or one or more other means for interrupting programing transmissions, also well known in the art, which may be as simple as a switch and which may have means to interrupt programing by generating noise which noise may be an overlay of another audio and/or video transmission.

FIG. 4A shows a signal processor, 100, and a programing decrypter and/or interrupt means, 101, each of which receives the same transmission of programing. The devices, 100 and 101, may receive one channel of programing or multiple channels. The signals that enable the decrypter/interrupter, 101, to decrypt and/or transfer programing uninterrupted may be embedded in the programing or may be elsewhere. Signal processor, 100, identifies, evaluates, possibly decrypts, and passes a signal or signals to decrypter/interrupter, 101, either at the time of receipt of such programing or at a delayed time or a combination. The signal or signals instruct decrypter/interrupter, 101, to decrypt the transmission or not to decrypt the transmission or to interrupt the transmission or not to interrupt the transmission. The signal or signals may also inform decrypter/interrupter, 101, how to decrypt or interrupt the programing if decrypter/interrupter, 101, is capable of multiple means. The signal or signals may transmit a code or codes necessary for the decryption of the transmission.

FIG. 4A also shows local input, 102, with means for generating and transmitting signals to signal processor, 100. Local input, 102, is intended to permit a person at a local receiving site that is prevented, by any means, from receiving programing to instruct signal processor, 100, that the site wants to be enabled to receive the programing. Local input, 102, may also serve other purposes. Local input, 102, may convey a continuous signal or an occasional signal or a one-time-only signal. It may be activated by one or more switches or buttons or combinations. It may be a computer acting in a predetermined fashion. The signal may be input to signal processor, 100, as described in FIG. 1, at buffer/comparator, 8, or signal processor or monitor, 12, or buffer/comparator, 14.

In the preferred embodiment, local input, 102, inputs a one-time signal to signal processor, 100, at buffer/comparator, 8, and transmits information in a digital code signal which information is input to local input, 102, in an alphanumeric form manually by means of buttons.

FIGS. 4B and 4C illustrate various alternative ways that signals may be input to the signal processor, 100, 103, or 106 as applicable. The fundamental point is that signals may be received in a manner that requires decryption and/or transmission by a decrypter/interrupter, 104, before they reach the signal processor, as with signal processor 103 in FIG. 4B, or they may not, as with signal processor 100 in FIG. 4A, or some combination, as with signal processor 106 in FIG. 4C.

However, FIGS. 4A, 4B, and 4C do not fully illustrate this point because these figures do not reveal that the question of the need for decryption prior to reaching the signal processor depends, among other things, on where the signal or signals are placed in the incoming transmission. A decrypter does not necessarily de-

crypt the entire transmission. Encrypted transmissions may be only partially encrypted. For example, only the video portion of the transmission may be encrypted. The audio portion may remain unencrypted. In such a circumstance, a connection such as that shown in FIG. 4B could pass unencrypted signals to signal processor 103, while passing a transmission unsuitable for satisfactory viewing, if the signals were placed in the audio portion of the overall transmission.

FIG. 4C illustrates a configuration that permits a method that provides a signal or signals to signal processor, 106, prior to decryption which signal or signals enables decrypter/interrupter, 107, to decrypt and/or pass programing transmissions it receives then signal processor, 106, searches in a predetermined fashion for a second signal or set of signals in the decrypted output of decrypter/interrupter, 107. If this second signal or set of signals fails to appear in the form or forms and place or places and time or times that signal processor, 106, expects, signal processor, 106, can respond in a predetermined fashion and generate and record in digital recorder, 16 (referring to FIG. 1), information that reports this fact in a predetermined fashion and/or transfer this information immediately to a remote site by telephone means and/or generate and transmit to decrypter/interrupter, 107, instructions that disable decrypter/interrupter, 107.

FIG. 4D shows that a multi-stage decryption/interruption process may be used in which transmissions must be processed by one or more additional decrypter/interrupters, 111, that follow decrypter/interrupter, 110.

FIG. 4E illustrates that the signal processor, 112, can monitor multiple channels and pass instructions to multiple decrypter/interrupters, each of which processes fewer channels than the multiple channels processed by signal processor, 112. FIG. 4E illustrates how signals transmitted on one channel can govern the decryption and/or transfer of another channel. Signal processor, 112, receives, evaluates, and processes a multiple channel transmission from cable transmission facility, 113. Cable converter box, 114, of which many types are now available, with means for informing signal processor, 112, which channel of programing it is transferring, receives the same multi-channel transmission and transfers one channel to decrypter/interrupter, 115. The signal or signals necessary for the decryption of the channel that box, 114, passes to decrypter/interrupter, 115, in this case, is not located in the channel transmission. They may be preprogramed into the signal processor (for example, in programable random access memory controller, 20, in FIG. 1) or they may be transmitted in a channel other than the channel being transferred from box, 114. If signal processor, 112, has been preprogramed with the signal or signals or if it has been informed of the predetermined fashion for identifying and processing the the needed signal or signals in the incoming transmission from facility, 113, for example, where to look for the signals and when and how, signal processor, 112, can transfer the signal to decrypter/interrupter, 115. The tuner, 119, informs signal processor, 112, what channel box, 114, is switched to whenever box, 114, is switched or turned on. Signal processor, 112, receives this information probably at buffer/comparator, 8 (referring to FIG. 1), which signal processor, 112, processes the signal from tuner, 119, in a predetermined fashion that causes the signal or signals that relate to the necessary proper operation of decrypter/interrupter,

115. If signal processor, 112, can identify, processes, and transfer the needed signal or signals, decryptor/interruptor, 115, can decrypt and/or transfer the incoming transmission from box, 114, satisfactorily. If signal processor, 112, cannot transfer the needed signal or signals, decryptor/interruptor, 115, cannot decrypt and/or transfer the programming transmission satisfactorily.

FIG. 4E also illustrates how it may be necessary to decrypt a programming transmission on one channel in order to identify and process correctly the programming transmitted on another. In FIG. 4E, the signal or signals needed to operate decryptor/interruptor, 115, correctly may be on a separate channel of programming that is, itself, encrypted in transmission. Signal processor, 112, can transfer the correct signal or signals only if cable converter box, 117, is tuned to the proper channel and decryptor/interruptor, 118, can transfer a correctly decrypted transmission to signal processor, 112, for processing.

In any of the cases illustrated in FIGS. 4A through 4E, signal processors, 100, 103, 106, 109, and 112, could also operate in a predetermined fashion and telephone a remote site to get an additional signal or signals necessary for the proper decryption and/or transfer of incoming programming transmissions.

Methods for Monitoring Reception and Operation

FIG. 5 illustrates methods for monitoring reception and operation which methods can be used to gather statistics on programming usage and associated uses of other data transmissions and equipment. Such statistics are necessary, for example, in the development of television program ratings.

FIG. 5 shows two conventional TV sets, 132 and 144, a conventional video cassette recorder, 135, a conventional videodisc player, 137, a conventional radio, 141, a conventional microcomputer, 142, a conventional data printer, 146, and a television set, 148, that is capable of displaying two different television programming transmissions at once. This is only a representative group of equipment. Many other types of television and radio players and recorders could be included in FIG. 5.

Except for the videodisc player which neither records nor displays programming or other data, each unit has an appropriate associated signal decoder. Each decoder is likely to be located physically inside its associated player/recorder unit. Each is located at a point in the associated unit's circuitry where it receives every embedded signal on the programming channel or data channel to which the unit is tuned for which signal the decoder is programmed in a predetermined fashion to search.

If a unit like the microcomputer can receive transmissions from more than one source or of more than one kind—television, radio, or other—it will have sufficient apparatus to monitor every channel and kind of transmission it can receive.

The signals for which the decoders are monitoring are likely to be unique digital codes that may identify each programming or data unit received and the source of each. They may identify networks, broadcast stations, channels on cable systems, and possibly times of transmission. They may convey unique identifier codes for each program or commercial. In the case of data transmitted to the microcomputer, they may be unique codes that identify the source and suppliers of the data. In the case of data received at the printer, they may identify publications, articles, publishers, distributors, advertisements, etc. The decoders, 131, 136, 138, 143, 145, 147,

149, and 150, may search for many types of codes, and the types described here provide only examples.

In FIG. 5, each decoder receives every relevant signal received by its associated player or recorder unit. For example, TV set, 131, may receive programming from many sources including cable converter box, 133, video cassette recorder, 135, and videodisc player, 137. In every programming unit played on TV set, 132, TV decoder, 131, receives every signal for which it is instructed to search in a predetermined fashion and transfers the signals to signal processor, 130, which has means to identify the source decoder from which each signal that it receives comes. On all programming recorded by video cassette recorder, 135, decoder, 136, receives every relevant signal and transfers such signals to signal processor 130. Radio signal decoder, 138, operates similarly for radio, 141. Other signal decoder, 143, for microcomputer 142. TV signal decoder, 145, for TV set, 144 (which may receive programming inputs and associated signals generated or transferred by microcomputer, 142). Other signal decoder, 147, for printer 146. And TV signal decoders, 150 and 149, for each channel of programming received and displayed by multi-picture TV set, 148.

One particular advantage of these methods for monitoring programming is that, by locating the identifier signals in the audio and/or video and/or other parts of the programming that are conventionally recorded by, for example, conventional video cassette recorders, these methods provide techniques for gathering statistics on what is recorded on video cassette recorders and on how people replay such recordings. For example, a person might instruct video cassette recorder, 135, automatically to record the NBC Network Nightly News as broadcast over station WNBC in New York City. Recorder, 135, might receive the programming over Manhattan Cable TV channel 4 and record the programming from 7:00 PM to 7:30 PM on the evening of July 15, 1985. Each discrete bit of this information could be conveyed to recorder, 135, in a signal unit or units in the programming so received and recorded. Decoder, 136, would identify these signals and transfer them to signal processor, 130. Subsequently, the person might play the recorded programming on TV set, 132, from 10:45 PM to 11:15 PM the same evening. This time, TV signal decoder, 131, identifies the embedded signals and transfers them to signal processor, 131. Prerecorded video cassettes and videodiscs could also contain unique embedded codes that would identify their usage (and could also transfer instructions to other external equipment).

Signal processor, 130, would probably receive these signals from decoders, 131, 136, 138, 143, 145, 147, 149, and 150) at its buffer/comparator unit, 14 (referring to FIG. 1), in a predetermined fashion that would permit signal processor, 130, to identify which decoder the individual signals come from and, in a predetermined fashion, create a signal string by appending digital information to the received signal which information might identify the individual decoder, 131, 136, 138, 143, 145, 147, 149, or 150 and the time of receipt at signal processor, 130. To minimize the use of data recorder, 16, buffer/comparator, 14, may evaluate signals in a predetermined fashion and discard some signals rather than passing them to the recorder, 16. It may compare each signal from a given source such as decoder, 131, with other signals received earlier from the same source. It may only count incoming duplicate signals or it may append a time code to the end of the basic signal string

formed around the first received signal and alter this time designation each time a new duplicate signal is identified so that the time code identifies the time of receipt of the last duplicate signal. Whatever method is used, the buffer/comparator, 14, may discard all duplicate signals received. At a time when buffer/comparator, 14, determines in a predetermined fashion that it will receive no further duplicate signals, it transfers the full signal string to recorder, 16.

Signal divider, 139, illustrates another type of monitoring that signal processing apparatus and methods can facilitate. Signal divider, 139, monitors the use of signals rather than the use of programing. Every instruction or information signal transmitted from processor, 140, to microcomputer, 142, is also transmitted to signal processor, 130, to be handled, recorded, and transmitted to a remote site with all other monitor information. In a predetermined fashion, signal processor, 130, identifies and marks the source of signals as coming from a device, 139, monitoring signal usage rather than programing usage and viewership. In this fashion, besides facilitating data gathering on how programing is used, signal processing apparatus and methods also permit the evaluation of how equipment is used.

(For simplicity, FIG. 5 has focused only on methods whereby data is gathered from signal decoders remote from signal processor, 130. FIG. 5 has not included control information connections between signal processor, 130, and the remote decoders which would permit signal decoder, 130, to alter the methods of operation of said remote decoders. Such control information connections are included in signal processing apparatus and methods.)

Methods for Governing or Influencing the Operation of Equipment that is External to Conventional Television and Radio Sets by Passing Instruction and Information Signals that are Embedded in Television and Radio Programing Transmissions to Such External Equipment

Signal processor apparatus have the ability to identify instruction and information signals in one or more inputted television and radio programing transmissions, identify and discriminate among one or more pieces of external equipment to which such signals are addressed, and transfer such signals to such equipment as directed. This permits many valuable techniques for facilitating the operation of such external equipment.

FIGS. 6A and 6B illustrate one possible configuration of equipment in a home or office or other television and/or radio receiving site. Consideration of FIGS. 6F and 6G is facilitated by consideration, first, of individual examples of the types of co-ordinated presentations that the signal apparatus and methods described here can permit.

Governing the Home or Office Environment

FIG. 6A illustrates a method for governing a home or office environment. One or more channels of television programing transmissions inputted to signal processor, 200, and cable converter box, 201, may contain signals intended for microcomputer, 205, which signals convey information on local weather conditions. Such signals might include current outside temperature and barometric readings. They might include forecast data. Signal processor, 200, is always operating and monitors all incoming channels. It can convey such signals to microcomputer, 205, whenever it receives them. TV signal decoder, 203, can also identify such signals but only in the one TV channel transferred by box, 201, to TV set, 202, and then only when TV set, 202, is on and

operating. Decoder, 203, transfers all received signals to processor or monitor, 204, which identifies the signals as addressed to microcomputer, 205, and transfers them to microcomputer, 205. Microcomputer, 205, uses such received signals, in a predetermined fashion, to govern the operation of furnace, 206, air conditioning system, 207, and window opening and closing means, 208.

Co-ordinating a Stereo Simulcast

FIG. 6B illustrates a method for automatic co-ordination of a multimedia presentation in one place, in this case a stereo simulcast. A person decides to watch a program on television that is stereo simulcast on a local radio station, too. The person turns on television, 202, and tunes to the proper channel. TV signal decoder, 203, detects signals in the programing transmission on the channel which signals it transfers to monitor or processor, 204. Monitor or processor, 204, determines that certain signals are addressed to switch, 212, and transfers these signals to switch, 212. These signals instruct switch, 212, to turn power on to radio, 209, and its associated equipment, including a conventional digital tuner, 213. Monitor or processor, 204, also identifies signals addressed to tuner, 213, which it transfers accordingly. These signals instruct tuner, 213, to tune radio, 209, to the proper frequency for the simulcast. Automatically, by turning TV set, 202, to the channel with a stereo simulcast, the person has activated the stereo simulcast.

FIG. 6B also shows signal processor, 200, monitoring for a data gathering and ratings service. TV signal decoder, 203, and radio signal decoder, 211, also identify certain signals that monitors or processors, 204 and 210 respectively, determine to identify the programs, etc. on the channels to which TV set, 202, and radio, 209, are tuned. The processors, 204 and 210, transfer this information to signal processor, 200, for recording and subsequent transmission to a remote data collection site. Simultaneously, processor, 200, is also monitoring sequentially all other broadcast transmissions in the locality to gather further data on programing availability to record and transmit to a remote site.

Receiving Selected Information and/or Programing

FIG. 6C illustrates methods for monitoring multiple programing channels and selecting programing and information in a predetermined fashion. In this example, microprocessor, 205, is programed to hold a portfolio of stocks and to receive news about these particular stocks and about the industries they are in. Several separate news services transmit news on different channels carried on the multi-channel cable transmission to converter boxes, 222 and 201, and to signal processor, 200. The news services precede each news transmission with a unique signal that uniquely identifies the company or companies to which the news item refers and/or the industries. In a predetermined fashion, microcomputer, 205, instructs signal processor, 200, to hold examples of the sought for unique signals in its buffer/comparator, 8, and compare them with all incoming signals. Signal processor, 200, scans sequentially all channels. When it identifies a signal of interest, it relays that information and the channel identifier, in this illustration, to microcomputer, 205. In a predetermined fashion, either microcomputer, 205, or signal processor, 200, instructs tuner, 223, to set cable converter box, 222, to the proper channel, and microcomputer, 200, may record the information in memory or transfer it to printer, 221, for printing.

In the same fashion, microcomputer, 205, may also instruct signal processor, 200, to monitor single or multiple television channels and/or radio channels for programing of interest to play or record.

In another example, microcomputer, 205 may be preinformed that a certain television program, hypothetically "Wall Street Week," should be televised on TV set, 202, when it is cablecast. Microcomputer, 205, is preinformed of the time of cablecasting. When that time comes, microcomputer, 205, receives no program identification signals whatever from TV signal decoder, 203, which indicates that the set, 202, is not on. Microcomputer, 205, instructs signal processor, 200, to pass all program and channel identifiers on all programing being cablecast on the multi-channel system. Signal processor, 200, receives this instruction from microcomputer, 205, at its processor or monitor, 12, which reacts, in a predetermined fashion by passing also externally to microcomputer, 205, all signals that it passes to buffer/comparator, 14. Analyzing these identifier signals in a predetermined fashion, microcomputer, 205, determines that "Wall Street Week" is being televised on channel X. Then, in a predetermined fashion, microcomputer, 205, may instruct tuner, 214, to switch box, 201, to channel X and may instruct control system, 220, to turn video recorder, 217, on and record "Wall Street Week," and also microcomputer, 205, may instruct switch, 216, to turn TV set, 202, on and tuner, 215, to tune appropriately to "Wall Street Week."

Co-ordinating Multimedia Presentations in Time

FIG. 6C can also illustrate how programing delivered at different times to one place can be co-ordinated to give a multimedia presentation at one time in one place.

Each weekday, microcomputer, 205, receives, about 4:30 PM, by means of a digital information channel, all closing stock prices applicable that day. It may receive these directly or it may automatically query a data service for them in a predetermined fashion. It records those prices that relate to the stocks in its stored portfolio.

Microcomputer, 205, is preprogramed to respond in a predetermined fashion to instruction signals embedded in the "Wall Street Week" programing transmission. When the "Wall Street Week" transmission begins at 8:30 PM on a Friday evening, several instruction signals are identified by decoder, 203, and transferred to microcomputer, 205. These signals instruct microcomputer, 205, to generate several graphic video overlays, which microcomputer, 205, has the means to generate and transmit and TV set, 202, has the means to receive and display, and to transmit these overlays to TV set, 202, upon command. Subsequently in the program, the host says, "Here is what the Dow Jones Industrials did is the past week," and a studio generated graphic is pictured. The host then says, "Here is what the broader NASDAQ index did in the week past," and a studio generated graphic overlay is displayed on top of the first graphic. Then the host says, "And here is what your portfolio did." At this point, an instruction signal is generated in the television studio originating the programing and is transmitted in the programing transmission. This signal is identified by decoder, 203, and transferred via processor, 204, to microcomputer, 205. This signal instructs microcomputer, 205, to transmit the first overlay to TV set, 202, for as long as it receives the same instruction signal from processor, 204. The viewer then sees a microcomputer generated graphic of his

own stocks' performance overlay the studio generated graphic. When the two studio generated graphics are no longer displayed, the studio stops sending the instruction signal, and the microcomputer, 205, ceases transmitting its own graphic to TV set, 202, and prepares to send the next locally generated graphic overlay upon instruction from the originating studio.

This is only one of many examples of the co-ordination at one time and in one place of programing and information material delivered at different times.

Co-ordinating Print and Video

FIG. 6D illustrates one method for co-ordinating the presentation of information through the use of print with video. FIG. 6D also illustrates possible uses of a decrypter and a local input.

Suppose a viewer watches a television program on cooking techniques that is received on TV set, 202, via box, 201. Julia Childs's "The French Chef" is one such program. Halfway through the program, the host says, "If you are interested in cooking what we are preparing here and want a printed copy of the recipe for a charge of only 10 cents, press 567 on your Widget Signal Generator and Local Input." The viewer then presses buttons 567 on local input, 225, which signal is conveyed to the buffer/comparator, 8 (referring to FIG. 1), of signal processor, 200, to hold and process further in a predetermined fashion. Five minutes later, a signal is identified in the incoming programing on TV set, 202, by decoder, 203, which is also transferred by processor, 204, to buffer/comparator, 8, of signal processor, 200. This signal instructs buffer/comparator, 8, that, if 567 has been received from signal generator, 225, signal processor, 200, should, in a predetermined fashion, instruct tuner, 223, to tune cable converter box, 222, to the appropriate channel to receive the recipe in encoded digital form and instruct control means, 226, to activate printer, 221. The signal transmission from processor, 204, also passes a signal word to signal processor, 200, which, in a predetermined fashion, signal processor, 200, decrypts and transfers to decrypter, 224, to serve as the code upon which decrypter, 224, will decrypt the incoming encrypted recipe. Then, as part of the predetermined operation, signal processor, 200, conveys to its data recorder, 16, information that the 567 order was placed by the viewer and all necessary equipment was enabled. When the transmission of the recipe is received, box 222, transfers the transmission to decrypter, 224, for decryption and thence to printer, 221, for printing. Other signal decoder, 227, identifies a signal in the transmission received by printer, 221, which it passes via processor, 228, and buffer/comparator, 14, of signal processor, 200, to data recorder, 16. This signal indicates that the recipe, itself, has been received. Subsequently, when signal processor, 200, transfers the data in its data recorder, 16, via telephone to a remote site, that site can determine for billing purposes that the recipe was, first, ordered and, second, delivered.

(An alternate method for transmitting the recipe to printer, 221, would be for the recipe, itself, to be located in encoded digital form in the programing transmission received by TV set, 202. In this case, decoder, 203, would identify the signals conveying the recipe and transfer them via processor, 204, to signal processor, 200, which would decrypt them, itself, and transfer them, via means which in this case it would have, to printer, 221.)

Using Signaling and Decryption Techniques to Control Distribution of Copyrighted Materials

FIG. 6E illustrates a signaling and decryption technique which could serve to facilitate the electronic distribution of copyrighted materials such as books and movies by tending to discourage piracy and the unauthorized retransmission of copies, whether they be properly acquired or pirated.

FIG. 6E could be any home or commercial establishment but is described here as a book store. Using conventional laser videodisc equipment and techniques, well known in the art, a publisher has put his full line of books on laser discs in encrypted form and distributed one copy of each disc to each of his authorized book store retail outlets. He has also distributed to each a conventional computer floppy disk for use on conventional microcomputer, 205, that can operate conventional laser videodisc system, 232, in a predetermined fashion to locate and transmit individual titles in his line.

A customer comes into the book store and asks to buy a title, hypothetically, *How to Grow Grass*. The salesman asks the customer for suitable identification, types into microcomputer, 205, the customer's name and address and that he wishes to purchase *How to Grow Grass*. Microcomputer, 205, may check to determine that the customer has no record as a pirate then transfers his name and address to buffer/comparator, 8 (referring to FIG. 1), of signal processor, 200, and instructs laser videodisc system, 232, to transmit its encrypted copy of *How to Grow Grass* to printer or other means, 221, via decryptors, 224 and 231. Laser system, 232, transmits one copy of the encrypted title to decryptor, 224, and one to signal processor, 200, for processing and evaluation.

In the encrypted title, signal processor, 200, identifies one or more signal words. If signal processor, 200, has the customer's name and address and the bookstore is a retail outlet in good standing that has received from a remote site program information on the predetermined fashions in affect, signal processor, 200, decrypts the signal word or words and transfers them to decryptor, 224, to serve as the code for the first stage of decryption.

Decryptor, 224, then decrypts a part of the encrypted transmission and passes the partly decrypted transmission to signal stripper, 229, and signal generator, 230. In the decrypted portion of the partially decrypted transmission, signal processor, 200, identifies a second signal word or set of words which it decrypts in a predetermined fashion and passes to decryptor, 231, to serve as the code basis for the second stage of decryption. Signal processor, 200, also may instruct signal stripper, 229, to remove this second signal word or words. Signal processor, 200, also passes the customer's name and address and its own unique apparatus identifier code from read only memory, 21, to signal generator, 230, which generates a signal embedding the customer's name and address and the retail outlet's identification in the programming in a suitable place or places in a suitable fashion. (Signal processor, 200, may also transmit the customer's name and address to printer or other means, 221, for actual printing of the customer's name and address in the text.) The transmission then passes through decryptor, 231, which completes the decryption process and passes the decrypted programming transmission to printer or other means, 221, and also to signal processor, 200. Signal processor 200, receives and analyzes the signal content of the programming output of

decrypter, 231 to ensure that stripper, 229, and and generator, 230, have functioned properly. If they have not, signal processor, 200, shuts down the decryption of the title and prevents its delivery to the customer.

5 The General Case

It is obvious to one of ordinary skill in the art that the foregoing is presented by way of example only and that the invention is not to be unduly restricted thereby since modifications may be made in the structure of the various parts without functionally departing from the spirit of the invention. FIG. 6 should make this clear. The receiver site depicted in FIG. 6 has multiple means for receiving programming transmissions. All received programming is analyzed and evaluated by signal processor, 200. Working with microcomputer, 205, which is preprogrammed to present received programming in predetermined fashions determined at the receiver site, signal processor, 200, permits and facilitates such presentations in accordance with the intentions of the suppliers of the programming at remote sites. Working together, signal processor, 200, and microcomputer, 205, can control all local equipment and manage local presentations in any fashion feasible given the nature of the local equipment and the programming.

We claim:

1. A method of communicating television program material to a multiplicity of receiver stations each of which includes a television receiver and computer, the computers being adapted to generate and transmit overlay signals to their associated television receivers, said overlay signals causing the display of user specific information related to said program material, and with at least some of said computers being programmed to process overlay modification control signals so as to modify the overlay signals transmitted to their associated receivers, each of said computers being programmed to accommodate a specific user application, comprising the steps of:

transmitting a video signal containing a television program signal to said receivers,
 transmitting an instruct-to-overlay signal to said receiver stations at a time when the corresponding overlay is not being displayed,
 receiving said video signal at a plurality of receiver stations and displaying said program material on the video receivers of selected ones of said plurality of receiver stations,
 detecting the presence of said instruct-to-overlay signal at said selected receiver stations and coupling said instruct-to-overlay signal to the computers associated with the video receivers of said selected stations, and
 causing said last named computers to generate and transmit their overlay signals to their associated television receivers in response to said instruct-to-overlay signal, thereby to present a display at the selected receiver stations including the television program material and the related computer generated overlay, the overlays displayed at a multiplicity of said receiver stations being different, with each display specific to a specific user.

2. A method according to claim 1, further including the step of transmitting an overlay modification signal to the computers which are programmed to process overlay modification signals, and causing said last named computers to modify their respective overlay signals in response thereto.

3. A method according to claim 1, wherein said instruct-to-overlay signal is embedded in said video signal outside the range of the television picture.

4. In a method of communicating television program material to a multiplicity of receiver stations each of which includes a television receiver and computer, the computers being adapted to generate and transmit overlay video signals to their associated television receivers, said overlay signals causing the display of user specific information related to said program material, and with at least some of said computers being programmed to process overlay control signals transmitted to their associated receivers, each of said computers being programmed to accommodate a unique user application, the steps of

transmitting a video signal containing a television program signal to said receiver stations, and transmitting an instruct-to-overlay signal at a time when the corresponding overlay is not being displayed to thereby cause selected ones of said computers to generate and transmit their overlay signals to their associated television receiver to present a combined display consisting of the television program and the related computer generated overlay, the overlays displayed at a multiplicity of said receiver stations being different, with each display unique to a specific user.

5. A process according to claim 4, further including the step of transmitting an overlay modification signal to the computers which are programmed to process overlay modification signals.

6. A method according to claim 4, wherein said instruct-to-overlay signal is embedded in said video signal outside the range of the television picture.

7. In a method of communicating television program material to a multiplicity of receiver stations each of which includes a television receiver and computer, the computers being adapted to generate and transmit overlay video signals, to their associated television receivers, said overlay signals causing the display of user specific information related to said program material, and with at least some of said computers being programmed to process overlay modification control signals so as to modify the overlay video signals transmitted to their associated receivers, each of said computers being programmed to accommodate a specific user application, and wherein a video signal containing a television program signal and an instruct to-overlay signal are transmitted to said receiver stations, the steps of

receiving said video signal at a plurality of receiver stations and displaying said program material on the video receivers of selected ones of said plurality of receiver stations,

detecting the presence of said instruct-to-overlay signal at said selected receiver stations at a time when the corresponding overlay is not being displayed, and coupling said instruct-to-overlay signal

to the computers at said selected receiver stations, and

causing the computers at said selected receiver stations to generate and transmit their overlay video signals to their associated television receivers in response to said instruct-to-overlay signal, thereby to present a combined display at the selected receiver stations consisting of the television program and the related computer generated overlay, the overlays displayed at a multiplicity of said receiver stations being different, with each display specific to a specific user.

8. A method according to claim 7, further including the step of transmitting an overlay modification signal to the computers which are programmed to process overlay modification signals, and causing said last named computers to modify their respective overlay video signals in response thereto.

9. Television signal processor means, comprising carrier transmission receiving means, means for demodulating the output of said receiving means to detect a video program signal, means normally coupling said video signal to a television receiver, decoder means for determining the presence or absence of an embedded instruct-to-overlay signal in said video signal at a time when the corresponding overlay is not being displayed, computer means for generating and transmitting video overlay signals, said overlay signals causing the display of user specific information related to said program material, and means connected to said computer means and responsive to said decoder means when the presence of said embedded signal is detected for coupling said overlay signals to said television receiver, the overlays displayed at a multiplicity of said receiver stations being different, with each display specific to a specific user.

10. Television signal processor means according to claim 9, wherein said means connected to said computer means and responsive to said decoder means disconnects said video program signal from said television receiver upon detection of the absence of said embedded signal.

11. Television signal processor means according to claim 9, further including means coupled to said computer means for selectively updating said overlay signals.

12. Television signal processor means according to claim 11, wherein said embedded signal is a periodically recurring signal and wherein said means connected to said computer means and responsive to said decoder means couples said overlay video signals to said television receiver for so long as said embedded signal appears in said video program signal.

13. Television signal processor means according to claim 9, wherein said overlay video signal represents a graphic overlay.

* * * * *