



US006757717B1

(12) **United States Patent**
Goldstein

(10) **Patent No.:** **US 6,757,717 B1**
(45) **Date of Patent:** **Jun. 29, 2004**

(54) **SYSTEM AND METHOD FOR DATA ACCESS**

6,279,041 B1 * 8/2001 Baber et al. 709/232

(75) Inventor: **Leonid Goldstein, Herzlia (IL)**

OTHER PUBLICATIONS

(73) Assignee: **ProxyConn, Inc., Irvine, CA (US)**

RFC2068: Hypertext Transfer Protocol—HTTP/1.1, Jan. 1997, pp. 9–12, 29–35, 70–94, 101–138.

(*) Notice: Subject to any disclaimer, the term of this patent is extended or adjusted under 35 U.S.C. 154(b) by 0 days.

RFC791: Internet Protocol Darpa Internet Program Protocol Specification, Sep. 1981, pp. 3, 11–14, 26.

RFC761: DOD Standard Transmission Control Protocol, Jan. 1980, pp.4, 15–17.

(21) Appl. No.: **09/398,007**

RFC1826: IP Authentication Header, Aug. 1995, pp. 1–10.

(22) Filed: **Sep. 16, 1999**

RFC1864: The Content—MD5 Header Field, Oct. 1995, pp.1–2.

(51) **Int. Cl.**⁷ **G06F 15/16**

RFC1321: The MD5 Message—Digest Algorithm, Apr. 1992, pp. 1–21.

(52) **U.S. Cl.** **709/217; 707/1; 707/10; 709/203; 709/225; 709/229**

Dave Fogle, Ethernet Frame Types, article from Feb. 1996 issue of LAN Magazine/Network Magazine, pp. 1–4.

(58) **Field of Search** **709/217, 203, 709/229, 225; 707/10, 1**

W. Richard Stevens, TCP/IP Illustrated, vol. 1, 1994, pp. 33–37, 143–147, 223–228.

(56) **References Cited**

* cited by examiner

U.S. PATENT DOCUMENTS

Primary Examiner—Jack B. Harvey

Assistant Examiner—Hai V. Nguyen

(74) *Attorney, Agent, or Firm*—J. D. Harriman, II, Esq.; Coudert Brothers LLP

4,897,781 A	1/1990	Chang et al.	
5,384,565 A	1/1995	Gregory	
5,682,514 A	* 10/1997	Yohe et al.	707/1
5,732,265 A	3/1998	Dewitt et al.	
5,835,943 A	11/1998	Yohe et al.	
5,852,717 A	12/1998	Bhide et al.	
5,864,837 A	1/1999	Maimone	
5,878,213 A	* 3/1999	Bittinger et al.	707/10
5,909,569 A	* 6/1999	Housel et al.	707/10
5,919,247 A	* 7/1999	Van Hoff et al.	709/217
5,924,116 A	7/1999	Aggarwal et al.	
5,931,947 A	* 8/1999	Burns et al.	713/201
5,978,791 A	11/1999	Farber et al.	
6,003,087 A	* 12/1999	Housel et al.	707/203
6,006,034 A	12/1999	Heath et al.	
6,012,085 A	1/2000	Yohe et al.	
6,021,491 A	* 2/2000	Renaud	713/179
6,073,173 A	* 6/2000	Bittinger et al.	707/513
6,085,249 A	* 7/2000	Wang et al.	709/229
6,101,543 A	* 8/2000	Alden et al.	709/229
6,122,637 A	* 9/2000	Yohe et al.	709/204
6,134,583 A	* 10/2000	Herriot	709/217
6,148,340 A	* 11/2000	Bittinger et al.	709/203
6,256,664 B1	* 7/2001	Donoho et al.	709/204

(57) **ABSTRACT**

The invention provides a system for data access in a packet-switched network, including a sender/computer including an operating unit, a first memory, a permanent storage memory and a processor and a remote receiver/computer including an operating unit, a first memory, a permanent storage memory and a processor, the sender/computer and the receiver/computer communicating through the network; the sender/computer further including device for calculating digital digests on data; the receiver/computer further including a network cache memory and device for calculating digital digests on data in the network cache memory; and the receiver/computer and/or the sender/computer including device for comparison between digital digests. The invention also provides a method and apparatus for increased data access in a packet-switched network.

34 Claims, 9 Drawing Sheets

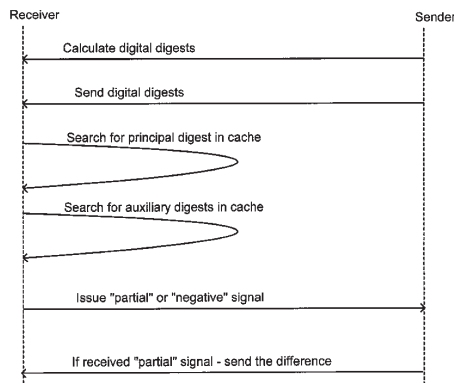

MICROSOFT
EXHIBIT 1002

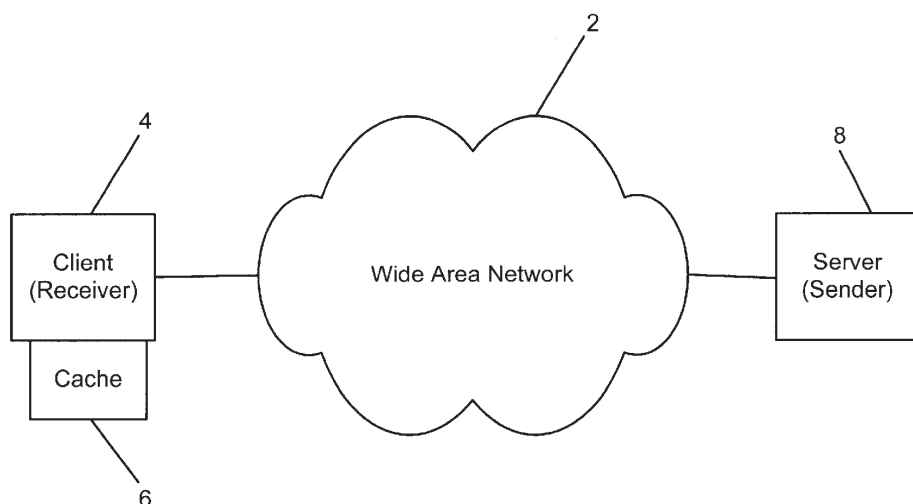

FIG. 1 (PRIOR ART)

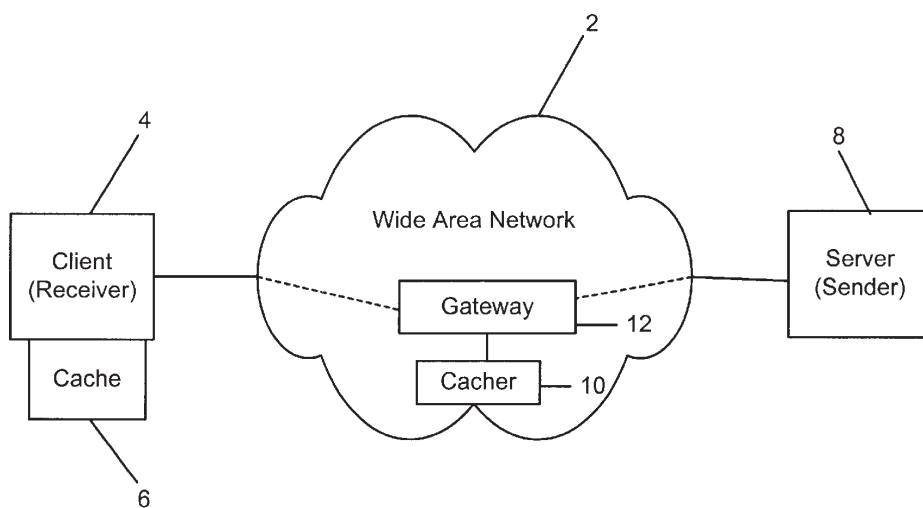

FIG. 2 (PRIOR ART)

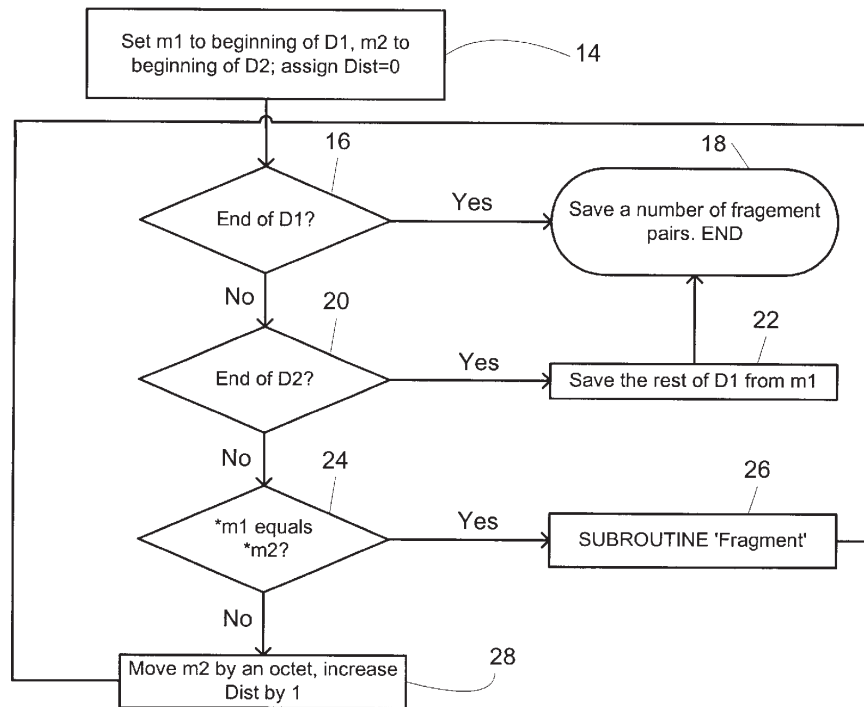
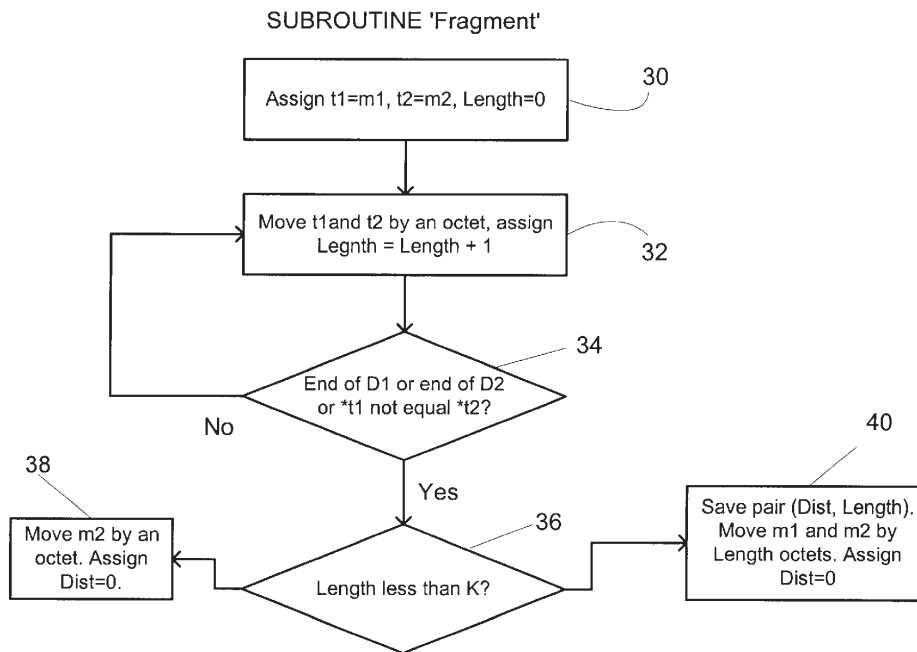
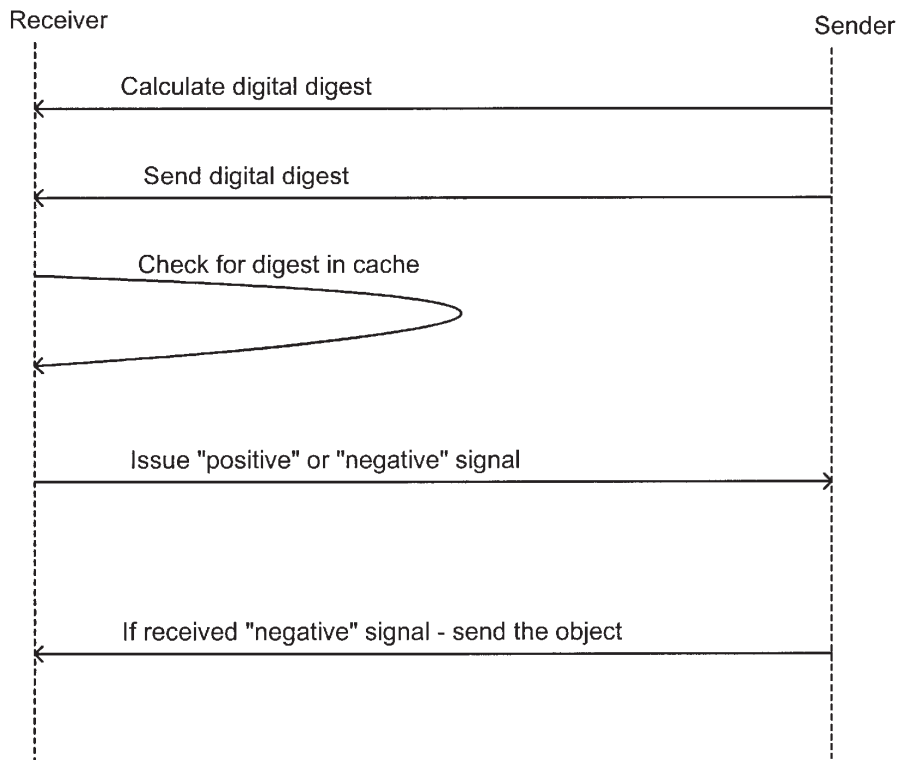
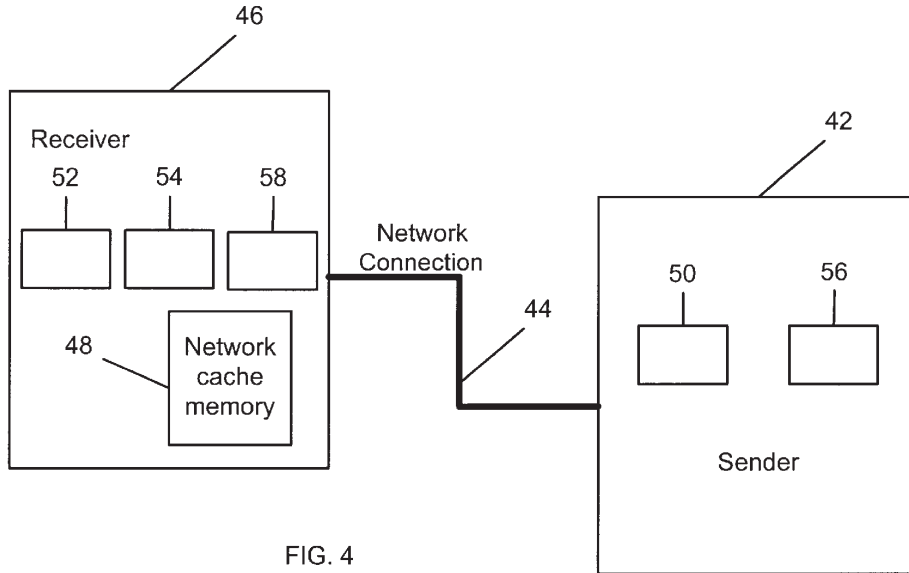
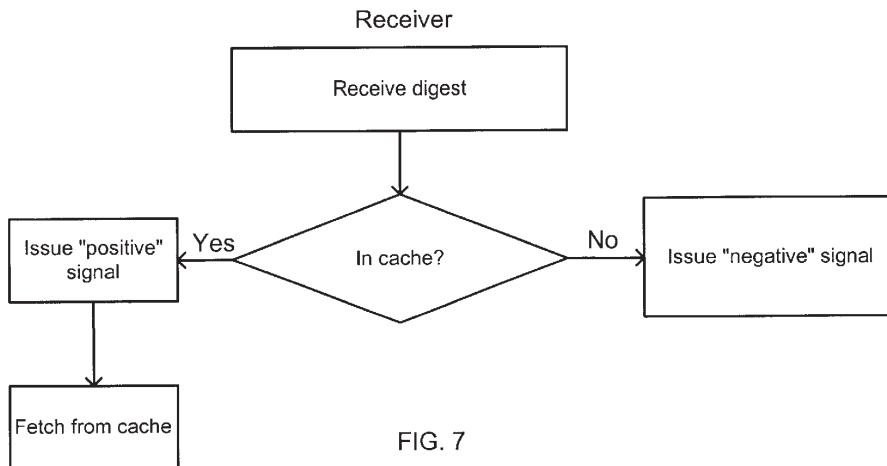
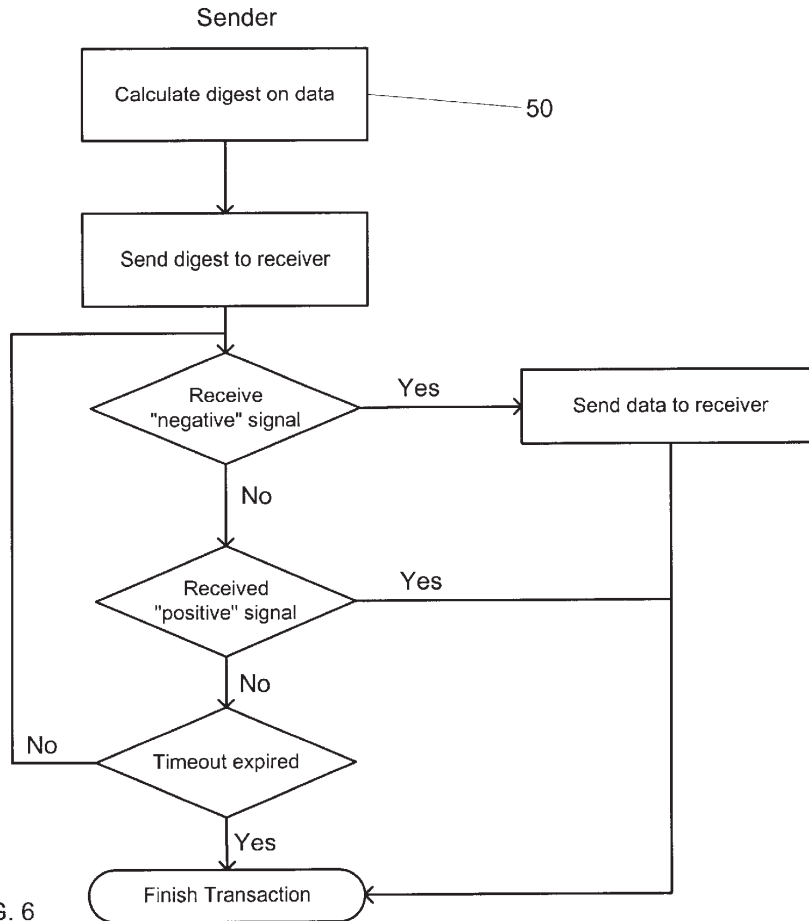

FIG. 3







Explore Litigation Insights

Docket Alarm provides insights to develop a more informed litigation strategy and the peace of mind of knowing you're on top of things.

Real-Time Litigation Alerts



Keep your litigation team up-to-date with **real-time alerts** and advanced team management tools built for the enterprise, all while greatly reducing PACER spend.

Our comprehensive service means we can handle Federal, State, and Administrative courts across the country.

Advanced Docket Research



With over 230 million records, Docket Alarm's cloud-native docket research platform finds what other services can't. Coverage includes Federal, State, plus PTAB, TTAB, ITC and NLRB decisions, all in one place.

Identify arguments that have been successful in the past with full text, pinpoint searching. Link to case law cited within any court document via Fastcase.

Analytics At Your Fingertips



Learn what happened the last time a particular judge, opposing counsel or company faced cases similar to yours.

Advanced out-of-the-box PTAB and TTAB analytics are always at your fingertips.

API

Docket Alarm offers a powerful API (application programming interface) to developers that want to integrate case filings into their apps.

LAW FIRMS

Build custom dashboards for your attorneys and clients with live data direct from the court.

Automate many repetitive legal tasks like conflict checks, document management, and marketing.

FINANCIAL INSTITUTIONS

Litigation and bankruptcy checks for companies and debtors.

E-DISCOVERY AND LEGAL VENDORS

Sync your system to PACER to automate legal marketing.