

UNITED STATES PATENT AND TRADEMARK OFFICE

BEFORE THE PATENT TRIAL AND APPEAL BOARD

**SONY CORPORATION OF AMERICA; AXIS COMMUNICATIONS
AB; and AXIS COMMUNICATIONS INC.**

Petitioners

v.

NETWORK-1 SECURITY SOLUTIONS, INC.

Patent Owner

Case IPR2013-00092

Patent 6,218,930

Before JAMESON LEE, JONI Y. CHANG, and JUSTIN T. ARBES,
Administrative Patent Judges.

ARBES, *Administrative Patent Judge.*

DECISION

Institution of *Inter Partes* Review

37 C.F.R. § 42.108

Sony Corporation of America, Axis Communications AB, and Axis Communications Inc. (“Petitioners”) filed a Petition (“Pet.”) to institute an *inter partes* review of claims 6, 8, and 9 of Patent 6,218,930 (the “’930 patent”) pursuant to 35 U.S.C. § 311 *et seq.* Patent Owner Network-1 Security Solutions, Inc. filed a preliminary response (“Prelim. Resp.”) to the Petition. We have jurisdiction under 35 U.S.C. § 314. For the reasons that follow, the Board has determined not to institute an *inter partes* review.

I. BACKGROUND

The standard for instituting an *inter partes* review is set forth in 35 U.S.C. § 314(a):

THRESHOLD – The Director may not authorize an *inter partes* review to be instituted unless the Director determines that the information presented in the petition filed under section 311 and any response filed under section 313 shows that there is a reasonable likelihood that the petitioner would prevail with respect to at least 1 of the claims challenged in the petition.

Petitioners challenge claims 6, 8, and 9 of the ’930 patent as anticipated under 35 U.S.C. §§ 102(a), (b), and (e), and as obvious under 35 U.S.C. § 103(a). Pet. 8. We deny the Petition as discussed below.

A. The ’930 Patent (Ex. 1001)

The ’930 patent, entitled “Apparatus and Method for Remotely Powering Access Equipment Over a 10/100 Switched Ethernet Network,” issued on April 17, 2001 based on Application 09/520,350, filed March 7, 2000, which claims priority to Provisional Application 60/123,688, filed Mar. 10, 1999.

The '930 patent relates to “the powering of 10/100 Ethernet compatible equipment,” specifically “automatically determining if remote equipment is capable of remote power feed and if it is determined that the remote equipment is able to accept power remotely then to provide power in a reliable non-intrusive way.” Col. 1, ll. 13-19. The patent describes how it was generally known in the prior art to power telecommunications equipment, such as telephones, remotely, but doing so had not “migrated to data communications equipment” due to various problems, such as the high power levels required by data communications equipment. Col. 1, ll. 22-32. The patent describes a need in the art to power data communications equipment remotely and to “reliably determin[e] if a remote piece of equipment is capable of accepting remote power.” Col. 1, ll. 42-44.

Figure 3 of the patent is reproduced below:

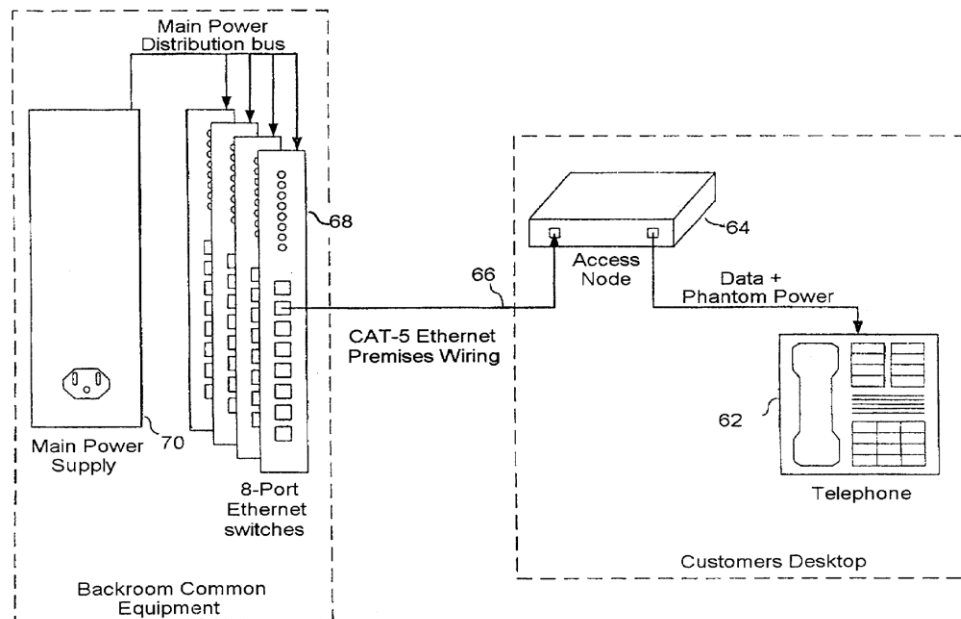

Fig. 3

Figure 3 depicts a remote telephone 62 capable of receiving and transmitting both voice and data. Col. 3, ll. 60-66. Telephone 62 is connected to access node 64 at the customer’s premises, and access node 64 is connected to one

of the ports of Ethernet switch 68 via wiring 66 comprising “a Category 5 Ethernet 100BaseX cable of 4 sets of unshielded twisted pairs.” *Id.* Ethernet switch 68 comprises an automatic remote power detector 22 (shown in Fig. 1) and remote power supply 34 (shown in Fig. 2). Col. 4, ll. 1-4.

The preferred embodiment described in the '930 patent operates as follows. A remote access device, such as the telephone shown in Figure 3, is normally powered by “an ac transformer adapter plugged in to the local 110 volt supply,” but may or may not be capable of being powered remotely. Col. 2, ll. 40-44. The system detects whether the access device is capable of being powered remotely by “delivering a low level current (approx. 20 ma)” over existing twisted pairs of an Ethernet cable used for data signaling and “measuring a voltage drop in the return path.” Col. 2, l. 66-col. 3, l. 2; col. 3, ll. 44-48. If there is no voltage drop or a fixed voltage level is detected, the device is not capable of accepting remote power. Col. 3, ll. 2-11. If a varying or “sawtooth” voltage level occurs (caused by the access device repeatedly beginning to start up but being “unable to sustain the start up” due to the low current level), the device is capable of accepting remote power. Col. 3, ll. 12-22. The system then increases the power being supplied remotely to the access device. *Id.* Once the access device is operating under remote power, the system looks for removal of the access device and decreases the power being supplied when the device is no longer connected. Col. 3, ll. 49-58.

B. The Challenged Claims

Claims 6, 8, and 9 of the '930 patent recite:

6. Method for remotely powering access equipment in a data network, comprising,

providing a data node adapted for data switching, an access device adapted for data transmission, at least one data signaling pair connected between the data node and the access device and arranged to transmit data therebetween, a main power source connected to supply power to the data node, and a secondary power source arranged to supply power from the data node via said data signaling pair to the access device,

delivering a low level current from said main power source to the access device over said data signaling pair,

sensing a voltage level on the data signaling pair in response to the low level current, and

controlling power supplied by said secondary power source to said access device in response to a preselected condition of said voltage level.

8. Method according to claim 6, including the step of polling the access device to identify it and confirm that it is capable of accepting remote power.

9. Method according to claim 6, including the step of continuing to sense voltage level and to decrease power from the secondary power source if voltage level drops on the data signaling pair, indicating removal of the access device.

C. The Prior Art

Petitioners rely on the following prior art:

1. Patent 5,991,885, filed June 11, 1997, issued Nov. 23, 1999 (“Chang”) (Ex. 1003);

2. Patent 5,345,592, issued Sept. 6, 1994 (“Woodmas”) (Ex. 1005);

Explore Litigation Insights

Docket Alarm provides insights to develop a more informed litigation strategy and the peace of mind of knowing you're on top of things.

Real-Time Litigation Alerts



Keep your litigation team up-to-date with **real-time alerts** and advanced team management tools built for the enterprise, all while greatly reducing PACER spend.

Our comprehensive service means we can handle Federal, State, and Administrative courts across the country.

Advanced Docket Research



With over 230 million records, Docket Alarm's cloud-native docket research platform finds what other services can't. Coverage includes Federal, State, plus PTAB, TTAB, ITC and NLRB decisions, all in one place.

Identify arguments that have been successful in the past with full text, pinpoint searching. Link to case law cited within any court document via Fastcase.

Analytics At Your Fingertips



Learn what happened the last time a particular judge, opposing counsel or company faced cases similar to yours.

Advanced out-of-the-box PTAB and TTAB analytics are always at your fingertips.

API

Docket Alarm offers a powerful API (application programming interface) to developers that want to integrate case filings into their apps.

LAW FIRMS

Build custom dashboards for your attorneys and clients with live data direct from the court.

Automate many repetitive legal tasks like conflict checks, document management, and marketing.

FINANCIAL INSTITUTIONS

Litigation and bankruptcy checks for companies and debtors.

E-DISCOVERY AND LEGAL VENDORS

Sync your system to PACER to automate legal marketing.