



US006415280B1

(12) **United States Patent**
Farber et al.

(10) **Patent No.:** **US 6,415,280 B1**
(45) **Date of Patent:** ***Jul. 2, 2002**

(54) **IDENTIFYING AND REQUESTING DATA IN NETWORK USING IDENTIFIERS WHICH ARE BASED ON CONTENTS OF DATA**

(75) Inventors: **David A. Farber**, Ojai, CA (US);
Ronald D. Lachman, Northbrook, IL (US)

(73) Assignees: **Kinetech, Inc.**, Northbrook, IL (US);
Digital Island, Inc., San Francisco, CA (US)

(*) Notice: Subject to any disclaimer, the term of this patent is extended or adjusted under 35 U.S.C. 154(b) by 0 days.

This patent is subject to a terminal disclaimer.

(21) Appl. No.: **09/283,160**

(22) Filed: **Apr. 1, 1999**

Related U.S. Application Data

(62) Division of application No. 08/960,079, filed on Oct. 24, 1997, now Pat. No. 5,978,791, which is a continuation of application No. 08/425,160, filed on Apr. 11, 1995, now abandoned.

(51) **Int. Cl.**⁷ **G06F 17/30**

(52) **U.S. Cl.** **707/2; 707/3; 707/10; 707/101; 709/203; 709/219; 709/229**

(58) **Field of Search** **707/3, 10, 101, 707/2; 709/203, 219, 229**

(56) **References Cited**

U.S. PATENT DOCUMENTS

4,922,417 A	5/1990	Churm et al.	707/1
5,202,982 A *	4/1993	Gramlich et al.	707/2
5,287,499 A	2/1994	Nemes	707/2
5,341,477 A	8/1994	Pitkin et al.	709/226
5,452,447 A *	9/1995	Nelson et al.	707/205
5,542,087 A	7/1996	Neimat et al.	707/10

5,638,443 A	6/1997	Stefik et al.	705/54
5,640,564 A *	6/1997	Hamilton et al.	709/303
5,802,291 A	9/1998	Balick et al.	709/202
5,809,494 A *	9/1998	Nguyen	707/1
5,907,704 A	5/1999	Gudmundson et al.	
6,006,018 A *	12/1999	Burnett et al.	395/200.49
6,134,603 A *	10/2000	Jones et al.	709/330

OTHER PUBLICATIONS

Gwertzman, James, et al. "The Case for Geographical Push-Caching." Technical Report HU TR 34-94 (excerpt), Harvard University, DAS, Cambridge, MA 02138, 1994, 2 pgs.
Grigni, Michelangelo, et al. "Tight Bounds on Minimum Broadcasts Networks." SIAM Journal of Discrete Mathematics, vol. 4, No. 2, May 1991, pp. 207-222.

(List continued on next page.)

Primary Examiner—Jean R. Homere

(74) *Attorney, Agent, or Firm*—Pillsbury Winthrop LLP Intellectual Property

(57) **ABSTRACT**

In a system in which a set of data items are distributed across a network of servers, at least some of the data items being cached versions of data items from a source server, a content delivery method includes determining a data identifier for a particular data item, the data identifier being determined using a given function of the data comprising the particular data item; and responsive to a request for the particular data item, the request including at least the data identifier of the particular data item, providing the particular data item from a given one of the servers of the network of servers. The request for the particular data item may be resolved based on a measure of availability of at least one of the servers, where the measure of availability may be a measurement of bandwidth to the server; a measurement of a cost of a connection to the server, and/or a measurement of a reliability of a connection to the server. The function used to determine the identifier may be a message digest function or a hash function.

55 Claims, 31 Drawing Sheets

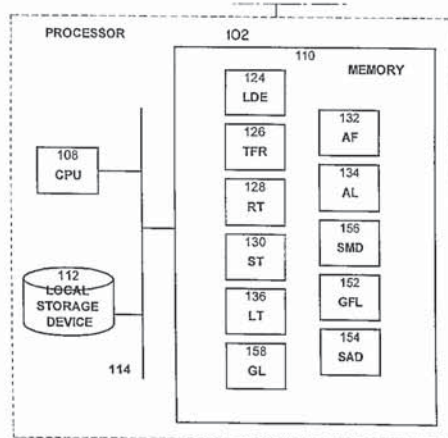
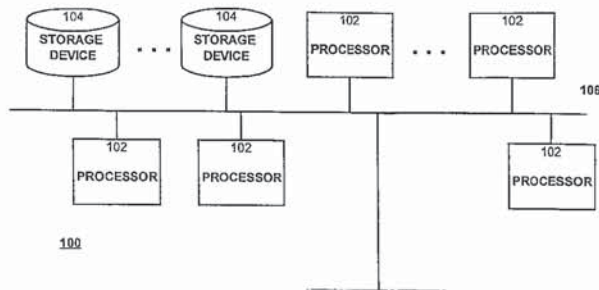

OTHER PUBLICATIONS

- Devine, Robert. "Design and Implementation of DDH: A Distributed Dynamic Hashing Algorithm." In Proceedings of 4th International Conference on Foundations of Data Organizations and Algorithms, 1993, pp. 101-114.
- Deering, Stephen, et al. "Multicast Routing in Datagram Internetworks and Extended LANs." *ACM Transactions on Computer Systems*, vol. 8, No. 2, May 1990, pp. 85-110.
- Cormen, Thomas H., et al. *Introduction to Algorithms*, The MIT Press, Cambridge, Massachusetts, 1994, pp. 219-243, 991-993.
- Naor, Moni, et al. "The Load, Capacity and Availability of Quorum Systems." In Proceedings of the 35th IEEE Symposium on Foundations of Computer Science, Nov. 1994, pp. 214-225.
- Nisan, Noam. "Pseudorandom Generators for Space-Bounded Computation." In Proceedings of the Twenty-Second Annual ACM Symposium on Theory of Computing, May 1990, pp. 204-212.
- Palmer, Mark et al. "Fido: A Cache that Learns to Fetch." In Proceedings of the 17th International Conference on Very Large Data Bases, Sep. 1991, pp. 255-264.
- Peleg, David, et al. "The Availability of Quorum Systems." *Information and Computation* 123, 1995, 210-223.
- Rabin, Michael. "Efficient Dispersal of Information for Security, Load Balancing, and Fault Tolerance." *Journal of the ACM*, vol. 36, No. 2, Apr. 1989, pp. 335-348.
- Ravi, R., "Rapid Rumor Ramification: Approximating the Minimum Broadcast Time." In Proceedings of the 35th IEEE Symposium on Foundation of Computer Science, Nov. 1994, pp. 202-213.
- Schmidt, Jeanette, et al. "Chernoff-Hoeffding Bounds for Applications with Limited Independence." In Proceedings of the 4th ACS-SIAM Symposium on Discrete Algorithms, 1993, pp. 331-340.
- Tarjan, Robert Endre, et al. "Storing a Sparse Table." *Communications of the ACM*, vol. 22, No. 11, Nov. 1979, pp. 606-611.
- Wegman, Mark, et al. "New Hash Functions and Their Use in Authentication and Set Equality." *Journal of Computer and System Sciences* vol. 22, Jun. 1981, pp. 265-279.
- Vitter, Jeffrey Scott, et al. "Optimal Prefetching via Data Compression." In Proceedings of 32nd IEEE Symposium on Foundations of Computer Science, Nov. 1991, pp. 121-130.
- Fredman, Michael, et al. "Storing a Sparse Table with $O(1)$ Worst Case Access Time." *Journal of the Association for Computing Machinery*, vol. 31, No. 3, Jul. 1984, pp. 538-544.
- Yao, Andrew Chi-Chih. "Should Tables be Sorted?" *Journal of the Association for Computing Machinery*, vol. 28, No. 3, Jul. 1981, pp. 615-628.
- Floyd, Sally, et al. "A reliable Multicast Framework for Light-Weight Sessions and Application Level Framing." In Proceedings of ACM SIGCOMM '95, pp. 342-356.
- Feeley, Michael, et al. "Implementing Global Memory Management in a Workstation Cluster." In Proceedings of the 15th ACM Symposium on Operating Systems Principles, 1995, pp. 201-212.
- Carter, J. Lawrence, et al. "Universal Classes of Hash Functions." *Journal of Computer and System Sciences*, vol. 18, No. 2, Apr. 1979, pp. 143-154.
- Patent Abstracts of Japan, "Electronic Mail Multiplexing System and Communication Control Method in The System." Jun. 30, 1993, JP 051625293.
- Kim et al., "Experiences with Tripwire: Using Integrity Checkers For Intrusion Detection", Coast Labs. Dept. of Computer Sciences Purdue University, Feb. 22, 1995, pp. 1-12.
- Kim et al., "The Design and Implementation of Tripwire: A file System Integrity Checker", Coast Labs. Dept. of Computer Sciences Purdue University, Nov. 19, 1993, pp. 1-21.

* cited by examiner

FIG. 1(a)

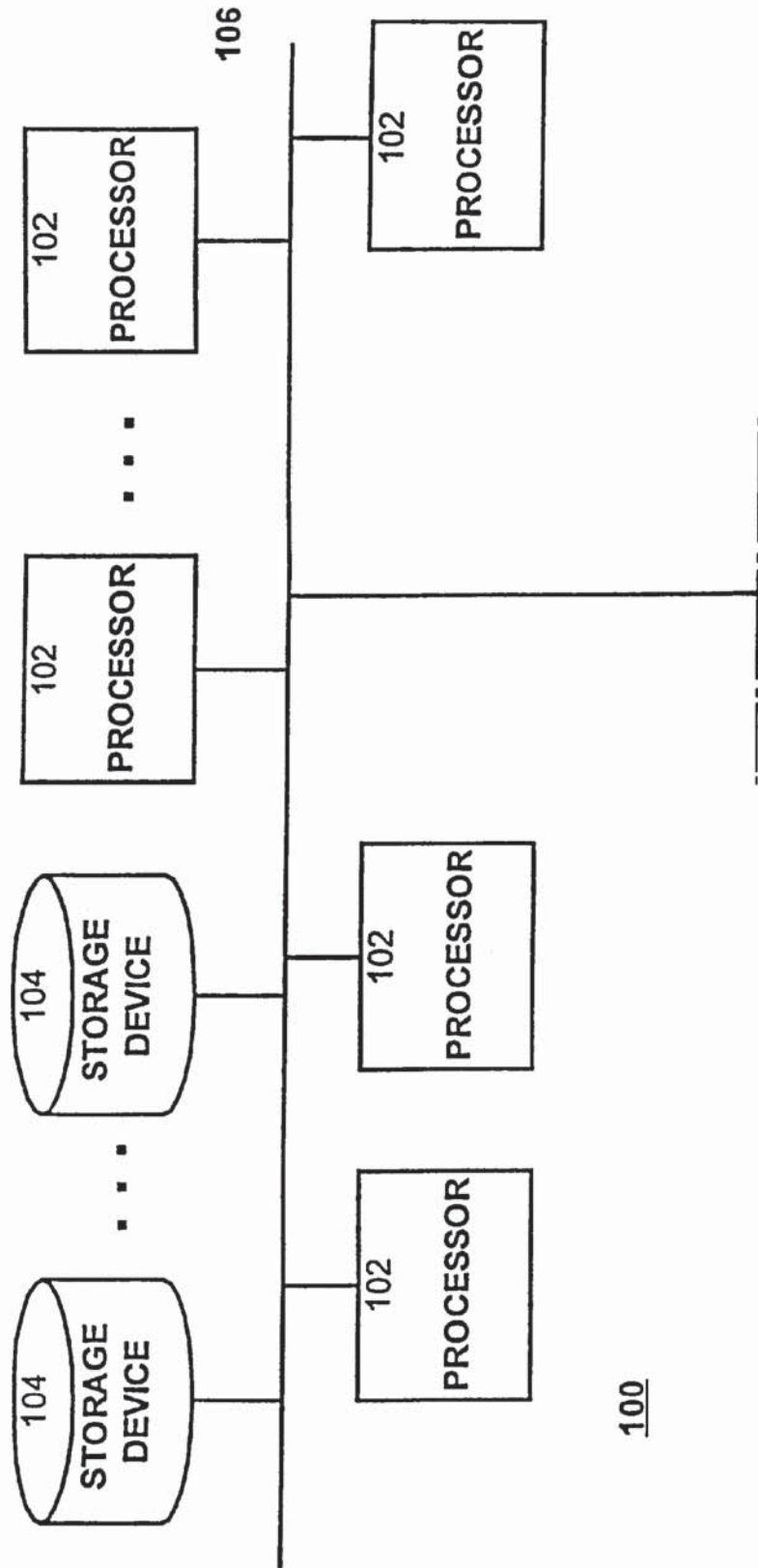

100

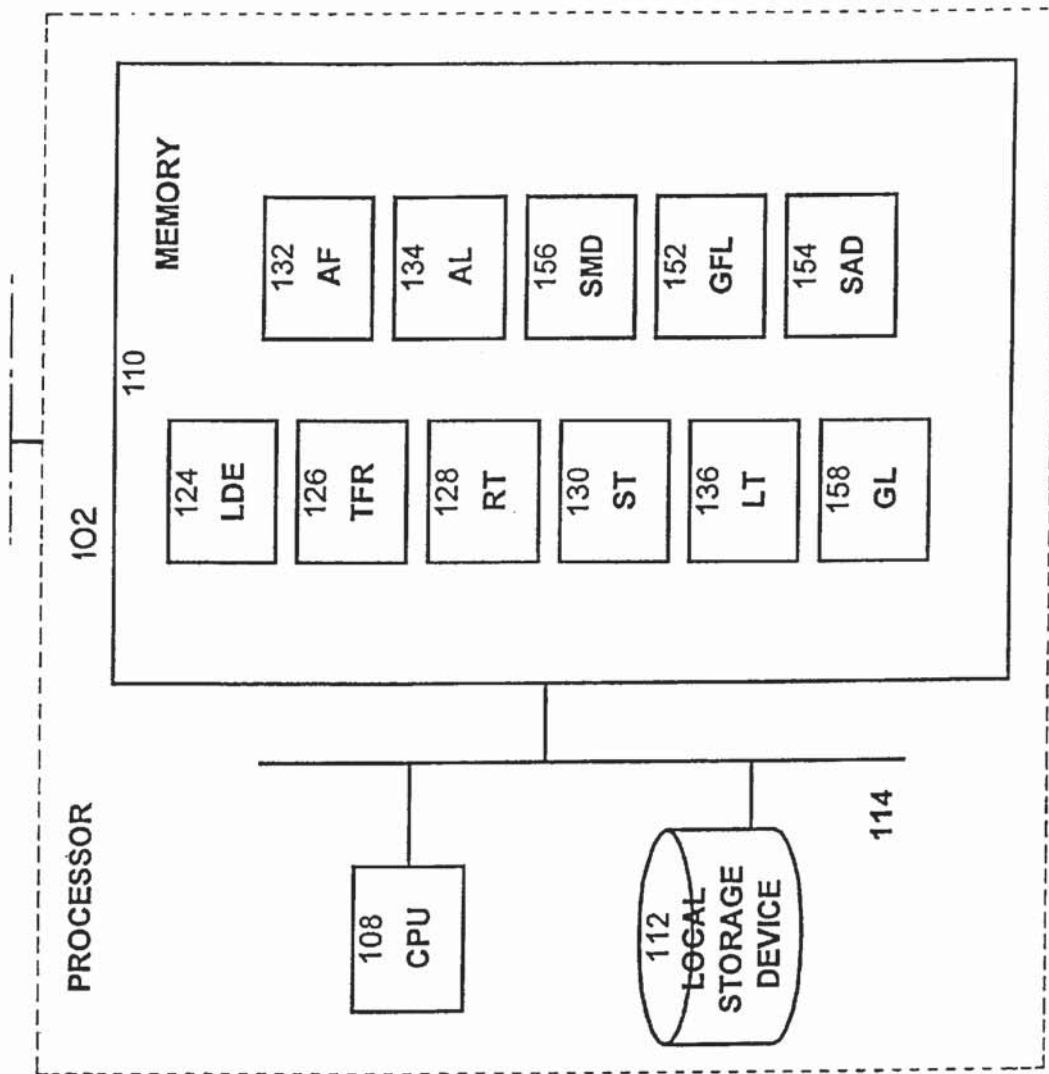

FIG. 1(b)

FIG. 2

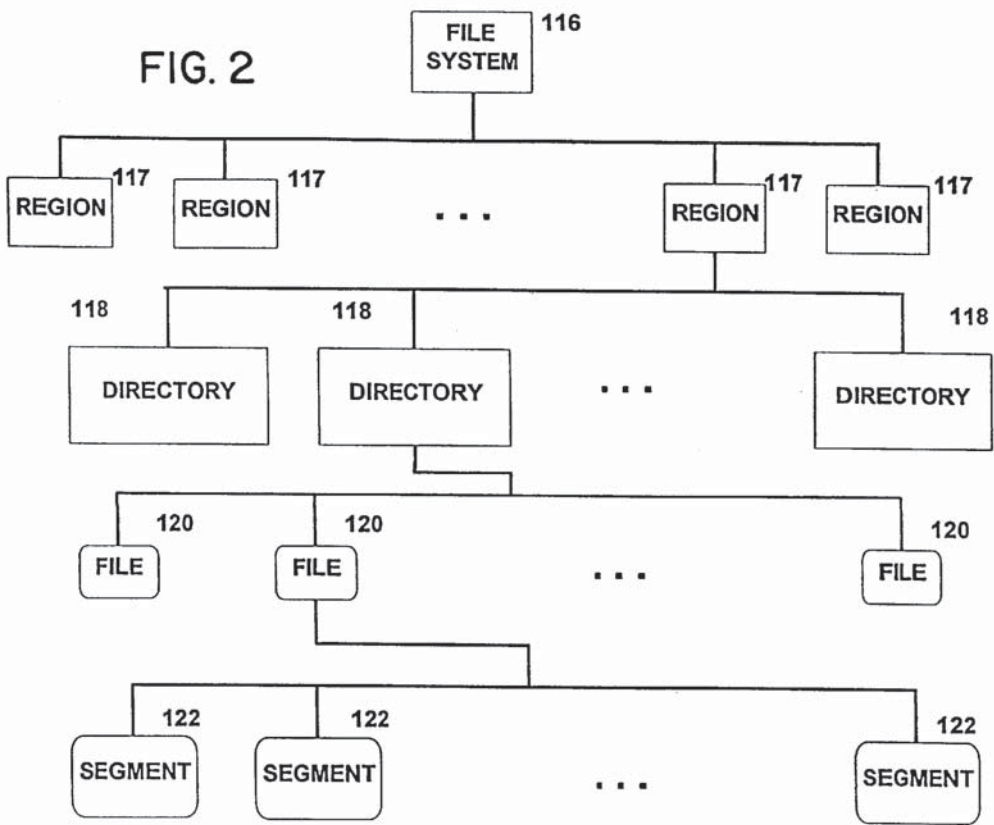

FIG. 3

138-

Region ID
Pathname
True Name
Type
File ID
Time of last access
Time of last modification
Safe flag
Lock flag
Size
Owner

FIG. 4

140

True Name
File ID
Compressed File ID
Source IDs
Dependent processors
Use count
Time of last access
Expiration
Grooming delete count

142

Region ID
Region file system
Region pathname
Region status
Mirror processor(s)
Mirror duplication count
Policy

FIG. 5

FIG. 6

	144
source ID	
source type	
source rights	
source availability	
source location	

FIG. 7

	146
Original Name	
Operation	
Type	
Processor ID	
Timestamp	
Pathname	
True Name	

FIG. 8

	148
date of entry	
type of entry	
True Name	

FIG. 9

	150
True Name	
licensee	

FIG. 10(a)

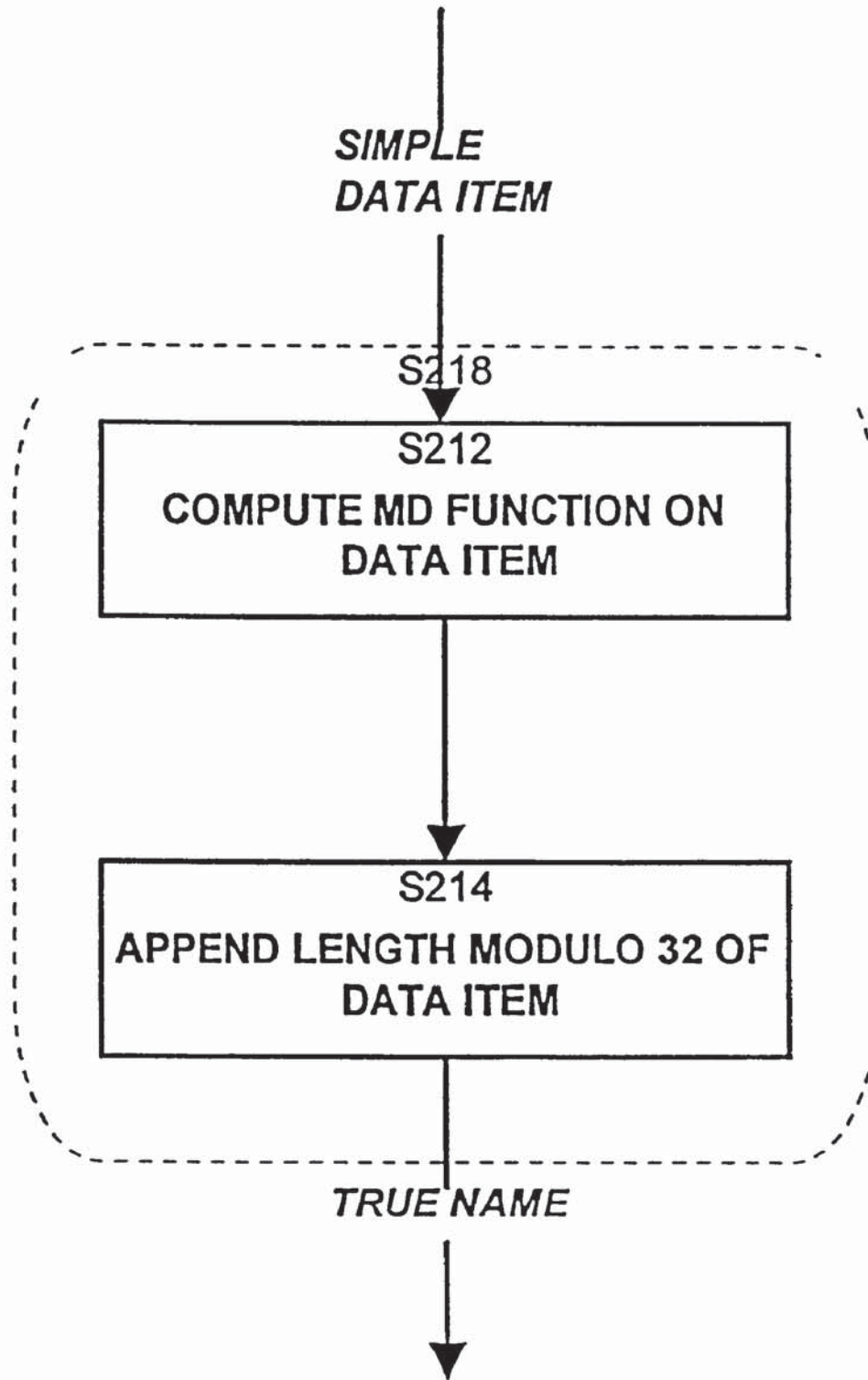

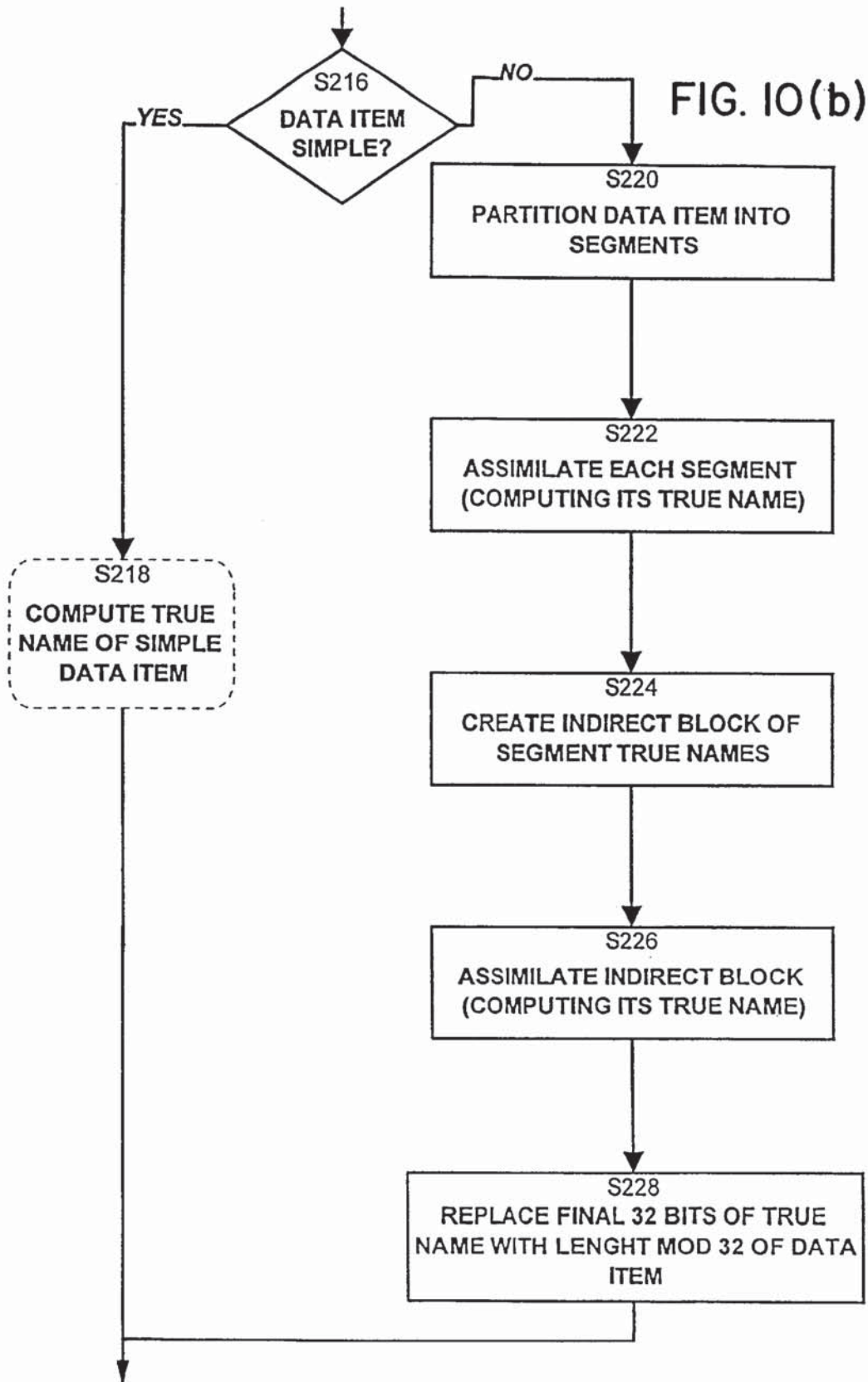

FIG. 11

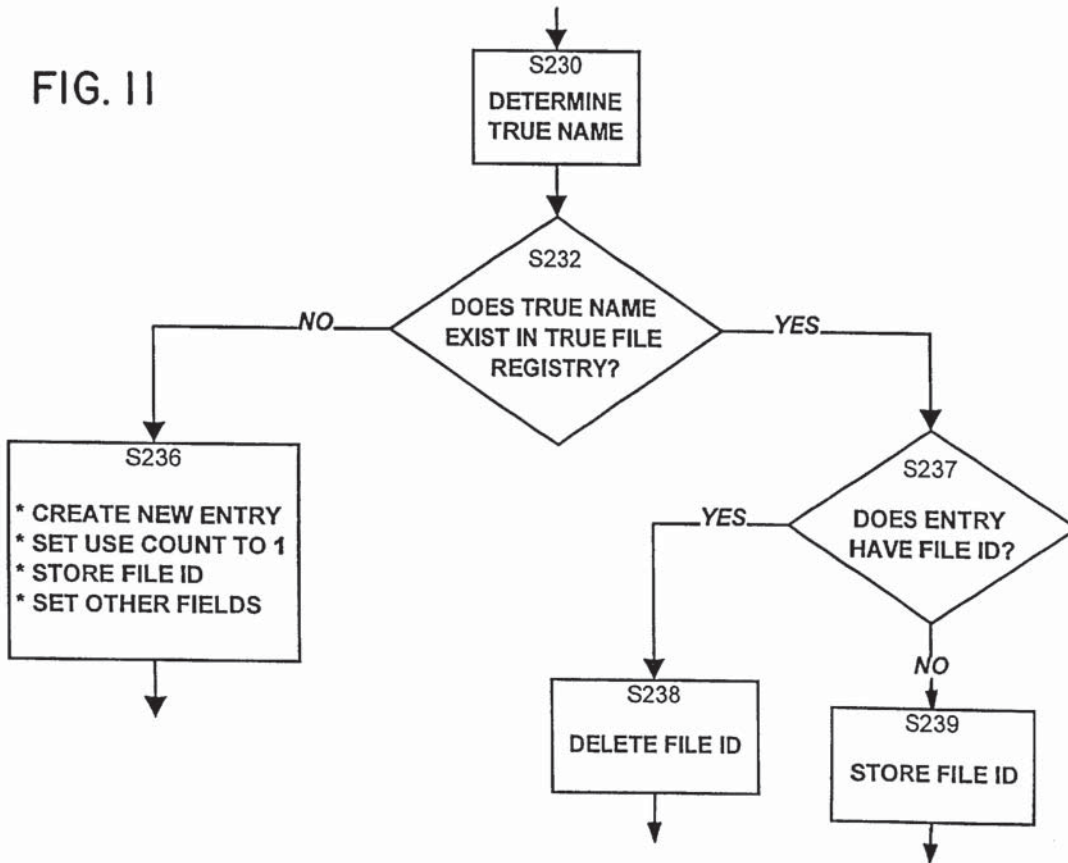

FIG. 12

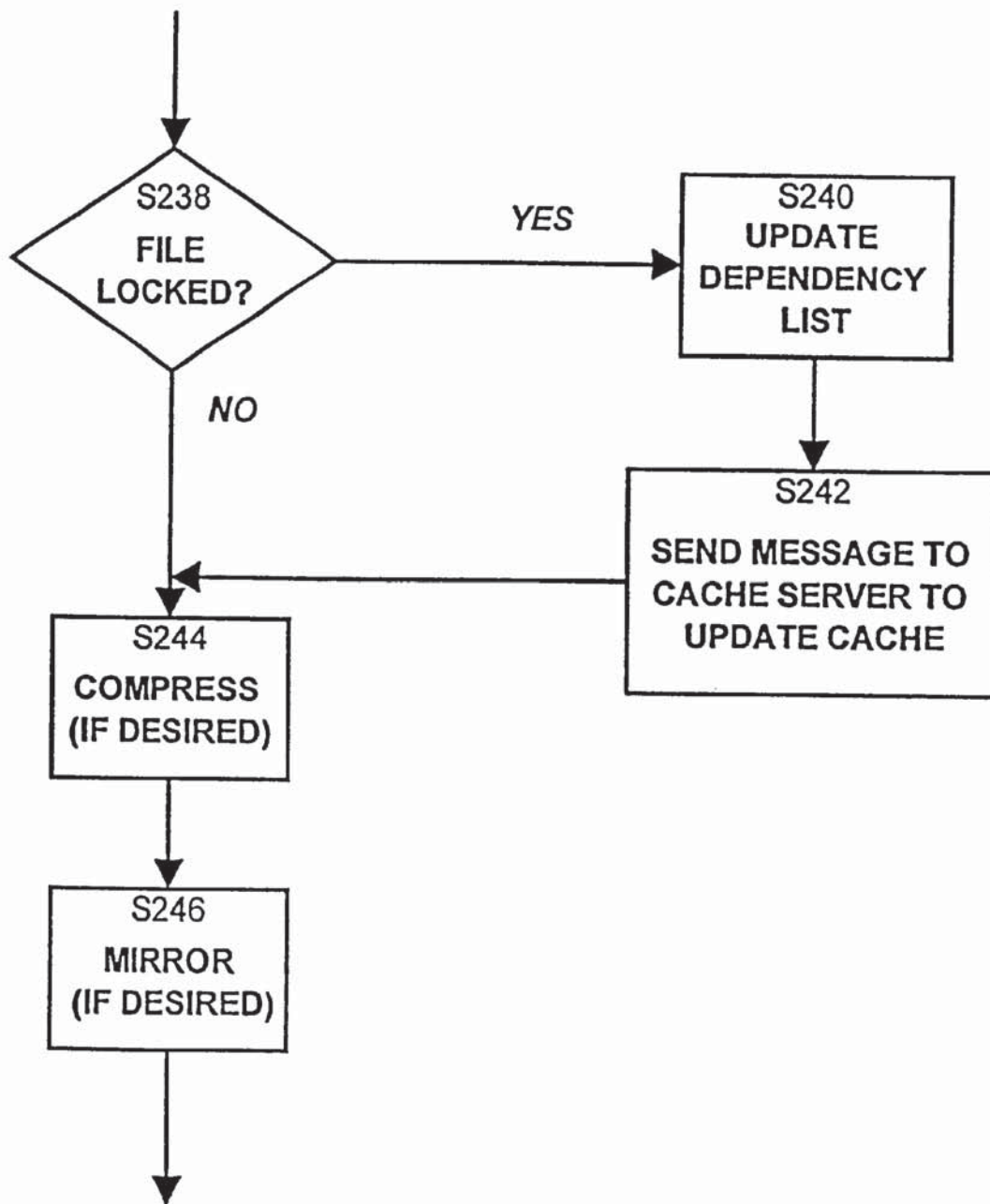
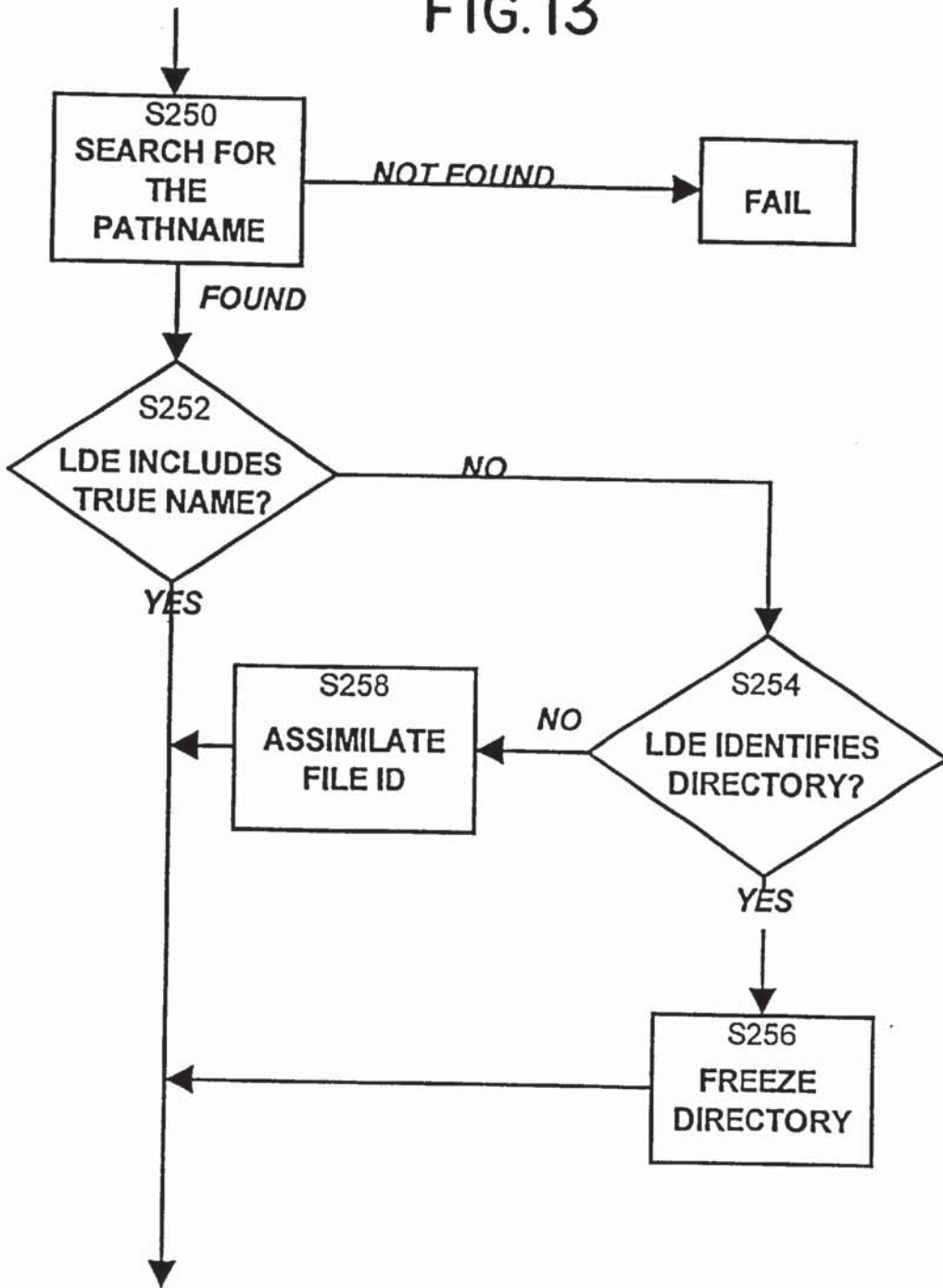

FIG. 13



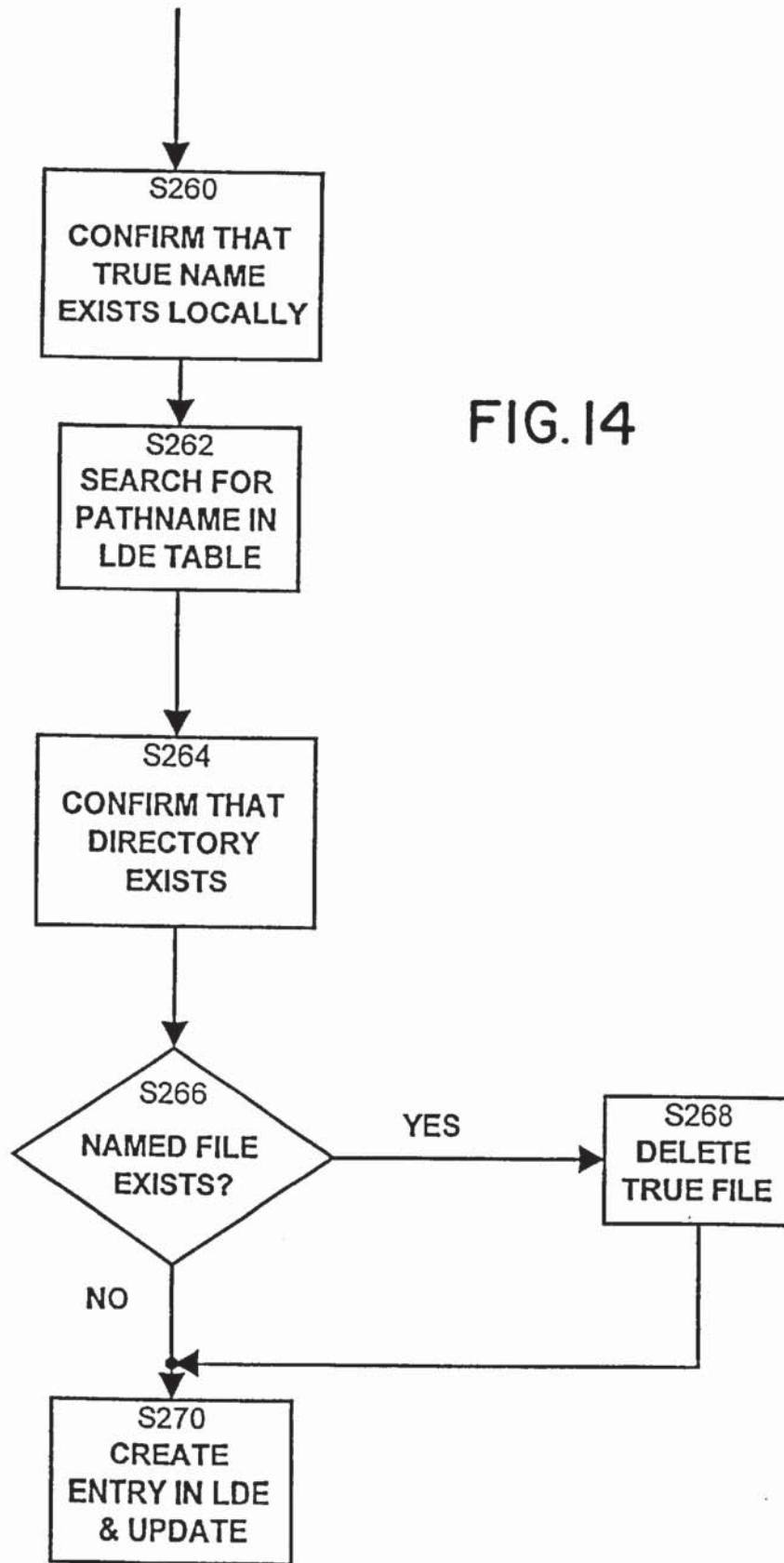

FIG. 14

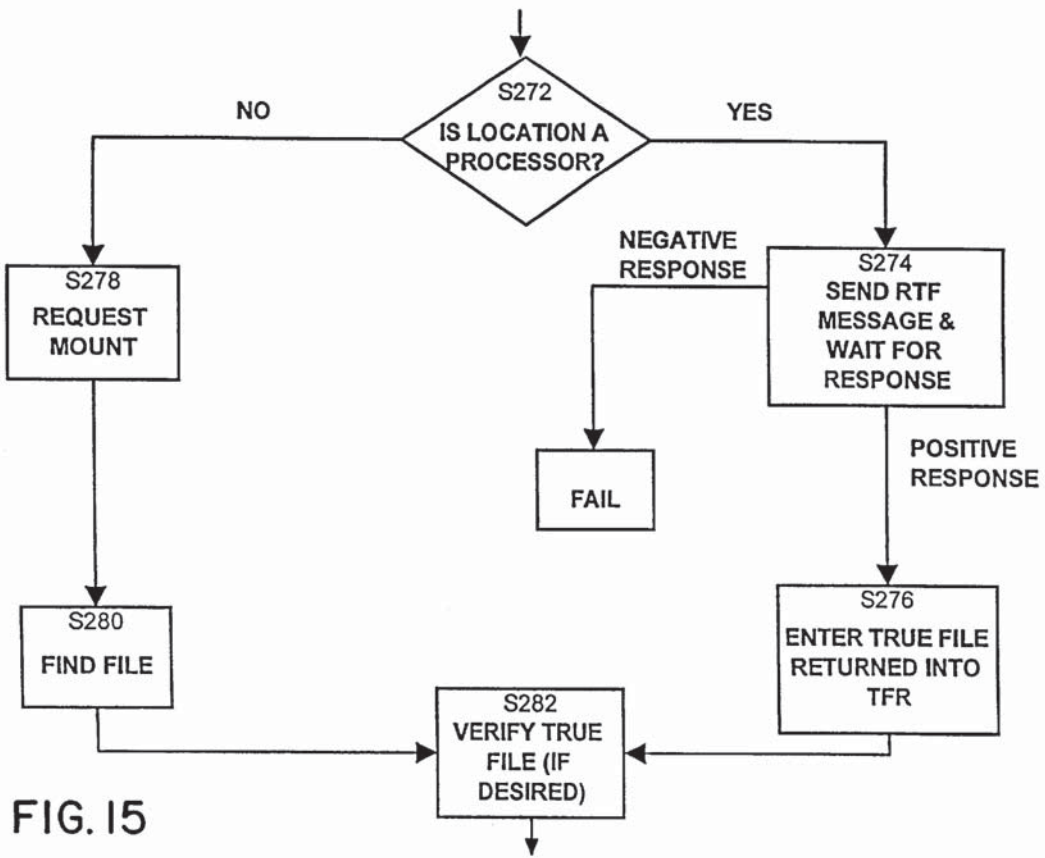

FIG. 15

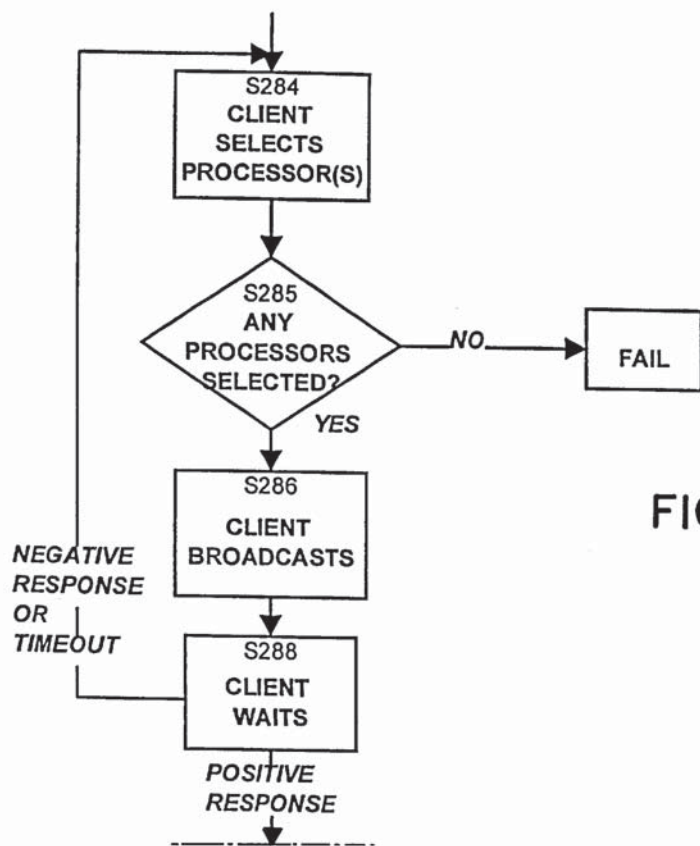

FIG. 16(a)

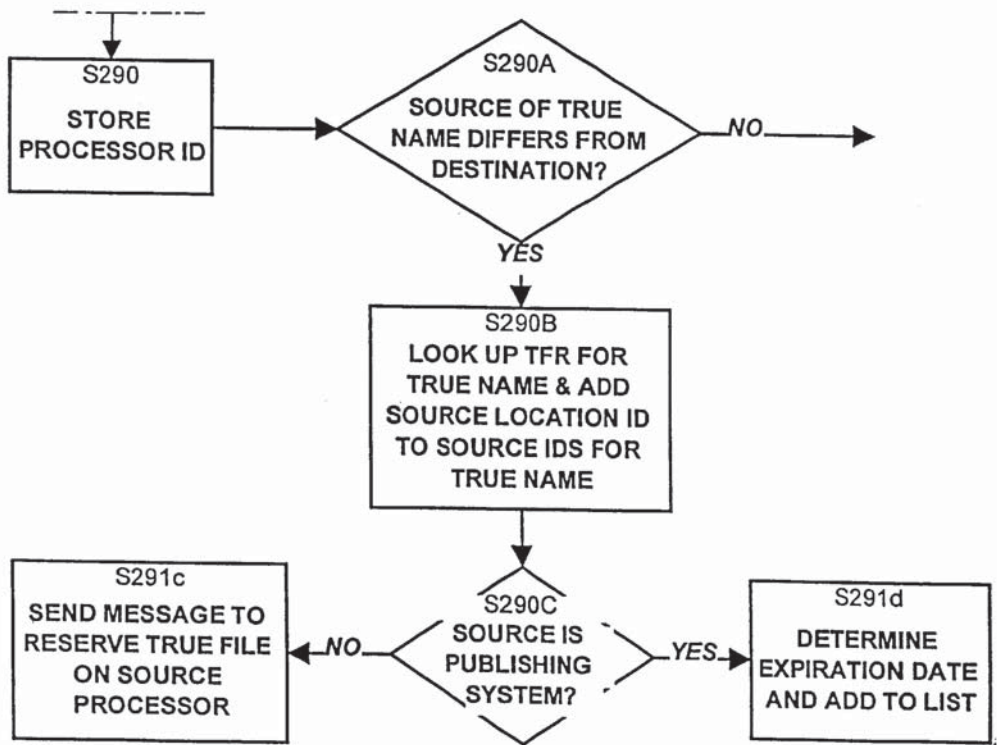

FIG. 16(b)

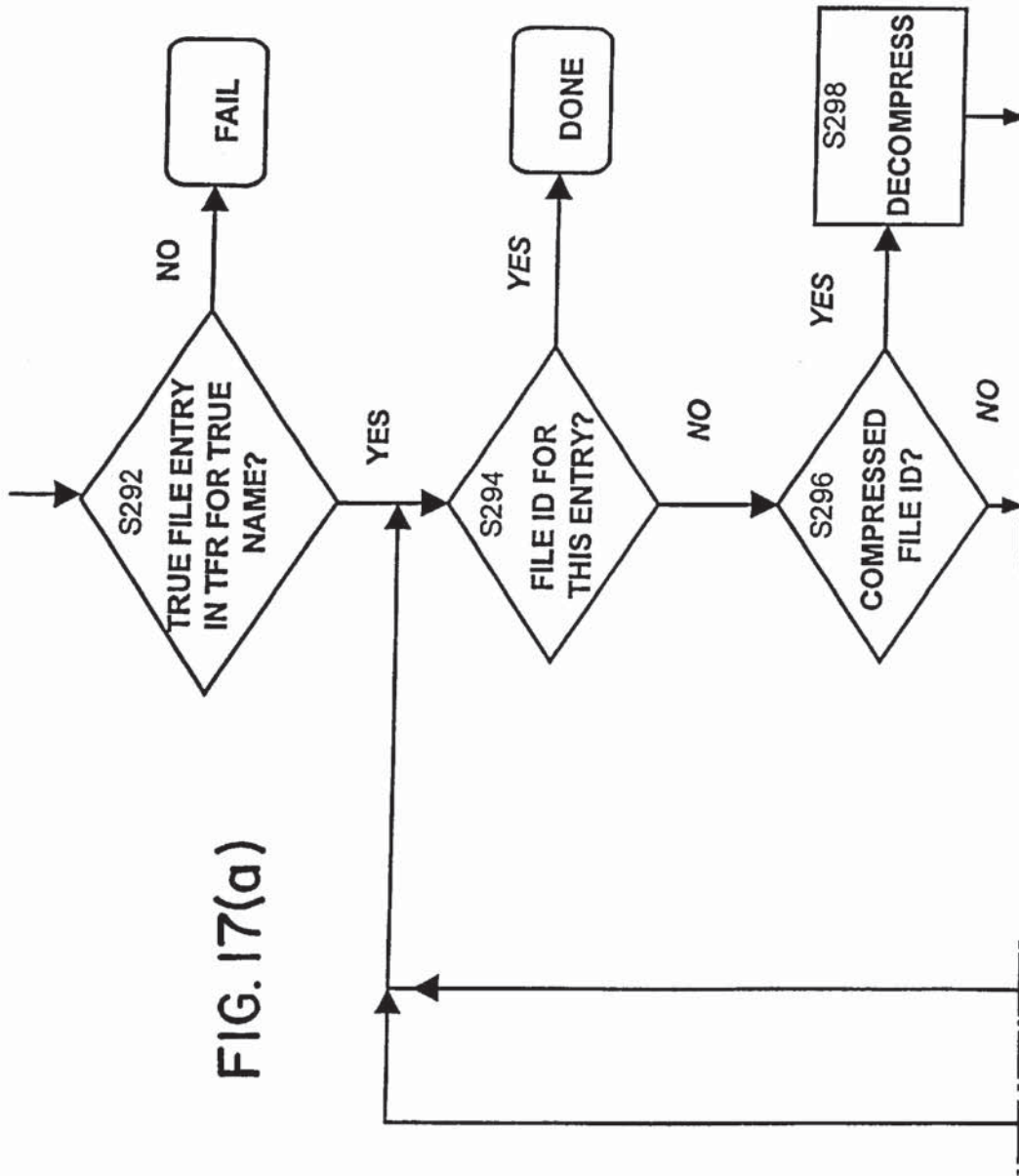

FIG. 17(a)

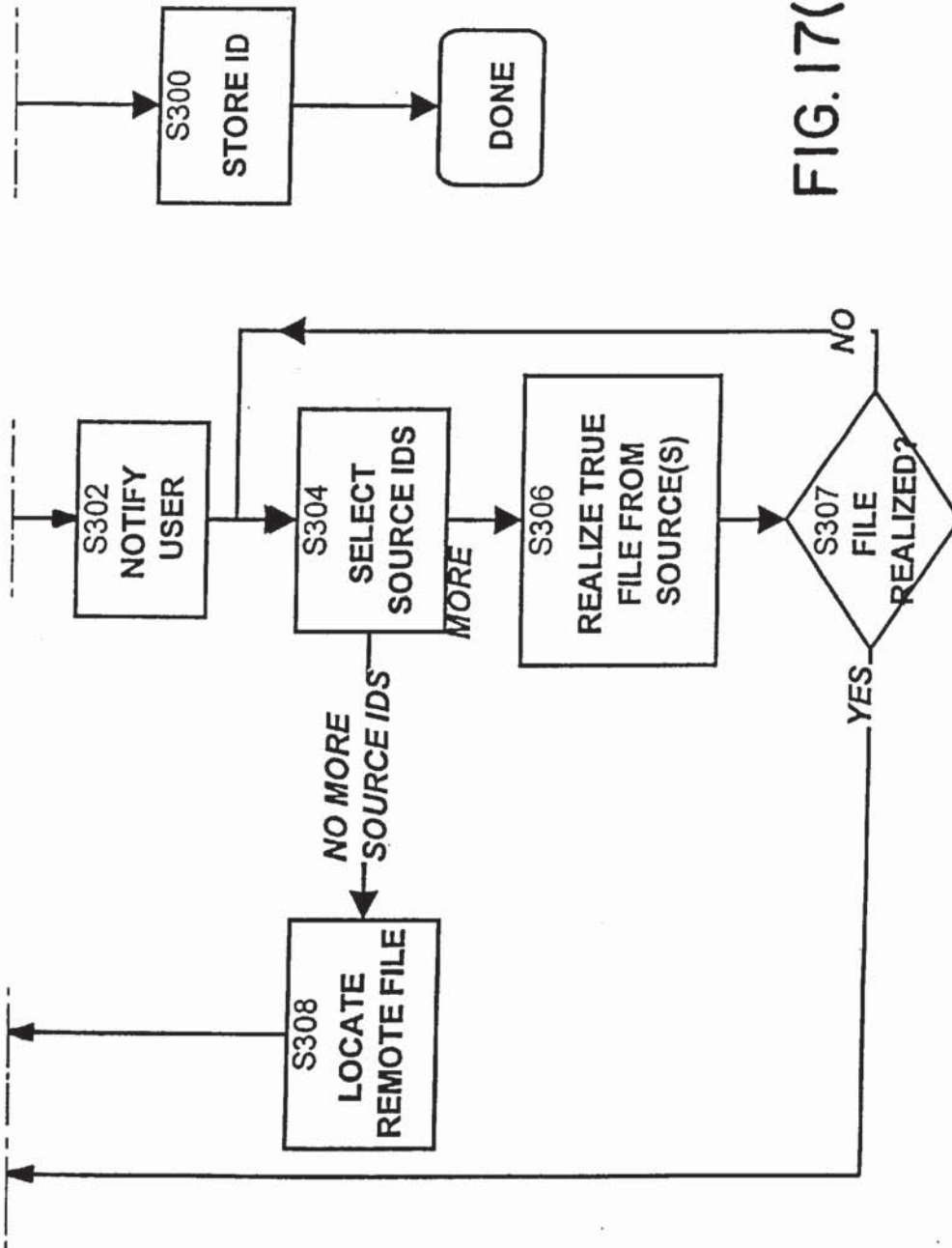
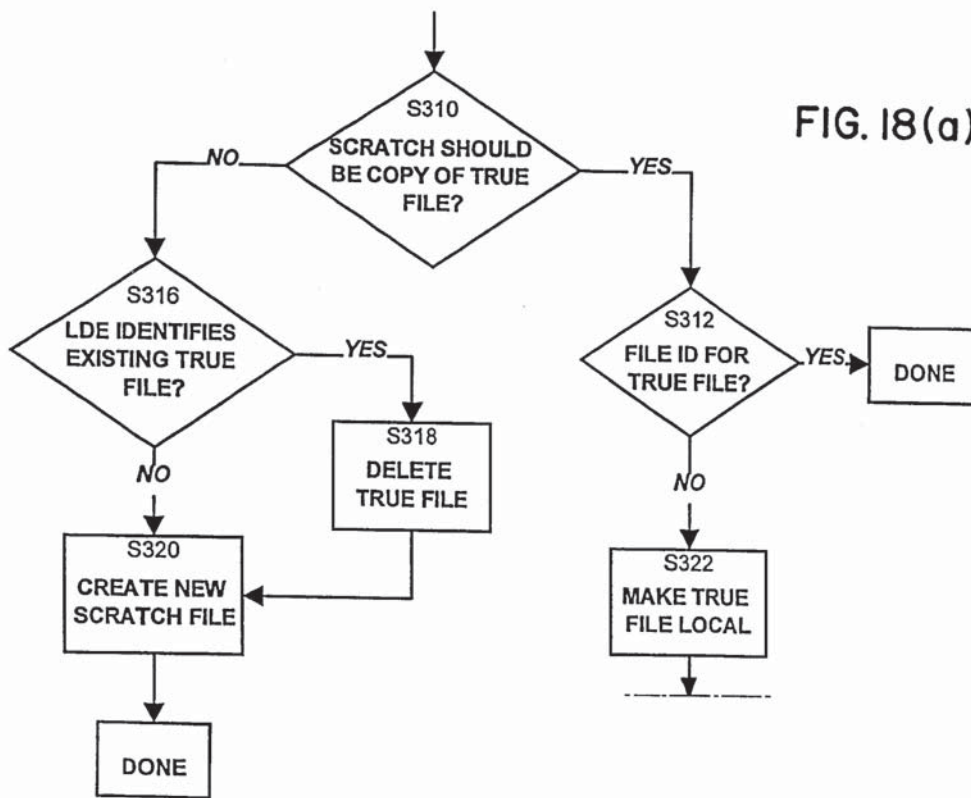

FIG. 17(b)

FIG. 18(a)



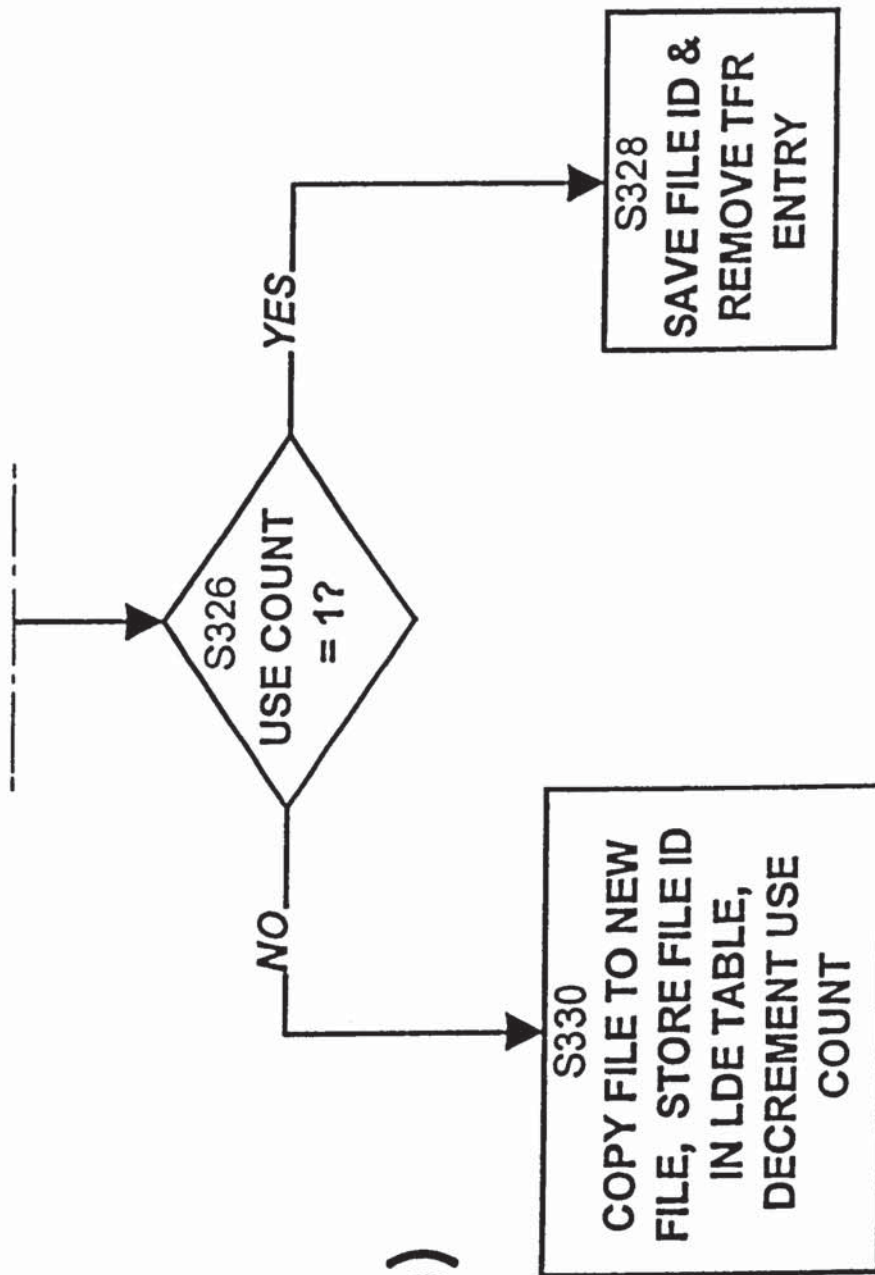
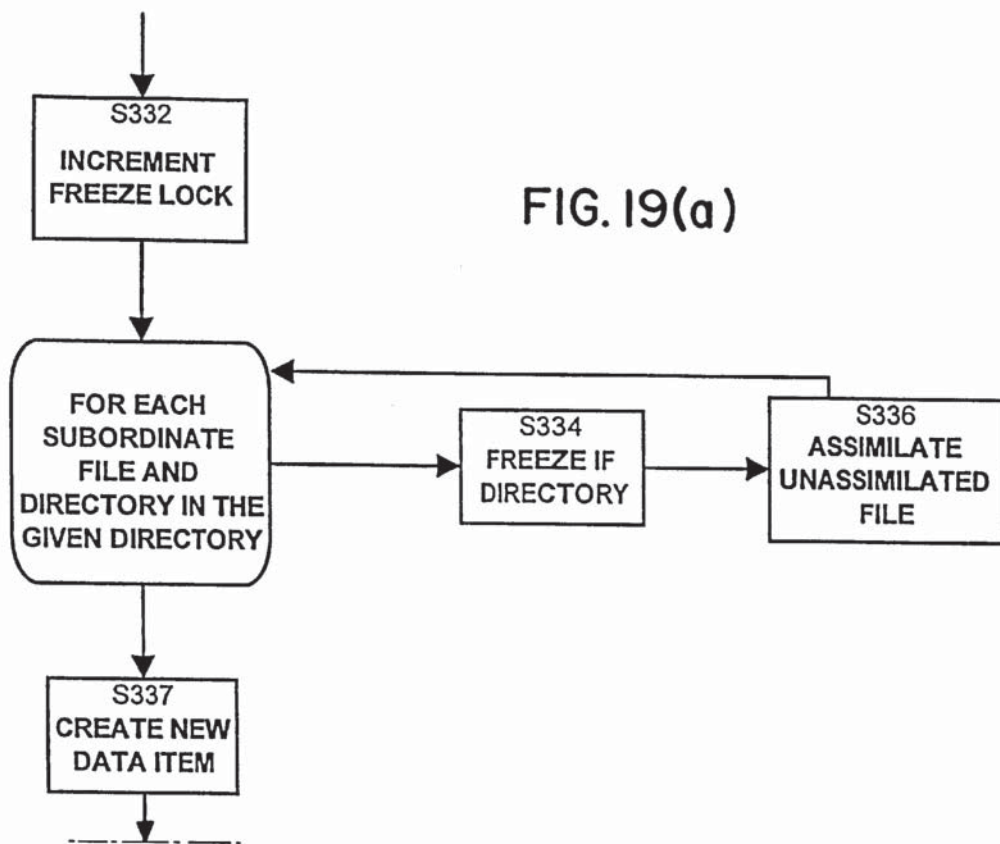

FIG. 18(b)

FIG. 19(a)



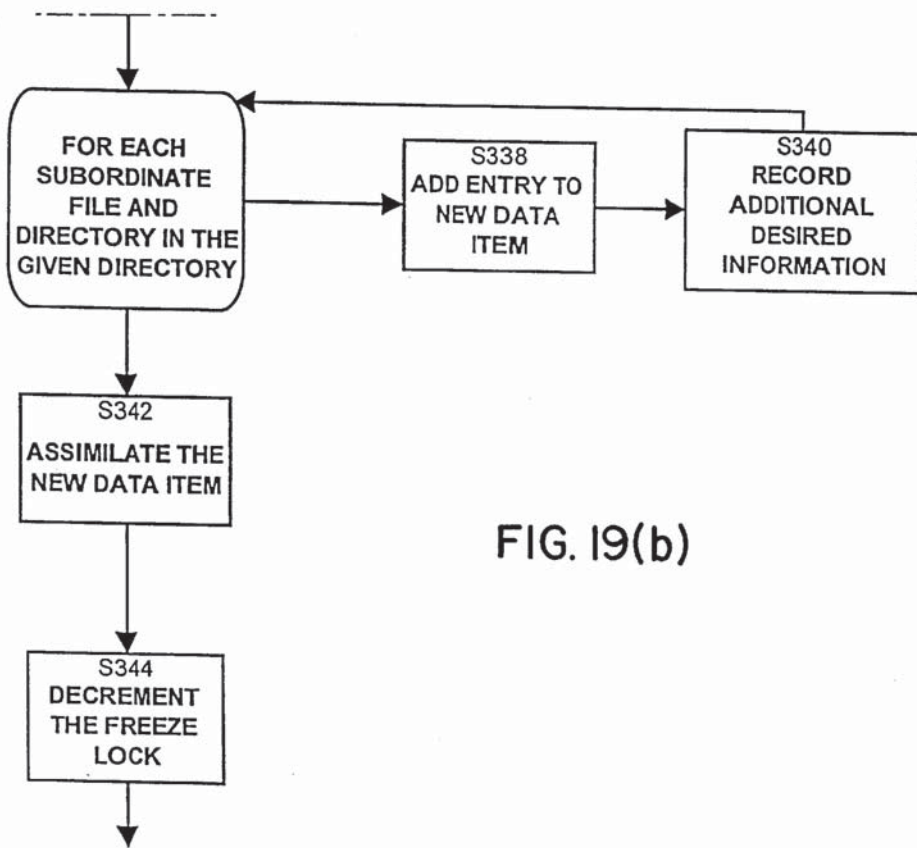

FIG. 19(b)

FIG. 20

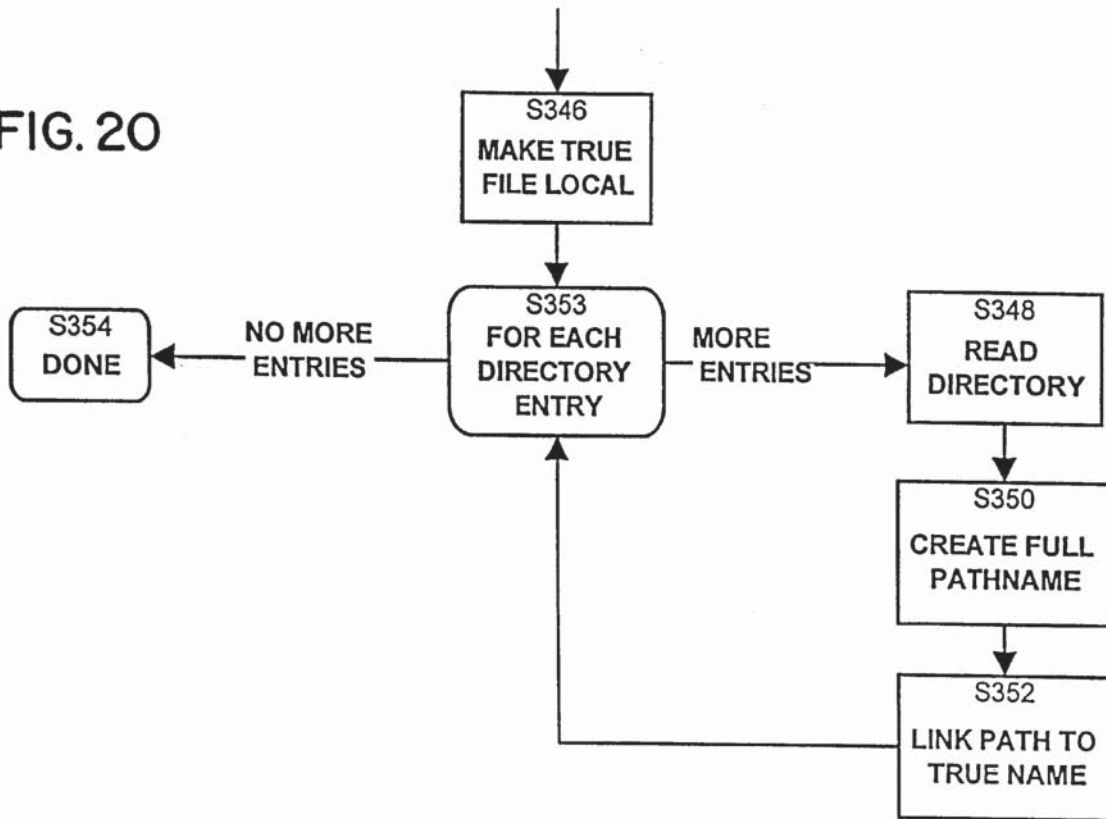

FIG. 21

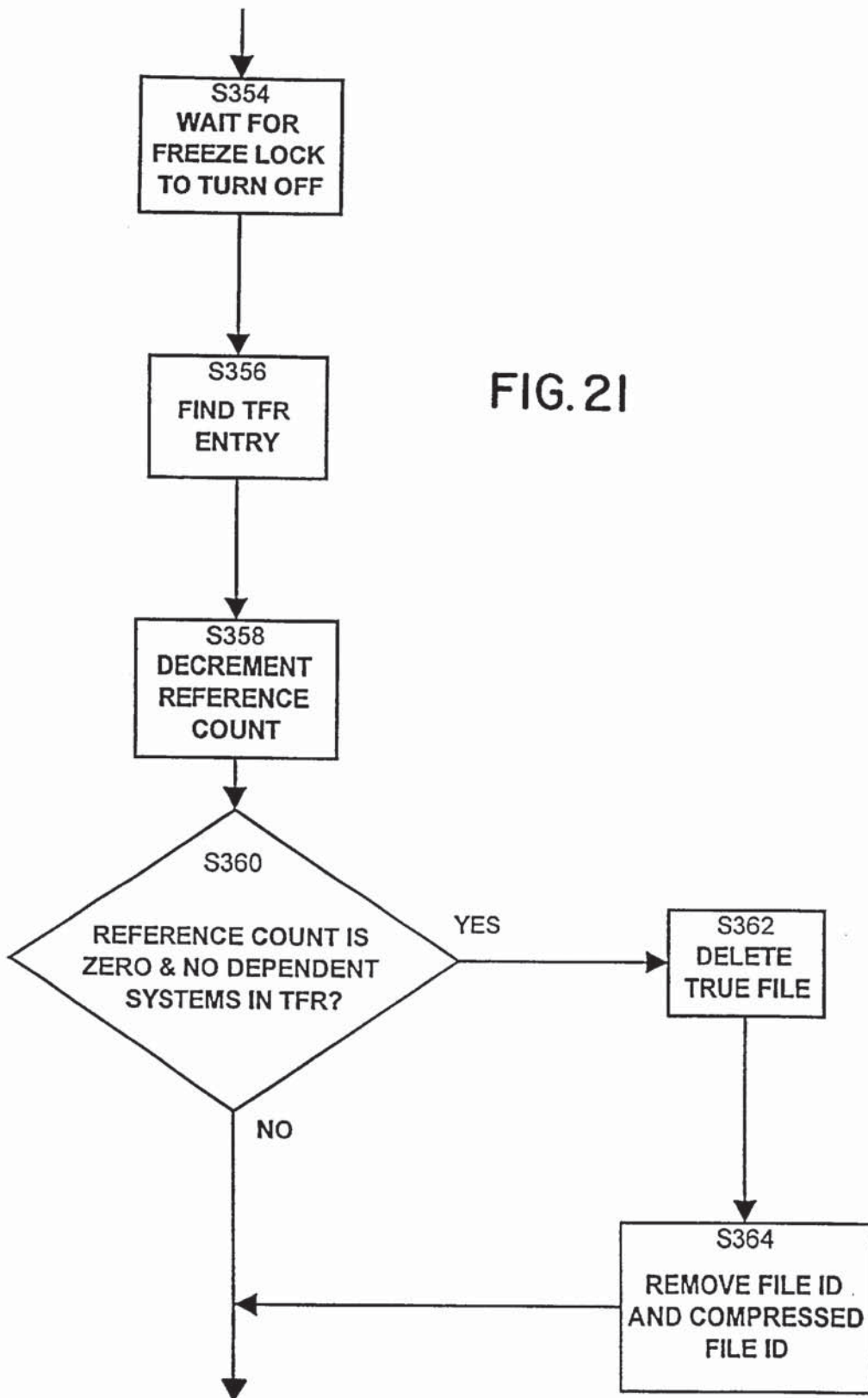

FIG. 22

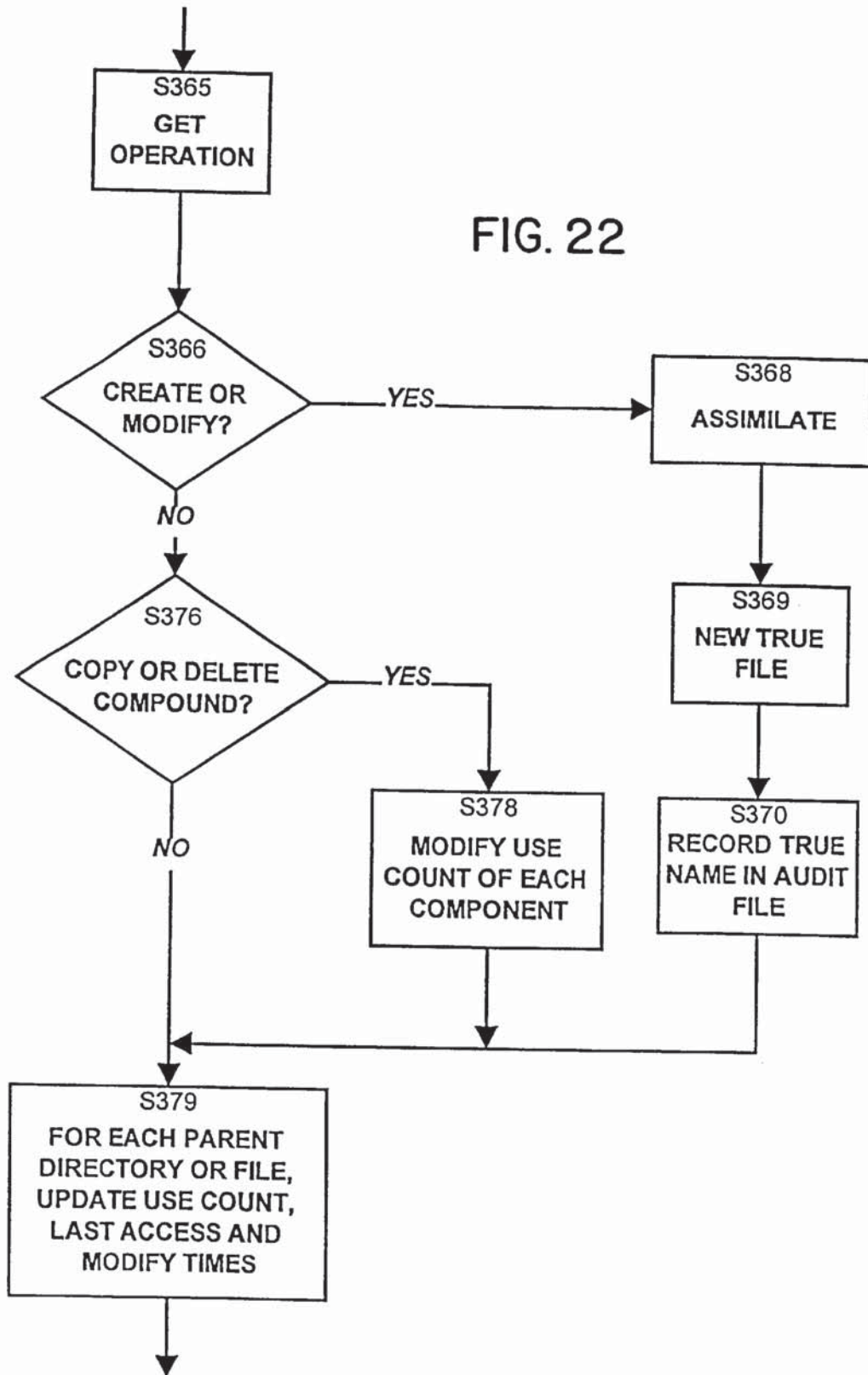
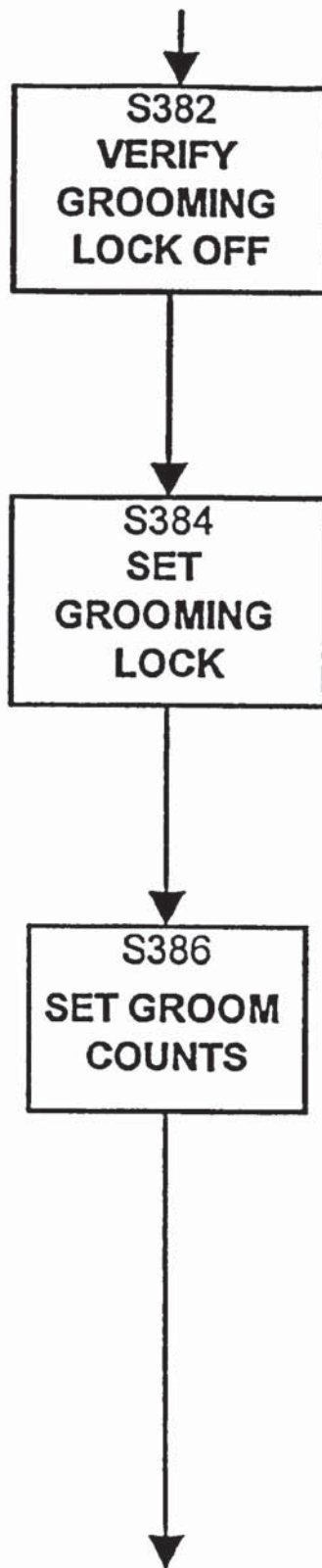

FIG. 23



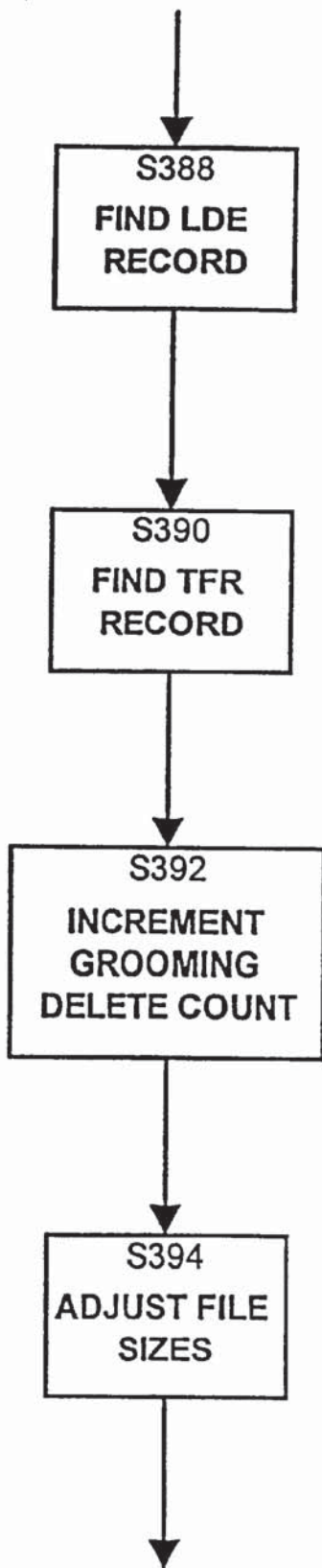
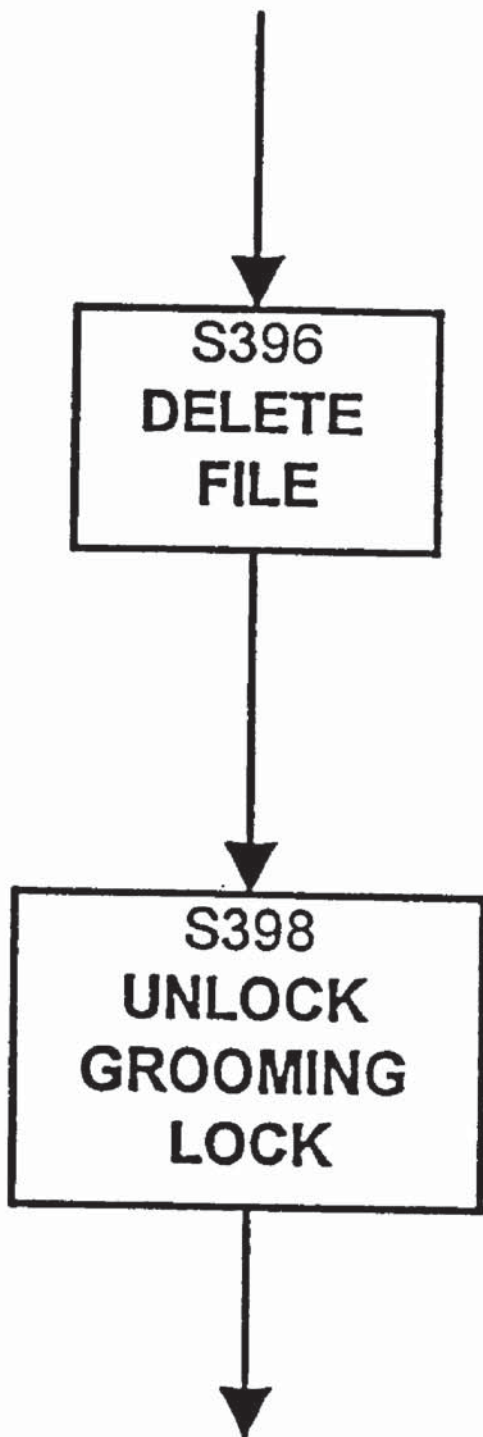
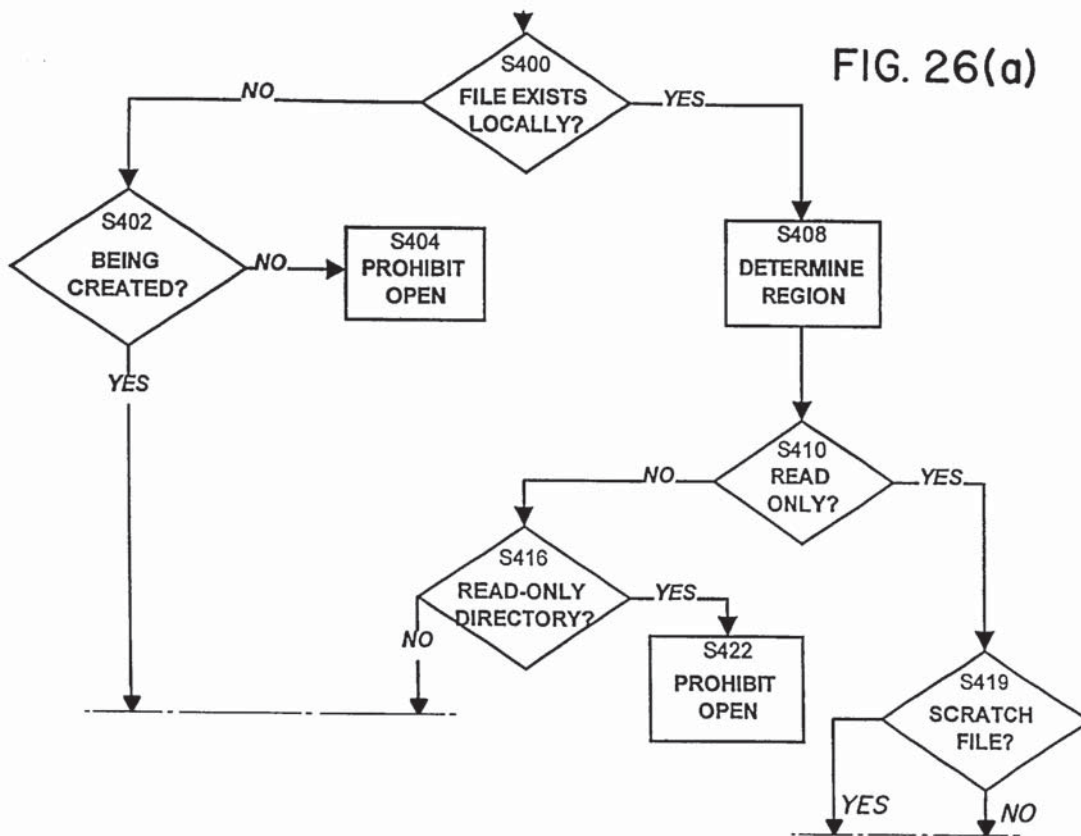

FIG. 24

FIG. 25





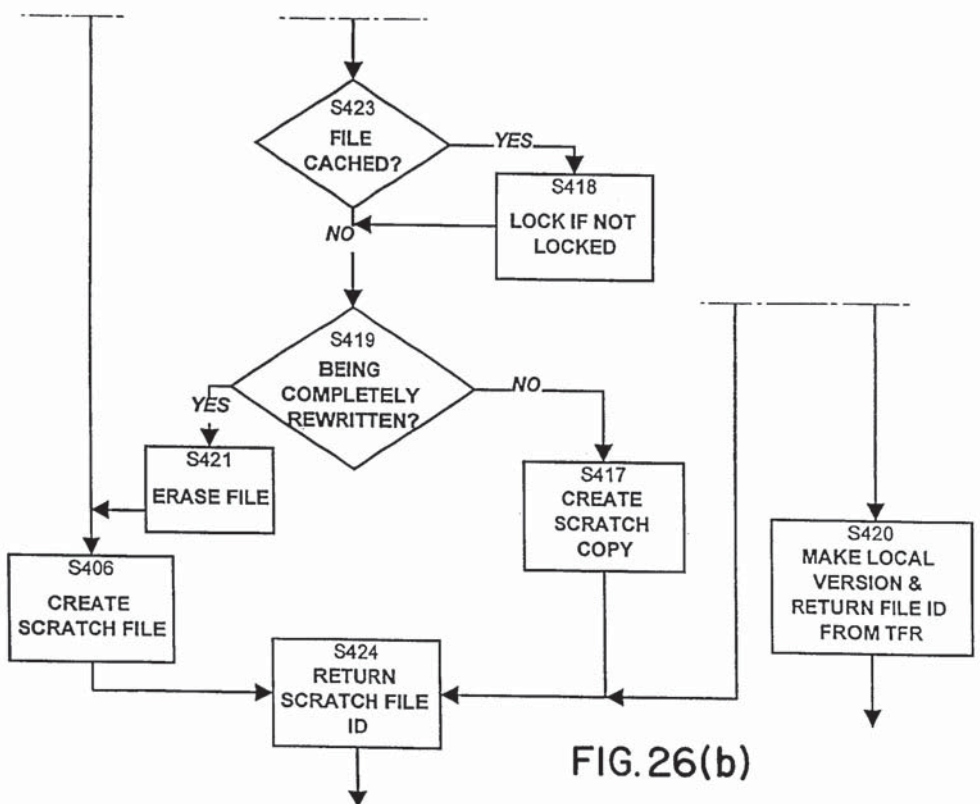

FIG. 26(b)

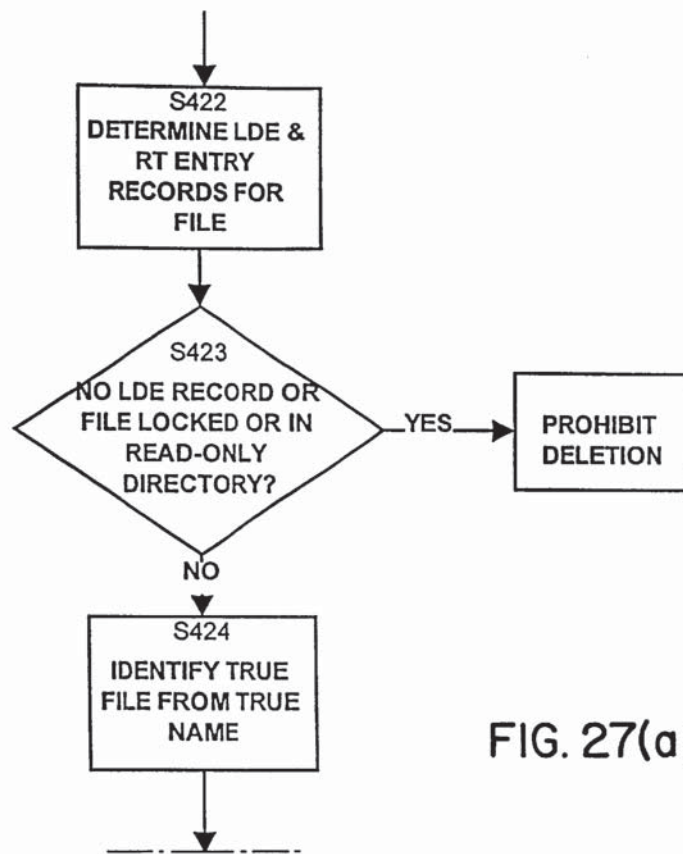

FIG. 27(a)

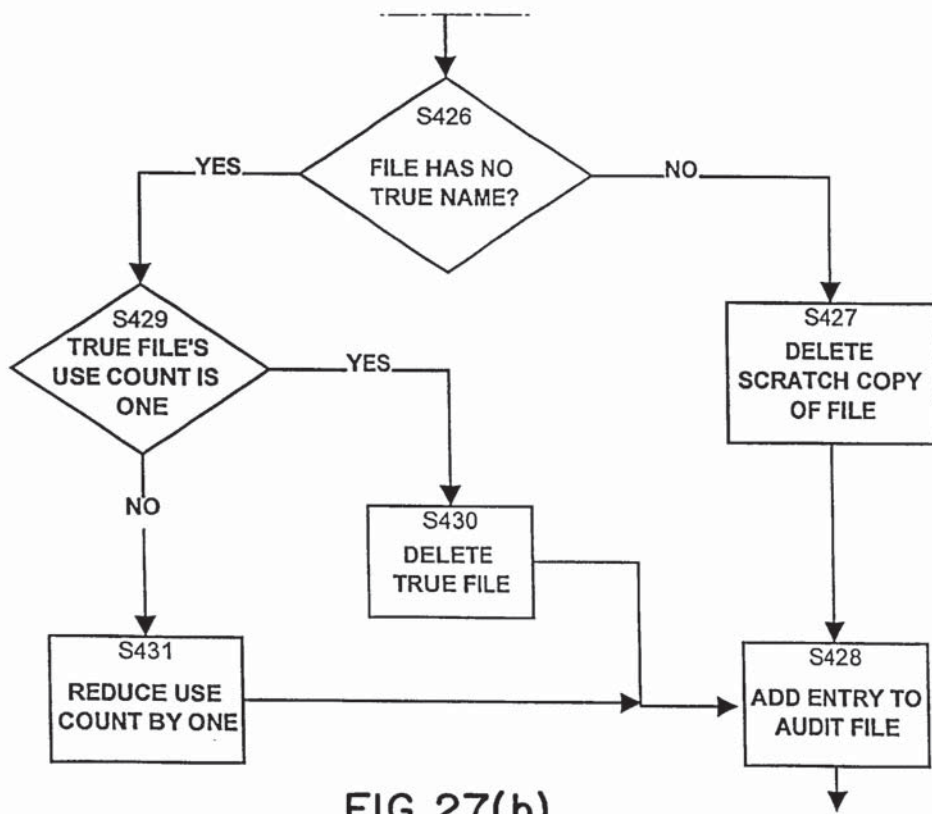
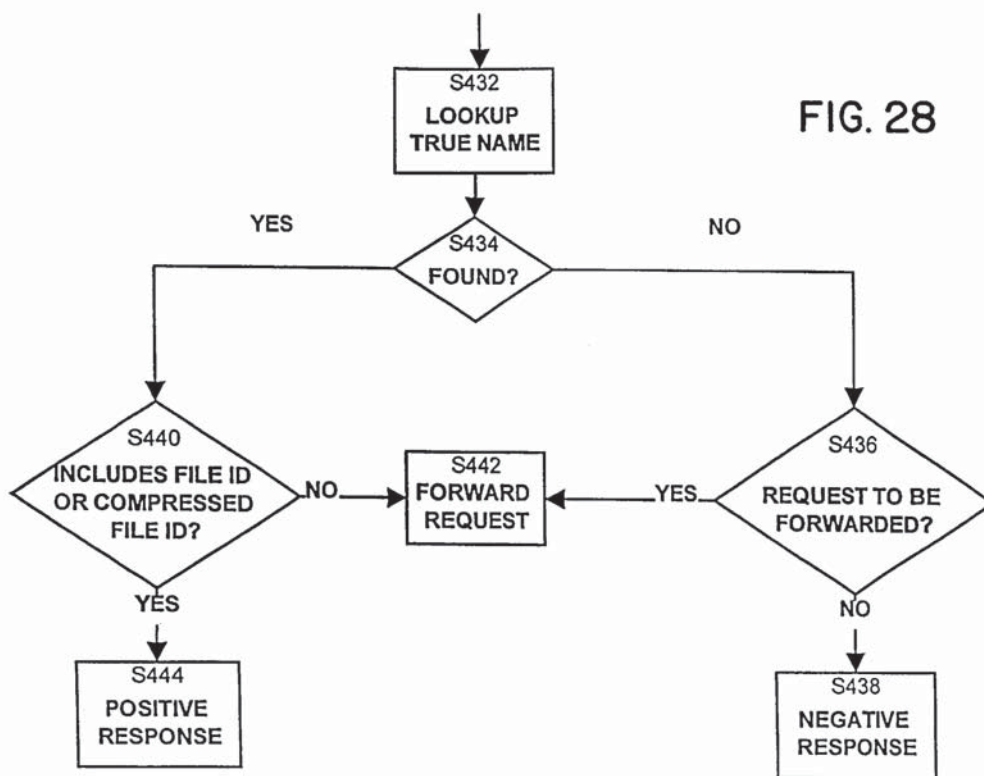

FIG. 27(b)

FIG. 28



**IDENTIFYING AND REQUESTING DATA IN
NETWORK USING IDENTIFIERS WHICH
ARE BASED ON CONTENTS OF DATA**

This is a division of application Ser. No. 08/960,079, filed Oct. 24, 1997, now U.S. Pat. No. 5,978,791 filed Oct. 24, 2001 which is a continuation of Ser. No. 08/425,160, filed Apr. 11, 1995, now abandoned.

BACKGROUND OF THE INVENTION

1. Field of the Invention

This invention relates to data processing systems and, more particularly, to data processing systems wherein data items are identified by substantially unique identifiers which depend on all of the data in the data items and only on the data in the data items.

2. Background of the Invention

Data processing (DP) systems, computers, networks of computers, or the like, typically offer users and programs various ways to identify the data in the systems.

Users typically identify data in the data processing system by giving the data some form of name. For example, a typical operating system (OS) on a computer provides a file system in which data items are named by alphanumeric identifiers. Programs typically identify data in the data processing system using a location or address. For example, a program may identify a record in a file or database by using a record number which serves to locate that record.

In all but the most primitive operating systems, users and programs are able to create and use collections of named data items, these collections themselves being named by identifiers. These named collections can then, themselves, be made part of other named collections. For example, an OS may provide mechanisms to group files (data items) into directories (collections). These directories can then, themselves be made part of other directories. A data item may thus be identified relative to these nested directories using a sequence of names, or a so-called pathname, which defines a path through the directories to a particular data item (file or directory).

As another example, a database management system may group data records (data items) into tables and then group these tables into database files (collections). The complete address of any data record can then be specified using the database file name, the table name, and the record number of that data record.

Other examples of identifying data items include: identifying files in a network file system, identifying objects in an object-oriented database, identifying images in an image database, and identifying articles in a text database.

In general, the terms "data" and "data item" as used herein refer to sequences of bits. Thus a data item may be the contents of a file, a portion of a file, a page in memory, an object in an object-oriented program, a digital message, a digital scanned image, a part of a video or audio signal, or any other entity which can be represented by a sequence of bits. The term "data processing" herein refers to the processing of data items, and is sometimes dependent on the type of data item being processed. For example, a data processor for a digital image may differ from a data processor for an audio signal.

In all of the prior data processing systems the names or identifiers provided to identify data items (the data items being files, directories, records in the database, objects in object-oriented programming, locations in memory or on a

physical device, or the like) are always defined relative to a specific context. For instance, the file identified by a particular file name can only be determined when the directory containing the file (the context) is known. The file identified by a pathname can be determined only when the file system (context) is known. Similarly, the addresses in a process address space, the keys in a database table, or domain names on a global computer network such as the Internet are meaningful only because they are specified relative to a context.

In prior art systems for identifying data items there is no direct relationship between the data names and the data item. The same data name in two different contexts may refer to different data items, and two different data names in the same context may refer to the same data item.

In addition, because there is no correlation between a data name and the data it refers to, there is no a priori way to confirm that a given data item is in fact the one named by a data name. For instance, in a DP system, if one processor requests that another processor deliver a data item with a given data name, the requesting processor cannot, in general, verify that the data delivered is the correct data (given only the name). Therefore it may require further processing, typically on the part of the requestor, to verify that the data item it has obtained is, in fact, the item it requested.

A common operation in a DP system is adding a new data item to the system. When a new data item is added to the system, a name can be assigned to it only by updating the context in which names are defined. Thus such systems require a centralized mechanism for the management of names. Such a mechanism is required even in a multi-processing system when data items are created and identified at separate processors in distinct locations, and in which there is no other need for communication when data items are added.

In many data processing systems or environments, data items are transferred between different locations in the system. These locations may be processors in the data processing system, storage devices, memory, or the like. For example, one processor may obtain a data item from another processor or from an external storage device, such as a floppy disk, and may incorporate that data item into its system (using the name provided with that data item).

However, when a processor (or some location) obtains a data item from another location in the DP system, it is possible that this obtained data item is already present in the system (either at the location of the processor or at some other location accessible by the processor) and therefore a duplicate of the data item is created. This situation is common in a network data processing environment where proprietary software products are installed from floppy disks onto several processors sharing a common file server. In these systems, it is often the case that the same product will be installed on several systems, so that several copies of each file will reside on the common file server.

In some data processing systems in which several processors are connected in a network, one system is designated as a cache server to maintain master copies of data items, and other systems are designated as cache clients to copy local copies of the master data items into a local cache on an as-needed basis. Before using a cached item, a cache client must either reload the cached item, be informed of changes to the cached item, or confirm that the master item corresponding to the cached item has not changed. In other words, a cache client must synchronize its data items with those on

3

the cache server. This synchronization may involve reloading data items onto the cache client. The need to keep the cache synchronized or reload it adds significant overhead to existing caching mechanisms.

In view of the above and other problems with prior art systems, it is therefore desirable to have a mechanism which allows each processor in a multiprocessor system to determine a common and substantially unique identifier for a data item, using only the data in the data item and not relying on any sort of context.

It is further desirable to have a mechanism for reducing multiple copies of data items in a data processing system and to have a mechanism which enables the identification of identical data items so as to reduce multiple copies. It is further desirable to determine whether two instances of a data item are in fact the same data item, and to perform various other systems' functions and applications on data items without relying on any context information or properties of the data item.

It is also desirable to provide such a mechanism in such a way as to make it transparent to users of the data processing system, and it is desirable that a single mechanism be used to address each of the problems described above.

SUMMARY OF THE INVENTION

This invention provides, in a data processing system, a method and apparatus for identifying a data item in the system, where the identity of the data item depends on all of the data in the data item and only on the data in the data item. Thus the identity of a data item is independent of its name, origin, location, address, or other information not derivable directly from the data, and depends only on the data itself.

This invention further provides an apparatus and a method for determining whether a particular data item is present in the system or at a location in the system, by examining only the data identities of a plurality of data items.

Using the method or apparatus of the present invention, the efficiency and integrity of a data processing system can be improved. The present invention improves the design and operation of a data storage system, file system, relational database, object-oriented database, or the like that stores a plurality of data items, by making possible or improving the design and operation of at least some or all of the following features:

- the system stores at most one copy of any data item at a given location, even when multiple data names in the system refer to the same contents;
- the system avoids copying data from source to destination locations when the destination locations already have the data;
- the system provides transparent access to any data item by reference only to its identity and independent of its present location, whether it be local, remote, or offline;
- the system caches data items from a server, so that only the most recently accessed data items need be retained;
- when the system is being used to cache data items, problems of maintaining cache consistency are avoided;
- the system maintains a desired level of redundancy of data items in a network of servers, to protect against failure by ensuring that multiple copies of the data items are present at different locations in the system;
- the system automatically archives data items as they are created or modified;

4

the system provides the size, age, and location of groups of data items in order to decide whether they can be safely removed from a local file system;

the system can efficiently record and preserve any collection of data items;

the system can efficiently make a copy of any collection of data items, to support a version control mechanism for groups of the data items;

the system can publish data items, allowing other, possibly anonymous, systems in a network to gain access to the data items and to rely on the availability of the data items;

the system can maintain a local inventory of all the data items located on a given removable medium, such as a diskette or CD-ROM, the inventory is independent of other properties of the data items such as their name, location, and date of creation;

the system allows closely related sets of data items, such as matching or corresponding directories on disconnected computers, to be periodically resynchronized with one another;

the system can verify that data retrieved from another location is the desired or requested data, using only the data identifier used to retrieve the data;

the system can prove possession of specific data items by content without disclosing the content of the data items, for purposes of later legal verification and to provide anonymity;

the system tracks possession of specific data items according to content by owner, independent of the name, date, or other properties of the data item, and tracks the uses of specific data items and files by content for accounting purposes.

Other objects, features, and characteristics of the present invention as well as the methods of operation and functions of the related elements of structure, and the combination of parts and economies of manufacture, will become more apparent upon consideration of the following description and the appended claims with reference to the accompanying drawings, all of which form a part of this specification.

BRIEF DESCRIPTION OF THE DRAWINGS

FIGS. 1(a) and 1(b) depict a typical data processing system in which a preferred embodiment of the present invention operates;

FIG. 2 depicts a hierarchy of data items stored at any location in such a data processing system;

FIGS. 3-9 depict data structures used to implement an embodiment of the present invention; and

FIGS. 10(a)-28 are flow charts depicting operation of various aspects of the present invention.

DETAILED DESCRIPTION OF THE PRESENTLY PREFERRED EXEMPLARY EMBODIMENTS

An embodiment of the present invention is now described with reference to a typical data processing system 100, which, with reference to FIGS. 1(a) and 1(b), includes one or more processors (or computers) 102 and various storage devices 104 connected in some way, for example by a bus 106.

Each processor 102 includes a CPU 108, a memory 110 and one or more local storage devices 112. The CPU 108, memory 110, and local storage device 112 may be internally

connected, for example by a bus 114. Each processor 102 may also include other devices (not shown), such as a keyboard, a display, a printer, and the like.

In a data processing system 100, wherein more than one processor 102 is used, that is, in a multiprocessor system, the processors may be in one of various relationships. For example, two processors 102 may be in a client/server, client/client, or a server/server relationship. These inter-processor relationships may be dynamic, changing depending on particular situations and functions. Thus, a particular processor 102 may change its relationship to other processors as needed, essentially setting up a peer-to-peer relationship with other processors. In a peer-to-peer relationship, sometimes a particular processor 102 acts as a client processor, whereas at other times the same processor acts as a server processor. In other words, there is no hierarchy imposed on or required of processors 102.

In a multiprocessor system, the processors 102 may be homogeneous or heterogeneous. Further, in a multiprocessor data processing system 100, some or all of the processors 102 may be disconnected from the network of processors for periods of time. Such disconnection may be part of the normal operation of the system 100 or it may be because a particular processor 102 is in need of repair.

Within a data processing system 100, the data may be organized to form a hierarchy of data storage elements, wherein lower level data storage elements are combined to form higher level elements. This hierarchy can consist of, for example, processors, file systems, regions, directories, data files, segments, and the like. For example, with reference to FIG. 2, the data items on a particular processor 102 may be organized or structured as a file system 116 which comprises regions 117, each of which comprises directories 118, each of which can contain other directories 118 or files 120. Each file 120 being made up of one or more data segments 122.

In a typical data processing system, some or all of these elements can be named by users given certain implementation specific naming conventions, the name (or pathname) of an element being relative to a context. In the context of a data processing system 100, a pathname is fully specified by a processor name, a filesystem name, a sequence of zero or more directory names identifying nested directories, and a final file name. (Usually the lowest level elements, in this case segments 122, cannot be named by users.)

In other words, a file system 116 is a collection of directories 118. A directory 118 is a collection of named files 120—both data files 120 and other directory files 118. A file 120 is a named data item which is either a data file (which may be simple or compound) or a directory file 118. A simple file 120 consists of a single data segment 122. A compound file 120 consists of a sequence of data segments 122. A data segment 122 is a fixed sequence of bytes. An important property of any data segment is its size, the number of bytes in the sequence.

A single processor 102 may access one or more file systems 116, and a single storage device 104 may contain one or more file systems 116, or portions of a file system 116. For instance, a file system 116 may span several storage devices 104.

In order to implement controls in a file system, file system 116 may be divided into distinct regions, where each region is a unit of management and control. A region consists of a given directory 118 and is identified by the pathname (user defined) of the directory.

In the following, the term “location”, with respect to a data processing system 100, refers to any of a particular

processor 102 in the system, a memory of a particular processor, a storage device, a removable storage medium (such as a floppy disk or compact disk), or any other physical location in the system. The term “local” with respect to a particular processor 102 refers to the memory and storage devices of that particular processor.

In the following, the terms “True Name”, “data identity” and “data identifier” refer to the substantially unique data identifier for a particular data item. The term “True File” refers to the actual file, segment, or data item identified by a True Name.

A file system for a data processing system 100 is now described which is intended to work with an existing operating system by augmenting some of the operating system’s file management system codes. The embodiment provided relies on the standard file management primitives for actually storing to and retrieving data items from disk, but uses the mechanisms of the present invention to reference and access those data items.

The processes and mechanisms (services) provided in this embodiment are grouped into the following categories: primitive mechanisms, operating system mechanisms, remote mechanisms, background mechanisms, and extended mechanisms.

Primitive mechanisms provide fundamental capabilities used to support other mechanisms. The following primitive mechanisms are described:

1. Calculate True Name;
2. Assimilate Data Item;
3. New True File;
4. Get True Name from Path;
5. Link path to True Name;
6. Realize True File from Location;
7. Locate Remote File;
8. Make True File Local;
9. Create Scratch File;
10. Freeze Directory;
11. Expand Frozen Directory;
12. Delete True File;
13. Process Audit File Entry;
14. Begin Grooming;
15. Select For Removal; and
16. End Grooming.

Operating system mechanisms provide typical familiar file system mechanisms, while maintaining the data structures required to offer the mechanisms of the, present invention. Operating system mechanisms are designed to augment existing operating systems, and in this way to make the present invention compatible with, and generally transparent to, existing applications. The following operating system mechanisms are described:

1. Open File;
2. Close File;
3. Read File;
4. Write File;
5. Delete File or Directory;
6. Copy File or Directory;
7. Move File or Directory;
8. Get File Status; and
9. Get Files in Directory.

Remote mechanisms are used by the operating system in responding to requests from other processors. These mecha-

nisms enable the capabilities of the present invention in a peer-to-peer network mode of operation. The following remote mechanisms are described:

1. Locate True File;
2. Reserve True File;
3. Request True File;
4. Retire True File;
5. Cancel Reservation;
6. Acquire True File;
7. Lock Cache;
8. Update Cache; and
9. Check Expiration Date.

Background mechanisms are intended to run occasionally and at a low priority. These provide automated management capabilities with respect to the present invention. The following background mechanisms are described:

1. Mirror True File;
2. Groom Region;
3. Check for Expired Links; and
4. Verify Region; and
5. Groom Source List.

Extended mechanisms run within application programs over the operating system. These mechanisms provide solutions to specific problems and applications. The following extended mechanisms are described:

1. Inventory Existing Directory;
2. Inventory Removable, Read-only Files;
3. Synchronize directories;
4. Publish Region;
5. Retire Directory;
6. Realize Directory at location;
7. Verify True File;
8. Track for accounting purposes; and
9. Track for licensing purposes.

The file system herein described maintains sufficient information to provide a variety of mechanisms not ordinarily offered by an operating system, some of which are listed and described here. Various processing performed by this embodiment of the present invention will now be described in greater detail.

In some embodiments, some files **120** in a data processing system **100** do not have True Names because they have been recently received or created or modified, and thus their True Names have not yet been computed. A file that does not yet have a True Name is called a scratch file. The process of assigning a True Name to a file is referred to as assimilation, and is described later. Note that a scratch file may have a user provided name.

Some of the processing performed by the present invention can take place in a background mode or on a delayed or as-needed basis. This background processing is used to determine information that is not immediately required by the system or which may never be required. As an example, in some cases a scratch file is being changed at a rate greater than the rate at which it is useful to determine its True Name. In these cases, determining the True Name of the file can be postponed or performed in the background.

Data Structures

The following data structures, stored in memory **110** of one of more processors **102** are used to implement the mechanisms described herein. The data structures can be

local to each processor **102** of the system **100**, or they can reside on only some of the processors **102**.

The data structures described are assumed to reside on individual peer processors **102** in the data processing system **100**. However, they can also be shared by placing them on a remote, shared file server (for instance, in a local area network of machines). In order to accommodate sharing data structures, it is necessary that the processors accessing the shared database use the appropriate locking techniques to ensure that changes to the shared database do not interfere with one another but are appropriately serialized. These locking techniques are well understood by ordinarily skilled programmers of distributed applications.

It is sometimes desirable to allow some regions to be local to a particular processor **102** and other regions to be shared among processors **102**. (Recall that a region is a unit of file system management and control consisting of a given directory identified by the pathname of the directory.) In the case of local and shared regions, there would be both local and shared versions of each data structure. Simple changes to the processes described below must be made to ensure that appropriate data structures are selected for a given operation.

The local directory extensions (LDE) table **124** is a data structure which provides information about files **120** and directories **118** in the data processing system **100**. The local directory extensions table **124** is indexed by a pathname or contextual name (that is, a user provided name) of a file and includes the True Name for most files. The information in local directory extension table **124** is in addition to that provided by the native file system of the operating system.

The True File registry (TFR) **126** is a data store for listing actual data items which have True Names, both files **120** and segments **122**. When such data items occur in the True File registry **126** they are known as True Files. True Files are identified in True File registry **126** by their True Names or identities. The table True File registry **126** also stores location, dependency, and migration information about True Files.

The region table (RT) **128** defines areas in the network storage which are to be managed separately. Region table **128** defines the rules for access to and migration of files **120** among various regions with the local file system **116** and remote peer file systems.

The source table (ST) **130** is a list of the sources of True Files other than the current True File registry **126**. The source table **130** includes removable volumes and remote processors.

The audit file (AF) **132** is a list of records indicating changes to be made in local or remote files, these changes to be processed in background.

The accounting log (AL) **134** is a log of file transactions used to create accounting information in a manner which preserves the identity of files being tracked independent of their name or location.

The license table (LT) **136** is a table identifying files, which may only be used by licensed users, in a manner independent of their name or location, and the users licensed to use them.

Detailed Descriptions of the Data Structures

The following table summarizes the fields of an local directory extensions table entry, as illustrated by record **138** in FIG. 3.

Field	Description
Region ID	identifies the region in which this file is contained.
Pathname	the user provided name or contextual name of the file or directory, relative to the region in which it occurs.
True Name	the computed True Name or identity of the file or directory. This True Name is not always up to date, and it is set to a special value when a file is modified and is later recomputed in the background.
Type	indicates whether the file is a data file or a directory.
Scratch File ID	the physical location of the file in the file system, when no True Name has been calculated for the file. As noted above, such a file is called a scratch file.
Time of last access	the last access time to this file. If this file is a directory, this is the last access time to any file in the directory.
Time of last modification	the time of last change of this file. If this file is a directory, this is the last modification time of any file in the directory.
Safe flag	indicates that this file (and, if this file is a directory, all of its subordinate files) have been backed up on some other system, and it is therefore safe to remove them.
Lock flag	indicates whether a file is locked, that is, it is being modified by the local processor or a remote processor. Only one processor may modify a file at a time.
Size	the full size of this directory (including all subordinate files), if all files in it were fully expanded and duplicated. For a file that is not a directory this is the size of the actual True File.
Owner	the identity of the user who owns this file, for accounting and license tracking purposes.

Each record of the True File registry 126 has the fields shown in the True File registry record 140 in FIG. 4. The True File registry 126 consists of the database described in the table below as well as the actual True Files identified by the True File IDs below.

Field	Description
True Name	computed True Name or identity of the file.
Compressed File ID	compressed version of the True File may be stored instead of, or in addition to, an uncompressed version. This field provides the identity of the actual representation of the compressed version of the file.
Grooming delete count	tentative count of how many references have been selected for deletion during a grooming operation.
Time of last access	most recent date and time the content of this file was accessed.
Expiration	date and time after which this file may be deleted by this server.
Dependent processors	processor IDs of other processors which contain references to this True File.
Source IDs	source ID(s) of zero or more sources from which this file or data item may be retrieved.
True File ID	identity or disk location of the actual physical representation of the file or file segment. It is sufficient to use a filename in the registration directory of the underlying operating system. The True File ID is absent if the actual file is not currently present at the current location.
Use count	number of other records on this processor which identify this True File.

A region table 128, specified by a directory pathname, records storage policies which allow files in the file system

to be stored, accessed and migrated in different ways. Storage policies are programmed in a configurable way using a set of rules described below.

Each region table record 142 of region table 128 includes the fields described in the following table (with reference to FIG. 5):

Field	Description
Region ID	internally used identifier for this region.
Region file system	file system on the local processor of which this region is a part.
Region pathname	a pathname relative to the region file system which defines the location of this region. The region consists of all files and directories subordinate to this pathname, except those in a region subordinate to this region.
Mirror processor(s)	zero or more identifiers of processors which are to keep mirror or archival copies of all files in the current region. Multiple mirror processors can be defined to form a mirror group.
Mirror duplication count	number of copies of each file in this region that should be retained in a mirror group.
Region status	specifies whether this region is local to a single processor 102, shared by several processors 102 (if, for instance, it resides on a shared file server), or managed by a remote processor.
Policy	the migration policy to apply to this region. A single region might participate in several policies. The policies are as follows (parameters in brackets are specified as part of the policy): region is a cached version from [processor ID]; region is a member of a mirror set defined by [processor ID]. region is to be archived on [processor ID]. region is to be backed up locally, by placing new copies in [region ID]. region is read only and may not be changed. region is published and expires on [date]. Files in this region should be compressed.

A source table 130 identifies a source location for True Files. The source table 130 is also used to identify client processors making reservations on the current processor. Each source record 144 of the source table 130 includes the fields summarized in the following table, with reference to FIG. 6:

Field	Description
source ID	internal identifier used to identify a particular source.
source type	type of source location: Removable Storage Volume Local Region Cache Server Mirror Group Server Cooperative Server Publishing Server Client
source rights	includes information about the rights of this processor, such as whether it can ask the local processor to store data items for it.
source availability	measurement of the bandwidth, cost, and reliability of the connection to this source of True Files. The availability is used to select

-continued

Field	Description
source location	from among several possible sources. information on how the local processor is to access the source. This may be, for example, the name of a removable storage volume, or the processor ID and region path of a region on a remote processor.

The audit file 132 is a table of events ordered by timestamp, each record 146 in audit file 132 including the fields summarized in the following table (with reference to FIG. 7):

Field	Description
Original Name	path of the file in question.
Operation	whether the file was created, read, written, copied or deleted.
Type	specifies whether the source is a file or a directory.
Processor ID	ID of the remote processor generating this event (if not local).
Timestamp	time and date file was closed (required only for accessed/modified files).
Pathname	Name of the file (required only for rename).
True Name	computed True Name of the file. This is used by remote systems to mirror changes to the directory and is filled in during background processing.

Each record 148 of the accounting log 134 records an event which may later be used to provide information for billing mechanisms. Each accounting log entry record 148 includes at least the information summarized in the following table, with reference to FIG. 8:

Field	Description
date of entry	date and time of this log entry.
type of entry	Entry types include create file, delete file, and transmit file.
True Name	True Name of data item in question.
owner	identity of the user responsible for this action.

Each record 150 of the license table 136 records a relationship between a licensable data item and the user licensed to have access to it. Each license table record 150 includes the information summarized in the following table, with reference to FIG. 9:

Field	Description
True Name	True Name of a data item subject to license validation.
licensee	identity of a user authorized to have access to this object.

Various other data structures are employed on some or all of the processors 102 in the data processing system 100. Each processor 102 has a global freeze lock (GFL) 152 (FIG. 1), which is used to prevent synchronization errors when a directory is frozen or copied. Any processor 102 may include a special archive directory (SAD) 154 into which directories may be copied for the purposes of archival. Any processor 102 may include a special media directory (SMD) 156, into which the directories of removable volumes are stored to form a media inventory. Each processor has a

grooming lock 158, which is set during a grooming operation. During this period the grooming delete count of True File registry entries 140 is active, and no True Files should be deleted until grooming is complete. While grooming is in effect, grooming information includes a table of pathnames selected for deletion, and keeps track of the amount of space that would be freed if all of the files were deleted.

Primitive Mechanisms

The first of the mechanisms provided by the present invention, primitive mechanisms, are now described. The mechanisms described here depend on underlying data management mechanisms to create, copy, read, and delete data items in the True File registry 126, as identified by a True File ID. This support may be provided by an underlying operating system or disk storage manager.

The following primitive mechanisms are described:

1. Calculate True Name;
2. Assimilate Data Item;
3. New True File;
4. Get True Name from Path;
5. Link Path to True Name;
6. Realize True File from Location;
7. Locate Remote File;
8. Make True File Local;
9. Create Scratch File;
10. Freeze Directory;
11. Expand Frozen Directory;
12. Delete True File;
13. Process Audit File Entry;
14. Begin Grooming;
15. Select For Removal; and
16. End Grooming.

1. Calculate True Name
A True Name is computed using a function, MD, which reduces a data block B of arbitrary length to a relatively small, fixed size identifier, the True Name of the data block, such that the True Name of the data block is virtually guaranteed to represent the data block B and only data block B.

The function MD must have the following properties:

1. The domain of the function MD is the set of all data items. The range of the function MD is the set of True Names.
2. The function MD must take a data item of arbitrary length and reduce it to an integer value in the range 0 to N-1, where N is the cardinality of the set of True Names. That is, for an arbitrary length data block B, $0 \leq MD(B) < N$.
3. The results of MD(B) must be evenly and randomly distributed over the range of N, in such a way that simple or regular changes to B are virtually guaranteed to produce a different value of MD(B).
4. It must be computationally difficult to find a different value B' such that MD(B)=MD(B').
5. The function MD(B) must be efficiently computed.

A family of functions with the above properties are the so-called message digest functions, which are used in digital security systems as techniques for authentication of data. These functions (or algorithms) include MD4, MD5, and SHA.

In the presently preferred embodiments, either MD5 or SHA is employed as the basis for the computation of True

Names. Whichever of these two message digest functions is employed, that same function must be employed on a system-wide basis.

It is impossible to define a function having a unique output for each possible input when the number of elements in the range of the function is smaller than the number of elements in its domain. However, a crucial observation is that the actual data items that will be encountered in the operation of any system embodying this invention form a very sparse subset of all the possible inputs.

A colliding set of data items is defined as a set wherein, for one or more pairs x and y in the set, $MD(x)=MD(y)$. Since a function conforming to the requirements for MD must evenly and randomly distribute its outputs, it is possible, by making the range of the function large enough, to make the probability arbitrarily small that actual inputs encountered in the operation of an embodiment of this invention will form a colliding set.

To roughly quantify the probability of a collision, assume that there are no more than 2^{30} storage devices in the world, and that each storage device has an average of at most 2^{20} different data items. Then there are at most 2^{50} data items in the world. If the outputs of MD range between 0 and 2^{128} , it can be demonstrated that the probability of a collision is approximately 1 in 2^{29} . Details on the derivation of these probability values are found, for example, in P. Flajolet and A. M. Odlyzko, "Random Mapping Statistics," *Lecture Notes in Computer Science 434: Advances in Cryptology—Eurocrypt '89 Proceedings*, Springer-Verlag, pp. 329–354.

Note that for some less preferred embodiments of the present invention, lower probabilities of uniqueness may be acceptable, depending on the types of applications and mechanisms used. In some embodiments it may also be useful to have more than one level of True Names, with some of the True Names having different degrees of uniqueness. If such a scheme is implemented, it is necessary to ensure that less unique True Names are not propagated in the system.

While the invention is described herein using only the True Name of a data item as the identifier for the data item, other preferred embodiments use tagged, typed, categorized or classified data items and use a combination of both the True Name and the tag, type, category or class of the data item as an identifier. Examples of such categorizations are files, directories, and segments; executable files and data files, and the like. Examples of classes are classes of objects in an object-oriented system. In such a system, a lower degree of True Name uniqueness is acceptable over the entire universe of data items, as long as sufficient uniqueness is provided per category of data items. This is because the tags provide an additional level of uniqueness.

A mechanism for calculating a True Name given a data item is now described, with reference to FIGS. 10(a) and 10(b).

A simple data item is a data item whose size is less than a particular given size (which must be defined in each particular implementation of the invention). To determine the True Name of a simple data item, with reference to FIG. 10(a), first compute the MD function (described above) on the given simple data item (Step S212). Then append to the resulting 128 bits, the byte length modulo 32 of the data item (Step S214). The resulting 160-bit value is the True Name of the simple data item.

A compound data item is one whose size is greater than the particular given size of a simple data item. To determine the True Name of an arbitrary (simple or compound) data item, with reference to FIG. 10(b), first determine if the data

item is a simple or a compound data item (Step S216). If the data item is a simple data item, then compute its True Name in step S218 (using steps S212 and S214 described above), otherwise partition the data item into segments (Step S220) and assimilate each segment (Step S222) (the primitive mechanism, Assimilate a Data Item, is described below), computing the True Name of the segment. Then create an indirect block consisting of the computed segment True Names (Step S224). An indirect block is a data item which consists of the sequence of True Names of the segments. Then, in step S226, assimilate the indirect block and compute its True Name. Finally, replace the final thirty-two (32) bits of the resulting True Name (that is, the length of the indirect block) by the length modulo 32 of the compound data item (Step S228). The result is the True Name of the compound data item.

Note that the compound data item may be so large that the indirect block of segment True Names is itself a compound data item. In this case the mechanism is invoked recursively until only simple data items are being processed.

Both the use of segments and the attachment of a length to the True Name are not strictly required in a system using the present invention, but are currently considered desirable features in the preferred embodiment.

2. Assimilate Data Item

A mechanism for assimilating a data item (scratch file or segment) into a file system, given the scratch file ID of the data item, is now described with reference to FIG. 11. The purpose of this mechanism is to add a given data item to the True File registry 126. If the data item already exists in the True File registry 126, this will be discovered and used during this process, and the duplicate will be eliminated.

Thereby the system stores at most one copy of any data item or file by content, even when multiple names refer to the same content.

First, determine the True Name of the data item corresponding to the given scratch File ID using the Calculate True Name primitive mechanism (Step S230). Next, look for an entry for the True Name in the True File registry 126 (Step S232) and determine whether a True Name entry, record 140, exists in the True File registry 126. If the entry record includes a corresponding True File ID or compressed File ID (Step S237), delete the file with the scratch File ID (Step S238). Otherwise store the given True File ID in the entry record (step S239).

If it is determined (in step S232) that no True Name entry exists in the True File registry 126, then, in Step S236, create a new entry in the True File registry 126 for this True Name. Set the True Name of the entry to the calculated True Name, set the use count for the new entry to one, store the given True File ID in the entry and set the other fields of the entry as appropriate.

Because this procedure may take some time to compute, it is intended to run in background after a file has ceased to change. In the meantime, the file is considered an unassimilated scratch file.

3. New True File

The New True File process is invoked when processing the audit file 132, some time after a True File has been assimilated (using the Assimilate Data Item primitive mechanism). Given a local directory extensions table entry record 138 in the local directory extensions table 124, the New True File process can provide the following steps (with reference to FIG. 12), depending on how the local processor is configured:

First, in step S238, examine the local directory extensions table entry record 138 to determine whether the file is locked

by a cache server. If the file is locked, then add the ID of the cache server to the dependent processor list of the True File registry table **126**, and then send a message to the cache server to update the cache of the current processor using the Update Cache remote mechanism (Step **S242**).

If desired, compress the True File (Step **S246**), and, if desired, mirror the True File using the Mirror True File background mechanism (Step **S248**).

4. Get True Name from Path

The True Name of a file can be used to identify a file by contents, to confirm that a file matches its original contents, or to compare two files. The mechanism to get a True Name given the pathname of a file is now described with reference to FIG. **13**.

First, search the local directory extensions table **124** for the entry record **138** with the given pathname (Step **S250**). If the pathname is not found, this process fails and no True Name corresponding to the given pathname exists. Next, determine whether the local directory extensions table entry record **138** includes a True Name (Step **S252**), and if so, the mechanism's task is complete. Otherwise, determine whether the local directory extensions table entry record **138** identifies a directory (Step **S254**), and if so, freeze the directory (Step **S256**) (the primitive mechanism Freeze Directory is described below).

Otherwise, in step **S258**, assimilate the file (using the Assimilate Data Item primitive mechanism) defined by the File ID field to generate its True Name and store its True Name in the local directory extensions entry record. Then return the True Name identified by the local directory extensions table **124**.

5. Link Path to True Name

The mechanism to link a path to a True Name provides a way of creating a new directory entry record identifying an existing, assimilated file. This basic process may be used to copy, move, and rename files without a need to copy their contents. The mechanism to link a path to a True Name is now described with reference to FIG. **14**.

First, if desired, confirm that the True Name exists locally by searching for it in the True Name registry or local directory extensions table **135** (Step **S260**). Most uses of this mechanism will require this form of validation. Next, search for the path in the local directory extensions table **135** (Step **S262**). Confirm that the directory containing the file named in the path already exists (Step **S264**). If the named file itself exists, delete the File using the Delete True File operating system mechanism (see below) (Step **S268**).

Then, create an entry record in the local directory extensions with the specified path (Step **S270**) and update the entry record and other data structures as follows: fill in the True Name field of the entry with the specified True Name; increment the use count for the True File registry entry record **140** of the corresponding True Name; note whether the entry is a directory by reading the True File to see if it contains a tag (magic number) indicating that it represents a frozen directory (see also the description of the Freeze Directory primitive mechanism regarding the tag); and compute and set the other fields of the local directory extensions appropriately. For instance, search the region table **128** to identify the region of the path, and set the time of last access and time of last modification to the current time.

6. Realize True File from Location

This mechanism is used to try to make a local copy of a True File, given its True Name and the name of a source location (processor or media) that may contain the True File. This mechanism is now described with reference to FIG. **15**.

First, in step **S272**, determine whether the location specified is a processor. If it is determined that the location

specified is a processor, then send a Request True File message (using the Request True File remote mechanism) to the remote processor and wait for a response (Step **S274**). If a negative response is received or no response is received after a timeout period, this mechanism fails. If a positive response is received, enter the True File returned in the True File registry **126** (Step **S276**). (If the file received was compressed, enter the True File ID in the compressed File ID field.)

If, on the other hand, it is determined in step **S272** that the location specified is not a processor, then, if necessary, request the user or operator to mount the indicated volume (Step **S278**). Then (Step **S280**) find the indicated file on the given volume and assimilate the file using the Assimilate Data Item primitive mechanism. If the volume does not contain a True File registry **126**, search the media inventory to find the path of the file on the volume. If no such file can be found, this mechanism fails.

At this point, whether or not the location is determined (in step **S272**) to be a processor, if desired, verify the True File (in step **S282**).

7. Locate Remote File

This mechanism allows a processor to locate a file or data item from a remote source of True Files, when a specific source is unknown or unavailable. A client processor system may ask one of several or many sources whether it can supply a data object with a given True Name. The steps to perform this mechanism are as follows (with reference to FIGS. **16(a)** and **16(b)**).

The client processor **102** uses the source table **145** to select one or more source processors (Step **S284**). If no source processor can be found, the mechanism fails. Next, the client processor **102** broadcasts to the selected sources a request to locate the file with the given True Name using the Locate True File remote mechanism (Step **S286**). The request to locate may be augmented by asking to propagate this request to distant servers. The client processor then waits for one or more servers to respond positively (Step **S288**). After all servers respond negatively, or after a timeout period with no positive response, the mechanism repeats selection (Step **S284**) to attempt to identify alternative sources. If any selected source processor responds, its processor ID is the result of this mechanism. Store the processor ID in the source field of the True File registry entry record **140** of the given True Name (Step **S290**).

If the source location of the True Name is a different processor or medium than the destination (Step **S290a**), perform the following steps:

- (i) Look up the True File registry entry record **140** for the corresponding True Name, and add the source location ID to the list of sources for the True Name (Step **S290b**); and
- (ii) If the source is a publishing system, determine the expiration date on the publishing system for the True Name and add that to the list of sources. If the source is not a publishing system, send a message to reserve the True File on the source processor (Step **S290c**).

Source selection in step **S284** may be based on optimizations involving general availability of the source, access time, bandwidth, and transmission cost, and ignoring previously selected processors which did not respond in step **S288**.

8. Make True File Local

This mechanism is used when a True Name is known and a locally accessible copy of the corresponding file or data item is required. This mechanism makes it possible to actually read the data in a True File. The mechanism takes

a True Name and returns when there is a local, accessible copy of the True File in the True File registry 126. This mechanism is described here with reference to the flow chart of FIGS. 17(a) and 17(b).

First, look in the True File registry 126 for a True File entry record 140 for the corresponding True Name (Step S292). If no such entry is found this mechanism fails. If there is already a True File ID for the entry (Step S294), this mechanism's task is complete. If there is a compressed file ID for the entry (Step S296), decompress the file corresponding to the file ID (Step S298) and store the decompressed file ID in the entry (Step S300). This mechanism is then complete.

If there is no True File ID for the entry (Step S294) and there is no compressed file ID for the entry (Step S296), then continue searching for the requested file. At this time it may be necessary to notify the user that the system is searching for the requested file.

If there are one or more source IDs, then select an order in which to attempt to realize the source ID (Step S304). The order may be based on optimizations involving general availability of the source, access time, bandwidth, and transmission cost. For each source in the order chosen, realize the True File from the source location (using the Realize True File from Location primitive mechanism), until the True File is realized (Step S306). If it is realized, continue with step S294. If no known source can realize the True File, use the Locate Remote File primitive mechanism to attempt to find the True File (Step S308). If this succeeds, realize the True File from the identified source location and continue with step S296.

9. Create Scratch File

A scratch copy of a file is required when a file is being created or is about to be modified. The scratch copy is stored in the file system of the underlying operating system. The scratch copy is eventually assimilated when the audit file record entry 146 is processed by the Process Audit File Entry primitive mechanism. This Create Scratch File mechanism requires a local directory extensions table entry record 138. When it succeeds, the local directory extensions table entry record 138 contains the scratch file ID of a scratch file that is not contained in the True File registry 126 and that may be modified. This mechanism is now described with reference to FIGS. 18(a) and 18(b).

First determine whether the scratch file should be a copy of the existing True File (Step S310). If so, continue with step S312. Otherwise, determine whether the local directory extensions table entry record 138 identifies an existing True File (Step S316), and if so, delete the True File using the Delete True File primitive mechanism (Step S318). Then create a new, empty scratch file and store its scratch file ID in the local directory extensions table entry record 138 (step S320). This mechanism is then complete.

If the local directory extensions table entry record 138 identifies a scratch file ID (Step S312), then the entry already has a scratch file, so this mechanism succeeds.

If the local directory extensions table entry record 138 identifies a True File (S316), and there is no True File ID for the True File (S312), then make the True File local using the Make True File Local primitive mechanism (Step S322). If there is still no True File ID, this mechanism fails.

There is now a local True File for this file. If the use count in the corresponding True File registry entry record 140 is one (Step S326), save the True File ID in the scratch file ID of the local directory extensions table entry record 138, and remove the True File registry entry record 140 (Step S328). (This step makes the True File into a scratch file.) This mechanism's task is complete.

Otherwise, if the use count in the corresponding True File registry entry record 140 is not one (in step S326), copy the file with the given True File ID to a new scratch file, using the Read File OS mechanism and store its file ID in the local directory extensions table entry record 138 (Step S330), and reduce the use count for the True File by one. If there is insufficient space to make a copy, this mechanism fails.

10. Freeze Directory

This mechanism freezes a directory in order to calculate its True Name. Since the True Name of a directory is a function of the files within the directory, they must not change during the computation of the True Name of the directory. This mechanism requires the pathname of a directory to freeze. This mechanism is described with reference to FIGS. 19(a) and 19(b).

In step S332, add one to the global freeze lock. Then search the local directory extensions table 124 to find each subordinate data file and directory of the given directory, and freeze each subordinate directory found using the Freeze Directory primitive mechanism (Step S334). Assimilate each unassimilated data file in the directory using the Assimilate Data Item primitive mechanism (Step S336). Then create a data item which begins with a tag or marker (a "magic number") being a unique data item indicating that this data item is a frozen directory (Step S337). Then list the file name and True Name for each file in the current directory (Step S338). Record any additional information required, such as the type, time of last access and modification, and size (Step S340). Next, in step S342, using the Assimilate Data Item primitive mechanism, assimilate the data item created in step S338. The resulting True Name is the True Name of the frozen directory. Finally, subtract one from the global freeze lock (Step S344).

11. Expand Frozen Directory

This mechanism expands a frozen directory in a given location. It requires a given pathname into which to expand the directory, and the True Name of the directory and is described with reference to FIG. 20.

First, in step S346, make the True File with the given True Name local using the Make True File Local primitive mechanism. Then read each directory entry in the local file created in step S346 (Step S348). For each such directory entry, do the following:

Create a full pathname using the given pathname and the file name of the entry (Step S350); and

link the created path to the True Name (Step S352) using the Link Path to True Name primitive mechanism.

12. Delete True File

This mechanism deletes a reference to a True Name. The underlying True File is not removed from the True File registry 126 unless there are no additional references to the file. With reference to FIG. 21, this mechanism is performed as follows:

If the global freeze lock is on, wait until the global freeze lock is turned off (Step S354). This prevents deleting a True File while a directory which might refer to it is being frozen.

Next, find the True File registry entry record 140 given the True Name (Step S356). If the reference count field of the True File registry 126 is greater than zero, subtract one from the reference count field (Step S358). If it is determined (in step S360) that the reference count field of the True File registry entry record 140 is zero, and if there are no dependent systems listed in the True File registry entry record 140, then perform the following steps:

(i) If the True File is a simple data item, then delete the True File, otherwise,

(ii) (the True File is a compound data item) for each True Name in the data item, recursively delete the True File corresponding to the True Name (Step S362).

(iii) Remove the file indicated by the True File ID and compressed file ID from the True File registry 126, and remove the True File registry entry record 140 (Step S364).

13. Process Audit File Entry

This mechanism performs tasks which are required to maintain information in the local directory extensions table 124 and True File registry 126, but which can be delayed while the processor is busy doing more time-critical tasks. Entries 142 in the audit file 132 should be processed at a background priority as long as there are entries to be processed. With reference to FIG. 22, the steps for processing an entry are as follows:

Determine the operation in the entry 142 currently being processed (Step S365). If the operation indicates that a file was created or written (Step S366), then assimilate the file using the Assimilate Data Item primitive mechanism (Step S368), use the New True File primitive mechanism to do additional desired processing (such as cache update, compression, and mirroring) (Step S369), and record the newly computed True Name for the file in the audit file record entry (Step S370).

Otherwise, if the entry being processed indicates that a compound data item or directory was copied (or deleted) (Step S376), then for each component True Name in the compound data item or directory, add (or subtract) one to the use count of the True File registry entry record 140 corresponding to the component True Name (Step S378).

In all cases, for each parent directory of the given file, update the size, time of last access, and time of last modification, according to the operation in the audit record (Step S379).

Note that the audit record is not removed after processing, but is retained for some reasonable period so that it may be used by the Synchronize Directory extended mechanism to allow a disconnected remote processor to update its representation of the local system.

14. Begin Grooming

This mechanism makes it possible to select a set of files for removal and determine the overall amount of space to be recovered. With reference to FIG. 23, first verify that the global grooming lock is currently unlocked (Step S382). Then set the global grooming lock, set the total amount of space freed during grooming to zero and empty the list of files selected for deletion (Step S384). For each True File in the True File registry 126, set the delete count to zero (Step S386).

15. Select For Removal

This grooming mechanism tentatively selects a pathname to allow its corresponding True File to be removed. With reference to FIG. 24, first find the local directory extensions table entry record 138 corresponding to the given pathname (Step S388). Then find the True File registry entry record 140 corresponding to the True File name in the local directory extensions table entry record 138 (Step S390). Add one to the grooming delete count in the True File registry entry record 140 and add the pathname to a list of files selected for deletion (Step S392). If the grooming delete count of the True File registry entry record 140 is equal to the use count of the True File registry entry record 140, and if there are no entries in the dependency list of the True File registry entry record 140, then add the size of the file indicated by the True File ID and or compressed file ID to the total amount of space freed during grooming (Step S394).

16. End Grooming

This grooming mechanism ends the grooming phase and removes all files selected for removal. With reference to

FIG. 25, for each file in the list of files selected for deletion, delete the file (Step S396) and then unlock the global grooming lock (Step S398).

Operating System Mechanisms

The next of the mechanisms provided by the present invention, operating system mechanisms, are now described.

The following operating system mechanisms are described:

1. Open File;
2. Close File;
3. Read File;
4. Write File;
5. Delete File or Directory;
6. Copy File or Directory;
7. Move File or Directory;
8. Get File Status; and
9. Get Files in Directory.

1. Open File

A mechanism to open a file is described with reference to FIGS. 26(a) and 26(b). This mechanism is given as input a pathname and the type of access required for the file (for example, read, write, read/write, create, etc.) and produces either the File ID of the file to be opened or an indication that no file should be opened. The local directory extensions table record 138 and region table record 142 associated with the opened file are associated with the open file for later use in other processing functions which refer to the file, such as read, write, and close.

First, determine whether or not the named file exists locally by examining the local directory extensions table 124 to determine whether there is an entry corresponding to the given pathname (Step S400). If it is determined that the file name does not exist locally, then, using the access type, determine whether or not the file is being created by this opening process (Step S402). If the file is not being created, prohibit the open (Step S404). If the file is being created, create a zero-length scratch file using an entry in local directory extensions table 124 and produce the scratch file ID of this scratch file as the result (Step S406).

If, on the other hand, it is determined in step S400 that the file name does exist locally, then determine the region in which the file is located by searching the region table 128 to find the record 142 with the longest region path which is a prefix of the file pathname (Step S408). This record identifies the region of the specified file.

Next, determine using the access type, whether the file is being opened for writing or whether it is being opened only for reading (Step S410). If the file is being opened for reading only, then, if the file is a scratch file (Step S419), return the scratch File ID of the file (Step S424). Otherwise get the True Name from the local directory extensions table 124 and make a local version of the True File associated with the True Name using the Make True File Local primitive mechanism, and then return the True File ID associated with the True Name (Step S420).

If the file is not being opened for reading only (Step S410), then, if it is determined by inspecting the region table entry record 142 that the file is in a read-only directory (Step S416), then prohibit the opening (Step S422).

If it is determined by inspecting the region table 128 that the file is in a cached region (Step S423), then send a Lock Cache message to the corresponding cache server, and wait for a return message (Step S418). If the return message says the file is already locked, prohibit the opening.

If the access type indicates that the file being modified is being rewritten completely (Step S419), so that the original data will not be required, then Delete the File using the Delete File OS mechanism (Step S421) and perform step S406. Otherwise, make a scratch copy of the file (Step S417) and produce the scratch file ID of the scratch file as the result (Step S424).

2. Close File

This mechanism takes as input the local directory extensions table entry record 138 of an open file and the data maintained for the open file. To close a file, add an entry to the audit file indicating the time and operation (create, read or write). The audit file processing (using the Process Audit File Entry primitive mechanism) will take care of assimilating the file and thereby updating the other records.

3. Read File

To read a file, a program must provide the offset and length of the data to be read, and the location of a buffer into which to copy the data read.

The file to be read from is identified by an open file descriptor which includes a File ID as computed by the Open File operating system mechanism defined above. The File ID may identify either a scratch file or a True File (or True File segment). If the File ID identifies a True File, it may be either a simple or a compound True File. Reading a file is accomplished by the following steps:

In the case where the File ID identifies a scratch file or a simple True File, use the read capabilities of the underlying operating system.

In the case where the File ID identifies a compound file, break the read operation into one or more read operations on component segments as follows:

- A. Identify the segment(s) to be read by dividing the specified file offset and length each by the fixed size of a segment (a system dependent parameter), to determine the segment number and number of segments that must be read.
- B. For each segment number computed above, do the following:
 - i. Read the compound True File index block to determine the True Name of the segment to be read.
 - ii. Use the Realize True File from Location primitive mechanism to make the True File segment available locally. (If that mechanism fails, the Read File mechanism fails).
 - iii. Determine the File ID of the True File specified by the True Name corresponding to this segment.
 - iv. Use the Read File mechanism (recursively) to read from this segment into the corresponding location in the specified buffer.

4. Write File

File writing uses the file ID and data management capabilities of the underlying operating system. File access (Make File Local described above) can be deferred until the first read or write.

5. Delete File or Directory

The process of deleting a file, for a given pathname, is described here with reference to FIGS. 27(a) and 27(b).

First, determine the local directory extensions table entry record 138 and region table entry record 142 for the file (Step S422). If the file has no local directory extensions table entry record 138 or is locked or is in a read-only region, prohibit the deletion.

Identify the corresponding True File given the True Name of the file being deleted using the True File registry 126 (Step S424). If the file has no True Name, (Step S426) then delete the scratch copy of the file based on its scratch file ID

in the local directory extensions table 124 (Step S427), and continue with step S428.

If the file has a True Name and the True File's use count is one (Step S429), then delete the True File (Step S430), and continue with step S428.

If the file has a True Name and the True File's use count is greater than one, reduce its use count by one (Step S431). Then proceed with step S428.

In Step S428, delete the local directory extensions table entry record, and add an entry to the audit file 132 indicating the time and the operation performed (delete).

6. Copy File or Directory

A mechanism is provided to copy a file or directory given a source and destination processor and pathname. The Copy File mechanism does not actually copy the data in the file, only the True Name of the file. This mechanism is performed as follows:

- (A) Given the source path, get the True Name from the path. If this step fails, the mechanism fails.
- (B) Given the True Name and the destination path, link the destination path to the True Name.
- (C) If the source and destination processors have different True File registries, find (or, if necessary, create) an entry for the True Name in the True File registry table 126 of the destination processor. Enter into the source ID field of this new entry the source processor identity.
- (D) Add an entry to the audit file 132 indicating the time and operation performed (copy).

This mechanism addresses capability of the system to avoid copying data from a source location to a destination location when the destination already has the data. In addition, because of the ability to freeze a directory, this mechanism also addresses capability of the system immediately to make a copy of any collection of files, thereby to support an efficient version control mechanisms for groups of files.

7. Move File or Directory

A mechanism is described which moves (or renames) a file from a source path to a destination path. The move operation, like the copy operation, requires no actual transfer of data, and is performed as follows:

- (A) Copy the file from the source path to the destination path.
- (B) If the source path is different from the destination path, delete the source path.

8. Get File Status

This mechanism takes a file pathname and provides information about the pathname. First the local directory extensions table entry record 138 corresponding to the pathname given is found. If no such entry exists, then this mechanism fails, otherwise, gather information about the file and its corresponding True File from the local directory extensions table 124. The information can include any information shown in the data structures, including the size, type, owner, True Name, sources, time of last access, time of last modification, state (local or not, assimilated or not, compressed or not), use count, expiration date, and reservations.

9. Get Files in Directory

This mechanism enumerates the files in a directory. It is used (implicitly) whenever it is necessary to determine whether a file exists (is present) in a directory. For instance, it is implicitly used in the Open File, Delete File, Copy File or Directory, and Move File operating system mechanisms, because the files operated on are referred to by pathnames containing directory names. The mechanism works as follows:

The local directory extensions table **124** is searched for an entry **138** with the given directory pathname. If no such entry is found, or if the entry found is not a directory, then this mechanism fails.

If there is a corresponding True File field in the local directory extensions table record, then it is assumed that the True File represents a frozen directory. The Expand Frozen Directory primitive mechanism is used to expand the existing True File into directory entries in the local directory extensions table.

Finally, the local directory extensions table **124** is again searched, this time to find each directory subordinate to the given directory. The names found are provided as the result.

Remote Mechanisms

The remote mechanisms provided by the present invention are now described. Recall that remote mechanisms are used by the operating system in responding to requests from other processors. These mechanisms enable the capabilities of the present invention in a peer-to-peer network mode of operation.

In a presently preferred embodiment, processors communicate with each other using a remote procedure call (RPC) style interface, running over one of any number of communication protocols such as IPX/SPX or TCP/IP. Each peer processor which provides access to its True File registry **126** or file regions, or which depends on another peer processor, provides a number of mechanisms which can be used by its peers.

The following remote mechanisms are described:

1. Locate True File;
2. Reserve True File;
3. Request True File;
4. Retire True File;
5. Cancel Reservation;
6. Acquire True File;
7. Lock Cache;
8. Update Cache; and
9. Check Expiration Date.

1. Locate True File

This mechanism allows a remote processor to determine whether the local processor contains a copy of a specific True File. The mechanism begins with a True Name and a flag indicating whether to forward requests for this file to other servers. This mechanism is now described with reference to FIG. 28.

First determine if the True File is available locally or if there is some indication of where the True File is located (for example, in the Source IDs field). Look up the requested True Name in the True File registry **126** (Step **S432**).

If a True File registry entry record **140** is not found for this True Name (Step **S434**), and the flag indicates that the request is not to be forwarded (Step **S436**), respond negatively (Step **S438**). That is, respond to the effect that the True File is not available.

One the other hand, if a True File registry entry record **140** is not found (Step **S434**), and the flag indicates that the request for this True File is to be forwarded (Step **S436**), then forward a request for this True File to some other processors in the system (Step **S442**). If the source table for the current processor identifies one or more publishing servers which should have a copy of this True File, then forward the request to each of those publishing servers (Step **S436**).

If a True File registry entry record **140** is found for the required True File (Step **S434**), and if the entry includes a

True File ID or Compressed File ID (Step **S440**), respond positively (Step **S444**). If the entry includes a True File ID then this provides the identity or disk location of the actual physical representation of the file or file segment required. If the entry include a Compressed File ID, then a compressed version of the True File may be stored instead of, or in addition to, an uncompressed version. This field provides the identity of the actual representation of the compressed version of the file.

If the True File registry entry record **140** is found (Step **S434**) but does not include a True File ID (the File ID is absent if the actual file is not currently present at the current location) (Step **S440**), and if the True File registry entry record **140** includes one or more source processors, and if the request can be forwarded, then forward the request for this True File to one or more of the source processors (Step **S444**).

2. Reserve True File

This mechanism allows a remote processor to indicate that it depends on the local processor for access to a specific True File. It takes a True Name as input. This mechanism is described here.

(A) Find the True File registry entry record **140** associated with the given True File. If no entry exists, reply negatively.

(B) If the True File registry entry record **140** does not include a True File ID or compressed File ID, and if the True File registry entry record **140** includes no source IDs for removable storage volumes, then this processor does not have access to a copy of the given file. Reply negatively.

(C) Add the ID of the sending processor to the list of dependent processors for the True File registry entry record **140**. Reply positively, with an indication of whether the reserved True File is on line or off line.

3. Request True File

This mechanism allows a remote processor to request a copy of a True File from the local processor. It requires a True Name and responds positively by sending a True File back to the requesting processor. The mechanism operates as follows:

(A) Find the True File registry entry record **140** associated with the given True Name. If there is no such True File registry entry record **140**, reply negatively.

(B) Make the True File local using the Make True File Local primitive mechanism. If this mechanism fails, the Request True File mechanism also fails.

(C) Send the local True File in either it is uncompressed or compressed form to the requesting remote processor. Note that if the True File is a compound file, the components are not sent.

(D) If the remote file is listed in the dependent process list of the True File registry entry record **140**, remove it.

4. Retire True File

This mechanism allows a remote processor to indicate that it no longer plans to maintain a copy of a given True File. An alternate source of the True File can be specified, if, for instance, the True File is being moved from one server to another. It begins with a True Name, a requesting processor ID, and an optional alternate source. This mechanism operates as follows:

(A) Find a True Name entry in the True File registry **126**. If there is no entry for this True Name, this mechanism's task is complete.

(B) Find the requesting processor on the source list and, if it is there, remove it.

(C) If an alternate source is provided, add it to the source list for the True File registry entry record **140**.

(D) If the source list of the True File registry entry record **140** has no items in it, use the Locate Remote File primitive mechanism to search for another copy of the file. If it fails, raise a serious error.

5. Cancel Reservation

This mechanism allows a remote processor to indicate that it no longer requires access to a True File stored on the local processor. It begins with a True Name and a requesting processor ID and proceeds as follows:

(A) Find the True Name entry in the True File registry **126**. If there is no entry for this True Name, this mechanism's task is complete.

(B) Remove the identity of the requesting processor from the list of dependent processors, if it appears.

(C) If the list of dependent processors becomes zero and the use count is also zero, delete the True File.

6. Acquire True File

This mechanism allows a remote processor to insist that a local processor make a copy of a specified True File. It is used, for example, when a cache client wants to write through a new version of a file. The Acquire True File mechanism begins with a data item and an optional True Name for the data item and proceeds as follows:

(A) Confirm that the requesting processor has the right to require the local processor to acquire data items. If not, send a negative reply.

(B) Make a local copy of the data item transmitted by the remote processor.

(C) Assimilate the data item into the True File registry of the local processor.

(D) If a True Name was provided with the file, the True Name calculation can be avoided, or the mechanism can verify that the file received matches the True Name sent.

(E) Add an entry in the dependent processor list of the true file registry record indicating that the requesting processor depends on this copy of the given True File.

(F) Send a positive reply.

7. Lock Cache

This mechanism allows a remote cache client to lock a local file so that local users or other cache clients cannot change it while the remote processor is using it. The mechanism begins with a pathname and proceeds as follows:

(A) Find the local directory extensions table entry record **138** of the specified pathname. If no such entry exists, reply negatively.

(B) If an local directory extensions table entry record **138** exists and is already locked, reply negatively that the file is already locked.

(C) If an local directory extensions table entry record **138** exists and is not locked, lock the entry. Reply positively.

8. Update Cache

This mechanism allows a remote cache client to unlock a local file and update it with new contents. It begins with a pathname and a True Name. The file corresponding to the True Name must be accessible from the remote processor. This mechanism operates as follows:

Find the local directory extensions table entry record **138** corresponding to the given pathname. Reply negatively if no such entry exists or if the entry is not locked.

Link the given pathname to the given True Name using the Link Path to True Name primitive mechanism.

Unlock the local directory extensions table entry record **138** and return positively.

9. Check Expiration Date

Return current or new expiration date and possible alternative source to caller.

Background Processes and Mechanisms

The background processes and mechanisms provided by the present invention are now described. Recall that background mechanisms are intended to run occasionally and at a low priority to provide automated management capabilities with respect to the present invention.

The following background mechanisms are described:

1. Mirror True File;
2. Groom Region;
3. Check for Expired Links;
4. Verify Region; and
5. Groom Source List.

1. Mirror True File

This mechanism is used to ensure that files are available in alternate locations in mirror groups or archived on archival servers. The mechanism depends on application-specific migration/archival criteria (size, time since last access, number of copies required, number of existing alternative sources) which determine under what conditions a file should be moved. The Mirror True File mechanism operates as follows, using the True File specified, perform the following steps:

(A) Count the number of available locations of the True File by inspecting the source list of the True File registry entry record **140** for the True File. This step determines how many copies of the True File are available in the system.

(B) If the True File meets the specified migration criteria, select a mirror group server to which a copy of the file should be sent. Use the Acquire True File remote mechanism to copy the True File to the selected mirror group server. Add the identity of the selected system to the source list for the True File.

2. Groom Region

This mechanism is used to automatically free up space in a processor by deleting data items that may be available elsewhere. The mechanism depends on application-specific grooming criteria (for instance, a file may be removed if there is an alternate online source for it, it has not been accessed in a given number of days, and it is larger than a given size). This mechanism operates as follows:

Repeat the following steps (i) to (iii) with more aggressive grooming criteria until sufficient space is freed or until all grooming criteria have been exercised. Use grooming information to determine how much space has been freed. Recall that, while grooming is in effect, grooming information includes a table of pathnames selected for deletion, and keeps track of the amount of space that would be freed if all of the files were deleted.

(i) Begin Grooming (using the primitive mechanism).

(ii) For each pathname in the specified region, for the True File corresponding to the pathname, if the True File is present, has at least one alternative source, and meets application specific grooming criteria for the region, select the file for removal (using the primitive mechanism).

(iii) End Grooming (using the primitive mechanism).

If the region is used as a cache, no other processors are dependent on True Files to which it refers, and all such True

Files are mirrored elsewhere. In this case, True Files can be removed with impunity. For a cache region, the grooming criteria would ordinarily eliminate the least recently accessed True Files first. This is best done by sorting the True Files in the region by the most recent access time before performing step (ii) above. The application specific criteria would thus be to select for removal every True File encountered (beginning with the least recently used) until the required amount of free space is reached.

3. Check for Expired Links

This mechanism is used to determine whether dependencies on published files should be refreshed. The following steps describe the operation of this mechanism:

For each pathname in the specified region, for each True File corresponding to the pathname, perform the following step:

If the True File registry entry record **140** corresponding to the True File contains at least one source which is a publishing server, and if the expiration date on the dependency is past or close, then perform the following steps:

- (A) Determine whether the True File registry entry record contains other sources which have not expired.
- (B) Check the True Name expiration of the server. If the expiration date has been extended, or an alternate source is suggested, add the source to the True File registry entry record **140**.
- (C) If no acceptable alternate source was found in steps (A) or (B) above, make a local copy of the True File.
- (D) Remove the expired source.

4. Verify Region

This mechanism can be used to ensure that the data items in the True File registry **126** have not been damaged accidentally or maliciously. The operation of this mechanism is described by the following steps:

- (A) Search the local directory extensions table **124** for each pathname in the specified region and then perform the following steps:
 - (i) Get the True File name corresponding to the pathname;
 - (ii) If the True File registry entry **140** for the True File does not have a True File ID or compressed file ID, ignore it.
 - (iii) Use the Verify True File mechanism (see extended mechanisms below) to confirm that the True File specified is correct.

5. Groom Source List

The source list in a True File entry should be groomed sometimes to ensure there are not too many mirror or archive copies. When a file is deleted or when a region definition or its mirror criteria are changed, it may be necessary to inspect the affected True Files to determine whether there are too many mirror copies. This can be done with the following steps:

For each affected True File,

- (A) Search the local directory extensions table to find each region that refers to the True File.
- (B) Create a set of "required sources", initially empty.
- (C) For each region found,
 - (a) determine the mirroring criteria for that region,
 - (b) determine which sources for the True File satisfy the mirroring criteria, and
 - (c) add these sources to the set of required sources.
- (D) For each source in the True File registry entry, if the source identifies a remote processor (as opposed to removable media), and if the source is not a publisher, and if the source is not in the set of required sources,

then eliminate the source, and use the Cancel Reservation remote mechanism to eliminate the given processor from the list of dependent processors recorded at the remote processor identified by the source.

Extended Mechanisms

The extended mechanisms provided by the present invention are now described. Recall that extended mechanisms run within application programs over the operating system to provide solutions to specific problems and applications.

The following extended mechanisms are described:

1. Inventory Existing Directory;
2. Inventory Removable, Read-only Files;
3. Synchronize Directories;
4. Publish Region;
5. Retire Directory;
6. Realize Directory at Location;
7. Verify True File;
8. Track for Accounting Purposes; and
9. Track for Licensing Purposes.

1. Inventory Existing Directory

This mechanism determines the True Names of files in an existing on-line directory in the underlying operating system. One purpose of this mechanism is to install True Name mechanisms in an existing file system.

An effect of such an installation is to eliminate immediately all duplicate files from the file system being traversed. If several file systems are inventoried in a single True File registry, duplicates across the volumes are also eliminated.

(A) Traverse the underlying file system in the operating system. For each file encountered, excluding directories, perform the following:

- (i) Assimilate the file encountered (using the Assimilate File primitive mechanism). This process computes its True Name and moves its data into the True File registry **126**.
- (ii) Create a pathname consisting of the path to the volume directory and the relative path of the file on the media. Link this path to the computed True Name using the Link Path to True Name primitive mechanism.

2. Inventory Removable, Read-only Files

A system with access to removable, read-only media volumes (such as WORM disks and CD-ROMs) can create a usable inventory of the files on these disks without having to make online copies. These objects can then be used for archival purposes, directory overlays, or other needs. An operator must request that an inventory be created for such a volume.

This mechanism allows for maintaining inventories of the contents of files and data items on removable media, such as diskettes and CD-ROMs, independent of other properties of the files such as name, location, and date of creation.

The mechanism creates an online inventory of the files on one or more removable volumes, such as a floppy disk or CD-ROM, when the data on the volume is represented as a directory. The inventory service uses a True Name to identify each file, providing a way to locate the data independent of its name, date of creation, or location.

The inventory can be used for archival of data (making it possible to avoid archiving data. When that data is already on a separate volume), for grooming (making it possible to delete infrequently accessed files if they can be retrieved from removable volumes), for version control (making it possible to generate a new version of a CD-ROM without having to copy the old version), and for other purposes.

The inventory is made by creating a volume directory in the media inventory in which each file named identifies the data item on the volume being inventoried. Data items are not copied from the removable volume during the inventory process.

An operator must request that an inventory be created for a specific volume. Once created, the volume directory can be frozen or copied like any other directory. Data items from either the physical volume or the volume directory can be accessed using the Open File operating system mechanism which will cause them to be read from the physical volume using the Realize True File from Location primitive mechanism.

To create an inventory the following steps are taken:

(A) A volume directory in the media inventory is created to correspond to the volume being inventoried. Its contextual name identifies the specific volume.

(B) A source table entry **144** for the volume is created in the source table **130**. This entry **144** identifies the physical source volume and the volume directory created in step (A).

(C) The filesystem on the volume is traversed. For each file encountered, excluding directories, the following steps are taken:

(i) The True Name of the file is computed. An entry is created in the True Name registry **124**, including the True Name of the file using the primitive mechanism. The source field of the True Name registry entry **140** identifies the source table entry **144**.

(ii) A pathname is created consisting of the path to the volume directory and the relative path of the file on the media. This path is linked to the computed True Name using Link Path to True Name primitive mechanism.

(D) After all files have been inventoried, the volume directory is frozen. The volume directory serves as a table of contents for the volume. It can be copied using the Copy File or Directory primitive mechanism to create an "overlay" directory which can then be modified, making it possible to edit a virtual copy of a read-only medium.

3. Synchronize Directories

Given two versions of a directory derived from the same starting point, this mechanism creates a new, synchronized version which includes the changes from each. Where a file is changed in both versions, this mechanism provides a user exit for handling the discrepancy. By using True Names, comparisons are instantaneous, and no copies of files are necessary.

This mechanism lets a local processor synchronize a directory to account for changes made at a remote processor. Its purpose is to bring a local copy of a directory up to date after a period of no communication between the local and remote processor. Such a period might occur if the local processor were a mobile processor detached from its server, or if two distant processors were run independently and updated nightly.

An advantage of the described synchronization process is that it does not depend on synchronizing the clocks of the local and remote processors. However, it does require that the local processor track its position in the remote processor's audit file.

This mechanism does not resolve changes made simultaneously to the same file at several sites. If that occurs, an external resolution mechanism such as, for example, operator intervention, is required.

The mechanism takes as input a start time, a local directory pathname, a remote processor name, and a remote directory pathname name, and it operates by the following steps:

(A) Request a copy of the audit file **132** from the remote processor using the Request True File remote mechanism.

(B) For each entry **146** in the audit file **132** after the start time, if the entry indicates a change to a file in the remote directory, perform the following steps:

(i) Compute the pathname of the corresponding file in the local directory. Determine the True Name of the corresponding file.

(ii) If the True Name of the local file is the same as the old True Name in the audit file, or if there is no local file and the audit entry indicates a new file is being created, link the new True Name in the audit file to the local pathname using the Link Path to True Name primitive mechanism.

(iii) Otherwise, note that there is a problem with the synchronization by sending a message to the operator or to a problem resolution program, indicating the local pathname, remote pathname, remote processor, and time of change.

(C) After synchronization is complete, record the time of the final change. This time is to be used as the new start time the next time this directory is synchronized with the same remote processor.

4. Publish Region

The publish region mechanism allows a processor to offer the files in a region to any client processors for a limited period of time.

The purpose of the service is to eliminate any need for client processors to make reservations with the publishing processor. This in turn makes it possible for the publishing processor to service a much larger number of clients.

When a region is published, an expiration date is defined for all files in the region, and is propagated into the publishing system's True File registry entry record **140** for each file.

When a remote file is copied, for instance using the Copy File operating system mechanism, the expiration date is copied into the source field of the client's True File registry entry record **140**. When the source is a publishing system, no dependency need be created.

The client processor must occasionally and in background, check for expired links, to make sure it still has access to these files. This is described in the background mechanism Check for Expired Links.

5. Retire Directory

This mechanism makes it possible to eliminate safely the True Files in a directory, or at least dependencies on them, after ensuring that any client processors depending on those files remove their dependencies. The files in the directory are not actually deleted by this process. The directory can be deleted with the Delete File operating system mechanism.

The mechanism takes the pathname of a given directory, and optionally, the identification of a preferred alternate source processor for clients to use. The mechanism performs the following steps:

(A) Traverse the directory. For each file in the directory, perform the following steps:

(i) Get the True Name of the file from its path and find the True File registry entry **140** associated with the True Name.

(ii) Determine an alternate source for the True File. If the source IDs field of the TFR entry includes the preferred alternate source, that is the alternate source. If it does not, but includes some other source, that is the alternate source. If it contains no alternate sources, there is no alternate source.

31

- (iii) For each dependent processor in the True File registry entry **140**, ask that processor to retire the True File, specifying an alternate source if one was determined, using the remote mechanism.

6. Realize Directory at Location

This mechanism allows the user or operating system to force copies of files from some source location to the True File registry **126** at a given location. The purpose of the mechanism is to ensure that files are accessible in the event the source location becomes inaccessible. This can happen for instance if the source or given location are on mobile computers, or are on removable media, or if the network connection to the source is expected to become unavailable, or if the source is being retired.

This mechanism is provided in the following steps for each file in the given directory, with the exception of subdirectories:

- (A) Get the local directory extensions table entry record **138** given the pathname of the file. Get the True Name of the local directory extensions table entry record **138**. This service assimilates the file if it has not already been assimilated.
- (B) Realize the corresponding True File at the given location. This service causes it to be copied to the given location from a remote system or removable media.

7. Verify True File

This mechanism is used to verify that the data item in a True File registry **126** is indeed the correct data item given its True Name. Its purpose is to guard against device errors, malicious changes, or other problems.

If an error is found, the system has the ability to "heal" itself by finding another source for the True File with the given name. It may also be desirable to verify that the error has not propagated to other systems, and to log the problem or indicate it to the computer operator. These details are not described here.

To verify a data item that is not in a True File registry **126**, use the Calculate True Name primitive mechanism described above.

The basic mechanism begins with a True Name, and operates in the following steps:

- (A) Find the True File registry entry record **140** corresponding to the given True Name.
- (B) If there is a True File ID for the True File registry entry record **140** then use it. Otherwise, indicate that no file exists to verify.
- (C) Calculate the True Name of the data item given the file ID of the data item.
- (D) Confirm that the calculated True Name is equal to the given True Name.
- (E) If the True Names are not equal, there is an error in the True File registry **126**. Remove the True File ID from the True File registry entry record **140** and place it somewhere else. Indicate that the True File registry entry record **140** contained an error.

8. Track for Accounting Purposes

This mechanism provides a way to know reliably which files have been stored on a system or transmitted from one system to another. The mechanism can be used as a basis for a value-based accounting system in which charges are based on the identity of the data stored or transmitted, rather than simply on the number of bits.

This mechanism allows the system to track possession of specific data items according to content by owner, independent of the name, date, or other properties of the data item, and tracks the uses of specific data items and files by content

32

for accounting purposes. True names make it possible to identify each file briefly yet uniquely for this purpose.

Tracking the identities of files requires maintaining an accounting log **134** and processing it for accounting or billing purposes. The mechanism operates in the following steps:

- (A) Note every time a file is created or deleted, for instance by monitoring audit entries in the Process Audit File Entry primitive mechanism. When such an event is encountered, create an entry **148** in the accounting log **134** that Shows the responsible party and the identity of the file created or deleted.
- (B) Every time a file is transmitted, for instance when a file is copied with a Request True File remote mechanism or an Acquire True File remote mechanism, create an entry in the accounting log **134** that shows the responsible party, the identity of the file, and the source and destination processors.
- (C) Occasionally run an accounting program to process the accounting log **134**, distributing the events to the account records of each responsible party. The account records can eventually be summarized for billing purposes.

9. Track for Licensing Purposes

This mechanism ensures that licensed files are not used by unauthorized parties. The True Name provides a safe way to identify licensed material. This service allows proof of possession of specific files according to their contents without disclosing their contents.

Enforcing use of valid licenses can be active (for example, by refusing to provide access to a file without authorization) or passive (for example, by creating a report of users who do not have proper authorization).

One possible way to perform license validation is to perform occasional audits of employee systems. The service described herein relies on True Names to support such an audit, as in the following steps:

- (A) For each licensed product, record in the license table **136** the True Name of key files in the product (that is, files which are required in order to use the product, and which do not occur in other products) Typically, for a software product, this would include the main executable image and perhaps other major files such as clip-art, scripts, or online help. Also record the identity of each system which is authorized to have a copy of the file.
- (B) occasionally, compare the contents of each user processor against the license table **136**. For each True Name in the license table do the following:
- (i) Unless the user processor is authorized to have a copy of the file, confirm that the user processor does not have a copy of the file using the Locate True File mechanism.
- (ii) If the user processor is found to have a file that it is not authorized to have, record the user processor and True Name in a license violation table.

The System in Operation

Given the mechanisms described above, the operation of a typical DP system employing these mechanisms is now described in order to demonstrate how the present invention meets its requirements and capabilities.

In operation, data items (for example, files, database records, messages, data segments, data blocks, directories, instances of object classes, and the like) in a DP system employing the present invention are identified by substan-

tially unique identifiers (True Names), the identifiers depending on all of the data in the data items and only on the data in the data items. The primitive mechanisms Calculate True Name and Assimilate Data Item support this property. For any given data item, using the Calculate True Name primitive mechanism, a substantially unique identifier or True Name for that data item can be determined.

Further, in operation of a DP system incorporating the present invention, multiple copies of data items are avoided (unless they are required for some reason such as backups or mirror copies in a fault-tolerant system). Multiple copies of data items are avoided even when multiple names refer to the same data item. The primitive mechanisms Assimilate Data Items and New True File support this property. Using the Assimilate Data Item primitive mechanism, if a data item already exists in the system, as indicated by an entry in the True File registry 126, this existence will be discovered by this mechanism, and the duplicate data item (the new data item) will be eliminated (or not added). Thus, for example, if a data file is being copied onto a system from a floppy disk, if, based on the True Name of the data file, it is determined that the data file already exists in the system (by the same or some other name), then the duplicate copy will not be installed. If the data item was being installed on the system by some name other than its current name, then, using the Link Path to True Name primitive mechanism, the other (or new) name can be linked to the already existing data item.

In general, the mechanisms of the present invention operate in such a way as to avoid recreating an actual data item at a location when a copy of that data item is already present at that location. In the case of a copy from a floppy disk, the data item (file) may have to be copied (into a scratch file) before it can be determined that it is a duplicate. This is because only one processor is involved. On the other hand, in a multiprocessor environment or DP system, each processor has a record of the True Names of the data items on that processor. When a data item is to be copied to another location (another processor) in the DP system, all that is necessary is to examine the True Name of the data item prior to the copying. If a data item with the same True Name already exists at the destination location (processor), then there is no need to copy the data item. Note that if a data item which already exists locally at a destination location is still copied to the destination location (for example, because the remote system did not have a True Name for the data item or because it arrives as a stream of un-named data), the Assimilate Data Item primitive mechanism will prevent multiple copies of the data item from being created.

Since the True Name of a large data item (a compound data item) is derived from and based on the True Names of components of the data item, copying of an entire data item can be avoided. Since some (or all) of the components of a large data item may already be present at a destination location, only those components which are not present there need be copied. This property derives from the manner in which True Names are determined.

When a file is copied by the Copy File or Directory operating system mechanism, only the True Name of the file is actually replicated.

When a file is opened (using the open File operating system mechanism), it uses the Make True File Local primitive mechanism (either directly or indirectly through the Create Scratch File primitive mechanism) to create a local copy of the file. The Open File operating system mechanism uses the Make True File Local primitive

mechanism, which uses the Realize True File from Location primitive mechanism, which, in turn uses the Request True File remote mechanism.

The Request True File remote mechanism copies only a single data item from one processor to another. If the data item is a compound file, its component segments are not copied, only the indirect block is copied. The segments are copied only when they are read (or otherwise needed).

The Read File operating system mechanism actually reads data. The Read File mechanism is aware of compound files and indirect blocks, and it uses the Realize True File from Location primitive mechanism to make sure that component segments are locally available, and then uses the operating system file mechanisms to read data from the local file.

Thus, when a compound file is copied from a remote system, only its True Name is copied. When it is opened, only its indirect block is copied. When the corresponding file is read, the required component segments are realized and therefore copied.

In operation data items can be accessed by reference to their identities (True Names) independent of their present location. The actual data item or True File corresponding to a given data identifier or True Name may reside anywhere in the system (that is, locally, remotely, offline, etc). If a required True File is present locally, then the data in the file can be accessed. If the data item is not present locally, there are a number of ways in which it can be obtained from wherever it is present. Using the source IDs field of the True File registry table, the location(s) of copies of the True File corresponding to a given True Name can be determined. The Realize True File from Location primitive mechanism tries to make a local copy of a True File, given its True Name and the name of a source location (processor or media) that may contain the True File. If, on the other hand, for some reason it is not known where there is a copy of the True File, or if the processors identified in the source IDs field do not respond with the required True File, the processor requiring the data item can make a general request for the data item using the Request True File remote mechanism from all processors in the system that it can contact.

As a result, the system provides transparent access to any data item by reference to its data identity, and independent of its present location.

In operation, data items in the system can be verified and have their integrity checked. This is from the manner in which True Names are determined. This can be used for security purposes, for instance, to check for viruses and to verify that data retrieved from another location is the desired and requested data. For example, the system might store the True Names of all executable applications on the system and then periodically redetermine the True Names of each of these applications to ensure that they match the stored True Names. Any change in a True Name potentially signals corruption in the system and can be further investigated. The Verify Region background mechanism and the Verify True File extended mechanisms provide direct support for this mode of operation. The Verify Region mechanism is used to ensure that the data items in the True File registry have not been damaged accidentally or maliciously. The Verify True File mechanism verifies that a data item in a True File registry is indeed the correct data item given its True Name.

Once a processor has determined where (that is, at which other processor or location) a copy of a data item is in the DP system, that processor might need that other processor or location to keep a copy of that data item. For example, a processor might want to delete local copies of data items to

make space available locally while knowing that it can rely on retrieving the data from somewhere else when needed. To this end the system allows a processor to Reserve (and cancel the reservation of) True Files at remote locations (using the remote mechanism). In this way the remote locations are put on notice that another location is relying on the presence of the True File at their location.

A DP system employing the present invention can be made into a fault-tolerant system by providing a certain amount of redundancy of data items at multiple locations in the system. Using the Acquire True File and Reserve True File remote mechanisms, a particular processor can implement its own form of fault-tolerance by copying data items to other processors and then reserving them there. However, the system also provides the Mirror True File background mechanism to mirror (make copies) of the True File available elsewhere in the system. Any degree of redundancy (limited by the number of processors or locations in the system) can be implemented. As a result, this invention maintains a desired degree or level of redundancy in a network of processors, to protect against failure of any particular processor by ensuring that multiple copies of data items exist at different locations.

The data structures used to implement various features and mechanisms of this invention store a variety of useful information which can be used, in conjunction with the various mechanisms, to implement storage schemes and policies in a DP system employing the invention. For example, the size, age and location of a data item (or of groups of data items) is provided. This information can be used to decide how the data items should be treated. For example, a processor may implement a policy of deleting local copies of all data items over a certain age if other copies of those data items are present elsewhere in the system. The age (or variations on the age) can be determined using the time of last access or modification in the local directory extensions table, and the presence of other copies of the data item can be determined either from the Safe Flag or the source IDs, or by checking which other processors in the system have copies of the data item and then reserving at least one of those copies.

In operation, the system can keep track of data items regardless of how those items are named by users (or regardless of whether the data items even have names). The system can also track data items that have different names (in different or the same location) as well as different data items that have the same name. Since a data item is identified by the data in the item, without regard for the context of the data, the problems of inconsistent naming in a DP system are overcome.

In operation, the system can publish data items, allowing other, possibly anonymous, systems in a network to gain access to the data items and to rely on the availability of these data items. True Names are globally unique identifiers which can be published simply by copying them. For example, a user might create a textual representation of a file on system A with True Name N (for instance as a hexadecimal string), and post it on a computer bulletin board. Another user on system B could create a directory entry F for this True Name N by using the Link Path to True Name primitive mechanism. (Alternatively, an application could be developed which hides the True Name from the users, but provides the same public transfer service.)

When a program on system B attempts to open pathname F linked to True Name N, the Locate Remote File primitive mechanism would be used, and would use the Locate True

File remote mechanism to search for True Name N on one or more remote processors, such as system A. If system B has access to system A, it would be able to realize the True File (using the Realize True File from Location primitive mechanism) and use it locally. Alternatively, system B could find True Name N by accessing any publicly available True Name server, if the server could eventually forward the request to system A.

Clients of a local server can indicate that they depend on a given True File (using the Reserve True File remote mechanism) so that the True File is not deleted from the server registry as long as some client requires access to it. (The Retire True File remote mechanism is used to indicate that a client no longer needs a given True File.)

A publishing server, on the other hand, may want to provide access to many clients, and possibly anonymous ones, without incurring the overhead of tracking dependencies for each client. Therefore, a public server can provide expiration dates for True Files in its registry. This allows client systems to safely maintain references to a True File on the public server. The Check For Expired Links background mechanism allows the client of a publishing server to occasionally confirm that its dependencies on the publishing server are safe.

In a variation of this aspect of the invention, a processor that is newly connected (or reconnected after some absence) to the system can obtain a current version of all (or of needed) data in the system by requesting it from a server processor. Any such processor can send a request to update or resynchronize all of its directories (starting at a root directory), simply by using the Synchronize Directories extended mechanism on the needed directories.

Using the accounting log or some other user provided mechanism, a user can prove the existence of certain data items at certain times. By publishing (in a public place) a list of all True Names in the system on a given day (or at some given time), a user can later refer back to that list to show that a particular data item was present in the system at the time that list was published. Such a mechanism is useful in tracking, for example, laboratory notebooks or the like to prove dates of conception of inventions. Such a mechanism also permits proof of possession of a data item at a particular date and time.

The accounting log file can also track the use of specific data items and files by content for accounting purposes. For instance, an information utility company can determine the data identities of data items that are stored and transmitted through its computer systems, and use these identities to provide bills to its customers based on the identities of the data items being transmitted (as defined by the substantially unique identifier). The assignment of prices for storing and transmitting specific True Files would be made by the information utility and/or its data suppliers; this information would be joined periodically with the information in the accounting log file to produce customer statements.

Backing up data items in a DP system employing the present invention can be done based on the True Names of the data items. By tracking backups using True Names, duplication in the backups is prevented. In operation, the system maintains a backup record of data identifiers of data items already backed up, and invokes the Copy File or Directory operating system mechanism to copy only those data items whose data identifiers are not recorded in the backup record. Once a data item has been backed up, it can be restored by retrieving it from its backup location, based on the identifier of the data item. Using the backup record

produced by the backup to identify the data item, the data item can be obtained using, for example, the Make True File Local primitive mechanism.

In operation, the system can be used to cache data items from a server, so that only the most recently accessed data items need be retained. To operate in this way, a cache client is configured to have a local registry (its cache) with a remote Local Directory Extensions table (from the cache server). Whenever a file is opened (or read), the Local Directory Extensions table is used to identify the True Name, and the Make True File Local primitive mechanism inspects the local registry. When the local registry already has a copy, the file is already cached. Otherwise, the Locate True File remote mechanism is used to get a copy of the file. This mechanism consults the cache server and uses the Request True File remote mechanism to make a local copy, effectively loading the cache.

The Groom Cache background mechanism flushes the cache, removing the least-recently-used files from the cache client's True File registry. While a file is being modified on a cache client, the Lock Cache and Update Cache remote mechanisms prevent other clients from trying to modify the same file.

In operation, when the system is being used to cache data items, the problems of maintaining cache consistency are avoided.

To access a cache and to fill it from its server, a key is required to identify the data item desired. Ordinarily, the key is a name or address (in this case, it would be the pathname of a file). If the data associated with such a key is changed, the client's cache becomes inconsistent; when the cache client refers to that name, it will retrieve the wrong data. In order to maintain cache consistency it is necessary to notify every client immediately whenever a change occurs on the server.

By using an embodiment of the present invention, the cache key uniquely identifies the data it represents. When the data associated with a name changes, the key itself changes. Thus, when a cache client wishes to access the modified data associated with a given file name, it will use a new key (the True Name of the new file) rather than the key to the old file contents in its cache. The client will always request the correct data, and the old data in its cache will be eventually aged and flushed by the Groom Cache background mechanism.

Because it is not necessary to immediately notify clients when changes on the cache server occur, the present invention makes it possible for a single server to support a much larger number of clients than is otherwise possible.

In operation, the system automatically archives data items as they are created or modified. After a file is created or modified, the Close File operating system mechanism creates an audit file record, which is eventually processed by the Process Audit File Entry primitive mechanism. This mechanism uses the New True File primitive mechanism for any file which is newly created, which in turn uses the Mirror True File background mechanism if the True File is in a mirrored or archived region. This mechanism causes one or more copies of the new file to be made on remote processors.

In operation, the system can efficiently record and preserve any collection of data items. The Freeze Directory primitive mechanism creates a True File which identifies all of the files in the directory and its subordinates. Because this True File includes the True Names of its constituents, it represents the exact contents of the directory tree at the time

it was frozen. The frozen directory can be copied with its components preserved.

The Acquire True File remote mechanism (used in mirroring and archiving) preserves the directory tree structure by ensuring that all of the component segments and True Files in a compound data item are actually copied to a remote system. Of course, no transfer is necessary for data items already in the registry of the remote system.

In operation, the system can efficiently make a copy of any collection of data items, to support a version control mechanism for groups of the data items.

The Freeze Directory primitive mechanism is used to create a collection of data items. The constituent files and segments referred to by the frozen directory are maintained in the registry, without any need to make copies of the constituents each time the directory is frozen.

Whenever a pathname is traversed, the Get Files in Directory operating system mechanism is used, and when it encounters a frozen directory, it uses the Expand Frozen Directory primitive mechanism.

A frozen directory can be copied from one pathname to another efficiently, merely by copying its True Name. The Copy File operating system mechanism is used to copy a frozen directory.

Thus it is possible to efficiently create copies of different versions of a directory, thereby creating a record of its history (hence a version control system).

In operation, the system can maintain a local inventory of all the data items located on a given removable medium, such as a diskette or CD-ROM. The inventory is independent of other properties of the data items such as their name, location, and date of creation.

The Inventory Existing Directory extended mechanism provides a way to create True File Registry entries for all of the files in a directory. One use of this inventory is as a way to pre-load a True File registry with backup record information. Those files in the registry (such as previously installed software) which are on the volumes inventoried need not be backed up onto other volumes.

The Inventory Removable, Read-only Files extended mechanism not only determines the True Names for the files on the medium, but also records directory entries for each file in a frozen directory structure. By copying and modifying this directory, it is possible to create an on line patch, or small modification of an existing read-only file. For example, it is possible to create an online representation of a modified CD-ROM, such that the unmodified files are actually on the CD-ROM, and only the modified files are online.

In operation, the system tracks possession of specific data items according to content by owner, independent of the name, date, or other properties of the data item, and tracks the uses of specific data items and files by content for accounting purposes. Using the Track for Accounting Purposes extended mechanism provides a way to know reliably which files have been stored on a system or transmitted from one system to another.

True Names in Relational and Object-Oriented Databases

Although the preferred embodiment of this invention has been presented in the context of a file system, the invention of True Names would be equally valuable in a relational or object-oriented database. A relational or object-oriented database system using True Names would have similar

benefits to those of the file system employing the invention. For instance, such a database would permit efficient elimination of duplicate records, support a cache for records, simplify the process of maintaining cache consistency, provide location-independent access to records, maintain archives and histories of records, and synchronize with distant or disconnected systems or databases.

The mechanisms described above can be easily modified to serve in such a database environment. The True Name registry would be used as a repository of database records. All references to records would be via the True Name of the record. (The Local Directory Extensions table is an example of a primary index that uses the True Name as the unique identifier of the desired records.)

In such a database, the operations of inserting, updating, and deleting records would be implemented by first assimilating records into the registry, and then updating a primary key index to map the key of the record to its contents by using the True Name as a pointer to the contents.

The mechanisms described in the preferred embodiment, or similar mechanisms, would be employed in such a system. These mechanisms could include, for example, the mechanisms for calculating true names, assimilating, locating, realizing, deleting, copying, and moving True Files, for mirroring True Files, for maintaining a cache of True Files, for grooming True Files, and other mechanisms based on the use of substantially unique identifiers.

While the invention has been described in connection with what is presently considered to be the most practical and preferred embodiments, it is to be understood that the invention is not to be limited to the disclosed embodiment, but on the contrary, is intended to cover various modifications and equivalent arrangements included within the spirit and scope of the appended claims.

What is claimed is:

1. In a system in which a set of data files are distributed across a network of servers, at least some of the data files being cached versions of data files from a source server, wherein the source server is distinct from the servers in the network, a content delivery method comprising:

determining a data identifier for a particular data file on the source server, the data identifier being determined using a given function of the data, wherein said data used by the given function to determine the data identifier comprises the contents of the particular data file; and

responsive to a request for the particular data file, the request including at least the data identifier of the particular data file, providing the particular data file from a given one of the servers of the network of servers, said providing being based on the data identifier of the requested data item.

2. A method as in claim 1 wherein the given function is a message digest function or a hash function.

3. A method as in claim 2 wherein the given function is selected from the functions: MD4, MD5, and SHA.

4. A method as in claim 1 wherein the given function randomly distributes its outputs.

5. A method as in claim 1 wherein, for a particular data file, the given function produces a substantially unique value based on the data comprising the data file.

6. A method as in claim 1 wherein a data file may comprise a file, a portion of a file, a page in memory, a digital message, a digital image, a video signal or an audio signal.

7. A method as in claim 1

wherein certain processors in the network communicate with each other using a TCP/IP communication protocol.

8. A method as in claim 1 wherein said data identifier for said particular data file, as determined using said given function, will change when the particular data file is modified.

9. In a system in which a set of data files are distributed across a network of servers, some of the data files being cached from a source server distinct from the servers in the network, a content delivery method comprising:

determining a data identifier for a particular data file on the source server, the data identifier being determined using a given function of the data, wherein said data used by the given function to determine the data identifier comprises the contents of the particular data file; and

responsive to a request for the particular data file, the request including at least the data identifier of the particular data file, causing a copy of the particular data file to be provided from a given one of the servers of the network of servers.

10. A content delivery method, comprising:

distributing a set of data files across a network of servers; determining a data identifier for a particular data file, the data identifier being determined using a given function of the data, wherein said data used by the given function to determine the data identifier comprises the contents of the particular data file; and

in response to a request for the particular data file, the request including at least the data identifier of the particular data file, providing the particular data file from a given one of the servers of the network of servers, said providing being based on the data identifier of the particular data file.

11. A method as in claim 10 further comprising:

determining whether the data identifier corresponds to a data identifier of any data file present on the given server.

12. A method as in claim 11 further comprising:

based on said determining, if the data identifier does not correspond to a data file present on the given server, locating the particular data file from another server.

13. A method as in claim 12 further comprising:

obtaining, on the given server, a local copy of the particular data file, from the other server.

14. A method as in claim 10 wherein at least some of the data files distributed across the network of servers are cached versions of data files from another server, distinct from the network of servers.

15. A method as in claim 10 further comprising:

resolving the request for the particular data file based on a measure of availability of at least one of the servers.

16. A method as in claim 15 wherein the measure of availability is based on one or more of:

(a) a measurement of bandwidth to the server;

(b) a measurement of a cost of a connection to the server, and

(c) a measurement of a reliability of a connection to the server.

17. A method as in claim 10 wherein the data file is a compound data file made up of various component data files, the method further comprising:

for each component data file of at least some of the component data files:

(a) determining a data identifier for the component data file, the data identifier for the component file determined using the given function of the data, wherein

41

said data used by the given function to determine the data identifier comprises the contents of the component data file; and

(b) providing the component data file from a given one of the servers of the network of servers.

18. A content delivery method, comprising:

distributing a set of data files across a network of servers; for a particular data file having a particular name specifying a location in the network at which the data file may be located, determining another name for the particular data file, the other name including a data identifier determined using a given function of the data, where said data used by the given function comprises the contents of the particular data file; and

in response to a request for the particular data file, the request including the other name of the particular data file, providing the particular data file from a given one of the servers of the network of servers.

19. A method as in claim 18 wherein at least some of the data files are cached versions of data files from another server which is distinct from the network of servers.

20. A method as in claim 18 further comprising:

resolving the request for the particular data file based on a measure of availability of at least one of the servers.

21. A method as in claim 20 wherein the measure of availability is based on one or more of:

- (a) a measurement of bandwidth to the server;
- (b) a measurement of a cost of a connection to the server, and
- (c) a measurement of a reliability of a connection to the server.

22. A method as in claim 18 wherein the particular data file is a compound data file comprising various component data files, the method further comprising:

for at least one component data file:

- (a) determining a data identifier for the component data file, the data identifier determined using a given function of the data, wherein said data used by the given function comprises the contents of the component data file; and
- (b) providing the component data file from a given one of the servers of the network of servers.

23. A content delivery method, comprising:

distributing a set of data files across a network of servers, at least some of the data files being cached versions of data files from another server, distinct from the network of servers;

determining a data identifier for a particular data file, the data identifier determined using a given function of the data, wherein said data used by the given function comprises the contents of the particular data file; and

in response to a request for the particular data file, the request including at least the data identifier of the particular data file, providing the particular data file from a given one of the servers of the network of servers.

24. A content delivery method, comprising:

causing a set of data files to be distributed across a network of servers, at least some of the data files being cached versions of data files from another server distinct from the network of servers;

determining a data identifier for a particular data file, the data identifier determined using a given function of the data, wherein said data used by the given function comprises the contents of the particular data file; and

42

in response to a request for the particular data file, the request including at least the data identifier of the particular data file, causing the particular data file to be provided from a given one of the servers of the network of servers.

25. A content delivery method, comprising:

distributing a set of data files across a network of servers, the network of servers being organized into a set of regions;

determining a data identifier for a particular data file, the data identifier determined using a given function of the data, wherein said data used by the given function comprises the contents of the data file;

in response to a client request for the particular data file, the request including at least the data identifier of the particular data file, providing the client with the particular data file from a given one of the servers of the network of servers within the region.

26. In a system in which a set of data files are distributed across a network of servers, at least some of the data files being cached versions of data files from a source server distinct from the network of servers, a content delivery method comprising:

responsive to a request for a particular data file, the request including at least a data identifier of the particular data file, wherein the data identifier is determined by applying a message digest function MD5 to the data, wherein said data used by the MD5 function to determine the data identifier is the contents of the particular data file, providing the particular data file from a given one of the servers of the network of servers,

wherein a data file may be a file, a portion of a file, a page in memory, a digital message, a digital image, a video signal or an audio signal.

27. A content delivery method, comprising:

distributing a set of data files across a network of servers, at least some of the data files being cached versions of data files from another server distinct from the network of servers;

determining a data identifier for a particular data file, the data identifier determined using a given function of the data, wherein said data used by the given function comprises the contents of the particular data file, and wherein the given function randomly distributes its outputs; and

in response to a request for the particular data file, the request including at least the data identifier of the particular data file, providing the particular data file from a given one of the servers of the network of servers, said providing being based on the data identifier of the particular data item.

28. A method as in claim 27 further comprising:

maintaining accounting information relating to the data files; and

using the accounting information as a basis for a value-based accounting system in which charges are based on an identity of the data files.

29. A method as in claim 28 wherein the maintaining of accounting information includes at least some of:

- (a) tracking which data files have been stored on a system; and
- (b) tracking which data files have been transmitted from a server.

30. A method as in claim 28 further comprising:

43

ensuring that a data file is not used by an unauthorized party.

31. A content delivery method, comprising:

distributing a set of data files across a network of servers; determining an MD5 hash of the contents of a particular data file; and

in response to a request for the particular data file, the request including at least the MD5 hash of the particular data file, providing the particular data file from a given one of the servers of the network of servers, said providing being based on the MD5 hash of the particular data file.

32. A method as in claim 31 further comprising:

resolving the request for the particular data file based on a measure of availability of at least one of the servers.

33. A method as in claim 32 wherein the measure of availability for a server is based on one or more of:

- (a) a measurement of bandwidth to the server;
- (b) a measurement of a cost of a connection to the server, and
- (c) a measurement of reliability of a connection to the server.

34. A content delivery method, comprising:

distributing a set of data files across a network of servers; for a particular data file having a particular data identifier specifying a location in the network at which the particular data file may be located, determining another data identifier for the particular data file, the other data identifier including a data identifier determined using a message digest function of the contents of the particular data file;

in response to a request for the particular data file, the request including the other data identifier of the particular data file, providing the particular data file from a given one of the servers of the network of servers, said providing being based on the other data identifier which was determined using the message digest function.

35. A content delivery method, comprising:

distributing a set of data files across a network of servers, at least some of the data files being cached versions of data files from another server, said other server being distinct from the network of servers;

determining a data identifier for a particular data file, the data identifier including a hash of the contents of the particular data file; and

in response to a request for the particular data file, the request including at least the data identifier of the particular data file, providing the particular data file from a given one of the servers of the network of servers.

36. A method of delivering a data file in a network comprising a plurality of processors, some of the processors being servers and some of the processors being clients, the method comprising:

storing the data file is on a first server in the network and storing copies of the data file on a set of servers in the network distinct from the first server; and

responsive to a client request for the data file, the request including a hash of the contents of the data file, causing the data file to be provided to the client.

37. A method as in claim 36 wherein the data file has a contextual name comprising a pathname including a processor name and a file name, the method further comprising:

44

associating the contextual name of the data file with the hash of the contents of the data file.

38. A method of delivering a data file in a network comprising a plurality of processors, some of the processors being servers and some of the processors being clients, the method comprising:

storing the data file is on a first server and storing copies of the data file on a set of servers distinct from the first server; and

responsive to a client request for the data file, the request including a value determined as a given function of the contents of the data file, providing the data file to the client.

39. A method as in claim 38 wherein the data file has a contextual name comprising a pathname including a processor name and a file name, the method further comprising: associating the contextual name of the data file with the value determined as the given function of the data in the data file.

40. A method of delivering a data file in a network comprising a plurality of processors, some of the processors being servers and some of the processors being clients, wherein some processors in the network communicate with each other using a TCP/IP communication protocol, wherein a key is required to identify a data file on the network and wherein ordinarily the key is a name or address for the data file, the method comprising:

storing some data files on a first server in the network and storing copies of some of the data files on a set of cache servers distinct from the first server;

determining a different cache key from the ordinarily used cache key, the different cache key being a function of the contents of the data it represents; and

responsive to a client request for the data file, the request including the different cache key for the data file, providing the data file to the client.

41. A method as in claim 40 wherein the function is a message digest function or a hash function.

42. A method as in claim 41 wherein the function is selected from the functions: MD4, MD5, and SHA.

43. A method as in claim 40 wherein the function randomly distributes its outputs.

44. A framework operative in a computer network in which users of client processors connect to a content server, the framework comprising:

a set of content servers, distinct from the content provider server, for hosting at least some of the data files that are normally hosted by the content provider server;

a mechanism constructed and adapted to determine an identifier for a data file as a given function of the contents of a data file in the network;

wherein, in response to requests for a data file, generated by one of the client machines the request including an identifier based on the given function of the contents of the particular data file, the particular data file is served from one of the content servers.

45. A framework as in claim 44 wherein the given function is a message digest function or a hash function.

46. A framework as in claim 45 wherein the given function is selected from the functions: MD4, MD5, and SHA.

47. A framework as in claim 44 wherein the given function randomly distributes its outputs.

48. A framework as in claim 44 wherein processors in the network communicate with each other using a TCP/IP communication protocol.

49. A framework as in claim 44 wherein the data file has a contextual name, the framework further comprising:

a mechanism constructed and adapted to associate the contextual name of the data file with the identifier for the data file.

50. A framework as in claim 49 wherein the contextual name of the data file comprises a pathname including a processor name and a file name.

51. A framework as in claim 44 wherein a data file may be a file, a portion of a file, a page in memory, a digital message, a digital image, a video signal or an audio signal.

52. In a network comprising a plurality of processors, some of the processors functioning as servers and some of the processors functioning as clients, wherein some processors in the network communicate with each other using a TCP/IP communication protocol, wherein a key is required to identify a data file on the network and wherein ordinarily the key is a name or address for the data file, a method of delivering a data file:

storing some data files on a first server in the network and storing copies of some of the data files from the first server on a set of cache servers distinct from the first server;

for a particular data file, determining a different cache key from the ordinarily used cache key for the data file, the different cache key being determined using a message digest function MD5 of the data, wherein said data used by the MD5 function comprises the contents of the particular data file; and

responsive to a client request for the particular data file, the request including the different cache key for the data file, causing the particular data file to be provided to the client,

wherein the data file may be a file, a portion of a file, a page in memory, a digital message, a digital image, a video signal or an audio signal.

53. A framework operative in a computer network in which users of client processors connect to a content server, wherein processors in the network communicate with each other using a TCP/IP communication protocol, the framework comprising:

a mechanism constructed and adapted to determine a given function of a data file in the network, the given function being a message digest function or a hash function;

a set of content servers, distinct from the content provider server, for hosting at least some of the data files that are normally hosted by the content provider server;

wherein, in response to requests for a data file, generated by one of the client machines the request including an identifier based on the given function of the contents of the particular data file, the particular data file is served from one of the content servers.

54. A content delivery method in a network in which at least some processors in the network communicate with each other using a TCP/IP communication protocol, the method comprising:

for a particular data file having a particular name specifying a location in the network at which the data file may be located, determining another name for the particular data file, the other name including a data identifier determined using message digest function MD5 of the data, wherein said data used by the MD5 function comprises the contents of the particular data file; and

in response to a request for the particular data file, the request including the other name of the particular data file, causing the particular data file to be provided from a given one of the servers of the network of servers, wherein the data file may be a file, a portion of a file, a page in memory, a digital message, a digital image, a video signal or an audio signal.

55. A method, in a network comprising a plurality of processors, some of the processors functioning as servers and some of the processors functioning as clients, wherein some processors in the network communicate with each other using a TCP/IP communication protocol, wherein a key is required to identify a file on the network and wherein ordinarily the key is a name or address for the file, the method comprising:

storing some files on a first server in the network and storing copies of some of the files from the first server on a set of cache servers distinct from the first server;

for a particular file, determining a different cache key from the ordinarily used cache key for the file, the different cache key being determined using a message function MD5 of the data, wherein said data used by the MD5 function comprises the contents of the particular file; and

responsive to a client request for the particular file, the request including the different cache key for the file, causing the particular file to be provided to the client, wherein the data in the file may represent a digital message, a digital image, a video signal or an audio signal.

* * * * *