



US007318237B2

(12) **United States Patent**
Moriconi et al.

(10) **Patent No.:** **US 7,318,237 B2**
(45) **Date of Patent:** ***Jan. 8, 2008**

(54) **SYSTEM AND METHOD FOR MAINTAINING SECURITY IN A DISTRIBUTED COMPUTER NETWORK**

(75) Inventors: **Mark Moriconi**, Atherton, CA (US);
Shelly Qian, Cupertino, CA (US)

(73) Assignee: **Bea Systems, Inc.**, San Jose, CA (US)

(*) Notice: Subject to any disclaimer, the term of this patent is extended or adjusted under 35 U.S.C. 154(b) by 0 days.

This patent is subject to a terminal disclaimer.

(21) Appl. No.: **11/171,104**

(22) Filed: **Jun. 30, 2005**

(65) **Prior Publication Data**
US 2005/0257247 A1 Nov. 17, 2005

Related U.S. Application Data

(63) Continuation of application No. 09/767,610, filed on Jan. 22, 2001, now Pat. No. 6,941,472, which is a continuation of application No. 09/721,557, filed on Nov. 22, 2000, which is a continuation of application No. 09/248,788, filed on Feb. 12, 1999, now Pat. No. 6,158,010.

(60) Provisional application No. 60/105,963, filed on Oct. 28, 1998.

(51) **Int. Cl.**
H04L 9/00 (2006.01)

(52) **U.S. Cl.** **726/27; 726/1; 709/223**

(58) **Field of Classification Search** **726/27**
See application file for complete search history.

(56) **References Cited**

U.S. PATENT DOCUMENTS

5,173,939 A	12/1992	Abadi et al.	
5,237,614 A	8/1993	Weiss	
5,265,221 A	11/1993	Miller	711/163
5,347,653 A	9/1994	Flynn et al.	
5,355,474 A	10/1994	Thuraisingham et al.	
5,369,702 A	11/1994	Shanton	380/4
5,426,747 A	6/1995	Weinreb et al.	
5,481,700 A	1/1996	Thuraisingham	

(Continued)

FOREIGN PATENT DOCUMENTS

EP 0 398 645 A2 11/1990

(Continued)

OTHER PUBLICATIONS

U.S. Appl. No. 09/721,557, filed Nov. 22, 2000, Moriconi.

(Continued)

Primary Examiner—Nasser Moazzami
Assistant Examiner—Brandon S Hoffman
(74) *Attorney, Agent, or Firm*—Fliesler Meyer LLP

(57) **ABSTRACT**

A system and method for maintaining security in a distributed computing environment comprises a policy manager located on a server for managing and distributing a security policy, and an application guard located on a client for managing access to securable components as specified by the security policy. In the preferred embodiment, a global policy specifies access privileges of the user to securable components. The policy manager may then preferably distribute a local client policy based on the global policy to the client. An application guard located on the client then manages access to the securable components as specified by the local policy.

21 Claims, 14 Drawing Sheets

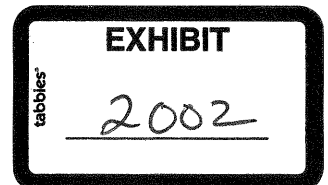
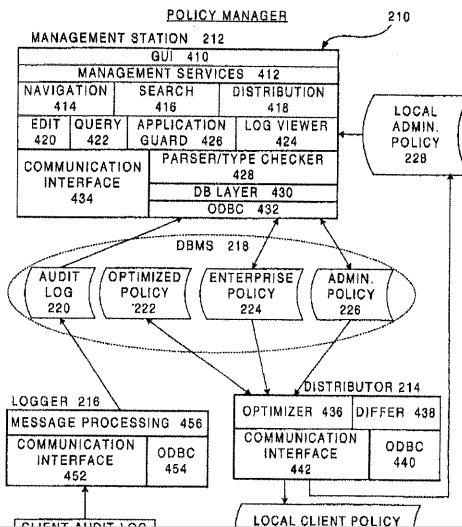

U.S. PATENT DOCUMENTS

5,544,322 A 8/1996 Cheng et al.
 5,557,747 A 9/1996 Rogers et al. 709/223
 5,627,886 A 5/1997 Bowman 379/111
 5,797,128 A 8/1998 Birnbaum
 5,809,230 A 9/1998 Pereira 713/200
 5,825,883 A 10/1998 Archibald et al.
 5,826,000 A 10/1998 Hamilton
 5,826,268 A 10/1998 Schaefer
 5,835,726 A 11/1998 Shwed 709/229
 5,841,869 A 11/1998 Merklng et al. 713/164
 5,848,396 A 12/1998 Gerace 705/10
 5,867,667 A 2/1999 Butman et al.
 5,889,953 A 3/1999 Thebaut et al.
 5,918,210 A 6/1999 Rosenthal et al.
 5,950,195 A 9/1999 Stockwell et al.
 5,956,400 A 9/1999 Chaum et al.
 5,956,521 A 9/1999 Wang
 5,966,707 A 10/1999 Van Huben et al.
 5,968,176 A * 10/1999 Nessellet et al. 726/11
 5,983,270 A 11/1999 Abraham et al. 709/224
 5,983,350 A 11/1999 Minear et al. 713/201
 5,987,469 A 11/1999 Lewis et al.
 5,987,611 A 11/1999 Freund
 5,991,877 A 11/1999 Luckenbaugh 713/200
 5,999,978 A 12/1999 Angal et al. 709/229
 6,005,571 A * 12/1999 Pachauri 715/764
 6,006,194 A 12/1999 Merel
 6,009,507 A 12/1999 Brooks et al. 712/28
 6,029,144 A 2/2000 Barrett et al.
 6,029,182 A 2/2000 Nehab et al. 715/523
 6,029,246 A 2/2000 Bahr
 6,035,399 A 3/2000 Klemba et al. 713/200
 6,055,515 A 4/2000 Consentino et al.
 6,073,242 A 6/2000 Hardy et al.
 6,083,276 A 7/2000 Davidson et al. 717/107
 6,098,173 A 8/2000 Elgressy et al.
 6,141,010 A 10/2000 Hoyle 715/854
 6,141,686 A 10/2000 Jackowski et al.
 6,148,333 A 11/2000 Guedalia et al.
 6,154,741 A 11/2000 Feldman 707/9
 6,154,844 A 11/2000 Touboul et al.
 6,157,924 A 12/2000 Austin 707/10
 6,158,010 A * 12/2000 Moriconi et al. 726/1
 6,167,407 A 12/2000 Nachenberg et al.
 6,167,445 A 12/2000 Gai et al.
 6,170,009 B1 1/2001 Mandal et al.
 6,182,226 B1 1/2001 Reid et al. 713/201
 6,182,277 B1 1/2001 Degroot et al.
 6,202,157 B1 3/2001 Brownlie et al.
 6,202,207 B1 * 3/2001 Donohue 717/173
 6,209,101 B1 3/2001 Mitchem et al.
 6,216,231 B1 4/2001 Stubblebine
 6,226,745 B1 5/2001 Wiederhold 713/200
 6,241,608 B1 6/2001 Torango 463/27
 6,253,321 B1 6/2001 Nikander et al.
 6,260,050 B1 7/2001 Yost et al. 715/501.1
 6,269,393 B1 7/2001 Yost et al. 709/201
 6,269,456 B1 7/2001 Hodges et al.
 6,275,941 B1 8/2001 Saito et al.
 6,285,366 B1 9/2001 Ng et al.
 6,285,985 B1 9/2001 Horstmann 705/14
 6,295,607 B1 9/2001 Johnson
 6,308,163 B1 10/2001 Du et al. 705/8
 6,317,868 B1 11/2001 Grimm et al.
 6,324,685 B1 11/2001 Balassanian
 6,341,352 B1 1/2002 Child et al.
 6,353,886 B1 3/2002 Howard et al.
 6,360,363 B1 3/2002 Moser et al.
 6,393,474 B1 5/2002 Eichert et al.
 6,397,222 B1 5/2002 Z...

6,412,077 B1 6/2002 Roden et al.
 6,418,448 B1 7/2002 Sarkar
 6,453,345 B2 9/2002 Trcka
 6,457,007 B1 9/2002 Kikuchi et al.
 6,460,141 B1 10/2002 Olden
 6,466,239 B2 10/2002 Ishikawa
 6,466,947 B2 10/2002 Aronold et al.
 6,473,791 B1 10/2002 Al-Ghosein et al.
 6,477,575 B1 11/2002 Koeppl et al.
 6,484,177 B1 11/2002 Van Huben et al.
 6,484,261 B1 11/2002 Wiegel
 6,519,647 B1 2/2003 Howard et al.
 6,530,024 B1 3/2003 Proctor
 6,539,375 B2 3/2003 Kawasaki 707/5
 6,539,414 B1 3/2003 Klein et al. 718/101
 6,571,247 B1 5/2003 Danno et al. 707/100
 6,584,454 B1 6/2003 Hummel et al.
 6,587,849 B1 7/2003 Mason et al. 707/5
 6,615,218 B2 9/2003 Mandal et al.
 6,618,806 B1 9/2003 Brown et al.
 6,654,747 B1 11/2003 Van Huben et al.
 6,665,677 B1 12/2003 Wotring et al.
 6,668,354 B1 12/2003 Chen et al. 715/517
 6,678,827 B1 1/2004 Rothermel et al.
 6,684,369 B1 1/2004 Bernardo et al.
 6,721,888 B1 4/2004 Liu et al.
 6,735,586 B2 5/2004 Timmons 707/3
 6,735,701 B1 5/2004 Jacobson
 6,738,789 B2 5/2004 Multer et al. 707/201
 6,751,659 B1 6/2004 Fenger et al.
 6,754,672 B1 6/2004 McLauchlin 707/104
 6,769,118 B2 7/2004 Garrison et al.
 6,779,002 B1 8/2004 Mwaura 707/203
 6,789,202 B1 9/2004 Ko et al.
 6,880,005 B1 4/2005 Bell et al.
 6,904,454 B2 6/2005 Stickler
 6,920,457 B2 7/2005 Pressmar
 6,922,695 B2 7/2005 Skufca et al. 707/10
 6,934,934 B1 8/2005 Osborne, II et al. 717/126
 6,941,472 B2 9/2005 Moriconi et al.
 6,950,825 B2 9/2005 Chang et al.
 6,957,261 B2 10/2005 Lortz
 6,965,999 B2 11/2005 Fox et al.
 6,970,876 B2 11/2005 Hotti et al.
 7,062,490 B2 6/2006 Adya et al.
 7,096,224 B2 8/2006 Murthy et al.
 7,174,563 B1 2/2007 Brownlie et al.
 2002/0059394 A1 5/2002 Sanders
 2002/0062451 A1 5/2002 Scheidt et al.
 2002/0069261 A1 6/2002 Bellare et al.
 2002/0107913 A1 8/2002 Rivera et al.
 2002/0173971 A1 11/2002 Stirpe et al.
 2002/0178119 A1 11/2002 Griffin et al.
 2003/0131113 A1 7/2003 Reeves et al.
 2003/0229623 A1 12/2003 Chang et al.
 2004/0205473 A1 10/2004 Fisher et al.
 2004/0205557 A1 10/2004 Bahrs et al.
 2004/0230546 A1 11/2004 Rogers
 2005/0050184 A1 3/2005 Boden et al.
 2005/0060324 A1 3/2005 Johnson et al.
 2006/0085412 A1 4/2006 Johnson et al.

FOREIGN PATENT DOCUMENTS

EP 1 256 889 A2 11/2002
 WO WO 98/40987 9/1998
 WO WO 98/40992 9/1998
 WO WO 98/54644 12/1998
 WO WO 99/57624 11/1999

WO 01/67285 A2 9/2001

OTHER PUBLICATIONS

- Eiji Okamoto, "Proposal for Integrated Security Systems", Jun. 1992, IEEE Computer Society Press, p. 354-358.
<http://java.sun.com/products/ejb/> (last visit: Dec. 7, 2004).
http://www.javaworld.com/javaworld/jw-12-2002/jw-1207-yesnoejb_p.html (last visit Dec. 7, 2004).
- Sunsted, Todd, "JNDI Overview, Part 1: An Introduction to Naming Services", JavaWorld, Jan. 2000, pp. 1-6, (downloaded from: www.javaworld.com/javaworld/jw-01-howto_p.html).
- Moore, Bill et al., "Migrating Weblogic Applications to WebSphere Advanced Edition", IBM Redbooks, Jan. 2001, pp. 1,3-4, 109-111 and 181-195.
- Barrett, Alexandra, "Trying Out Transactions", SunExpert Magazine, Jan. 1999, pp. 57-59.
- Ayers, Danny, et al., Professional Java Server Programming, Wrox Press, Ltd., Birmingham, UK, Dec. 1999, pp. 515-545.
- Ford, Nigel, Web Developer.com Guide to Building Intelligent Web Sites with JavaScript, Wiley Computer Publishing, New York, NY, © 1998, pp. 65-85, 96-98, 101-102, 245-250 and 324-327.
- Microsoft Computer Dictionary, 4th Edition, Microsoft Press, Redmond, WA © 1999, p. 489.
- Bankers Trust, "Authorization Manager-User Guide" Copyright Feb. 1997, Bankers Trust. Print Date: Aug. 13, 1997.
- Bankers Trust, "Security Instructions Services-User Guide" Copyright Feb. 1997, Bankers Trust. Print Date: Oct. 1, 1997.
- Entitlenet, Inc., 6 Webpages from Website, URL: www.entitlenet.com/ Publication Date Unknown, Download Date: Nov. 17, 2000.
- John Field, "From Authorization of Transactional Entitlement" Website of Transindigo, Inc., URL: www.transindigo.com/ Published: Sep. 2000.
- John Field, "Dynamic Enterprise Entitlement", Website of Transindigo, Inc., URL: www.transindigo.com/ Published: Sep. 2000.
- John Field, Using Elara (TM), Website of Transindigo, Inc., URL: www.transindigo.com/ Published: Sep. 2000.
- Author Unknown, "AppShield (TM Version 3.0)," (White Paper), Website of Sanctum, Inc., URL: www.sanctuminc.com Published Dec. 2000.
- Hunter, Jason, "Java Servlet Programming", second edition, O'Reilly, Apr. 11, 2001.
- USDataCenters . . . eBusiness, Business Wire, p. 2079. Apr. 4, 2001.
- European Search Report for 02723874.0 dated Jun. 7, 2006 (3 pages).
- Symborski, C.W., "Updating software and configuration data in a distributed communications network", Computer Networking Symposium, Washington, D.C., 1988, pp. 331-338.
- European Search Report for EP 02 77 3915 dated Oct. 5, 2006 (3 pages).
- Zhang, Zheng, et al., "Designing a Robust Namespace for Distributed File Services", Reliable Distributed System, 2001, Proceedings 20th IEEE Symposium on Oct. 28-31, 2001, pp. 162-171.
- Adya, Atul, et al., "Farsite: Federated, Available, and Reliable Storage for an Incompletely Trusted Environment" ACM SIGOPS Operating Systems Review, vol. 36, Issue SI (Winter 2002), OSDI '02, Proceedings of the 5th Symposium on Operating Systems Design and Implementation, pp. 1-14.
- Adomavicius, Gediminas, et al., "User Profiling in Personalization applications Through Rule Discovery and Validation", KDD '99, San Diego, CA, 1999, pp. 377-381.
- Cingil, Ibrahim, et al., "A Broader Approach to Personalization", Communications of the ACM, vol. 43, No. 6, Aug. 2000, pp. 136-141.
- Stephanidis, Constantine, et al., "Decision Making in Intelligent User Interfaces", IUI '97, Orlando, FL, 1997, pp. 195-202.
- Stiemerling, Oliver, et al., "How to Make Software Softer—Designing Tailorable Applications", DIS '97, Amsterdam, The Netherlands, 1997, pp. 365-376.
- Freudenthal, Eric et al., "dRBAC: Distributed Role-Based Access for Dynamic Coalition Environments", Proceedings of the 22nd International Conference on Distributed Computing Systems (ICDCS '02), IEEE 2002, 10 pages.
- Howes, T., "The String Representation of LDAP Search Filters," Netscape Communications Corp., Request for Comments: 2254, 8 pages (Dec. 1997).
- Supplementary European Search Report for EP 01 97 5484 dates Dec. 19, 2006, 2 pages.
- Kistler, Thomas, et al., "WebL—A Programming Language for the Web," Computer Networks and ISDN Systems, North Holland Publishing, Amsterdam, NL, vol. 30, No. 1-7, pp. 259-270 (Apr. 1998).
- Levy, Michael R., "Web Programming in Guide," Software Practice & Experience, Wiley & Sons, Bognor Regis, GB, vol. 28, No. 15, pp. 1581-1603 (Dec. 25, 1998).
- Atkins, David L., et al., "Mawl: A Domain-Specific Language for Form-Based Services," IEEE Transactions on Software Engineering, IEEE Service Center, Los Alamitos, CA, US, vol. 25, No. 3, pp. 334-346 (May 1999).
- Parker, Elisabeth, The Complete Idiot's Guide® to Microsoft® FrontPage 2000, QUE®, Indianapolis, IN, pp. 7 and 52 (1999).
- Tanyi, Emmanuel, "Easy XML," www.winsite.com, pp. 1-6 (Mar. 2000).
- "Method and System for Visually Constructing Document Type Definitions and Related Artifacts Using a Reusable Object Model," IBM Technical Disclosures Bulletin, May 31, 2001, 3 pages.
- Candan, K. S., "Enabling Dynamic Content Caching for Database-Driven Web Sites," Proceedings of the 2001 ACM SIGMOD International Conference on Management of Data, May 21-24, 2001, Santa Barbara, CA, US, pp. 532-543.
- Catley, Christina, et al., "Design of a Health Care Architecture for Medical Data Interoperability and Application Integration," Proceedings of the Second Joint EMBS/BMES Conference, Houston, Texas, US, Oct. 23-26, 2002, IEEE, vol. 3, pp. 1952-1953.
- Browne, Shirley, et al., "Location-Independent Naming for Virtual Distributed Software Repositories," ACM Symposium on Software Reusability, Seattle, WA, US, vol. 20, Issue SI, pp. 179-185 (Aug. 1995).

* cited by examiner



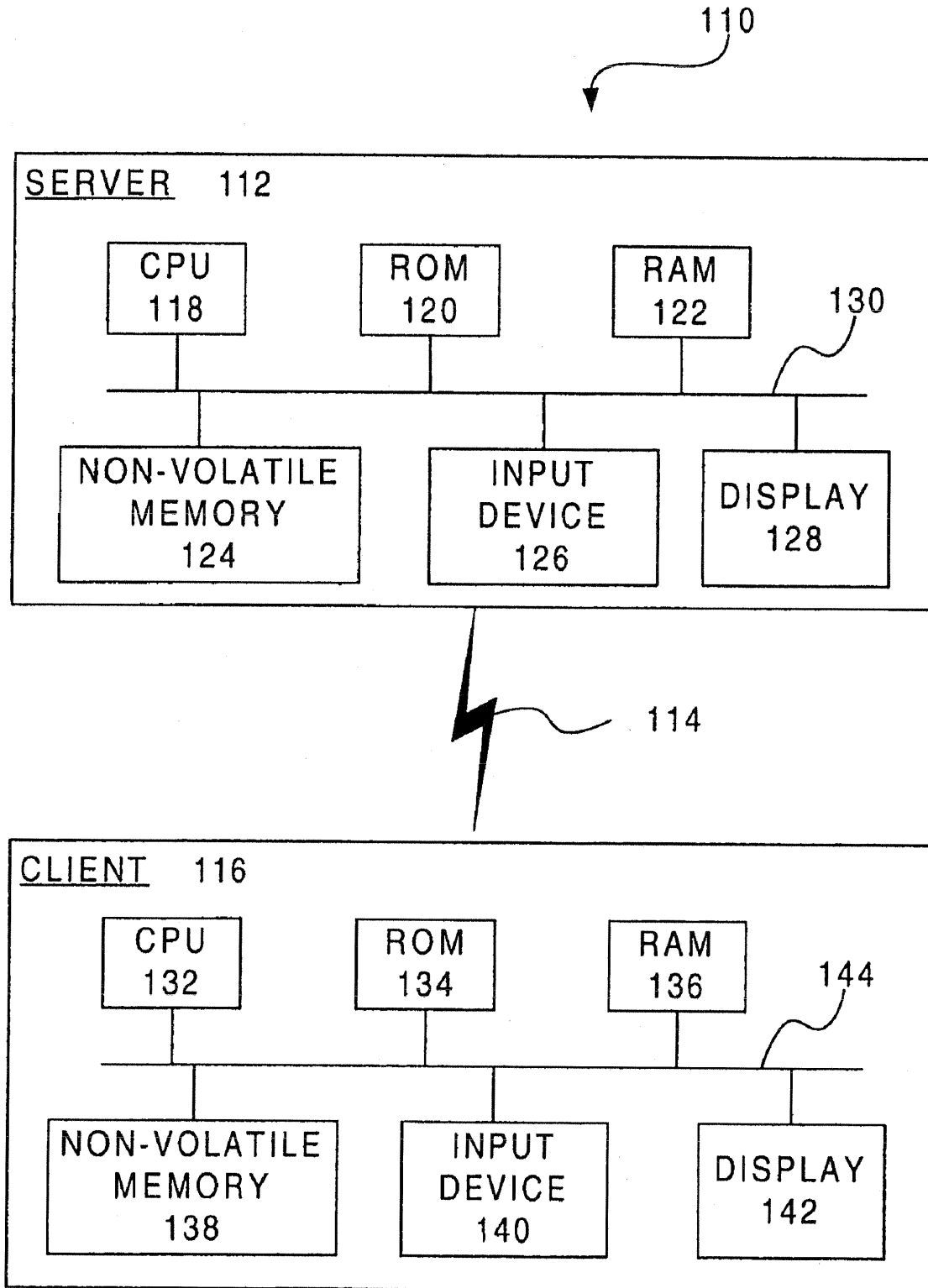

FIG. 1

SERVER

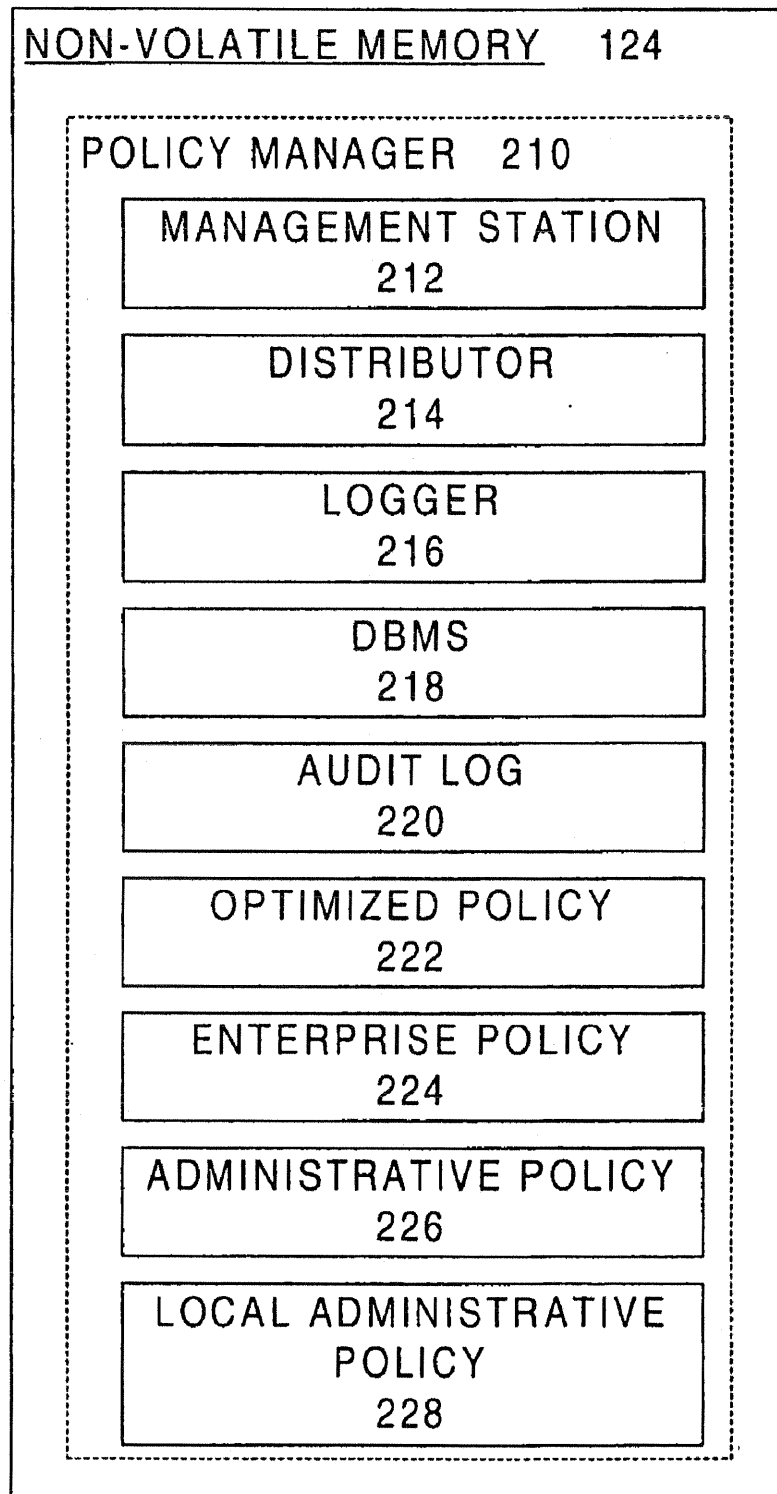

FIG. 2

Explore Litigation Insights

Docket Alarm provides insights to develop a more informed litigation strategy and the peace of mind of knowing you're on top of things.

Real-Time Litigation Alerts



Keep your litigation team up-to-date with **real-time alerts** and advanced team management tools built for the enterprise, all while greatly reducing PACER spend.

Our comprehensive service means we can handle Federal, State, and Administrative courts across the country.

Advanced Docket Research



With over 230 million records, Docket Alarm's cloud-native docket research platform finds what other services can't. Coverage includes Federal, State, plus PTAB, TTAB, ITC and NLRB decisions, all in one place.

Identify arguments that have been successful in the past with full text, pinpoint searching. Link to case law cited within any court document via Fastcase.

Analytics At Your Fingertips



Learn what happened the last time a particular judge, opposing counsel or company faced cases similar to yours.

Advanced out-of-the-box PTAB and TTAB analytics are always at your fingertips.

API

Docket Alarm offers a powerful API (application programming interface) to developers that want to integrate case filings into their apps.

LAW FIRMS

Build custom dashboards for your attorneys and clients with live data direct from the court.

Automate many repetitive legal tasks like conflict checks, document management, and marketing.

FINANCIAL INSTITUTIONS

Litigation and bankruptcy checks for companies and debtors.

E-DISCOVERY AND LEGAL VENDORS

Sync your system to PACER to automate legal marketing.