

(12) **United States Patent**
McManus et al.

(10) **Patent No.:** **US 6,401,070 B1**
(45) **Date of Patent:** **Jun. 4, 2002**

(54) **SYSTEM AND METHOD FOR PROVIDING HOUSE PRICE FORECASTS BASED ON REPEAT SALES MODEL**

(75) Inventors: **Douglas A. McManus**, Bethesda, MD (US); **Sol T. Mumey**, McLean, VA (US)

(73) Assignee: **Freddie Mac**, Vienna, VA (US)

(*) Notice: Subject to any disclaimer, the term of this patent is extended or adjusted under 35 U.S.C. 154(b) by 0 days.

(21) Appl. No.: **09/115,831**

(22) Filed: **Jul. 15, 1998**

Related U.S. Application Data

(63) Continuation of application No. 08/730,289, filed on Oct. 11, 1996.

(60) Provisional application No. 60/059,327, filed on Sep. 17, 1997, provisional application No. 60/059,194, filed on Sep. 17, 1997, and provisional application No. 60/059,328, filed on Sep. 17, 1997.

(51) **Int. Cl.⁷** **G06F 17/60**

(52) **U.S. Cl.** **705/1; 705/10; 705/35; 705/37**

(58) **Field of Search** **705/1, 10, 35, 705/37**

(56) **References Cited**

U.S. PATENT DOCUMENTS

5,361,201 A	*	11/1994	Jost et al.	705/35
5,414,621 A	*	5/1995	Hough	705/10
5,500,793 A	*	3/1996	Deming, Jr. et al.	705/37
5,680,305 A	*	10/1997	Apgar	705/10
5,857,174 A	*	1/1999	Dugan	705/1

OTHER PUBLICATIONS

Lew Sichelman; "Determining home's proper selling price", National Mortgage News, Sep. 29, 1997.*

Clapp et al. "Estimating Time Adjustments with Sales Prices and Assesed Values", The Appraisal Journal, Jul. 1996.*

Cocheo, "Appraisals: A Trade under Renovation", ABA Banking Journal Feb. 1996.*

Fritz Wayne C., "Real Estate Appraisal Concepts", Economic development Review, Winter 1996.*

Detweiler et al., "Computer Assisted Real Estate Appraisal", The Appraisal Journal, Jan. 1996.*

Janavicius John M., "A Formula for Tax Appraisal of Mult-Tenant Properties", The Appraisal Journal, Oct. 1996.*

Jesse M. Abraham and William S. Schauman, Secondary Mortgage Markets/Winter 1990/1991, "Measuring House Price Inflation, Sizing Up Alternative Methods," pp. 8-12. G.A.F. Seber and C.J. Wild, "Nonlinear Regression," Department of Mathematics and Statistics, University of Auckland, New Zealand, John Wiley & Sons (1989), pp. 481-486.

Martin J. Bailey, Richard F. Muth, and Hugh O. Nourse, American Statistical Association Journal, Dec. 1963, "A Regression Method for Real Estate Price Index Construction," pp. 933-942.

Peter Chinloy, Man Cho, and Isaac F. Megbolugbe, The Journal of Real Estate Finance and Economics, "Appraisals, Transaction Incentives, and Smoothing," pp. 89-111 (1997). Evaluation and Combination of Forecasts, Chapter 8.

Econometrics, G.S. Maddala, pp. 314-317 (1977).

Economic Forecasting: An Introduction, pp. 85-107 (1994).

Forecasting Economic Time Series, pp. 265-276 (2d ed., 1986).

* cited by examiner

Primary Examiner—V. Millin

Assistant Examiner—Jagdish N Patel

(74) *Attorney, Agent, or Firm*—Finnegan, Henderson, Farabow, Garrett & Dunner, L.L.P.

(57) **ABSTRACT**

Method and system for estimating real estate property values based on repeat sales model. The method estimates the price index using property value data from refinance transactions, as well as from purchase transactions. In so estimating, the method compensates for the transaction bias arising from using data from refinance transactions, which may exhibit incentive and selection biases. The property at issue may be estimated based on the so-computed price index. The price index and/or the bias component may be estimated using nonparametric functions.

102 Claims, 5 Drawing Sheets

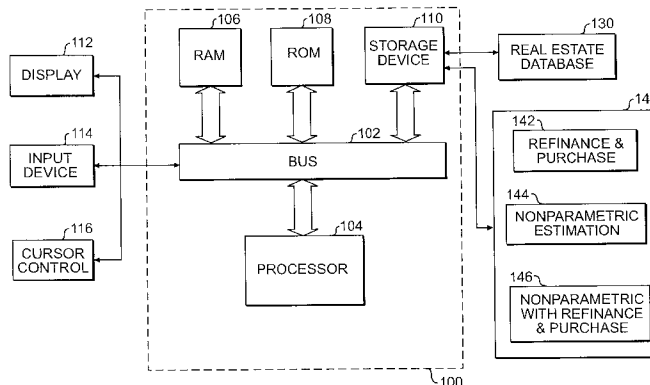

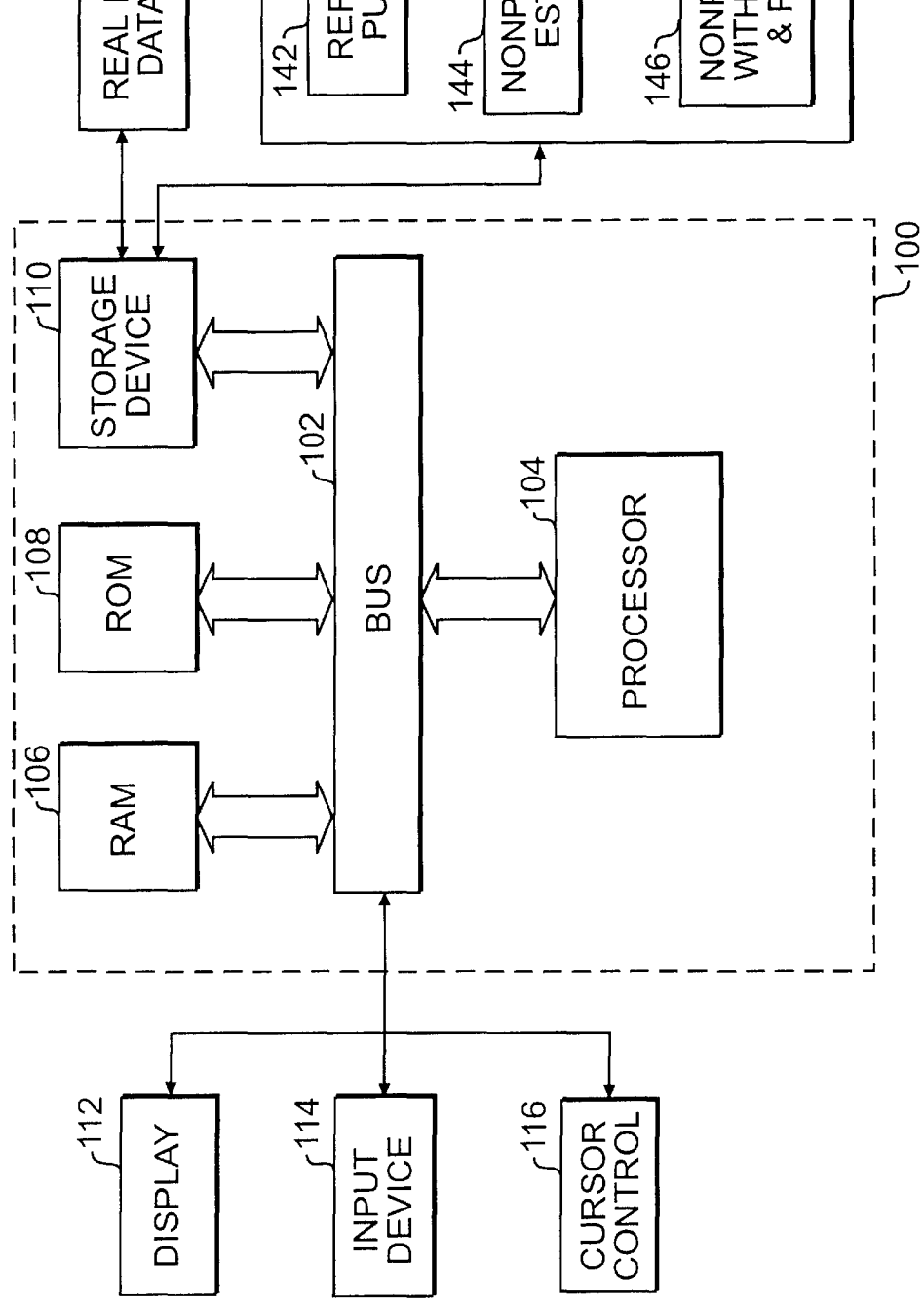

FIG. 1

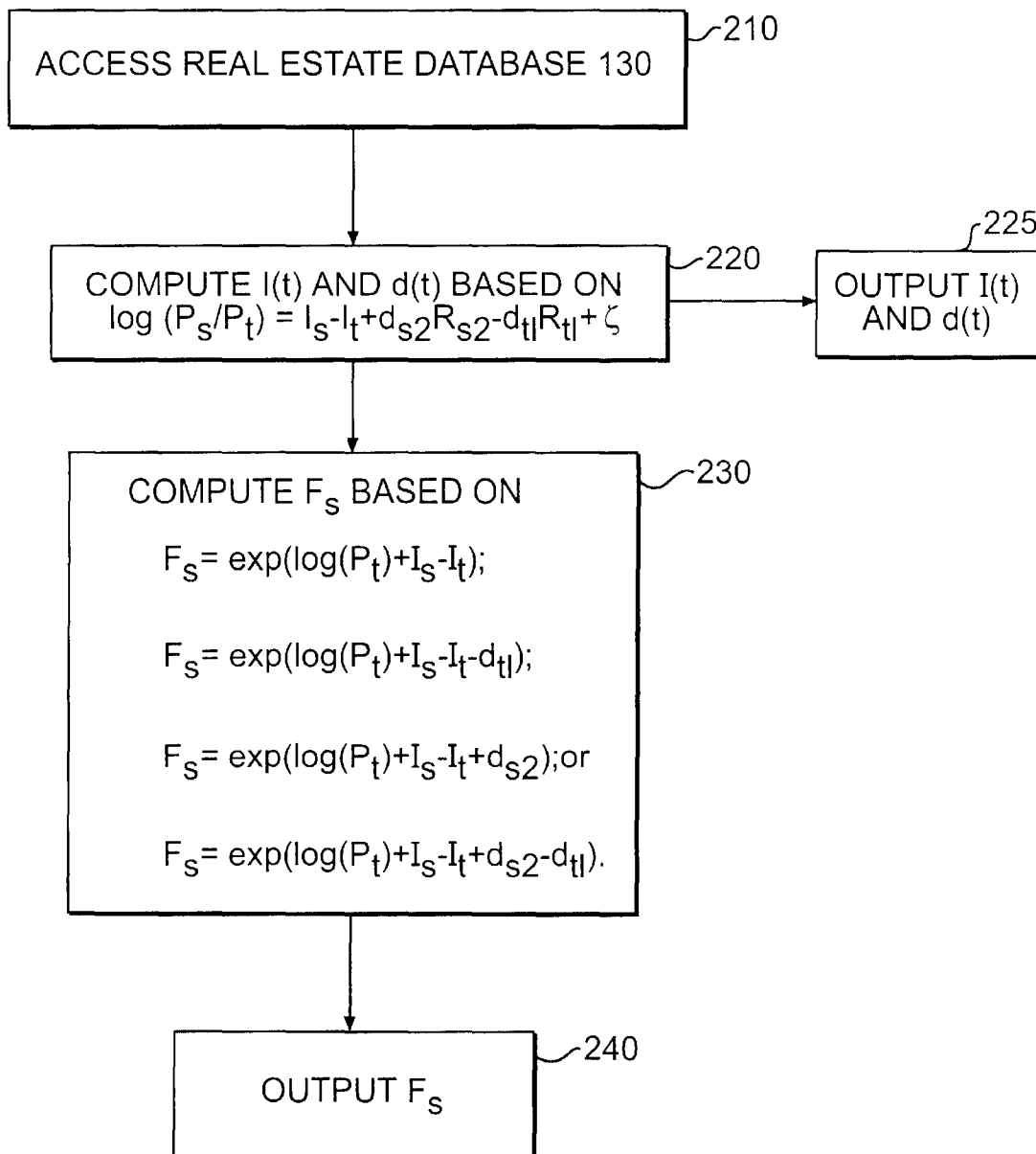
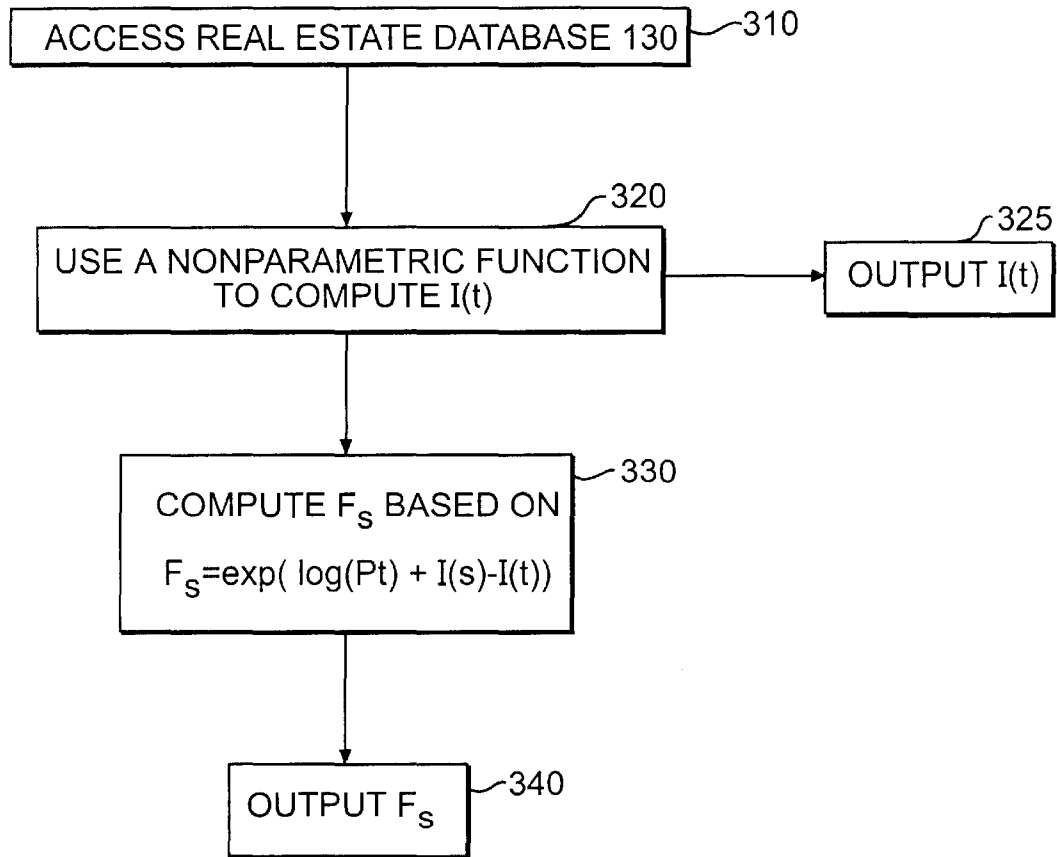

FIG. 2

**FIG. 3**

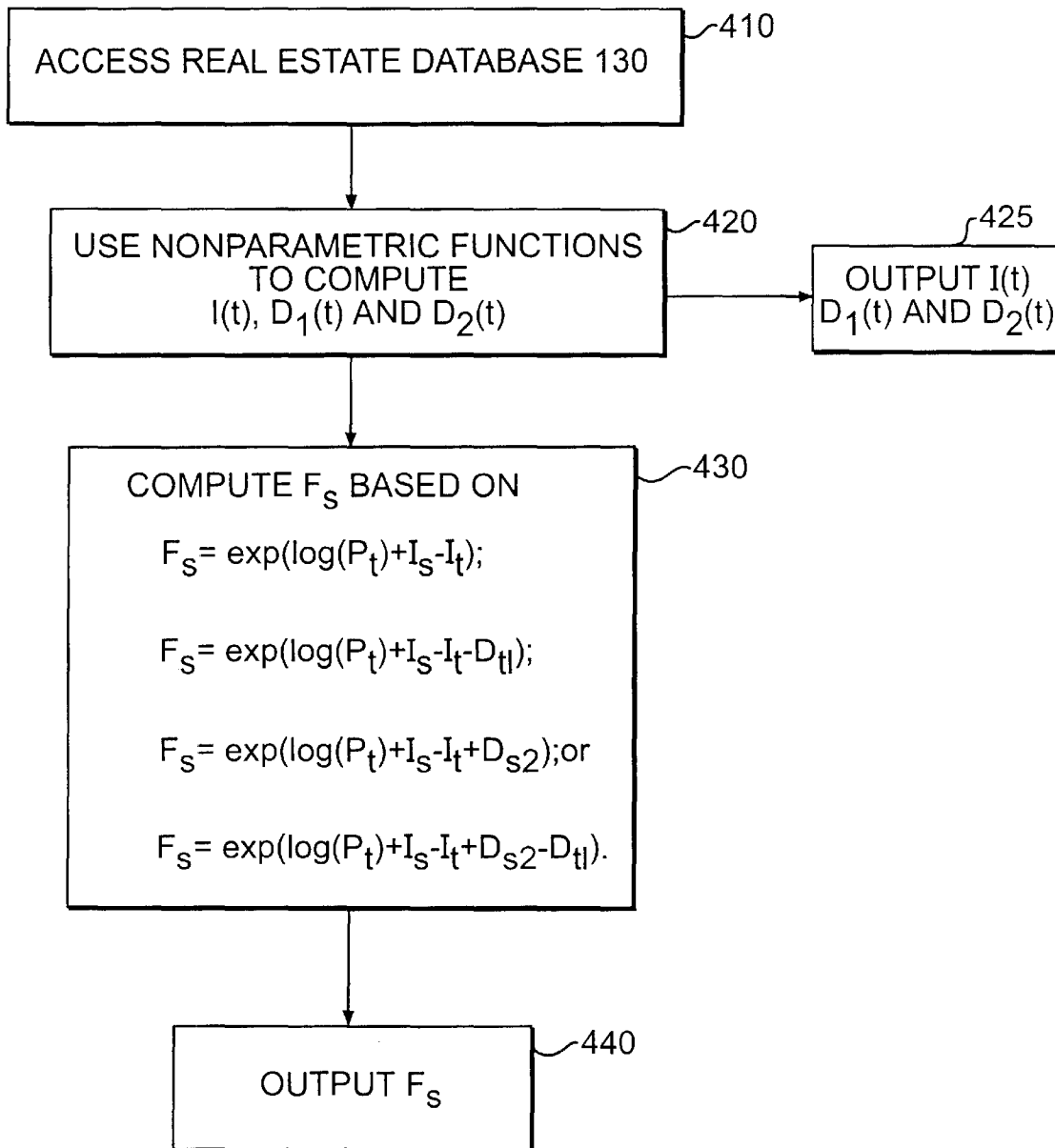

FIG. 4

Explore Litigation Insights

Docket Alarm provides insights to develop a more informed litigation strategy and the peace of mind of knowing you're on top of things.

Real-Time Litigation Alerts



Keep your litigation team up-to-date with **real-time alerts** and advanced team management tools built for the enterprise, all while greatly reducing PACER spend.

Our comprehensive service means we can handle Federal, State, and Administrative courts across the country.

Advanced Docket Research



With over 230 million records, Docket Alarm's cloud-native docket research platform finds what other services can't. Coverage includes Federal, State, plus PTAB, TTAB, ITC and NLRB decisions, all in one place.

Identify arguments that have been successful in the past with full text, pinpoint searching. Link to case law cited within any court document via Fastcase.

Analytics At Your Fingertips



Learn what happened the last time a particular judge, opposing counsel or company faced cases similar to yours.

Advanced out-of-the-box PTAB and TTAB analytics are always at your fingertips.

API

Docket Alarm offers a powerful API (application programming interface) to developers that want to integrate case filings into their apps.

LAW FIRMS

Build custom dashboards for your attorneys and clients with live data direct from the court.

Automate many repetitive legal tasks like conflict checks, document management, and marketing.

FINANCIAL INSTITUTIONS

Litigation and bankruptcy checks for companies and debtors.

E-DISCOVERY AND LEGAL VENDORS

Sync your system to PACER to automate legal marketing.