

PREFACE

FLAT-PANEL DISPLAYS AND CRTs

Edited by
Lawrence E. Tannas, Jr.

displays industry for
is form with the color
) and adapted as such
s an approximation of
, Lancaster, PA., and

VNR VAN NOSTRAND REINHOLD
New York

Copyright © 1985 by Van Nostrand Reinhold

Library of Congress Catalog Card Number 84-11839
ISBN 0-442-28250-8

All rights reserved. No part of this work covered by the copyright hereon may be reproduced or used in any form or by any means—graphic, electronic, or mechanical, including photocopying, recording, taping, or information storage and retrieval systems—without permission of the publisher.

Manufactured in the United States of America

Van Nostrand Reinhold
115 Fifth Avenue
New York, New York 10003

Van Nostrand Reinhold International Company Limited
11 New Fetter Lane
London EC4P 4EE, England

Van Nostrand Reinhold
480 La Trobe Street
Melbourne, Victoria 3000, Australia

Nelson Canada
1120 Birchmount Road
Scarborough, Ontario M1K 5G4, Canada

15 14 13 12 11 10 9 8 7 6 5 4 3

Library of Congress Cataloging in Publication Data

Main entry under title:

Flat-panel displays and CRTs.

Includes index.

1. Information display systems. 2. Cathode-ray tubes.

I. Tannas, Jr., Lawrence E.

TK7882.I6F53 1984

381.3819'532

84-11839

ISBN 0-442-28250-8

PREFACE

Flat-Panel Displays is a systematic and concise treatment of flat-panel displays from a perspective, the

The field of flat-panel displays has developed rapidly in the past few years. This book is intended to provide a comprehensive and up-to-date survey of the field for another technician.

This book has been written for the technician who is interested in which a new set of materials for use in flat-panel displays; the middle description of the

Flat-Panel Displays discuss CRTs and "The Challenge of Flat-Panel Displays"

It is obvious that the ideal replacement for the CRT has created a great deal of interest on the air of a new era in flat-panel displays when, if ever, they will be used in various applications. I, myself, have a niche of its own and no longer the CRT. If the time should come when the CRT they may.

This book is a comprehensive treatment of the electronic drive hardware system, brain system, whether the drive it makes no sense in terms of requirements. performance in this chapter on information pattern recognition.

1.5 CLASSIFICATION NOMENCLATURE

In any field of endeavor, it is desirable to use standard classification nomenclature. In the display industry, there has been a rush to form new acronyms. Without denying inventors the right to name their new display, a standard generic classification of displays can be used. The outline for such a classification is shown in Table 1-3. The table lists the key words which can be used to categorize any display device. As an example of the use of this scheme, one of the first liquid-crystal displays is classified as:

- Phenomenon: Liquid crystallinity (LC)
- Material: MBBA and EBBA with dopant
- Contrast: Dynamic scattering with back lighting
- Addressing: Direct with ac refresh
- Application: Numeric

This generic classification could be reduced to key words to describe display devices in technical reports, papers, and dissertations.

Table 1-3 Generic Classification for Flat-Panel Displays

Phenomenon	The primary physical phenomenon used to create a particular visual effect. Examples: liquid crystallinity, electrophoresis, light-emitting diodes.
Material	The chemical name and physical state of the display material. Examples: Mn activated ZnS thin-film phosphor, doped MBBA/EBBA.
Contrast	The electrically alterable medium used to create contrast between picture elements. Examples: birefringence, absorption, green luminance on a black background.
Addressing	The method for controlling an array of picture elements. Examples: direct, scan, grid shift, or matrix addressing, with memory or refresh, ac or dc, intrinsic or extrinsic.
Application	The display category most suited. Examples: analog, alphanumeric, vectorgraphic, or video.

If an acronym is needed in the paper, the phenomenon need only be abbreviated, such as LED for light-emitting diode, LC for liquid crystallinity, or GD for gas discharge. The reader has been informed of the other features such as ac or dc, memory or refresh, thin film or powder. Trademarks could be used in place of the abbreviations where it is necessary to refer to specific manufacturer's product or approach.

Further, it makes for easier reading if the letter "D" for display is left out of the acronym. It is easier to read "The EL display uses less power . . ." than "The ELD uses less power . . ." and there is more information in "an EL display" to assist the unfamiliar reader. Additionally, the acronym can be used as an adjective, such as in EL powder, EL light, etc.

1.6 PICTURE ELEMENT OR PIXEL

The basic building block for all displays is the picture element as shown in Fig. 1-10. The noun "pixel" is formed from the contraction of "picture element" and is almost universally used in its place. The pixel is the smallest resolvable spatial-information element as seen by the viewer. There is no spatial information in a display below the resolution of the pixel area.

Some authors, particularly in the word-processing industry use the contraction "pel." By consensus, "pixel" is preferred. Pixel has been directly translated into French, German, Japanese, and other languages with the same meaning.

The pixel may be further subdivided to achieve color (see Fig. 1-11) or gray shades (Fig. 1-12). The key point is that the pixel is the lowest resolvable spatial incremental quantum. The other display dimensions of hue (color), saturation (color purity), luminance (gray shades), and time are all independent of the spatial dimension.

As an example of pixel subdivision, color is often achieved using three dots per pixel, one red, one green, and one blue within the spatial area. A clever geometric arrangement can be used with matrix-addressed displays, as depicted in Fig. 1-11b. Neighboring pixels can share color dots if properly programmed. In this case, the active area is much larger than the pixel spatial area.

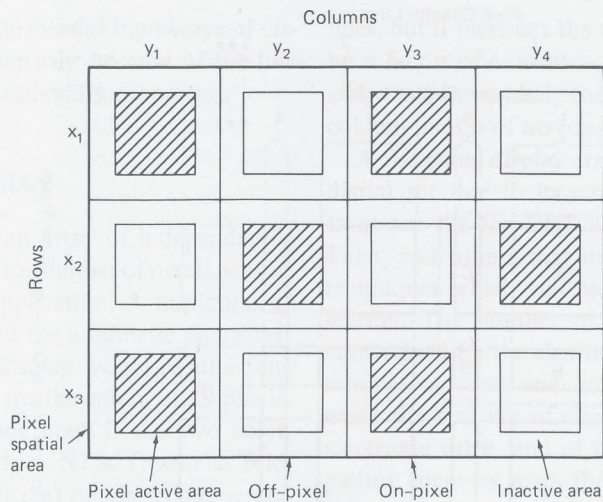

Fig. 1-10. Nomenclature of a flat-panel display pixel array.

Several resolution lines in the rows or columns or both can be used for gray shades. For example, the intersection of two row and two column electric leads in matrix addressing can be used to define a single pixel. The pixel is then made up of four dots, and the excitation of different numbers of dots can be used for gray shades. In Fig. 1-12 the dots are of different size so that fairly uniform steps of sixteen gray shades can be portrayed using all combinations of the four dots.

The pixel spatial dimensions can be defined by their pitch. The resolution is the reciprocal of pitch and is quoted as display lines per inch or millimeter. Display lines do not have spaces

in the sense that optical lines have spaces. For example, it takes a minimum of two display lines to represent an optical line and its space. An optical line space is represented by a display line turned off.

To display 20 optical lines per inch, for example, requires 40 display lines (TV lines) times the Kell factor of 1.4 for a total of 56 display lines per inch. The Kell factor is used to determine the number of TV raster lines needed to reproduce a resolution test chart. Other methods are used today, as discussed in Chap. 4.

The active area may be less than the pixel area, as shown in Fig. 1-10. The checkerboard pattern in Fig. 1-10 is useful as a test pattern

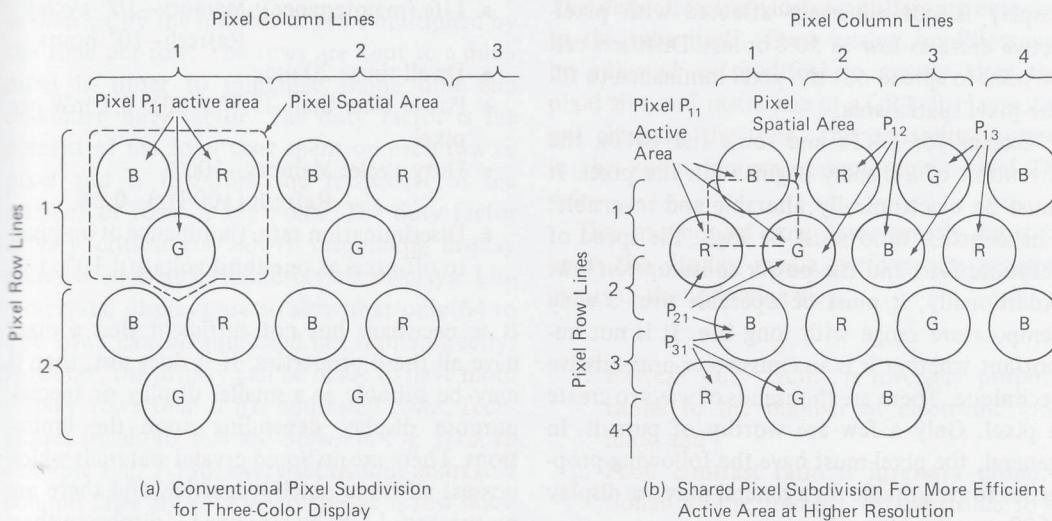

Fig. 1-11. Pixel subdivision for color.

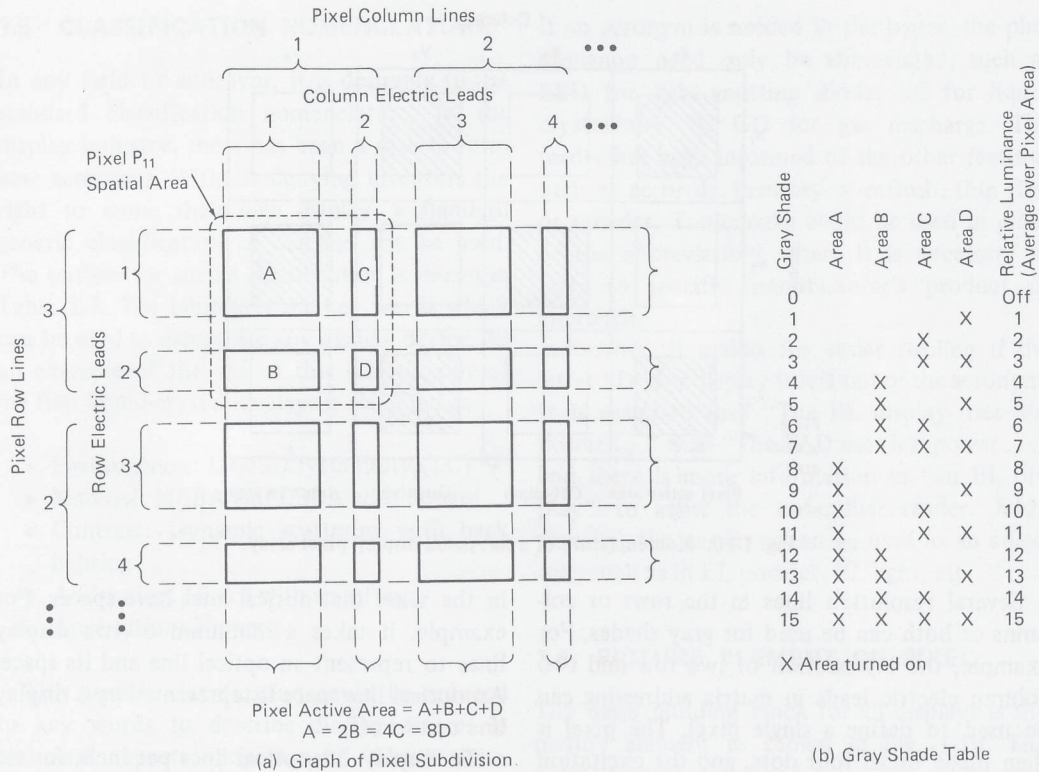

Fig. 1-12. Pixel subdivision for gray shades.

for measuring contrast ratio between on-pixel and off-pixel. Using this test pattern would lead to a conservative measure of contrast ratio, since each off-pixel is surrounded by on-pixels which can indirectly contribute to the brightness of the off-pixel by light piping or scattering. Studies have shown that the readability of an emissive display is not adversely affected with pixel-active areas as low as 50% or less. Diffusers can be used to spread out the pixel luminance to fill the pixel spatial area.

Except for CRTs and some flat CRTs, the invention of a display begins with the pixel. It must be electronically alterable and reversible. The contrast ratio must be high, the speed of response fast, and the power consumption low. Additionally, it must be operable over a wide temperature range with long life. It is not important whether it is an emissive or nonemissive technique. There are thousands of ways to create a pixel. Only a few are worthy of pursuit. In general, the pixel must have the following properties to be suitable for a general-purpose display (500 rows by 500 columns):

- Resolution: 64 lines/in.
- Pixel contrast ratio: 10:1 (over a wide ambient illumination range)
- Directionality: Lambertian over 60-deg cone from normal
- Operating temperature range: -40°C to 80°C
- Life (maintenance): Memory-10⁶ cycles
Refresh-10⁴ hours
- Dwell time: 20 μsec
- Power (less than 25 W total): 0.1 mW per pixel
- Duty cycle: Memory-100%
Refresh (100 Hz)-0.2%
- Discrimination ratio (luminance of on-pixel to off-pixel at one-third voltage): 10⁴ : 1

It is necessary but not sufficient that a pixel have all these properties. If it does not, then it may be suitable as a smaller display or special-purpose display depending upon the limitations. There are no liquid-crystal materials which possess all these pixel properties, and there are no successful 500 by 500-line LC displays either.

Yet there are many su
play applications prin
power and sunlight re

1.7 DISPLAY ARR

A display is simply
controllable pixels. TH
depends upon the ap
seven pixels is neede
A four-digit watch d
times seven plus one t
The colon is only on
dots are not independ
vision System Comm
television requires app
(480 rows by 320 co
a pixel array (digital
The total pixel co
fresh time, color, etc
total instantaneous i
picture.

The array is norm
columns. The address
row number and c
counting from the
shown in Fig. 1-11
trois the state of th
address.

In matrix-address
are normally address
The complete array
time, and the time t
is then set by the nu
the time per row. T
mum in order to
maximize duty fac
percent of the total
pixel and is there
number of rows, a
is very critical for
material such as in
uid-crystal displays
128 rows can be a
However, the displ
display rows than
requires for doing th
example Fig. 1-13
column lines are r
This complicates t

Yet there are many successful liquid-crystal display applications primarily because of the low power and sunlight readability properties.

1.7 DISPLAY ARRAY

A display is simply an array of independently controllable pixels. The number of pixels needed depends upon the application. A minimum of seven pixels is needed for a numeric character. A four-digit watch display would require four times seven plus one for the colon, or 29 pixels. The colon is only one pixel if the two colon dots are not independent. NTSC (National Television System Committee) standard commercial television requires approximately 150,000 pixels (480 rows by 320 columns) when displayed in a pixel array (digital equivalent).

The total pixel count is independent of refresh time, color, etc. The pixel count limits the total instantaneous information content of the picture.

The array is normally organized in rows and columns. The address of a pixel is defined by its row number and column number, normally counting from the upper left-hand corner as shown in Fig. 1-10. The electronic drive controls the state of the pixels according to their address.

In matrix-addressed displays, all the columns are normally addressed in parallel to save time. The complete array is addressed one row at a time, and the time to address the complete array is then set by the number of rows multiplied by the time per row. The rows are kept to a minimum in order to minimize frame time and maximize duty factor. The duty factor is the percent of the total time spent on each row or pixel and is therefore the reciprocal of the number of rows, a key point. The duty factor is very critical for slowly responding display material such as in liquid-crystal displays. Liquid-crystal displays are so slow that only 64 to 128 rows can be addressed per frame directly. However, the display can be made to have more display rows than it has addressed rows. Techniques for doing this are shown in Fig. 1-13. In example Fig. 1-13d, every set of four addressed column lines are rotated to appear as row lines. This complicates the data signal and electrode

lines, but it increases the useful display row lines by a factor of 4 or more. Since the columns are addressed in parallel, the number of addressed column lines is of no consequence, time-wise.

A flat-panel display array is normally a fixed-digital set due to its construction; the exceptions are the flat-CRT Aiken Tube, the Gabor Tube, and others that use the scan addressing techniques which will be discussed in the next section. The number of rows and columns is constrained by the electrode configuration. The number of rows and columns is discrete. To make the best use of electronic counters in the electronic drive, and of memory locations in a picture memory map, the number of rows and columns is often a power of two, such as 256 rows by 512 columns.

The CRT, Aiken Tube, and Gabor Tube are analog displays. The pixel locations are defined by an analog voltage on the vertical and horizontal deflection amplifiers. The display array is called a raster scanning pattern or Lissajous pattern. The pixel size, called a spot size (diameter at 50% luminance), is principally defined by the electron beam focus, the video amplifier bandwidth, and the phosphor light diffusion. The number of rows and columns possible in a CRT corresponds to the raster vertical dimension divided by the spot vertical dimension and the raster horizontal dimension divided by the spot horizontal dimension, respectively.

The CRT display phosphor screen is usually continuous and without electrode definition. The deflection and video amplifiers are external to the tube itself. These analog amplifiers can be adjusted or modified to greatly alter the pixel size and raster size of a CRT display without changing the tube. This capability is used in the zoom feature of some commercial TV sets.

The number of row lines greatly impacts upon the display media performance requirements in the following way:

1. Refresh duty factor is inversely proportional to the number of electronic row lines, and
2. Pixel contrast ratio is inversely proportional to the number of electronic row lines.

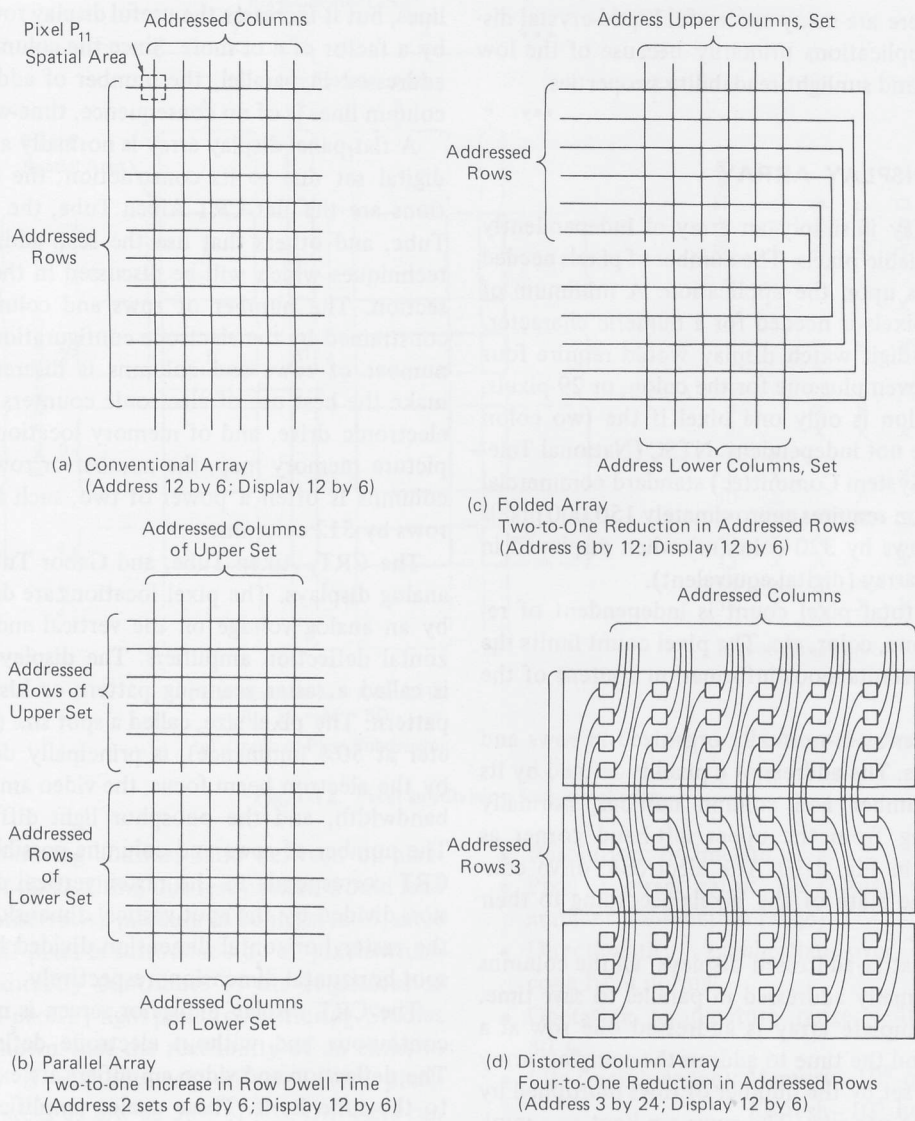

Fig. 1-13. Techniques for reducing row addressing time.

The requirements on the display media can be reduced if the electronically addressed row lines can be reduced. The first and obvious thing is to simply skew the presentation by increasing the column lines and reducing the row lines. This distorts the display presentation and can only be used within limits. The next step is to reduce the electronic rows without reducing the displayed rows by using techniques such as those shown in Fig. 1-13.

1.7.1 Duty Factor. A display is addressed or strobed sequentially. The time spent on each pixel is inversely proportional to the number of

pixels and is called the *duty factor*. For an array of 500 by 500 the duty factor becomes 4 parts per million, or .0004%, which is quite small. Only CRT phosphors and LEDs can operate satisfactorily with a duty factor this small.

The duty factor can be greatly increased by using line-at-a-time addressing. That is to say, a complete row is addressed in parallel, and the rows are then commutated sequentially. For an array of 500 by 500 the duty factor becomes 2 parts per thousand, or .2%, which is a significant improvement. This is why line-at-a-time addressing is used whenever it is at all practical and why the number of addressed rows is kept

to a minimum. How hard

is inversely proportional to
A second consideration
time. This is the time re
on to its required lumin
dwell time is the pro
and the frame time. Fo
by 500 addressed or ref
second, the frame time
line-at-a-time addressi
.2%, which computes
sec.

Each technology has
quired dwell time, as si
response of most CRT
for a 120 nsec dwell tim
time requirements can li
or the refresh rate. Th
why the techniques of
reduce the number of a
be required, for exam
displays. The CRT can
addressing, and the use
type scan addressing is
300 arrays.

1.7.2 Pixel Contrast Ra
Ratio is simply the
the on pixel to the o
environment. The inf
environment will be c
can left simply with th
ing the pixel contrast r
demonstrate the signif
row lines on the pixel
contrast ratio for refe
line-at-a-time addressi

$$PCR = \frac{L_{on}}{L_{off}}$$

where PCR is pixel c
luminance of the pixel
the luminance of a p
when another pixel is
number of electronical
The derivation of t
theoretically. Consider
row lines must be st
refreshing the display
upon the display add

Most display technologies in combination with the addressing techniques have a limited discrimination ratio.

1.8 ADDRESSING

For the uninitiated, the least understood and most underestimated task in flat-panel displays is that of addressing the hundreds of thousands of pixels. It is the single most difficult problem. The solution chosen has a great impact on the display cost. The problem is to convert a serial electrical data sequence into a rectilinear pixel array in real time.

The success of the CRT is directly attributable to the simplicity of its scan-addressing technique used to generate the raster or Lissajous patterns. Scan addressing is possible because of highly efficient, fast-responding cathodoluminescent phosphors. Scan addressing is further unique and ideal in that it can directly accept data in real time at video speeds from a single serial data channel without the need for intermediate data storage or shift registers.

In flat-panel displays, the addressing problem is similar in many ways to that in randomly addressable digital memories and solid-state imaging devices. The cross-coupling anomaly of a partial selection of nonselected pixels is identical. However, with displays the array must be of a size appropriate for viewing. It must be planar, with the proper linearity, size, shape, and percent active area. The viewing signal-to-noise ratio and power must be appropriate for human interpretation. There is no opportunity for noise filtering or error correction once the information is displayed.

All electronic displays are addressed by one of five basic techniques as summarized in Table 1-4. Normally, power is applied at the same time the pixels are addressed. In some flat-panel displays, the information is applied by one addressing scheme and the power is applied by another. The pixels in the array must effectively have three or four electrical leads when information and power are applied separately.

Addressing becomes more and more difficult as the number of pixels in the array becomes larger and larger. A successful addressing solution for an array of 64 rows by 128 columns may not work at all for an array of 128 rows by 128 columns using the same display media. The

reason for this is that the requirements of discrimination ratio (nonlinearity), speed of response, duty factor, dwell time, and power increase in proportion to the number of rows in the array. Typically, one axis is used for timing and the other is used for data input. It does not matter which one is used for which, except that there is some economy in the overall device if the smaller of the two is used for timing. For purposes of this book, the timing axis lines are called the rows and the data axis lines are called the columns. The addressing techniques are discussed in more detail in Chap. 5.

1.8.1 Direct Addressing. Direct addressing applies to the hard wiring of each pixel to a driver amplifier. It is only used with discretely and a few alphanumeric characters. Direct addressing becomes unacceptable for five or more numeric character displays. For example, for five seven-segment numeric displays with decimal, direct addressing would require 40 leads plus power return (8 for the seven segments plus decimal times 5 characters). If an integrated circuit were used to drive the display, 40 pins in the package would be dedicated to drive the display which greatly impacts the cost of the integrated circuit. Additional pins would be required for data-in, clock, and power. With matrix addressing, the number of leads could be reduced to 8 for the seven segments and decimal plus 5 for the five characters, making 8 column lines plus 5 row lines for a total of 13 leads. The array can be visualized as five rows and eight columns, and would be wired accordingly for matrix addressing. Direct addressing is sometimes used on large signs where there is adequate space and large amounts of power are required.

1.8.2 Scan Addressing. The addressing problem can best be understood by studying an array of pixels such as would be required for a commercial TV picture. There are approximately 480 rows (controlled by the raster sync signals) and 320 columns (limited by the video amplifier bandwidth) for a total of 153,600 usable addressable pixels in NTSC standard TV. To use an individual lead as in the direct-addressing technique would require 153,600 leads. This is virtually impossible except for a direct-view display the size of a billboard. Also, the

Table 1-4 Classification of All Known Addressing Techniques

Addressing Technique Name	Typical Pixel Electrode	Number of Amplifiers	Display Applications
Direct	One lead to each pixel with a common signal return for power or a pair of leads to each pixel	Number of rows multiplied by the number of columns	Four or fewer alphanumeric characters
Scan	Each pixel defined by beam size focused on continuous screen of pixel media	One for horizontal scan deflection; one for vertical scan deflection; one for beam intensity control	Cathode-ray tube and some flat CRT's
Grid	Each pixel defined by the grid hole geometry; one to four grids typically	Variable, dependent upon number of grids and subdivision of each grid but fewer than in matrix addressing	Vacuum fluorescence, some flat CRT's, and some gas discharge techniques
Shift	Each pixel electrically connected between one row channel and a pair of column leads	Number of rows plus number of columns divided typically by four for shift articulation (assume shift is along the rows only)	Uniquely used with some gas discharge and plasma panels
Matrix	Each pixel electronically connected between one row lead and one column lead	Number of rows plus number of columns	Possible with all flat-panel technologies with high discrimination ratio (large nonlinearity)

cost of completing all the connections, routing all the wires, and assembling all the amplifiers is prohibitive. The best technique is scan addressing, which unfortunately adds depth to the display. Scan addressing is uniquely integral to the CRT and to date has not been successfully applied to a flat-panel display except in flat CRTs.

1.8.3 Grid Addressing. The number of line drivers in matrix-addressing display arrays is a significant cost factor. Grid addressing is used to reduce the number of line drivers even further at the cost of increasing the physical structural complexity. The grids must all be electroded and constructed with holes. The display media need not possess a nonlinearity when grid addressing is used. However, the media must be sensitive to charged particles which can be controlled with a grid, such as gas discharge priming particles, electrons, or ions. Grid addressing does not have the partial-selection problem that matrix addressing has. Each grid effectively adds another electrode to each pixel. However, the array must be addressed pixel-at-a-time or row-at-a-time to prevent direct

cross-coupling as with matrix addressing. The name "grid" is used because the grid structure function is analogous to the grid of a triode vacuum tube.

1.8.4 Shift Addressing. Another way to reduce the number of line drivers even further is with the shift-addressing technique. Typically, the data are introduced in parallel in all the columns of one row at the left side of the display and shifted to the right. The gas-discharge-controlled switching characteristics are particularly suited for this approach. It is not the nonlinearity but the gas switching or priming properties that permit shifting of the input information. Channels may be constructed along each column to contain the discharge and prevent column-to-column crosstalk. After a gas discharge has been started in a gas-filled column channel, priming particles drift and diffuse along the column (data) channel to the next row (timing), lowering its firing voltage. When the scanning voltage is applied to a row, the pixel that has been primed turns on, and the pixel that has not been primed remains off. In this manner, the gas discharge can be articu-

lated along the channel by means of four interlaced and interconnected row-line drivers. With the shift-addressing technique, additional time is needed to shift the data into the display. Minimizing columns saves on the number of amplifiers—minimizing rows saves addressing time. Here the rows run vertically and the columns run horizontally.

1.8.5 Matrix Addressing. Matrix addressing is the most commonly used method for flat-panel displays. In comparison with direct addressing, the number of leads is reduced from the product of the number of rows and columns to the sum of the number of rows and columns. The overall physical construction is quite simple. However, the display media must possess a strong nonlinear characteristic to prevent partial selection of the nonaddressed pixels, and the array must be addressed pixel-at-a-time or line-at-a-time to prevent direct cross-coupling. Examples of display media that inherently possess a strong nonlinearity found to be most suitable for matrix addressing are light-emitting diodes, ac thin-film electroluminescence, and gas discharge.

If the media does not inherently possess sufficient intrinsic nonlinearity, as for example with liquid crystallinity and electrochromism, active electronic components must be added at each pixel. This has been successfully accomplished using transistors and/or diodes. However, complexity has now been added at each pixel. The necessary nonlinearity has also been achieved by introducing another material such as nonlinear resistor films of ZnO or ferroelectric wafers to act in concert with the display media to render a net nonlinear response. Mild nonlinear characteristics are realizable with liquid-crystal materials, permitting matrix addressing for small arrays.

When something is added to the display media to achieve matrix addressability, it provides "extrinsic matrix addressing." Otherwise it is simply matrix addressing or intrinsic matrix addressing. The adjectives "extrinsic" and "intrinsic" are analogous to extrinsic and intrinsic semiconductor materials. An extrinsic semiconductor is one where a dopant has been added to get the desired semiconductor properties. An intrinsic semiconductor inherently has the desired properties without adding a dopant.

1.9 DISPLAY DEVICE DEVELOPMENT

Display device development requires a sustained effort of advanced technical talent over an extended period of time. The effort requires the appropriate balance of research, engineering, manufacturing, marketing, finance, and management. A single organization with a grasp of the total technical problem, the stability for a prolonged development cycle, and the proper blend of corporate functions is indeed rare.

Moreover, a display is only a component. Production orders for displays come only after production of the product using the display has been committed to. After the display prototype is released for product application, it takes three years at a minimum until production quantities are ordered. The reasons for this are imbedded in corporate annual planning and budgeting procedures. There are three phases in new-product development, each of which takes a significant increase in commitment of company resources and financial support. The first year or phase is spent by the company, or organization responsible for the product, in evaluating the display and designing the product and making breadboards of the product or critical parts of the product. The second year or phase is spent making several engineering prototypes meeting functional requirements and evaluating them internally. The third year or phase is spent making pilot line units to form, fit, and function for limited sales and evaluation by product customers and users, planning production, and making marketing evaluations for production recommendations. Production could commence the fourth year. The production order for the display component comes only after the commitment to production and sales have been made.

The three-or-more-year delay from display prototype delivery to receipt of production order is a real negative aspect in any business plan for display development or in any present-value analysis or return-on-investment analysis. If a large investment is needed during the display prototype phase, the aspect of not getting production orders until three years after the first prototypes are delivered turns most investors away to greener pastures.

The development of a new display technology is often very long and financially and technically

Display pheno

Prototype

Testing of prot

Pilot plant

Production

hazardous. It usually r
years from the time of t
demonstration of an alp
small array to the begini
One institution may do b
a second may pick it up
effort in hopes of enter
then a third may contin
because it has a product
good development occur
reasons. Most frequentl
does not initially grasp t
the technical problems
cost and risk. As a con
ment up and schedule
the lack of internal man
cases of truncated devel
in corporate management
porate objectives, neces
key technical personnel
technical problems, lack
your market timing, or
present value analysis.

Frequently, a resear
new twist, or more likely
He demonstrates it to ma
some seed money. The i
clear and simple: "It co
appropriate for a wristw
which are sold per year)
of which are sold per
sustained by additional
customers, and perhaps
A patent is issued, and
at a technical conference
Quanta of individual

sequence. When this signal is synchronized with the addressing timing signal, the exact row and column location of the light pen is known, assuming pixel-at-a-time addressing. This technique is used with raster-addressed CRTs.

Coupling through the display may be done with a light pen. The light pen emits UV at the appropriate wavelength which can be made to trigger the operation of pixels which had been excited up to just below operating threshold. This has been demonstrated with EL and GD displays. The electronics detect the extra current that flows in the corresponding row and column lines due to the new operating pixel.

2.6.4 Electronics. The electronics are generally organized into several parts, as shown in Fig. 2-6, all dedicated to the operation of the display. The electronics contribute a larger share to the cost of the display system than does the display panel. Because of the numbers and power involved, the set of row and column line drivers is the largest cost element.

The heart of the electronic drive is the processor or microprocessor which is programmed to manipulate the data bus, buffer, and memory. The timing circuit is used to generate a basic clock signal for all the display operations and synchronize the enabling of the row drivers. The memory is used to hold the data in coded alphanumeric form or in pixel-bit map form. The data format converts the data out of the memory and prepares it in parallel form with the proper timing for the column drivers. The buffer interfaces the memory to the data line and strips out any synchronization signal. The row and column drivers apply a voltage to the display row and column electrodes.

This description is for a matrix-addressed panel display. Variations are used for other types of addressing. For large panels with 512 by 512 lines, the electronic drive will require 16 MOS chips where each chip can drive 64 lines. For small displays such as eight-digit numerics, it may all be done in one custom LSI circuit in one MOS chip.

In general, matrix-addressed displays have a

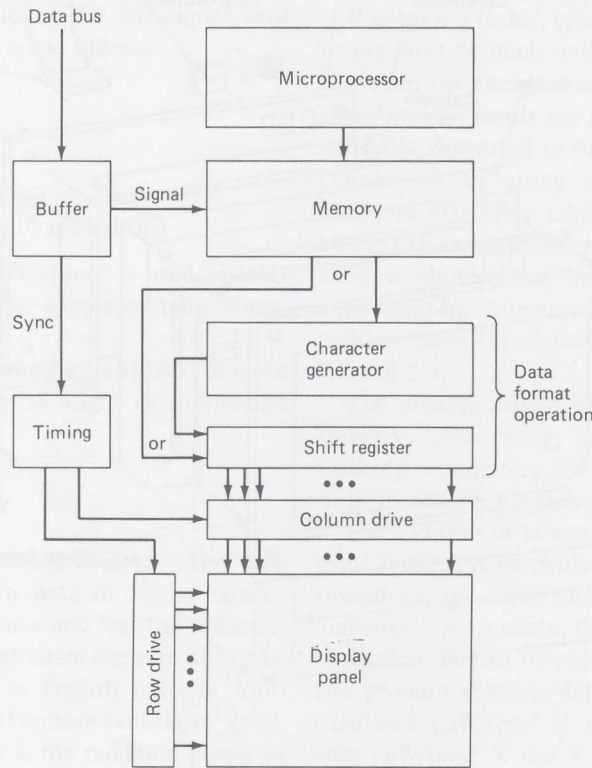

Fig. 2-6. Electronics for control and drive of displays.

large number of row and column lines which require a large number of pinouts, one for each line. This necessitates a large number of leads between the drive electronics and the display panel which in turn dictates the mounting of the display drivers next to the display panel as shown in Fig. 2-7. A small wiring harness is then used to connect this assembly to the remainder of the electronics.

The connection of all the drivers to all the row and column lines presents an electronic packaging problem which has been solved by one of several approaches, each of which is expensive and cumbersome. One technique is to simply mount the driver chips right on the display and seal them with the display. This technique makes repair and rework very difficult. A second approach is to mount the driver chips in a conventional package, solder the package

to a flexible polyimide-type cable with the appropriately etched circuit fanout which registers with the display panel electrical leads, and attach the polyimide flexible circuit to the display panel by soldering or spring-clamping. A third approach is to use an elastomeric connector to connect a conventional circuitboard with drivers to the display panel. The circuitboard is aligned and pressed against the display panel with the elastomeric connector in between.

The elastomeric connector is made of conductive layers of carbon or silver-impregnated polymer separated by layers of dielectric polymer on approximately 5 mil (127 μm) centers. The conductive layers are arranged to be parallel with the electric leads on the display panel and circuitboard with the conductive plane perpendicular to the surface. The metal on elastomer (MOE) connector performs in the same

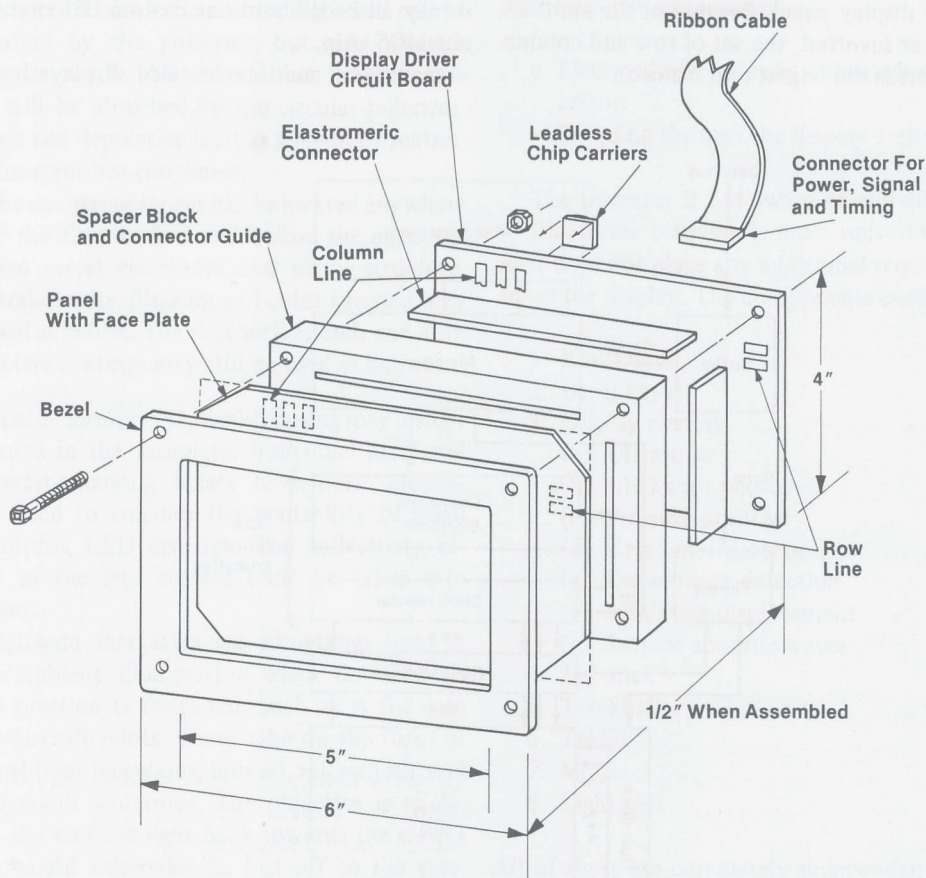

Fig. 2-7. Exploded view of display assembly.

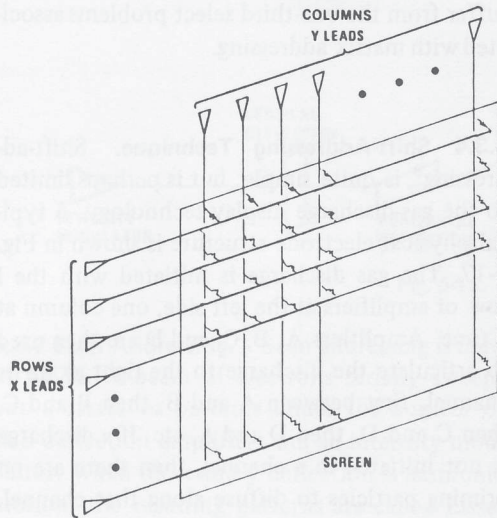

Fig. 5-18. Matrix addressing.

electrodes will not skip to the next AB electrodes, because the priming particles cannot diffuse that far down the channel before they recombine. The priming particles are physically blocked from diffusing from one row to the next. The role and nature of the priming particle is discussed in Chap. 10.

The shift-addressing technique uses fewer amplifiers than the matrix-addressing technique. It is simple in construction and ideally suited to small-to-medium-size numeric gas-discharge displays. Time is required to shift the image into the display. Except in scroll mode, the image cannot be read while it is being written, as it can with matrix addressing. In the scroll mode, the data is shifted in slowly. Scrolling of data is ideal for such applications as tickertape data.

The Self-Scan™ display, formerly manufactured by Burroughs, uses the shift technique to enable each column, and the grid technique to activate each row. The Self-Scan™ and other gas-discharge configurations using these basic techniques are discussed in Chap. 10.

5.3.5 Matrix Addressing. The simplest display panel structure in flat-panel displays has been achieved using the matrix technique. The essence of the matrix-addressing structure is a set of electrically isolated leads arranged orthogonally, with a pixel at each intersection. The horizontal set is called the *rows* and the vertical set is called the *columns*, as shown in Fig. 5-18. A typical

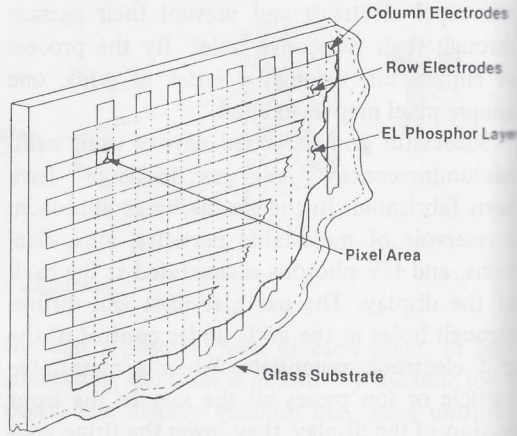

Fig. 5-19. Typical flat-panel display construction.

matrix-addressed display structure is shown in Fig. 5-19. This particular structure is used in electroluminescent displays where the medium is a phosphor.

One-Third-Select. A major difficulty with matrix addressing is the sneak circuit, which causes a voltage to be applied across all the pixels when only one is addressed.^{9, 10, 11} This phenomenon will be called *one-third-select* for reasons which will become apparent later. An equivalent circuit for the matrix-addressed display is shown in Fig. 5-20. The display material electrical impedance is schematically shown as a resistor. The impedance may be linear or any conceivable form of nonlinearity such as hysteresis, diode, or threshold effect. The voltage drop across each pixel in the array can be computed from Kirchhoff's Voltage and Current Laws for solving electrical network problems.

Before proceeding, it will be appropriate to briefly review Kirchhoff's Laws.¹² The Voltage Law, simply stated, is that the sum of the instantaneous voltage drops around any closed loop of branches from node to node is equal to zero. The Current Law, simply stated, is that the sum of the current into any node is zero. In Fig. 5-21, the nodes are a, b, c, d, and e, and the branches are 1, 2, 3, 4, 5, 6, 7, and 8. The arrows are arbitrarily assigned to define the polarity. The voltage drop between nodes a and b is V_1 . If voltage V_1 is equal to a positive numerical value, then V_a is more positive than V_b . Furthermore, the current flow is positive in each branch when

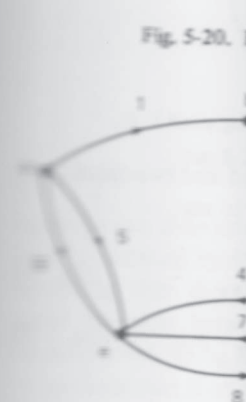

Fig. 5-21. Electric

flows in the direction
 circuit elements of a p
 mesh. The node corr
 vertical or display line.
 Example voltage and

Loop 1, 2, 3, 7, 5, (1)

$$V_1 + V_2 + V_3 + V_7 - V_5 = 0$$

Loop 4, 3, (4)

$$V_4 - V_3 = 0$$

Node b

$$V_4 + V_8 = 0$$

Node c

$$I_1 - I_2 = 0$$

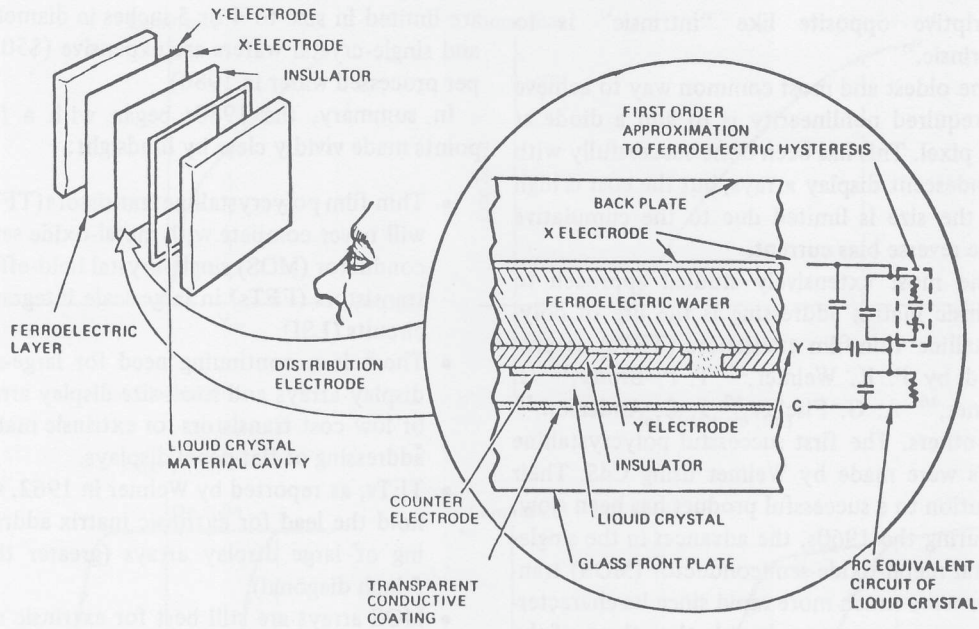

Fig. 5-27. LC/PLZT extrinsic matrix-addressing technique.¹¹

balance of the frame time. The slow speed of response of LC material (30 to 100 ms) is of no consequence in this type of addressing. The display exhibits neither smear nor flicker at 30 frames per second, even for the faster responding LC materials.

5.4 DUTY FACTOR

There are two types of duty factors of interest to the display designer and user:

- Addressing duty factor
- Pixel dwell time

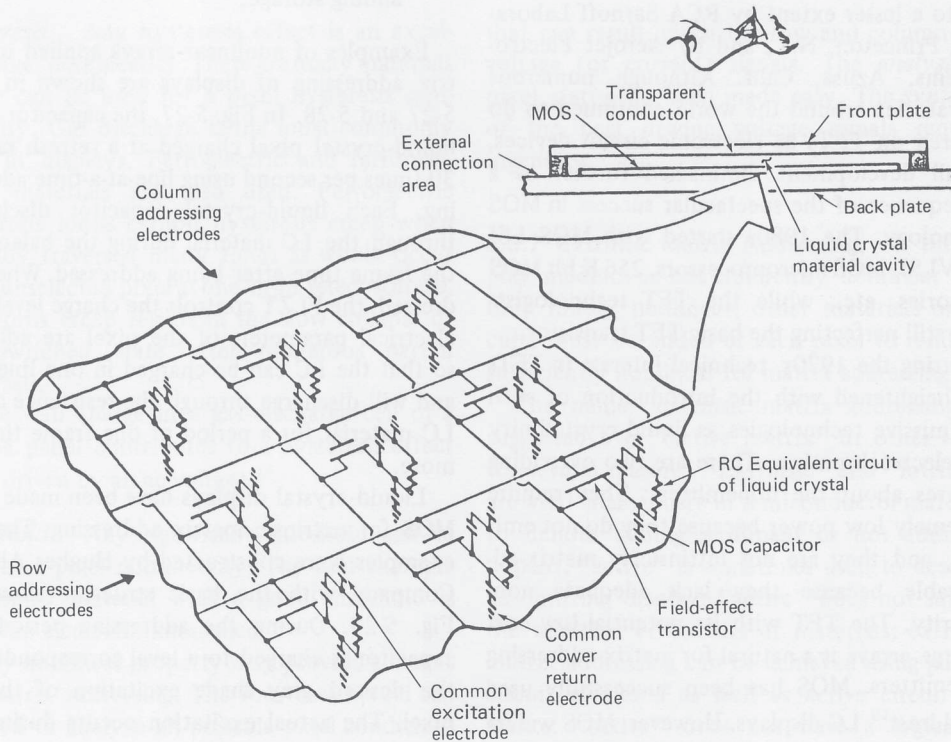

Fig. 5-28. LC/MOS extrinsic matrix-addressing technique.

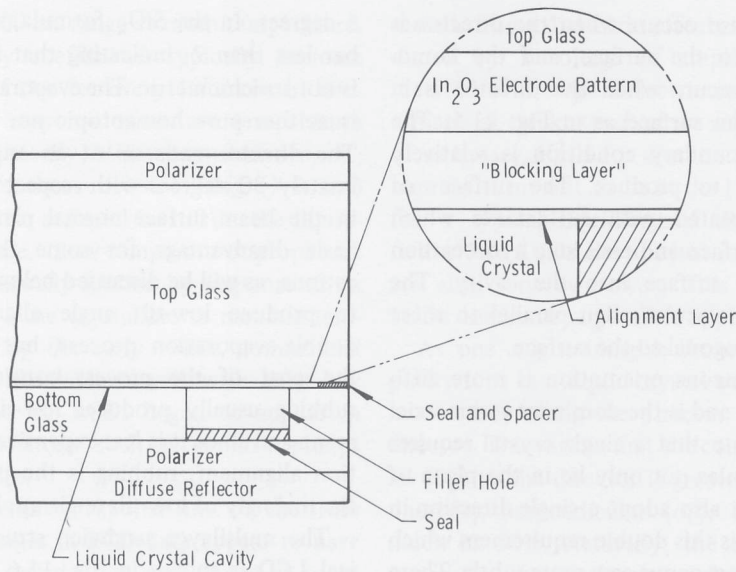

Fig. 11-6. LCD Cross Section: The liquid crystal is contained as the center of a multilayer sandwich. The glass substrates are coated on the interior side with In_2O_3 transparent electrodes to apply local electric fields (see blow-up of liquid-crystal cavity). A dielectric (blocking) layer and an alignment layer are present on both interior substrate surfaces. Polarizers and a reflector complete the planar structure with perimeter and fill hole seals indicated.

cesses will not produce good alignment after exposure to these temperatures, but SiO_x evaporation will work. Thus, most displays made with frit seals have SiO_x alignment, while epoxy seals usually mean rubbing alignment.

In the early 1970s there was considerable disagreement over which type of process was adequate for consumer products. Since then, more stable liquid-crystal materials have become available, e.g., biphenyls, cyclohexanes, and esters, permitting reasonable life in epoxy-sealed packages. Since the rubbing alignment/epoxy seal is cheaper, and is capable of multiplex address, it has become the standard LCD fabrication technique for watch/calculator/game applications. Displays exposed to more severe temperature/humidity environments (e.g., for automobiles) may still require the hermetic seal of the frit/evaporated alignment process.

11.3 LCD CONFIGURATIONS

Although the electro-optic effect shown in Fig. 11-5 constitutes a display, it is not a high-quality one. The molecular reorientation, in conjunction with external polarizers, produces interference colors through the mechanism out-

lined in Section 11.1.1. Interference colors are not high-contrast, however, and the colors are not saturated. The design of Fig. 11-5 is not commercially viable. During the late 1960s and early 1970s several new display geometries were invented. The dynamic scattering mode (DSM), the dichroic dye mode, the cholesteric/nematic display, the twisted nematic mode, the fluorescence-activated display (FLAD), the smectic LCD, and disclination LCDs will be discussed. The majority of the discussion will center on the twisted nematic mode since it is the dominant technology at present.

11.3.1 Dynamic Scattering LCD. Dynamic scattering was invented by Heilmeyer, Zanoni, and Barton and was announced in 1968.³ The display operates by scattering light at dislocations in a turbulent structure. The precursor of the turbulent structure is shown in cross section in Fig. 11-7. Note the domain pattern as opposed to the uniform distortion in Fig. 11-5. The domains are not especially strong scatterers, but at higher voltages dislocations in the pattern produce much stronger scattering. Unfortunately, the scattering is at small angles, i.e.,

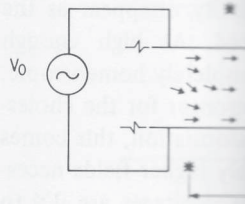

Fig. 11-7. Dynamic Scattering LCD: Dynamic scattering is shown. Distortion of wavelength domain lines above and below pattern is accompanied by vortices.

forward scattering. They have wide-angle (large) sources of light are scattered. For a comparison of dynamic scattering display see Table 11-1. This relates to the fact that it is restricted to greater angles for technical reasons. Visible light is smaller than this and therefore scattered at large angles.

The physics behind this is indicated than for the other modes in the dielectric/elastic mode. The DSM mostly occurs in a turbulent structure. The dielectric anisotropy in the field, one expects that the molecules align perpendicular to the electric field. In a homogeneous boundary condition, there is no dielectric torque to align the molecules to the electrode plane. This is therefore unexpected. This is not possible for the model which Heilmeyer showed how vortices

Display
TN/LCD
DSM/LCD
DYE/LCD
ECD
EPD
*Measure

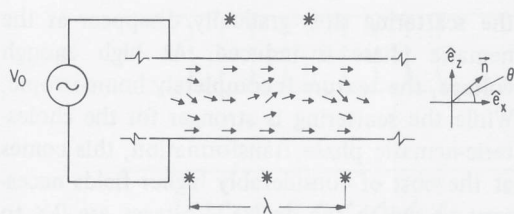

Fig. 11-7. Dynamic Scattering Mode: The time-independent liquid-crystal structure which precedes dynamic scattering is shown in cross section. A periodic distortion of wavelength refracts light into a series of domain lines above and below the sample. The director pattern is accompanied by an array of antiparallel vortices.

forward scattering. The display does not have wide-angle (large-aperture) viewing when the sources of light are restricted to a few directions. For a comparison of the PCR and DBR of dynamic scattering displays with other displays, see Table 11-1. The small-angle scattering relates to the fact that the liquid-crystal cavity is restricted to greater than 6 to 8 μm for practical reasons. Visible light has wavelengths much smaller than this and therefore cannot be scattered at large angles.

The physics behind the DSM is more complicated than for the other displays which operate in the dielectric/elastic fashion discussed earlier. The DSM mostly occurs in materials with negative dielectric anisotropy. In an applied electric field, one expects that the director will tend to align perpendicular to the field. For the homogeneous boundary condition in Fig. 11-7, there is no dielectric torque to tilt the director out of the electrode plane. The domain structure is therefore unexpected. Helfrich¹¹ was responsible for the model which explains this mode. He showed how vortex flow in the sample

could be set up by space charge produced by the applied electric field. The shear rates involved in the vortex motion produce a torque on the director via the shear torque interaction described above. The sign of the torque is such that the distortion grows above a threshold voltage. This leads to more space charge which leads to larger shear rates, etc., until nonlinearities limit the growth. The period of the distortion can be explained by rigorously solving the two-dimensional boundary value problem.¹²

Dynamic scattering has a threshold voltage of approximately 6 V and operates well at voltages over 10 V. Space charge is essential to the device, and the pure liquid is doped with ionic salts to provide the conductivity. Since the voltage and current requirements are larger for the DSM than for the field effect in Fig. 11-5, the power necessary to operate DSM is two orders of magnitude greater than for a field effect.

11.3.2 Dichroic Dye LCD. In 1968 the workers at RCA announced another liquid-crystal display, the dichroic dye display.⁴ This is an absorbing rather than a scattering mode. It takes advantage of the fact that dye molecules will align parallel to the director when dissolved in a liquid crystal. Thus, the name guest-host display has also been used. For this display to work, the dye must be dichroic. The absorption coefficient of the dye depends on whether the electric field of the incident light is aligned parallel or perpendicular to the long axis of the dye. Typically, the absorption constant parallel to the axis is much greater than the perpendicular constant. Consider the liquid-crystal orientation of Fig. 11-5 with a dye dissolved in the liquid crystal. In the off state, the dye

Table 11-1. Non-emitting Display Comparison

Display	PCR*	DBR*	Angle Dependence	V_{on}	Power or Charge/cm ²
TN/LCD	6-8	0.25	Significant	3 VRMS	0.5 μW
DSM/LCD	5	0.5	Very significant	12 VRMS	10.0 μW
DYE/LCD	4	0.5	Small	10 VRMS	2.0 μW
ECD	5	0.8	Small	2 V dc	5.0 mC
EPD	5	0.65	Small	50 V dc	0.1 μC

*Measured at best viewing angle, typical data for room ambients.

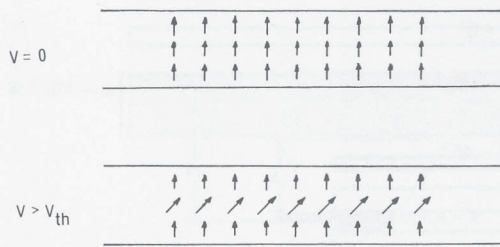

Fig. 11-8. DAP Field Effect: The DAP geometry is shown in cross section. The initial homeotropic alignment is distorted into a uniform bend pattern by the electric field/negative dielectric anisotropy torque.

materials. When the sample is placed between crossed polarizers, it does not transmit light in the off state. When the voltage is applied, the molecules tilt and light is transmitted. Unfortunately, this does not work out to be a high-contrast display when viewed in reflection in ambient light. If the display is viewed in transmission with collimated light, i.e., a very narrow viewing angle, a more satisfactory display is produced. The electro-optic threshold characteristics of the DAP effect tends to be very sharp, and this has important flat-panel advantages as will be discussed below.

11.3.5 Twisted Nematic LCD. In 1970 two groups,^{5,6} independently developed a two-polarizer display which has become the overwhelming success in LCD technology. As the name twisted nematic implies, the display geometry produces a 90-degree twist in a nematic material, as shown in Fig. 11-9. The twist results from homogeneous boundary conditions on the two surfaces being oriented at 90 degrees to each other. The electromagnetic modes of this inhomogeneous birefringent material are quite complex. For a particular twist pitch and birefringence range, however, visible light is transmitted through the material in a unique manner. If the light is incident on the sample polarized either parallel or perpendicular to the director at the surface, the light is rotated 90 degrees and emerges plane-polarized from the opposite side. The reader is warned that this is a unique behavior and does not yield to typical birefringent analysis. The key is that the birefringent axis is constantly changing in space.

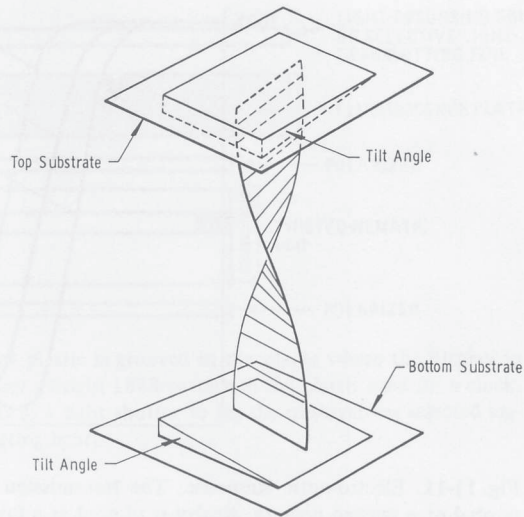

Fig. 11-9. The Twist Structure: The twisted nematic structure is produced by surface alignment layers being twisted by 90 degrees with respect to each other. The director pattern is a uniformly twisted structure as shown. This give rise to a twisted birefringent material—a structure unique to liquid crystals. The alignment is homogeneous with a slight tilt to insure that the molecules all turn in the same direction above threshold.

The display contains crossed polarizers which are aligned with the alignment axis (see Fig. 11-10). Ambient light incident on the display is polarized by the first polarizer and then is twisted 90 degrees by the twisted nematic.

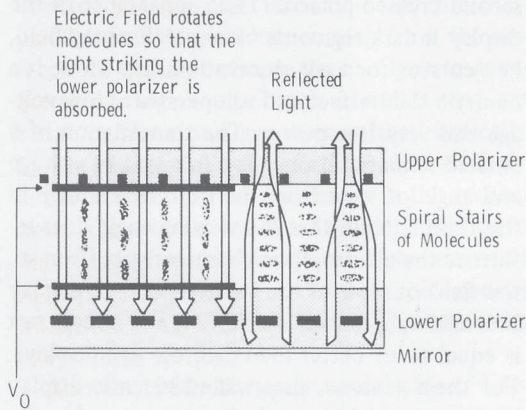

Fig. 11-10. The Twisted Nematic LCD: The result of the twisted nematic structure combined with crossed polarizers is shown in cross section. In the field-free region, the polarized light incident on the liquid crystal is twisted to a gray off state. Where the voltage is over threshold, the twist structure is destroyed. The initial polarized light is absorbed by the bottom polarizer, and the on state is dark.

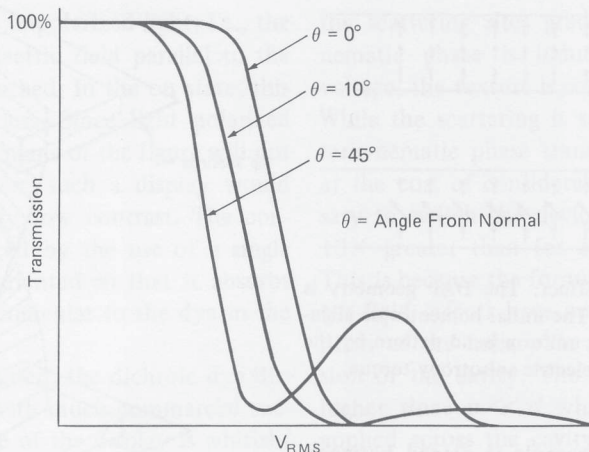

Fig. 11-11. Electro-optic Response: The transmission of a collimated light beam at an angle θ relative to the normal of a twisted nematic display is plotted as a function of the applied voltage. Note that the lowest voltage at which transmission begins to decrease for a given θ rises as θ decreases. This can be understood by realizing that the transmission is minimum in an angular region around the director orientation at the center of the cell. As the director tilts up, the transmission decreases at larger values of θ , (not same θ as in 11.5).

The light emerging from the liquid crystal is now incident on the second polarizer in an orientation such that the light is not absorbed. It travels to the mirror, is reflected, and passes again through the whole system with little attenuation. When a voltage is applied, the director tilts up, thereby undoing the twist structure. When the polarized light now propagates through the liquid crystal, it is not twisted and therefore is absorbed by the second crossed polarizer. The appearance of the display is dark segments on a metallic gray field, i.e., correct for easy observation. The mode is a nematic field effect and so operates at low voltage and very low power. The transmission of a twisted nematic display as a function of voltage and angle of view from the normal is shown in Fig. 11-11. Note that the viewing angle does influence the electro-optic characteristic. Even so, the field of view of the twisted nematic display is considerably larger than DSM, and its contrast is equal to or better than dichroic dye displays. For these reasons, the twisted nematic display has found wide consumer acceptance and in the early 1980s was manufactured at running rates exceeding 10 M per month worldwide.

11.3.6 Fluorescent LCD. As useful as the twisted nematic LCD is, it is better described as functional rather than attractive. The loss in brightness associated with the polarizers gives a

generally dull appearance. One way to increase the apparent brightness of a display is to back-light it. In 1977 Baur and Greubel²⁰ announced a particularly ingenious method of collecting ambient light and directing it through a twisted nematic display. They called it the fluorescence-activated display (FLAD). A cross-section diagram of the display system is shown in Fig. 11-12. The twisted nematic part of the structure is similar to that in Fig. 11-10 with the exception that the polarizers are parallel rather than crossed. When the display is on, one sees through the activated segments to the fluorescent plastic behind the display. Since the plastic can be quite thin, the display system remains flat.

The key to the FLAD is the fluorescent dye contained in the plastic. The dye absorbs light in the blue end of the spectrum and re-emits the light at longer wavelengths. By using the right dye in the plastic, energy in the blue (where the eye is not sensitive) is converted into energy in the green or orange, where the eye is very sensitive. The re-emitted light is radiated uniformly over a 4π steradian solid angle, and so most gets trapped in the plastic light pipe. It travels to the end of the substrate or surface defects, where it escapes. This results in a large brightness gain. The effect is already used commercially in draftsmen's drawing triangles. In the FLAD application, the plastic is grooved to spoil the total in-

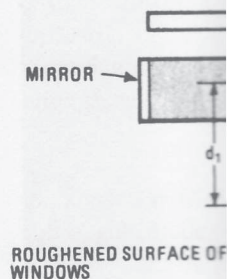

Fig. 11-12. Fluorescence front of the plastic is The twisted nematic elements of the 1888 pat

ternal reflection b Local "light" source light. When the dis green or orange gl light-emitting displ effective when vie between the plasti ments cuts down o

11.3.7 Smectic LC der present in sm higher viscosities times at reasonable liquid crystals. Thu tic displays driven 1973 Kahn²¹ disc crystal could be a nonscattering state pulse to raise the s at the pixel in qu cooled, it was sub align the molecule called for. If the texture, the elect display mode has and clear states o time. This memory tial for matrix ad below.

11.3.8 Disclination cussed above, mos for displays origina ture. In 1980, how that specifically to

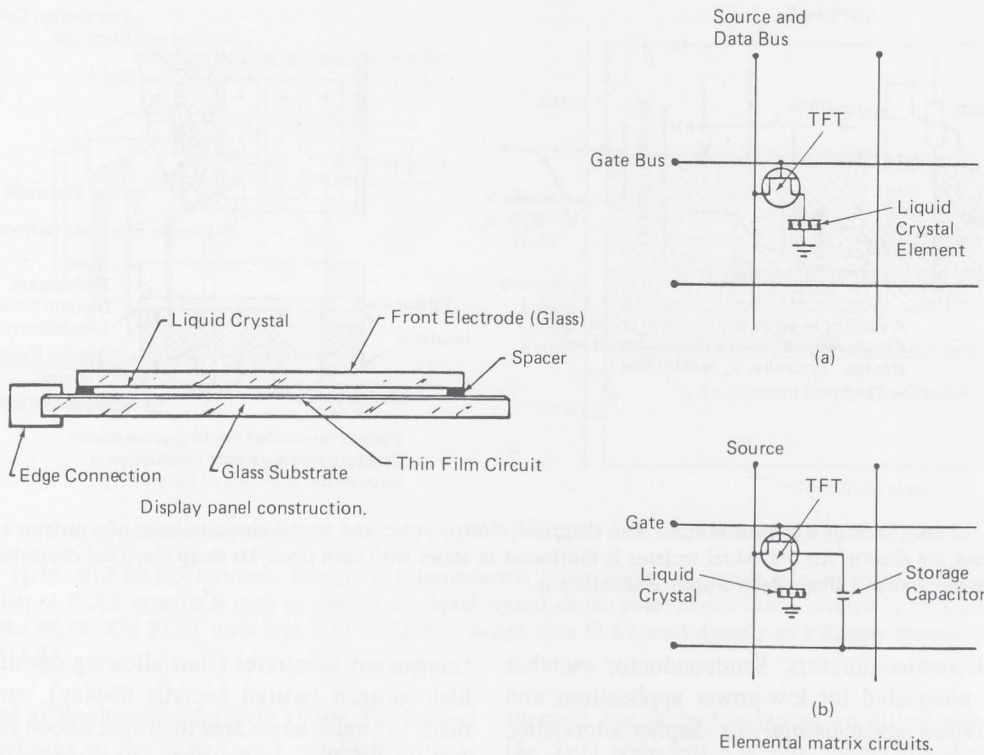

Fig. 11-17. Thin-Film Transistor Extrinsic Matrix: An array of transistors is fabricated on glass using thin film technology. The substrate is cheap, can be made “arbitrarily” large, and is transparent. Again, there is an active element for each pixel, and the x-y array addresses the transistors rather than the liquid crystal.

to be followed. Note that the ultimate TFT (or bulk silicon) display could include shift registers to address the $2N$ leads in the N^2 pixel array. This would mean a few interconnections to the display instead of the 500 or more connections needed for a standard x-y matrix. For very large information content at reasonable cost, this integration will be essential.

11.5.4 Bulk Silicon Addressing. The best understood semiconductor material is, of course, silicon. This makes the material a natural for active matrix addressing. There has been a great deal of work invested in R&D on this technology with outstanding technical success.⁵⁴⁻⁵⁷ The basic pixel memory element for bulk silicon and TFT devices are very similar, although the processing methods are obviously different. The details of both processes are, naturally, closely held secrets. It is reasonable to assume that the design rules for the MOS devices are different from standard LSI design rules. In display technology the silicon process must produce a very

high yield ($\geq 99.7\%$) of relatively simple transistor structures over an area the size of the whole slice. In LSI fabrication, very complex structures are fabricated, and low yields can often be tolerated due to the small size of the finished device and its high functionality.

The use of silicon as one substrate for a liquid-crystal display means that the display mode used cannot have a rear polarizer, e.g., dynamic scattering, or a dye display. It also means that large-area displays must be fabricated from a number of silicon slices which were at 100-mm size in standard production in the early 1980s. A picture of a video display built at Hughes is shown in Fig. 11-18. The 2.5-inch-diagonal display has 30,625 elements. The display can be run at video frame rates and, obviously, is approaching the resolution necessary for television (black-and-white). Defect-free devices have been reported using silicon transistors, while TFT devices are not as far advanced. Recently Matsushita⁵⁶ and Toshiba⁵⁷ have shown a prototype portable TV using the bulk silicon to address the dynamic

Fig. 11-18. Silicon Extrinsic circuitry is similar to the action is much better and limited in area. An e

scattering mode. Suw developed a portable dressing the dye mode has integrated shift registers bulk silicon array to interconnects to the $N \times N$ array.

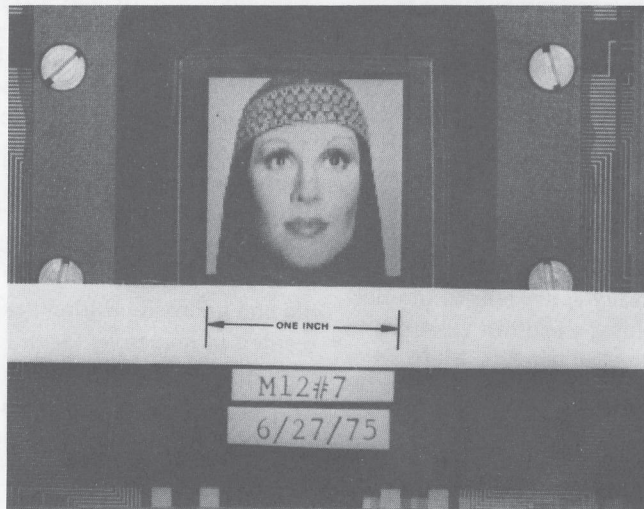
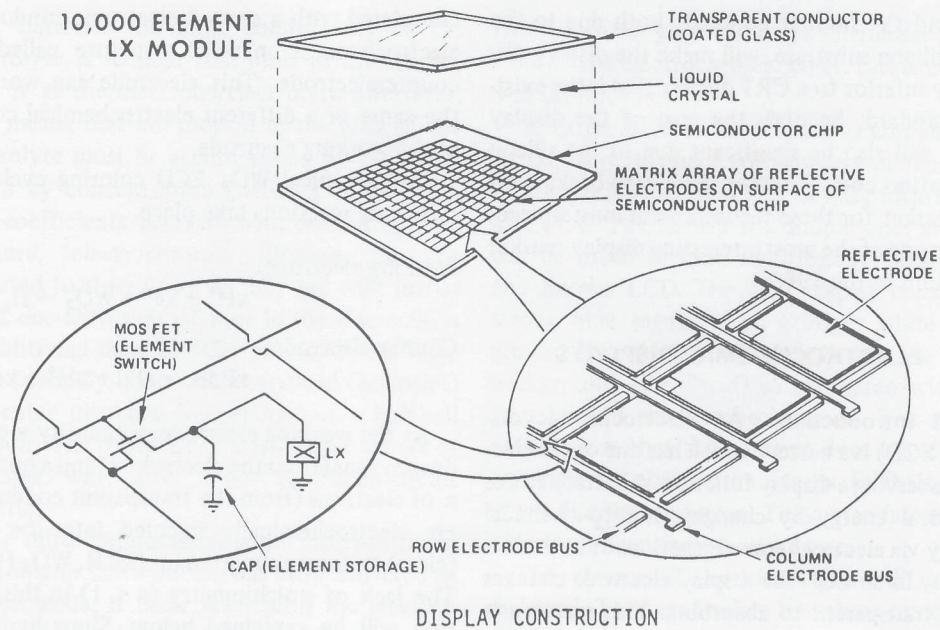

Fig. 11-18. Silicon Extrinsic Matrix: An array of transistors is fabricated on a single-crystal silicon wafer. The circuitry is similar to the TFT design with the liquid crystal in contact with the transistors. Silicon transistor action is much better understood and more reliable than TFT operation, but the substrate is opaque, expensive, and limited in area. An example of a picture displayed on a Hughes array is also shown. (John Gunther)

scattering mode. Suwa Seikosha⁵⁸ (Epson) has developed a portable TV with bulk silicon addressing the dye mode LCD. Daini Seikosha⁵⁹ has integrated shift registers on the edge of the bulk silicon array to solve the large number of interconnects to the $2N$ leads from a simple $N \times N$ array.

From the large amount of work going on with bulk silicon addressing of LCDs, especially in Japan, it is reasonable to forecast portable LCD TVs becoming available commercially in the mid 1980s. Whether they gain wide acceptance, however, depends on two problems this approach seems to have generically. First of all, the limited