



US006891258B1

(12) **United States Patent**
Alexander et al.

(10) **Patent No.:** US 6,891,258 B1
(45) **Date of Patent:** May 10, 2005

(54) **INTERPOSER PROVIDING LOW-INDUCTANCE DECOUPLING CAPACITANCE FOR A PACKAGED INTEGRATED CIRCUIT**

6,459,561 B1 10/2002 Galvagni et al.
6,477,032 B2 11/2002 Maki, Jr.
2002/0101702 A1 8/2002 Maki, Jr.
2003/0001287 A1 * 1/2003 Sathe 257/780
2003/0062602 A1 * 4/2003 Frutschy et al. 257/666

(75) Inventors: **Mark A. Alexander**, Boulder, CO (US); **Robert O. Conn**, Los Gatos, CA (US); **Steven J. Carey**, San Jose, CA (US)

* cited by examiner

Primary Examiner—Allan R. Wilson
Assistant Examiner—Joseph Nguyen
(74) *Attorney, Agent, or Firm*—Lois D. Cartier; LeRoy D. Maunu

(73) Assignee: **Xilinx, Inc.**, San Jose, CA (US)

(*) Notice: Subject to any disclaimer, the term of this patent is extended or adjusted under 35 U.S.C. 154(b) by 139 days.

(57) **ABSTRACT**

Structures that provide decoupling capacitance to packaged IC devices with reduced capacitor and via parasitic inductance. A capacitive interposer structure is physically interposed between the packaged IC and the PCB, thus eliminating the leads and vias that traverse the PCB in known structures. A capacitive interposer is mounted to a PCB and the packaged IC is mounted on the interposer. The interposer has an array of lands on an upper surface, to which the packaged IC is coupled, and an array of terminals on a lower surface, which are coupled to the PCB. Electrically conductive vias interconnect each land with an associated terminal on the opposite surface of the interposer. Within the interposer, layers of a conductive material alternate with layers of a dielectric material, thus forming parallel plate capacitors between adjacent dielectric layers. Each conductive layer is either electrically coupled to, or is electrically isolated from, each via.

(21) Appl. No.: **10/313,482**

(22) Filed: **Dec. 6, 2002**

(51) **Int. Cl.**⁷ **H01L 23/48**; H01L 23/34

(52) **U.S. Cl.** **257/678**; 257/738; 257/774; 257/777; 257/780; 257/737; 257/713; 257/722; 257/690; 257/691; 257/698; 257/699; 257/784

(58) **Field of Search** 257/738, 774, 257/777, 780, 737, 713, 722, 784, 690, 691, 698, 699

(56) **References Cited**

U.S. PATENT DOCUMENTS

5,880,925 A 3/1999 DuPre et al.
6,342,681 B1 1/2002 Goldberger et al.

53 Claims, 7 Drawing Sheets

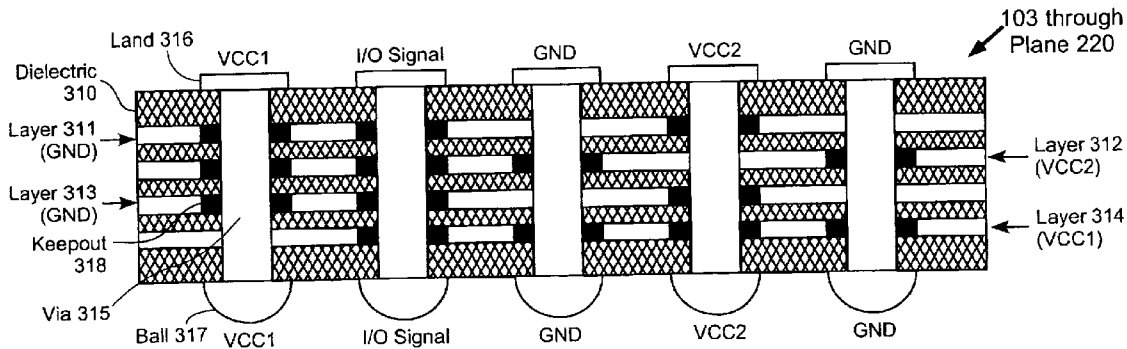

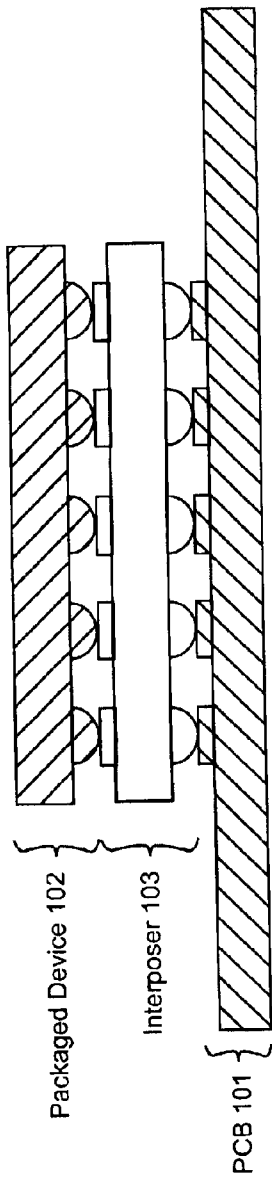

FIG. 1

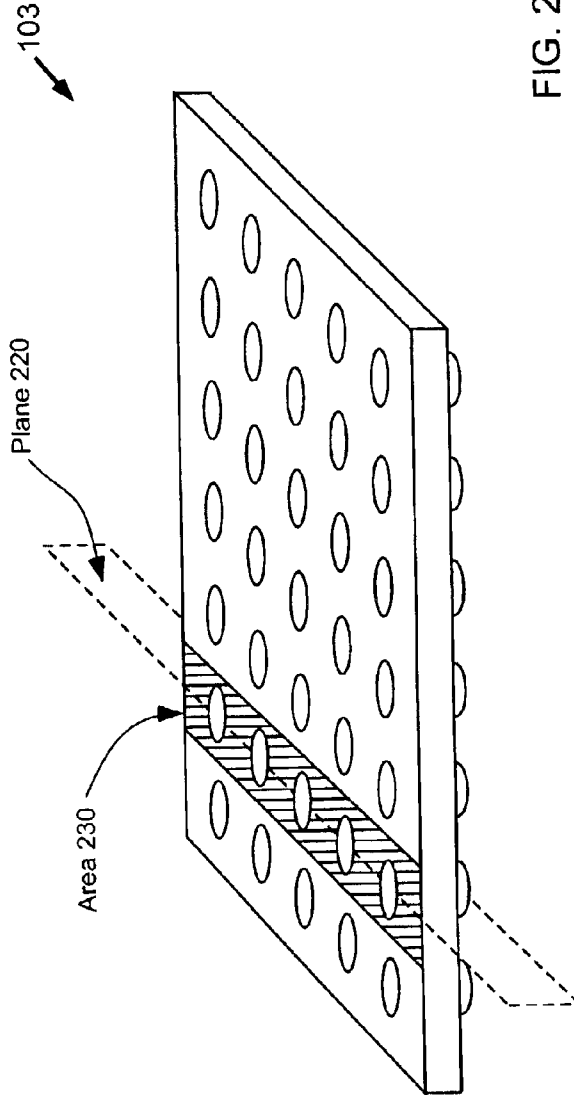

FIG. 2

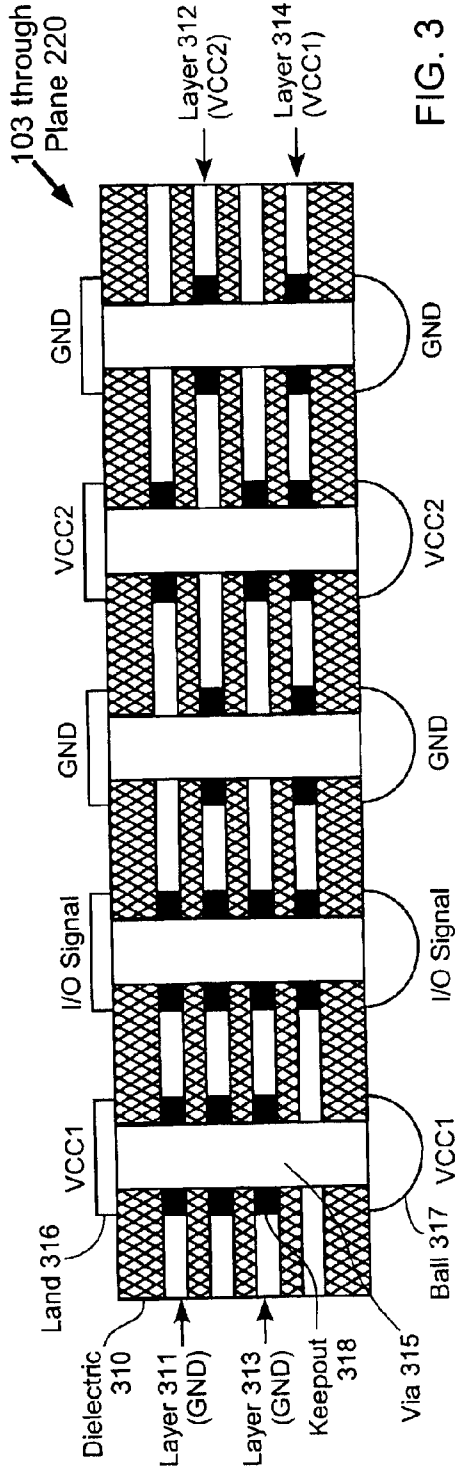

FIG. 3

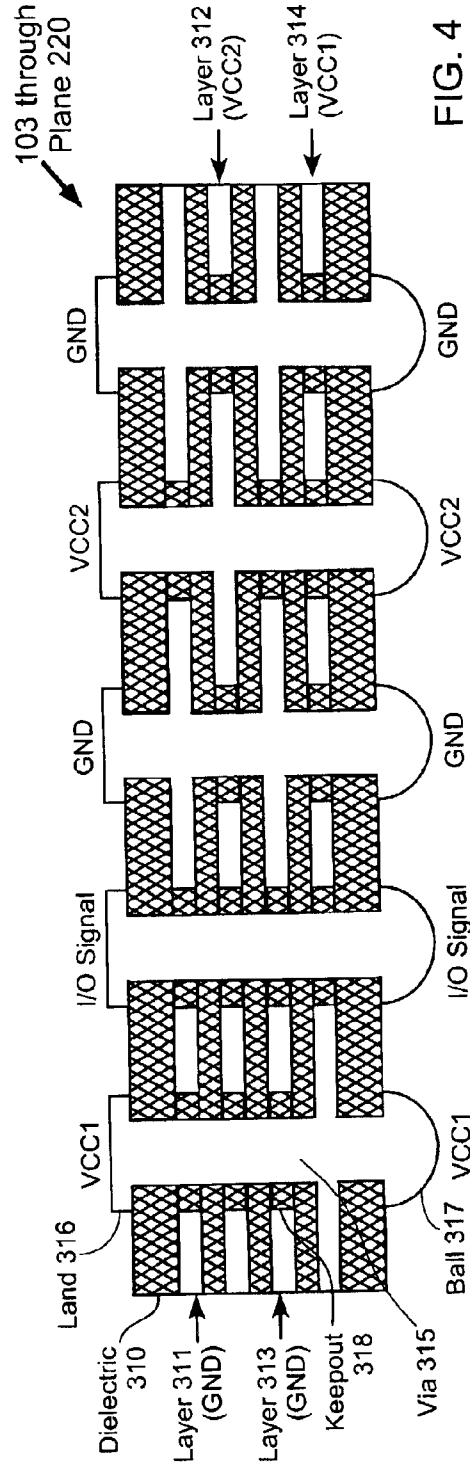
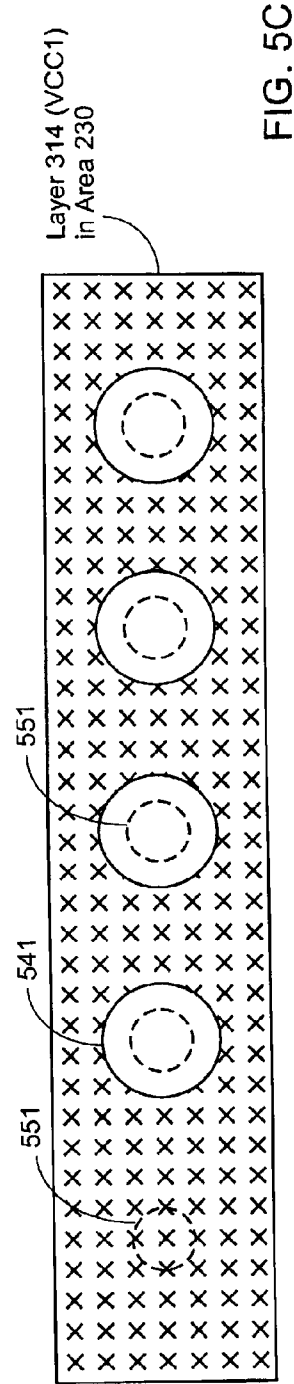
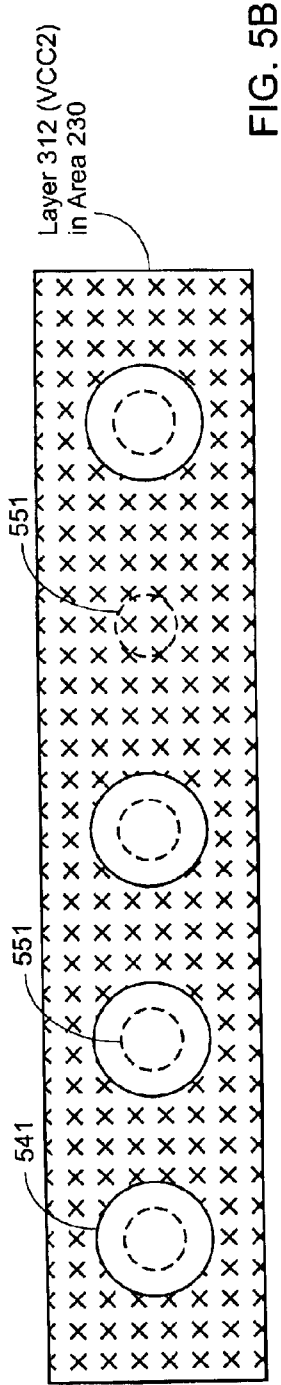
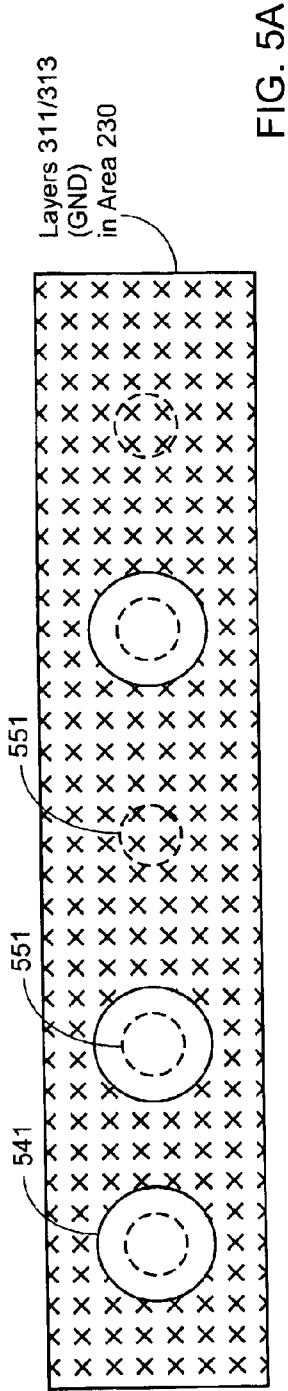

FIG. 4



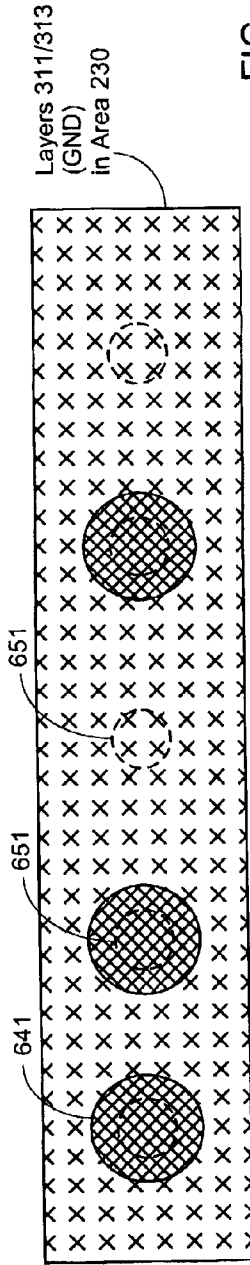

FIG. 6A

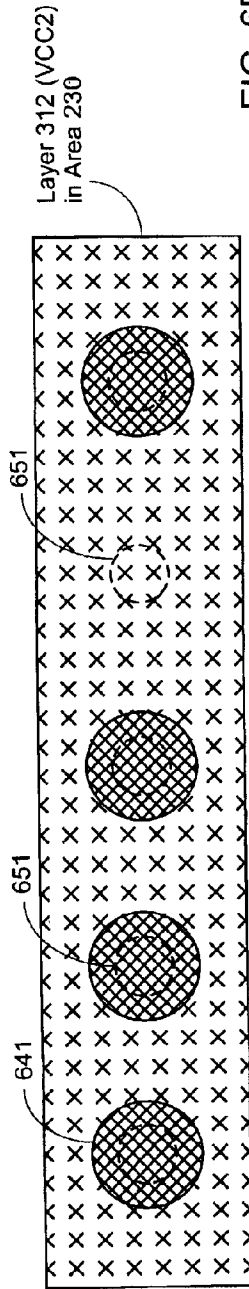

FIG. 6B

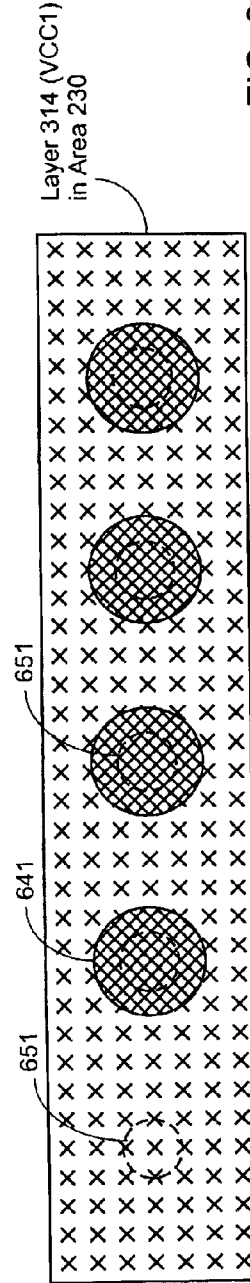

FIG. 6C

Explore Litigation Insights

Docket Alarm provides insights to develop a more informed litigation strategy and the peace of mind of knowing you're on top of things.

Real-Time Litigation Alerts



Keep your litigation team up-to-date with **real-time alerts** and advanced team management tools built for the enterprise, all while greatly reducing PACER spend.

Our comprehensive service means we can handle Federal, State, and Administrative courts across the country.

Advanced Docket Research



With over 230 million records, Docket Alarm's cloud-native docket research platform finds what other services can't. Coverage includes Federal, State, plus PTAB, TTAB, ITC and NLRB decisions, all in one place.

Identify arguments that have been successful in the past with full text, pinpoint searching. Link to case law cited within any court document via Fastcase.

Analytics At Your Fingertips



Learn what happened the last time a particular judge, opposing counsel or company faced cases similar to yours.

Advanced out-of-the-box PTAB and TTAB analytics are always at your fingertips.

API

Docket Alarm offers a powerful API (application programming interface) to developers that want to integrate case filings into their apps.

LAW FIRMS

Build custom dashboards for your attorneys and clients with live data direct from the court.

Automate many repetitive legal tasks like conflict checks, document management, and marketing.

FINANCIAL INSTITUTIONS

Litigation and bankruptcy checks for companies and debtors.

E-DISCOVERY AND LEGAL VENDORS

Sync your system to PACER to automate legal marketing.