



US008001055B2

(12) **United States Patent**  
**Weiss**

(10) **Patent No.:** **US 8,001,055 B2**  
(45) **Date of Patent:** **\*Aug. 16, 2011**

(54) **METHOD, SYSTEM AND APPARATUS FOR SECURE ACCESS, PAYMENT AND IDENTIFICATION**

5,097,505 A 3/1992 Weiss  
5,168,520 A 12/1992 Weiss  
5,237,614 A 8/1993 Weiss  
5,361,062 A 11/1994 Weiss  
5,367,572 A 11/1994 Weiss  
5,398,285 A 3/1995 Borgelt et al.

(76) Inventor: **Kenneth P. Weiss**, Newton, MA (US)

(Continued)

(\* ) Notice: Subject to any disclaimer, the term of this patent is extended or adjusted under 35 U.S.C. 154(b) by 596 days.

This patent is subject to a terminal disclaimer.

**FOREIGN PATENT DOCUMENTS**

EP 0986209 3/2000

(Continued)

(21) Appl. No.: **11/677,490**

**OTHER PUBLICATIONS**

(22) Filed: **Feb. 21, 2007**

“FIPS PUB 46-3.” Oct. 25, 1999. National Institute of Science and Technology (NIST). All pages.\*

(65) **Prior Publication Data**

(Continued)

US 2007/0198436 A1 Aug. 23, 2007

**Related U.S. Application Data**

*Primary Examiner* — Andrew J. Fischer  
*Assistant Examiner* — Calvin K Cheung  
(74) *Attorney, Agent, or Firm* — Lando & Anastasi, LLP

(60) Provisional application No. 60/775,046, filed on Feb. 21, 2006, provisional application No. 60/812,279, filed on Jun. 9, 2006, provisional application No. 60/859,235, filed on Nov. 15, 2006.

(51) **Int. Cl.**  
**G08Q 20/00** (2006.01)

(57) **ABSTRACT**

(52) **U.S. Cl.** ..... **705/76; 713/186; D14/480.4; 382/128; 382/129; 382/187**

According to one aspect, the invention provides a system for validating an identity of a user to enable or prevent an occurrence of an event. In one embodiment, the system includes a first device including a wireless transmitter which is configured to transmit validation information, a second device including a wireless receiver, where the second device is configured to receive the validation information and further transmit the validation information; and a secure system in communication with the second device. According to one embodiment, the secure system includes a database. In a further embodiment, the secure system is configured to receive the validation information transmitted from the second device, and to transmit additional information to the second device following a receipt of the validation information to assist the second device in either enabling or preventing the occurrence of the event.

(58) **Field of Classification Search** ..... **705/76**  
See application file for complete search history.

(56) **References Cited**

**U.S. PATENT DOCUMENTS**

4,720,860 A 1/1988 Weiss  
4,856,062 A 8/1989 Weiss  
4,885,778 A 12/1989 Weiss  
4,998,279 A 3/1991 Weiss  
5,023,908 A 6/1991 Weiss  
5,058,161 A 10/1991 Weiss

**31 Claims, 28 Drawing Sheets**

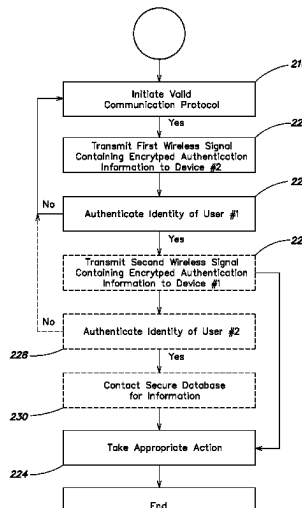
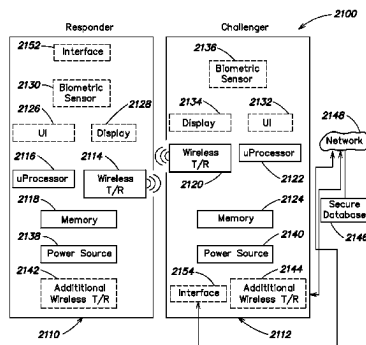

U.S. PATENT DOCUMENTS

5,479,512	A	12/1995	Weiss	
5,485,519	A	1/1996	Weiss	
5,657,388	A	8/1997	Weiss	
5,664,109	A	9/1997	Johnson et al.	
5,813,006	A	9/1998	Polnerow et al.	
5,915,023	A	6/1999	Bernstein	
6,073,106	A	6/2000	Rozen et al.	
6,130,621	A	10/2000	Weiss	
6,253,202	B1	6/2001	Gilmour	
6,253,203	B1	6/2001	O'Flaherty et al.	
6,260,039	B1	7/2001	Schneck et al.	
6,308,203	B1	10/2001	Itabashi et al.	
6,309,342	B1*	10/2001	Blazey et al.	600/26
6,393,421	B1	5/2002	Paglin	
6,516,315	B1	2/2003	Gupta	
6,546,005	B1	4/2003	Berkley et al.	
6,581,059	B1	6/2003	Barrett et al.	
6,640,211	B1	10/2003	Holden	
6,658,400	B2	12/2003	Perell et al.	
6,819,219	B1*	11/2004	Bolle et al.	340/5.52
6,845,448	B1	1/2005	Chaganti et al.	
6,941,271	B1	9/2005	Soong	
7,237,117	B2	6/2007	Weiss	
7,249,112	B2	7/2007	Berardi et al.	
7,278,026	B2	10/2007	McGowan	
7,489,781	B2	2/2009	Klassen et al.	
7,502,459	B1	3/2009	Moseley	
7,548,981	B1*	6/2009	Taylor et al.	709/227
7,571,139	B1	8/2009	Giordano et al.	
7,657,639	B2	2/2010	Hinton	
7,705,732	B2	4/2010	Bishop et al.	
2001/0032100	A1	10/2001	Mahmud et al.	
2001/0044900	A1	11/2001	Uchida	
2002/0046061	A1	4/2002	Wright et al.	
2002/0090930	A1	7/2002	Fujiwara et al.	
2002/0176610	A1*	11/2002	Okazaki et al.	382/118
2002/0178364	A1*	11/2002	Weiss	713/182
2003/0115490	A1	6/2003	Russo et al.	
2003/0123713	A1*	7/2003	Geng	382/118
2003/0129965	A1*	7/2003	Siegel	455/411
2003/0163710	A1*	8/2003	Ortiz et al.	713/186
2003/0226041	A1	12/2003	Palmer et al.	
2004/0017934	A1	1/2004	Kocher	
2004/0034771	A1	2/2004	Edgett et al.	
2004/0059923	A1*	3/2004	ShamRao	713/186
2004/0111625	A1	6/2004	Duffy et al.	
2004/0117215	A1	6/2004	Marchosky	
2004/0117302	A1	6/2004	Weichert et al.	
2004/0133787	A1	7/2004	Doughty	
2004/0151351	A1	8/2004	Ito	
2004/0188519	A1*	9/2004	Cassone	235/382
2004/0236699	A1	11/2004	Beenau et al.	
2005/0001711	A1	1/2005	Doughty et al.	
2005/0039027	A1	2/2005	Shapiro	
2005/0187843	A1	8/2005	Lapsley et al.	

2005/0210270	A1*	9/2005	Rohatgi et al.	713/186
2005/0235148	A1	10/2005	Scheidt et al.	
2005/0238208	A1	10/2005	Sim	
2006/0016884	A1	1/2006	Block et al.	
2006/0104486	A1	5/2006	Le Saint et al.	
2006/0122939	A1*	6/2006	Cohen et al.	705/59
2006/0165060	A1	7/2006	Dua	
2006/0256961	A1	11/2006	Brainard et al.	
2007/0040017	A1*	2/2007	Kozlay	235/380
2007/0079136	A1	4/2007	Vishik et al.	
2007/0124597	A1	5/2007	Bedingfield	
2007/0186105	A1	8/2007	Bailey et al.	
2008/0021997	A1	1/2008	Hinton	
2008/0212848	A1*	9/2008	Doyle	382/115
2008/0275819	A1*	11/2008	Rifai	705/44
2009/0144814	A1*	6/2009	Sacco	726/6
2009/0175507	A1*	7/2009	Schaffner	382/117

FOREIGN PATENT DOCUMENTS

EP	1081632	A1*	7/2001
GB	2 382 006		5/2003
WO	1992007436		4/1992
WO	1996036934		11/1996
WO	2002014985		2/2002

OTHER PUBLICATIONS

"PGP: An Introduction to Cryptography." 2000. All pages.\*  
 International Search Report from corresponding PCT/US2007/070701 mailed Mar. 11, 2008.  
 International Search Report from co-pending PCT Application No. PCT/US2007/004646 mailed Nov. 27, 2007.  
 Kessler, G. "An Overview of Cryptography." 22 Aug. 22, 2002. All pages. Retrived via Wayback Machine on Jan. 19, 2010. <http://www.garykessler.net/library/crypto.html>.  
 Pabrai, U. "Biometrics for PC-User Authentication: A Primer" Feb. 1, 2001. Access Controls & Security Systems. All pages. <[http://www.securitysolutions.com/mag/security\\_biometrics\\_pcuser\\_authentication/index.html](http://www.securitysolutions.com/mag/security_biometrics_pcuser_authentication/index.html)>.  
 "Information Security: Challenges in Using Biometrics" Sep. 9, 2003. All pages. <<http://www.gao.gov/new.items/d031137t.pdf>>.  
 Huntington, G. "101 Things to Know About Single Sign On." 2006. Authentication World. All pages. <<http://www.authenticationworld.com/Single-Sign-On-Authentication/101ThingsToKnowAboutSingleSignOn.pdf>>.  
 "Single Sign on Authentication" Mar. 13, 2007. Authentication World. All pages. Retrieved Jul. 9, 2010 via Wayback Machine. <<http://web.archive.org/web/20070313200434/http://www.authenticationworld.com/Single-Sign-On-Authentication/>>.  
 International Search Report from PCT/US2009/035282 mailed Jul. 10, 2009.  
 Treasury Board of Canada Secretariat, PKI for Beginners Glossary, <http://www.tbs-sct.gc.ca/pki-icp/beginners/glossary-eng.asp>.

\* cited by examiner

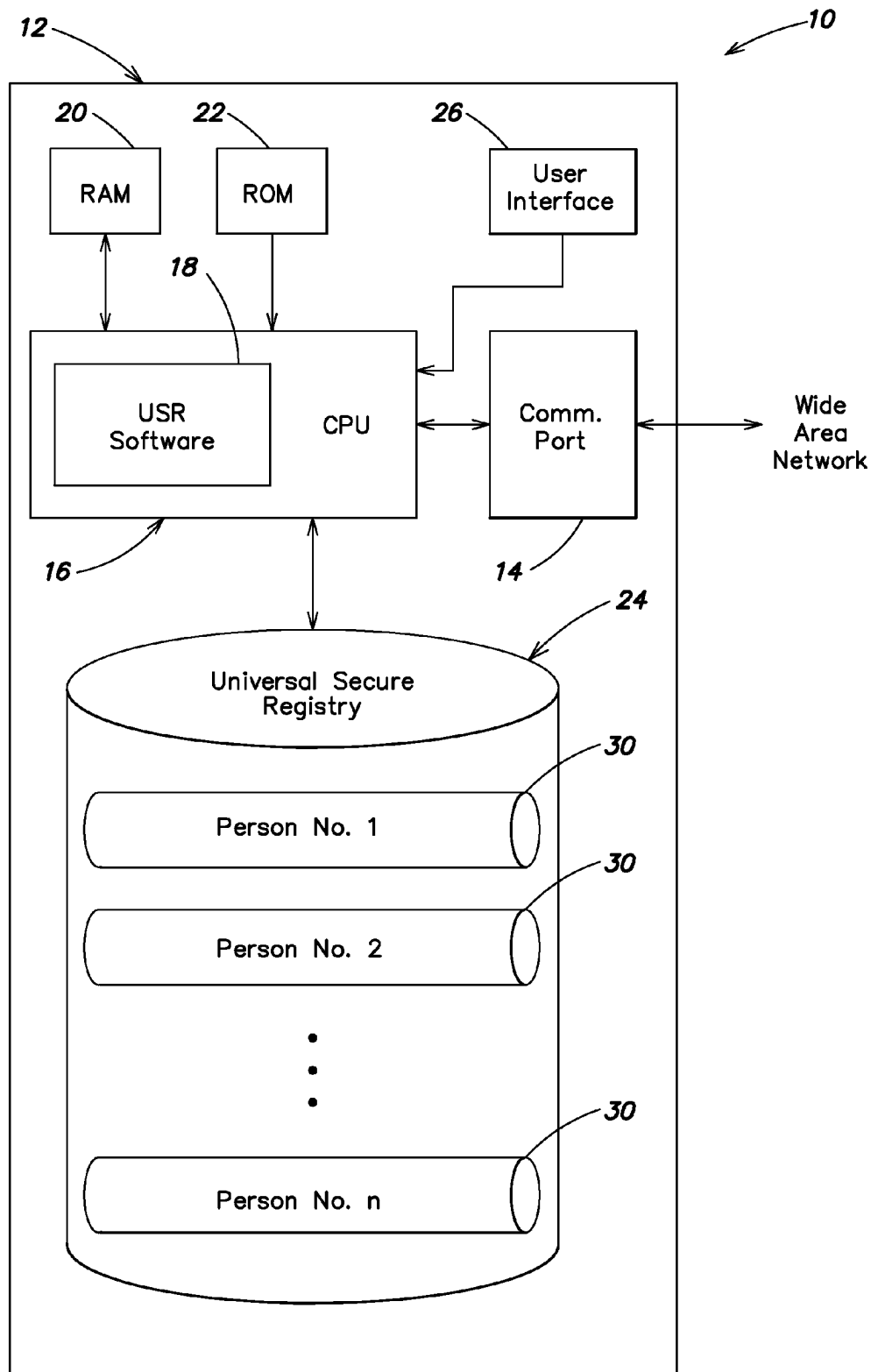

FIG 1

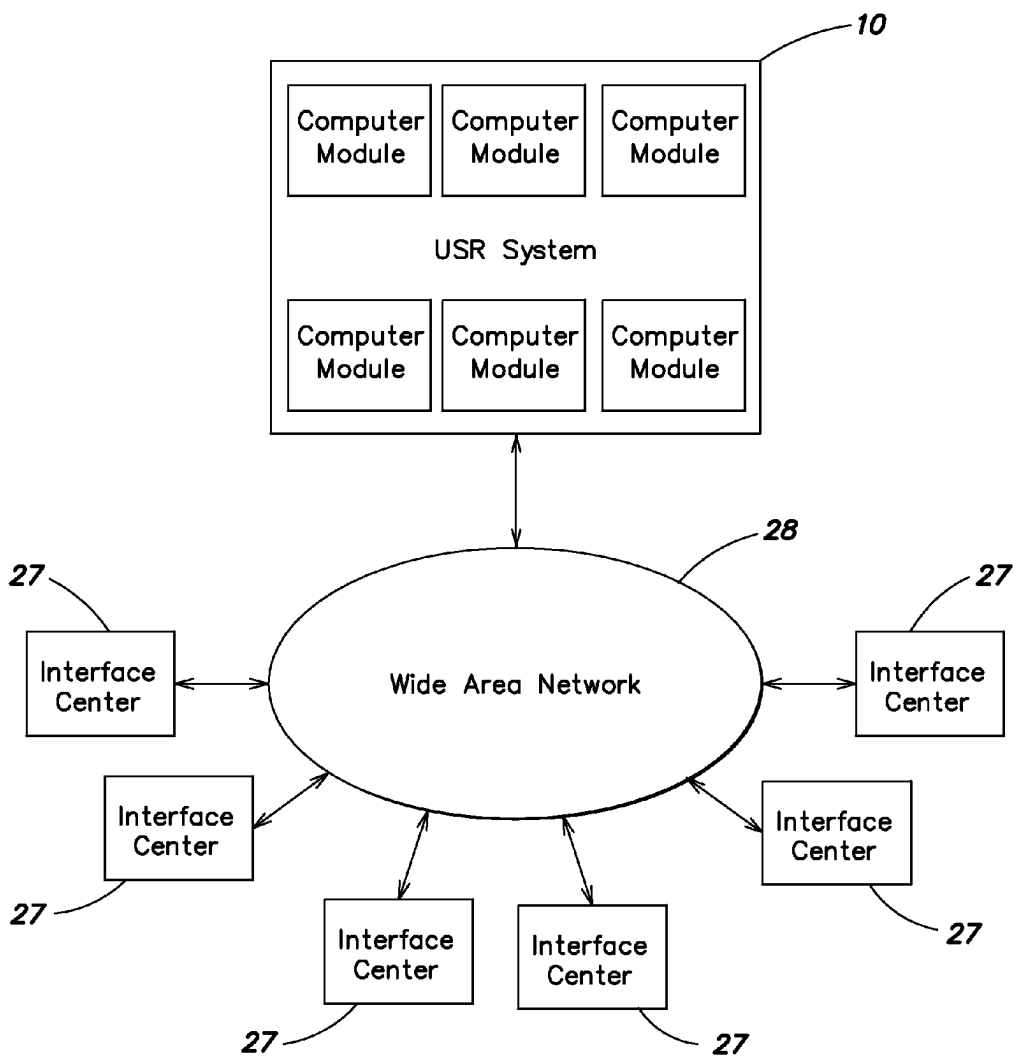

FIG. 2

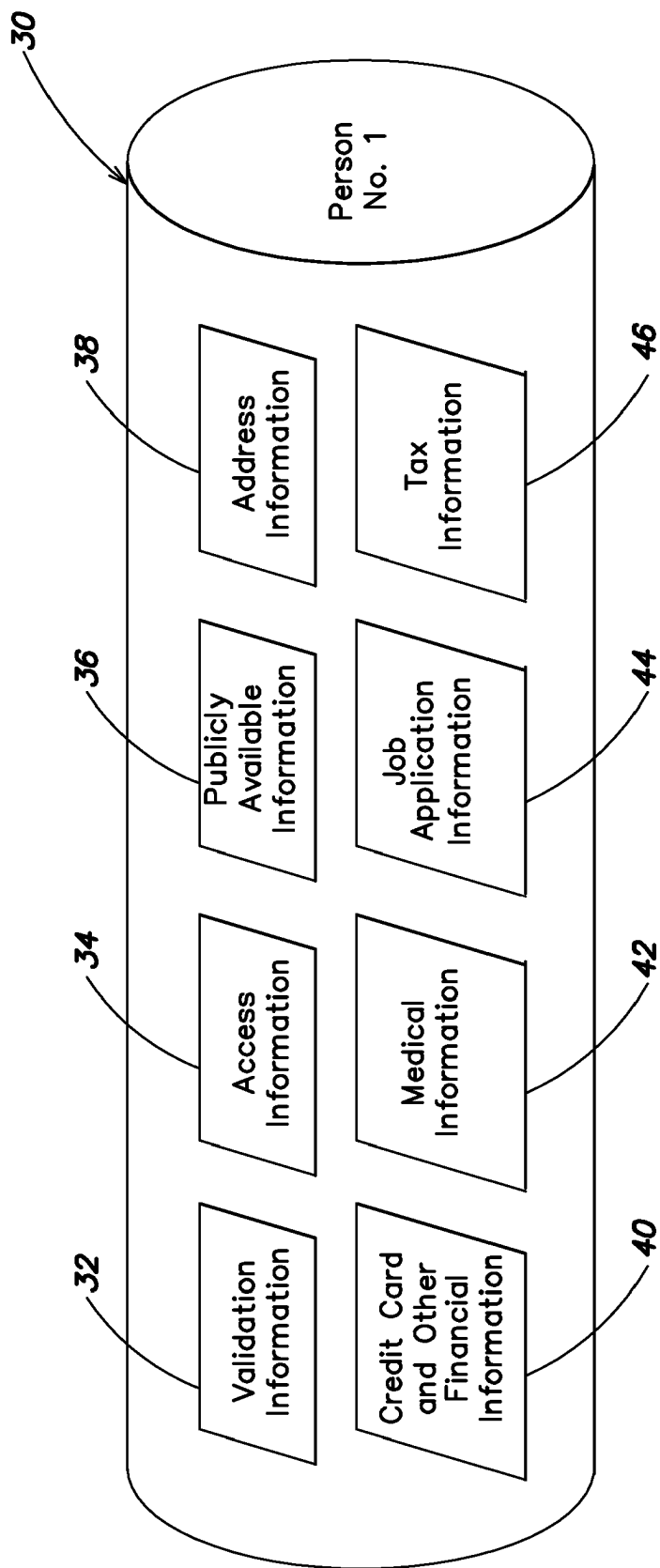

FIG. 3

# Explore Litigation Insights

Docket Alarm provides insights to develop a more informed litigation strategy and the peace of mind of knowing you're on top of things.

## Real-Time Litigation Alerts



Keep your litigation team up-to-date with **real-time alerts** and advanced team management tools built for the enterprise, all while greatly reducing PACER spend.

Our comprehensive service means we can handle Federal, State, and Administrative courts across the country.

## Advanced Docket Research



With over 230 million records, Docket Alarm's cloud-native docket research platform finds what other services can't. Coverage includes Federal, State, plus PTAB, TTAB, ITC and NLRB decisions, all in one place.

Identify arguments that have been successful in the past with full text, pinpoint searching. Link to case law cited within any court document via Fastcase.

## Analytics At Your Fingertips



Learn what happened the last time a particular judge, opposing counsel or company faced cases similar to yours.

Advanced out-of-the-box PTAB and TTAB analytics are always at your fingertips.

## API

Docket Alarm offers a powerful API (application programming interface) to developers that want to integrate case filings into their apps.

## LAW FIRMS

Build custom dashboards for your attorneys and clients with live data direct from the court.

Automate many repetitive legal tasks like conflict checks, document management, and marketing.

## FINANCIAL INSTITUTIONS

Litigation and bankruptcy checks for companies and debtors.

## E-DISCOVERY AND LEGAL VENDORS

Sync your system to PACER to automate legal marketing.